



©2013 Lennox Industries Inc.
Dallas, Texas, USA

**THIS MANUAL MUST BE LEFT WITH THE
HOMEOWNER FOR FUTURE REFERENCE**

General

This XC25 outdoor heat pump is designed for use with HFC-410A refrigerant only.

These instructions are intended as a general guide and do not supersede local codes in any way. Consult authorities having jurisdiction before installation.

IMPORTANT: BEFORE APPLYING ANY POWER (MAIN, SOLAR OR LOW VOLTAGE) TO THE OUTDOOR UNIT, THE FIELD MUST CONFIRM ICOMFORT WI-FI® THERMOSTAT HAS VERSION 2.1 OR HIGHER SOFTWARE. (REFERENCE ICOMFORT WI-FI® THERMOSTAT MANUAL)

THIS UNIT IS A INTEGRAL COMPONENT OF A SYSTEM THAT WILL REQUIRE AN ICOMFORT WI-FI® THERMOSTAT AND ICOMFORT™ -ENABLED AIR HANDLER OR FURNACE.



INSTALLATION INSTRUCTIONS

Dave Lennox *Signature*® Collection XC25 System

AIR CONDITIONERS
507004-01
6/2013
Supersedes 4/2013

TPD Technical
Publications
Litho U.S.A.

PACKING LIST

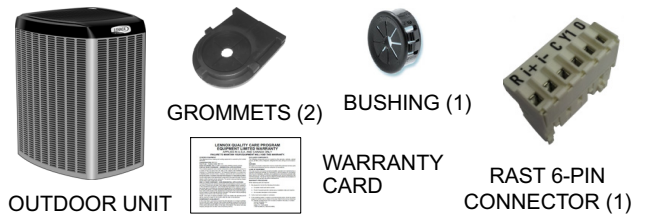

⚠WARNING

Improper installation, adjustment, alteration, service or maintenance can cause property damage, personal injury or loss of life.

Installation and service must be performed by a licensed HVAC professional installer (or equivalent) or service agency.

STEP 1 -- SETTING THE UNIT -- Clearances

CLEARANCE ON ALL SIDES — INCHES (MILLIMETERS)

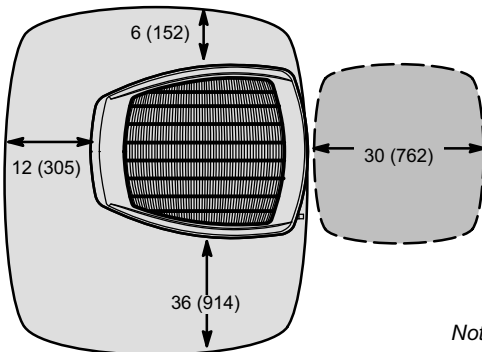

NOTES:

- Clearance to access panel must be 30 inches (762mm).
- Clearance to one of the other three sides must be 36 inches (914mm).
- Clearance to one of the remaining two sides may be 12 inches (305mm) and the final side may be 6 inches (152mm).

Note: Dimensions are not to scale.

MINIMUM CLEARANCE ABOVE UNIT

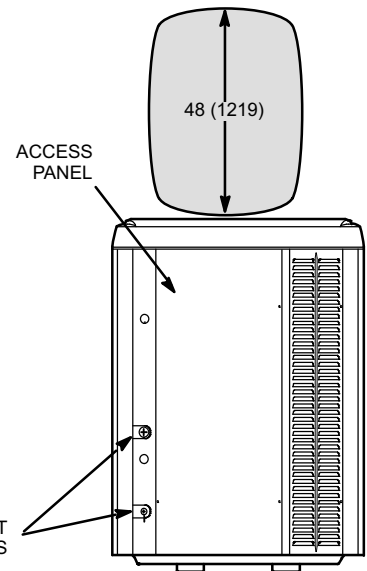

REAR VIEW OF UNIT

MINIMUM CLEARANCE BETWEEN TWO UNITS

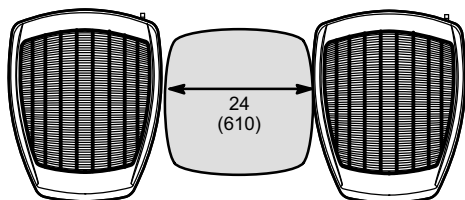
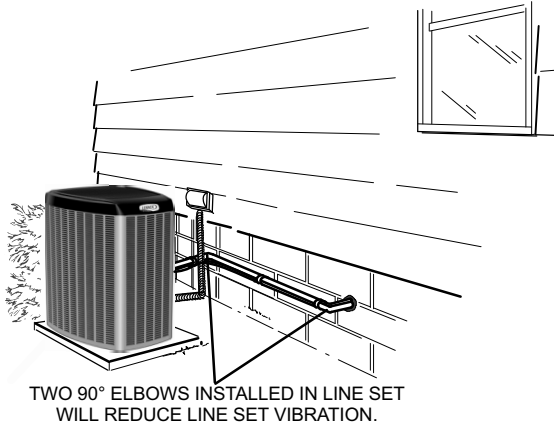

FIGURE 1



DETAIL A

INSTALL UNIT AWAY FROM WINDOWS



Outside Unit Placement

DETAIL B

INSTALL UNIT LEVEL OR, IF ON A SLOPE, MAINTAIN SLOPE TOLERANCE OF 2 DEGREES (OR 2 INCHES PER 5 FEET [50 MM PER 1.5 M]) AWAY FROM BUILDING STRUCTURE.

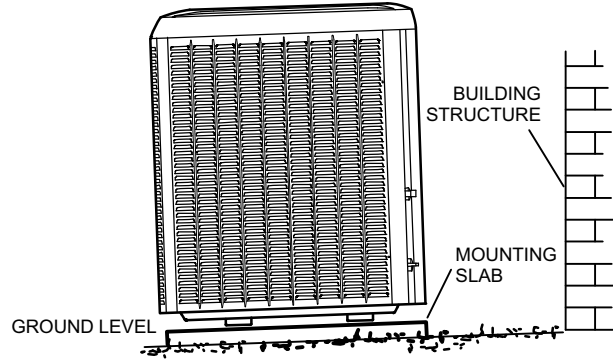

Slab Mounting at Ground Level

DETAIL C

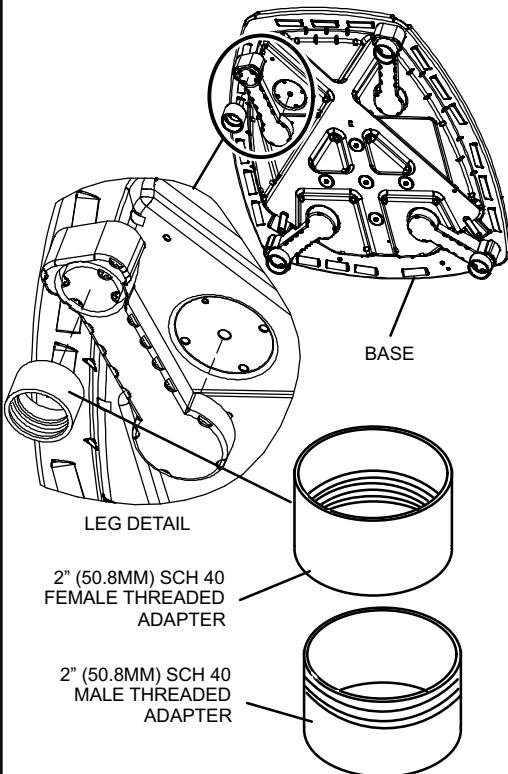

USE ADDITIONAL 2" SCH 40 MALE THREADED ADAPTERS WHICH CAN BE THREADED INTO THE FEMALE THREADED ADAPTERS TO MAKE ADDITIONAL ADJUSTMENTS TO THE LEVEL OF THE UNIT.

Elevated Slab Mounting using Feet Extenders

DETAIL D

Slab Side Mounting

#10 1/2" LONG SELF-DRILLING SHEET METAL SCREWS

STABILIZING BRACKET (18 GAUGE METAL — 2" WIDTH; HEIGHT AS REQUIRED)

#10 1-1/4" LONG HEX HD SCREW AND FLAT WASHER

CONCRETE SLAB — USE TWO PLASTIC ANCHORS (HOLE DRILL 1/4")

WOOD OR PLASTIC SLAB — NO PLASTIC ANCHOR (HOLE DRILL 1/8")

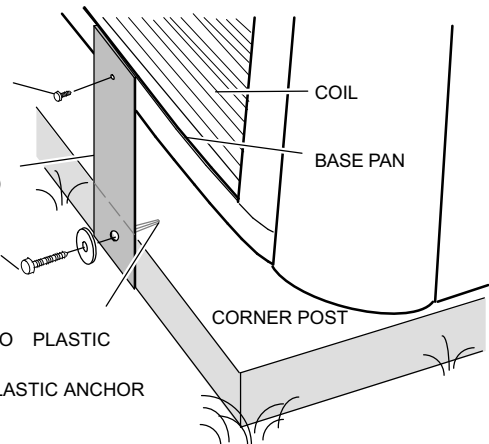

Deck Top Mounting

STABILIZING BRACKET (18 GAUGE METAL — 2" (50.8MM) WIDTH; HEIGHT AS REQUIRED); BEND TO FORM RIGHT ANGLE

SAME FASTENERS AS SLAB SIDE MOUNTING.

MINIMUM ONE PER SIDE

FOR EXTRA STABILITY

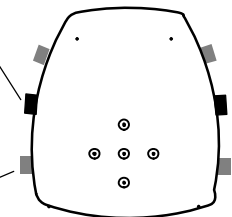
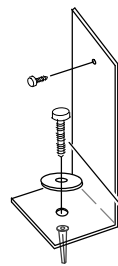

ONE BRACKET PER SIDE (MIN.); FOR EXTRA STABILITY, TWO BRACKETS PER SIDE, 2" (50.8MM) FROM EACH CORNER.

Stabilizing Unit on Uneven Surfaces

IMPORTANT — To help stabilize an outdoor unit, some installations may require strapping the unit to the pad using brackets and anchors commonly available in the marketplace.

NOTICE !

Roof Damage!

This system contains both refrigerant and oil. Some rubber roofing material may absorb oil, causing the rubber to degrade. Failure to follow this notice could result in damage to roof surface.

IMPORTANT !

Exhaust vents from dryers, water heaters and furnaces should be directed away from the outdoor unit. Prolonged exposure to exhaust gases and the chemicals contained within them may cause condensation to form on the steel cabinet and other metal components of the outdoor unit. This will diminish unit performance and longevity.

! WARNING

To prevent personal injury, as well as damage to panels, unit or structure, observe the following:

While installing or servicing this unit, carefully stow all removed panels so that the panels will not cause injury to personnel, objects or nearby structures. Also, take care to store panels where they will not be subject to damage (e.g., being bent or scratched).

While handling or stowing the panels, consider any weather conditions (especially wind) that may cause panels to be blown around and damaged.

UNIT DIMENSIONS - INCHES (MM)

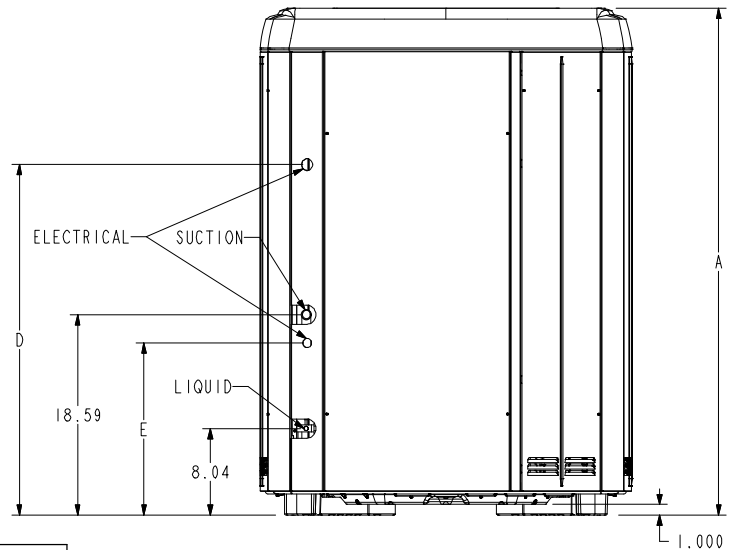
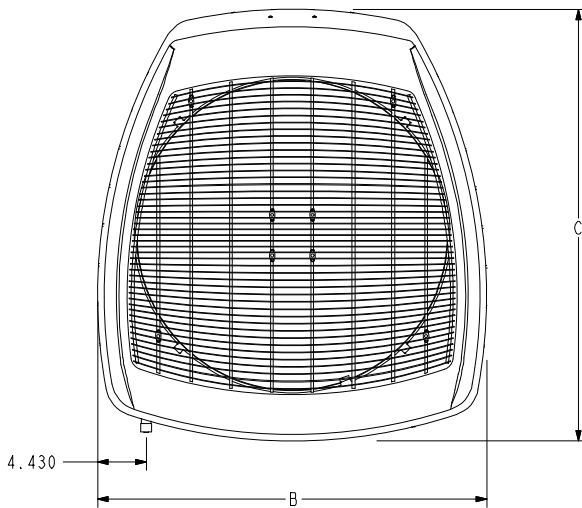

UNIT	DIM A	DIM B	DIM C	DIM D	DIM E
XC25-024	47.00	35.50	39.40	38.88	15.97
XC25-036	47.00	35.50	39.40	38.88	15.97
XC25-048	47.00	35.50	39.40	32.50	15.97
XC25-060	47.00	35.50	39.40	32.50	15.97

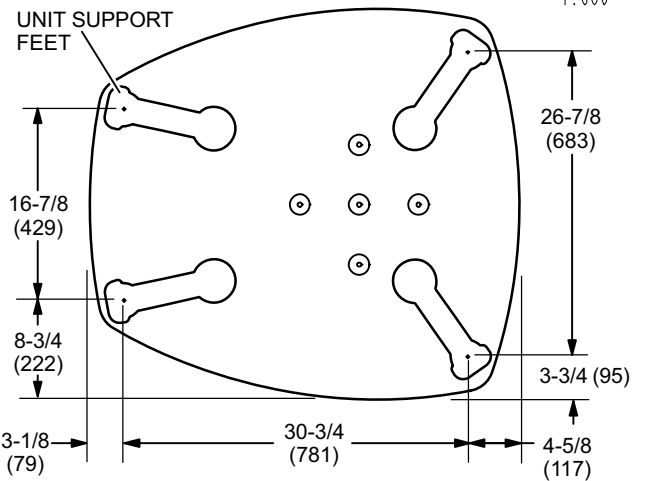

BASE WITH ELONGATED LEGS

! WARNING

The State of California has determined that this product may contain or produce a chemical or chemicals, in very low doses, which may cause serious illness or death. It may also cause cancer, birth defects, or reproductive harm.

! CAUTION

As with any mechanical equipment, contact with sharp sheet metal edges can result in personal injury. Take care while handling this equipment.

STEP 2 -- REFRIGERANT PIPING -- New or Existing Line Set and Indoor Coil

Flush existing line set per industry standards. For more information concerning flushing procedures, refer to the XC25 Installation and Service Procedures available on DaveNet. **CAUTION - DO NOT** attempt to flush and re-use existing line sets or indoor coil when the system contains contaminants (i.e., compressor burn out).

IMPORTANT !

If this unit is being matched with an approved line set or indoor unit coil that was previously charged with mineral oil, or if it is being matched with a coil which was manufactured before January of 1999, the coil and line set must be flushed prior to installation. Take care to empty all existing traps. Polyol ester (POE) oils are used in Lennox units charged with HFC-410A refrigerant. Residual mineral oil can act as an insulator, preventing proper heat transfer. It can also clog the expansion device and reduce system performance and capacity.

Failure to properly flush the system per the XC25 Installation and Service Procedures will void the warranty.

! WARNING

Polyol ester (POE) oils used with HFC-410A refrigerant absorb moisture very quickly. It is very important that the refrigerant system be kept closed as much as possible. **DO NOT** remove line set caps or service valve stub caps until you are ready to make connections.

! WARNING

Refrigerant can be harmful if it is inhaled. Refrigerant must be used and recovered responsibly. Failure to follow this warning may result in personal injury or death.

! WARNING



Fire, Explosion and Personal Safety Hazard. Failure to follow this warning could result in damage, personal injury or death. Never use oxygen to pressurize or purge refrigeration lines. Oxygen, when exposed to a spark or open flame, can cause fire and/or an explosion, that could result in property damage, personal injury or death.

! WARNING



When using a high pressure gas such as nitrogen to pressurize a refrigeration or air conditioning system, use a regulator that can control the pressure down to 1 or 2 psig (6.9 to 13.8 kPa).

IMPORTANT !

Some scroll compressors have an internal vacuum protector that will unload scrolls when suction pressure goes below 20 psig. A hissing sound will be heard when the compressor is running unloaded. Protector will reset when low pressure in system is raised above 40 psig. **DO NOT REPLACE COMPRESSOR.**

IMPORTANT !

If unit is equipped with a crankcase heater, and outdoor ambient temperature is below 60°F, unit should be energized 24 hours before start-up to prevent compressor damage as a result of slugging.

The XC25 is a variable capacity cooling and heat pump system utilizing variable speed compressor technology. With the variable speed compressor and variable pumping capacity, additional consideration must be given to refrigerant piping sizing and application. The guidelines below are to be used exclusively for the XC25 systems.

COOLING SYSTEM (HFC-410A)

- Total equivalent length equals 180 feet (piping and all fittings included).

NOTE — Length is general guide. Lengths may be more or less, depending on remaining system design factors.

- Maximum linear (actual) length = 150 feet.
- Maximum linear liquid lift = 60 feet.

NOTE — Maximum lifts are dependent on total length, number of elbows, etc. that contribute to total pressure drop.

- Maximum length vapor riser equals 60 feet.
- **Up to 50 Linear Feet:** Use rated line sizes listed in table 1.
- **Between 51 - 150 Linear Feet:** Crankcase heater and non-bleed port TXV factory installed. No additional components required. Vertical vapor riser must be sized to the vapor riser listed in the table 2 on systems with line sets longer than 51 feet. Use tables 2 and 3 to determine the correct liquid and vapor line sizes.
- **Over 150 Linear Feet:** not recommended.
- Additional oil is not required for systems with line lengths up to 150 feet.

SUCTION TRAPS

For systems with the outdoor unit 5 - 60 feet above the indoor unit, one trap must be installed at the bottom of the suction riser.

ADDING REFRIGERANT FOR LONG LINE SETS

WEIGH IN

CHARGING METHOD FOR LONG LINE SETS

64°F (17.7°C) and Below

Amount specified on nameplate \pm Adjust amount, for variation in line set length and liquid line diameter using table below. = Total charge



Liquid Line Set Diameter	HFC-410A (ounces per foot)
5/16"	0.40
3/8"	0.60
1/2"	1.00

NOTE — Insulate liquid line when it is routed through areas where the surrounding ambient temperature could become higher than the temperature of the liquid line or when pressure drop is equal to or greater than 20 psig.

NOTE — The above nameplate is for illustration purposes only. Go to actual nameplate on outdoor unit for charge information.

Charging Formula for Liquid Line Charge Adjustments

[(Line set oz./ft. x total length) - (factory charge for line set)] = charge adjustment

Example: Units are factory-charged for 15 feet (4.6 meters) of 3/8" line set. Factory charge for 3/8" is 0.60 oz/ft x 15 = 9.0 ounces.

Figure 2. Using HFC-410A Weigh In Method

Table 1. Standard Refrigerant Line Set — Up to 50 Linear Feet

Inches (mm)					
Model Number (-xx*)	Valve Size Connections		Recommended Line Sets		
Model Number (-xx*)	Liquid Line	Suction Line	L15 Line Set Model	Line Set Length	Catalog Number
XC25-024-230-XX XC25-036-230-XX XC25-048-230-XX	3/8" (10 mm)	7/8" (22 mm)	L15-65-30	30 feet (9.1 m)	89J60
			L15-65-40	40 feet (12.2 m)	89J61
			L15-65-50	50 feet (15.2 m)	89J62
XC25-060-230-XX	3/8" (10 mm)	1-1/8" (29 mm) **	Field-fabricated		

* Applicable to all minor revision numbers unless otherwise specified.
** Some applications may require a field-provided 1-1/8" to 7/8" adapter.

Table 2. XC25 Line Set Guidelines Between — 51 - 150 Linear Length

Model	Maximum Total Equivalent Length (ft)	Maximum Linear (actual) Length (ft)	Maximum Vapor Riser (ft)	Maximum Linear Liquid Lift (ft)	Preferred Vapor Line Sizes for Horizontal Runs	Required Vapor Riser Size
-024	180	150	60	60	7/8"	5/8"
-036	180	150	60	60	7/8"	3/4"
-048	180	150	60	60	7/8"	7/8"
-060	180	150	60	60	7/8"	7/8"

Table 3. Liquid Line Diameter Selection Table

Unit	Line Size	Total Linear Length (feet)						Max. Elevation (ft)
		25	50	75	100	125	150	
-024	5/16"	25	50	55	48	40	33	
	3/8"	25	50	60	60	60	60	
-036	3/8"	25	50	60	56	51	45	
	1/2"	25	50	60	60	60	60	
-048	3/8"	25	50	50	41	31	22	
	1/2"	25	50	60	60	60	60	
-060	3/8"	25	50	36	22	8	NR	
	1/2"	25	50	60	60	60	59	

Note - Shaded rows indicate rated liquid line size

- Find your unit on the left side of the table.
- Start with the rated liquid line size (shaded row) on the outdoor unit
- Select the actual Total Linear Length of your system shown at the top of the table.
- The elevation listed in the table is the maximum allowed for the liquid line listed.
- Select or consider the larger liquid line size shown in the table if the elevation does not meet your requirements.

NOTE - For new or replacement line set installation, refer to Service and Application Note - Corp. 9112-L4 (C-91-4).

STEP 2 -- REFRIGERANT PIPING -- Removing Existing Indoor Metering Device

1A TYPICAL EXISTING FIXED ORIFICE REMOVAL PROCEDURE (UNCASED COIL SHOWN)

OR 1B TYPICAL EXISTING EXPANSION VALVE REMOVAL PROCEDURE (UNCASED COIL SHOWN)

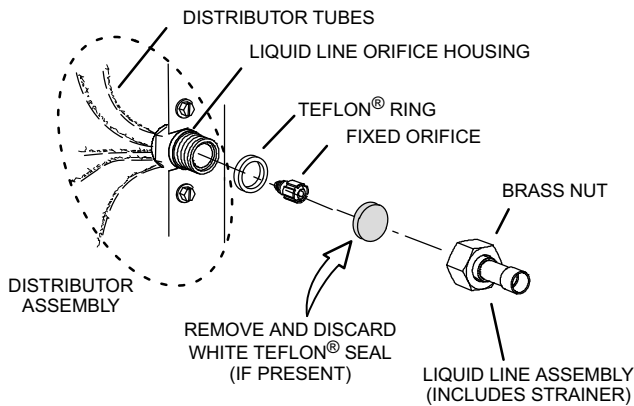

6. On fully cased coils, remove the coil access and plumbing panels.
7. Remove any shipping clamps from the liquid line and distributor assembly.
8. Using two wrenches, disconnect liquid line from liquid line orifice housing. Take care not to twist or damage distributor tubes during this process.
9. Remove and discard fixed orifice, valve stem assembly (if present) and Teflon® washer as illustrated above.
10. Use a field-provided fitting to temporarily reconnect the liquid line to the indoor unit's liquid line orifice housing.

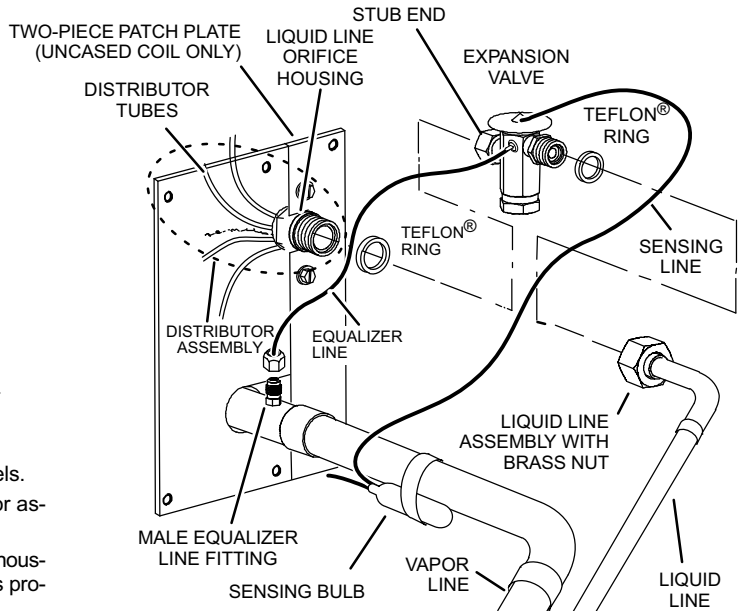

1. On fully cased coils, remove the coil access and plumbing panels.
2. Remove any shipping clamps from the liquid line and distributor assembly.
3. Disconnect the equalizer line from the check expansion valve equalizer line fitting on the vapor line.
4. Remove the vapor line sensing bulb.
5. Disconnect the liquid line from the check expansion valve at the liquid line assembly.
6. Disconnect the check expansion valve from the liquid line orifice housing. Take care not to twist or damage distributor tubes during this process.
7. Remove and discard check expansion valve and the two Teflon® rings.
8. Use a field-provided fitting to temporarily reconnect the liquid line to the indoor unit's liquid line orifice housing.

2 CONNECT GAUGES AND EQUIPMENT FOR FLUSHING PROCEDURE

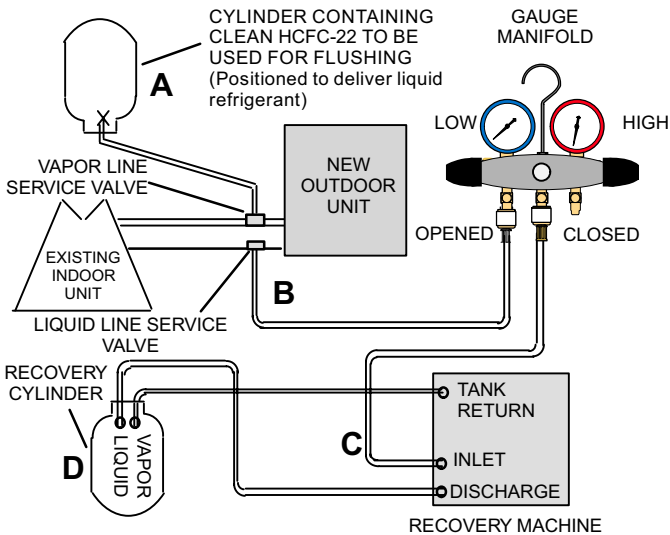

1. HCFC-22 cylinder with clean refrigerant (positioned to deliver liquid refrigerant) to the vapor service valve.
2. HCFC-22 gauge set (low side) to the liquid line valve.
3. HCFC-22 gauge set center port to inlet on the recovery machine with an empty recovery tank connected to the gauge set.
4. Connect recovery tank to recovery machine per machine instructions.

3 FLUSHING LINE SET

The line set and indoor unit coil must be flushed with at least the same amount of clean refrigerant that previously charged the system. Check the charge in the flushing cylinder before proceeding.

1. Set the recovery machine for liquid recovery and start the recovery machine. Open the gauge set valves to allow the recovery machine to pull a vacuum on the existing system line set and indoor unit coil.
2. Position the cylinder of clean HCFC-22 for delivery of liquid refrigerant and open its valve to allow liquid refrigerant to flow into the system through the vapor line valve. Allow the refrigerant to pass from the cylinder and through the line set and the indoor unit coil before it enters the recovery machine.
3. After all of the liquid refrigerant has been recovered, switch the recovery machine to vapor recovery so that all of the HCFC-22 vapor is recovered. Allow the recovery machine to pull the system down to 0.
4. Close the valve on the inverted HCFC-22 drum and the gauge set valves. Pump the remaining refrigerant out of the recovery machine and turn the machine off.

FIGURE 3

STEP 2 -- REFRIGERANT PIPING -- Brazing Procedures

1 PIPING PANEL REMOVAL / PREPARING LINE SET

Remove piping panel to access service valves. Cut ends of the refrigerant lines square (free from nicks or dents) and debur the ends. The pipe must remain round. Do not crimp end of the line.

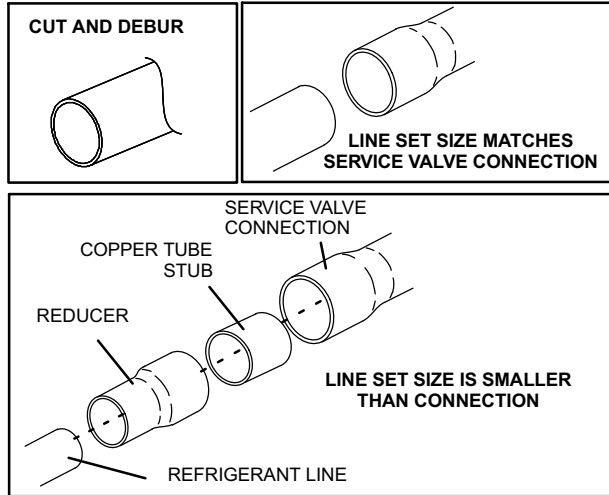

DO NOT CRIMP SERVICE VALVE CONNECTOR WHEN PIPE IS SMALLER THAN CONNECTION

2 CAP AND CORE REMOVAL

Remove service cap and core from both the suction / vapor and liquid line service ports.

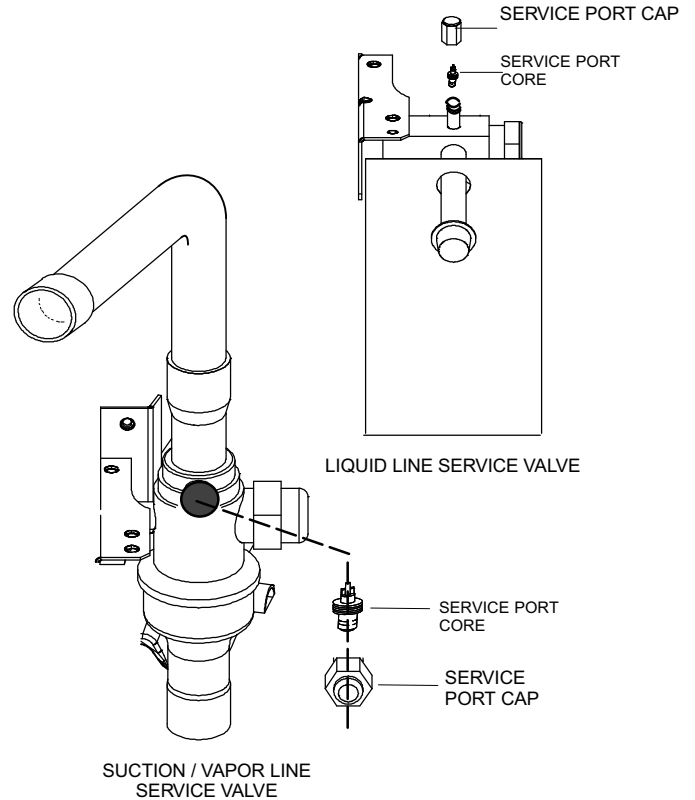

3 ATTACH THE MANIFOLD GAUGE SET FOR BRAZING LIQUID AND SUCTION / VAPOR LINE SERVICE VALVES

- Connect gauge set low pressure side to liquid line service valve (service port).
- Connect gauge set center port to bottle of nitrogen with regulator.
- With valve core removed from the suction / vapor line service port, nitrogen flow will have an exit point.

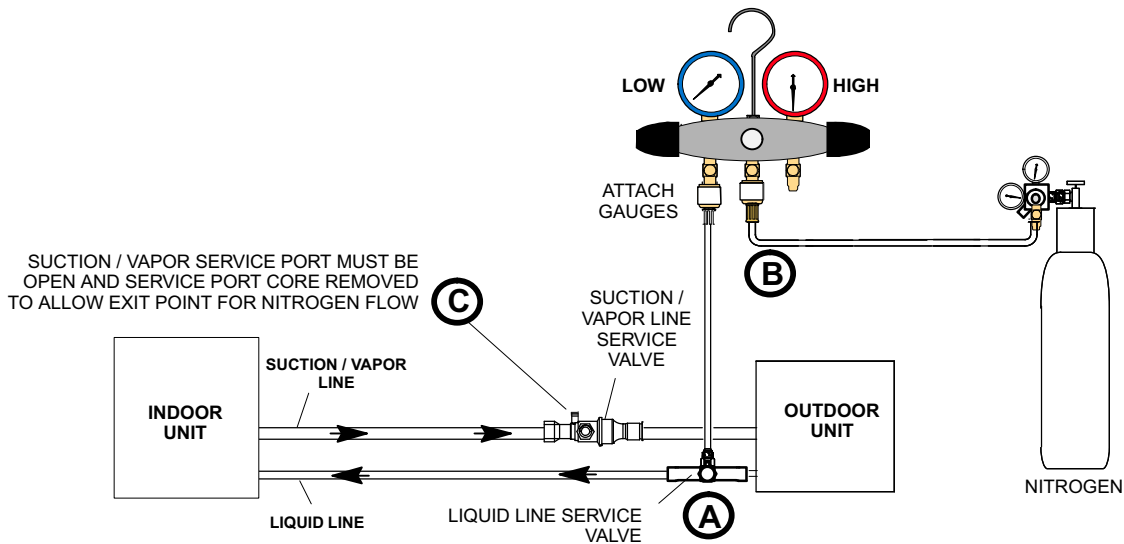

FIGURE 4

⚠ CAUTION

Brazing alloys and flux contain materials which are hazardous to your health.

Avoid breathing vapors or fumes from brazing operations. Perform operations only in well-ventilated areas.

Wear gloves and protective goggles or face shield to protect against burns.

Wash hands with soap and water after handling brazing alloys and flux.

⚠ WARNING



Danger of fire. Bleeding the refrigerant charge from only the high side may result in pressurization of the low side shell and suction tubing. Application of a brazing torch to a pressurized system may result in ignition of the refrigerant and oil mixture. Check the high and low pressures before applying heat.

4 WRAP SERVICE VALVES

To help protect service valve seals during brazing, wrap water-saturated cloths around service valve bodies and copper tube stubs. Use additional water-saturated cloths under the valve body to protect the base paint.

5 FLOW NITROGEN

Flow regulated nitrogen (at 1 to 2 psig) through the refrigeration gauge set into the valve stem port connection on the liquid service valve and out of the suction / vapor valve stem port. See steps 3A, 3B and 3C on previous page and below for manifold gauge setup.

6 BRAZE LINE SET

Cloths must remain water-saturated throughout the brazing and cool-down process.

1. Braze liquid line to liquid line service valve.
2. Braze suction / vapor line to suction / vapor service valve.

IMPORTANT !

Use silver alloy brazing rods with 5% minimum silver alloy for copper-to-copper brazing and 45% alloy for copper-to-brass or copper-to-steel brazing.

IMPORTANT !

Allow braze joint to cool. Apply additional water-saturated cloths to help cool brazed joints. Do not remove water-saturated cloths until piping has cooled. Temperatures above 250°F will damage valve seals.

WARNING

FIRE, PERSONAL INJURY, OR PROPERTY DAMAGE may result if you do not wrap a water-saturated cloth around both liquid and suction line service valve bodies and copper tube stub while brazing the line set! The braze, when complete, must be quenched with water to absorb any residual heat.

Do not open service valves until refrigerant lines and indoor coil have been leak-tested and evacuated. Refer to Installation and Service Procedures manual found on DAVENET.

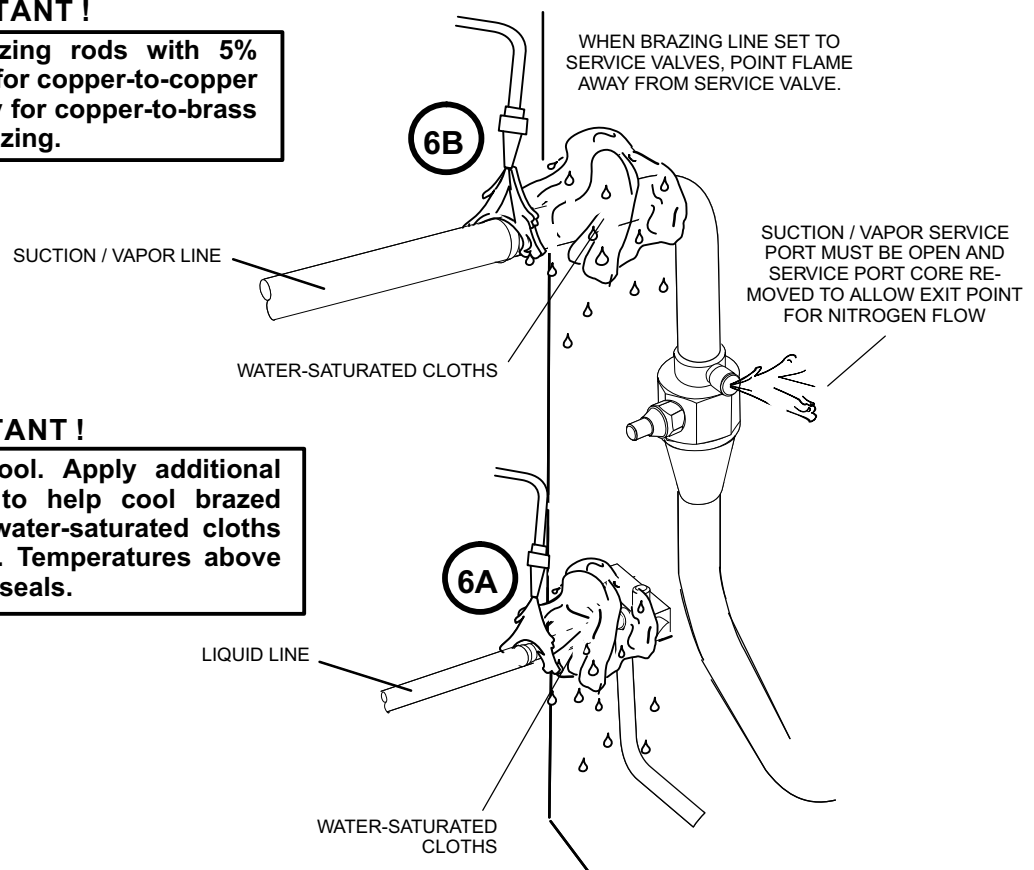

7 PREPARATION FOR NEXT STEP

After all connections have been brazed, disconnect manifold gauge set from service ports. Apply additional water-saturated cloths to both services valves to cool piping. Once piping is cool, remove all water-saturated cloths.

FIGURE 5

STEP 3 -- INSTALLING INDOOR EXPANSION VALVE

This outdoor unit is designed for use in systems that include an expansion valve metering device. See the *XC25 Product Specifications bulletin (EHB)* for approved expansion valve kit match-ups and application information. The expansion valve can be installed internal or external to the indoor coil. In applications where an uncased coil is being installed in a field-provided plenum, install the expansion valve in a manner that will provide access for future field service of the expansion valve. Refer to below illustration for reference during installation of expansion valve.

INDOOR EXPANSION VALVE INSTALLATION

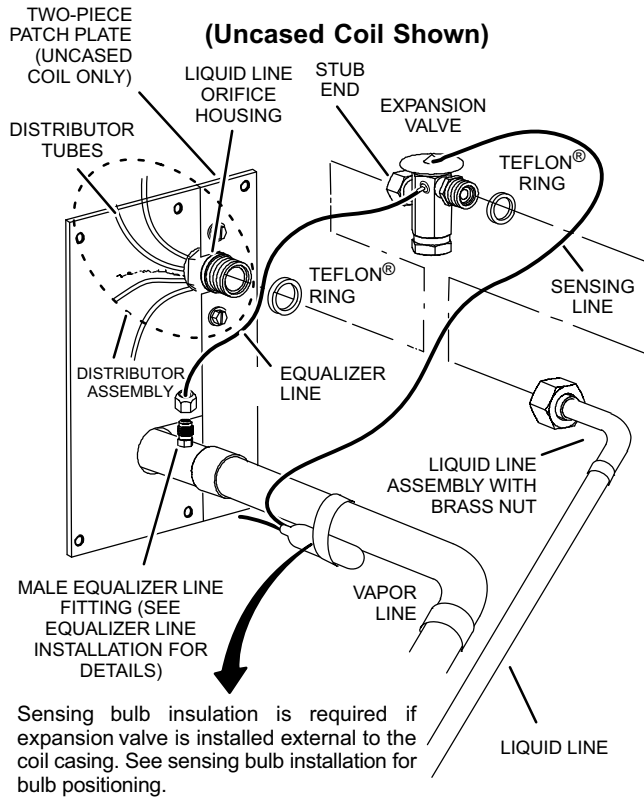

3. Install one of the provided Teflon® rings around the stubbed end of the expansion valve and use refrigerant oil to lightly lubricate the connector threads and exposed surface of the Teflon® ring.
4. Attach the stubbed end of the expansion valve to the liquid line orifice housing. Finger tighten, then use an appropriately sized wrench to turn an additional 1/2 turn clockwise as illustrated in the figure to the right, or tighten to 20 ft-lb.
5. Place the remaining Teflon® washer around the other end of the expansion valve. Lightly lubricate connector threads and expose surface of the Teflon® ring with refrigerant oil.
6. Attach the liquid line assembly to the expansion valve. Finger tighten, then use an appropriately sized wrench to turn an additional 1/2 turn clockwise as illustrated in the figure above or tighten to 20 ft-lb.

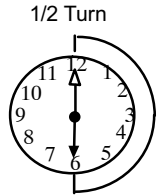

SENSING BULB INSTALLATION

1. Attach the vapor line sensing bulb in the proper orientation as illustrated below using the clamp and screws provided.
2. **NOTE** - Though it is preferred to have the sensing bulb installed on a horizontal run of the vapor line, installation on a vertical run of piping is acceptable if necessary.

NOTE — Confirm proper thermal contact between vapor line and expansion bulb before insulating the sensing bulb.

3. Connect the equalizer line from the expansion valve to the equalizer vapor port on the vapor line. Finger tighten the flare nut, then tighten an additional 1/8 turn (7 ft-lbs) as illustrated to the right.

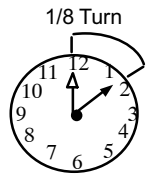

EQUALIZER LINE INSTALLATION

1. Remove and discard either the flare seal cap or flare nut with copper flare seal bonnet from the equalizer line port on the vapor line as illustrated in the figure below.
2. Remove the field-provided fitting that temporarily reconnected the liquid line to the indoor unit's distributor assembly.

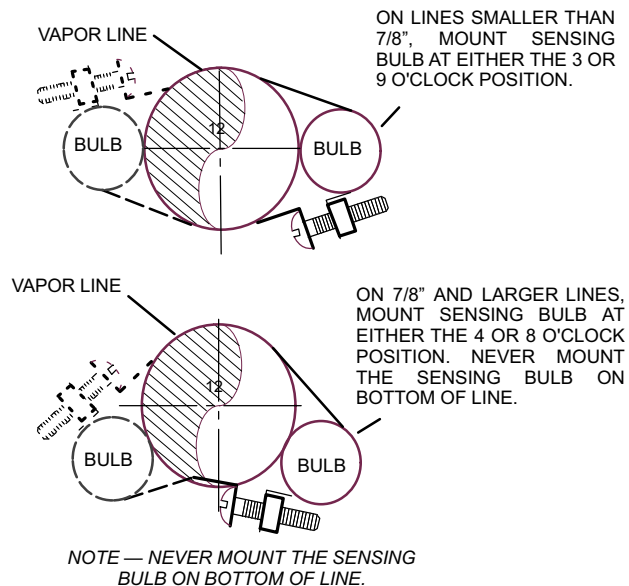
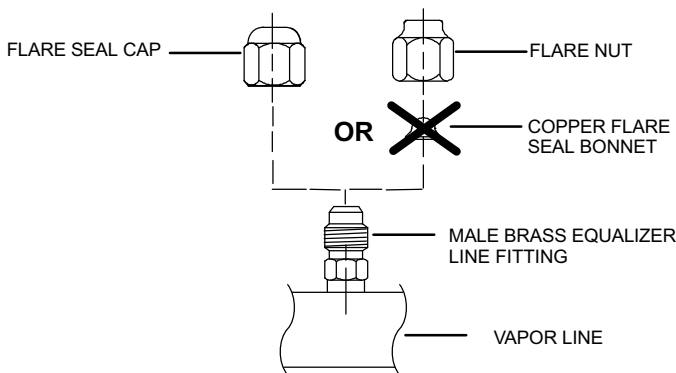
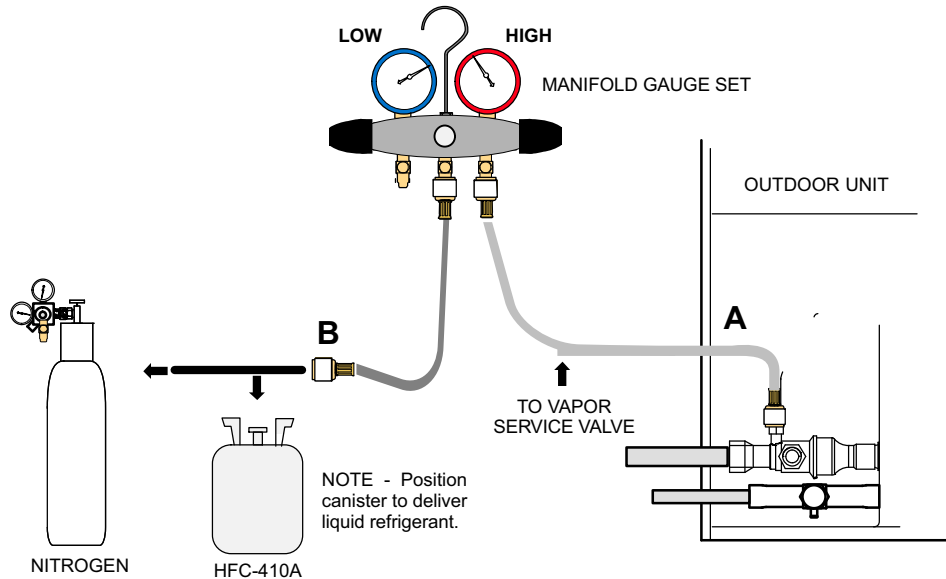

FIGURE 6

STEP 4 -- LEAK TEST AND EVACUATION



1 CONNECT GAUGE SET

- A. Connect the high pressure hose of an HFC-410A manifold gauge set to the vapor valve service port.

NOTE — Normally, the high pressure hose is connected to the liquid line port. However, connecting it to the vapor port better protects the manifold gauge set from high pressure damage.

- B. With both manifold valves closed, connect the cylinder of HFC-410A refrigerant to the center port of the manifold gauge set.

NOTE — Later in the procedure, the HFC-410A container will be replaced by the nitrogen container.

2 TEST FOR LEAKS

After the line set has been connected to the indoor and outdoor units, check the line set connections and indoor unit for leaks. Use the following procedure to test for leaks:

- A. With both manifold valves closed, connect the cylinder of HFC-410A refrigerant to the center port of the manifold gauge set. Open the valve on the HFC-410A cylinder (vapor only).
- B. Open the high pressure side of the manifold to allow HFC-410A into the line set and indoor unit. Weigh in a trace amount of HFC-410A. [A trace amount is a maximum of two ounces (57 g) refrigerant or three pounds (31 kPa) pressure.] Close the valve on the HFC-410A cylinder and the valve on the high pressure side of the manifold gauge set. Disconnect the HFC-410A cylinder.
- C. Connect a cylinder of nitrogen with a pressure regulating valve to the center port of the manifold gauge set.
- D. Adjust nitrogen pressure to 150 psig (1034 kPa). Open the valve on the high side of the manifold gauge set in order to pressurize the line set and the indoor unit.
- E. After a few minutes, open one of the service valve ports and verify that the refrigerant added to the system earlier is measurable with a leak detector.
- F. After leak testing, disconnect gauges from service ports.

FIGURE 7

STEP 4 -- LEAK TEST AND EVACUATION (Continued)

3 EVACUATION

CONNECT GAUGE SET

NOTE — Remove cores from service valves (if not already done).

- Connect low side of manifold gauge set with 1/4 SAE in-line tee to *vapor* line service valve
- Connect high side of manifold gauge set to *liquid* line service valve
- Connect available micron gauge connector on the 1/4 SAE in-line tee.
- Connect the vacuum pump (with vacuum gauge) to the center port of the manifold gauge set. The center port line will be used later for both the HFC-410A and nitrogen containers.

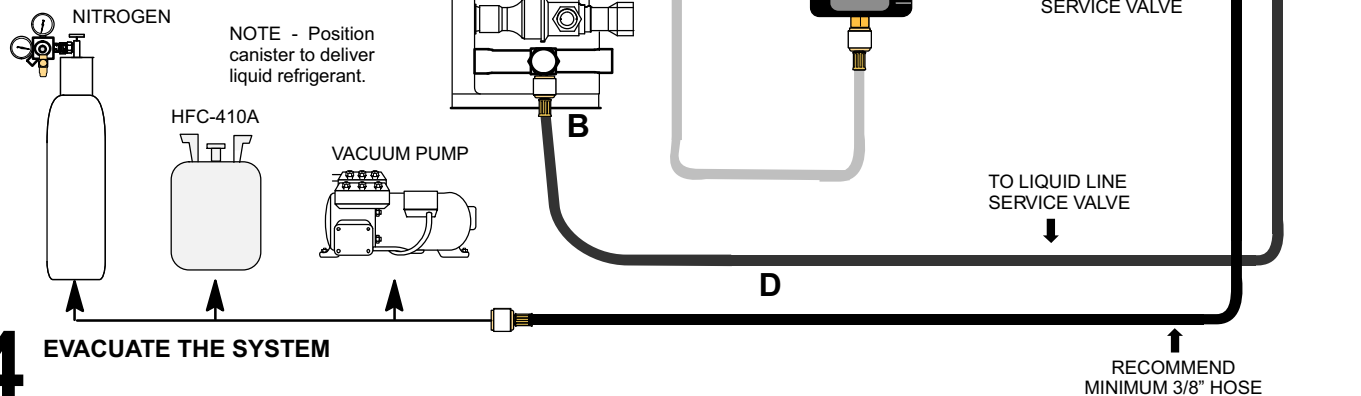

4

EVACUATE THE SYSTEM

- Open both manifold valves and start the vacuum pump.
- Evacuate the line set and indoor unit to an **absolute pressure** of 23,000 microns (29.01 inches of mercury).

NOTE — During the early stages of evacuation, it is desirable to close the manifold gauge valve at least once. A rapid rise in pressure indicates a relatively large leak. If this occurs, **repeat the leak testing procedure**.

NOTE — The term **absolute pressure** means the total actual pressure above zero within a given volume or system. Absolute pressure in a vacuum is equal to atmospheric pressure minus vacuum pressure.
- When the absolute pressure reaches 23,000 microns (29.01 inches of mercury), perform the following:
 - Close manifold gauge valves.
 - Close valve on vacuum pump.
 - Turn off vacuum pump.
 - Disconnect manifold gauge center port hose from vacuum pump.
 - Attach manifold center port hose to a nitrogen cylinder with pressure regulator set to 150 psig (1034 kPa) and purge the hose.
 - Open manifold gauge valves to break the vacuum in the line set and indoor unit.
 - Close manifold gauge valves.
- Shut off the nitrogen cylinder and remove the manifold gauge hose from the cylinder. Open the manifold gauge valves to release the nitrogen from the line set and indoor unit.
- Reconnect the manifold gauge to the vacuum pump, turn the pump on, and continue to evacuate the line set and indoor unit until the absolute pressure does not rise above 500 microns (29.9 inches of mercury) within a 20-minute period after shutting off the vacuum pump and closing the manifold gauge valves.
- When the absolute pressure requirement above has been met, disconnect the manifold hose from the vacuum pump and connect it to a cylinder of HFC-410A positioned to deliver liquid refrigerant. Open the manifold gauge valve 1 to 2 psig in order to release the vacuum in the line set and indoor unit.
- Perform the following:
 - Close manifold gauge valves.
 - Shut off HFC-410A cylinder.
 - Reinstall service valve cores by removing manifold hose from service valve. Quickly install cores with core tool while maintaining a positive system pressure.
 - Replace stem caps and finger tighten them, then tighten an additional one-sixth (1/6) of a turn as illustrated.

WARNING !

Possible equipment damage.

Avoid deep vacuum operation. Do not use compressors to evacuate a system. Extremely low vacuum can cause internal arcing and compressor failure. Damage caused by deep vacuum operation will void warranty.

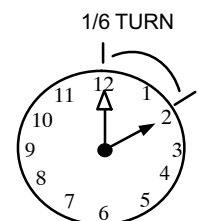

FIGURE 8

STEP 5 -- ELECTRICAL -- Circuit Sizing and Wire Routing

In the U.S.A., wiring must conform with current local codes and the current National Electric Code (NEC). In Canada, wiring must conform with current local codes and the current Canadian Electrical Code (CEC).

Refer to the furnace or air handler installation instructions for additional wiring application diagrams and refer to unit nameplate for minimum circuit ampacity and maximum overcurrent protection size.

24VAC TRANSFORMER

Use the transformer provided with the furnace or air handler for low-voltage control power (24VAC - 40 VA minimum)

⚠ WARNING



Electrical Hazard
High Voltage
Wait 5 Minutes
Electrical components may hold charge.
Do not remove this panel or service this area for 5 minutes after the power has been removed.

⚠ CAUTION

ELECTROSTATIC DISCHARGE (ESD)
Precautions and Procedures

Electrostatic discharge can affect electronic components. Take care during unit installation and service to protect the unit's electronic controls. Precautions will help to avoid control exposure to electrostatic discharge by putting the unit, the control and the technician at the same electrostatic potential. Touch hand and all tools on an unpainted unit surface before performing any service procedure to neutralize electrostatic charge.

1 SIZE CIRCUIT AND INSTALL DISCONNECT SWITCH

Refer to the unit nameplate for minimum circuit ampacity, and maximum fuse or circuit breaker size (HACR per NEC). Install power wiring and properly sized disconnect switch.

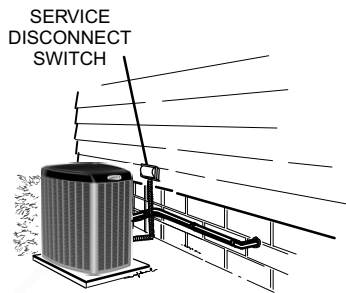

NOTE — Units are approved for use only with copper conductors. Ground unit at disconnect switch or connect to an earth ground.

2 INSTALL THERMOSTAT

Install room thermostat (ordered separately) on an inside wall in the center of the conditioned area and 5 feet (1.5m) from the floor. The thermostat should not be installed on an outside wall or where it can be affected by sunlight or drafts.

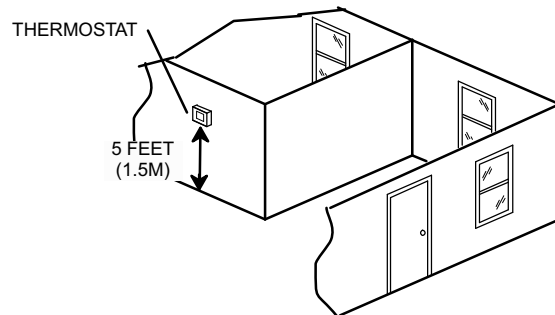

NOTE — 24VAC, Class II circuit connections are made in the control box.

FIGURE 9

3 -- ELECTRICAL (Continued) -- Master Control Jumper and Terminals

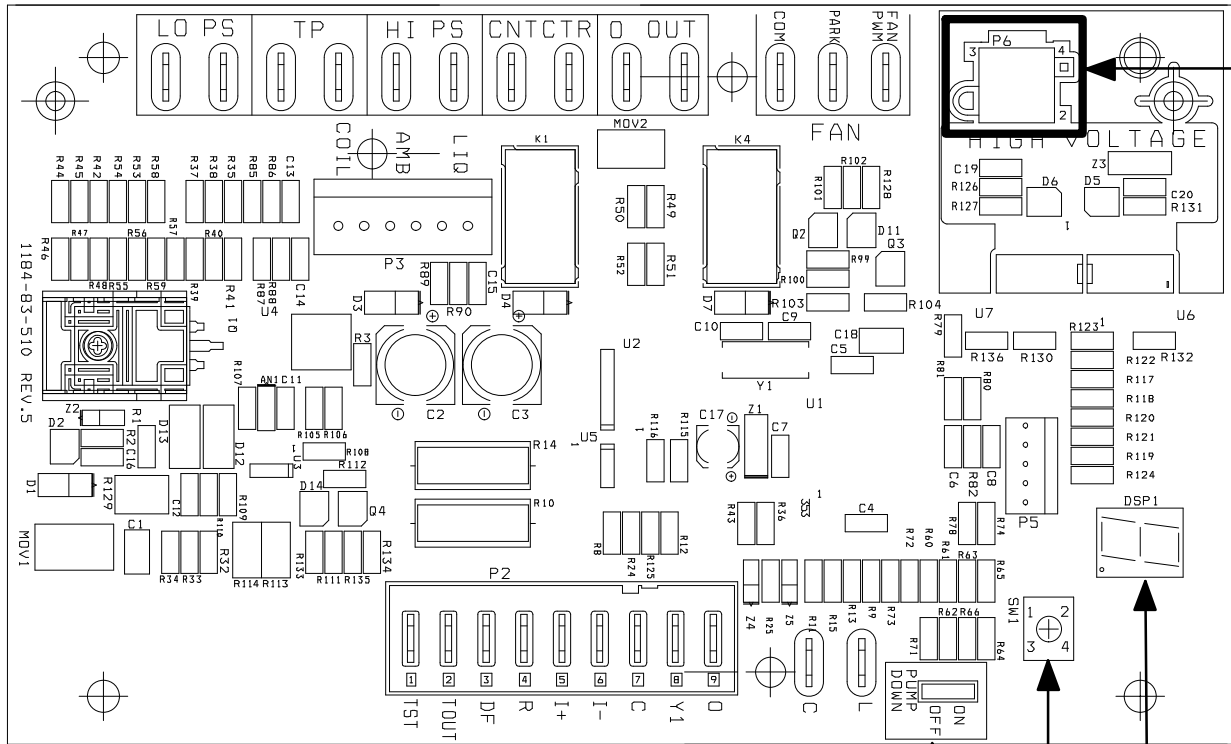

DESIG.	DESCRIPTION	INPUT	OUTPUT
O OUT	REVERSING VALVE SWITCHED 24VAC		X
O OUT	REVERSING VALVE COMMON		X
CNTCTR	COMPRESSOR CONTACTOR SWITCHED 24VAC		X
CNTCTR	COMPRESSOR CONTACTOR COMMON		X
TP	THERMAL PROTECTOR SWITCH 24VAC RETURN	X	
TP	THERMAL PROTECTOR SWITCH 24VAC IN SERIES WITH HIGH PRESSURE SWITCH		X
FAN PWM	PWM FAN OUTPUT		X
FAN PARK	PWM FAN COMMON SPOT FOR UNUSED TERMINAL		X
COM	PWM FAN COMMON CONNECTION		X
HI PS	HIGH PRESSURE SWITCH 24VAC IN SERIES WITH CONTACTOR OUTPUT		X
HI PS	HIGH PRESSURE SWITCH 24VAC RETURN	X	
LO PS	LOW PRESSURE SWITCH SENSING VOLTAGE SUPPLY (2.4ma @ 18VAC)		X
LO PS	LOW PRESSURE SWITCH RETURN	X	
L	LOAD SHEDDING 24VAC INPUT	X	
C	LOAD SHEDDING COMMON		X

DESIG.	DESCRIPTION	INPUT	OUTPUT
LIQ	LIQUID LINE TEMPERATURE SENSOR SUPPLY		X
LIQ	LIQUID LINE TEMPERATURE SENSOR RETURN	X	
AMB	OUTDOOR AMBIENT TEMPERATURE SENSOR RETURN		X
AMB	OUTDOOR AMBIENT TEMPERATURE SENSOR SUPPLY	X	
COIL	OUTDOOR COIL TEMPERATURE SENSOR RETURN		X
COIL	OUTDOOR COIL TEMPERATURE SENSOR SUPPLY	X	

PUMP DOWN - WHEN UNIT IS IN PUMP DOWN MODE, Pd WILL BE DISPLAYED ON 7-SEGMENT.

TO ACTIVATE PUMP DOWN MODE, THE CONTROL MUST BE IN THE IDLE STATE, AND THE PUMP DOWN JUMPER PLACED ACROSS THE TWO PUMP DOWN PINS. TO DEACTIVATE, REMOVE JUMPER.

DESIG.	DESCRIPTION	INPUT	OUTPUT
TST	OEM TEST PIN	X	
TO	26VDC OUTPUT		X
DF	OEM TEST PIN	X	
R	NOMINAL 24VAC	X	
i+	RSBUS DATA HIGH	X	X
i-	RSBUS DATA LOW	X	X
C	NOMINAL 24VAC COMMON	X	
YI	LEGACY 24VAC EMERGENCY INPUT	X	
O	LEGACY 24VAC EMERGENCY INPUT	X	

DESIG.	DESCRIPTION	PIN	INPUT	OUTPUT
RX	RECEIVE DATA FROM INVERTER	1	X	
TX	TRANSMIT DATA TO INVERTER	3		X
INV GND	INVERTER GROUND	2		X
INV 5V	INVERTER 5 VOLTS	4	X	

FIGURE 10

4 ROUTE CONTROL WIRES

Maximum length of wiring (18 gauge) for all connections on the RSBus is 1500 feet (457 meters). Wires should be color-coded, with a temperature rating of 95°F (35°C) minimum, and solid-core (Class II Rated Wiring). All low voltage wiring must enter unit through provided field-installed busing installed in electrical inlet.

The icomfort Wi-Fi® thermostat requires four thermostat wires between the thermostat and the furnace / air handler icomfort™ control and four wires between the outdoor unit and the furnace/air handler icomfort™ control. When a thermostat cable with more than four wires is used, the extra wires must be properly connected to avoid electrical noise (see below).

Use a wire nut to bundle the four unused wires at each end of the cable. Each bundle should also include an additional wire that should be connected to each end to the C terminal as shown in the figure below.

ELECTRICAL (CONTROL WIRING) AND LINE SET INLETS USE BUSHING AND GROMMETS PROVIDED IN BAG

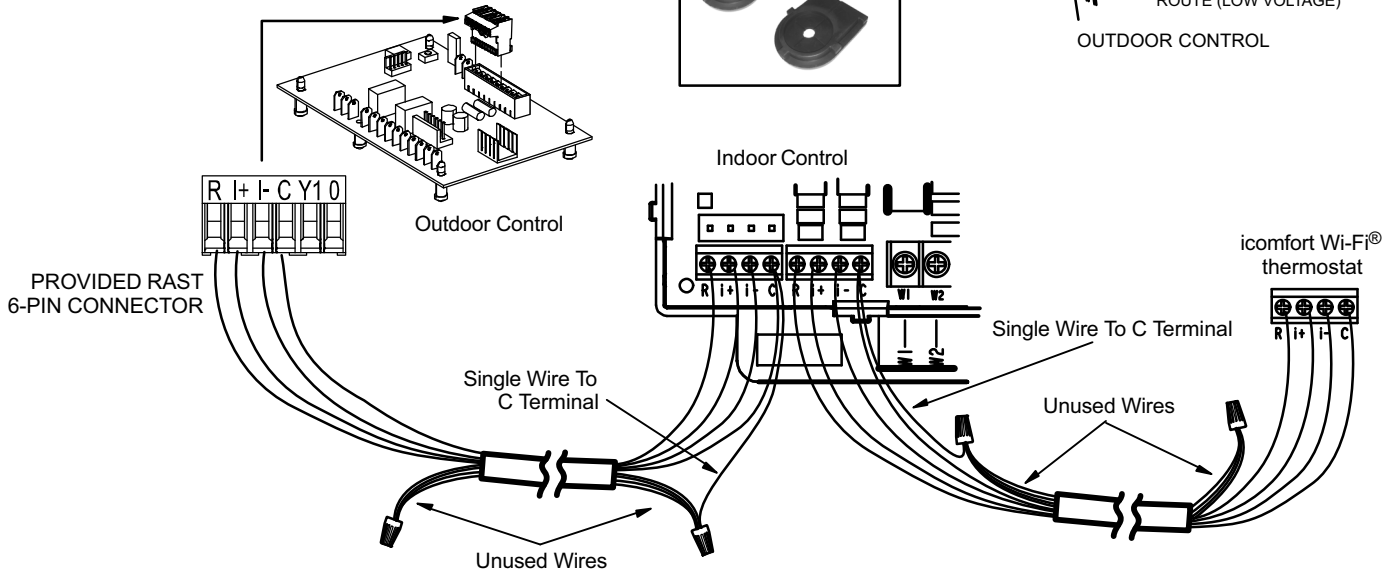
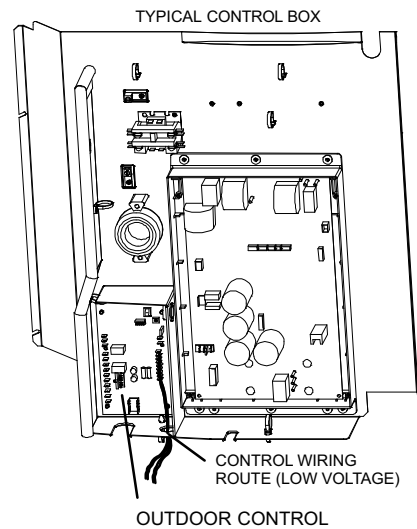
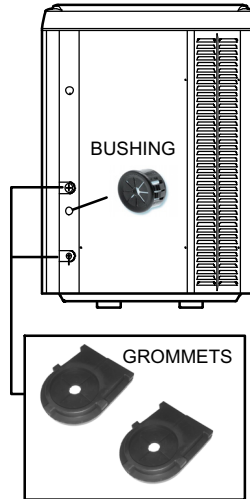

5 ROUTE HIGH VOLTAGE AND GROUND WIRES

Any excess high voltage field wiring should be trimmed and secured away from any low voltage field wiring. To facilitate a conduit, a cutout is located side panel of the control box. Connect conduit to the control box using a proper conduit fitting.

NOTE - Grounding wire must be a single, continuous wire run from unit ground lug to earth ground. DO NOT splice wire.

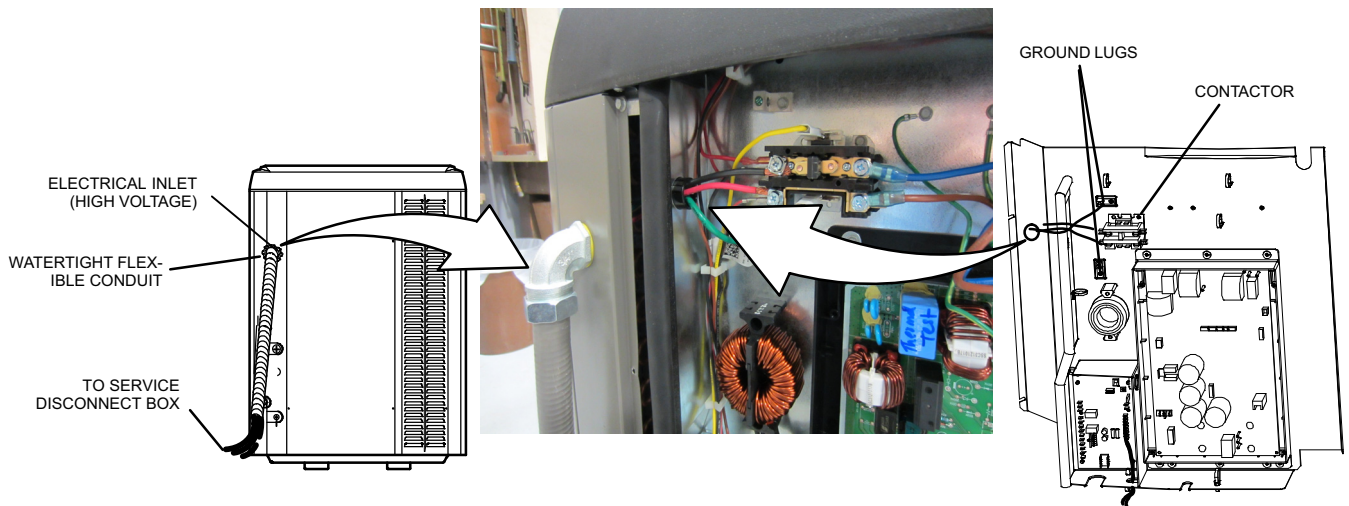

FIGURE 11

Charging

The XC25 unit is factory-charged with enough HFC-410A refrigerant to accommodate a 15-foot length of refrigerant piping. Charge should be checked and adjusted using the tables provided on the charging procedure sticker located on the unit access panel. Detailed charging information is provided in the XC25 Installation and Service Procedures Corp. 1253-L11, which is available on DaveNet.

IMPORTANT !

Room thermostat must be turned down at least 5°F from set point so charging occurs with system operating at 100% capacity. Seven-segment display on outdoor control will show outdoor unit running capacity.

Alarms

Alarm information is provided on the outdoor unit access panel and in the icomfort Wi-Fi® Installer's System Setup Guide. Detail alarm information is also available in the XC25 Installation and Service Procedures Corp. 1253-L11, which is available on DaveNet.

Outdoor Control Seven-Segment Display and Push Button

Information concerning the outdoor control seven-segment display and push button operations are available on the unit access panel and in the XC25 Installation and Service Procedures Corp. 1253-L11.

System Component Configuration (Outdoor Unit)

All configuration of the outdoor unit is completed using the icomfort Wi-Fi® thermostat. Please refer to the icomfort Wi-Fi® Installer's System Setup Guide for complete details on how to integrate this unit into a icomfort™-enabled system.

Homeowner Information

⚠ CAUTION

Before attempting to perform any service or maintenance, turn the electrical power to unit OFF at disconnect switch.

Cleaning of the outdoor unit's coil should be performed by a licensed professional service technician (or equivalent). Contact your dealer and set up a schedule (preferably twice a year, but at least once a year) to inspect and service your outdoor unit. The following maintenance may be performed by the homeowner.

IMPORTANT !

Sprinklers and soaker hoses should not be installed where they could cause prolonged exposure to the outdoor unit by treated water. Prolonged exposure of the unit to treated water (i.e., sprinkler systems, soakers, waste water, etc.) will corrode the surface of steel and aluminum parts, diminish performance and affect longevity of the unit.

Outdoor Coil

The outdoor unit must be properly maintained to ensure its proper operation.

- Please contact your dealer to schedule proper inspection and maintenance for your equipment.
- Make sure no obstructions restrict airflow to the outdoor unit.
- Grass clippings, leaves, or shrubs crowding the unit can cause the unit to work harder and use more energy.
- Keep shrubbery trimmed away from the unit and periodically check for debris which collects around the unit.
- Keep snow level below the louvered panels to ensure proper performance.

Routine Maintenance

In order to ensure peak performance, your system must be properly maintained. Clogged filters and blocked airflow prevent your unit from operating at its most efficient level.

NOTE — The filter and all access panels must be in place any time the unit is in operation. If you are unsure about the filter required for your system, call your Lennox dealer for assistance.

1. Ask your Lennox dealer to show you where your indoor unit's filter is located. It will be either at the indoor unit (installed internal or external to the cabinet) or behind a return air grille in the wall or ceiling. Check the filter monthly and clean or replace it as needed.
2. Disposable filters should be replaced with a filter of the same type and size.
3. The indoor evaporator coil is equipped with a drain pan to collect condensate formed as your system removes humidity from the inside air. Have your dealer show you the location of the drain line and how to check for obstructions. (This would also apply to an auxiliary drain, if installed.)

Thermostat Operation

See the icomfort Wi-Fi® thermostat homeowner manual for instructions on how to operate your thermostat.

Preservice Check

If your system fails to operate, check the following before calling for service:

- Verify room thermostat settings are correct.
- Verify that all electrical disconnect switches are ON.
- Check for any blown fuses or tripped circuit breakers.
- Verify unit access panels are in place.
- Verify air filter is clean.
- If service is needed, locate and write down the unit model number and have it handy before calling.

XC25 Start-Up and Performance Checklist

Customer _____ Address _____

Indoor Unit Model _____ Serial _____

Outdoor Unit Model _____ Serial _____

Solar Module Mfg and Model _____ Serial _____

Notes: _____

START-UP CHECKS

Refrigerant Type: _____

Rated Load Amps _____ Actual Amps _____ Rated Volts _____ Actual Volts _____

Condenser Fan Full Load Amps _____ Actual Amps: _____

COOLING MODE

Vapor Pressure: _____ Liquid Pressure: _____

Supply Air Temperature: _____ Ambient Temperature: _____ Return Air Temperature: _____

HEATING MODE

Vapor Pressure: _____ Liquid Pressure: _____

Supply Air Temperature: _____ Ambient Temperature: _____ Return Air Temperature: _____

System Refrigerant Charge (Refer to manufacturer's information on unit or installation instructions for required subcooling and approach temperatures.)

Subcooling:

$$\text{Saturated Condensing Temperature (A)} - \text{Liquid Line Temperature (B)} = \text{SUBCOOLING}$$

Approach:

$$\text{Liquid Line Temperature (A)} - \text{Outdoor Air Temperature (B)} = \text{APPROACH}$$

Indoor Coil Temp. Drop (18 to 22°F)

$$\text{Return Air Temperature (A)} - \text{Supply Air Temperature (B)} = \text{COIL TEMP DROP}$$