



© 2013 Lennox Industries Inc.  
Dallas, Texas, USA



# INSTALLATION INSTRUCTIONS

## Dave Lennox *Signature*<sup>®</sup> Collection 15GCSX Units

**GAS PACKAGED UNITS (2-5 TONS)**  
507019-01  
4/2013  
Supersedes 72012

**TP** Technical  
Publications  
Litho U.S.A.

### THIS MANUAL MUST BE LEFT WITH THE HOMEOWNER FOR FUTURE REFERENCE

These installation instructions are intended as a general guide only, for use by an experienced, qualified contractor.

### **⚠ WARNING**

Improper installation, adjustment, alteration, service or maintenance can cause personal injury, loss of life, or damage to property.

Installation and service must be performed by a licensed HVAC professional installer (or equivalent), service agency or the gas supplier.

### **⚠ IMPORTANT**

This unit is charged with HFC-410A refrigerant. Operating pressures for units charged with HFC-410A are higher than pressures in units charged with HCFC-22. All service equipment **MUST** be rated for use with HFC-410A refrigerant.

### General

The 15GCSX units are single-package air conditioners with two-stage gas heat designed for outdoor installation on a rooftop or a slab. This unit is not approved for installation as part of a zoning system

The unit must be sized based on heat loss and heat gain calculations made according to the methods of the Air Conditioning Contractors of America (ACCA).

The units are shipped assembled. All piping, refrigerant charge, and electrical wiring are factory-installed and tested. The units require electric power, gas piping, condensate drain and duct connections at the point of installation. In addition, the heating vent hood must be installed before the unit is placed into operation

### Shipping and Packing List

- 1 - Assembled gas package unit
- 1 - Vent hood assembly with screen and screws

As soon as the unit is received, it should be inspected for possible damage during transit. If you find any damage, immediately contact the last carrier.



### **⚠ WARNING**

**FIRE OR EXPLOSION HAZARD.**

Failure to follow safety warnings exactly could result in serious injury, death, or property damage.



GAS-FIRED



Do not store or use gasoline or other flammable vapors and liquids in the vicinity of this or any other appliance.

Installation and service must be performed by a qualified installer, service agency or the gas supplier.

### WHAT TO DO IF YOU SMELL GAS:

- Do not try to light any appliance.
- Do not touch any electrical switch; do not use any phone in your building.
- Leave the building immediately.
- Immediately call your gas supplier from a neighbor's phone. Follow the gas supplier's instructions.
- If you cannot reach your gas supplier, call the fire department.

4/2013



507019-01



# 15GCSX Unit Dimensions - inches (mm)

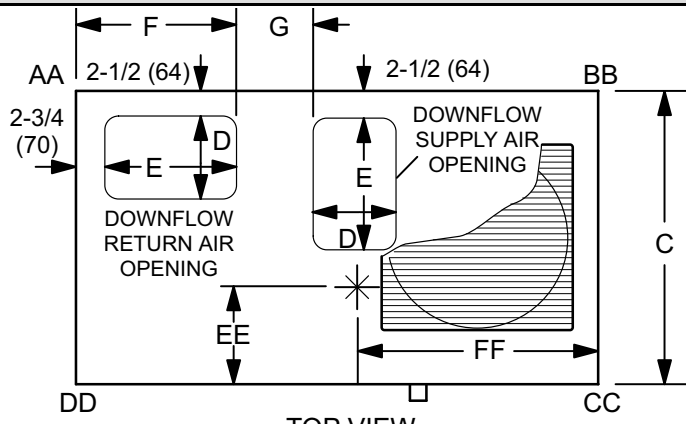

Model Number	Corner Weights				Center Of Gravity	
	AA lbs.	BB lbs.	CC lbs.	DD lbs.	EE in.	FF in.
15GCSXAV-24	74	94	125	97	15.5	28.5
15GCSXAV-30	74	94	125	97	15.5	28.5
15GCSXAV-36	84	101	126	105	16	29.5
15GCSXAV-42	108	136	176	140	20	33
15GCSX(A,B)V-48	112	137	177	144	20	33.5
15GCSX(A,B)V-60	117	143	184	151	20	33.5

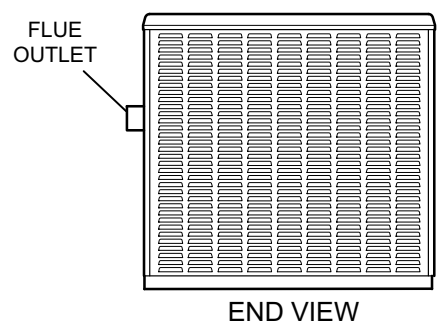
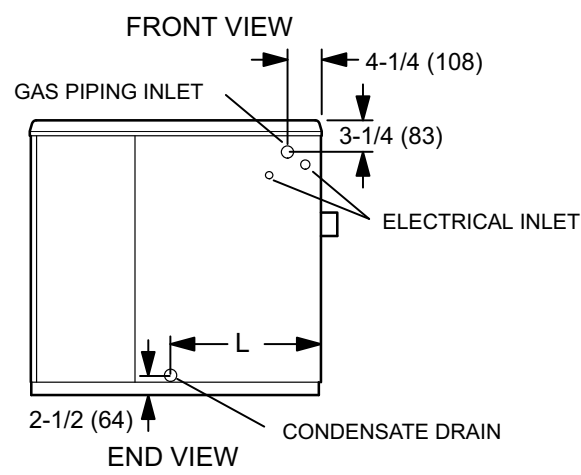
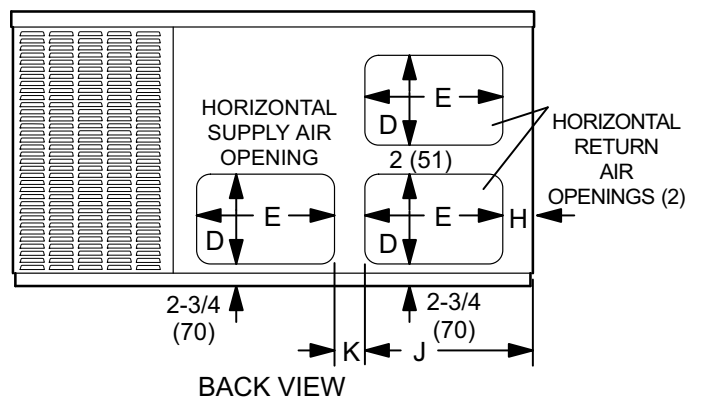
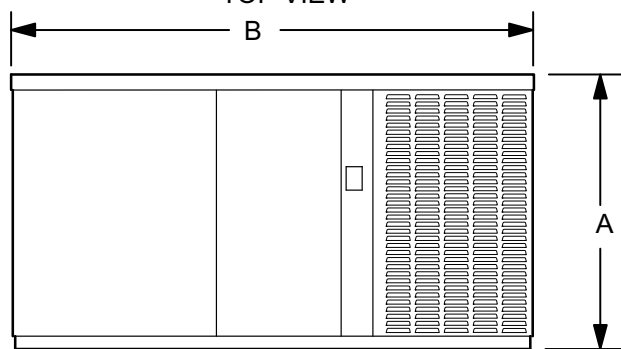

Model No.	A		B		C		D		E		F	
	in.	mm	in.	mm	in.	mm	in.	mm	in.	mm	in.	mm
15GCSXAV-24												
15GCSXAV-30	34-1/4	870	65-3/8	1661	36-1/2	927	11-1/4	286	17-1/4	438	20	508
15GCSXAV-36												
15GCSXAV-42												
15GCSX(A,B)V-48	38-1/4	972	75	1905	46	1168	11-1/4	286	19-1/4	489	22	559
15GCSX(A,B)V-60												

Model No.	F		G		H		J		K		L	
	in.	mm	in.	mm	in.	mm	in.	mm	in.	mm	in.	mm
15GCSXAV-24												
15GCSXAV-30	20	508	8-1/2	216	3	76	20-1/4	514	4-1/2	114	19	483
15GCSXAV-36												
15GCSXAV-42												
15GCSX(A,B)V-48	22	559	9-1/4	241	3-1/4	83	22-1/4	572	4	102	16-1/4	413
15GCSX(A,B)V-60												

## Safety Information

### ⚠ CAUTION

As with any mechanical equipment, personal injury can result from contact with sharp sheet metal edges. Be careful when you handle this equipment.

### ⚠ WARNING

The State of California has determined that this product may contain or produce a chemical or chemicals, in very low doses, which may cause serious illness or death. It may also cause cancer, birth defects, or reproductive harm.

These units must be installed in accordance with all applicable national and local safety codes.

These instructions are intended as a general guide and do not supersede local codes in any way. Consult authorities having jurisdiction before installation.

If components are to be added to a unit to meet local codes, they are to be installed at the dealer's and/or customer's expense.

These units are design listed by UL in both the United States and Canada as follows:

- For use as a forced air furnace with cooling.
- For outdoor installation only.
- For installation on combustible material.
- For use with natural gas or L.P./propane gas only. Use of L.P./propane gas requires installation of an L.P. conversion kit, which must be ordered separately.

**These units are not suitable for use with conventional venting systems.**

The following safety requirements must also be met when the 15GCSX units are installed:

- 1 - Use only with the type of fuel approved for use with this appliance. Refer to the unit rating plate.
- 2 - Position, locate and install the 15GCSX unit only as outlined in these instructions.
- 3 - Provide adequate clearance around the vent hood as specified in these instructions.
- 4 - Do not use an open flame to check for gas leaks. Use a commercially available soap solution, which has been designed specifically to check for gas leaks. Refer to the Gas Supply and Piping section.
- 5 - Check the unit operation after start-up to make sure that the 15GCSX is operating within the intended temperature rise range. The duct system must be designed to provide an external static pressure within the allowable range. Refer to the unit rating plate.

Lennox does not recommend the use of 15GCSX units as a construction heater during any phase of construction. Very low return air temperatures, harmful vapors and operation of the unit with clogged or misplaced filters will damage the unit.

15GCSX units may be used for heating of buildings or structures under construction, if the following conditions are met:

- *The vent hood must be installed per these installation instructions.*
- *A room thermostat must control the furnace. The use of fixed jumpers that will provide continuous heating is not allowed.*
- *The return air duct must be provided and sealed to the furnace.*
- *Return air temperature range between 60°F (16°C) and 80°F (27°C) must be maintained.*
- *Air filters must be installed in the system and must be maintained during construction.*
- *Air filters must be replaced upon construction completion.*
- *The input rate and temperature rise must be set per the unit rating plate.*
- *One hundred percent (100%) outdoor air must be provided for combustion air requirements during construction. Unit is approved for outdoor installation only.*
- *The heat exchanger, components, duct system, air filters and evaporator coil must be thoroughly cleaned following final construction clean-up.*
- *The unit operating conditions (including ignition, input rate, temperature rise and venting) must be verified according to these installation instructions.*

**NOTE - The Commonwealth of Massachusetts stipulates these additional requirements:**

- **Gas furnaces shall be installed by a licensed plumber or gas fitter only.**
- **The gas cock must be "T handle" type.**
- **When flexible connectors are used, the maximum length shall not exceed 36".**
- **This unit is not approved for installation as part of a zoning system.**

## Location Selection

Use the following guidelines to select a suitable location for these units.

- 1 - Unit is designed for outdoor installation only. Unit must be installed so all electrical components are protected from water.
- 2 - Condenser coils must have an unlimited supply of air.
- 3 - For ground level installation, use a level pre-fabricated pad or use a level concrete slab with a minimum thickness of 4 inches. The length and width should be at least 6 inches greater than the unit base. Do not tie the slab to the building foundation.
- 4 - Maintain level within a tolerance of 1/4 inch maximum across the entire length or width of the unit.
- 5 - Do not locate the unit where the combustion air supply will be exposed to any corrosive substance, including the following:
  - Permanent wave solutions
  - Chlorinated waxes or cleaners
  - Chlorine-based swimming pool chemicals
  - Water-softening chemicals

- De-icing salts or chemicals
- Carbon tetrachloride
- Halogen-type refrigerants
- Cleaning solvents (e.g., perchloroethylene)
- Printing inks, paint removers, varnishes, etc.
- Cements and glues
- Anti-static fabric softeners used in clothes dryers
- Masonry acid-washing materials
- Chlorinated laundry products
- Hydrochloric acid

### Rigging and Setting Unit

Exercise care when moving the unit. Do not remove any packaging until the unit is near the place of installation. An optional lifting lug kit (92M51) may be purchased separately for use in rigging the unit for lifting. **The spreader lengths must exceed the width across the top of the unit.** Recommended spreader lengths: for use with 2, 2-1/2 and 3-ton units -- 44"; for use with 3-1/2, 4 and 5-ton units -- 54".

### ⚠ CAUTION

Before lifting a unit, make sure that the weight is distributed equally on the cables so that it will lift evenly.

### Accessory Lift Kit

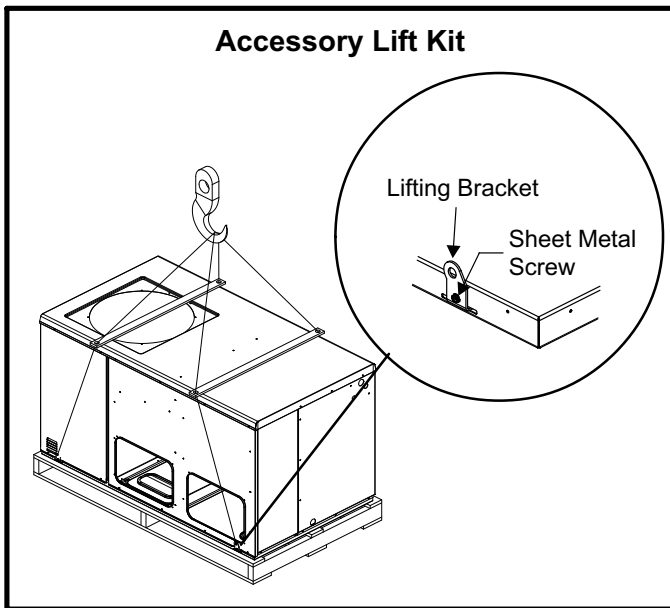

Figure 1

Units may also be moved or lifted with a forklift while still in the factory supplied packaging.

NOTE - Length of forks must be a minimum of 42 inches.

### Clearances

All units require certain clearances for proper operation and service. Refer to figure 2 for the clearances required for combustible construction, servicing, and proper unit operation.

NOTE - Do not permit overhanging structures or shrubs to obstruct condenser air discharge outlet or vent outlet.

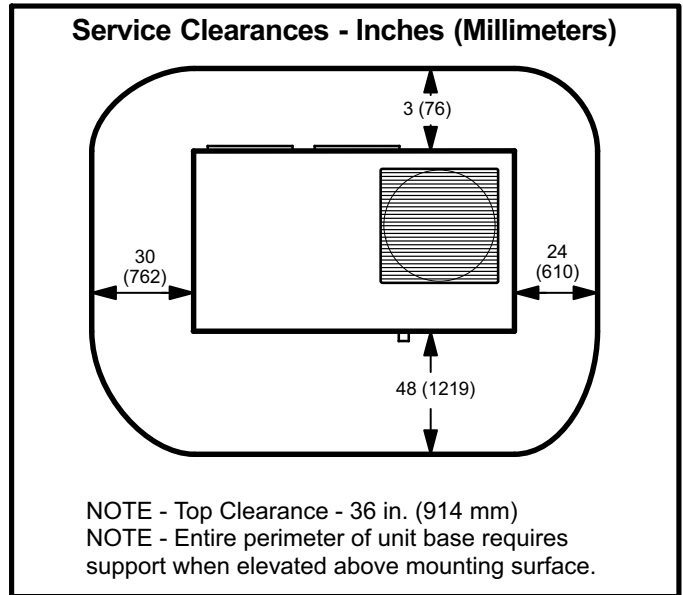

Figure 2

In the U.S. units may be installed on combustible flooring made from wood or class A, B, or C roof covering material. In Canada, units may be installed on combustible flooring.

The products of combustion are discharged through a screened vent outlet in the front mullion.

Install the unit so that the products of combustion will not damage the outer building structure.

The vent outlet must be at least 4 feet below, 4 feet horizontally from and 1 foot above any door, window or gravity air inlet into the building. In addition, install the unit so that the vent outlet is at least 3 feet above any forced air inlet located within 10 feet.

Clearances to the vent outlet must also be consistent with the requirements of the current National Fuel Gas Code (Z223.1) and/or the standards of the current CSA B149 codes.

Figure 3 shows the minimum clearances to combustibles required above and below the vent hood. The minimum clearance in front of the vent hood is 24 inches.

Install the unit so that snow accumulation will not restrict the flow of the flue products. Allow a required minimum horizontal clearance of 4 feet from electric meters, gas meters, regulators and relief equipment. In addition to the above requirements, ensure that unwanted ice caused by condensate is not allowed to accumulate around the unit. Do not locate the unit on the side of the building where the prevailing winter winds could trap moisture, causing it to freeze on the walls or on overhangs (under eaves). The vent outlet should not discharge flue products on a sidewalk, patio or other walkway where the condensate could cause the surface to become slippery.

**Do not install the unit so that the products of combustion will be allowed to accumulate within a confined space and recirculate.**

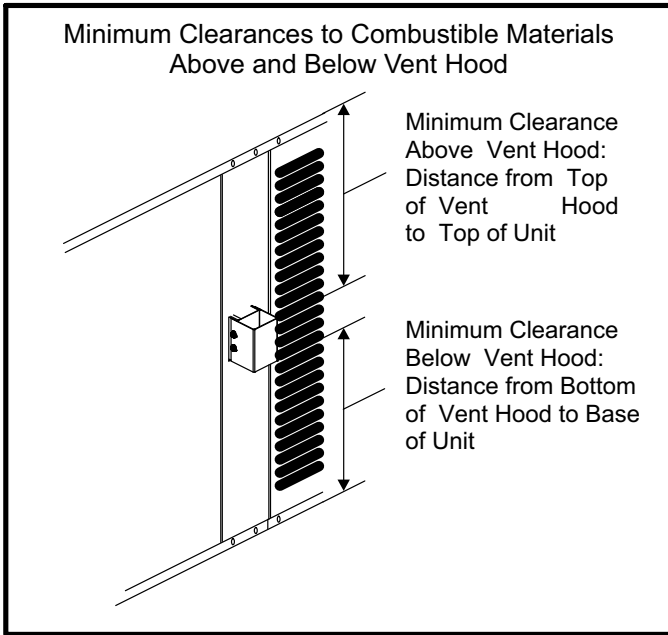

Figure 3

### Vent Hood Installation

The vent hood, screen and screws are shipped inside the unit in the plastic bag which contains the installation instructions.

- 1 - Insert the vent screen into the vent tube. Once inserted, the screen should be flush with the end of the tube as shown in figure 4.

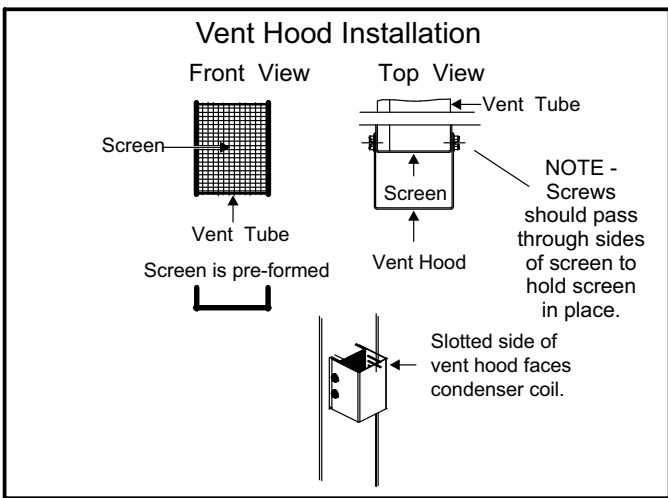

Figure 4

- 2 - Position the vent hood over the vent tube so that the slotted side of the hood faces the condenser coil. Use the four sheet metal screws (provided) to secure the vent hood to the vent tube. The screws should pass through the sides of the screen in order to hold the screen in place.

**The vent hood must be installed prior to unit start-up.**

### Existing Common Vent Systems

If this packaged outdoor unit is replacing an existing indoor furnace that is being removed from a venting system commonly run with a water heater or other gas appliance, the venting system is likely to be too large to properly vent the remaining attached appliance(s).

Conduct the following test while the water heater is operating and the other gas appliances (which are not operating) remain connected to the common venting system.

- 1 - Seal any unused openings in the common venting system.
- 2 - Inspect the venting system for proper size and horizontal pitch. Determine that there is no blockage, restriction, leakage, corrosion, or other deficiencies which could cause an unsafe condition.
- 3 - Close all building doors and windows and all doors between the space in which the appliances remaining connected to the common venting system are located and other spaces of the building. Turn on clothes dryers and any appliances not connected to the common venting system. Turn on any exhaust fans, such as range hoods and bathroom exhausts, so they will operate at maximum speed. Do not operate a summer exhaust fan. Close fireplace dampers.
- 4 - Follow the lighting instructions. Turn on the appliance that is being inspected. Adjust the thermostat so that the appliance operates continuously.
- 5 - After the burner has operated for 5 minutes, test for leaks of flue gases at the draft hood relief opening. Use the flame of a match or candle, or smoke from a cigarette, cigar, or pipe.
- 6 - After determining that each appliance connected to the common venting system is venting properly, (step 3) return all doors, windows, exhaust fans, fireplace dampers, and any other gas-burning appliances to their previous mode of operation.

- 7 - If a venting problem is found during any of the preceding tests, the common venting system must be modified to correct the problem.

If necessary, you must resize the common venting system to the minimum vent pipe size determined by using the appropriate tables in Appendix G. (These are in the current standards of the National Fuel Gas Code ANSI-Z223.1/NFPA 54 in the USA, and the appropriate Category 1 Natural Gas and Propane appliances venting sizing tables in the current standards of the CSA B149 Natural Gas and Propane Installation Codes in Canada.)

### Condensate Drain

The 15GCSX unit is equipped with a 3/4 inch FPT coupling for condensate line connection. Plumbing must conform to local codes. Use a sealing compound on male pipe threads.

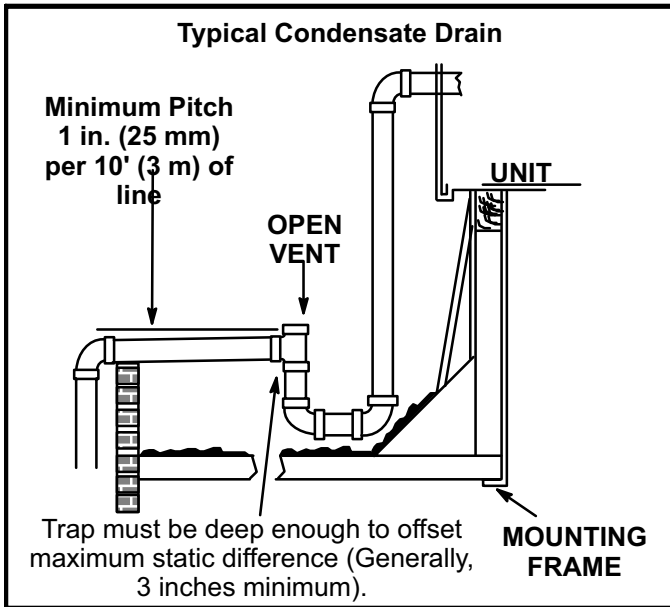

Figure 5

The drain line must be properly trapped and routed to a suitable drain. See figure 5 for proper drain arrangement. The drain line must pitch to an open drain or pump a minimum of 1 inch per 10 feet to prevent clogging of the line. The drain line must be supported so that weight of drain line is not carried by drain line connection. Seal around drain connection with suitable material to prevent air leakage into return air system.

Drain piping should not be smaller than drain connection at coil. An open vent in drain line will some times be required due to line length, friction and static pressure. Drains should be constructed in a manner to facilitate future cleaning.

*NOTE - The condensate drain line MUST be trapped to provide proper drainage.*

**⚠ CAUTION**

Condensate line connection must be hand-tightened. Do not use tools.

**Filters**

Filters are not factory-supplied with the unit; however, optional internally installed filter kits are available. Filter kit 92M54 is used with 2, 2-1/2 and 3-ton units. Filter kit 92M55 is used with 3-1/2, 4 and 5-ton units. The filter kits accommodate the use of 1", 2" or 4" filters. If the optional filter kit is not used, a filter must be field-installed.

Filters must always be installed ahead of evaporator coil and must be kept clean or replaced. Dirty filters will reduce the airflow of the unit. Filter sizes are shown in table 1.

Table 1. Unit Filter Size

Unit Model	Filter Size	Filter Quantity
-24, -30, -36	20 in. X 25 in.	1
-42, -48, -60	16 in. X 25 in.	2

The Healthy Climate® PureAir® air purification system (PCO20-28) may be used with 15GCSX units installed in horizontal air discharge applications only. Installation hardware kit (Y0629) is required to install the PCO20-28 (X8787) in the packaged unit. The PCO20-28 is designed for universal voltage, and is ready to operate at 208/230V. When used, the PCO should be installed before the unit is set in place and before the duct connections are made.

**Supply & Return Duct Connections**

The duct system should be designed and sized according to the methods in Manual Q of the Air Conditioning Contractors of America (ACCA).

A closed return duct system shall be used. This shall not preclude use of economizers or outdoor fresh air intake. It is recommended that supply and return duct connections at the unit be made with flexible joints.

The supply and return air duct systems should be designed for the CFM and static requirements of the job. **They should NOT be sized by simply matching the dimensions of the duct connections on the unit.**

**⚠ CAUTION**

When fastening duct system to side duct flanges on unit, insert screws through duct flanges only. Do not insert screws through casing. Outdoor duct must be insulated and waterproofed.

The 15GCSX unit is shipped ready for horizontal air discharge (side duct connections). If bottom air discharge is desired, the covers must be removed from the supply and return air openings on the bottom of the unit and re-installed to cover the side openings.

The upper return air opening cover must be removed when the PureAir® air purification system (PCO20-28) is being used. In PCO applications, both upper and lower return air openings must be covered by the return air plenum to ensure proper PCO operation. The upper return air opening is not required in horizontal applications when the PCO is not used.

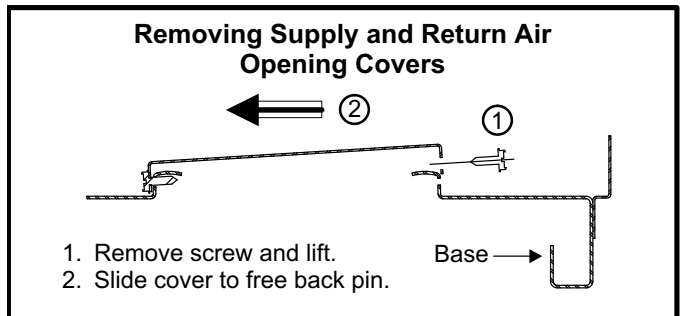

Figure 6

## Compressors

Units are shipped with the compressor mountings factory-adjusted and ready for operation.

**⚠ CAUTION**

Do not loosen compressor mounting bolts.

## Gas Supply and Piping

Check the unit rating plate to confirm whether unit is equipped for use with natural gas or LP/propane. If conversion is required use the approved conversion kit.

*NOTE - Units are shipped equipped for natural gas, but can be converted to LP/propane with a conversion kit. **Conversion must be performed by an approved licensed pipe fitter or technician.***

All LP/propane gas equipment must conform to the safety standards of the National Fire Protection Association.

Complete information regarding tank sizing for vaporization, recommended regulator settings, and pipe sizing is available from most regulator manufacturers and LP/propane gas suppliers.

Proper sizing of gas piping depends on the cubic feet per hour of gas flow required, specific gravity of the gas and length of run. In the United States, the current National Fuel Gas Code Z223.1 should be followed in all cases unless superseded by local codes or gas company requirements. Refer to tables 2 and 3. In Canada, refer to the current CSA B.149 installation codes.

**Table 2. Gas Heat Application Data**

Unit Heating Size	Input Rating (Btu)	Output Rating (Btu)	Gas Capacity* (FT <sup>3</sup> / HR)
68	67,500	54,000	63
83	82,500	66,000	77
90	90,000	72,000	84
110	110,000	88,000	102
138	137,500	110,000	128

*\*Based on 1075 Btu per cubic foot of natural gas.*

Before connecting piping, check with gas company or authorities having jurisdiction for local codes or requirements. When installing gas supply piping, length of run from gas meter must be considered in determining pipe size for 0.5 inch w.c. maximum pressure drop. Do not use supply pipe smaller than unit gas connection. For natural gas unit, supply pressure at the unit gas connection must be a minimum of 5 inches w.c. and a maximum of 10.5 w.c. For LP/propane gas units, supply pressure at the unit gas connection must be a minimum of 11 inches w.c. and a maximum of 13.0 inches w.c.

**Table 3. Gas Pipe Capacity-FT<sup>3</sup> / HR**

Length in Feet	Nominal Iron Pipe Size (inches)			
	1/2 in.	3/4 in.	1 in.	1-1/4 in.
10	132	278	520	1050
20	92	190	350	730
30	73	152	285	590
40	63	130	245	500
50	56	115	215	440
60	50	105	195	400
70	46	96	180	370
80	43	90	170	350
90	40	84	160	320
100	38	79	150	305

The gas supply piping should be routed through the grommet on the side of the unit. Refer to figure 7.

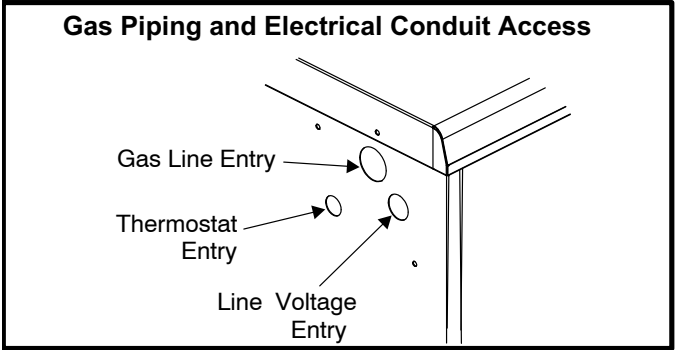

**Figure 7**

When making piping connections, a drip leg should be installed on vertical runs to serve as a trap for sediment or condensate. A 1/8 inch N.P.T. tap accessible for test gauge connection must be provided in field piping upstream from gas supply connection to unit. Install a ground joint union between gas control manifold and the manual main shut-off valve. See figure 8.

Compounds used on threaded joints of gas piping shall be resistant to the action of propane/LP gases.

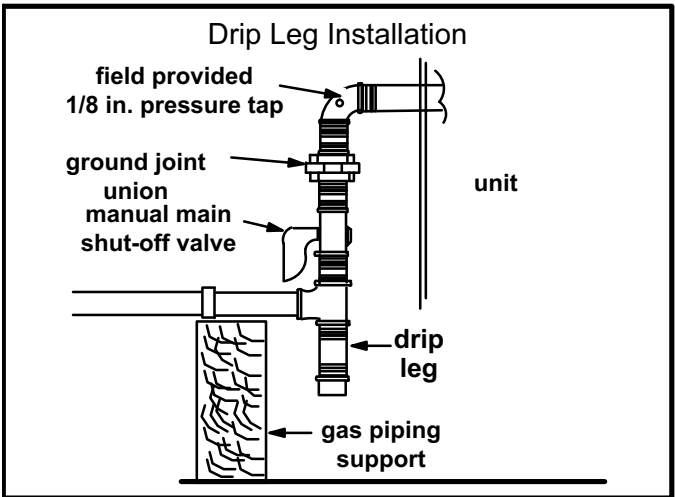

**Figure 8**

**Pressure Test Gas Piping**

*NOTE - Codes may require that manual main shut off valve and union (furnished by installer) be installed in gas line external to unit. Union must be of the ground joint type.*

When pressure testing gas lines, the gas valve must be disconnected and isolated. Gas valve can be damaged if subjected to more than 0.5 psig (14 inch w.c.). See figure 9.

If test pressure is equal to or less than 0.5 psig (14 inch w.c.) shutoff the manual main shut-off valve before pressure testing to isolate unit from gas supply system.

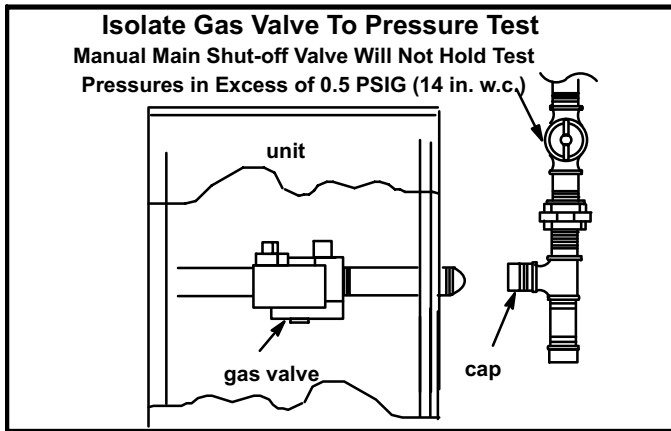

Figure 9

## ⚠ WARNING



Danger of explosion. Can cause injury or product or property damage. Do not use matches, candles, flame or other sources of ignition to check for leaks.

After gas piping is complete, carefully check all piping connections (factory and field) for gas leaks. Use soap solution or other preferred means.

*NOTE - In case of emergency shutdown, shut off main manual gas valve and disconnect main power to unit. These devices should be properly labeled by installer.*

The heating value of the gas may differ with locality. The value should be checked with the local gas utility.

*NOTE - There may be a local gas utility requirement specifying a minimum diameter for gas piping. All units require a 1/2 inch pipe connection at the gas valve.*

Gas piping recommendations:

## ⚠ CAUTION

If a flexible gas connector is required or allowed by the authority that has jurisdiction, black iron pipe shall be installed at the gas valve and must extend outside the cabinet. The flexible connector can then be added between the black iron pipe and the gas supply line.

- 1 - A drip leg and a ground joint union must be installed in the gas piping.  
A ground joint union is recommended by the manifold/valve.
- 2 - When required by local codes, a manual shut-off valve may have to be installed outside of the unit.
- 3 - Use pipe thread sealing compound resistant to propane gas sparingly on male threads.

- 4 - The gas supply should be a separate line and installed in accordance with all safety codes. After the gas connections have been completed, open the main shut-off valve admitting normal gas pressure to the mains. Check all joints for leaks with soap solution or other material suitable for the purpose.

## ⚠ CAUTION

Some soaps used for leak detection are corrosive to certain metals. Carefully rinse piping thoroughly after leak test has been completed. Do not use matches, candles, flame or other sources of ignition to check for gas leaks.

- 5 - The unit and its individual manual shut-off valve must be disconnected from the gas supply piping system during any pressure testing of that system at test pressures in excess of 1/2 PSIG (3.48kPa).

## ⚠ IMPORTANT

The unit must be isolated from the gas supply piping system by closing its individual manual shut-off valve during any pressure testing of the gas supply piping system at test pressures equal to or less than 1/2 psig. See figure 9.

The unit and its individual shut-off valve must be disconnected from the gas supply piping system during any pressure testing of the system at test pressures greater than 1/2 psig.

- 6 - A 1/8 inch N.P.T. plugged tapping, accessible for test gage connections, must be installed immediately upstream of the gas supply connection to the furnace.

## Electrical

**All wiring should be done in accordance with the current National Electric Code ANSI/NFPA No. 70 in the United States. In Canada, wiring must be done in accordance with the current CSA C22.2 Part 1. Local codes may take precedence.**

Use wiring with a temperature limitation of 75°C min.; run the 208 or 230 volt, 60 hertz electric power supply through a fused disconnect switch to control box of unit and connect as shown in the wiring diagram located on the inside of the control access panel.

Unit must be electrically grounded in accordance with local codes or in the absence of local codes with the National Electric Code, ANSI/NFPA No. 70 (latest edition) or CSA C22.2 Part 1 (latest edition).

Power supply to the unit must be N.E.C. Class 1, and must comply with all applicable codes. A fused disconnect switch should be field provided for the unit. The switch must be separate from all other circuits. If any of the wire supplied with the unit must be replaced, replacement wire must be of the type shown on the wiring diagram.

Electrical wiring must be sized to carry minimum circuit ampacity marked on the unit. **USE COPPER CONDUCTORS ONLY.** Each unit must be wired with a separate branch circuit and be properly fused.



## ⚠ CAUTION

When connecting electrical power and control wiring to the unit, waterproof type connectors **MUST** be used so that water or moisture cannot be drawn into the unit during normal operation.

See figure 10 for field connection of line voltage wiring. In addition, refer to the unit typical wiring diagram located on access panel.

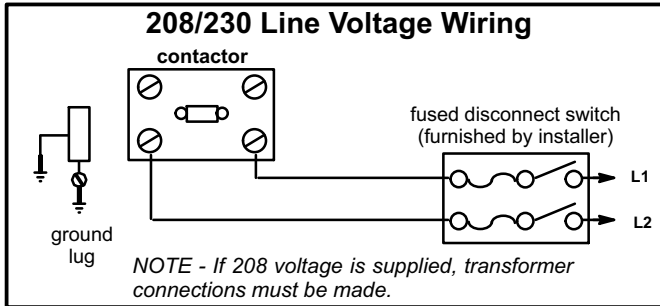

Figure 10

### Thermostat

The room thermostat should be located on an inside wall where it will not be subject to drafts, sun exposure or heat from electrical fixtures or appliances. Follow manufacturer's instructions enclosed with thermostat for general installation procedure. Color coded insulated wires (# 18 AWG) should be used to connect thermostat to unit. Four wires are required for cooling.

### Heat Anticipator Setting

It is important that the anticipator setpoint be correct. Too high of a setting will result in longer heat cycles and a greater temperature swing in the conditioned space. Reducing the value below the correct setpoint will give shorter "ON" cycles and may result in the lowering of the temperature within the conditioned space.

**Heat Anticipator Setting: 0.70 AMP**

## Blower Control (A54)

### ⚠ WARNING



Electric shock hazard. Can cause injury or death. Before attempting to perform any service or maintenance, turn the electrical power to unit OFF at disconnect switch(es). Unit may have multiple power supplies.

15GCSX units are equipped with a variable speed motor that is capable of maintaining a specified CFM throughout the external static range. A particular CFM can be obtained by positioning jumpers (**COOL**, **HEAT**, and **ADJUST**) on the blower control. The HEAT and COOL jumpers are labeled A, B, C and D. Each of the numbers corresponds with an air volume (CFM) setting. The **ADJUST** jumper is labeled Test, -, +, and Norm. The + and - pin settings are used to add or subtract a percentage of the CFM selected. The Test jumper is used to operate the motor in the test mode. See figure 11.

Factory settings for the blower speed jumpers are given in the wiring diagram located on the unit access panel. Figure 11 shows the blower control. Use tables 4, 5 and 6 to determine the correct air volume for operation in heat and cool mode.

The **CFM** LED located on the blower control flashes one time per 100 cfm to indicate selected blower speed. For example, if the unit is operating at 1000 CFM, **CFM** LED will flash 10 times. If the CFM is 1150, **CFM** LED will flash 11 full times plus one fast or half flash.

At times the light may appear to flicker or glow. This takes place when the control is communicating with the motor between cycles. This is normal operation.

Read through the jumper settings section before adjusting the jumper to obtain the appropriate blower speed.

To change jumper positions, gently pull the jumper off the pins and place it on the desired set of pins. The following section outlines the different jumper selections available and conditions associated with each one. Refer to figure 11.

After the CFM for each application has been determined, the jumper settings must be adjusted to reflect those given in tables 4, 5 and 6. From the tables, determine which row most closely matches the desired CFM. Once a specific row has been chosen (+, NORMAL, or -), CFM volumes from other rows cannot be used. Below are descriptions of the jumper selections.

The variable speed motor slowly ramps up to and down from the selected air flow during both cooling and heating demand. This minimizes noise and eliminates the initial blast of air when the blower is initially energized.

### ADJUST

The **ADJUST** pins allow the motor to run at normal speed, approximately 15 percent higher, or approximately 15 percent lower than normal speed. Tables 4, 5 and 6 give three rows (+, NORMAL, and -) with their respective CFM volumes. Notice that the normal adjustment setting for heat speed position C in table 4 is 900 CFM. The + adjustment setting for that position is 1035 CFM and for the - adjustment setting is 765 CFM. After the adjustment setting has been determined, choose the remaining speed settings from those offered in the table in that row.

The TEST pin is available to bypass the blower control and run the motor at approximately 70 percent to make sure that the motor is operational. This is used mainly in troubleshooting. The G terminal must be energized for the motor to run.

### COOL

The **COOL** jumper is used to determine the CFM during cooling operation. This jumper selection is activated for cooling when Y1 is energized.

The blower motor runs at 80 percent of the selected air flow for the first 7-1/2 minutes of each cooling demand. This feature allows for greater humidity removal and saves energy.

In the cooling mode, the blower control delays blower operation for 5 seconds after the compressor starts. The blower continues to operate for 90 seconds after the compressor is de-energized.

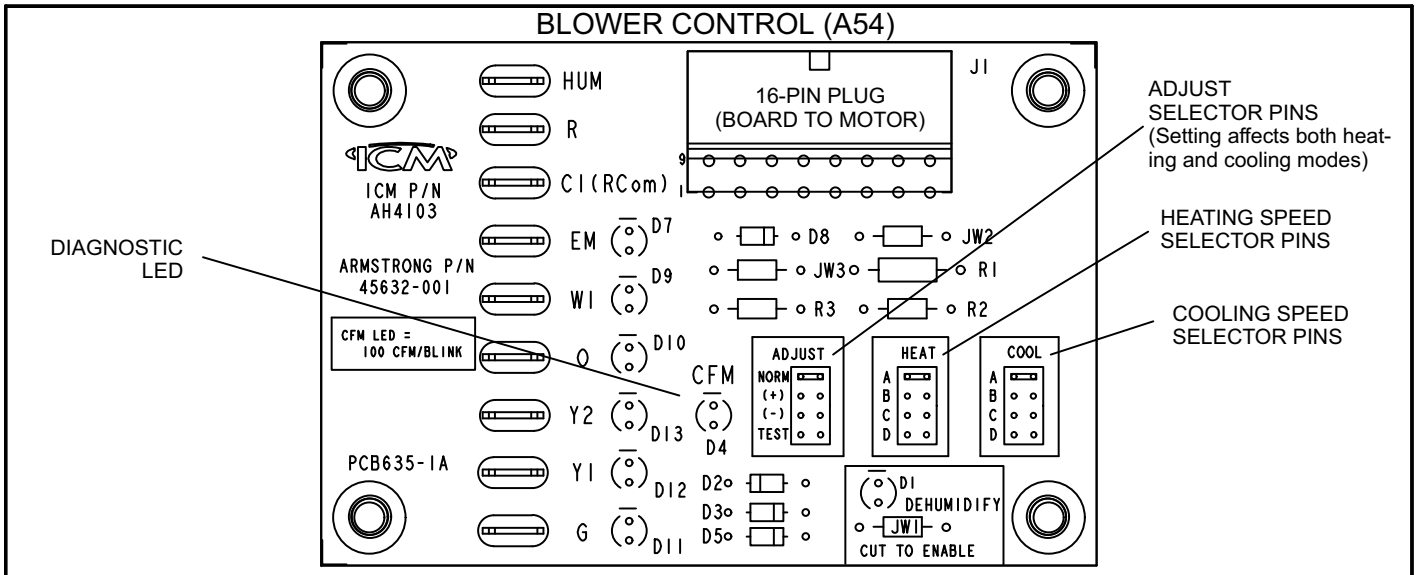

Figure 11

**HEAT**

The **HEAT** jumper is used to determine CFM during gas heat operation only. These jumper selections are activated only when W1 is energized.

In the heating mode, the blower control delays blower operation for 30 seconds after the flame is established. The blower continues to operate for 90 seconds after the gas valve is de-energized.

**CONTINUOUS FAN**

When the thermostat is set for "Continuous Fan" operation and there is no demand for heating or cooling, the blower control will provide 50 percent of the **COOL** CFM selected.

*NOTE - With the proper thermostat and subbase, continuous blower operation is possible by closing the R to G circuit. Cooling blower delay is also functional in this mode.*

**DEHUMIDIFICATION**

The blower control includes an HUM terminal which provides for connection of a humidistat. The JV1 resistor on the blower control must be cut to activate the HUM terminal. The humidistat must be wired to open on humidity rise. When the dehumidification circuit is used, the variable speed motor will reduce the selected air flow rate by 25 percent when humidity levels are high. An LED (D1) lights when the blower is operating in the dehumidification mode.

**Table 4. 15GCSXAV-24, 15GCSXAV-30 Blower Performance**  
0 through 0.80 in. w.g. (0 through 200 Pa) External Static Pressure Range

ADJUST Jumper Setting	Jumper Speed Positions																							
	"COOL" Speed				"HEAT" Speed				"CONTINUOUS FAN" Speed															
	A	B	C	D	A	B	C	D	A	B	C	D												
	cfm	L/s	cfm	L/s	cfm	L/s	cfm	L/s	cfm	L/s	cfm	L/s	cfm	L/s	cfm	L/s								
+	1150	545	920	435	690	325	1035	490	1265	595	1150	545	1035	490	920	435	575	270	460	215	345	165	520	245
NORM	1000	470	800	380	600	285	900	425	1100	520	1000	470	900	425	800	380	500	235	400	190	300	140	450	210
-	850	400	680	320	510	240	765	360	935	440	850	400	765	360	680	320	425	200	340	160	300	140	385	180

**Table 5. 15GCSXAV-36 Blower Performance**  
0 through 0.80 in. w.g. (0 through 200 Pa) External Static Pressure Range

ADJUST Jumper Setting	Jumper Speed Positions																							
	"COOL" Speed				"HEAT" Speed				"CONTINUOUS FAN" Speed															
	A	B	C	D	A	B	C	D	A	B	C	D												
	cfm	L/s	cfm	L/s	cfm	L/s	cfm	L/s	cfm	L/s	cfm	L/s	cfm	L/s	cfm	L/s	cfm	L/s	cfm	L/s	cfm	L/s		
+	1380	650	1150	545	920	435	1265	575	1555	735	1265	595	1150	545	1035	490	690	325	575	270	460	215	635	300
NORM	1200	565	1000	470	800	380	1100	520	1350	635	1100	520	1000	470	900	425	600	285	500	235	400	190	550	260
-	1020	480	850	400	680	320	935	440	1150	540	935	440	850	400	765	360	510	240	425	200	350	165	470	220

**Table 6. 15GCSXAV-42, 15GCSX(A,B)V-48, 15GCSX(A,B)V-60, Blower Performance**  
0 through 0.80 in. w.g. (0 through 200 Pa) External Static Pressure Range

"ADJUST" Jumper Setting	Jumper Speed Positions																							
	"COOL" Speed				"HEAT" Speed				"CONTINUOUS FAN" Speed															
	A		B		C		D		A		B		C		D									
	cfm	L/s	cfm	L/s	cfm	L/s	cfm	L/s	cfm	L/s	cfm	L/s	cfm	L/s	cfm	L/s								
+	2070	975	1840	870	1610	760	1380	650	2015	950	1900	895	1555	735	1325	625	1035	490	920	435	805	380	690	325
NORM	1800	850	1600	755	1400	660	1200	565	1750	825	1650	780	1350	635	1150	545	900	425	800	380	700	330	600	285
-	1530	720	1360	640	1190	560	1020	480	1490	700	1405	660	1150	540	980	460	765	360	680	320	595	280	510	240

**Table 7. Normal Operating Pressures**

80°F db / 67°F wb RETURN AIR		Air Temperature Entering Outdoor Coil (°F)											
UNIT	PRESSURE	65	70	75	80	82	85	90	95	100	105	110	115
15GCSX-24	Suction	142	143	144	146	146	147	148	149	150	151	152	153
15GCSX-30		134	136	138	140	141	142	144	146	148	149	151	152
15GCSX-36		143	144	146	147	148	149	151	152	155	155	157	157
15GCSX-42		140	140	140	141	141	141	142	142	143	144	145	147
15GCSX-48		133	134	136	137	138	139	139	140	141	142	144	145
15GCSX-60		134	136	138	140	141	142	144	145	147	148	150	151
15GCSX-24	Liquid	219	242	264	287	296	310	333	355	379	398	430	457
15GCSX-30		232	255	277	300	309	323	345	368	390	408	440	470
15GCSX-36		244	268	292	316	326	340	363	369	410	429	461	493
15GCSX-42		225	247	269	291	300	314	337	357	383	402	434	457
15GCSX-48		236	256	277	297	305	320	344	370	393	412	449	480
15GCSX-60		246	269	291	314	323	337	360	385	407	424	457	484

### Cooling Start-Up

The cooling section is a complete factory package utilizing an air-cooled condenser. The system is factory-charged with HFC-410A refrigerant. The compressor is hermetically sealed, internally sprung and base-mounted with rubber-insolated hold-down bolts.

#### Pre-Start Check List:

- 1 - Make sure refrigerant lines do not rub against the cabinet or each other.
- 2 - Inspect all electrical wiring, both factory- and field-installed, for loose connections.
- 3 - Check voltage at the disconnect switch. Voltage must be within the range listed on the unit nameplate. If not, consult power company and have voltage condition corrected before starting unit.
- 4 - Recheck voltage with unit running. If power is not within the range listed on the unit nameplate, stop the unit and consult the power company. Check unit amperage. Refer to unit nameplate for correct running amps.
- 5 - Make sure filter is in place before unit start-up.

#### Cooling Sequence of Operation

When the thermostat calls for cooling, **R** is closed to **G** and **Y**. This completes the low voltage control circuit, energizing the compressor, condenser fan motor and blower motor.

*NOTE - At the start of the each cooling demand, the combustion air blower (draft motor) will operate for 10 seconds.*

Unit compressors have internal protection. If there is an abnormal rise in the compressor temperature, the protector will open and the compressor will stop.

#### Blower Delay - Cooling

In the cooling mode, the circulating air blower operation is delayed for 5 seconds after the compressor starts. The blower continues to operate for 90 seconds after the compressor is de-energized.

*NOTE - With the proper thermostat and subbase, continuous blower operation is possible by closing the R to G circuit. Cooling blower delay is also functional in this mode.*

#### System Performance

This self-contained system has been factory-charged for optimal performance. If performance is questionable, use the following procedure to check the system.

Ensure that unit has been installed per these instructions and that line voltage and air flow are both correct. Check subcooling values by measuring pressure at the liquid line (high side) service port. Measure liquid line temperature within 2 inches of the service port connection to its main tube. If subcooling measured deviates from values in table 8 by more than 2 degrees F, check internal seals, service panels and duct system for air leaks, as well as restrictions. Also check blower speed settings. Make all necessary adjustments. If unit performance remains questionable, recover unit refrigerant charge, evacuate to 500 microns, and weigh in refrigerant to match value given on unit nameplate. It is critical that exact required charge is used. Failure to follow this instruction will compromise system performance. If unit performance is still questionable,

check for blocked coil or circuits, malfunctioning metering devices or other system component problems.

**Table 8. Liquid Subcooling Values**

Unit Model No.	Liquid Line Subcooling +/- 2 Deg. F @ ARI 82°F OD minus 80°F IDDB / 67°F IDWB
15GCSX-24	12°
15GCSX-30	12°
15GCSX-36	15°
15GCSX-42	10°
15GCSX-48	7°
15GCSX-60	8°

Verify system performance using table 7 as a general guide. Table 7 should not be used for charging unit. Minor variations in these pressures may be expected due to differences in installations. Significant differences could mean that the system is not properly charged or that a problem exists with some component in the system.

Used carefully, this table could serve as a useful service guide. Data is based on 80°F dry bulb / 67°F wet bulb return air. Allow unit operation to stabilize before taking pressure readings.

**Heating Start-Up**

**Pre-Start Check List:**

- 1 - Check the type of gas being supplied. Be sure it is the same as listed on the unit nameplate.
- 2 - Make sure the vent hood has been properly installed.

**FOR YOUR SAFETY READ BEFORE LIGHTING**

BEFORE LIGHTING smell all around the appliance area for gas. Be sure to smell around the base of the unit because some gas is heavier than air and will settle down low.

**! WARNING**

Electric shock hazard. Can cause injury or death. Do not use this unit if any part has been under water. Immediately call a qualified service technician to inspect the unit and to replace any part of the control system and any gas control which has been under water.

**! WARNING**

Danger of explosion. Can cause injury or product or property damage. If overheating occurs or if gas supply fails to shut off, shut off the manual gas valve to the appliance before shutting off electrical supply.

**! WARNING**

Electric shock hazard. Can cause injury or death. Before attempting to perform any service or maintenance, turn the electrical power to unit OFF at disconnect switch(es). Unit may have multiple power supplies.

**! WARNING**

Danger of explosion and fire. Can cause injury or product or property damage. You must follow these instructions exactly.

Use only your hand to turn the gas valve knob or move the switch. Never use tools. If the knob or switch will not move by hand, do not try to repair the gas valve. Call a qualified service technician. Force or attempted repair may result in a fire or explosion.

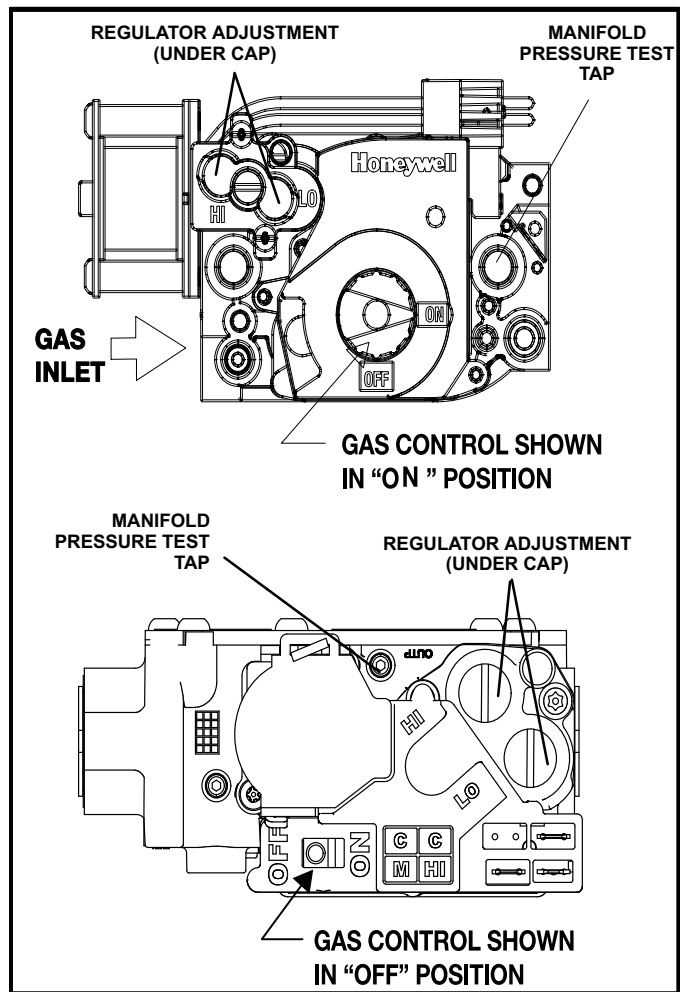

**Figure 12**

This furnace is equipped with a direct ignition control. Do not attempt to manually light the burners.

- 1 - Turn off electrical power to unit.
- 2 - Set thermostat to lowest setting.
- 3 - Turn the gas valve knob or move the switch to the ON position. Refer to figure 12.
- 4 - Turn on electrical power to unit.

- Set room thermostat to desired temperature. (If thermostat setpoint temperature is above room temperature after the pre-purge time expires, main burners will light).

### To Shut Down:

- Turn off electric power to unit.
- Turn the gas valve knob or move the switch to the OFF position.

### Post Start-up Check List (Gas)

After the control circuit has been energized and the heating section is operating, make the following checks:

- Use soap solution to check for gas leaks in the unit piping as well as the supply piping.
- Check for correct manifold gas pressures. See "Manifold Gas Pressure Adjustment."
- Check the supply gas pressure. It must be within the limits shown on rating nameplate. Supply pressure should be checked with all gas appliances in the building at full fire. At no time should the supply gas pressure exceed 10.5 inches w.c., nor drop below 5.0 inches w.c. for natural gas units. For propane gas, supply gas pressure should not drop below 11 inches w.c. If gas pressure is outside these limits, contact your gas supplier for corrective action.
- Adjust temperature rise to the range specified on the rating plate.

### Checking and Adjusting Gas Input

*NOTE - Units must be converted for use with LP/propane gas. Conversion kit is ordered separately. Conversion must be performed by an approved licensed pipe fitter or technician.*

The minimum permissible gas supply pressure is 5.0 inches W.C. for natural gas or 11.0 inches W.C. for LP/propane gas. The maximum inlet gas supply pressure is 10.5 inches W.C. for natural gas and 13.0 inches W.C. for LP/propane gas. Gas input must never exceed the input capacity shown on the rating plate.

Units fueled by natural gas are rated for manifold pressures of 2.0 inches W.C. for first stage and 3.5 inches W.C. for second stage.

Units fueled by LP/propane gas are rated for manifold pressures of 5.6 inches W.C. for first stage and 10.0 inches W.C. for second stage.

**Measure Manifold Pressure:** Shut off gas supply to the unit. Remove plug from pressure tap (see figure 12). Connect manometer or gauge to the proper pressure tap, then turn on the gas supply.

**Adjust Manifold Pressure:** The gas valve has separate adjusting screws for first stage (LO) and second stage (HI) (see figure 12). Turn the adjusting screws clockwise to increase pressure and input; turn counterclockwise to decrease pressure and input. The pressure regulator adjustment is sensitive. One turn of the adjusting screw results in a large change in manifold pressure.

Final first-stage and second-stage manifold pressures must be within the allowable ranges for the gas being used.

**For Natural Gas:** Check the furnace rate by observing gas meter, making sure all other gas appliances are turned off. The test hand on the meter should be timed for at least one revolution. Note the number of seconds for one revolution.

$$\text{BTU/HR} = \frac{\text{Cubic Feet Per Revolution}}{\text{INPUT No. Seconds Per Revolution}} \times 3600 \times \text{Heating Value}$$

The heating value of your gas can be obtained from your local utility.

**For LP/Propane Gas:** If a gas meter is available, check the input rate as described in the section above. Heating value of propane gas is available from propane supplier. Otherwise, the only check for the output rate is to properly adjust the manifold pressure using a manometer. Typical manifold setpoint for installations at altitudes from 0 to 4500 feet above sea level is 10.0 inches W.C.

### High Altitude Information

Units may be installed at altitudes up to 4500 feet (1372 m) above sea level without any modification. At altitudes above 4500 feet (1372 m), units must be de-rated as shown in table 9.

*NOTE - This is the only permissible derate for these units.*

**Table 9. Manifold Pressure Versus Altitude**

Altitude (ft.)	Natural Gas			Propane (LP)		
	Heating value* (BTU/ft <sup>3</sup> )	Manifold Pressure (in. w. c.)		Heating value* (BTU/ft <sup>3</sup> )	Manifold Pressure (in. w. c.)	
		High	Low		High	Low
2000	948	3.50	2.00	2278	10.00	5.60
3000	914	3.50	2.00	2196	10.00	5.60
4000	881	3.50	2.00	2116	10.00	5.60
4500	865	3.50	2.00	2077	10.00	5.60
5000	849	3.29	1.88	2039	9.41	5.38
5500	833	3.27	1.87	2000	9.35	5.34
6000	818	3.25	1.86	1964	9.29	5.31
6500	802	3.23	1.84	1927	9.24	5.28
7000	787	3.21	1.83	1891	9.18	5.25
7500	771	3.19	1.82	1853	9.12	5.21

\* Consult local utility for actual heating value.  
 Furnace input = Input Factor X Nameplate Input  
 Above 7500 feet, call Lennox Technical Services for additional assistance.

## Heating Sequence of Operation

When the thermostat calls for heating, W1 is energized.

*NOTE - The ignition control ignores a call for second-stage heat until first-stage heat has been established.*

The ignition control checks high temperature limit and roll out switches to make sure they are closed. The control then verifies that the pressure switch is open. If the pressure switch is closed, the control will flash code 3 on the LED and will wait indefinitely for the pressure switch to open. If the pressure switch is open, the control proceeds to the 15-second pre-purge.

The ignition control energizes the combustion air inducer on high speed, flashes a code 3 on the LED, and waits for the pressure switch to close.

When the pressure switch has closed, the LED code 3 flash stops and the control begins the 15-second pre-purge period. When the pre-purge time has expired, the control begins the ignition trial.

The ignition control energizes the gas valve and spark. The control ignores the flame sense signal for the first two seconds of the ignition trial. If the flame is established within 10 seconds, the control de-energizes the spark. If flame is not established within 10 seconds, the gas valve and spark are de-energized and the ignition control initiates a 30-second inter-purge sequence.

Approximately 30 seconds after the flame has been established, the circulating air blower starts and the combustion air inducer is switched to low speed. The ignition control inputs are continuously monitored to ensure that limit switch(es), roll out switch and pressure switch are all closed, and that the flame remains established and heating demand is present. First-stage gas valve, low-speed combustion air inducer and circulating blower remain energized. If the thermostat signals a requirement for second-stage heat **W2**, the ignition control initiates high heat operation.

When a signal for second stage heat is received by the ignition control, the control energizes the second-stage gas valve and high-speed combustion air inducer until the demand is satisfied.

If a first-stage heat demand continues after the second-stage heat demand has been satisfied, the ignition control immediately de-energizes the second-stage gas valve. The combustion air inducer is held in high speed operation for an additional 1 second after the second-stage gas valve is de-energized. First-stage heat operation (first-stage gas valve and low-speed combustion air inducer) continues until heating demand is satisfied.

When the heating demand is satisfied, the control immediately de-energizes the gas valve. The combustion air inducer remains energized for a 30-second post-purge period. The circulating air blower operates for 90 seconds after the gas valve is de-energized.

## Blower Delay - Heating

In the heating mode, the circulating air blower operation is delayed for 30 seconds after the flame is established. The blower continues to operate for 90 seconds after the gas valve is de-energized.

*NOTE - With the proper thermostat and subbase, continuous blower operation is possible by closing the **R** to **G** circuit.*

## Unit Controls

### Blower Control (A54)

15GCSX units are equipped with a variable speed motor which is controlled by a blower control. Blower control settings and operation are given on page 12.

### Ignition Control (A3)

The 15GCSX unit includes an ignition control which controls the combustion air inducer, gas valve and spark electrode. It receives signals from the main and auxiliary limit switches, the roll out switch, the pressure switch and the flame sensor. LED codes and flash rates are given on page 17. The ignition control is shown in figure 13.

### Ignition Control LED Codes

The ignition control LED flashes codes which indicate normal or abnormal operations:

**Slow Flash -- Normal operation, no call for heat.**  
One flash per second.

**Fast Flash -- Normal operation, call for heat.**  
Two flashes per second.

**Steady Off -- Internal failure or no power.**  
(Micro-controller failure; self-check.)

**Steady On -- Internal control failure.**  
(Micro-controller failure; self-check.)

**Code 2 -- System lockout -- Failed to detect or sustain flame or gas valve knob or switch off.**  
Two flashes in 1 second with a 1-second pause.

**Code 3 -- Pressure switch open with inducer on or closed with inducer off.**  
Three flashes in 1-1/2 seconds with a 1-second pause.

**Code 4 -- High limit /or rollout switch open.**  
Four flashes in 2 seconds with a 1-second pause.

**Code 5 -- Flame sensed while gas valve de-energized.**  
Five flashes in 2-1/2 seconds with a 1-second pause.

**Code 6 -- Roll out switch is open.**  
Six flashes in three seconds with a one-second pause.

## Ignition Control

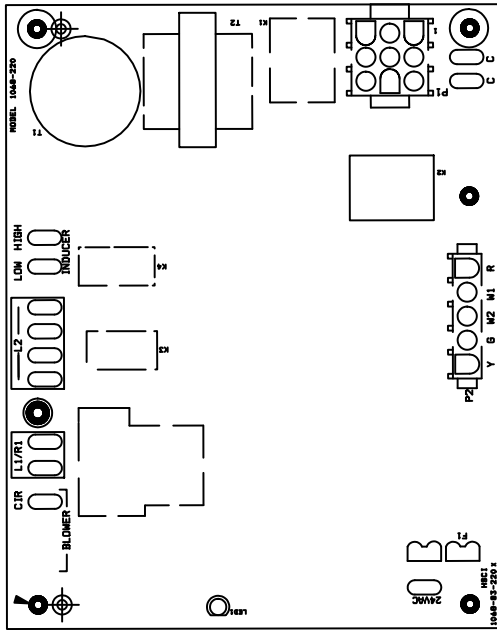

CONNECTOR P1  
 PIN 1 - LIMIT SWITCH (OUTPUT, COMMON WITH "W" TERMINAL)  
 PIN 2 - GAS VALVE 24 VAC COMMON (CHASSIS GROUND)  
 PIN 3 - LOW GAS VALVE OUTPUT  
 PIN 4 - LIMIT SWITCH INPUT  
 PIN 5 - PRESSURE SWITCH OUTPUT  
 PIN 6 - LOW PRESSURE SWITCH INPUT  
 PIN 7 - HIGH GAS VALVE OUTPUT  
 PIN 8 - HIGH PRESSURE SWITCH INPUT (OPTIONAL)  
 PIN 9 - FLAME SENSE INPUT

CONNECTOR P2  
 "R" - 24VAC TO THERMOSTAT  
 "W" - THERMOSTAT CALL FOR HEAT  
 "W2" - THERMOSTAT 2ND STAGE CALL FOR HEAT  
 "G" - THERMOSTAT CALL FOR CONTINUOUS FAN  
 "Y" - THERMOSTAT CALL FOR COOLING

### QUICK CONNECT TERMINALS

"INDUCER LOW" - DRAFT INDUCER MOTOR OUTPUT  
 "INDUCER HIGH" - 2ND STAGE DRAFT INDUCER MOTOR OUTPUT  
 "L1" (2) - 230 VAC LINE INPUT  
 "L2" (4) - 230 VAC LINE INPUT  
 "C" (2) - 24 VAC SYSTEM COMMON (GROUND)  
 "24VAC" - CONTINUOUS 24VAC FROM TRANSFORMER  
 "CIR" - CIRCULATING AIR BLOWER MOTOR

### TIMINGS:

PRE-PURGE:	15 SECONDS
IGNITION TRIAL	10 SECONDS
INTER-PURGE:	30 SECONDS
HEAT BLOWER ON DELAY	30 SECONDS
HEAT BLOWER OFF DELAY	90 SECONDS
POST PURGE	30 SECONDS
COOL FAN OFF DELAY	90 SECONDS

Figure 13

### Limit Control

This control is located inside the heating compartment and is designed to open at abnormally high air temperatures. It resets automatically. The limit switch operates when a high temperature condition, caused by inadequate blower supply airflow, occurs. The main gas valve is closed. The circulating air blower will continue to operate until the blower off delay period has elapsed.

### Pressure Switch

If the combustion air inducer motor should fail or if the vent system is blocked, the pressure switch prevents the gas valve from being energized.

### Spark Electrode and Flame Sensor Rod

The spark electrode and flame sensor rod are part of the burner assembly. The spark electrode is typically located on the far-left burner. The flame sensor rod is typically located on the far-right burner. If the ignition control does not receive a signal from the flame sensor indicating that the burners have established flame, the main gas valve will close after the 10-second ignition trial period built into the ignition control.

### Rollout Switch

The switch is located above the main burners. In the event of a sustained main burner rollout the main gas valve is closed. To reset, push the button on top of the switch.

### Auxiliary Limit (-42, -48 and -60 units only)

This control is located in the side of the circulating air blower housing. If the circulating air blower fails to operate, the temperature rises and opens the auxiliary limit. The main gas valve closes. This control resets automatically.

### Condenser Fan Clearances

The top of the condenser fan should be 1-1/2 inches from the bottom of the top grille. This dimension should be checked and the fan should be adjusted accordingly any time servicing of the outdoor fan system is required.

### Maintenance

The GCSX15 unit should be inspected annually by a qualified service technician to ensure proper operation.

### Filters

Not supplied. Inspect once a month. Replace disposable, or clean permanent-type, as necessary. DO NOT replace permanent type with disposable.

### Motors

Indoor, outdoor fan and vent motors are permanently lubricated and require no further lubrication. Motors should be cleaned yearly to prevent the accumulation of dust and dirt on the windings or motor exterior.

### Coil

Dirt and debris should not be allowed to accumulate on the coil surfaces or other parts in the air conditioning circuit. Cleaning should be performed as often as necessary. Use a brush, vacuum cleaner attachment, or other suitable means. If water is used to clean the coil, be sure the power to unit is shut off prior to cleaning.

*NOTE - Care should be used when cleaning the coil so that the coil fins are not damaged.*

Do not permit the hot condenser air discharge to be obstructed by overhanging structures or shrubs.

### To Clean Burners

Light the burners and allow unit to operate for a few minutes to establish normal burning conditions. Observe the burner flames. Compare this observation to figure 14 to

determine if flame is properly adjusted. Flame should be predominantly blue in color and strong in appearance. Verify that all burners are lit and that the flame does not impinge on the sides of the heat exchanger.

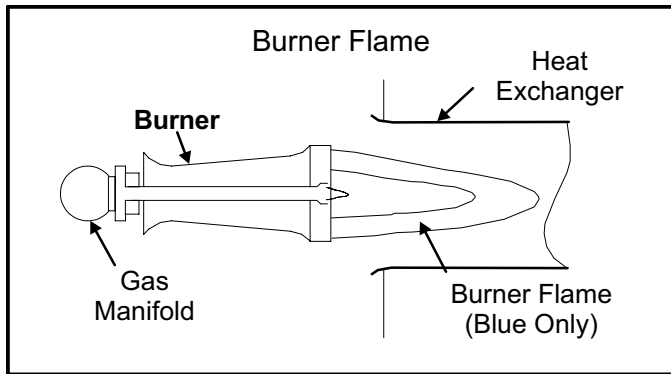

**Figure 14**

Distorted flame or yellow tipping of the natural gas flame (or long yellow tips on LP/propane flame) may be caused by one or more of the following: lint or dirt inside the burner or burner ports; lint or dirt at the air inlet between the burner and manifold pipe; or an obstruction over the burner orifice.

Use a soft brush or vacuum to clean the affected areas.

**Vent Outlet**

Visually inspect vent outlet periodically to make sure that there is no buildup of soot and dirt. If necessary, clean to maintain adequate opening to discharge flue products.

**Repair Parts and Accessories**

The following repair parts are available from your local dealer. When ordering parts, include the complete model number and serial number which are printed on the unit rating plate. All service must be performed by a licensed professional installer (or equivalent), service agency, or gas supplier.

**Controls**

- Rollout Switch
- Transformer
- Limit Control
- Gas Valve
- Ignition Control
- Electrode
- Flame Sensor
- Auxiliary Limit
- Pressure Switch
- Blower Control
- System Operations Monitor

**Blower Components**

- Blower Housing Assembly
- Blower Wheel
- Blower Motor
- Blower Motor Mount
- Blower Motor Capacitor (if used)
- Combustion Air Inducer
- Fan Blade
- Fan Motor
- Fan Motor Capacitor

**Heating Components**

- Gas Manifold
- Main Burner Orifices
- Main Burners
- Heat Exchanger

**Cooling Components**

- Compressor
- Evaporator Coil
- Drier
- Expansion Valve
- Contactors
- Capacitor
- Condenser Coil

**Planned Service**

You should expect a service technician to check the following items during an annual inspection. Power to the unit must be shut off for the service technician's safety.

- Fresh air grilles and louvers Must be open and unobstructed to provide combustion air.
- Burners must be inspected for rust, dirt, or signs of water.
- Exhaust pipe must be inspected for signs of water, damaged Rust or disconnected joints.
- Unit appearance must be inspected for rust, dirt, signs of water, burnt or damaged wires, or components. A good coat of auto wax can extend the appearance.
- Blower access door must be properly in place.
- Return air duct must be properly attached and provide an air seal to the unit.
- Operating performance — Unit must be observed during operation to monitor proper performance of the unit and the vent system.
- Combustion gases — Flue products must be analyzed and compared to the unit specifications.

Problems detected during the inspection may make it necessary to temporarily shut down the furnace until the items can be repaired or replaced.

Pay attention to your unit. Situations can arise between annual furnace inspections that may result in unsafe operation. For instance, items innocently stored next to the unit may obstruct the combustion air supply. This could cause incomplete combustion and the production of carbon monoxide gas.

Accessories	
Description	Lennox Catalog Number
LP/Propane Gas Conversion Kit (heat sizes 68 and 90)	92M52
LP/Propane Gas Conversion Kit (heat sizes 83, 110 and 138)	92M56
Filter Kit (2-ton to 3-ton capacity units)	92M54
Filter Kit (3-1/2-ton to 5-ton capacity units)	92M55
PCO20-28	X8787
Installation Hardware Kit for PCO20-28	Y0629