



© 2012 Lennox Industries Inc.
P.O. Box 799900
Dallas, Texas, USA

GAS UNITS KITS AND ACCESSORIES

TP Technical
Publications
Litho U.S.A.

507059-01
06/2012

REPLACEMENT COLD END COLLECTOR BOX

INSTALLATION INSTRUCTIONS FOR REPLACEMENT COLD END COLLECTOR BOX KIT 92W30 USED ON G71MPP-070 SERIES UNITS

Field Provided Tools & Materials

1/4 inch and 5/16 inch nut drivers
Knife or scissors for cutting tubing

Shipping & Packing List

Package 1 of 1 contains:

- 1- Replacement cold end collector box
- 2- 4" long 3/8" diameter hoses
- 2- 1/4" x 3/8" barbed reduction couplers
- 2- Wire ties
- 8- Screws

Shipping Damage

Check equipment for shipping damage. If you find any damage, immediately contact the last carrier.

General

These instructions are intended as a general guide and do not supersede local codes in any way.

Application

Use kit 92W30 to replace the cold end collector box in G71MPP-070-01, -02 and -03 units.

Installation

- 1 - Turn off gas supply and electrical power to the unit.
- 2 - Remove vestibule access panel.
- 3 - Remove pressure switches from combustion air inducer (CAI) and set aside. Save screws. Label pressure switch hoses for re-assembly.
- 4 - Loosen clamp attaching blower to rubber no-hub connector.
- 5 - Remove CAI from the collector box. Save screws for re-assembly.

WARNING

The plumbing configuration of the newly installed cold box must match the plumbing configuration before change out. Failure to do so may result in water damage and/or flue products entering the living space.

- 6 - Note orientation of collector box and check orifice size located next to label on box. Match the orifice size with replacement collector box orifice size.
- 7 - Disconnect the (4) condensate tubes positioned at each corner of the collector box.
- 8 - Disconnect pressure switch hoses from collector box. Label each hose (+ or -) depending on which port it came from.
- 9 - Remove and discard the (8) screws holding the collector box and remove box from the unit.
- 10 - Remove any gasket residue left on the vestibule panel or on the back of the CAI to ensure leak tight connections when reassembled.
- 11 - Use the provided (8) screws and install the replacement collector box. Make note of correct orientation.
- 12 - Reattach condensate hoses to the collector box.
- 13 - Insert end of CAI into no-hub connector, making sure the clamp is in its proper position and use the existing screws to re-install the CAI to the collector box.
- 14 - Position and tighten no-hub clamp.
- 15 - Use the existing screws and re-install pressure switches to CAI.
- 16 - Reconnect existing positive (+) port pressure switch hoses to the same (+) ports on the collector box.
- 17 - Insert the provided barbed reduction couplers into each of the (2) provided 3/8" ID hoses then connect to the 3/8" negative (-) ports on the box. Make sure the hoses are fully engaged to the ports. See figure 1.
- 18 - Route the 3/8" hose in an upward direction to avoid any condensate collecting in the hose which will affect the pressure switch set points. The barb connector end of the hose must be above the top of the collector box port.



19 -Cut the existing original hose attached to the pressure switch to a length that gives the best routing from the connecting barb to the pressure switch. If it better suits the routing, the 3/8" hose may also be cut. However, the remaining length of 3/8" hose must be at least 2 1/2" long to ensure proper engagement of the connecting barb and the collector box port. In some cases the pressure switch barbs are below the port on the collector box. In those cases the connecting hoses should be looped up to prevent condensate collection in the

hose before the hose is dropped down to the pressure switch. Two wire ties are provided, if needed to properly position the hoses as directed.

20 -Recheck all hose connections for proper fit and engagement.

21 -Return gas supply and electrical power to furnace.

22 -Follow Start-Up procedure found on the unit access panel or in the unit installation instructions.

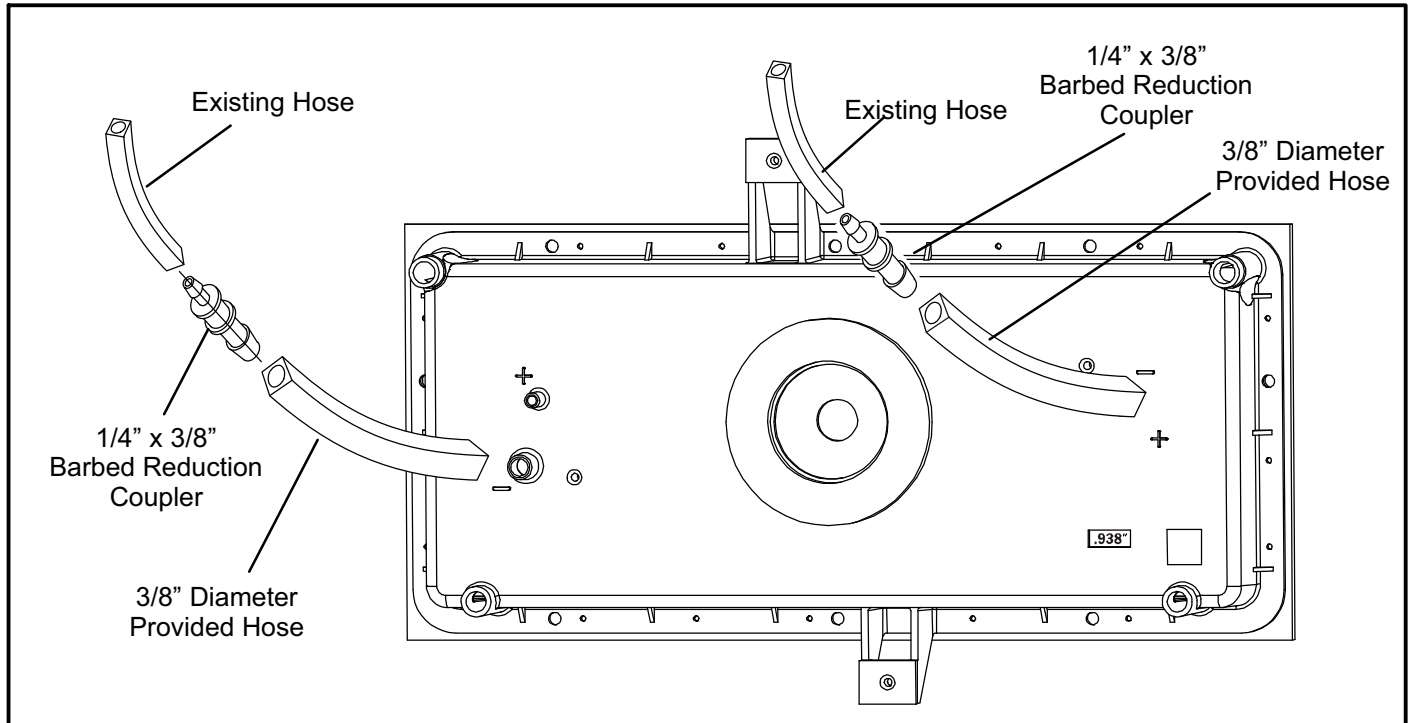

FIGURE 1