

**INSTALLATION INSTRUCTIONS FOR CRANKCASE HEATER KIT
 USED ON ZG/ZC 036, 048, 060 PACKAGED UNITS**

Shipping and Packing List

Package 1 of 1 contains:

- 1- Crankcase heaters
- 1- Wire harness

Bag assembly containing:

- 1-Web bushing
- 1-Washer
- 1-Screw

Check packaging for shipping damage. Contact the last carrier immediately if any shipping damage is found.

Application

The crankcase heater prevents refrigerant from migrating to the compressor, condensing and mixing with oil when the unit is off.

Crankcase heaters are used as follows:

Unit	Voltage	Kit	
036, 048	208/230	99W61	610195-01
036, 048	460/380	99W62	610195-02
036, 048	575	99W63	610195-03
060	208/230	99W64	610195-04
060	460/380	99W65	610195-05
060	575	99W66	610195-06

⚠ WARNING

Improper installation, adjustment, alteration, service or maintenance can cause property damage, personal injury or loss of life. Installation and service must be performed by a qualified installer, service agency or the gas supplier

⚠ IMPORTANT

Power wiring must be routed and secured away from hot copper piping to avoid melting wiring insulation.

Installation

- 1- Disconnect all power to unit and open compressor access panel.
- 2- Position crankcase heater below dimples on compressors as shown in figure 1. Position belly-band screw over the vertical weld seam on the compressor. Tighten belly-band screw to secure in place.

Note - Tightening the belly-band screw over the compressor seam prevents damage to the heater wire.

- 3- Remove the knockout located in the outdoor coil support. See figure 2. Insert the web bushing that is included in the bag assembly.
- 4- Route harness to control box as shown in figure 2.
- 5- Use markings on wires to connect harness as shown in figure 3. Also refer to unit wiring diagram.
- 6- Secure crankcase heater ground wires using screw and washer provided in kit. See figure 4.

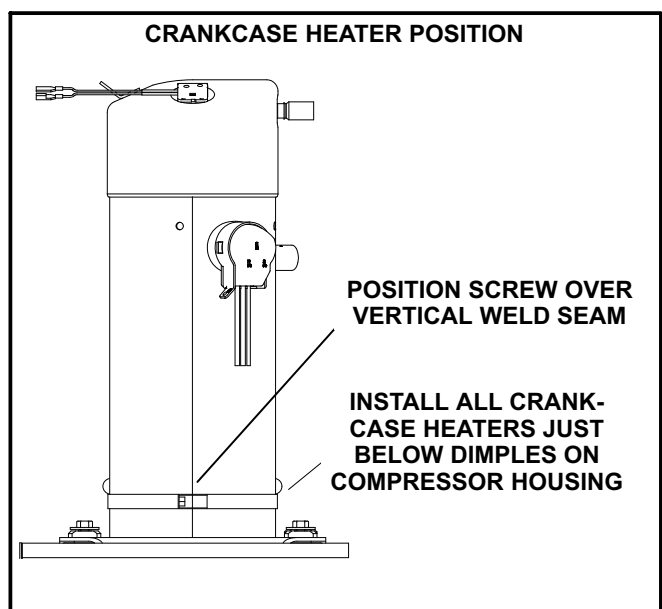

FIGURE 1

WIRE ROUTING

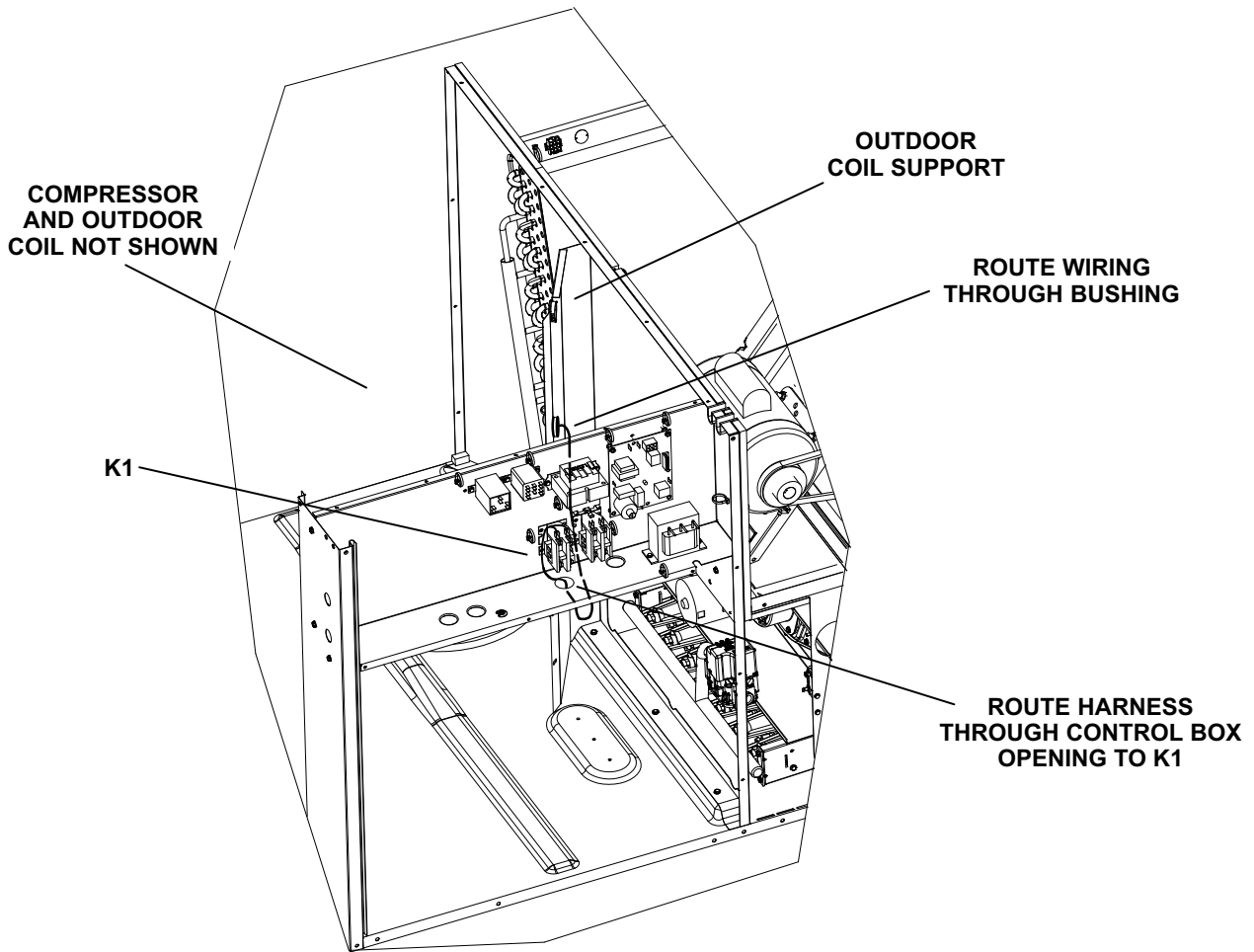
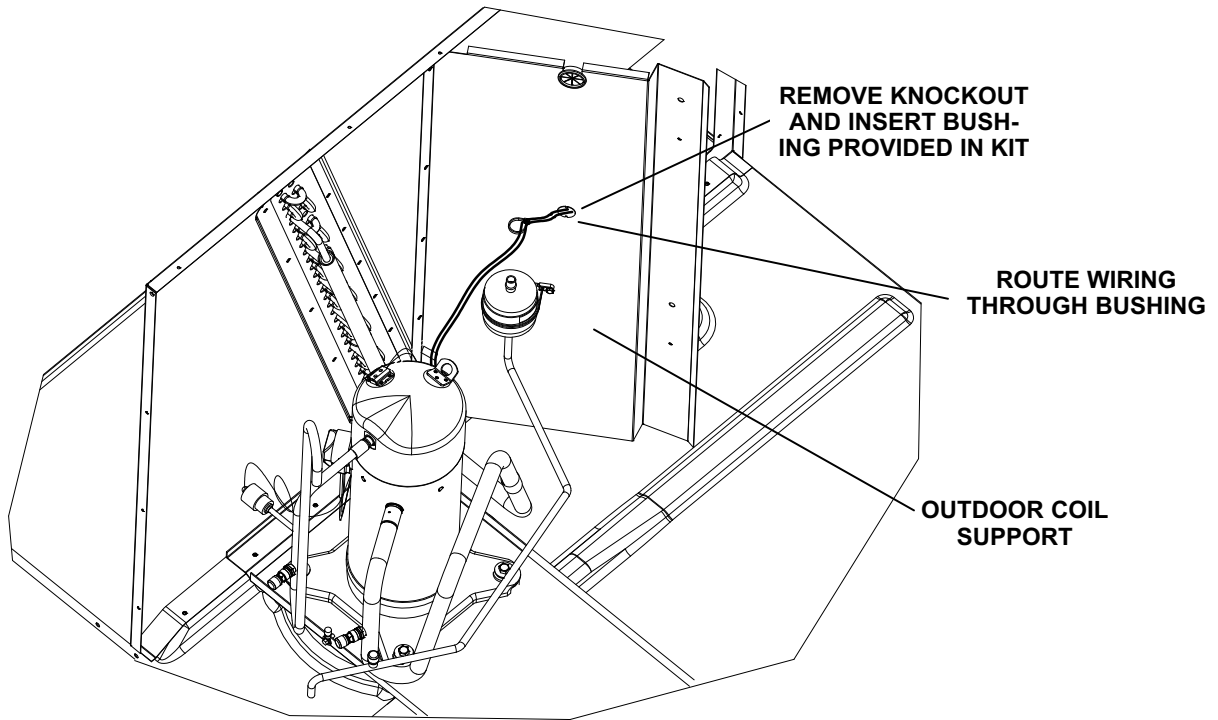

FIGURE 2

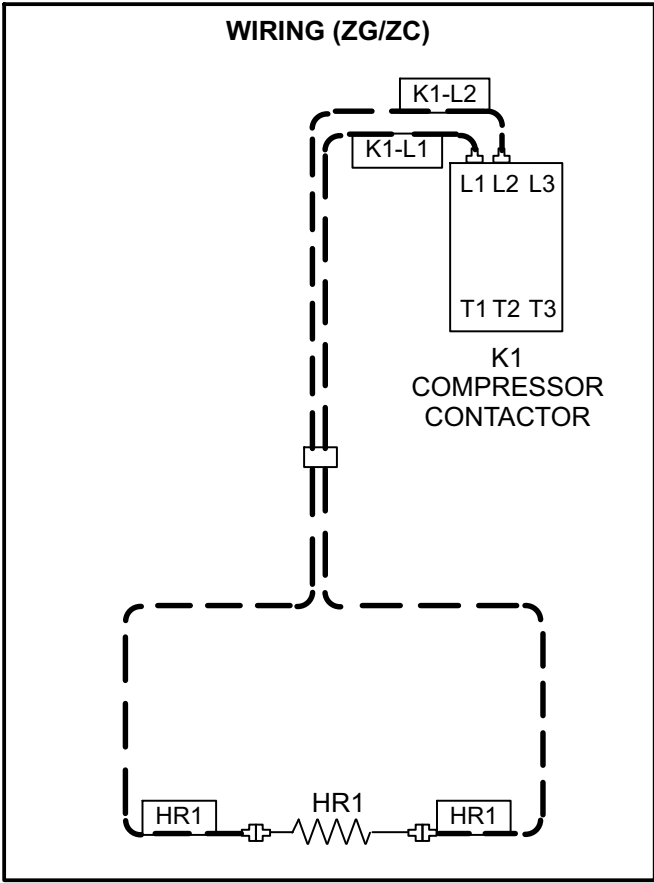

FIGURE 3

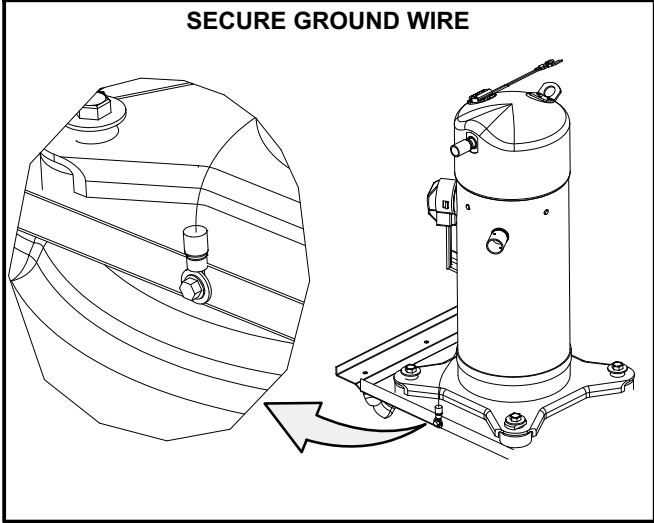

FIGURE 4