

INSTALLATION INSTRUCTIONS

⚠ WARNING

Improper installation, adjustment, alteration, service or maintenance can cause property damage, personal injury or loss of life. Installation and service must be performed by a licensed professional HVAC installer or equivalent or service agency.

⚠ CAUTION

Danger of sharp metallic edges. Can cause injury. Take care and wear protective clothing when servicing unit to avoid accidental contact with sharp edges.

RETAIN THESE INSTRUCTIONS FOR FUTURE REFERENCE

ZHA036 (3 TON)
ZHB036 (3 TON)
ZHA048 (4 TON)
ZHB048 (4 TON)
ZHA060 (5 TON)
ZHB060 (5 TON)

HEAT PUMP PACKAGED UNITS
 507111-02
 2/2015
 Supersedes 507111-01

Table Of Contents

Dimensions	Page 2
Shipping and Packing List	Page 3
General	Page 3
Requirements	Page 3
Unit Support	Page 4
Duct Connection	Page 4

Rigging Unit For Lifting	Page 4
Horizontal Air Discharge	Page 5
Condensate Drains	Page 5
Electrical Connections	Page 6
Blower Operation and Adjustments	Page 7
Start-Up	Page 16
Defrost Control Board	Page 22
Service	Page 23

ZH 036, 048, 060 PARTS ARRANGEMENT

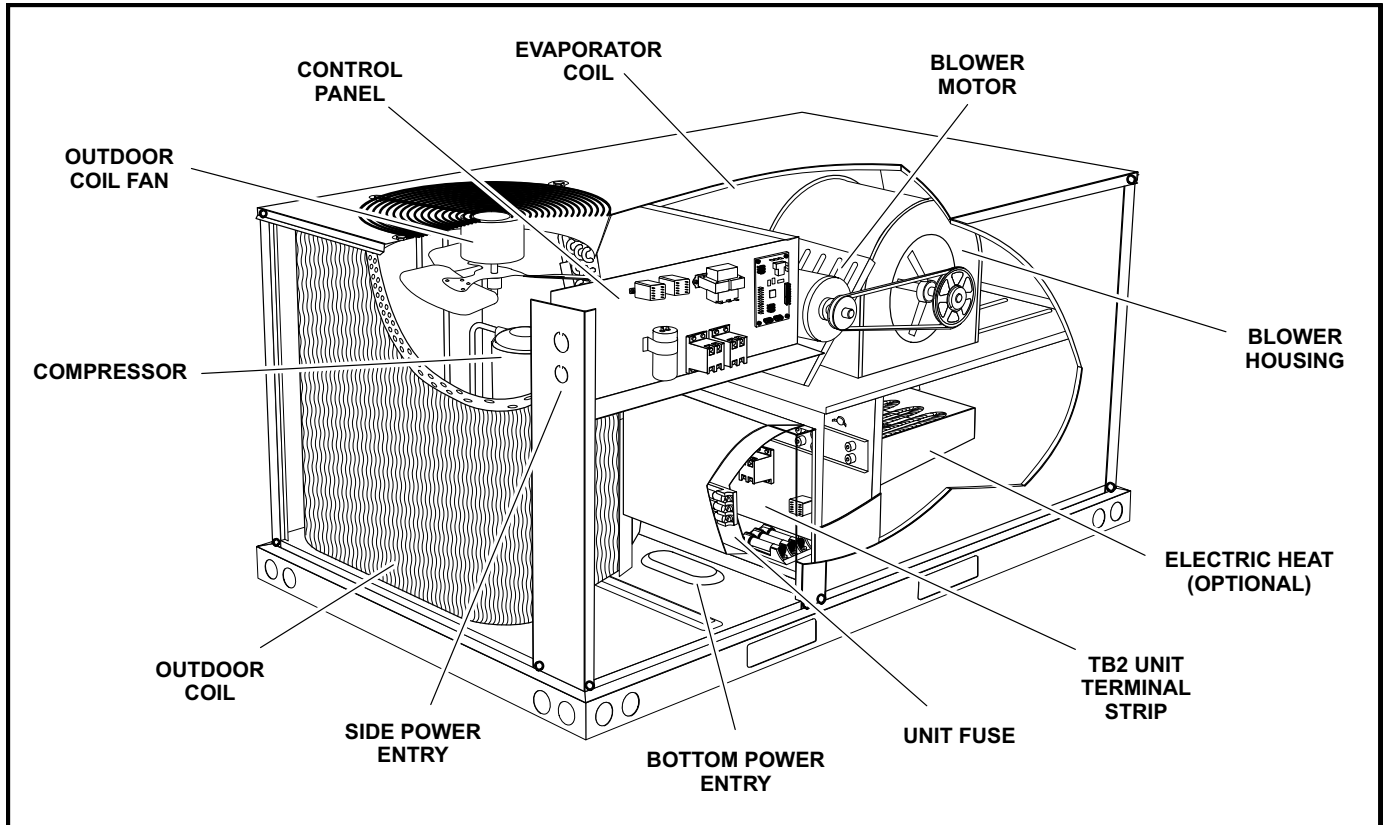

ZH 036, 048, 060, DIMENSIONS in (mm)

BOTTOM POWER ENTRY

Holes required for Optional Bottom Power Entry Kit

	Threaded Conduit Fittings (Provided in Kit)	Wire Use	Hole Diameter Required in Unit Base (Max.)
A	1/2	ACC.	7/8 (23)
B	1/2	24V	7/8 (23)
C	3/4	POWER	1-1/8 (29)

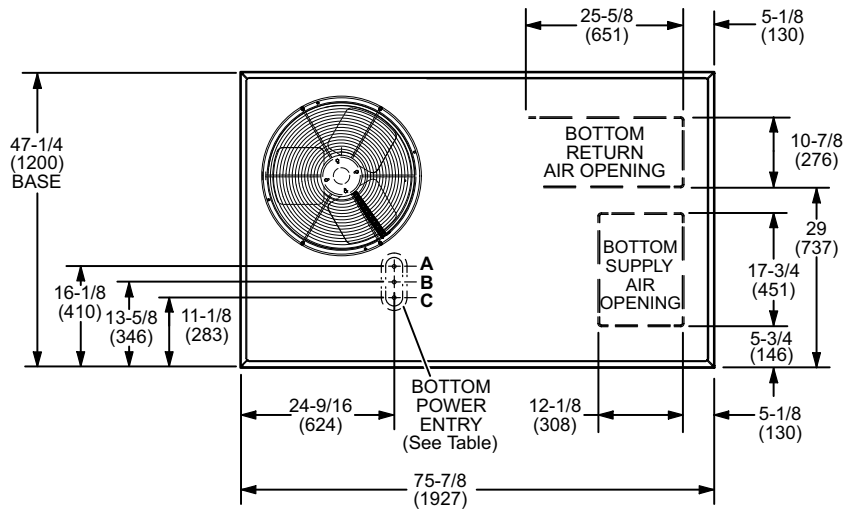

TOP VIEW (Base)

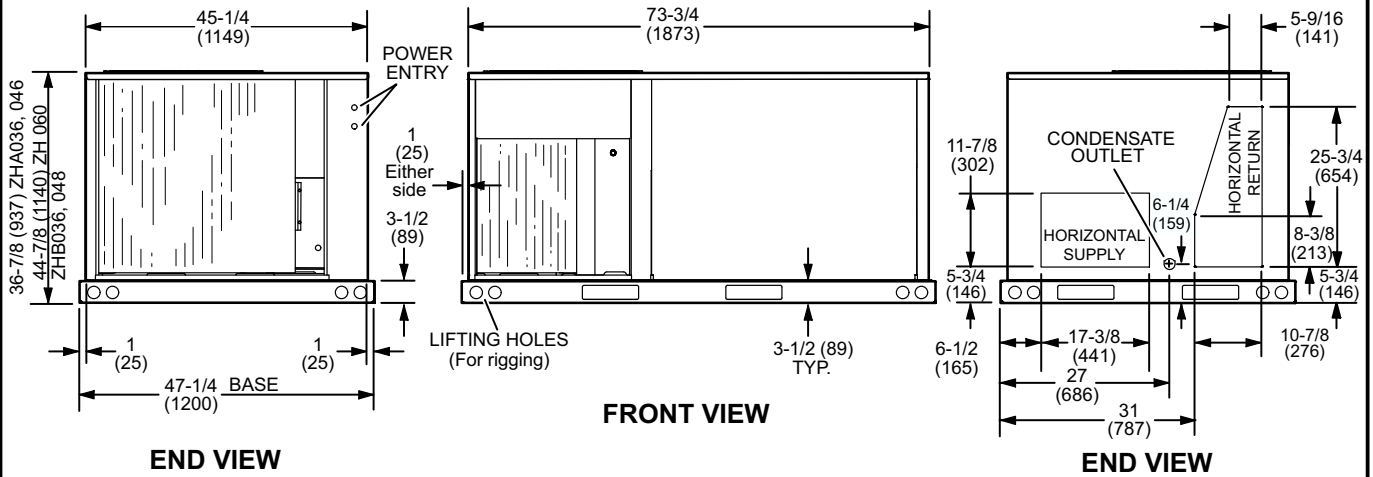

END VIEW

FRONT VIEW

END VIEW

Shipping and Packing List

Package 1 of 1 contains:

1 - Assembled unit

Check unit for shipping damage. Receiving party should contact last carrier immediately if shipping damage is found.

General

These instructions are intended as a general guide and do not supersede local codes in any way. Authorities having jurisdiction should be consulted before installation.

Availability of units and options varies by brand.

Requirements

The ZH unit is CSA certified as a heat pump with cooling and with or without auxiliary electric heat for non-residential use only at the clearances to combustible materials as listed on the unit nameplate and in figure 1.

Installation of ZH heat pumps must conform with standards in National Fire Protection Association (NFPA) "Standard for Installation of Air Conditioning and Ventilating Systems NFPA No. 90A," "Standard for Installation of Residence Type Warm Air Heating and Air conditioning Systems NFPA No. 90B," local municipal building codes and manufacturer's installation instructions.

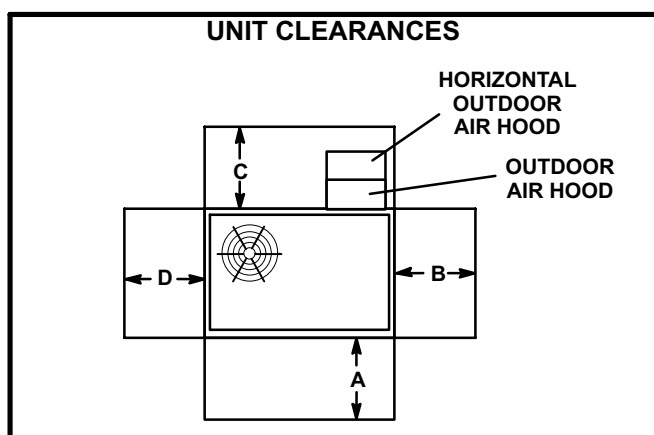

FIGURE 1

¹ Unit Clearance	A in.(mm)	B in.(mm)	C in.(mm)	D in.(mm)	Top Clearance
Service Clearance	36 (914)	36 (914)	36* (914)	36 (914)	Unob- structed
Minimum Operation Clearance	36 (914)	36 (914)	36* (914)	36 (914)	Unob- structed

*Clearance is 60 in. (1524mm) in horizontal air flow applications.

Note - Entire perimeter of unit base requires support when elevated above mounting surface.

¹ **Service Clearance** - Required for removal of serviceable parts.

Minimum Operation Clearance - Required clearance for proper unit operation.

⚠ NOTICE

Roof Damage!

This system contains both refrigerant and oil. Some rubber roofing material may absorb oil, causing the rubber to swell. Bubbles in the rubber roofing material can cause leaks. Protect the roof surface to avoid exposure to refrigerant and oil during service and installation. Failure to follow this notice could result in damage to roof surface.

The National Electric Code (ANSI/NFPA No. 70-1984) is available from:

National Fire Protection Association
1 Batterymarch Park
PO Box 9101
Quincy, MA 02269-9101

Installation of CSA certified units must also conform with current standard C273.5 "Installation Requirements for Heat Pumps" and applicable local codes. Authorities having jurisdiction should be consulted before installation.

Use of this unit as a construction heater or air conditioner is not recommended during any phase of construction. Very low return air temperatures, harmful vapors and operation of the unit with clogged or misplaced filters will damage the unit.

If this unit has been used for heating or cooling of buildings or structures under construction, the following conditions must be met or the warranty will be void:

- A room thermostat must control the unit. The use of fixed jumpers that will provide continuous heating or cooling is not allowed.
- A pre-filter must be installed at the entry to the return air duct.
- The return air duct must be provided and sealed to the unit.
- Return air temperature range between 55°F (13°C) and 80°F (27°C) must be maintained.
- Air filters must be replaced and pre-filter must be removed upon construction completion.
- The unit components, duct system, air filters and evaporator coil must be thoroughly cleaned following final construction clean-up.
- The unit operating conditions (including airflow, cooling operation, and heating operation) must be verified according to these installation instructions.

⚠ WARNING



Electric shock hazard and danger of explosion. Can cause injury, death or product or property damage. Turn off electrical power to unit before performing any maintenance or servicing operations on the unit.

⚠ IMPORTANT

The Clean Air Act of 1990 bans the intentional venting of refrigerant (CFC's and HCFC's) as of July 1, 1992. Approved methods of recovery, recycling or reclaiming must be followed. Fines and/or incarceration may be levied for non-compliance.

Unit Support

NOTE - Securely fasten roof frame to roof per local codes.

ZH 036, 048, 060 units are installed on Z1CURB frames.

A - Downflow Discharge Application

Roof Mounting with Z1CURB

- 1- The Z1CURB roof mounting frame must be installed, flashed and sealed in accordance with the instructions provided with the frame.
- 2- The Z1CURB roof mounting frame should be square and level to 1/16" per linear foot (5mm per linear meter) in any direction.
- 3- Duct must be attached to the roof mounting frame and not to the unit; supply and return plenums must be installed before setting the unit.

Installer's Roof Mounting Frame

Many types of roof frames can be used to install the unit, depending upon different roof structures. Items to keep in mind when using the building frame or supports are:

- 1- The unit base is fully enclosed and not insulated, so an enclosed, insulated frame is required.
- 2- The frames or supports must be constructed with non-combustible materials and should be square and level to 1/16" per linear foot (5mm per linear meter) in any direction.
- 3- Frame or supports must be high enough to prevent any form of moisture from entering unit. Recommended minimum frame height is 14" (356mm).
- 4- Duct must be attached to the roof mounting frame and not to the unit. Supply and return plenums must be installed before setting the unit.
- 5- Units require support along all four sides of unit base. Supports must be constructed of steel or suitably treated wood materials.

NOTE-When installing unit on a combustible surface for downflow discharge applications, the Z1CURB roof mounting frame is required.

B - Horizontal Discharge Applications

- 1- Specified installation clearances must be maintained when installing units. Refer to figure 1.
- 2- Top of support slab should be at least 4" (102mm) above the finished grade and located so no run-off water from higher ground can collect around the unit.
- 3- Units require support along all four sides of unit base. Supports must be constructed of steel or suitably treated wood materials.

Duct Connection

All exterior ducts, joints, and openings in roof or building walls must be insulated and weatherproofed with flashing and sealing compounds in accordance with applicable codes. Any duct passing through an unconditioned space must be insulated.

⚠ CAUTION

In downflow applications, do not drill or punch holes in base of unit. Leaking in roof may occur if unit base is punctured.

Rigging Unit For Lifting

- 1- Connect rigging to the unit base using both holes in each corner. See figure 2.
- 2- All panels must be in place for rigging.
- 3- Place field-provided H-style pick in place just above top edge of unit. Frame must be of adequate strength and length. (H-style pick prevents damage to unit.)

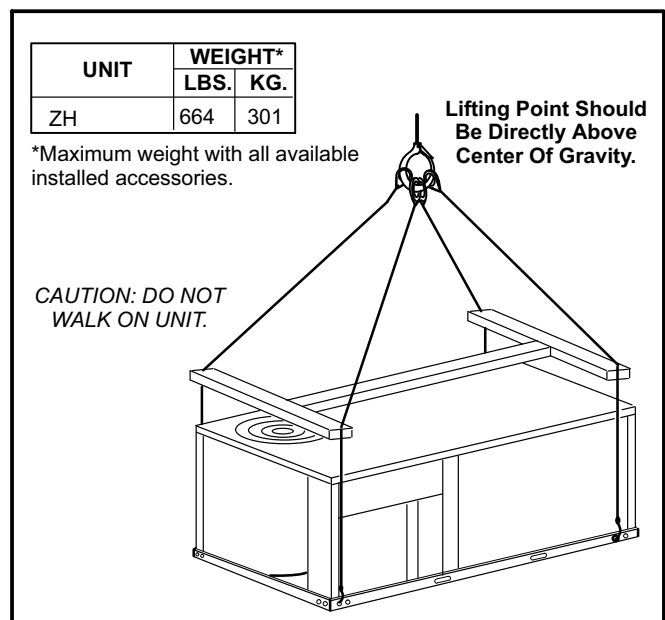

FIGURE 2

Horizontal Air Discharge

Unit is shipped with panels covering the horizontal supply and return air openings. See figure 3.

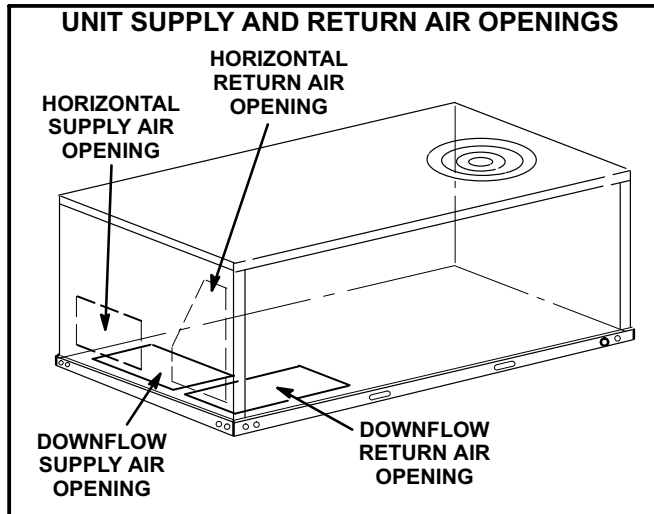

FIGURE 3

- 1- Remove horizontal covers and place a bead of silicone sealant on the underside of the duct cover flanges. See figure 4.
- 2- Position covers over downflow openings. Secure covers with self-drilling screws in at least two places on each cover. Drill through duct cover side into flange of base pan.
- 3- Place a bead of silicone between insulation and duct cover to seal in insulation edges. Let silicone dry before running gas or electric heat.

Units Equipped With An Optional Horizontal Economizer

- 1- Install the horizontal supply air cover over the down flow supply air opening as described above.
- 2- Leave the horizontal return air cover in place.
- 3- Locate the extra horizontal return cover that is included with the horizontal economizer kit. Install as described in previous section.

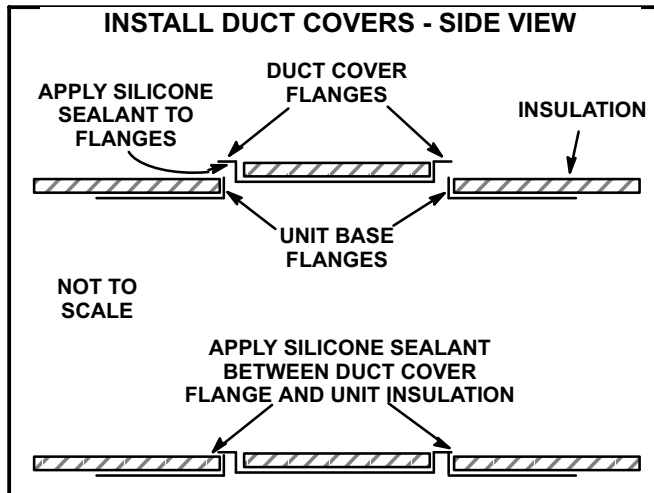

FIGURE 4

- 4- Install return air duct on the intake air side of the horizontal economizer. See figure 5.
- 5- Horizontal economizer and return air duct must be field-supported.

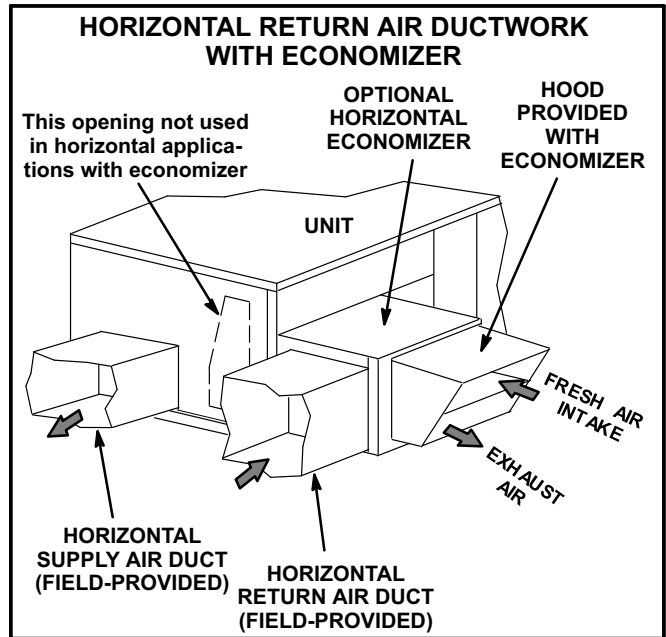

FIGURE 5

Condensate Drains

Make drain connection to the drain coupling provided on unit.

Note - The drain pan is made with a glass reinforced engineered plastic capable of withstanding typical joint torque but can be damaged with excessive force. Tighten pipe nipple hand tight and turn an additional quarter turn.

A trap must be installed between drain connection and an open vent for proper condensate removal. See figure 6. It is sometimes acceptable to drain condensate onto the roof or grade; however, a tee should be fitted to the trap to direct condensate downward. The condensate line must be vented. Check local codes concerning condensate disposal. Refer to pages 1 and 2 for condensate drain location.

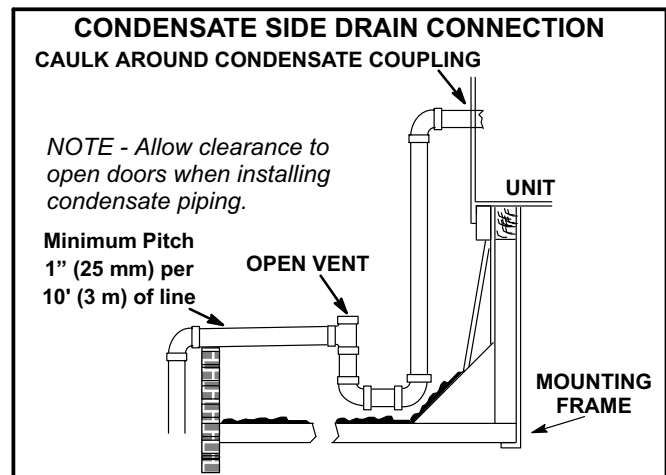

FIGURE 6

Electrical Connections

POWER SUPPLY

Do not apply power or close disconnect switch until installation is complete. Refer to start-up directions. Refer closely to unit wiring diagram.

Refer to unit nameplate for minimum circuit ampacity and maximum fuse size.

- Units are factory-wired for 240, 460, or 575 volt supply. **For 208V supply**, remove the insulated terminal cover from the 208V terminal on the control transformer. Move the wire from the transformer 240V terminal to the 208V terminal. Place the insulated terminal cover on the unused 240V terminal.
- Route power through the side or bottom power entry area. For bottom power entry, a bottom power entry kit must be used. Connect power wiring to K1/K3 contactors in control box. See figure 7. On units equipped with electric heat, route power wiring to TB2; see parts arrangement for location. See unit wiring diagram.

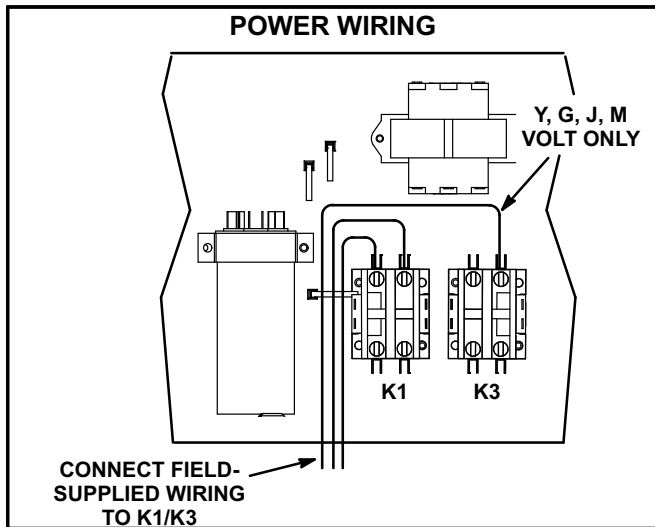

FIGURE 7

CONTROL WIRING

A - Thermostat Location

Room thermostat mounts vertically on a standard 2" X 4" handy box or on any non-conductive flat surface.

Locate thermostat approximately 5 feet (1524 mm) above the floor in an area with good air circulation at average temperature. Avoid locating the room thermostat where it might be affected by:

- drafts or dead spots behind doors and in corners
- hot or cold air from ducts
- radiant heat from sun or appliances
- concealed pipes and chimneys

IMPORTANT - Unless field thermostat wires are rated for maximum unit voltage, they must be routed away from line voltage wiring.

B - Control Wiring

- Route thermostat cable or wires from subbase to control panel (refer to unit dimensions to locate bottom and side power entry).

Use 18 AWG wire for all applications using remotely installed electro-mechanical and electronic thermostats.

- Install thermostat assembly in accordance with instructions provided with thermostat.
- Connect thermostat wiring to low voltage leads in control box. Wire as shown in figure 8 for electro-mechanical and electronic thermostats. If using other temperature control devices or energy management systems see instructions and wiring diagram provided by manufacturer.

IMPORTANT-Terminal connections at the wall plate or subbase must be made securely. Loose control wire connections may allow unit to operate but not with proper response to room demand.

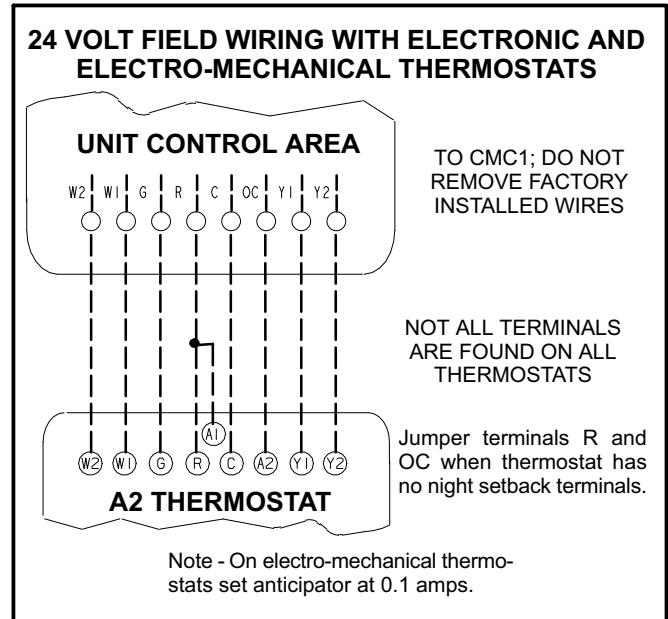

FIGURE 8

Blower Operation and Adjustments

Units are equipped with belt drive blowers; available drive varies by model.

⚠️ IMPORTANT

Three phase scroll compressors must be phased sequentially for correct compressor and blower rotation. Follow "COOLING START-UP" section of installation instructions to ensure proper compressor and blower operation.

A - Blower Operation

Initiate blower demand at thermostat according to instructions provided with thermostat. Unit will cycle on thermostat demand. The following steps apply to applications using a typical electro-mechanical thermostat.

- 1- Set thermostat or temperature control device fan switch to **AUTO** or **ON**. With fan switch in **ON** position, blower will operate continuously. With fan switch in **AUTO** position, the blower will cycle with demand.
- 2- Blower and entire unit will be off when thermostat or temperature control device system switch is in **OFF** position.

B - Determining Unit CFM

- 1- The following measurements must be made with air filters in place.
- 2- With all access panels in place, measure static pressure external to unit (from supply to return).

Blower performance data is based on static pressure readings taken in locations shown in figure 9.

Note - Static pressure readings can vary if not taken where shown.

- 3- Measure the indoor blower wheel RPM.
- 4- Referring to pages 9-14, use static pressure and RPM readings to determine unit CFM. Use option/accessory air resistance table on page 15 when installing units with any of the options or accessories listed. Refer to table 3 for minimum airflow when electric heat is installed.
- 5- The blower RPM can be adjusted at the motor pulley. Loosen Allen screw and turn adjustable pulley clockwise to increase CFM. Turn counterclockwise to decrease CFM. See figure 10. Do not exceed minimum and maximum number of pulley turns as shown in table 1.

**TABLE 1
MINIMUM AND MAXIMUM PULLEY ADJUSTMENT**

Belt	Min. Turns Open	Maxi. Turns Open
A Section	No minimum	5

C - Blower Belt Adjustment

Maximum life and wear can be obtained from belts only if proper pulley alignment and belt tension are maintained. Tension new belts after a 24-48 hour period of operation. This will allow belt to stretch and seat grooves. Make sure blower and motor pulley are aligned as shown in figure 11.

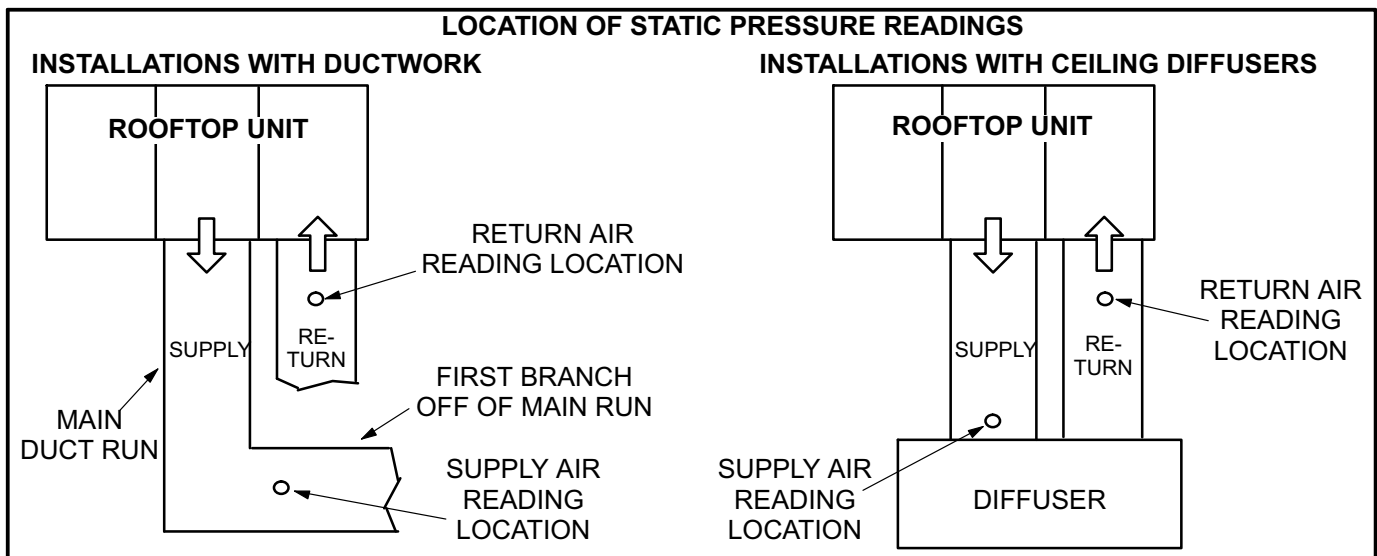

FIGURE 9

BLOWER ASSEMBLY

TO INCREASE BELT TENSION

- 1-Loosen four bolts securing motor base to mounting frame.
- 2-Slide the motor downward to tighten the belt.
- 3-Tighten four bolts on motor base.

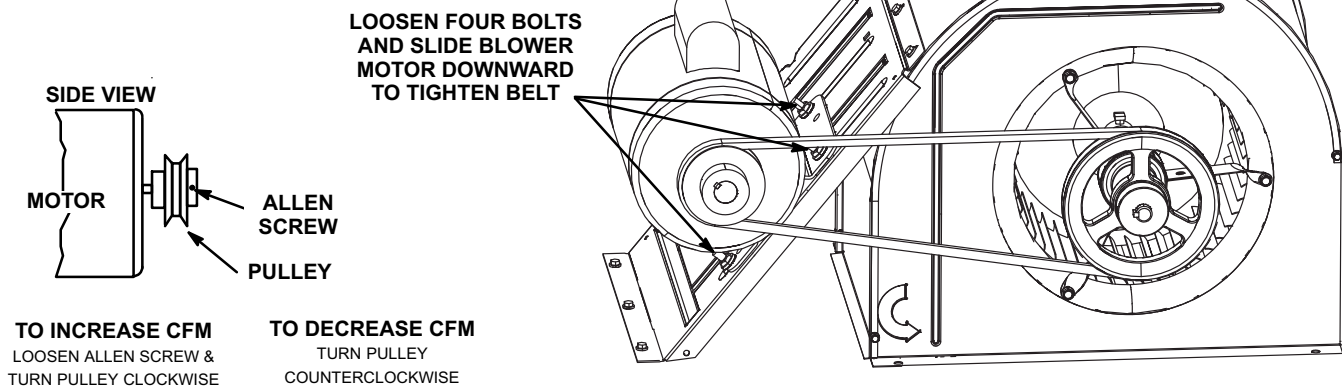

FIGURE 10

PULLEY ALIGNMENT

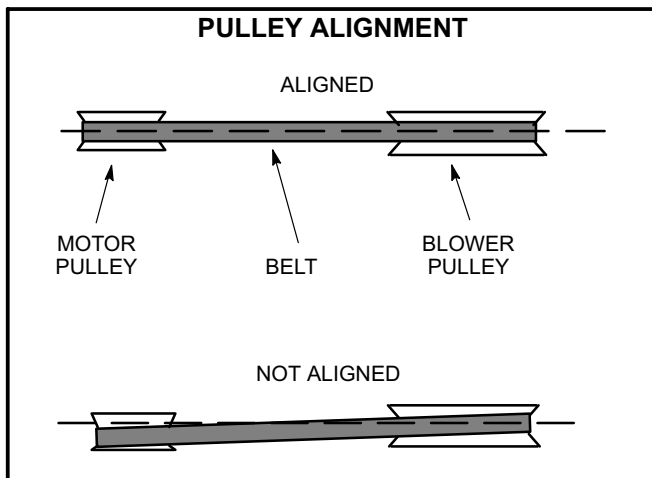

FIGURE 11

- 1- Loosen four bolts securing motor base to mounting frame. See figure 10.

2- To increase belt tension -

Slide blower motor downward to tighten the belt. This increases the distance between the blower motor and the blower housing.

To loosen belt tension -

Slide blower motor upward to loosen the belt. This decreases the distance between the blower motor and the blower housing.

- 3- Tighten four bolts securing motor base to the mounting frame.

D - Check Belt Tension

Overtensioning belts shortens belt and bearing life. Check belt tension as follows:

- 1- Measure span length X. See figure 12.

- 2- Apply perpendicular force to center of span (X) with enough pressure to deflect belt 1/64" for every inch of span length or 1.5mm per 100mm of span length.

Example: Deflection distance of a 40" span would be 40/64" or 5/8".

Example: Deflection distance of a 400mm span would be 6mm.

- 3- Measure belt deflection force. For a used belt, the deflection force should be 5 lbs. (35kPa). A new belt deflection force should be 7 lbs. (48kPa).

A force below these values indicates an undertensioned belt. A force above these values indicates an overtensioned belt.

MEASURE BELT TENSION

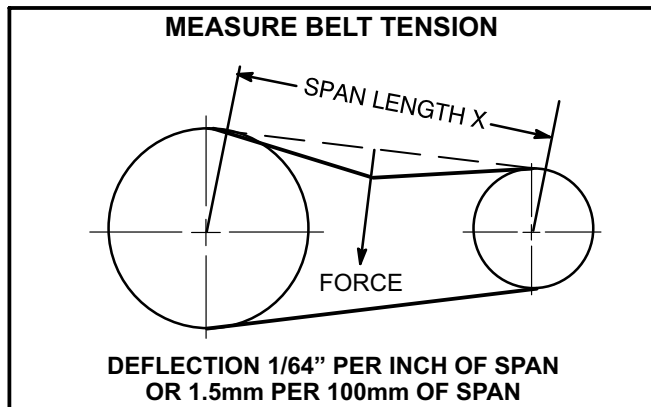

FIGURE 12

E-Field-Furnished Blower Drives

For field-furnished blower drives, use pages 9-14 to determine BHP and RPM required. Reference page 15 for additional air resistance and drive kit numbers. See table 2 for drive component manufacturer's numbers.

BLOWER DATA - BELT DRIVE - ZHA036

BLOWER TABLE INCLUDES RESISTANCE FOR BASE UNIT ONLY WITH DRY INDOOR COIL AND AIR FILTERS IN PLACE.

FOR ALL UNITS ADD:

1 - Any factory installed options air resistance (heat section, economizer, wet coil, etc.).

2 - Any field installed accessories air resistance (duct resistance, diffuser, etc.).

See page 15 for blower motors and drives and wet coil and options/accessory air resistance data.

DOWNFLOW

Air Volume cfm	External Static - in. w.g.															
	0.10		0.20		0.30		0.40		0.50		0.60		0.70		0.80	
	RPM	BHP	RPM	BHP	RPM	BHP	RPM	BHP	RPM	BHP	RPM	BHP	RPM	BHP	RPM	BHP
	Field Furnished				Kit ZA01											
900	562	0.16	629	0.18	699	0.19	771	0.2	840	0.22	904	0.24	962	0.26	1015	0.29
1000	586	0.18	654	0.2	725	0.21	796	0.23	864	0.25	927	0.27	983	0.3	1034	0.33
1100	612	0.2	681	0.22	752	0.24	823	0.26	890	0.28	950	0.31	1004	0.34	1054	0.37
1200	641	0.23	711	0.25	783	0.27	852	0.29	917	0.32	975	0.35	1027	0.39	1074	0.42
1300	673	0.25	744	0.28	815	0.3	882	0.33	944	0.36	1000	0.4	1050	0.44	1096	0.48
1400	709	0.29	779	0.32	849	0.34	914	0.37	973	0.41	1026	0.45	1074	0.49	1118	0.53
1500	747	0.33	816	0.36	883	0.39	945	0.42	1001	0.46	1052	0.51	1098	0.55	1141	0.59

Air Volume cfm	External Static - in. w.g.															
	0.90		1.00		1.10		1.20		1.30		1.40		1.50		1.60	
	RPM	BHP	RPM	BHP	RPM	BHP	RPM	BHP	RPM	BHP	RPM	BHP	RPM	BHP	RPM	BHP
	Kit ZA04															
900	1065	0.32	1112	0.35	1158	0.38	1202	0.41	1243	0.44	1284	0.48	1323	0.52	1364	0.55
1000	1082	0.36	1128	0.39	1173	0.42	1216	0.45	1257	0.49	1297	0.53	1336	0.57	1375	0.6
1100	1100	0.4	1145	0.44	1189	0.47	1231	0.51	1272	0.54	1311	0.58	1349	0.62	1388	0.66
1200	1119	0.45	1163	0.49	1206	0.52	1247	0.56	1287	0.6	1326	0.64	1364	0.68	1402	0.72
1300	1139	0.51	1182	0.55	1224	0.58	1265	0.62	1304	0.66	1342	0.71	1379	0.75	1416	0.79
1400	1160	0.57	1202	0.61	1243	0.65	1283	0.69	1322	0.73	1359	0.78	1396	0.82	1432	0.87
1500	1182	0.64	1223	0.68	1263	0.72	1303	0.76	1341	0.81	1378	0.85	1414	0.9	1449	0.94

HORIZONTAL

Air Volume cfm	External Static - in. w.g.																
	0.10		0.20		0.30		0.40		0.50		0.60		0.70		0.80		
	RPM	BHP	RPM	BHP	RPM	BHP	RPM	BHP	RPM	BHP	RPM	BHP	RPM	BHP	RPM	BHP	
	Field Furnished				Kit ZA01												Kit ZA04
900	580	0.14	649	0.17	721	0.19	794	0.22	868	0.24	938	0.27	998	0.3	1045	0.33	
1000	612	0.17	681	0.19	752	0.22	825	0.25	897	0.27	963	0.3	1017	0.33	1061	0.37	
1100	647	0.2	717	0.23	788	0.26	858	0.28	926	0.31	986	0.34	1036	0.38	1077	0.41	
1200	687	0.23	757	0.26	826	0.29	893	0.32	955	0.35	1008	0.39	1054	0.42	1095	0.46	
1300	730	0.27	798	0.3	864	0.33	926	0.37	982	0.4	1030	0.44	1073	0.47	1116	0.51	
1400	775	0.31	840	0.34	902	0.38	959	0.42	1009	0.46	1054	0.5	1096	0.53	1140	0.56	
1500	820	0.36	881	0.4	939	0.44	993	0.49	1039	0.53	1082	0.56	1124	0.59	1168	0.62	

Air Volume cfm	External Static - in. w.g.															
	0.90		1.00		1.10		1.20		1.30		1.40		1.50		1.60	
	RPM	BHP	RPM	BHP	RPM	BHP	RPM	BHP	RPM	BHP	RPM	BHP	RPM	BHP	RPM	BHP
	Kit ZA04															
900	1091	0.36	1140	0.38	1188	0.4	1232	0.43	1272	0.46	1309	0.49	1346	0.53	1383	0.57
1000	1105	0.4	1154	0.42	1201	0.45	1245	0.47	1284	0.5	1321	0.54	1357	0.58	1394	0.62
1100	1121	0.44	1169	0.47	1216	0.49	1259	0.52	1298	0.56	1335	0.6	1370	0.64	1406	0.69
1200	1139	0.49	1187	0.52	1234	0.54	1276	0.58	1314	0.62	1350	0.66	1385	0.71	1421	0.75
1300	1161	0.54	1208	0.57	1254	0.6	1295	0.64	1332	0.69	1366	0.73	1401	0.78	1436	0.83
1400	1185	0.59	1232	0.63	1276	0.67	1315	0.71	1351	0.76	1384	0.81	1419	0.86	1454	0.9
1500	1212	0.66	1257	0.7	1299	0.74	1337	0.79	1371	0.84	1404	0.89	1438	0.94	1473	0.99

BLOWER DATA - BELT DRIVE - ZHA048

BLOWER TABLE INCLUDES RESISTANCE FOR BASE UNIT ONLY WITH DRY INDOOR COIL AND AIR FILTERS IN PLACE.

FOR ALL UNITS ADD:

1 - Any factory installed options air resistance (heat section, economizer, wet coil, etc.).

2 - Any field installed accessories air resistance (duct resistance, diffuser, etc.).

See page 15 for blower motors and drives and wet coil and options/accessory air resistance data.

DOWNFLOW

Air Volume cfm	External Static - in. w.g.															
	0.10		0.20		0.30		0.40		0.50		0.60		0.70		0.80	
	RPM	BHP	RPM	BHP	RPM	BHP	RPM	BHP	RPM	BHP	RPM	BHP	RPM	BHP	RPM	BHP
	Field Furnished						Kit ZA02									
1200	641	0.23	711	0.25	783	0.27	852	0.29	917	0.32	975	0.35	1027	0.39	1074	0.42
1300	673	0.25	744	0.28	815	0.30	882	0.33	944	0.36	1000	0.40	1050	0.44	1096	0.48
1400	709	0.29	779	0.32	849	0.34	914	0.37	973	0.41	1026	0.45	1074	0.49	1118	0.53
1500	747	0.33	816	0.36	883	0.39	945	0.42	1001	0.46	1052	0.51	1098	0.55	1141	0.59
1600	787	0.38	854	0.41	918	0.44	976	0.48	1030	0.52	1078	0.56	1123	0.61	1164	0.66
1700	827	0.43	892	0.46	952	0.49	1007	0.53	1058	0.58	1105	0.63	1148	0.68	1189	0.73
1800	868	0.48	929	0.52	986	0.55	1038	0.59	1087	0.64	1132	0.69	1174	0.75	1214	0.80
1900	907	0.54	966	0.58	1019	0.62	1069	0.66	1116	0.71	1160	0.77	1200	0.82	1240	0.88
2000	946	0.60	1001	0.65	1053	0.69	1101	0.74	1146	0.79	1188	0.85	1228	0.91	1267	0.98

Air Volume cfm	External Static - in. w.g.															
	0.90		1.00		1.10		1.20		1.30		1.40		1.50		1.60	
	RPM	BHP	RPM	BHP	RPM	BHP	RPM	BHP	RPM	BHP	RPM	BHP	RPM	BHP	RPM	BHP
	Kit ZA02						Kit ZA05									
1200	1119	0.45	1163	0.49	1206	0.52	1247	0.56	1287	0.60	1326	0.64	1364	0.68	1402	0.72
1300	1139	0.51	1182	0.55	1224	0.58	1265	0.62	1304	0.66	1342	0.71	1379	0.75	1416	0.79
1400	1160	0.57	1202	0.61	1243	0.65	1283	0.69	1322	0.73	1359	0.78	1396	0.82	1432	0.87
1500	1182	0.64	1223	0.68	1263	0.72	1303	0.76	1341	0.81	1378	0.85	1414	0.90	1449	0.94
1600	1205	0.70	1245	0.75	1284	0.79	1323	0.84	1361	0.88	1397	0.93	1432	0.98	1467	1.03
1700	1228	0.78	1268	0.82	1307	0.87	1345	0.92	1382	0.97	1417	1.02	1452	1.07	1486	1.11
1800	1253	0.85	1292	0.91	1331	0.96	1368	1.01	1404	1.06	1439	1.11	1473	1.16	1506	1.21
1900	1279	0.94	1317	1.00	1355	1.05	1392	1.10	1427	1.16	1461	1.21	1494	1.26	1527	1.31
2000	1305	1.04	1343	1.10	1380	1.15	1416	1.21	1450	1.26	1484	1.32	1516	1.37	1549	1.42

HORIZONTAL

Air Volume cfm	External Static - in. w.g.															
	0.10		0.20		0.30		0.40		0.50		0.60		0.70		0.80	
	RPM	BHP	RPM	BHP	RPM	BHP	RPM	BHP	RPM	BHP	RPM	BHP	RPM	BHP	RPM	BHP
	Field Furnished						Kit ZA02									
1200	687	0.23	757	0.26	826	0.29	893	0.32	955	0.35	1008	0.39	1054	0.42	1095	0.46
1300	730	0.27	798	0.30	864	0.33	926	0.37	982	0.40	1030	0.44	1073	0.47	1116	0.51
1400	775	0.31	840	0.34	902	0.38	959	0.42	1009	0.46	1054	0.50	1096	0.53	1140	0.56
1500	820	0.36	881	0.40	939	0.44	993	0.49	1039	0.53	1082	0.56	1124	0.59	1168	0.62
1600	864	0.42	921	0.46	976	0.51	1027	0.56	1072	0.60	1113	0.63	1155	0.66	1198	0.69
1700	907	0.48	961	0.53	1013	0.58	1061	0.63	1105	0.67	1146	0.70	1187	0.73	1230	0.77
1800	948	0.56	999	0.61	1049	0.66	1096	0.71	1139	0.75	1180	0.78	1221	0.82	1262	0.86
1900	987	0.64	1037	0.69	1086	0.74	1132	0.79	1174	0.83	1214	0.86	1255	0.90	1295	0.95
2000	1028	0.73	1076	0.78	1123	0.83	1168	0.87	1210	0.91	1250	0.96	1289	1.00	1328	1.06

Air Volume cfm	External Static - in. w.g.															
	0.90		1.00		1.10		1.20		1.30		1.40		1.50		1.60	
	RPM	BHP	RPM	BHP	RPM	BHP	RPM	BHP	RPM	BHP	RPM	BHP	RPM	BHP	RPM	BHP
	Kit ZA02						Kit ZA05									
1200	1139	0.49	1187	0.52	1234	0.54	1276	0.58	1314	0.62	1350	0.66	1385	0.71	1421	0.75
1300	1161	0.54	1208	0.57	1254	0.60	1295	0.64	1332	0.69	1366	0.73	1401	0.78	1436	0.83
1400	1185	0.59	1232	0.63	1276	0.67	1315	0.71	1351	0.76	1384	0.81	1419	0.86	1454	0.90
1500	1212	0.66	1257	0.70	1299	0.74	1337	0.79	1371	0.84	1404	0.89	1438	0.94	1473	0.99
1600	1242	0.73	1284	0.77	1324	0.82	1360	0.88	1394	0.93	1426	0.99	1460	1.04	1495	1.08
1700	1272	0.81	1312	0.86	1350	0.92	1385	0.98	1418	1.04	1451	1.09	1485	1.14	1519	1.19
1800	1302	0.90	1341	0.96	1377	1.02	1411	1.08	1444	1.15	1477	1.20	1510	1.25	1544	1.30
1900	1334	1.01	1371	1.07	1406	1.13	1439	1.20	1471	1.26	1504	1.32	1537	1.37	1571	1.41
2000	1365	1.12	1401	1.19	1435	1.25	1468	1.32	1500	1.38	1532	1.44	1565	1.49	1598	1.53

BLOWER DATA - BELT DRIVE - ZHA060

BLOWER TABLE INCLUDES RESISTANCE FOR BASE UNIT ONLY WITH DRY INDOOR COIL AND AIR FILTERS IN PLACE.

FOR ALL UNITS ADD:

1 - Any factory installed options air resistance (heat section, economizer, wet coil, etc.).

2 - Any field installed accessories air resistance (duct resistance, diffuser, etc.).

See page 15 for blower motors and drives and wet coil and options/accessory air resistance data.

DOWNFLOW

Air Volume cfm	External Static - in. w.g.															
	0.10		0.20		0.30		0.40		0.50		0.60		0.70		0.80	
	RPM	BHP	RPM	BHP	RPM	BHP	RPM	BHP	RPM	BHP	RPM	BHP	RPM	BHP	RPM	BHP
	Field Furnished						Kit ZA03									
1600	764	0.35	822	0.39	880	0.42	936	0.46	991	0.51	1042	0.55	1091	0.60	1136	0.64
1700	801	0.40	857	0.44	913	0.48	968	0.52	1020	0.57	1070	0.61	1117	0.66	1162	0.71
1800	838	0.46	893	0.50	947	0.54	1000	0.58	1051	0.63	1099	0.68	1145	0.73	1188	0.78
1900	876	0.52	929	0.56	982	0.61	1033	0.65	1082	0.70	1129	0.75	1173	0.80	1215	0.85
2000	914	0.59	966	0.63	1017	0.68	1067	0.72	1115	0.77	1160	0.83	1203	0.88	1244	0.94
2100	953	0.66	1004	0.71	1054	0.76	1102	0.81	1148	0.86	1192	0.92	1233	0.98	1273	1.04
2200	993	0.74	1042	0.79	1090	0.85	1137	0.90	1181	0.96	1224	1.02	1264	1.09	1303	1.15
2300	1033	0.83	1081	0.89	1128	0.94	1173	1.01	1216	1.07	1257	1.14	1296	1.20	1334	1.27
2400	1074	0.93	1120	0.99	1166	1.05	1209	1.12	1251	1.19	1291	1.26	1329	1.33	1366	1.41

Air Volume cfm	External Static - in. w.g.															
	0.90		1.00		1.10		1.20		1.30		1.40		1.50		1.60	
	RPM	BHP	RPM	BHP	RPM	BHP	RPM	BHP	RPM	BHP	RPM	BHP	RPM	BHP	RPM	BHP
	Kit ZA03										Kit ZA06					
1600	1180	0.68	1222	0.72	1263	0.76	1303	0.80	1341	0.85	1378	0.90	1414	0.94	1449	0.99
1700	1204	0.75	1245	0.79	1285	0.84	1325	0.88	1362	0.93	1398	0.98	1434	1.03	1468	1.08
1800	1229	0.83	1270	0.87	1309	0.92	1347	0.97	1384	1.02	1420	1.07	1454	1.12	1488	1.17
1900	1256	0.91	1296	0.96	1334	1.01	1371	1.07	1407	1.12	1442	1.17	1476	1.23	1509	1.28
2000	1284	1.00	1322	1.06	1360	1.11	1396	1.17	1431	1.23	1465	1.28	1498	1.33	1531	1.38
2100	1312	1.10	1350	1.16	1386	1.22	1422	1.28	1456	1.34	1489	1.40	1521	1.45	1554	1.50
2200	1341	1.22	1378	1.28	1414	1.34	1448	1.41	1481	1.46	1513	1.52	1546	1.57	1578	1.62
2300	1371	1.34	1407	1.41	1442	1.47	1475	1.54	1507	1.59	1539	1.65	1571	1.70	1602	1.75
2400	1402	1.48	1436	1.55	1470	1.61	1503	1.67	1535	1.73	1566	1.79	1597	1.84	1628	1.89

HORIZONTAL

Air Volume cfm	External Static - in. w.g.															
	0.10		0.20		0.30		0.40		0.50		0.60		0.70		0.80	
	RPM	BHP	RPM	BHP	RPM	BHP	RPM	BHP	RPM	BHP	RPM	BHP	RPM	BHP	RPM	BHP
	Field Furnished						Kit ZA03									
1600	783	0.38	844	0.41	902	0.44	957	0.48	1008	0.52	1056	0.56	1100	0.60	1142	0.64
1700	825	0.44	882	0.47	938	0.50	989	0.54	1038	0.57	1083	0.62	1126	0.66	1166	0.71
1800	866	0.50	921	0.53	973	0.56	1021	0.60	1067	0.64	1111	0.68	1152	0.73	1191	0.78
1900	907	0.56	959	0.59	1008	0.63	1054	0.66	1098	0.71	1139	0.75	1179	0.80	1217	0.86
2000	948	0.63	996	0.66	1042	0.70	1086	0.74	1128	0.78	1168	0.83	1207	0.89	1244	0.94
2100	987	0.70	1033	0.74	1077	0.78	1119	0.82	1159	0.87	1198	0.93	1235	0.99	1272	1.05
2200	1026	0.78	1070	0.82	1112	0.87	1152	0.92	1191	0.98	1228	1.03	1265	1.10	1301	1.16
2300	1064	0.88	1106	0.92	1147	0.97	1186	1.03	1223	1.09	1260	1.15	1295	1.22	1331	1.28
2400	1102	0.98	1143	1.03	1182	1.08	1220	1.15	1256	1.21	1292	1.28	1327	1.35	1362	1.42

Air Volume cfm	External Static - in. w.g.															
	0.90		1.00		1.10		1.20		1.30		1.40		1.50		1.60	
	RPM	BHP	RPM	BHP	RPM	BHP	RPM	BHP	RPM	BHP	RPM	BHP	RPM	BHP	RPM	BHP
	Kit ZA03										Kit ZA06					
1600	1183	0.68	1223	0.72	1263	0.76	1302	0.81	1340	0.86	1377	0.91	1413	0.95	1448	1.00
1700	1205	0.75	1245	0.79	1284	0.84	1322	0.89	1360	0.94	1396	0.99	1431	1.04	1465	1.09
1800	1230	0.83	1268	0.87	1306	0.92	1344	0.98	1380	1.03	1416	1.08	1450	1.13	1483	1.19
1900	1255	0.91	1292	0.96	1330	1.02	1367	1.07	1402	1.13	1437	1.18	1470	1.24	1503	1.29
2000	1281	1.00	1318	1.06	1355	1.12	1391	1.18	1425	1.23	1459	1.29	1492	1.35	1524	1.40
2100	1308	1.11	1345	1.17	1381	1.23	1416	1.29	1450	1.35	1482	1.41	1514	1.46	1546	1.52
2200	1337	1.23	1372	1.29	1408	1.35	1442	1.42	1475	1.47	1507	1.53	1538	1.59	1569	1.64
2300	1366	1.35	1401	1.42	1435	1.49	1469	1.55	1501	1.61	1532	1.67	1563	1.72	1594	1.77
2400	1396	1.49	1431	1.56	1464	1.63	1496	1.69	1528	1.75	1559	1.81	1589	1.86	1619	1.91

BLOWER DATA - BELT DRIVE - ZHB036

BLOWER TABLE INCLUDES RESISTANCE FOR BASE UNIT ONLY WITH DRY INDOOR COIL AND AIR FILTERS IN PLACE.

FOR ALL UNITS ADD:

1 - Any factory installed options air resistance (heat section, economizer, wet coil, etc.).

2 - Any field installed accessories air resistance (duct resistance, diffuser, etc.).

See page 15 for blower motors and drives and wet coil and options/accessory air resistance data.

DOWNFLOW

Air Volume cfm	External Static - in. w.g.															
	0.10		0.20		0.30		0.40		0.50		0.60		0.70		0.80	
	RPM	BHP	RPM	BHP	RPM	BHP	RPM	BHP	RPM	BHP	RPM	BHP	RPM	BHP	RPM	BHP
	Field Furnished				Kit ZA01											
900	562	0.11	621	0.13	685	0.16	752	0.18	818	0.21	883	0.24	944	0.27	1001	0.30
1000	584	0.13	644	0.16	707	0.18	773	0.21	838	0.24	901	0.27	960	0.3	1015	0.33
1100	609	0.16	669	0.18	732	0.21	796	0.24	860	0.27	921	0.30	978	0.34	1031	0.37
1200	635	0.19	696	0.21	758	0.24	821	0.27	883	0.31	942	0.34	997	0.38	1049	0.42
1300	664	0.22	725	0.25	786	0.28	848	0.31	908	0.35	965	0.39	1018	0.43	1068	0.47
1400	696	0.26	756	0.29	816	0.32	876	0.36	935	0.40	989	0.44	1041	0.48	1089	0.52
1500	729	0.30	788	0.33	848	0.37	906	0.41	962	0.45	1015	0.50	1065	0.54	1112	0.58

Air Volume cfm	External Static - in. w.g.															
	0.90		1.00		1.10		1.20		1.30		1.40		1.50		1.60	
	RPM	BHP	RPM	BHP	RPM	BHP	RPM	BHP	RPM	BHP	RPM	BHP	RPM	BHP	RPM	BHP
	Kit ZA04															
900	1053	0.32	1103	0.35	1149	0.38	1193	0.41	1234	0.43	1274	0.47	1312	0.50	1351	0.53
1000	1066	0.36	1114	0.39	1160	0.42	1204	0.45	1245	0.48	1284	0.51	1322	0.54	1361	0.58
1100	1081	0.40	1128	0.43	1173	0.46	1216	0.49	1257	0.53	1296	0.56	1334	0.60	1372	0.63
1200	1097	0.45	1144	0.48	1188	0.51	1231	0.54	1271	0.58	1310	0.62	1347	0.66	1385	0.69
1300	1115	0.50	1161	0.53	1204	0.56	1246	0.60	1286	0.64	1325	0.68	1362	0.72	1399	0.76
1400	1135	0.56	1179	0.59	1222	0.62	1264	0.66	1303	0.70	1341	0.75	1378	0.79	1415	0.83
1500	1157	0.62	1200	0.65	1242	0.69	1282	0.73	1321	0.77	1359	0.82	1396	0.86	1431	0.91

HORIZONTAL

Air Volume cfm	External Static - in. w.g.															
	0.10		0.20		0.30		0.40		0.50		0.60		0.70		0.80	
	RPM	BHP	RPM	BHP	RPM	BHP	RPM	BHP	RPM	BHP	RPM	BHP	RPM	BHP	RPM	BHP
	Field Furnished				Kit ZA01											
900	560	0.16	624	0.18	692	0.20	761	0.21	830	0.23	896	0.25	956	0.27	1012	0.29
1000	583	0.18	647	0.20	715	0.22	783	0.24	850	0.25	914	0.27	972	0.30	1025	0.33
1100	609	0.20	673	0.22	740	0.24	808	0.26	873	0.28	934	0.31	990	0.34	1041	0.37
1200	637	0.23	702	0.25	769	0.27	835	0.29	898	0.32	956	0.35	1009	0.38	1058	0.41
1300	669	0.26	734	0.28	800	0.30	863	0.33	924	0.36	979	0.39	1030	0.43	1077	0.46
1400	704	0.29	768	0.32	832	0.35	894	0.37	951	0.41	1004	0.44	1052	0.48	1097	0.52
1500	742	0.33	805	0.36	867	0.39	925	0.42	980	0.46	1030	0.50	1076	0.54	1119	0.58

Air Volume cfm	External Static - in. w.g.															
	0.90		1.00		1.10		1.20		1.30		1.40		1.50		1.60	
	RPM	BHP	RPM	BHP	RPM	BHP	RPM	BHP	RPM	BHP	RPM	BHP	RPM	BHP	RPM	BHP
	Kit ZA04															
900	1064	0.32	1114	0.35	1162	0.38	1208	0.41	1251	0.45	1293	0.49	1333	0.52	1373	0.56
1000	1076	0.36	1124	0.39	1170	0.42	1216	0.46	1259	0.49	1300	0.53	1340	0.57	1379	0.61
1100	1089	0.40	1136	0.43	1181	0.46	1225	0.50	1268	0.54	1308	0.58	1347	0.62	1386	0.66
1200	1104	0.45	1150	0.48	1194	0.51	1237	0.55	1279	0.59	1319	0.63	1357	0.67	1394	0.71
1300	1121	0.5	1165	0.53	1209	0.57	1251	0.61	1292	0.65	1331	0.69	1368	0.73	1405	0.78
1400	1140	0.56	1183	0.59	1225	0.63	1266	0.67	1306	0.71	1345	0.76	1382	0.8	1417	0.85
1500	1161	0.62	1202	0.65	1243	0.69	1284	0.73	1323	0.78	1360	0.83	1396	0.87	1432	0.92

BLOWER DATA - BELT DRIVE - ZHB048

BLOWER TABLE INCLUDES RESISTANCE FOR BASE UNIT ONLY WITH DRY INDOOR COIL AND AIR FILTERS IN PLACE.

FOR ALL UNITS ADD:

1 - Any factory installed options air resistance (heat section, economizer, wet coil, etc.).

2 - Any field installed accessories air resistance (duct resistance, diffuser, etc.).

See page 15 for blower motors and drives and wet coil and options/accessory air resistance data.

DOWNFLOW

Air Volume cfm	External Static - in. w.g.															
	0.10		0.20		0.30		0.40		0.50		0.60		0.70		0.80	
	RPM	BHP	RPM	BHP	RPM	BHP	RPM	BHP	RPM	BHP	RPM	BHP	RPM	BHP	RPM	BHP
	Field Furnished						Kit ZA02									
1200	620	0.23	681	0.29	744	0.34	809	0.39	875	0.43	941	0.47	1004	0.51	1060	0.54
1300	652	0.28	713	0.34	775	0.39	839	0.44	903	0.48	967	0.51	1025	0.55	1078	0.59
1400	687	0.33	747	0.39	809	0.44	871	0.49	934	0.53	994	0.57	1048	0.61	1098	0.64
1500	724	0.40	784	0.45	844	0.50	905	0.54	965	0.59	1021	0.62	1071	0.66	1118	0.70
1600	764	0.46	823	0.51	882	0.56	940	0.60	997	0.65	1048	0.69	1094	0.72	1140	0.75
1700	806	0.53	863	0.58	919	0.62	975	0.67	1028	0.71	1075	0.75	1119	0.78	1164	0.81
1800	849	0.60	903	0.65	957	0.69	1010	0.74	1058	0.78	1102	0.82	1145	0.85	1189	0.88
1900	892	0.68	944	0.72	995	0.77	1045	0.82	1089	0.86	1131	0.89	1174	0.92	1217	0.95
2000	935	0.76	984	0.81	1033	0.86	1079	0.91	1122	0.95	1163	0.97	1204	1.00	1247	1.03

Air Volume cfm	External Static - in. w.g.															
	0.90		1.00		1.10		1.20		1.30		1.40		1.50		1.60	
	RPM	BHP	RPM	BHP	RPM	BHP	RPM	BHP	RPM	BHP	RPM	BHP	RPM	BHP	RPM	BHP
	Kit ZA02						Kit ZA05									
1200	1111	0.58	1156	0.60	1199	0.62	1241	0.63	1284	0.65	1326	0.67	1367	0.71	1408	0.74
1300	1127	0.62	1172	0.65	1214	0.66	1256	0.68	1299	0.70	1341	0.73	1381	0.77	1421	0.81
1400	1145	0.68	1189	0.70	1231	0.72	1274	0.74	1316	0.76	1357	0.79	1397	0.83	1436	0.88
1500	1164	0.73	1208	0.75	1251	0.78	1293	0.80	1334	0.83	1374	0.86	1413	0.91	1451	0.95
1600	1185	0.79	1229	0.81	1271	0.84	1313	0.86	1354	0.90	1393	0.94	1431	0.98	1468	1.03
1700	1208	0.84	1252	0.87	1294	0.90	1335	0.94	1375	0.98	1413	1.02	1449	1.07	1485	1.12
1800	1233	0.91	1276	0.94	1318	0.98	1358	1.02	1397	1.06	1434	1.11	1469	1.16	1504	1.21
1900	1261	0.98	1303	1.02	1343	1.06	1382	1.11	1420	1.16	1455	1.21	1490	1.26	1525	1.31
2000	1289	1.07	1330	1.11	1370	1.16	1407	1.21	1444	1.27	1478	1.32	1513	1.37	1547	1.42

HORIZONTAL

Air Volume cfm	External Static - in. w.g.															
	0.10		0.20		0.30		0.40		0.50		0.60		0.70		0.80	
	RPM	BHP	RPM	BHP	RPM	BHP	RPM	BHP	RPM	BHP	RPM	BHP	RPM	BHP	RPM	BHP
	Field Furnished						Kit ZA02									
1200	614	0.21	681	0.25	752	0.30	821	0.34	888	0.39	950	0.43	1006	0.46	1057	0.49
1300	644	0.24	712	0.29	782	0.34	850	0.39	915	0.43	974	0.47	1027	0.51	1076	0.53
1400	677	0.29	746	0.34	814	0.39	880	0.44	942	0.48	998	0.52	1049	0.55	1097	0.58
1500	714	0.34	781	0.40	848	0.45	911	0.49	970	0.53	1023	0.57	1072	0.60	1119	0.63
1600	752	0.40	818	0.45	882	0.50	943	0.55	999	0.59	1050	0.62	1097	0.66	1142	0.69
1700	792	0.46	855	0.52	917	0.56	975	0.61	1028	0.64	1077	0.68	1123	0.72	1166	0.75
1800	832	0.53	894	0.58	952	0.63	1007	0.67	1058	0.70	1105	0.74	1149	0.78	1192	0.82
1900	873	0.60	932	0.65	988	0.69	1040	0.73	1088	0.77	1134	0.81	1177	0.85	1219	0.90
2000	914	0.67	970	0.72	1023	0.76	1073	0.80	1120	0.85	1163	0.89	1205	0.94	1246	0.99

Air Volume cfm	External Static - in. w.g.															
	0.90		1.00		1.10		1.20		1.30		1.40		1.50		1.60	
	RPM	BHP	RPM	BHP	RPM	BHP	RPM	BHP	RPM	BHP	RPM	BHP	RPM	BHP	RPM	BHP
	Kit ZA02						Kit ZA05									
1200	1105	0.51	1152	0.53	1197	0.55	1240	0.58	1280	0.61	1320	0.64	1358	0.68	1395	0.72
1300	1123	0.55	1169	0.57	1213	0.60	1255	0.63	1295	0.67	1334	0.70	1372	0.74	1409	0.79
1400	1142	0.60	1187	0.63	1230	0.66	1272	0.69	1312	0.73	1350	0.77	1388	0.82	1424	0.86
1500	1163	0.66	1207	0.69	1249	0.72	1290	0.76	1330	0.80	1368	0.85	1405	0.90	1441	0.94
1600	1185	0.72	1228	0.75	1270	0.79	1310	0.83	1349	0.88	1387	0.93	1423	0.98	1459	1.03
1700	1209	0.78	1251	0.82	1292	0.87	1331	0.92	1370	0.97	1407	1.02	1443	1.07	1478	1.12
1800	1234	0.86	1275	0.91	1315	0.96	1354	1.01	1391	1.06	1428	1.11	1463	1.17	1498	1.22
1900	1260	0.95	1300	1.00	1340	1.05	1377	1.11	1414	1.16	1450	1.22	1485	1.27	1519	1.32
2000	1287	1.04	1326	1.10	1365	1.16	1402	1.21	1437	1.27	1472	1.33	1507	1.38	1541	1.43

BLOWER DATA - BELT DRIVE - ZHB060

BLOWER TABLE INCLUDES RESISTANCE FOR BASE UNIT ONLY WITH DRY INDOOR COIL AND AIR FILTERS IN PLACE.

FOR ALL UNITS ADD:

1 - Any factory installed options air resistance (heat section, economizer, wet coil, etc.).

2 - Any field installed accessories air resistance (duct resistance, diffuser, etc.).

See page 15 for blower motors and drives and wet coil and options/accessory air resistance data.

DOWNFLOW

Air Volume cfm	External Static - in. w.g.															
	0.10		0.20		0.30		0.40		0.50		0.60		0.70		0.80	
	RPM	BHP	RPM	BHP	RPM	BHP	RPM	BHP	RPM	BHP	RPM	BHP	RPM	BHP	RPM	BHP
	Kit ZAA01								Kit ZAA02							
1600	522	0.27	552	0.32	585	0.37	619	0.43	656	0.48	693	0.53	732	0.59	771	0.64
1700	539	0.32	570	0.37	603	0.43	638	0.48	674	0.53	711	0.59	749	0.64	787	0.69
1800	558	0.38	589	0.43	623	0.48	658	0.54	694	0.59	730	0.64	767	0.70	803	0.75
1900	578	0.44	610	0.49	643	0.54	678	0.60	714	0.65	749	0.70	785	0.76	819	0.82
2000	600	0.50	632	0.56	665	0.61	699	0.66	734	0.71	769	0.77	803	0.83	837	0.90
2100	623	0.57	655	0.62	688	0.68	721	0.73	755	0.79	789	0.84	822	0.91	854	0.98
2200	647	0.65	678	0.70	711	0.75	743	0.81	776	0.86	809	0.93	841	1.00	872	1.06
2300	671	0.73	702	0.78	734	0.83	766	0.89	798	0.95	829	1.02	860	1.09	890	1.16
2400	696	0.81	726	0.87	757	0.92	788	0.98	819	1.04	850	1.11	880	1.19	909	1.26

Air Volume cfm	External Static - in. w.g.															
	0.90		1.00		1.10		1.20		1.30		1.40		1.50		1.60	
	RPM	BHP	RPM	BHP	RPM	BHP	RPM	BHP	RPM	BHP	RPM	BHP	RPM	BHP	RPM	BHP
	Kit ZAA02						Kit ZAA03									
1600	809	0.69	844	0.74	877	0.80	908	0.85	936	0.91	963	0.97	989	1.02	1014	1.08
1700	823	0.75	857	0.80	889	0.86	919	0.92	947	0.97	973	1.03	999	1.09	1024	1.14
1800	838	0.81	870	0.87	901	0.92	931	0.98	958	1.04	984	1.10	1009	1.16	1034	1.22
1900	853	0.88	885	0.94	915	0.99	944	1.05	971	1.11	996	1.17	1021	1.23	1045	1.29
2000	869	0.96	899	1.01	929	1.07	957	1.13	984	1.19	1009	1.25	1033	1.31	1058	1.38
2100	885	1.04	915	1.10	944	1.15	971	1.22	997	1.28	1022	1.34	1046	1.40	1070	1.46
2200	902	1.13	931	1.19	959	1.24	986	1.31	1012	1.37	1036	1.43	1060	1.50	1084	1.56
2300	920	1.23	948	1.29	975	1.35	1001	1.41	1027	1.47	1051	1.53	1075	1.60	1098	1.66
2400	938	1.33	965	1.39	992	1.45	1017	1.52	1042	1.58	1066	1.64	1090	1.70	1113	1.77

HORIZONTAL

Air Volume cfm	External Static - in. w.g.															
	0.10		0.20		0.30		0.40		0.50		0.60		0.70		0.80	
	RPM	BHP	RPM	BHP	RPM	BHP	RPM	BHP	RPM	BHP	RPM	BHP	RPM	BHP	RPM	BHP
	Kit ZAA01								Kit ZAA02							
1600	525	0.30	561	0.34	597	0.39	635	0.43	673	0.47	711	0.51	748	0.56	784	0.61
1700	543	0.34	578	0.39	615	0.43	653	0.48	691	0.52	728	0.57	765	0.62	800	0.67
1800	561	0.39	597	0.44	635	0.49	672	0.53	710	0.58	746	0.63	782	0.68	816	0.73
1900	581	0.44	618	0.49	655	0.54	692	0.59	729	0.64	765	0.69	800	0.75	833	0.80
2000	602	0.50	639	0.55	676	0.61	713	0.66	749	0.71	784	0.76	818	0.82	850	0.88
2100	625	0.57	661	0.62	698	0.67	735	0.73	770	0.78	804	0.84	837	0.90	868	0.96
2200	648	0.64	685	0.69	721	0.75	757	0.80	791	0.86	824	0.92	856	0.98	886	1.05
2300	673	0.71	709	0.77	745	0.83	780	0.88	813	0.94	845	1.01	876	1.08	905	1.15
2400	699	0.79	734	0.85	769	0.91	803	0.97	835	1.04	866	1.11	896	1.18	924	1.25

Air Volume cfm	External Static - in. w.g.															
	0.90		1.00		1.10		1.20		1.30		1.40		1.50		1.60	
	RPM	BHP	RPM	BHP	RPM	BHP	RPM	BHP	RPM	BHP	RPM	BHP	RPM	BHP	RPM	BHP
	Kit ZAA02						Kit ZAA03									
1600	819	0.66	851	0.72	883	0.77	913	0.83	943	0.89	971	0.95	998	1.01	1024	1.07
1700	833	0.72	865	0.78	896	0.84	926	0.90	954	0.96	982	1.02	1009	1.08	1034	1.14
1800	848	0.79	880	0.85	910	0.92	939	0.98	967	1.04	994	1.10	1020	1.16	1045	1.23
1900	864	0.87	895	0.93	924	0.99	953	1.06	980	1.12	1007	1.18	1032	1.25	1056	1.31
2000	881	0.95	911	1.01	940	1.08	967	1.14	994	1.21	1020	1.27	1044	1.34	1068	1.40
2100	898	1.03	927	1.10	955	1.17	982	1.23	1008	1.30	1033	1.37	1057	1.43	1080	1.50
2200	916	1.12	944	1.19	971	1.26	998	1.33	1023	1.40	1047	1.47	1071	1.54	1093	1.60
2300	934	1.22	961	1.29	988	1.36	1014	1.43	1038	1.50	1062	1.58	1085	1.65	1107	1.71
2400	952	1.32	979	1.40	1005	1.47	1030	1.54	1054	1.62	1077	1.69	1099	1.76	1121	1.83

BLOWER DATA

DRIVE KIT SPECIFICATIONS

Model No.	Blower Motor Choice (HP)				Drive Kit No.	RPM Range
	Nominal	Maximum	Nominal	Maximum		
ZHA/ZHB036	1 1	1 1.15	1.5	1.7	ZA01	678 - 1035
					ZA04	964 - 1471
ZHA/ZHB048	1 1	1 1.15	1.5	1.7	ZA02	803 - 1226
					² ZA05	1098 - 1490
ZHA060	1 1	1 1.15	1.5	1.7	ZA03	906-1383
					² ZA06	1262-1634
ZHB060	1 1	1 1.15	1.5	1.7	ZAA01	522 - 784
					ZAA02	632 - 875
					² ZAA03	798 - 1105

NOTE - Using total air volume and system static pressure requirements determine from blower performance tables rpm and motor hp required. Maximum usable hp of motors furnished are shown. In Canada, nominal motor hp is also maximum usable motor hp. If motors of comparable hp are used, be sure to keep within the service factor limitations outlined on the motor nameplate.

¹ 1 hp blower motor is not available for 208/230V-1ph applications. ² 1.5 hp motor is required with ZA05, ZA06 and ZAA03 drive kits.

POWER EXHAUST FAN PERFORMANCE

Return Air System Static Pressure - in. w.g.	Air Volume Exhausted cfm
0.00	1865
0.05	1785
0.10	1710
0.15	1630
0.20	1545
0.25	1450
0.30	1350
0.35	1240

OPTIONS / ACCESSORIES AIR RESISTANCE - in. w.g.

Air Volume cfm	Wet Indoor Coil			Electric Heat	Economizer	
	ZHA036, ZHA048	ZHA060, ZHB036	ZHB048, ZHB060		Downflow	Horizontal
900	0.01	0.01	---	0.05	0.03	0.04
1000	0.02	0.01	---	0.06	0.03	0.05
1100	0.02	0.02	---	0.08	0.04	0.05
1200	0.02	0.02	0.01	0.09	0.05	0.06
1300	0.03	0.02	0.02	0.12	0.05	0.07
1400	0.03	0.03	0.02	0.17	0.06	0.08
1500	0.04	0.03	0.02	0.22	0.07	0.08
1600	0.04	0.03	0.03	0.26	0.08	0.09
1700	0.05	0.04	0.03	0.30	0.09	0.10
1800	0.05	0.04	0.03	0.33	0.10	0.11
1900	0.06	0.05	0.04	0.33	0.11	0.12
2000	0.06	0.05	0.04	0.31	0.12	0.13
2100	---	0.06	0.05	0.27	0.13	0.14
2200	---	0.06	0.05	0.29	0.14	0.15
2300	---	0.07	0.05	0.31	0.15	0.16
2400	---	0.07	0.06	0.32	0.16	0.18

CEILING DIFFUSERS AIR RESISTANCE (in. w.g.)

Air Volume cfm	RTD9-65 Step-Down Diffuser			FD9-65 Flush Diffuser
	2 Ends Open	1 Side & 2 Ends Open	All Ends & Sides Open	
800	0.15	0.13	0.11	0.11
1000	0.19	0.16	0.14	0.14
1200	0.25	0.20	0.17	0.17
1400	0.33	0.26	0.20	0.20
1600	0.43	0.32	0.20	0.24
1800	0.56	0.40	0.30	0.30
2000	0.73	0.50	0.36	0.36
2200	0.95	0.63	0.44	0.44

CEILING DIFFUSER AIR THROW DATA

Air Volume - cfm	¹ Effective Throw - ft.	
	RTD9-65	FD9-65
800	10 - 17	14 - 18
1000	10 - 17	15 - 20
1200	11 - 18	16 - 22
1400	12 - 19	17 - 24
1600	12 - 20	18 - 25
1800	13 - 21	20 - 28
2000	14 - 23	21 - 29
2200	16 - 25	22 - 30

¹ Effective throw based on terminal velocities of 75 ft. per minute.

**TABLE 2
DRIVE COMPONENT MANUFACTURER'S NUMBERS**

Drive No.	DRIVE COMPONENT PART NUMBERS					
	Motor Pulley		Blower Pulley		Belts	
	Browning	OEM	Browning	OEM	Browning	OEM
Z01	1VP34 X 7/8	31K6901	AK54 X 5/8	100244-30	A40	100245-17
Z02	1VP34 X 7/8	31K6901	AK46 X 5/8	100244-31	A39	100245-16
Z03	1VP34 X 7/8	31K6901	AK41 X 5/8	100244-28	A39	100245-16
Z04	1VP34 X 7/8	31K6901	AK39 X 5/8	100244-32	A38	100245-15
Z05	1VP44 X 7/8	P-8-1488	AK49 X 5/8	100244-26	A41	100245-18
Z06	1VP50 X 7/8	53J1501	AK51 X 5/8	100244-29	A42	100245-19
ZAA01	1VP34 X 7/8	31K69	AK69 X 1	37L47	AX51	13H01
ZAA02	1VP40 X 7/8	79J03	BK80H	100788-03	A53	100245-40
ZAA03	1VP40 X 7/8	79J03	AK59 X 1	31K68	A50	100245-29

**TABLE 3
MINIMUM AIRFLOW - UNITS WITH ELECTRIC HEAT**

kW	CFM - Downflow and Horizontal	
	ZHA036-060, ZHB036-048	ZHB060
5	960	1750
7.5	960	1750
10	960	1750
15	960	1750
22.5	1280	1750

Units with electric heat (5-22.5kW) can operate up to 1.6" w.g. maximum static pressure.

Start-Up

▲ IMPORTANT

This unit is equipped with a crankcase heater. Make sure heater is energized 24 hours before unit start-up to prevent compressor damage as a result of slugging.

A-Start-Up

Heating

- 1- Set thermostat or temperature control device to initiate a first-stage heating demand.
- 2- A first-stage heating demand (W1) will energize compressors 1 and the outdoor fan.

Note - L1 reversing valve is de-energized in the heating mode.

ZH Units With Optional Electric Heat -

An increased heating demand (W2) will energize electric heat. Electric heat is also energized during the defrost cycle (W1) to maintain discharge air temperature.

Cooling

- 1- Set thermostat or temperature control device fan switch to **AUTO** or **ON**. Set thermostat or temperature control device to initiate a first-stage cooling demand.

A first-stage Y1 cooling demand will energize L1 reversing valve solenoid and compressor 1.

Units With Optional Economizer -

The optional economizer will start on a first stage (Y1) cooling demand when outdoor air is suitable. An increased cooling demand (Y2) will energize compressor 1.

- 2- Refrigerant circuits are factory charged with R-410A refrigerant. See unit rating plate for correct amount of charge.

B-Three Phase Scroll Compressor Voltage Phasing

Three phase scroll compressors must be phased sequentially to ensure correct compressor and blower rotation and operation. Compressor and blower are wired in phase at the factory. Power wires are color-coded as follows: line 1-red, line 2-yellow, line 3-blue.

- 1- Observe suction and discharge pressures and blower rotation on unit start-up.
- 2- Suction pressure must drop, discharge pressure must rise, and blower rotation must match rotation marking.

If pressure differential is not observed or blower rotation is not correct:

- 3- Disconnect all remote electrical power supplies.
- 4- Reverse any two field-installed wires connected to the line side of K1 contactor. Do not reverse wires at blower contactor.

Make sure the connections are tight.

Discharge and suction pressures should operate at their normal start-up ranges.

C - Refrigerant Charge and Check

WARNING-Do not exceed nameplate charge under any condition.

This unit is factory charged and should require no further adjustment. If the system requires additional refrigerant, reclaim the charge, evacuate the system, and add required nameplate charge.

*NOTE - System charging is not recommended below 60°F (15°C). In temperatures below 60°F (15°C), the charge **must** be weighed into the system.*

If weighing facilities are not available, or to check the charge, use the following procedure:

IMPORTANT - Charge unit in standard cooling mode high stage only.

- 1- Make sure outdoor coil is clean. Attach gauge manifolds and operate unit at full CFM in cooling mode with economizer disabled until system stabilizes (approximately five minutes). Make sure all outdoor air dampers are closed.
- 2- Compare the normal operating pressures (see tables 4 - 9) to the pressures obtained from the gauges. Check unit components if there are significant differences.
- 3- Measure the outdoor ambient temperature and the suction pressure. Refer to the appropriate circuit charging curve to determine a target liquid temperature.

Note - Pressures are listed for sea level applications.

- 4- Use the same thermometer to accurately measure the liquid temperature (in the outdoor section).
 - If measured liquid temperature is higher than the target liquid temperature, add refrigerant to the system.
 - If measured liquid temperature is lower than the target liquid temperature, recover some refrigerant from the system.
- 5- Add or remove charge in increments. Allow the system to stabilize each time refrigerant is added or removed.

6- Continue the process until measured liquid temperature agrees with the target liquid temperature. Do not go below the target liquid temperature when adjusting charge. Note that suction pressure can change as charge is adjusted.

7- Example ZHA036: At 95°F outdoor ambient and a measured suction pressure of 130psig, the target liquid temperature is 105.5°F. For a measured liquid temperature of 106°F, add charge in increments until measured liquid temperature agrees with the target liquid temperature.

D - Compressor Controls

See unit wiring diagram to determine which controls are used in each unit. Optional controls are identified on wiring diagrams by arrows at junction points.

- 1- Defrost Switch (S6)
Defrost switch closes to initiate defrost when liquid line temperature falls to 42°F (5.6°C). Defrost switch opens when liquid line temperature reaches 70°F (21°C) to terminate defrost. If the liquid line temperature does not rise above 70°F (21°C), the CMC1 will terminate defrost after 14 minutes. The defrost switch is located on the liquid line between the outdoor expansion valve and the distributor
- 2- Defrost Control (CMC1)
Defrost is liquid line temperature initiated and operates for 14 minutes unless terminated by liquid line temperature.

When the liquid line temperature drops below 42°F (5.6°C), the defrost switch closes and signals the **defrost control** that a defrost cycle is needed. If the defrost switch is still closed after 90 minutes (default), a defrost cycle begins and operates for up to 14 minutes. The defrost switch can terminate the defrost cycle before the 14 minutes elapses if liquid line temperature reaches 70°F (21°C)

Electric heat is energized during defrost to maintain discharge air temperature.

**TABLE 4
ZHA036 NORMAL OPERATING PRESSURES**

Outdoor Coil Entering Air Temperature											
65 °F		75 °F		85 °F		95 °F		105 °F		115 °F	
Suct (psig)	Disc (psig)	Suct (psig)	Disc (psig)	Suct (psig)	Disc (psig)	Suct (psig)	Disc (psig)	Suct (psig)	Disc (psig)	Suct (psig)	Disc (psig)
119	235	122	272	124	314	126	359	129	409	132	461
128	241	130	279	132	319	136	364	146	421	140	470
139	245	146	285	151	331	155	377	155	428	159	482
145	248	154	290	163	335	170	384	174	438	179	498

**TABLE 5
ZHA048 NORMAL OPERATING PRESSURES**

Outdoor Coil Entering Air Temperature											
65 °F		75 °F		85 °F		95 °F		105 °F		115 °F	
Suct (psig)	Disc (psig)	Suct (psig)	Disc (psig)	Suct (psig)	Disc (psig)	Suct (psig)	Disc (psig)	Suct (psig)	Disc (psig)	Suct (psig)	Disc (psig)
113	253	116	293	119	336	122	383	125	435	128	492
121	258	123	297	126	341	129	387	133	440	137	498
133	267	138	308	143	354	146	401	151	459	154	516
140	273	148	317	155	366	161	418	167	475	172	536

**TABLE 6
ZHA060 NORMAL OPERATING PRESSURES**

Outdoor Coil Entering Air Temperature											
65 °F		75 °F		85 °F		95 °F		105 °F		115 °F	
Suct (psig)	Disc (psig)	Suct (psig)	Disc (psig)	Suct (psig)	Disc (psig)	Suct (psig)	Disc (psig)	Suct (psig)	Disc (psig)	Suct (psig)	Disc (psig)
113	254	115	292	119	335	122	380	125	430	128	487
121	260	123	299	126	343	130	391	134	440	137	496
130	265	138	308	143	354	147	404	151	456	154	513
136	270	145	315	153	364	160	414	167	471	172	529

**TABLE 7
ZHB036 NORMAL OPERATING PRESSURES**

Outdoor Coil Entering Air Temperature											
65 °F		75 °F		85 °F		95 °F		105 °F		115 °F	
Suct (psig)	Disc (psig)	Suct (psig)	Disc (psig)	Suct (psig)	Disc (psig)	Suct (psig)	Disc (psig)	Suct (psig)	Disc (psig)	Suct (psig)	Disc (psig)
119	236	122	274	125	315	128	361	130	410	133	464
126	239	128	278	132	320	136	366	138	416	141	471
135	245	144	285	151	330	153	380	158	429	161	487
140	250	151	290	159	335	167	385	174	440	178	498

**TABLE 8
ZHB048 NORMAL OPERATING PRESSURES**

Outdoor Coil Entering Air Temperature											
65 °F		75 °F		85 °F		95 °F		105 °F		115 °F	
Suct (psig)	Disc (psig)	Suct (psig)	Disc (psig)	Suct (psig)	Disc (psig)	Suct (psig)	Disc (psig)	Suct (psig)	Disc (psig)	Suct (psig)	Disc (psig)
116	248	119	287	121	328	123	374	126	423	128	477
123	252	127	292	129	336	132	382	135	433	137	487
133	260	140	302	145	347	148	395	152	451	156	505
137	264	146	308	154	357	162	409	168	464	173	523

**TABLE 9
ZHB060 NORMAL OPERATING PRESSURES**

Outdoor Coil Entering Air Temperature											
65 °F		75 °F		85 °F		95 °F		105 °F		115 °F	
Suct (psig)	Disc (psig)	Suct (psig)	Disc (psig)	Suct (psig)	Disc (psig)	Suct (psig)	Disc (psig)	Suct (psig)	Disc (psig)	Suct (psig)	Disc (psig)
114	255	118	297	120	338	123	387	126	433	130	487
121	257	125	298	131	350	131	389	134	443	137	504
131	267	138	311	144	362	148	410	152	457	153	524
137	269	143	315	154	364	162	417	167	474	169	534

ZHA 036 CHARGING CURVE

Outdoor Temperature (°F)

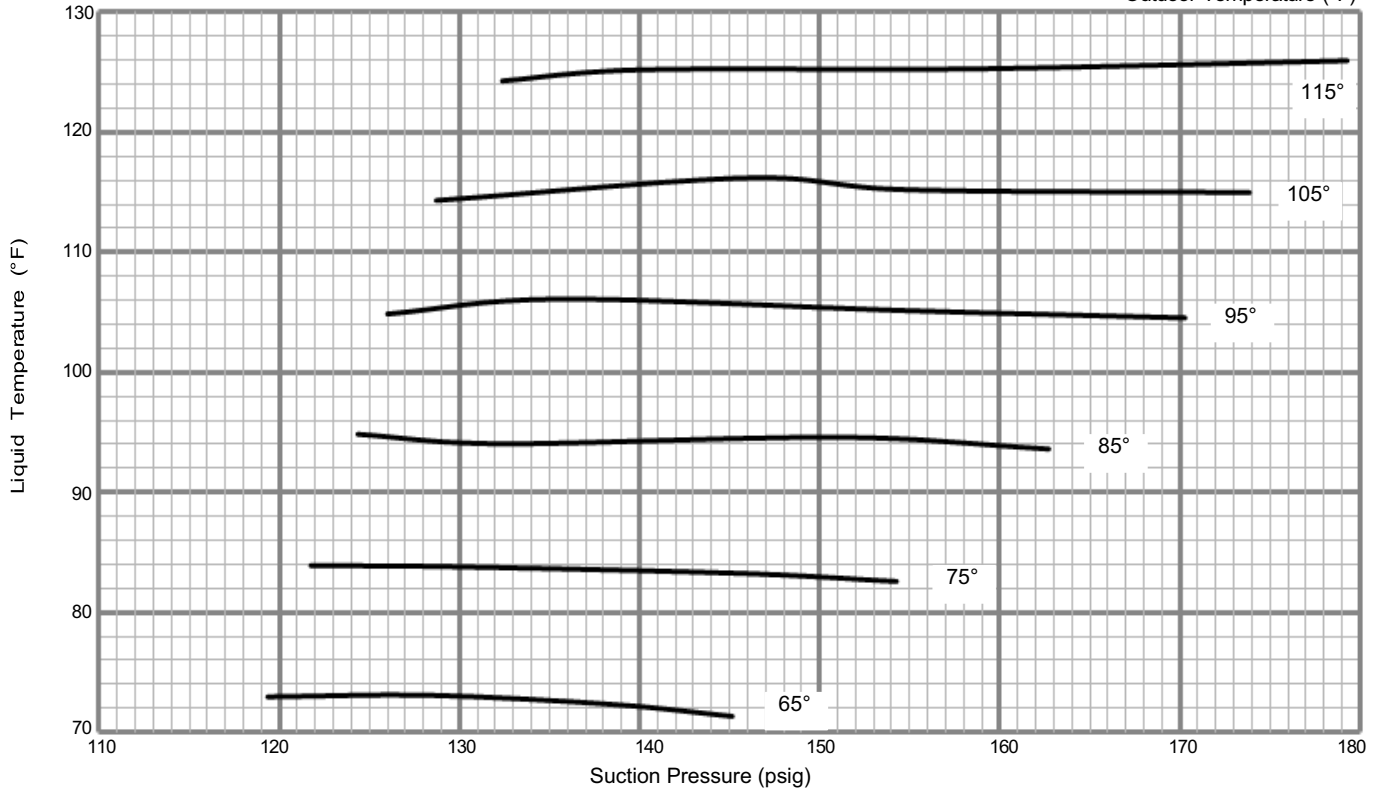

ZHA048 CHARGING CURVE

Outdoor Temperature (°F)

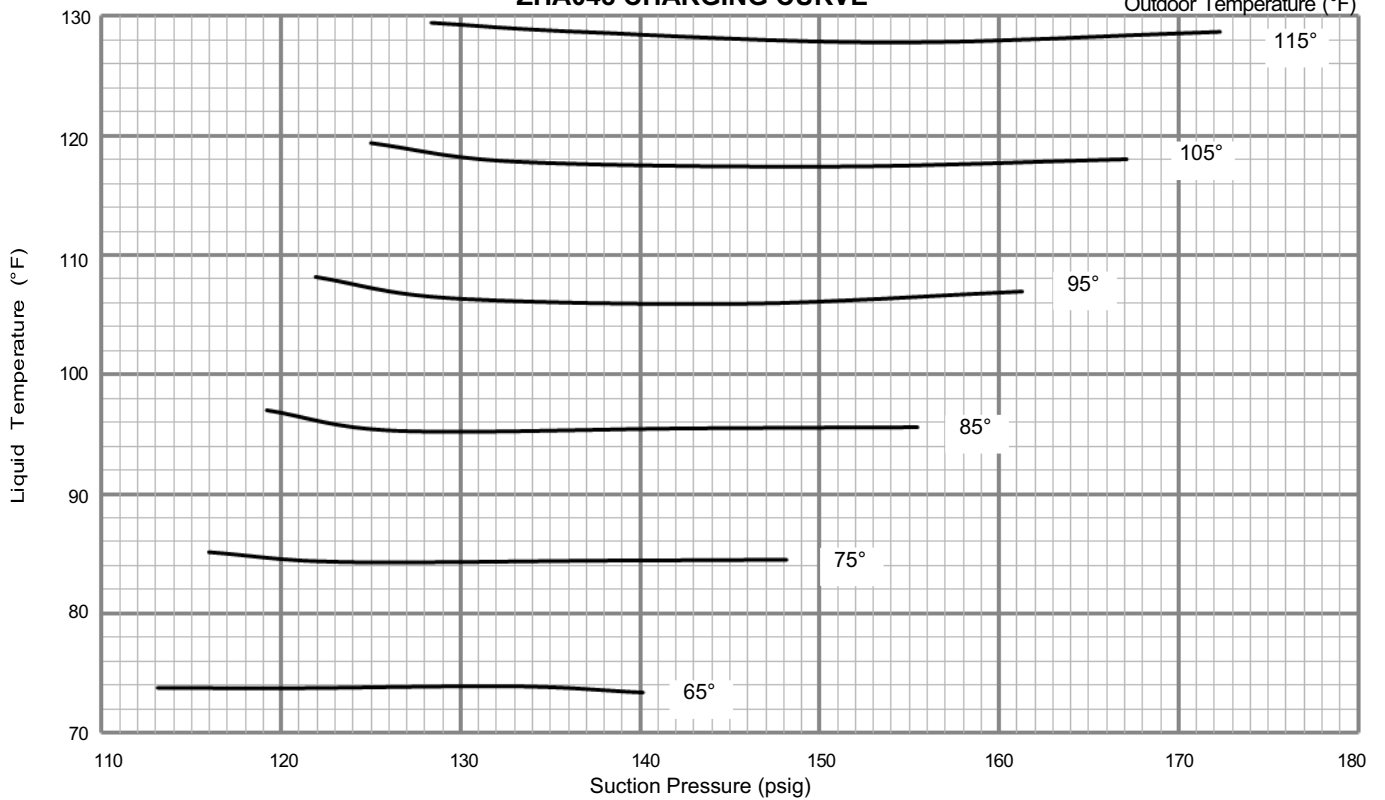

ZHA060 CHARGING CURVE

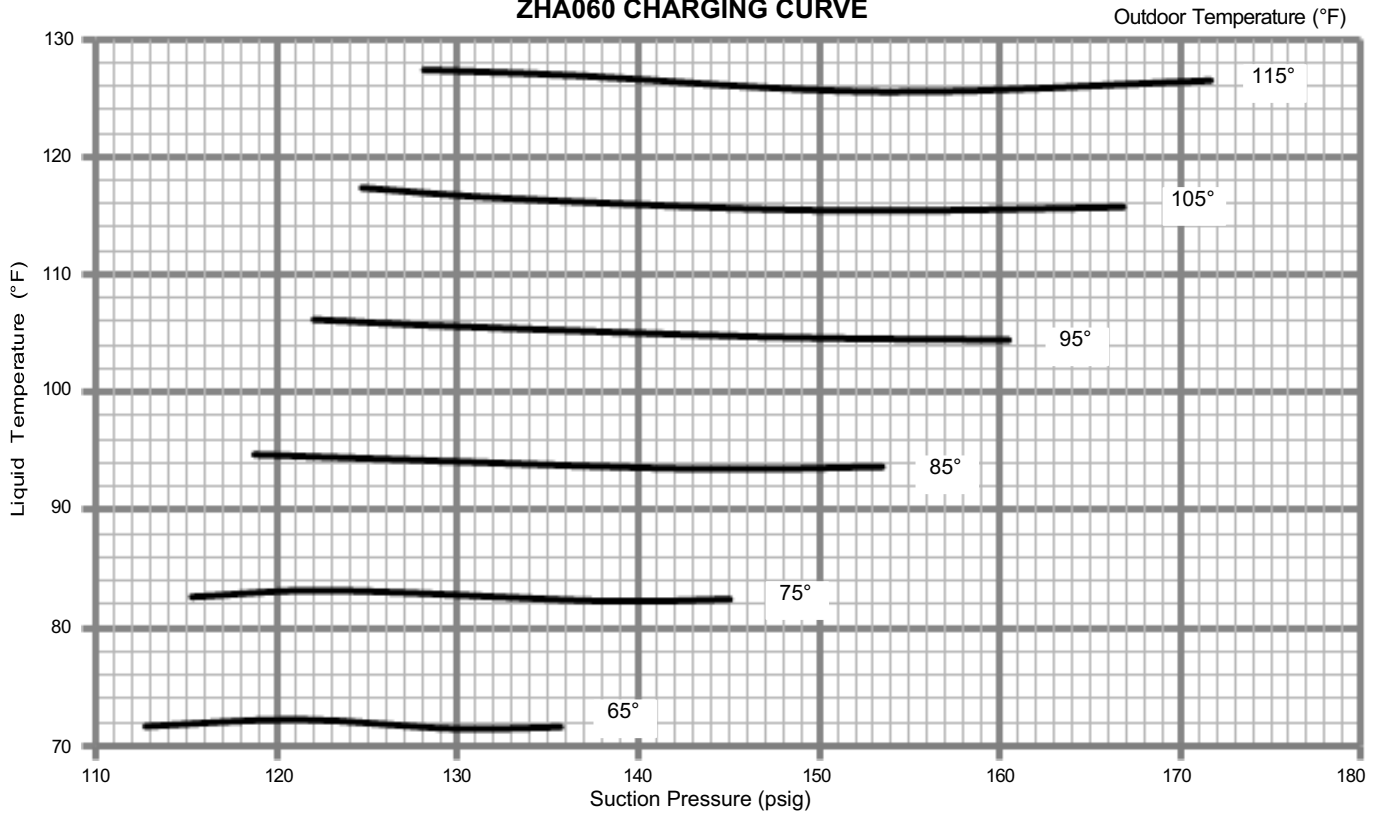

ZHB 036 CHARGING CURVE

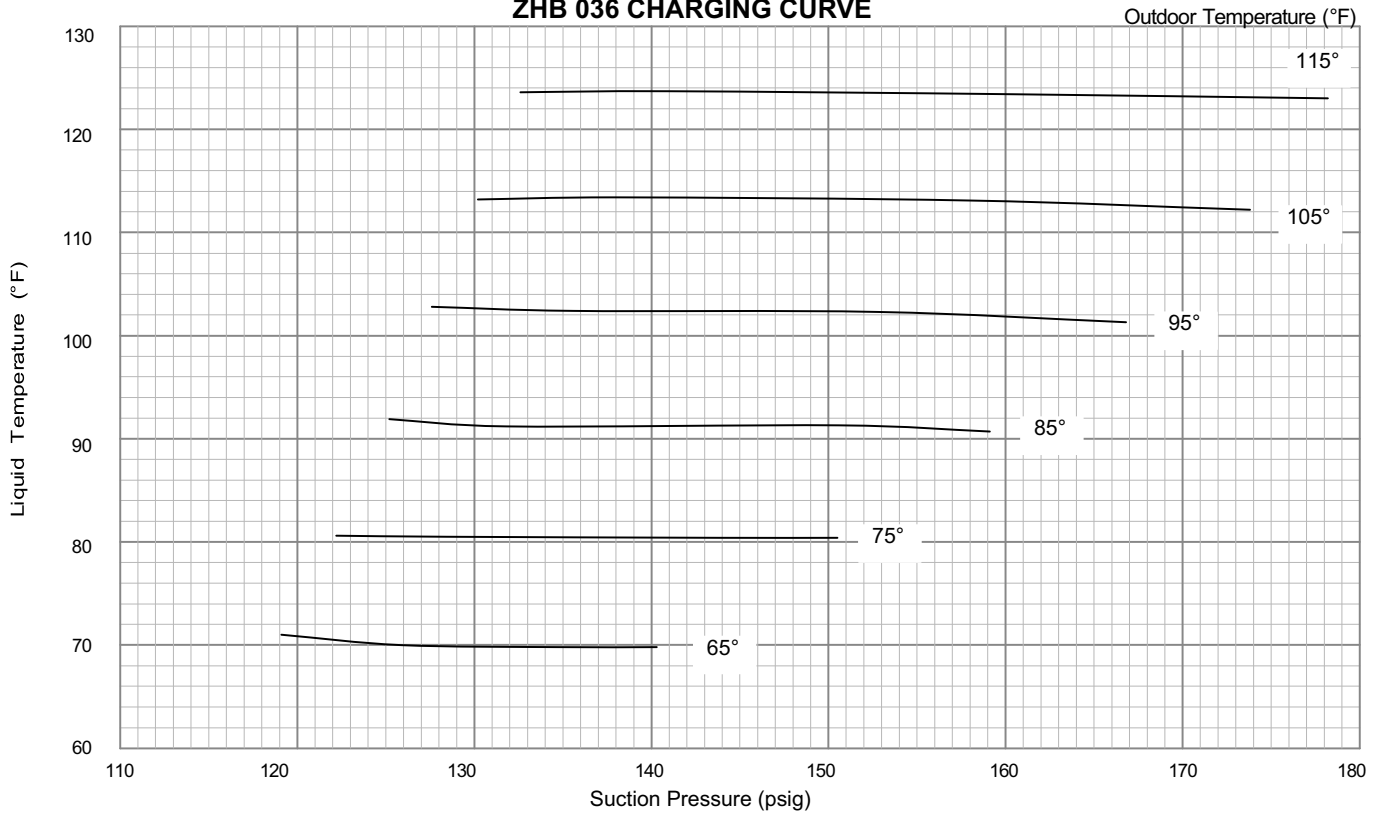

ZHB048 CHARGING CURVE

Outdoor Temperature (°F)

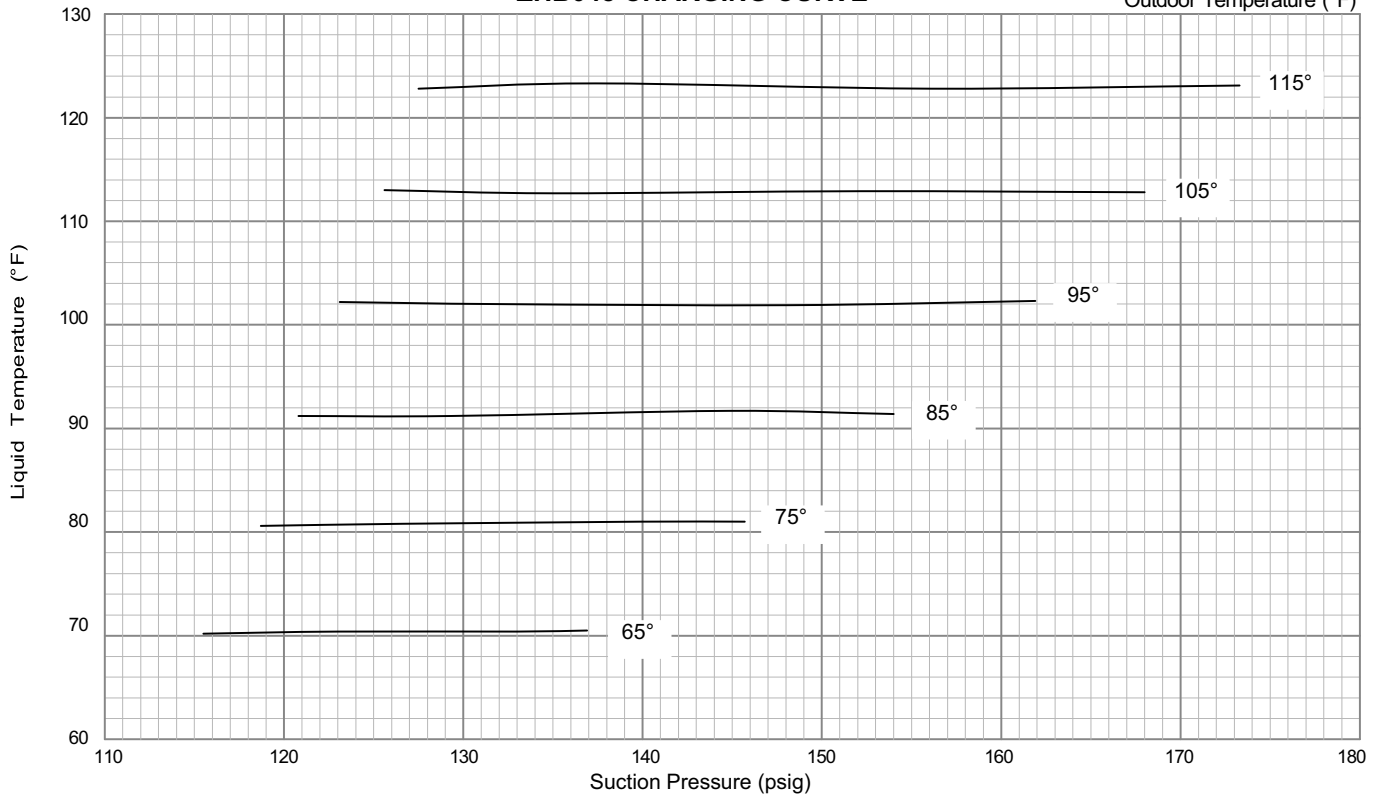

ZHB060 CHARGING CURVE

Outdoor Temperature (°F)

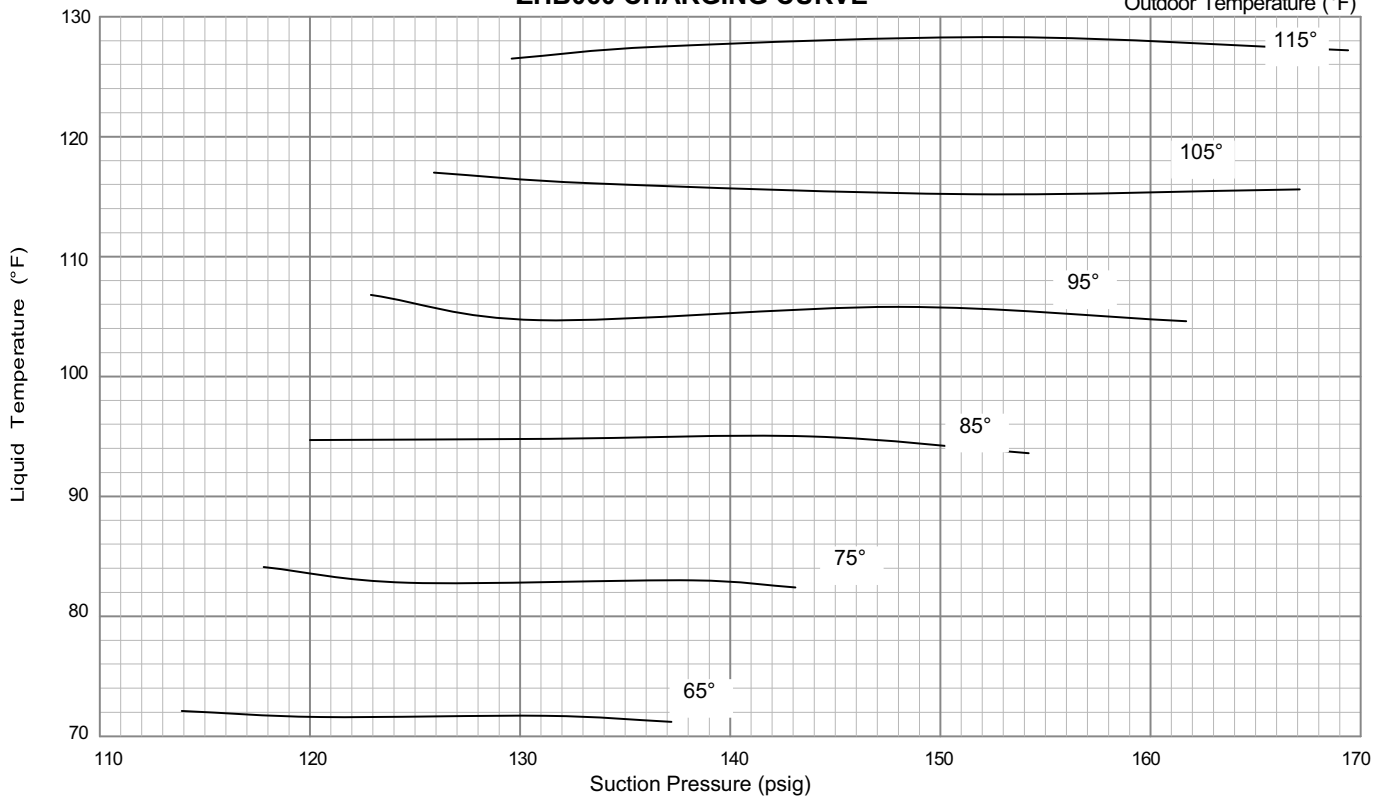

Defrost Control Board

The defrost thermostat and the defrost control work together to ensure that the heat pump outdoor coil does not ice excessively during the heating mode.

Compressor Accumulated Run-Time Interval

The defrost control will not energize a defrost cycle unless the unit has been operating in heating mode for an accumulated 90 minutes (default). The run time interval can be changed by moving the jumper on the CMC board timing pins. See figure 13.

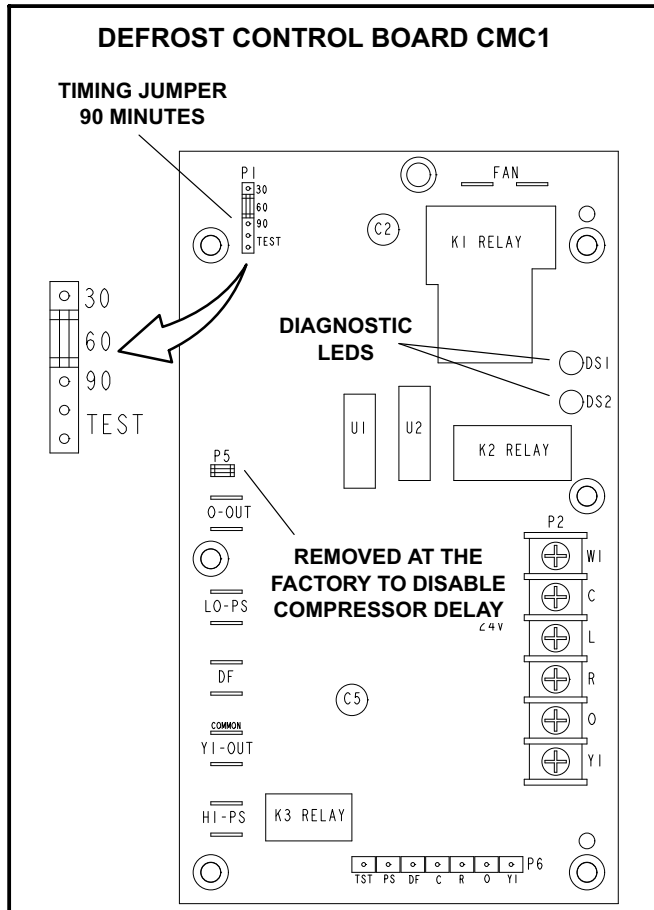

FIGURE 13

The defrost interval can be adjusted to 30, 60, or 90 minutes. The defrost timing jumper is factory-installed to provide a 90-minute defrost interval. If the timing selector jumper is not in place, the control defaults to a 90-minute defrost interval.

Defrost Test Option

A TEST option is provided for troubleshooting. The TEST mode may be started any time the unit is in the heating mode and the defrost thermostat is closed or jumpered. If the timing jumper is in the TEST position at power-up, the defrost control will ignore the test pins. When the jumper is placed across the TEST pins for two seconds, the control will enter the defrost mode. If the jumper is removed before an additional 5-second period has elapsed (7 seconds total), the unit will remain in defrost mode until the defrost switch opens or 14 minutes have passed. If the jumper is not removed until after the additional 5-second period has elapsed, the defrost will terminate and the test option will not function again until the jumper is removed and re-applied.

Diagnostic LEDs

The defrost board uses two LEDs for diagnostics. The LEDs flash a sequence according to the condition.

TABLE 10

Defrost Control Board Diagnostic LED		
Mode	Green LED (DS2)	Red LED (DS1)
No power to control	OFF	OFF
Normal operation / power to control	Simultaneous Slow FLASH	
Anti-short cycle lockout	Alternating Slow FLASH	
High pressure switch fault	Slow FLASH	OFF
High pressure switch lockout	ON	OFF

Service

The unit should be inspected once a year by a qualified service technician.

⚠ CAUTION

Label all wires prior to disconnection when servicing controls. Wiring errors can cause improper and dangerous operation. Verify proper operation after servicing.

⚠ WARNING

The State of California has determined that this product may contain or produce a chemical or chemicals, in very low doses, which may cause serious illness or death. It may also cause cancer, birth defects, or reproductive harm.

A - Lubrication

All motors are lubricated at the factory. No further lubrication is required.

B-Compressor

If Interlink compressor replacement is necessary, call 1-800-4-LENNOX (1-800-453-6669).

⚠ IMPORTANT

Some scroll compressors have an internal vacuum protector that will unload scrolls when suction pressure goes below 20 psig. A hissing sound will be heard when the compressor is running unloaded. Protector will reset when low pressure in system rises above 40 psig. **DO NOT REPLACE COMPRESSOR.**

C - Filters

Units are equipped with temporary filters which must be replaced prior to building occupation. See table 11 for correct filter size. Refer to local codes or appropriate jurisdiction for approved filters.

To change filters, open filter access panel on back side of unit. See figure 14. Lift filter stop to remove filters. See figure 15.

⚠ WARNING

Units are shipped from the factory with temporary filters. Replace filters before building is occupied. Damage to unit could result if filters are not replaced with approved filters. Refer to appropriate codes.

Approved filters should be checked monthly and replaced when necessary. Take note of air flow direction marking on filter frame when reinstalling filters. See figure 15.

**TABLE 11
UNIT FILTERS**

Unit	Qty	Filter Size - inches (mm)
ZHA036, 048	4	14 X 20 X 2 (352 X 508 X 51)
ZHA060, ZHB036	4	16 X 20 X 2 (406 X 508 X 51)
ZHB048, 060	2 Each	16 X 20 X 2 (406 X 508 X 51) 20 X 20 X 2 (508 X 508 X 51)

NOTE-Filters must be U.L.C. certified or equivalent for use in Canada.

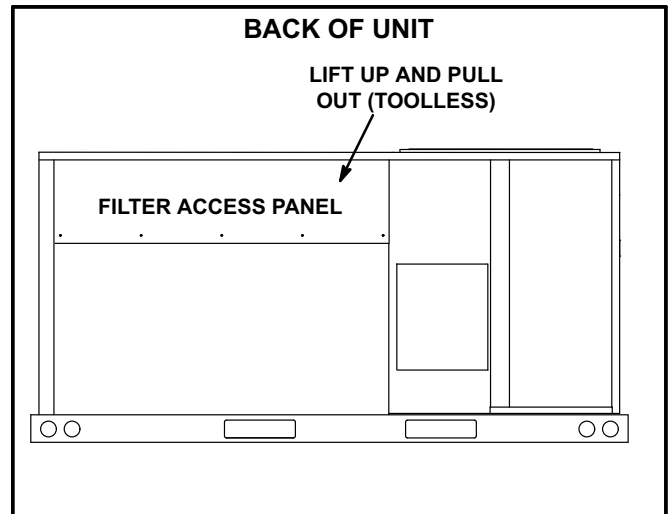

FIGURE 14

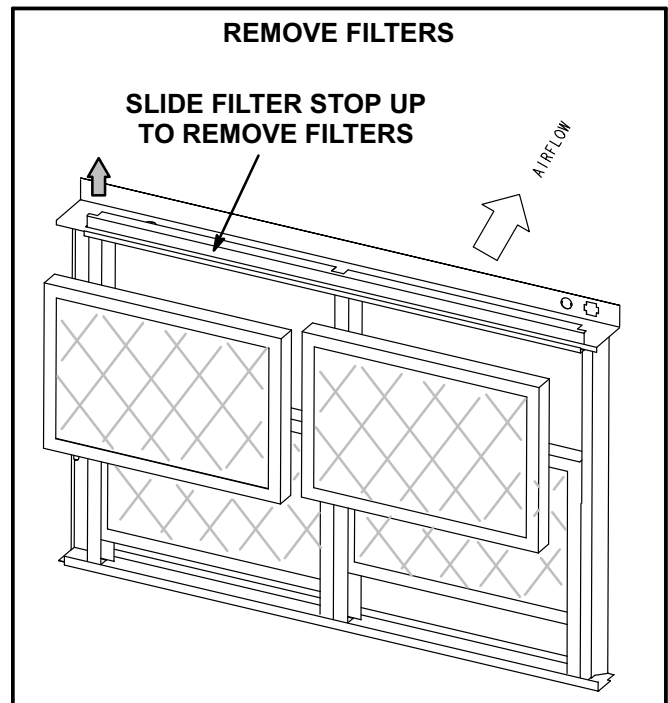

FIGURE 15

D - Supply Air Blower Wheel

Annually inspect supply air blower wheel for accumulated dirt or dust. Turn off power before attempting to remove access panel or to clean blower wheel.

E - Indoor Coil

Inspect and clean coil at beginning of each cooling and heating season. Clean using mild detergent or commercial coil cleanser. Flush coil and condensate drain with water taking care not to get insulation, filters and return air ducts wet.

F - Outdoor Coil

Clean outdoor coil annually with detergent or commercial coil cleaner and inspect monthly during the cooling season.

Outdoor coils are made of single and two formed slabs. On units with two slabs, dirt and debris may become trapped between the slabs. To clean between slabs, carefully separate coil slabs and wash them thoroughly. See figure 16. Flush coils with water following cleaning.

Note - Remove all screws and gaskets prior to cleaning procedure and replace upon completion.

G - Filter Drier

The unit is equipped with a biflow filter drier. if replacement is necessary, order another of like design.

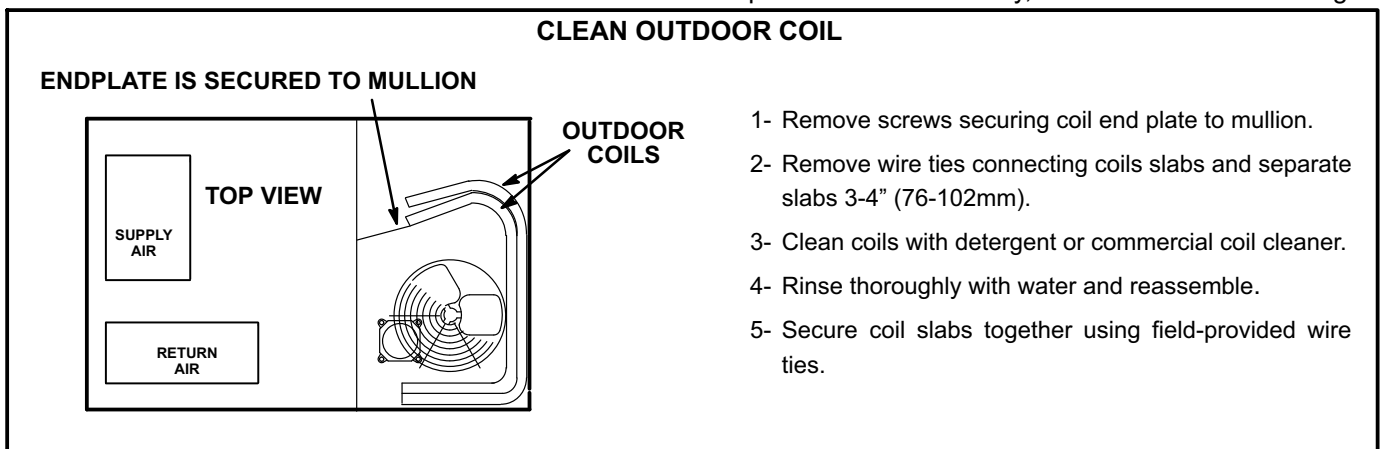

FIGURE 16