

**INSTALLATION INSTRUCTIONS FOR ECONOMIZERS USED WITH
LG/LC 092-152 B BOX UNITS**

Note - When the economizer is factory-installed, refer to GED hood installation on Page 4 and outdoor air hood installation on Page 6.

Shipping and Packing List

Package 1 of 1 contains:

- 1 - Economizer damper assembly
- 1 - Gravity exhaust damper (GED) assembly
- 1 - Bag assembly containing:
 - #10 - 16 X 5/8" sheet metal screws
 - #12 - 14 X 5/8" self-drilling/self-tapping screws
 - #10 - 32 X 1/2" thread-forming screw
 - #4 - 40 X 3/8" thread-forming screws
 - #8 - 32 X 1/2" thread-forming screws
 - #6 - 32 thread-forming screws
 - 1 - Insertion wire tie
 - 1 - Wiring harness (P104)
 - 1 - Harness (J262A)
- 1 - **Hood package (shipped inside economizer package) contains:**
 - 1 - Outdoor air hood top seal
 - 1 - Outdoor air hood top
 - 2 - Outdoor air hood sides (left and right)
 - 1 - Outdoor air hood bottom filter bracket
 - 1 - Top filter seal bracket
 - 1 - Filter spacer
 - 2 - Filters
 - 1 - Gravity exhaust hood top
 - 1 - Gravity exhaust hood top support
 - 2 - Gravity exhaust hood sides (left and right)

NOTE - For horizontal applications, order K1HECK horizontal discharge kit separately.

NOTE - Gravity exhaust dampers are required for use with economizers and must be installed. For low profile horizontal applications, order LAGEDH separately. See table 1.

⚠ WARNING

Improper installation, adjustment, alteration, service or maintenance can cause property damage, personal injury or loss of life. Installation and service must be performed by a qualified installer, service agency or the gas supplier

Application

The E1ECON economizer is used with LG/LC units in downflow and horizontal air discharge applications. See table 1. The economizer uses outdoor air for free cooling when temperature and/or humidity is suitable. LG/LC units are equipped with the following factory-installed, CEC Title 24 approved sensors:

- RT17 - Outside Air Temperature
- RT16 - Return Air Temperature
- RT6 - Discharge Air Temperature

**TABLE 1
Economizer**

Kit Description	Part No.	
Standard	13U46	603366-06
High Performance	10U59	603366-04
Low Profile GED - Horizontal Applications	53K04	LB-68922F

See figure 14 in the *Start-Up* section for sensor location.

Optional field-provided sensors may be used instead of unit sensors to determine whether outdoor air is suitable for free cooling. Refer to table 5 or 9.

Gravity exhaust dampers allow exhaust air to be discharged from the system when an economizer and/or power exhaust is operating. Gravity exhaust dampers also prevent outdoor air infiltration during unit off cycle.

GED dampers are used in downflow air discharge applications. LAGEDH dampers are used in horizontal air discharge applications and are installed in the return air plenum.

Gravity exhaust dampers must be used any time a power exhaust damper is installed in LG/LC unit. A gravity exhaust damper is required in the system when an economizer is installed unless other provisions are made to exhaust indoor air.

NOTICE

- Install accessories in the following order:**
- 1-Outdoor air or economizer dampers
 - 2-Sensors (installation and wiring)
 - 3-Gravity exhaust dampers
 - 4Gravity exhaust damper hoods
 - 5-Outdoor air hoods

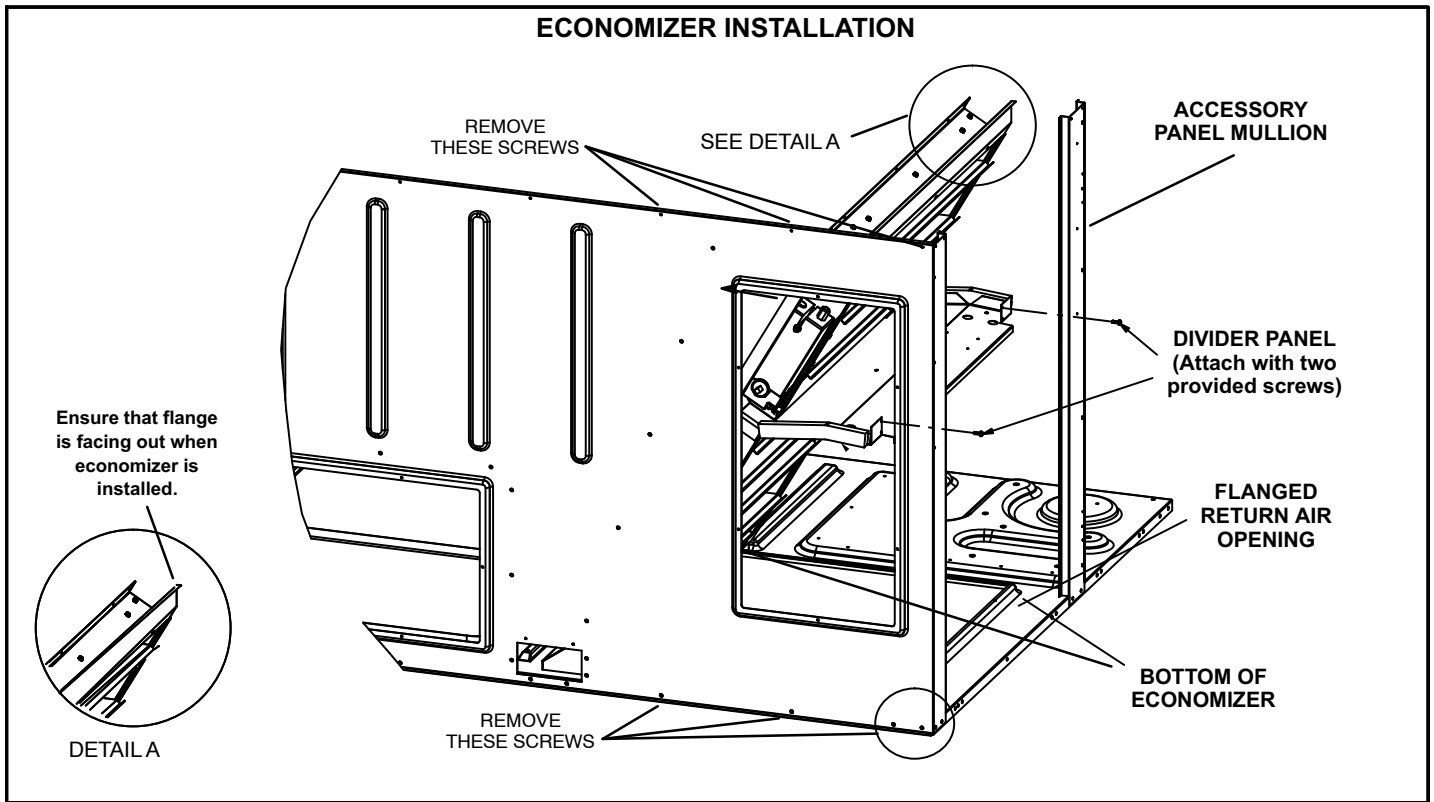

FIGURE 1

⚠ CAUTION

Danger of sharp metallic edges. Can cause injury. Take care when servicing unit to avoid accidental contact with sharp edges.

Install Economizer - Downflow

- 1- Disconnect all power to unit.
- 2- Remove accessory compartment access panel.
- 3- Remove and retain screws from top and bottom of rear panel. Lift the top of the unit as needed. See figure 1.
- 4- Slide the bottom of the economizer over the flanged return air opening in the base of the unit until it settles into place. See figure 1.
- 5- Use provided screws to secure economizer divider panel to unit end mullion and accessory compartment mullion as shown in figure 1.
- 6- Before securing unit top panel with retained screws, position the outdoor air hood top seal under the panel as shown in figures 11 and 12. The outdoor air hood top seal is shipped with the other outdoor air hood components.
- 7- Use provided screws to secure top of economizer assembly to unit top panel.

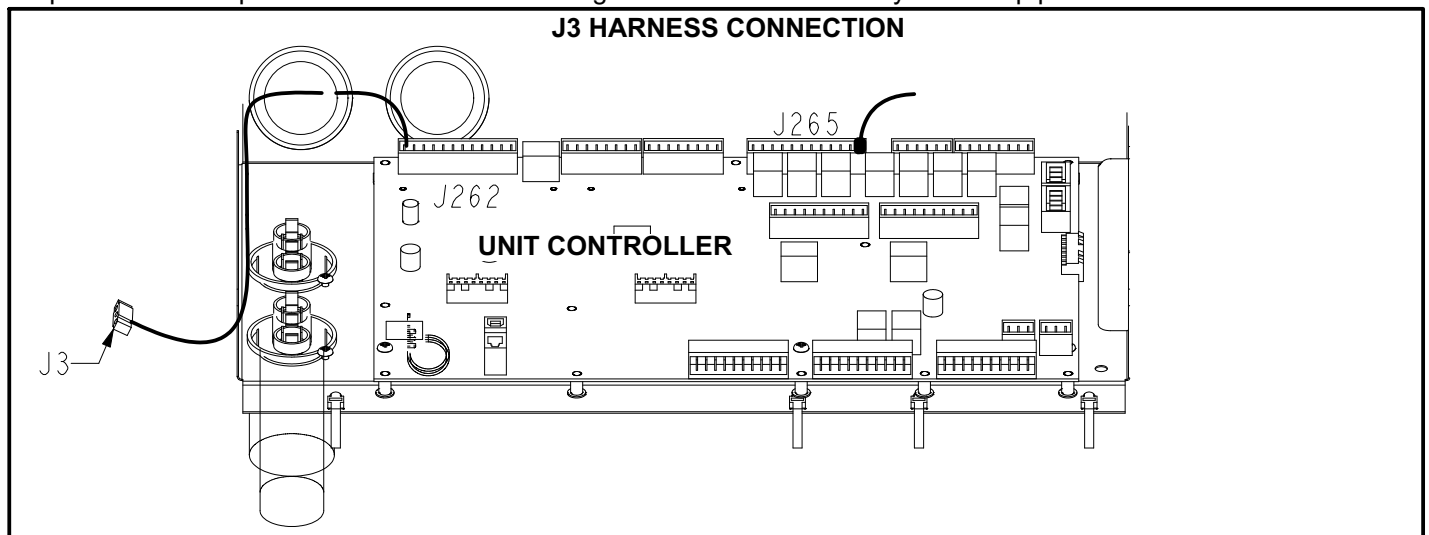

FIGURE 2

- 8- Connect J262A connector to P262 as shown in figure 2. Insert J3 from J262A harness into opening in unit wall as shown in figure 3.

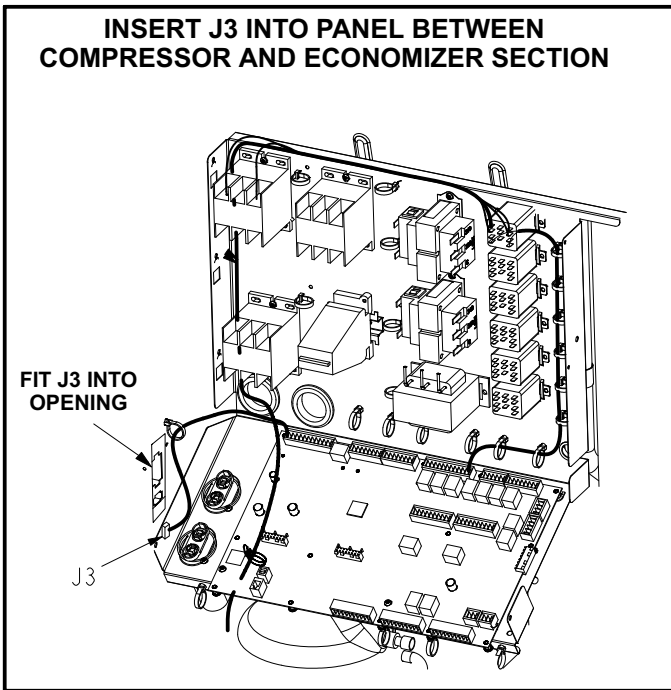

FIGURE 3

- 9- Connect economizer plug P3 to unit jack J3 as shown in figure 4.

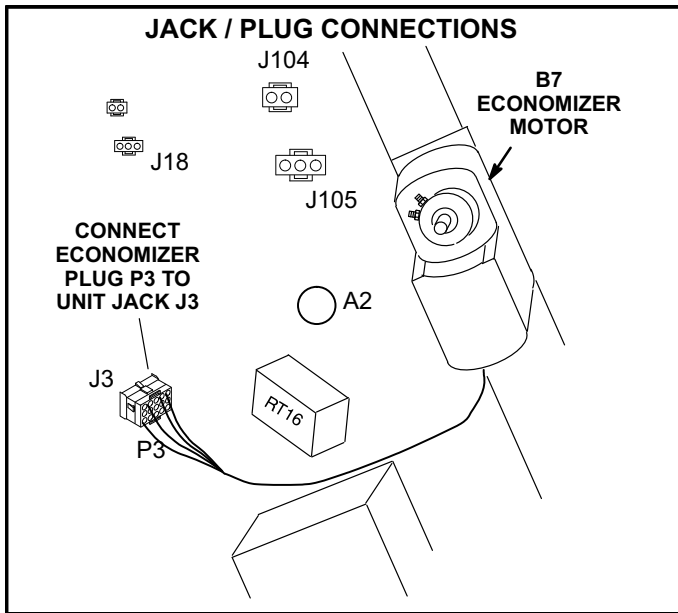

FIGURE 4

Install Economizer - Horizontal

A field fabricated return air duct transition and duct inlet must be installed in horizontal applications. K1HECK, horizontal discharge kit, must be ordered separately.

- 1- Remove unit end panel. See figure 5.
- 2- Install the downflow return air cover in horizontal airflow applications. See instructions provided with K1HECK and figure 5.
- 3- Make sure the horizontal return air cover on the back side of the unit remains in place. The opening is used when an economizer is not installed. See figure 6.

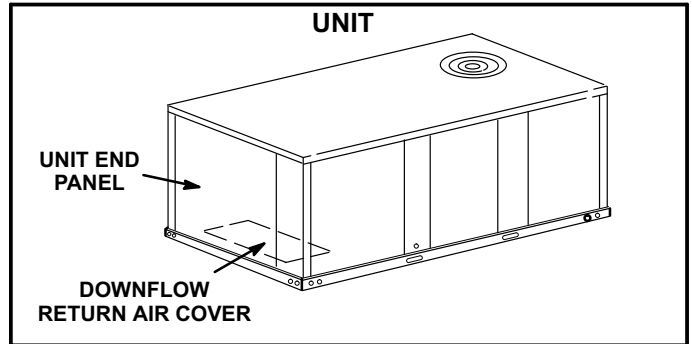

FIGURE 5

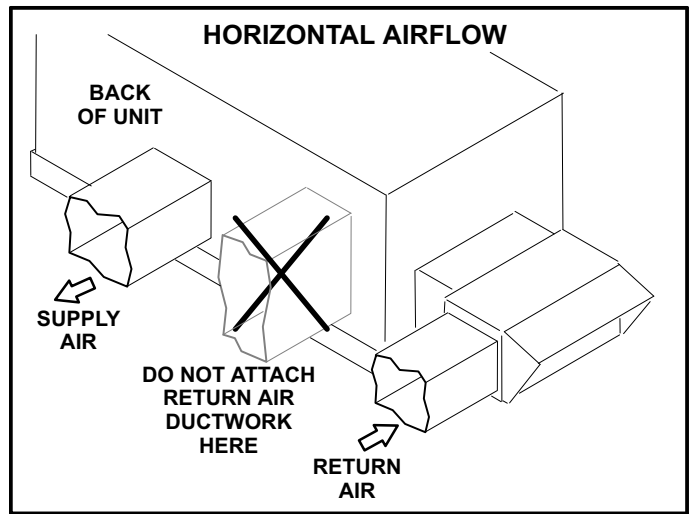

FIGURE 6

- 4- Install the economizer and connect wiring as shown in appropriately named sections of this manual.
- 5- Install the field-fabricated return air duct transition and duct inlet on the unit end. See figure 7. Support the transition and duct inlet as needed.
- 6- Install the upper hood on the unit as shown in appropriate section of this manual.

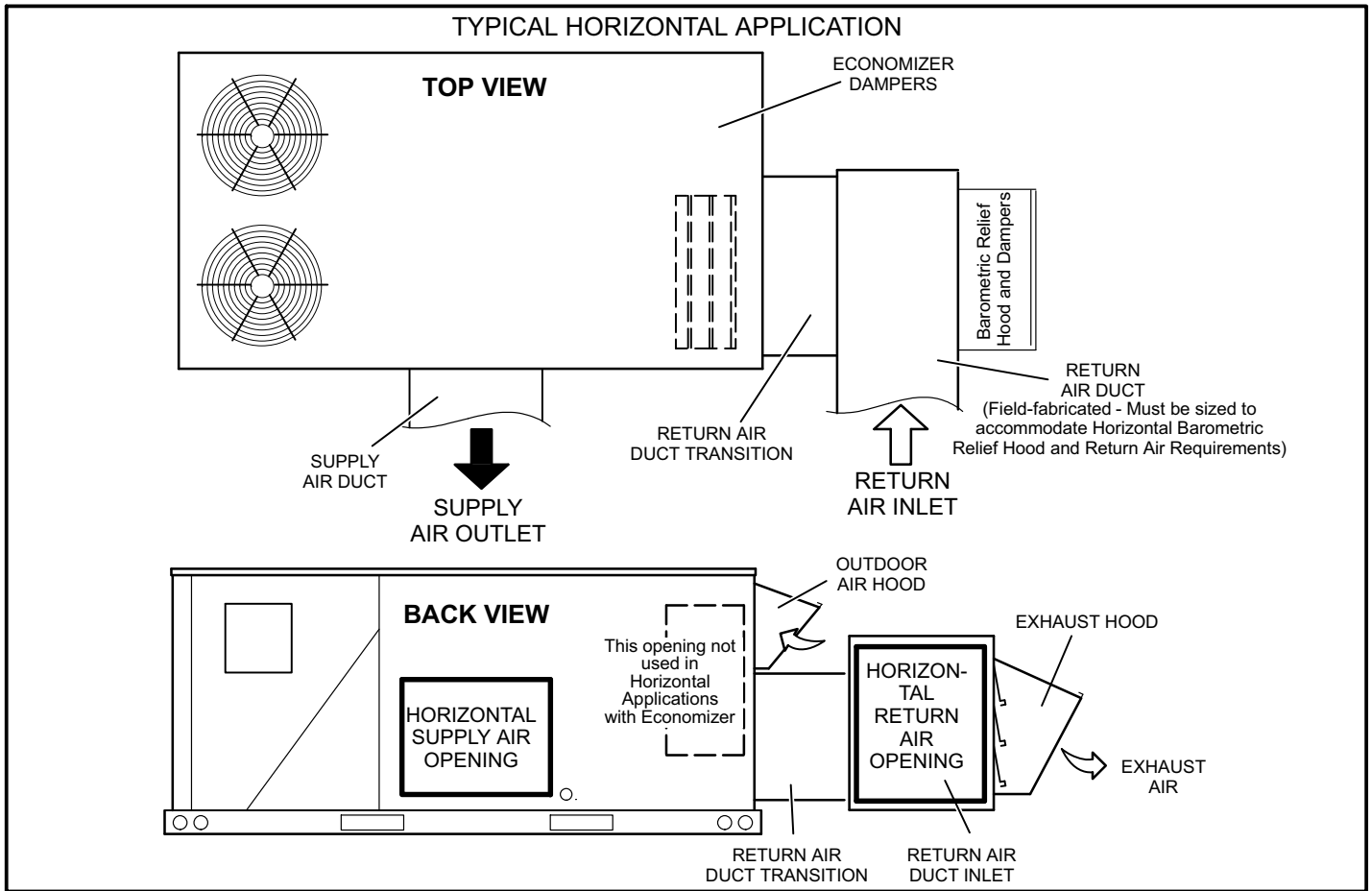

FIGURE 7

Install Gravity Exhaust Damper (GED)

Downflow Application -- GED

- 1- Remove lower accessory compartment access panel (if necessary).
- 2- Apply foam insulating tape around the back of the flanged edges of the GED assembly.

NOTE - When GED is being used with the PEF power exhaust fans, gravity exhaust damper is installed over the outer side of the PEF assembly. See figure 8.

- 3- Align holes along the flanged edge of the GED with holes along the bottom of the unit.
- 4- Use provided screws to secure gravity exhaust assembly to unit.
- 5- Restore power to unit.

Downflow Application --GED Hood Installation

- 1- Attach hood top to hood top support at the top of the damper assembly. See figure 9.
- 2- Remove screws from sides of economizer assembly (if installed). Remove paper backing from foam gaskets on hood sides. Secure left and right hood sides to the damper assembly as shown in figure 9.
- 3- Secure hood top to the hood sides.

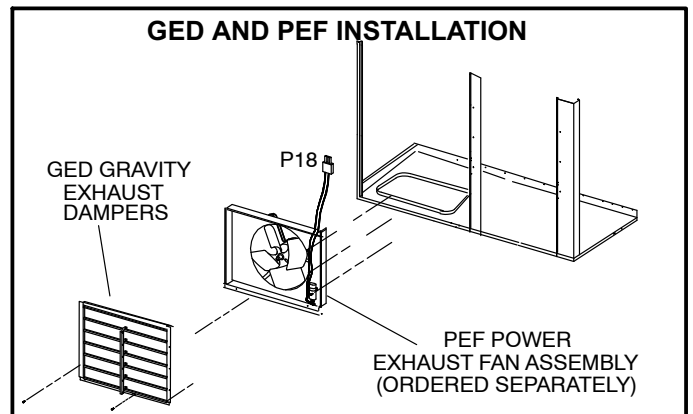

FIGURE 8

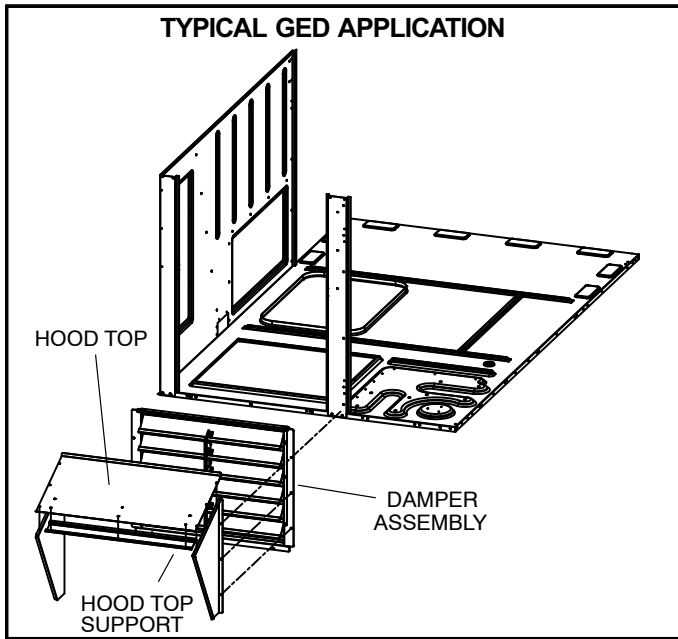

FIGURE 9
Horizontal Application

For horizontal applications, a separately ordered horizontal discharge kit is required. The horizontal, field-fabricated return air duct must be sized to accommodate the gravity exhaust damper and hood shipped with the economizer. A separately ordered low profile gravity exhaust damper (LAGEDH) and hood kit is available for size restricted applications. See figure 10.

- 1- Cut one opening in return air plenum. Make sure opening is centered top to bottom in plenum.
- 2- Secure hood sides to hood top as shown in figure 10.
- 3- Apply foam insulating tape around the back of the flanged edges of the damper assembly.
- 4- Align screw holes on top edges of hood and damper assembly.
- 5- Slide combined damper assembly into plenum opening and secure using screws provided. See figure 10.
- 6- Restore power to unit.

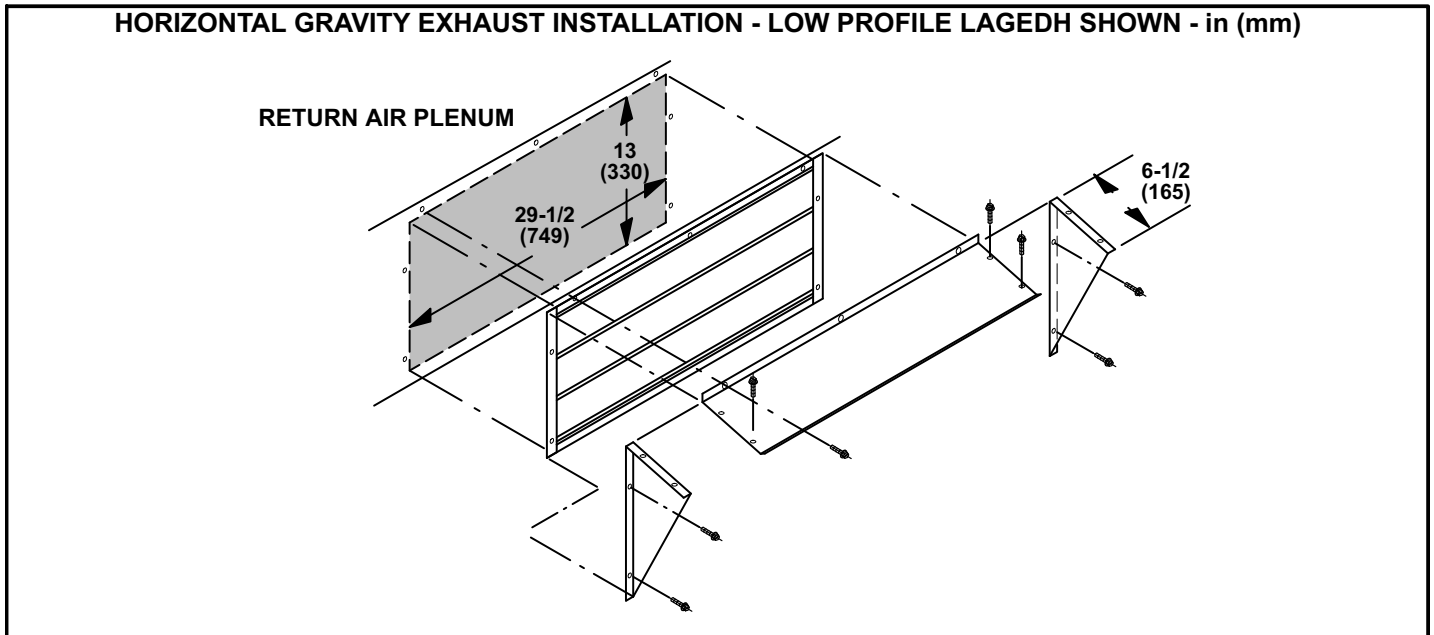

FIGURE 10

Install Outdoor Air Hood

The outdoor air hood is packaged separately and is attached to the economizer assembly crate. Use #10 self-drilling screws to assemble and install hood unless otherwise noted.

- 1- Remove screws which secure unit top panel to accessory compartment cabinet. Lift top panel to install hood top seal.
- 2- Slide hood top seal under unit cabinet top and secure using three of the existing cabinet top panel screws. Install, but do not tighten, the screws on each end of the hood.
- 3- Position the hood top edge V-channel under the corresponding V-channel on hood top seal and slide hood from right to left until it is properly positioned.
- 4- Secure hood left side to the hood top and to the unit cabinet using the provided screws. See figure 11.
- 5- Secure the hood right side to the hood top. Do NOT secure the hood right side to unit.
- 6- Align the two holes on the left hood side with the two holes in the top filter seal bracket. Secure using provided screws.
- 7- Secure top filter seal bracket to the right hood side in the same manner.
- 8- Secure the right hood side to the unit.
- 9- Slide two filters into slot of the bottom filter seal bracket. Insert a filter spacer between the two filters and secure it to the hood top panel. Use the provided threaded hex insert and a #10 - 32 X 1/2" thread forming screw to secure the hood top filter bracket. See figure 12.

NOTE - Slide the filters to the left side of the hood. Make sure there are no air gaps between either two filters or the filter and the hood right side.

Economizer Operation

NOTE - Use indicating lights on the Unit Controller to determine thermostat demand.

See table 2 for economizer operation with a standard two-stage thermostat.

Table 3 shows economizer operation with an energy management system which uses a global sensor.

Table 4 shows economizer operation with in zone sensor mode.

Tables show the occupied and unoccupied time period. The occupied time period is determined by the thermostat or energy management system.

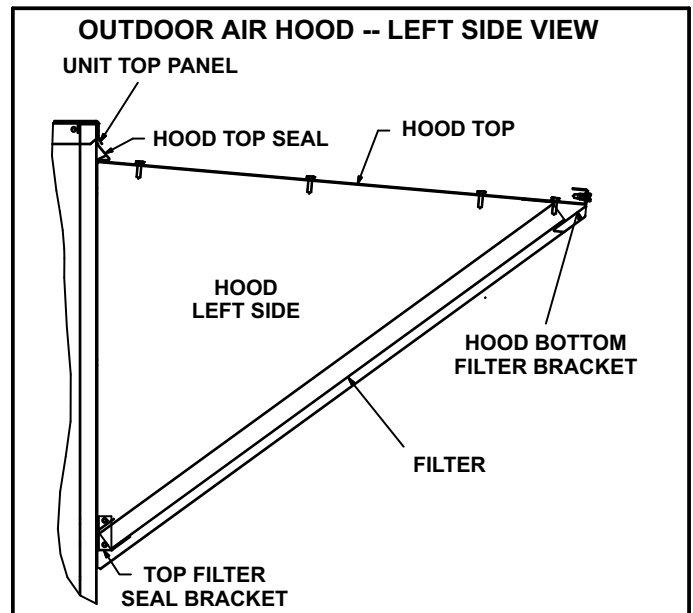

FIGURE 11

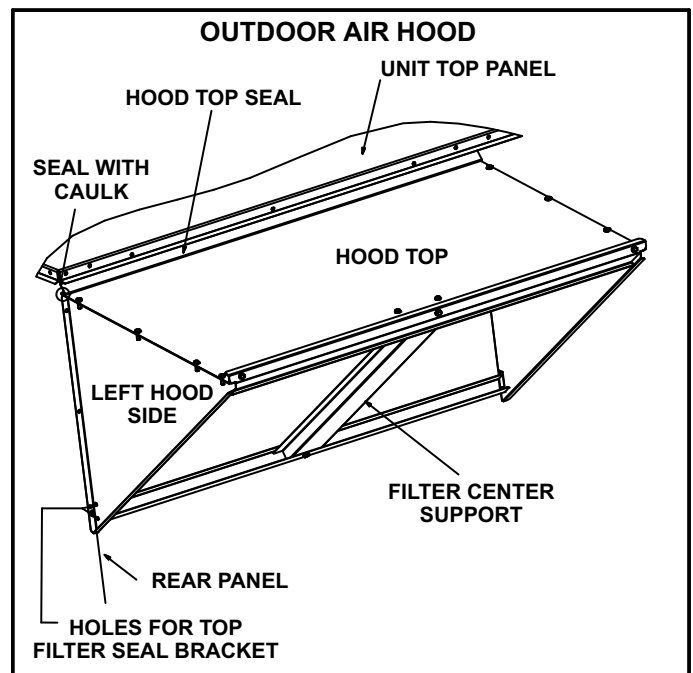

FIGURE 12

IAQ Damper Operation

The Unit Controller has a 0-10VDC IAQ input for a standard 0-2000ppm CO₂ sensor. The economizer starts opening at a CO₂ level of 500 ppm (default) and reaches full open at a CO₂ level of 1000ppm. These levels are adjustable as outlined in the Unit Controller manual under Menu: Settings > Setpoints > IAQ.

If the economizer is operating in the free cooling mode and the IAQ sensor demands more fresh air, the IAQ demand will override the free cooling demand to open the dampers further or to keep them open. A flashing OAS LED on the Unit Controller indicates an IAQ override condition.

The IAQ function is not energized during the unoccupied or night time period.

TABLE 2 ECONOMIZER OPERATION - Standard Two-Stage Thermostat (Default Option)

THERMOSTAT DEMAND	DAMPER POSITION UNOCC.	DAMPER POSITION OCCUPIED	MECHANICAL COOLING
OUTDOOR AIR IS NOT SUITABLE FOR FREE COOLING -- ³ OAS LED "ON"			
OFF	CLOSED	CLOSED	NO
G	CLOSED	MINIMUM	NO
Y1	CLOSED	MINIMUM	STAGE 1
Y2	CLOSED	MINIMUM	STAGES 1 AND 2
OUTDOOR AIR IS SUITABLE FOR FREE COOLING -- ³ OAS LED "ON"			
OFF	CLOSED	CLOSED	NO
G	CLOSED	MINIMUM	NO
Y1	MODULATING	MODULATING	NO
Y2	MODULATING	MODULATING ¹	STAGES 1 AND 2 ²

NOTE - Modulating dampers adjust to control supply air (RT6) to 55°F (13°C). ¹The unit control initiates a "cool down" or "warm-up" mode when the occupied time period starts. ²Units with two-stage compressor operation will operate only stage 1 with a Y2 demand. ³OAS LED on M2 Unit Controllers only.

TABLE 3 ECONOMIZER OPERATION WITH GLOBAL SENSING - Energy Management System (Default Option)

THERMOSTAT DEMAND	DAMPER POSITION UNOCC.	DAMPER POSITION OCCUPIED	MECHANICAL COOLING
GLOBAL INPUT OFF -- ³ OAS LED "ON "			
OFF	CLOSED	CLOSED	NO
G	CLOSED	MINIMUM	NO
Y1	CLOSED	MINIMUM	STAGE 1
Y2	CLOSED	MINIMUM	STAGES 1 AND 2
GLOBAL INPUT ON -- ³ OAS LED "ON "			
OFF	MODULATING	MODULATING	NO
G	MODULATING	MODULATING	NO
Y1	MODULATING	MODULATING	STAGE 1
Y2	MODULATING ¹	MODULATING ¹	STAGES 1 AND 2 ²

NOTE - Modulating dampers adjust to control supply air (RT6) to 55°F (13°C). ¹The Unit Controller initiates a "cool down" or "warm-up" mode when the occupied time period starts. ²Units with two-stage compressor operation will operate only stage 1 with a Y2 demand (default). ³OAS LED on M2 Unit Controllers only.

TABLE 4 ECONOMIZER OPERATION - Zone Sensor Mode

DEMAND	DAMPER POSITION UNOCC.	DAMPER POSITION OCCUPIED	MECHANICAL COOLING
OUTDOOR AIR IS NOT SUITABLE FOR FREE COOLING -- ³ OAS LED "ON"			
OFF	CLOSED	CLOSED	NO
G	CLOSED	MINIMUM	NO
Cooling Stage 1	CLOSED	MINIMUM	COMPRESSOR 1
Cooling Stage 2	CLOSED	MINIMUM	COMPRESSOR 1 & 2
OUTDOOR AIR IS SUITABLE FOR FREE COOLING -- ³ OAS LED "ON"			
OFF	CLOSED	CLOSED	NO
G	CLOSED	MINIMUM	NO
Cooling Stage 1	MODULATING	MODULATING	NO
Cooling Stage 2	FULL OPEN ¹	FULL OPEN ¹	COMPRESSOR 1

NOTE - Modulating dampers adjust to control supply air (RT6) to 55°F (13°C). ¹The Unit Controller initiates a "cool down" or "warm-up" mode when the occupied time period starts. ³OAS LED on M2 Unit Controllers only.

TYPICAL ECONOMIZER WIRING DIAGRAM - STANDARD

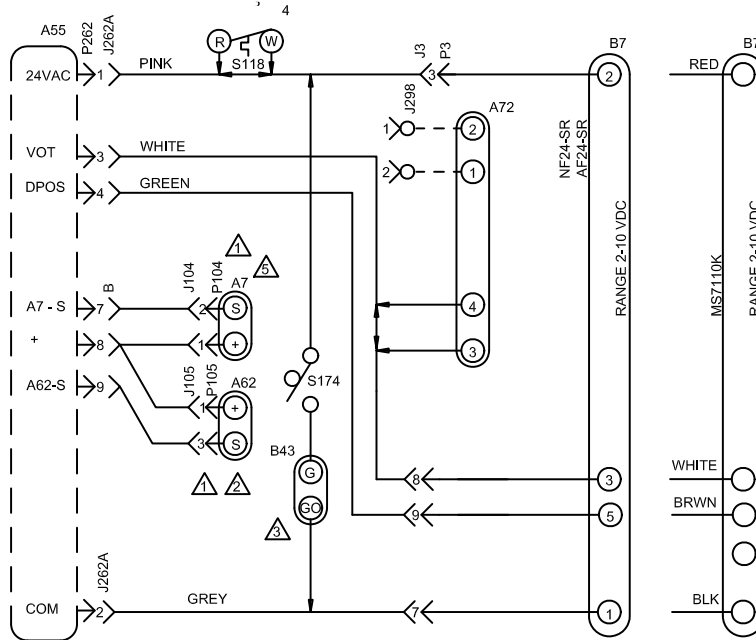

DESCRIPTION	
KEY	COMPONENT
A7	SENSOR, SOLID STATE ENTHALPY
A130	CONTROL, ERS
A55	CONTROL, MAIN PANEL LENNOX
A62	SENSOR, ENTHALPY INDOOR
A72	CONTROL, REMOTE MIN POS (OPT)
B7	MOTOR, DAMPER ECONOMIZER
B43	MOTOR, EXHAUST DAMPER
J3	JACK, UNIT ECONOMIZER
J104	JACK, SENSOR OUTDOOR ENTHALPY
J105	JACK, SENSOR RETURN AIR ENTHALPY
J153	JACK, ENTHALPY / DAMPER MOTOR
J193	JACK, ENTHALPY SENSOR
J298A	JACK, IAQ INTERFACE
J262A	JACK, DAMPER MOTOR
J262B	JACK, ENTHALPY SENSORS
P3	PLUG, ECONOMIZER BYPASS
P153	PLUG, ENTHALPY / DAMPER MOTOR
P193	PLUG, ENTHALPY SENSOR
P262	PLUG, ECONOMIZER OUTPUT
S118	THERMOSTAT, DESICANT DEFROST
S174	SWITCH, EXHAUST DAMPER

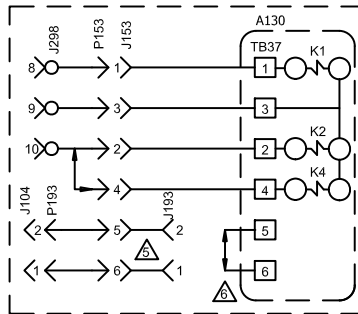

ENERGY RECOVERY WHEEL HOOK UP

NOTE- THIS DIAGRAM USED ONLY WHEN ECONOMIZER OR MOTORIZED OUTDOOR AIR DAMPERS ARE INSTALLED.

————— DESIGNATES OPTIONAL WIRING
 - - - - - CLASS II FIELD WIRING

- ⚠️ DELETE A7 AND A62 (IF USED) FOR EITHER GLOBAL ENTHALPY OR SENSIBLE TEMPERATURE CONTROL
- ⚠️ FOR UNIT DIFFERENTIAL ENTHALPY CONTROL, ADD A62 RETURN AIR ENTHALPY SENSOR
- ⚠️ OPTIONAL EXHAUST DAMPER ACTUATOR TO HOLD EXHAUST DAMPER CLOSED WHEN OUTSIDE AIR DAMPER IS CLOSED
- ⚠️ S118 USED ON 35 TO 50 TON EMERGENCY UNITS WITH ENERGY RECOVERY WHEEL (ERW)
- ⚠️ REPOSITION A7 ENTHALPY SENSOR FROM ROOFTOP UNIT ECONOMIZER INTO INTAKE HOOD OF THE ERW ROOFTOP UNIT
- ⚠️ REMOVE JUMPER WHEN INSTALLING OPTIONAL LOW AMBIENT SWITCH

Economizer Start-Up - M2 Unit Controller

The unit will be equipped with either an M2 or M3 Unit Controller. M2 or M3 will be printed on the bottom of the Unit Controller near the SBUS connector. Use the appropriate start-up section in this manual and refer to the Unit Controller provided with the rooftop unit. Application manuals are available for both Unit Controllers.

The economizer is controlled by the Unit Controller which is located in the unit control panel. A detailed menu layout can be found in the Unit Controller manual provided with each unit.

A-Field-Installed Economizer

The Unit Controller must be set to identify an economizer has been installed.

- 1- Use the Unit Controller keypad to enter the following menu:
Setting / Install / Damper
- 2- Use the up/down arrows to display ECON and press the SELECT button (!SET! will display).
- 3- Press the left arrow returning up the menu path until the Unit Controller resets and saves the change.

The Unit Controller will now operate the economizer.

B-Free Cooling Mode and Setpoint

On start-up, the economizer mode defaults to TEMP OFFSET. In this mode, free cooling is energized when the outdoor air temperature (RT17) is less than return air temperature (RT16) by at least the offset value. The default offset value is 10°F. Use the following menu path on the Unit Controller to adjust the free cooling mode or setpoint. See figure 14 for sensor location.

Settings / Setpoints / Damper / Economizer Mode

Refer to table 5 and figure 13 for additional free cooling modes and setpoints. The Unit Controller has a restricted range of input values for each mode as shown in table 5.

Note - An energy management system may be used to provide the outdoor air suitable (OAS) signal via network connection. The free cooling mode must be set to one of the TEMP modes to allow this function.

C-Free Cooling Setpoint - California Title 24 Compliance

For California Title 24 compliance, adjust the free cooling setpoint based on:

- The climate zone where the unit is installed. See table 6.
- The setpoint requirement published by the California Energy Commission. See Section 140.4 - Prescriptive Requirements for Space Conditioning Systems of the 2013 Building Energy Efficiency Standards.

Note - Values in the referenced standard will supersede values listed in table 6.

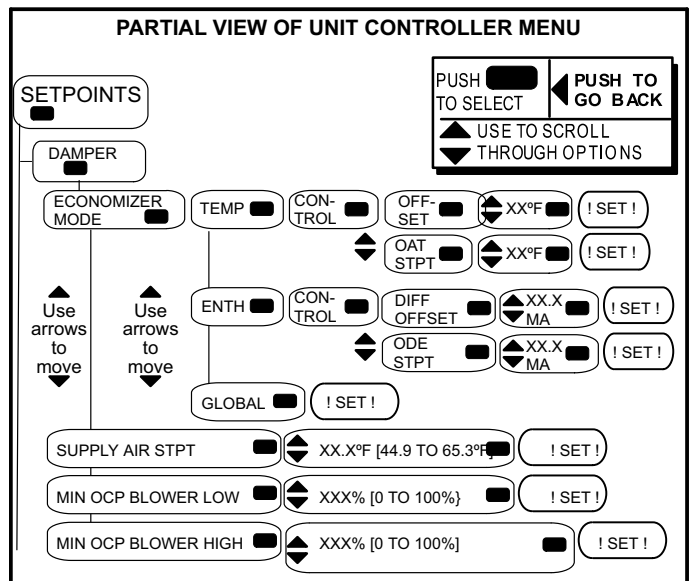

FIGURE 13

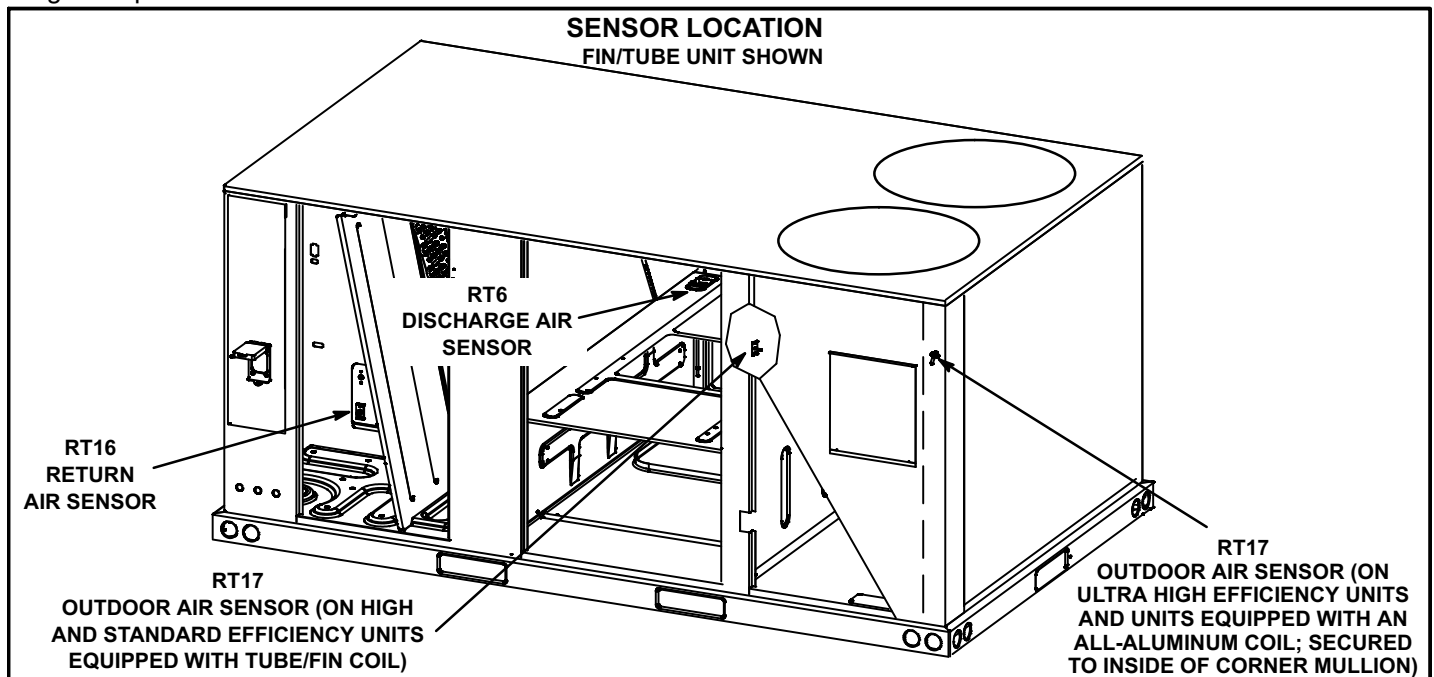

FIGURE 14

**TABLE 5
ECONOMIZER MODES AND SETPOINT**

Free Cooling Mode	Free Cooling Setpoint	Field-Provided Sensors	Dampers will modulate to 55°F discharge air (RT6) when outdoor air is suitable:	Permitted Inputs
TEMP	OFFSET	None Needed	Outdoor air temperature (RT17) is less than return air temperature (RT16) by at least the OFFSET value.	0-40°F
TEMP	OAT STPT	None Needed	Outdoor air temperature (RT17) is less than the OAT STPT value.	41-75°F
Remote	Remote	Energy Management System**	Either of the TEMP modes can be used when a network OAS signal is provided by an energy management or building control system, via BACnet, LonTalk, or L Connection. The network can command OAS, NOT OAS, or AUTO. AUTO returns to local control of OAS, which is the selected TEMP mode.	NA
ENTH	DIFF OFFSET	(Two) C7400	Outdoor air enthalpy* (A7) is less than return air enthalpy (A62) by at least the OFFSET value.	0mA-4mA
ENTH	ODE STPT	C7400	Outdoor air enthalpy (A7) is less than free cooling setpoint.	12-19mA
GLOBAL	GLOBAL	24VAC Input Signal	Global input is energized by (P297-9). This setting is also used for outdoor air damper applications. Global input also brings on the blower. (This mode is NOT used when OAS signal is provided via network connection. GLO is only used when a 24VAC signal is used to energize the P297-9 GLO input.)	NA

*Enthalpy includes effects of both temperature and humidity.

**Energy management system may require additional field-provided sensors; refer to manufacturer's instructions.

**TABLE 6
TITLE 24 FREE COOLING SETPOINT**

Climate Zone	Setpoint (Single Sensible)	Setpoint (Differential Sensible)
1, 3, 5, 11-16	75°F	0°F
2, 4, 10	73°F	2°F
6, 8, 9	71°F	4°F
7	69°F	6°F

D-Setting Free Cooling Setpoint in Enthalpy Mode

Free Cooling Setpoint - ODE STPT

The enthalpy sensor (A7) provides a milliamp signal to the Unit Controller based on outdoor air temperature and humidity. See table 7. To set a free cooling setpoint of 73°F at 50% relative humidity, enter "12" at the ODE STPT menu prompt. The Unit Controller will allow dampers to modulate open at approximately 73°F. If the space temperature is too warm, change the ODE STPT to "13.6" and the Unit Controller will allow dampers to modulate open at approximately 70°F.

**TABLE 7
FREE COOLING SETPOINT - ODE STPT OR
ECONOMIZER ENTHALPY SETPOINT MODE**

Enthalpy Setpoint °F (°C)*	Menu Entry - mA	Counts
73 (23)	12.0	150
70 (21)	13.6	173
67 (19)	15.5	199
63 (17)	17.6	224

*Approximate temperature at 50% relative humidity.

Free Cooling Differential Enthalpy - DIFF OFFSET

The Unit Controller allows damper modulation when outdoor air is lower than return air by a differential or offset temperature and humidity range. To set an offset range of 7°F at a constant relative humidity, enter "4" at the DIFF OFFSET menu prompt. If return air is 76°F, the Unit Controller will allow damper to modulate open at approximately 69°F outdoor air. See table 8. If the space temperature is too cool or dry, change the DIFF OFFSET to "3" and the Unit Controller will allow dampers to modulate open at approximately 71°F outdoor air.

**TABLE 8
FREE COOLING SETPOINT - DIFF OFFSET OR
ECONOMIZER ENTHALPY OFFSET MODE**

*Temperature Offset °F	**Relative Humidity Offset %	Menu Entry mA	Counts
2	6	1	13
3.5	12	2	26
5.3	18	3	39
7	24	4	53

*At a constant relative humidity. **At a constant temperature.

E-Damper Minimum Position Setting

Use the menu path in figure 13 to set the minimum % open damper position when outdoor air is not suitable for free cooling. The minimum setpoint range is 0% open (dampers closed) to 100% (dampers fully open). On units with staged supply air blowers, refer to the unit installation instructions.

**TABLE 9
FREE COOLING OPTIONS**

Config ID1 POS 2)	Unit Controller Input (Mode)	M3 Display (Free Cooling Options)	Default Setting	Range Setting	Outdoor air is suitable for free cooling when:
T	Differential Sensible Sensor (default mode)	ECONOMIZER TEMP ECON TYPE = TEMPERATURE OFFSET	10°F	0°F - 40°F	Outdoor air temperature (RT17) is less than return air temperature (RT16) by at least the offset value.
T	Single Sensible Sensor	ECONOMIZER TEMP ECON TYPE = TEMPERATURE SETPOINT	75°F	40 F - 75 F	Outdoor air temperature (RT17) is less than the Outdoor Air Temperature set point value.
T	Network OAS	ECONOMIZER TEMP ECON TYPE = TEMPER- ATURE OFFSET or SETPOINT	Not Applicable	Not Applicable	Either of the TEMP modes (set point or offset) can be used when a network OAS signal is provided by an energy management or building control system, via BACnet, LonTalk, or L Connection. The network can command OAS, NOT OAS, or AUTO. AUTO returns to local control of OAS, which is the selected TEMP mode.
S	Single Enthalpy* Sensor	ECONOMIZER ENTHALPY SETPOINT = 12.0 MA	12.0 mA	10mA - 19 mA	Outdoor air enthalpy (A7) is less than enthalpy set point parameter.
D	Differential En- thalpy* Sensor	ECONOMIZER ENTHALPY OFFSET = 1.0 MA	1.0 mA	1 mA - 5 mA	Outdoor air enthalpy* (A7) is less than return air enthalpy (A62) by at least the OFFSET value.
G	Global	Mode and setpoint are not set by Unit Controller. Menu advances to: FREE COOLING SUPPLY AIR SETPOINT = 55°F	Not Applicable	Not Applicable	Global input is energized by (P297-9). This setting is also used for outdoor air damper applications. Global input also brings on the blower. (This mode is NOT used when OAS signal is provided via network connection. GLO is only used when a 24VAC signal is used to energize the P297-9 GLO input.)

*Enthalpy includes effects of both temperature and humidity.

Economizer Start-Up - M3 Unit Controller

The unit will be equipped with either an M2 or M3 Unit Controller. M2 or M3 will be printed on the bottom of the Unit Controller near the SBUS connector. Use the appropriate start-up section in this manual and refer to the Unit Controller provided with the rooftop unit. Application manuals are available for both Unit Controllers.

The economizer is controlled by the Unit Controller which is located on the unit control panel. A detailed menu layout can be found in the Unit Controller manual provided with each unit.

A-Field-Installed Economizer

The Unit Controller must be set to identify an economizer has been installed. The configuration ID will also identify which sensor inputs the Unit Controller will use to determine the free cooling mode. See figure 14 for sensor location.

1- Use the Unit Controller keypad to enter the following menu:

MAIN MENU > SETUP > INSTALL

2- Press SAVE until CONFIGURATION ID 1 appears. Change the second character in the configuration ID to identify the type of input used to determine economizer free cooling setpoint. See table 9.

- 3- Press SAVE. The Unit Controller is now set up to operate the economizer.
- 4- Press the MAIN MENU button, then the BACK button, to display the status screen.

B-Adjust Free Cooling Discharge Air Setpoint

When outdoor air is suitable for free cooling, dampers will modulate to maintain a discharge air temperature of 55°F default (adjustable range 45°-67°F). Refer to RT6 discharge air sensor location shown in figure 14.

**TABLE 10
DAMPER OPTIONS**

Level 2	Level 3	Level 4	Level 5
RTU OP- TION	DAMPER	ECONOMIZER ENTHALPY OFFSET = 12.0 MA	
		ECONOMIZER ENTHALPY SETPOINT = 1.0 MA	
		ECONOMIZER TEMP ECON TYPE = TEMPERATURE OFFSET OR TEMPERATURE SETPT	
		ECONOMIZER OAT SETPOINT = XX.X F	
		FREE COOLING SUPPLY AIR SETPOINT = 55°F	
		MIN DAMPER POSITION BLOWER ON HIGH = X.X %	
		MIN DAMPER POSITION BLOWER ON LOW = X.X %	

Note - Menu options vary depending on hardware configuration.

Note - Use the "Adjust and set values" arrows to scroll up or down for selection options.

C-Free Cooling Modes

The Unit Controller automatically sets the free cooling mode when the configuration ID is entered. The temperature setpoint mode is the only exception.

- 1- Use the following menu path on the Unit Controller to enter the temperature setpoint mode.

MAIN MENU > SETTINGS > RTU OPTIONS > DAMPER > ECONOMIZER TEMP ECON TYPE = TEMPERATURE OFFSET (default)

- 2- Use the “Adjust and set values” arrows on the keypad to select TEMPERATURE SETPT.
- 3- Press SAVE.

Note - Network OAS signal and California Title 24 Compliance options use either TEMPERATURE OFFSET or TEMPERATURE SETPT mode.

D-Adjust Outdoor Air Free Cooling Setpoint

Note - Configuration ID 1 must be set to the appropriate mode before adjusting the free cooling setpoint. See table 9

Temperature Offset or Temperature Setpoint Mode

- 1- After the free cooling mode is saved, if default setpoint value needs to change, enter the new number and press SAVE.
- 2- For *California Title 24* compliance, adjust the free cooling setpoint based on:
 - The climate zone where the unit is installed. See table 6.
 - The setpoint requirement published by the California Energy Commission. See *Section 140.4 - Prescriptive Requirements for Space Conditioning Systems of the 2013 Building Energy Efficiency Standards*.

Note - Values in the referenced standard will supersede values listed in table 6.

- 3- When a network OAS signal is provided by a building control system, refer to control system literature to adjust free cooling setpoint.

Enthalpy Setpoint

The enthalpy sensor (A7) provides a milliamp signal to the Unit Controller based on outdoor air temperature and humidity. Use the following menu to change the setpoint:

MAIN MENU > SETTINGS > RTU OPTIONS > DAMPER > ECONOMIZER ENTHALPY SETPOINT = 12.0 MA

Refer to table 7. At 12.0mA, the Unit Controller will allow dampers to modulate open at approximately 73°F. If the space temperature is too warm or humid, change the ECONOMIZER ENTHALPY SETPOINT to “13.6MA” and the Unit Controller will allow dampers to modulate open at approximately 70°F.

Enthalpy Offset

The Unit Controller allows damper modulation when outdoor air is lower than return air by a differential or offset temperature and humidity range. Use the following menu to change the setpoint:

MAIN MENU > SETTINGS > RTU OPTIONS > DAMPER > ECONOMIZER ENTHALPY OFFSET = 1.0 MA

Refer to table 8. At 1.0mA, the Unit Controller will allow dampers to modulate open when outdoor air is lower than return air by approximately a 2°F offset. If return air is 76°F, the Unit Controller will allow dampers to modulate open at approximately 74°F. If the space temperature is too warm or humid, change the ECONOMIZER ENTHALPY SETPOINT to 2.0mA or an offset of 3.5°F. The Unit Controller will allow dampers to modulate open at approximately 72.5°F.

E-Damper Minimum Position Setting

Use the menu path in table 10 to set the MIN DAMPER POSITION BLOWER ON HIGH when outdoor air is not suitable for free cooling. The minimum setpoint range is 0% open (dampers closed) to 100% (dampers fully open). On units with staged supply air blowers, also set the MIN DAMPER POSITION BLOWER ON LOW.