

INSTALLATION INSTRUCTIONS FOR ENTHALPY SENSOR KIT (603364-29; 11G21) USED WITH HIGH PERFORMANCE ECONOMIZERS ON ZG/ZC/ZH 036, 048, 060, 072 AND TAA UNITS

Shipping and Packing List

Package 1 of 1 contains:

- 1- Temperature & humidity sensor
- 1- Wiring harness (used for differential sensing only)
- 1- Bag assembly containing:
 - 2-#10-16 X 5/8" SDST screws

Check packaging for shipping damage. Contact the last carrier immediately if any shipping damage is found.

⚠ WARNING

Improper installation, adjustment, alteration, service or maintenance can cause property damage, personal injury or loss of life. Installation and service must be performed by a licensed professional HVAC installer or equivalent, service agency, or the gas supplier

Application

Sensors provide input to determine free cooling suitability. The enthalpy sensor provided in this kit senses both sensible temperature and humidity. See table 1- for usage.

Refer to economizer installation instructions.

Note - Differential sensor applications must use the same two sensors.

TABLE 1-

Sensors	Dampers modulate to maintain 55°F mixed air (R1) when:
Single OA Enthalpy Not approved for CA Title 24	OA temperature and humidity (A7) is lower than free cooling setpoint.
Differential Enthalpy - 1 in OA & 1 in RA Not approved for CA Title 24	OA temperature and humidity (A7) is lower than RA temperature and humidity (A62).

⚠ CAUTION

Danger of sharp metallic edges. Can cause injury. Take care when servicing unit to avoid accidental contact with sharp edges.

ZG/ZC/ZH - Single Enthalpy

Note - Install the return air sensor before installing optional power exhaust dampers and gravity exhaust dampers. If gravity exhaust, power exhaust, or hoods are already installed, remove from unit.

- 1- Disconnect all power to unit.
- 2- Remove filter access panel and return air access panel. If hood is already installed, remove hood. See figure 1.
- 3- Set the DIP switch on kit sensor to appropriate "OA" setting as indicated on sensor.
- 4- Replace existing RT26 OA sensor with new A7 sensor from this kit. See figure 2 for sensor location.
- 5- On A6 economizer control, remove orange wires going to terminals marked "OAT" and reconnect them to free terminals marked "S-BUS". Discard harness provided in kit. See figure 3.
- 6- Follow economizer installation instruction for setup.

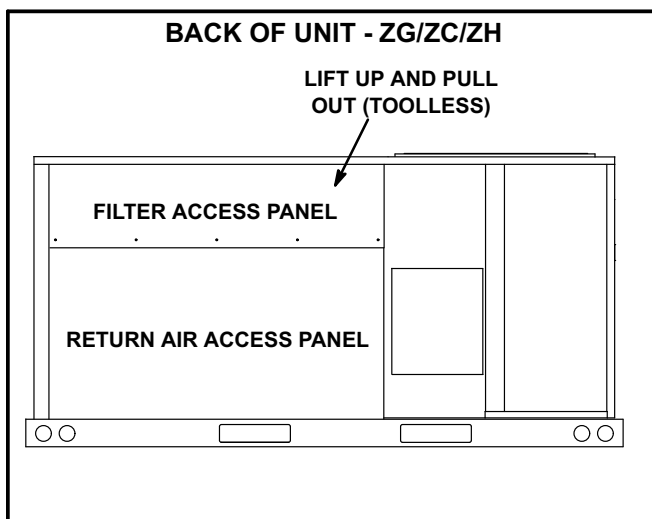

FIGURE 1



ZG/ZC/ZH - Differential Enthalpy

Note - Install the return air sensor before installing optional power exhaust dampers and gravity exhaust dampers. If gravity exhaust, power exhaust, or hoods are already installed, remove from unit.

- 1- Disconnect all power to unit.
- 2- Remove filter access and return air access panel. If hood is already installed, remove hood.
- 3- Set the DIP switch on one kit sensor to "OA" setting and the second kit sensor to "RA" setting as indicated on the sensor.
- 4- Replace existing RT26 OA sensor with new A7 kit sensor set to "OA". See figure 2 for sensor location.
- 5- On A6 economizer control, remove orange wires going to terminals marked "OAT" and reconnect them to free terminals marked "S-BUS". See figure 3.
- 6- Install new sensor from second kit as A62 RA sensor in the return air with screws provided. Be sure not to obstruct the damper movement and not to damage wires.
- 7- Connect harness from EITHER kit between the A62 RA sensor and free "S-BUS" terminals on the A6 economizer control. Be sure to route wires away from moving parts. Discard second harness.
- 8- Follow economizer installation instruction for setup.

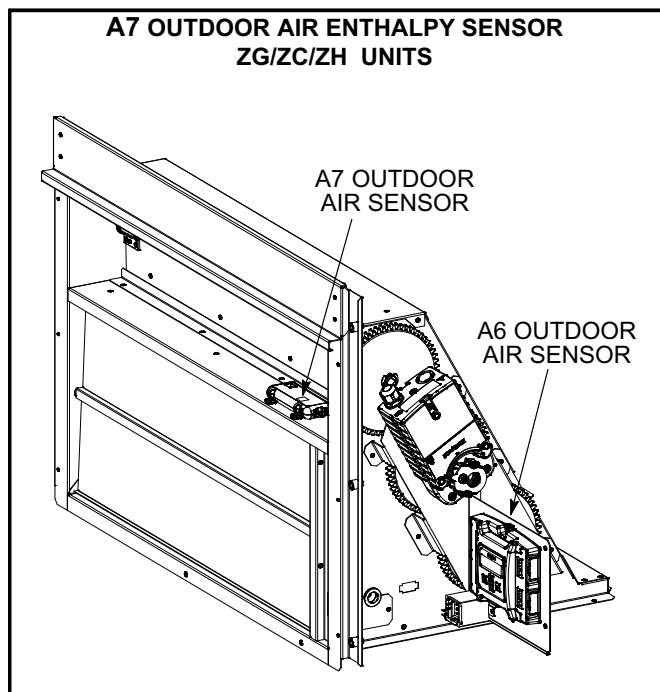

FIGURE 2

TAA - Single Enthalpy

- 1- Disconnect all power to unit.
- 2- Set the DIP switch on kit sensor to appropriate "OA" setting as indicated on sensor.
- 3- Replace existing RT26 OA sensor, if applicable, and replace with new A7 sensor from this kit. See figure 4 for sensor location.
- 4- Remove economizer control access panel. See figure 4.
- 5- On A6 economizer control, remove orange wires going to terminals marked "OAT" and reconnect them to free terminals marked "S-BUS". Discard harness provided in kit. See figure 3.
- 6- Follow economizer installation instruction for setup.

TAA - Differential Enthalpy

- 1- Disconnect all power to unit.
- 2- Set the DIP switch on one kit sensor to "OA" setting and the second kit sensor to "RA" setting as indicated on the sensor.
- 3- Replace existing RT26 OA sensor with new A7 kit sensor set to "OA". See figure 4 for sensor location.
- 4- Remove economizer control access panel. See figure 4.
- 5- On A6 economizer control, remove orange wires going to terminals marked "OAT" and reconnect them to free terminals marked "S-BUS". See figure 4.
- 6- Install new sensor from second kit as A62 RA sensor in the return air with screws provided. Be sure not to obstruct the damper movement and not to damage wires.
- 7- Connect harness from EITHER kit between the A62 RA sensor and free "S-BUS" terminals on the A6 economizer control. Be sure to route wires away from moving parts. Discard second harness.
- 8- Follow economizer installation instruction for setup.

WIRE CONNECTIONS - HIGH PERFORMANCE ECONOMIZERS

Field-Installed - - - -

SINGLE SENSIBLE SENSING (EXISTING)



SINGLE ENTHALPY SENSING

- 1- Replace RT26 with A7.
- 2- Move wiring on A6 controller as shown. Discard harness provided in optional sensor kit.
- 3- Set DIP switch on A7 to appropriate setting "OA".

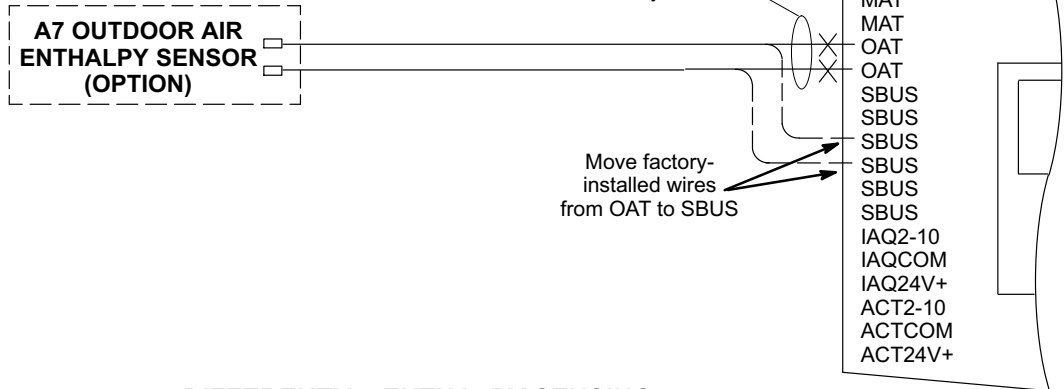

DIFFERENTIAL ENTHALPY SENSING

- 1- Set DIP switch on A7 to appropriate setting "OA". Set DIP switch on A62 to "RA".

Factory-Installed RT26 -

- 1- Two optional enthalpy sensor kits are required. Replace RT26 with A7 from first optional sensor kit.
- 2- Move wiring on controller A6 as shown. Discard harness provided in first optional sensor kit.
- 3- Install second optional sensor (A62) kit using harness provided in second kit.

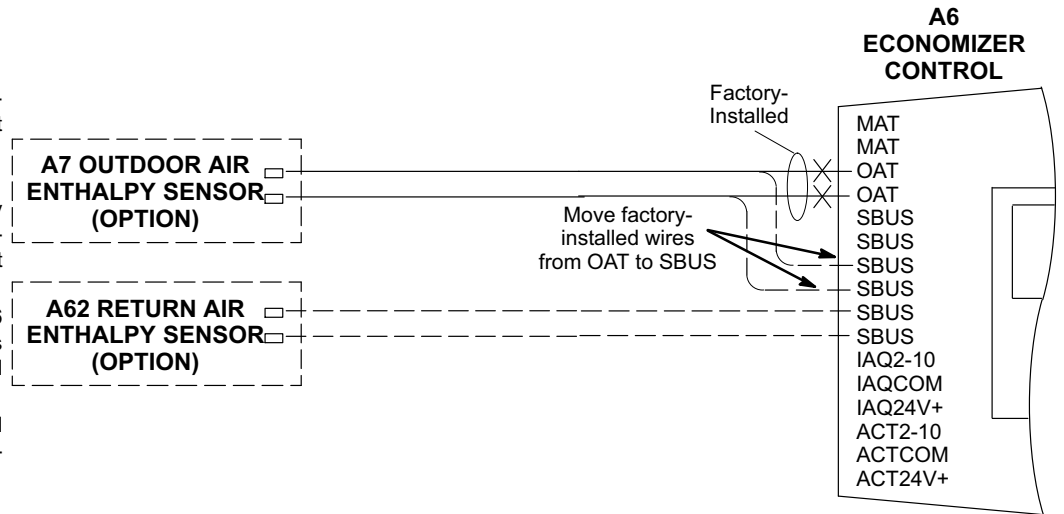
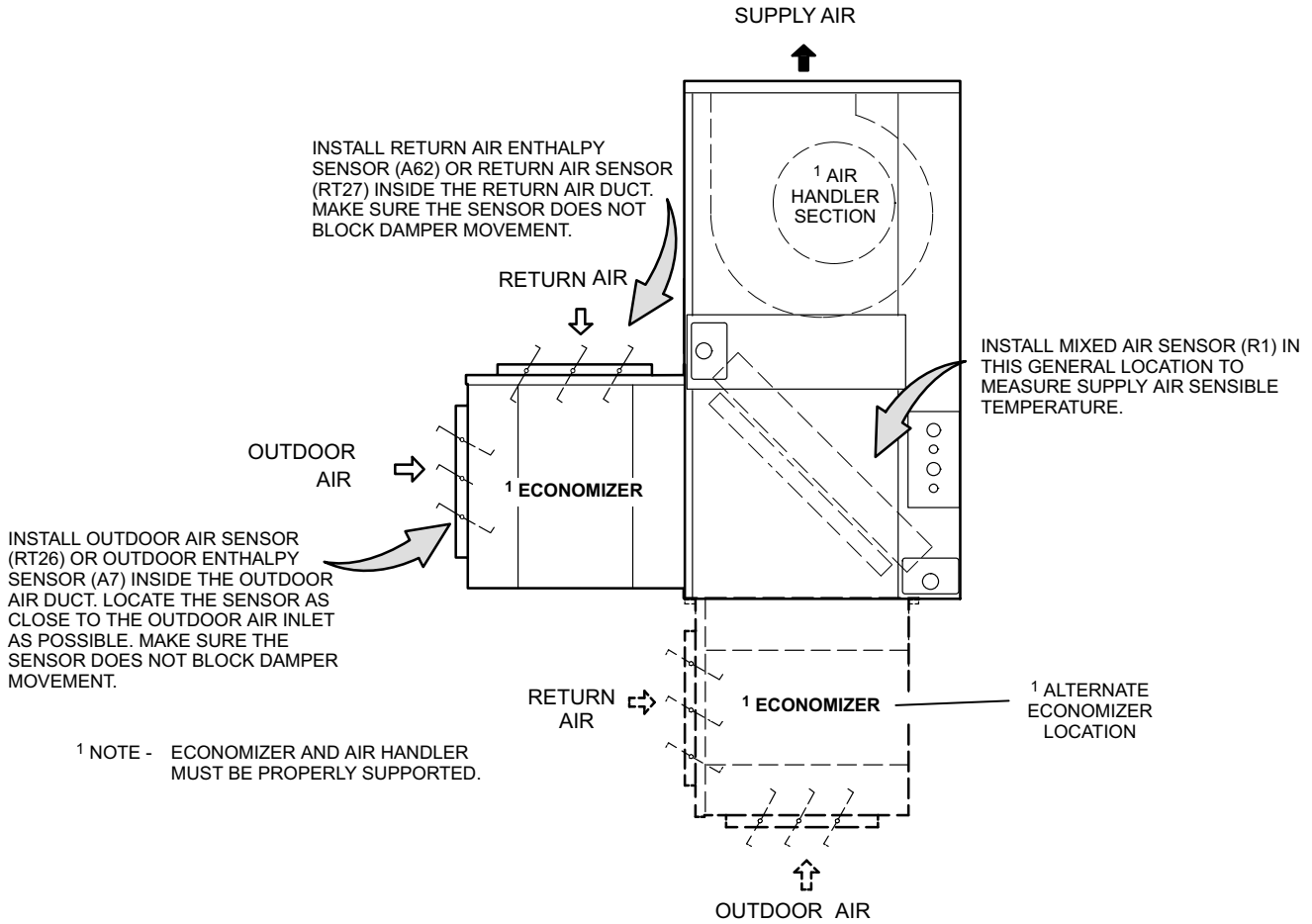

FIGURE 3

TAA UPFLOW UNITS



TAA HORIZONTAL UNITS

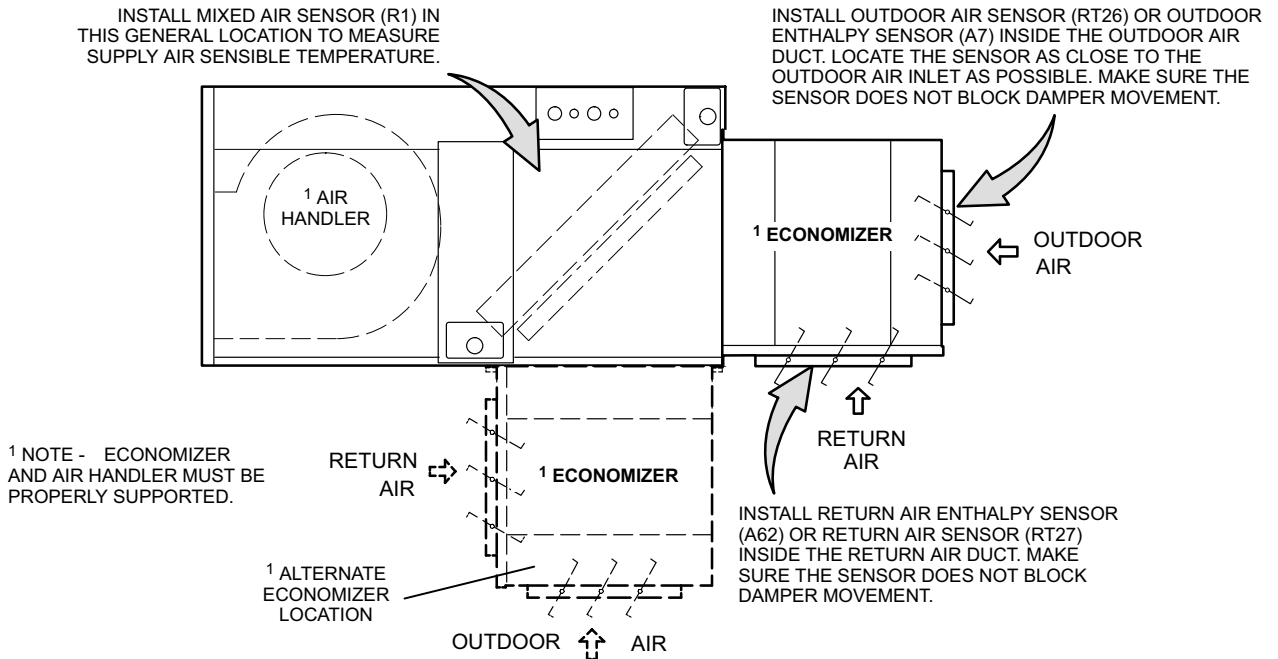

FIGURE 4