

## HIGH ALTITUDE KIT

### INSTALLATION INSTRUCTIONS FOR HIGH ALTITUDE LP/PROPANE KIT 11K44 USED WITH ML180, EL180, 80AF1, ML193, ML195, EL195, 92AF1 & 95AF1 SERIES UNITS

#### **⚠ WARNING**

This conversion kit is to be installed by a licensed professional service technician (or equivalent) or other qualified agency in accordance with the manufacturer's instructions, all codes and requirements of the authority having jurisdiction in the USA, and the requirements of the CSA-B149 installation codes in Canada. If the information in these instructions is not followed exactly, a fire or explosion may result causing property damage, personal injury or loss of life. The qualified agency performing this work assumes responsibility for this conversion.

#### Shipping & Packing List

Package 1 of 1 contains the following:

- 12 -Main burner orifices (0.032)
- 1 - Gas converter sticker
- 1 - Nameplate conversion sticker
- 1 - Bag assembly containing:
  - 1- Gas valve regulator spring
  - 1- Low gas inlet pressure switch (S145)
  - 1- Gas valve inlet brass fitting
  - 1- Wiring harness

#### Application

Use gas conversion kit 11K44 to convert ML180, EL180, 80AF1, ML193, ML195, EL195, 92AF1 & 95AF1 units from natural gas to LP/Propane for applications at altitudes from 7501 - 10,000 ft. Some units may require a pressure switch change, which is ordered separately. See unit installation instruction.

#### Installation

#### **⚠ CAUTION**

As with any mechanical equipment, personal injury can result from contact with sharp sheet metal edges. Be careful when you handle this equipment.

#### **⚠ CAUTION**

Gas valve conversion kit **MUST** be installed **BEFORE** the unit is fired using LP/propane gas. Unit damage **WILL OCCUR** if the unit is fired using LP/propane gas with the original natural gas orifices.

- 1 - Set the thermostat to the lowest setting. If the gas supply line has been connected, shut off the gas supply to the furnace, then disconnect the electrical power.
- 2 - Remove the heating compartment access panel. Turn the automatic gas valve switch to the **OFF** position. See figures 4 and 6.
- 3 - Disconnect the gas supply and the two wires at the gas valve.
- 4 - Remove the burner box cover (if equipped) and set aside. Remove the four manifold securing screws. Slide the manifold/gas valve assembly out of the burner box.
- 5 - Replace the burner orifices with the provided gas orifices. Torque to approximately 35 in-lbs. **Do not** use sealant on orifices. Figures 3 and 2 shows manifold/gas valve assembly.

#### **⚠ IMPORTANT**

**DO NOT** use pipe dope or any pipe sealant on gas orifice threads.

- 6 - Replace the gas valve regulator spring. See figure 7.
  - 7 - **ML180(X), EL180(X) and 80AF1(X) NO<sub>x</sub> units being converted from natural to LP /Propane.**
    - a - Remove the burner box assembly from the vestibule panel.
    - b - Remove the screw which secures each of the NO<sub>x</sub> inserts to the clamshell. **Remove the NO<sub>x</sub> inserts and reinstall the screw. See figure 1.**
    - c - Re-install the burner box assembly.
- NOTE** - When converting unit from LP/Propane back to use with natural gas, the original NO<sub>x</sub> inserts must be reinstalled. Secure the original inserts if available, using the original screws that were re-installed in the vestibule panel. If the original inserts are not available, order replacement kit (70W15).

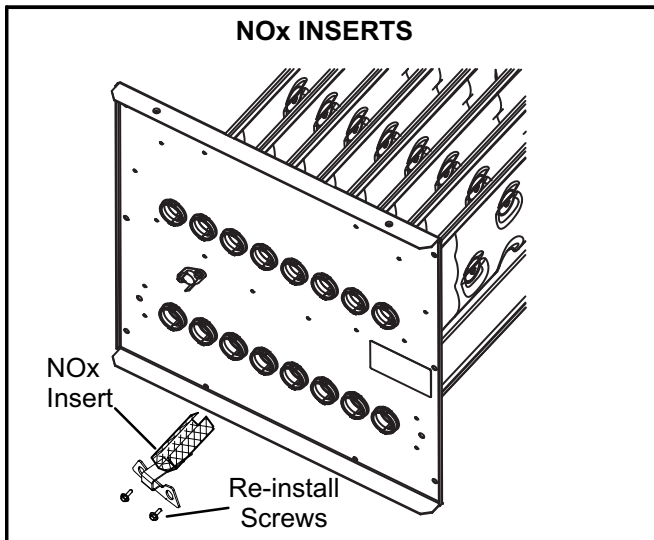

FIGURE 1

- 8 - Re-install the manifold/valve assembly.
- 9 - Thread provided brass fitting to gas valve inlet until hand tight. Using properly sized wrench, tighten fitting 2 to 3 full turns being careful to position the side port to allow clearance for the pressure switch and harness. See figure 4.

**NOTE** - Never use channel lock pliers or a pipe wrench on the brass fitting.

**NOTE** - Some installations may require the pressure switch and fitting assembly to be positioned differently than shown in figure 4.

- 10 - Thread the gas supply to the brass fitting until hand tight. Using properly sized wrench to support brass fitting, tighten supply line into fitting 2 to 3 full turns to achieve leak free joint.

**NOTE** - Do not over tighten. (Maximum 3 full turns past hand tight for 1/2" NPT per ASME B1.20.1-2013)

- 11 - Thread pressure switch (S145) to brass fitting 2 to 3 turns past hand tight, then wire as shown in figure 5.
- 12 - Restore the electrical power to the unit.
- 13 - Inspect all sides of assembly. Turn on gas supply. **Immediately check the entire fitting surface and assembly joints for gas leaks.**
- 14 - Affix nameplate conversion sticker next to unit nameplate.
- 15 - Complete the information required on the gas converter sticker: date, name, and address. Affix sticker to the exterior of the unit in a visible area.
- 16 - Follow the steps given in the start-up and adjustment section.

**⚠ IMPORTANT**  
 Carefully check all piping connection for gas leaks. **DO NOT** use matches, candles, open flames or other means of ignition to check for gas leaks. Use a soap solution or other preferred means.

**⚠ CAUTION**  
 Some soaps used for leak detection are corrosive to certain metals. Carefully rinse piping thoroughly after leak test has been completed. Do not use matches, candles, flame or other sources of ignition to check for gas leaks.

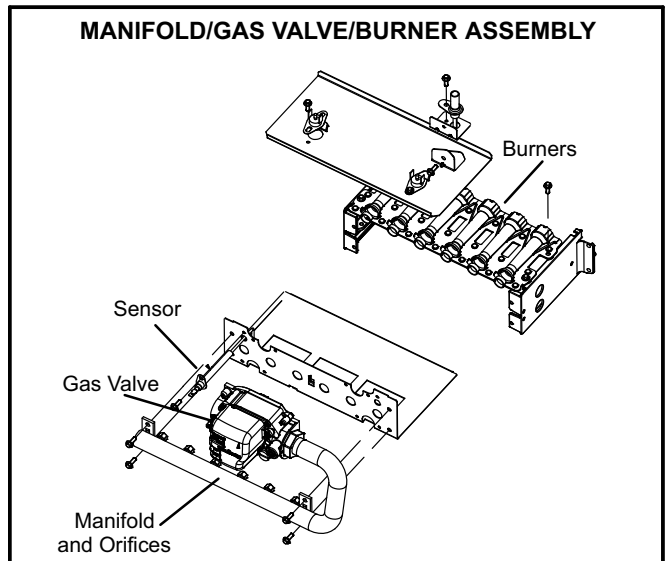

FIGURE 2

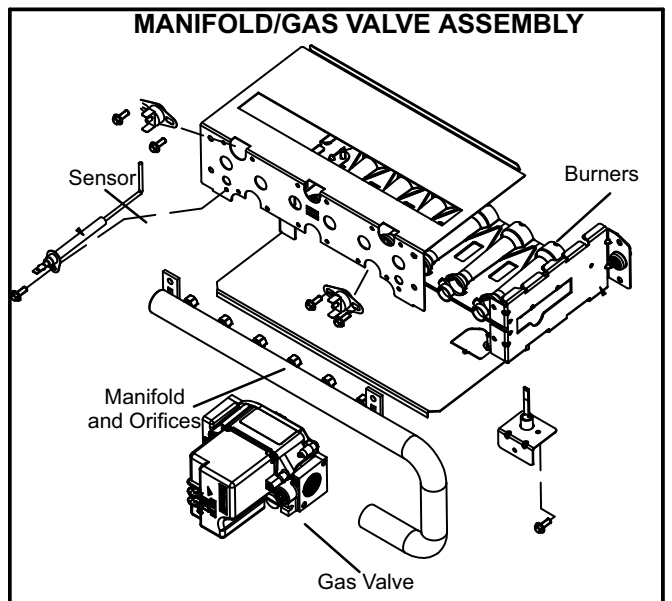
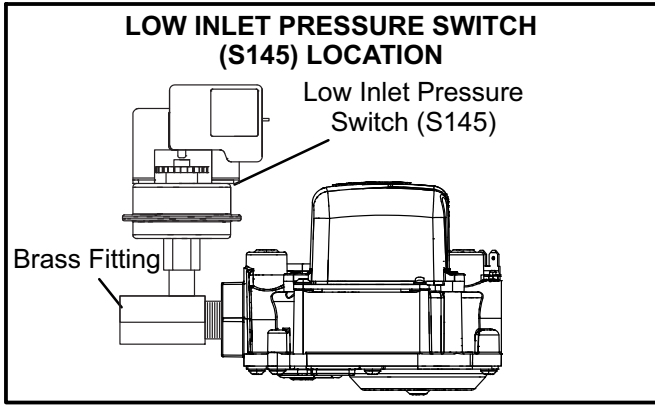
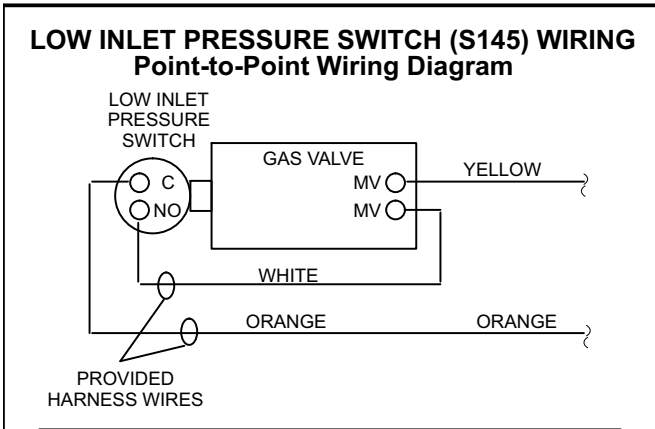

FIGURE 3



**FIGURE 4**



**Schematic Diagram**

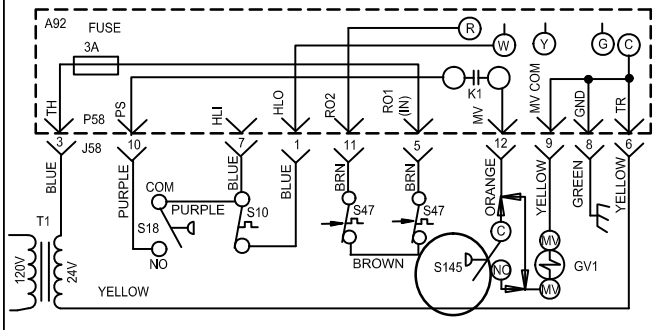

**FIGURE 5**

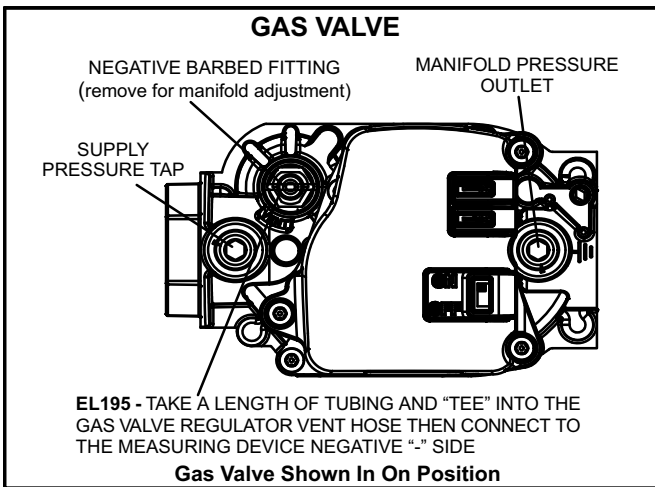

**FIGURE 6**

### CONVERSION OF GAS VALVE (Natural to LP/Propane)

1. Remove the barbed fitting (if equipped) and pressure regulator adjusting screw.
2. Remove the existing spring.
3. Insert the replacement spring.
4. Install the new plastic pressure regulator adjustment screw so that the top of the screw is flush (level) with the top of the regulator. Turn the pressure regulator adjusting screw clockwise six complete turns. This adjustment provides a preliminary pressure setting of about 10 inches w.c. for the LP /propane regulator.
5. Check the regulator setting either with a manometer or by clocking the gas meter.
6. Re-install the barbed fitting.

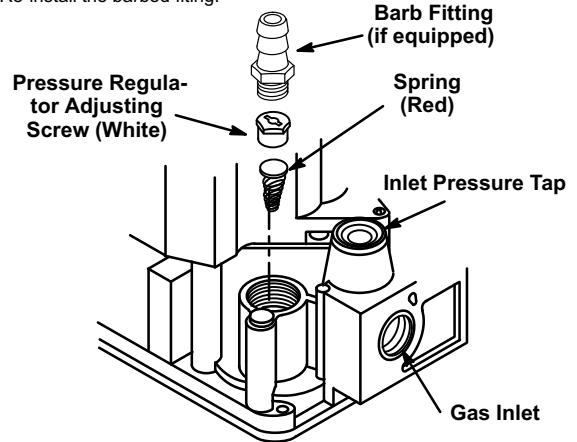

**FIGURE 7**

### Start-Up & Adjustment

**BEFORE LIGHTING** - Smell all around the appliance area for gas. Be sure to smell next to the floor because some gas is heavier than air and will settle on the floor. Use only your hand to turn the gas control switch. Never use tools. If the switch will not turn by hand, do not try to repair it. Force or attempted repair may result in a fire or explosion.

#### A - Placing the Unit into Operation

## ⚠ IMPORTANT

**Follow the lighting instructions provided on the unit. If lighting instructions are not available, refer to the following section.**

Units are equipped with a hot surface ignition system. The ignition system automatically lights the burners each time the thermostat calls for heat.

- 1 - **STOP!** Read the safety information at the beginning of this section.
- 2 - Set the thermostat to its lowest setting.
- 3 - Turn off all electrical power to the furnace.
- 4 - Do **not** try to light the burners by hand.
- 5 - Remove the unit access panel.
- 6 - Move gas valve switch to **OFF**. See figure 6.
- 7 - Wait five (5) minutes for any gas to clear out. If you then smell gas, **STOP!** Immediately call your gas supplier from a neighbor's phone. Follow the gas supplier's instructions. If you do not smell gas, go to the next step.
- 8 - Move gas valve switch to **ON**. See figure 6.
- 9 - Replace the unit access panel.

- 10 - Turn on all electrical power to the unit.
- 11 - Set the thermostat to desired setting.
- 12 - If the furnace will not operate, see the section "Turning Gas Off to the Unit" and call the gas supplier.

**Gas Pressure Measurement**

**A - Gas Flow (Approximate)**

**TABLE 1**

GAS METER CLOCKING CHART				
Unit	Seconds for One Revolution			
	Natural		LP	
	1 cu ft Dial	2 cu ft Dial	1 cu ft Dial	2 cu ft DIAL
-045	80	160	200	400
-070	55	110	136	272
-090	41	82	102	204
-110	33	66	82	164
-135	27	54	68	136
Natural-1000 btu/cu ft			LP-2500 btu/cu ft	

Furnace should operate at least 5 minutes before checking gas flow. Determine time in seconds for **two** revolutions of gas through the meter. (Two revolutions assures a more accurate time.) **Divide by two** and compare to time in table 1 below. If manifold pressure matches table 2 or 3 and rate is incorrect, check gas orifices for proper size and restriction. Remove temporary gas meter if installed.

**NOTE** - To obtain accurate reading, shut off all other gas appliances connected to meter.

**B - Supply Pressure Measurement**

When testing supply gas pressure, use the 1/8" N.P.T. supply tap located on the gas valve to facilitate test gauge connection. See figure 6. Check gas line pressure with unit firing at maximum rate. Low pressure may result in erratic operation or underfire. High pressure can result in permanent damage to gas valve or overfire.

On multiple unit installations, each unit should be checked separately, with and without units operating. Supply pressure must fall within range listed in tables 2 and or 3.

**C - Manifold Pressure Measurement EL195**

When testing manifold gas pressure, use the 1/8" N.P.T. plugged tap (manifold pressure outlet) located on the gas valve to facilitate test measuring device. See figure 6.

- 1 - Remove the threaded manifold pressure outlet plug from the gas valve and install the barbed fitting.
- 2 - Take a length of square tubing and connect one end to the barbed fitting and the other to the positive "+" side of the measuring device.
- 3 - Take another length of tubing and "tee" into the gas valve regulator vent hose. Connect to the measuring device negative "-" side.
- 4 - Start unit and allow 5 minutes for unit to reach steady state.

- 5 - After allowing unit to stabilize for 5 minutes, record manifold pressure and compare to value given in table 2.
- 6 - If necessary make adjustment. Turn off unit and remove the tubing from the negative (-) barbed fitting on the gas valve.
- 7 - Remove the negative barbed fitting as shown in figure 6 and using a screw driver make adjustment to increase or decrease manifold pressure.
- 8 - Repeat steps 1 through 7 until manifold pressure is correct.
- 9 - Shut unit off and remove manometer as soon as an accurate reading has been obtained. Take care to replace pressure tap plug.
- 10 -Start unit and perform leak check. Seal leaks if found.

**D - Manifold Pressure Measurement**

**ML180, EL180, 80AF1, ML193, ML195, 92AF1, 95AF1**

- 1 - Remove the threaded plug from the outlet side of the gas valve and install a field-provided barbed fitting. Connect to a manometer to measure manifold pressure. Propane gas should burn predominately blue with orange bursts at the point where the flame enters the heat exchanger.
- 2 - Start unit and allow 5 minutes for unit to reach steady state.
- 3 - While waiting for the unit to stabilize, observe the flame. Flame should be stable and should not lift from burner.
- 4 - After allowing unit to stabilize for 5 minutes, record manifold pressure and compare to value given in table 2 or 3.
- 5 - Shut unit off and remove manometer as soon as an accurate reading has been obtained. Take care to replace pressure tap plug.
- 6 - Start unit and perform leak check. Seal leaks if found.

**D - Proper Combustion**

Furnace should operate minimum 15 minutes with correct manifold pressure and gas flow rate before checking combustion. Take combustion sample beyond the flue outlet and compare to table 2 or 3.

**TABLE 2**  
**ML193,ML195, EL195, 92AF1, 95AF1**

Unit	CO <sub>2</sub> % For LP	Manifold Pressure	Line Pressure
All Models	8.4 - 9.6	10.0	11.0
The maximum carbon monoxide reading should not exceed 50 ppm.			

**TABLE 3**  
**ML180, EL180, 80AF1**

Unit	CO <sub>2</sub> % For LP	Manifold Pressure	Line Pressure
All Models	7.5 - 9.0	10.0	11.0
The maximum carbon monoxide reading should not exceed 50 ppm.			

**E - Turning Off Gas To the Unit**

- 1 - Set the thermostat to its lowest setting.
- 2 - Turn off all the electrical power to the unit.
- 3 - Move the switch on the gas valve to **OFF**. Do not force the switch.