



©2014 Lennox Industries Inc.
Dallas, Texas, USA

INSTALLATION INSTRUCTION

V33A 360° Cassette Units

VRF SYSTEMS — INDOOR UNITS
507443-01
11/2014

TP Technical
Publications



THIS MANUAL MUST BE LEFT WITH THE OWNER FOR FUTURE REFERENCE

These instructions are intended as a general guide and do not supersede local codes in any way. Consult authorities having jurisdiction before installation.

⚠ WARNING

Improper installation, adjustment, alteration, service or maintenance can cause property damage, personal injury or loss of life.

Installation and service must be performed by a licensed professional HVAC installer, service agency or the gas supplier.

Failure to follow safety warnings and these instructions exactly could result in property damage, dangerous operation, serious injury, or death.

Any additions, changes, or conversions required in order for the appliance to satisfactorily meet the application needs must be made by a licensed professional HVAC installer (or equivalent) using factory-specified parts.

Do not use this system if any part has been under water. A flood-damaged appliance is extremely dangerous. Immediately call a licensed professional HVAC service technician (or equivalent) to inspect the system and to replace all controls and electrical parts that have been wet, or to replace the system, if deemed necessary.

The State of California has determined that this product may contain or produce a chemical or chemicals, in very low doses, which may cause serious illness or death. It may also cause cancer, birth defects, or reproductive harm.

⚠ CAUTION

As with any mechanical equipment, personal injury can result from contact with sharp sheet metal edges. Be careful when you handle this equipment.

⚠ IMPORTANT

The Clean Air Act of 1990 bans the intentional venting of refrigerant (CFCs, HCFCs and HFCs) as of July 1, 1992. Approved methods of recovery, recycling or reclaiming must be followed. Fines and/or incarceration may be levied for noncompliance.

These units must be installed as a part of a matched system as specified in the Product Specifications (EHB) bulletin.

General

The V33A 360° cassette indoor units are matched with an outdoor heat recovery or heat pump unit to create a VRF (variable refrigerant flow) system that uses HFC-410A refrigerant.

Refer to the Product Specification bulletin (EHB) for the proper use of these indoor units with specific heat pumps, heat recovery units, mode switching devices, branch pipes, line sets and controls.

These instructions are intended as a general guide and do not supersede local or national codes in any way. Authorities having jurisdiction should be consulted before installation.

Shipping and Packing List

Check the components for shipping damage. If you find any damage, immediately contact the last carrier.

Package 1 of 2 contains the following:

- 1 - Assembled indoor cassette unit base
- 8 - Nuts
- 8 - Washers
- 4 - Cover panel screws
- 5 - Wire ties
- 1 - Condensate drain flexible pipe
- 1 - Condensate drain insulation sleeve
- 1 - Clasp
- 1 - Connector for electronic expansion valve and liquid line
- 1 - Cable
- 1 - Resistor
- 1 - Brass flare nut
- 1 - Template
- 1 - Installation manual

Package 2 of 2 contains the following:

- 1 - Assembled indoor unit cover panel

Safety Requirements

⚠ WARNING

ELECTRICAL SHOCK, FIRE, OR EXPLOSION HAZARD.

Do not touch the unit or the controller if your hands are wet.

DO NOT spray water on the indoor unit for any reason.

Do not replace a fuse with a fuse of a different rating. Do not use a jumper wire to replace a fuse.

Do not insert your hands, tools or any other item into the air intake or air outlet at either the indoor or outdoor unit.

Do not allow children to operate the system.

Model Number Identification

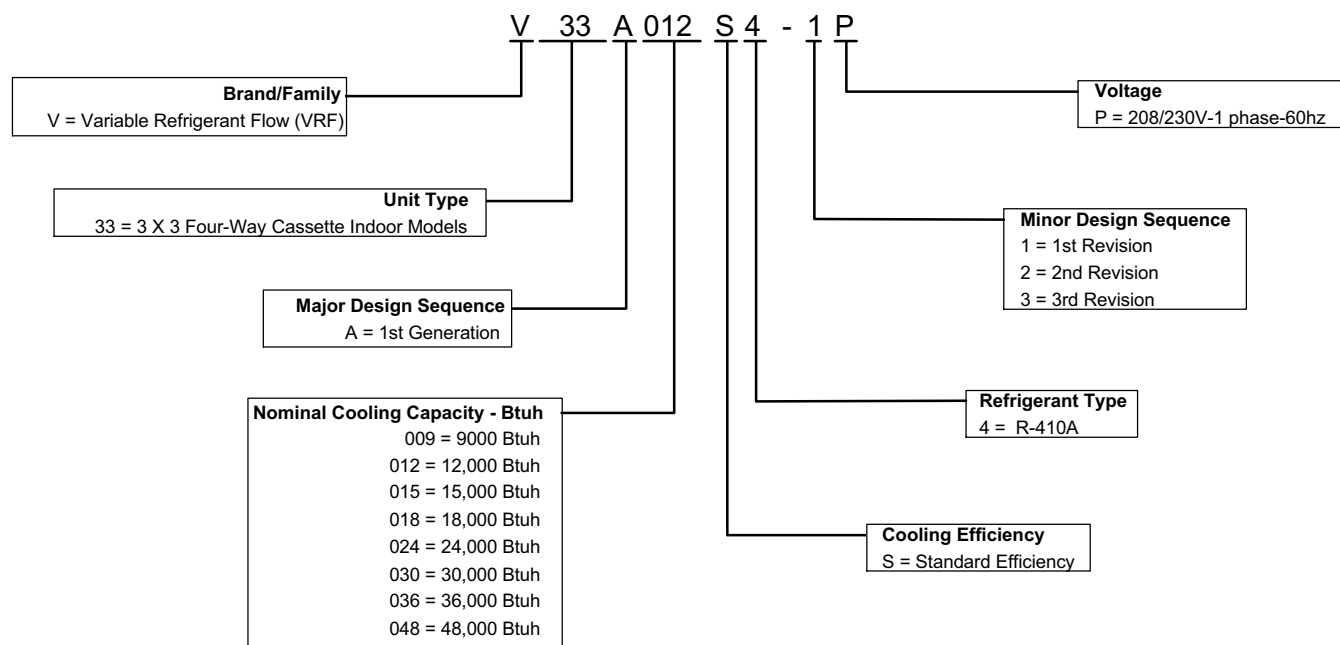

Unit Dimensions - inches (mm) and Weights

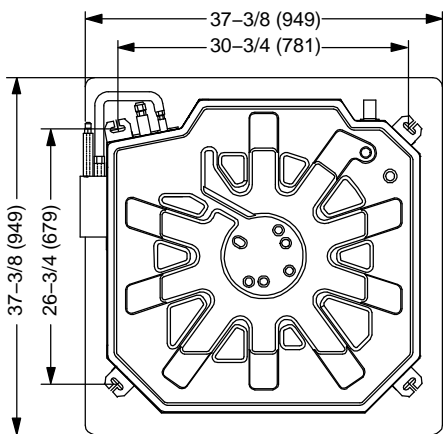

TOP VIEW

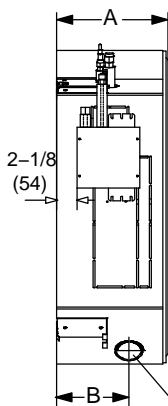

**3 (76)
FRESH AIR
INTAKE OPENING**

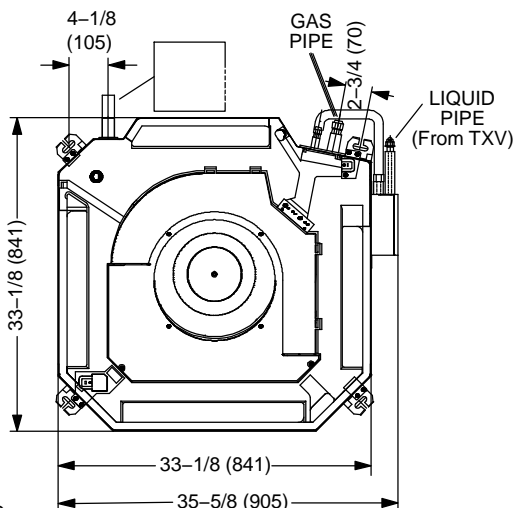

BOTTOM VIEW

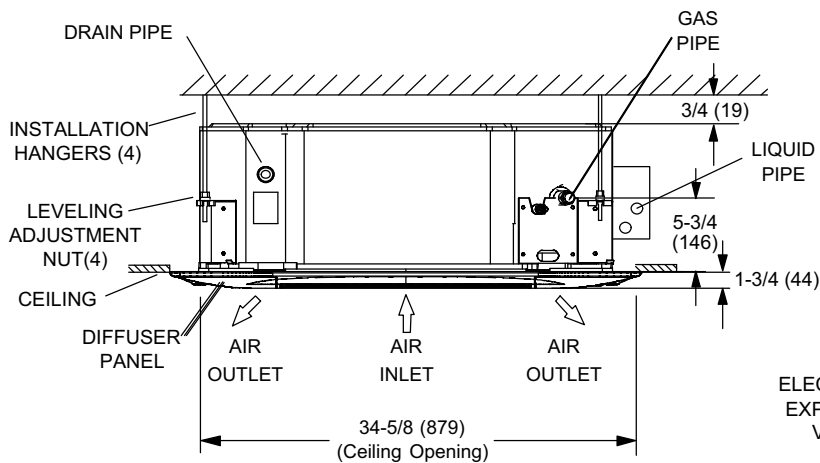

SIDE VIEW

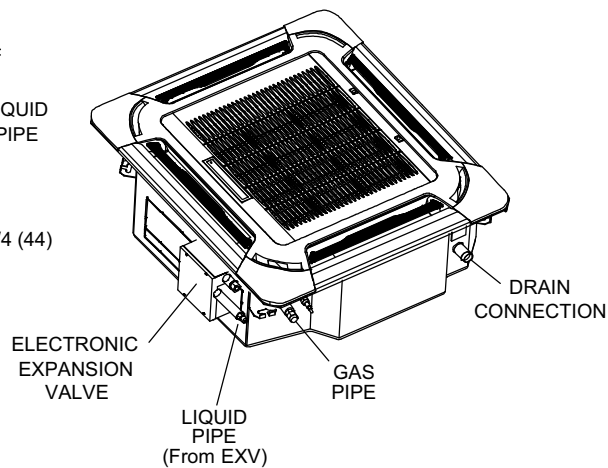

BOTTOM (PANEL) VIEW

Size	A		B	
	in.	mm	in.	mm
009, 012, 015, 018, 024	9	229	5	127
030, 036, 048	11-7/8	302	7-3/4	197

Clearances

Refer to figure 1 for minimum clearance requirements.

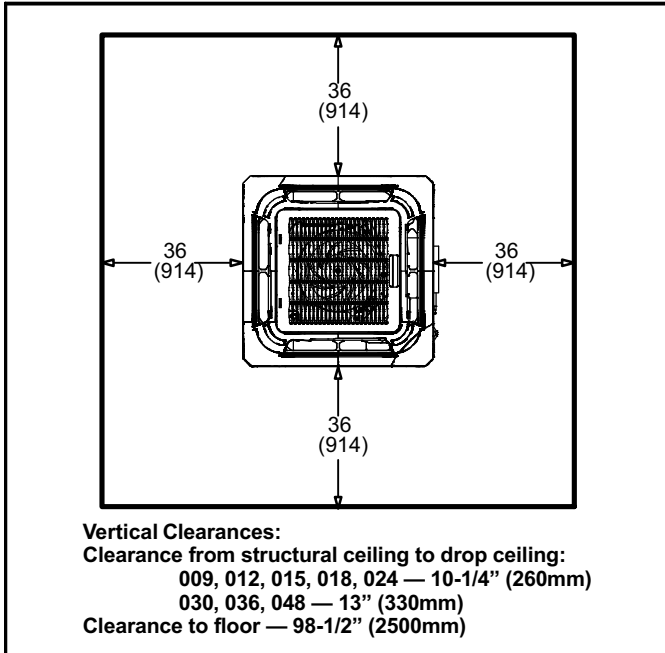

Figure 1. Minimum Installation Clearances

Indoor Unit Placement

In addition to clearances, the following items should be considered:

⚠ WARNING

Use the provided and specified components when installing equipment. Failure to do so may result in unit falling, water leaking or electrical shocks, causing personal injury or equipment or property damage.

Check stability of ceiling and unit support. If support is not capable of carrying weight of the unit, unit may fall causing personal injury or equipment damage.

Safely dispose of packing materials, which include nails, wood and other sharp objects, as well as plastic wrapping. Children playing with plastic wrap or bags risk the danger of suffocation.

⚠ CAUTION

Do not place items which may be damaged by water under or around the indoor unit.

The unit should be installed at least 8 feet above the floor (if possible) to ensure maximum performance and comfort.

AVOID

Do not install the unit in the following locations:

- Areas exposed to salt or other corrosive materials or caustic gases

- Areas exposed to extreme voltage variations (such as factories)
- Tightly enclosed areas that may impede service of the unit.
- Areas exposed to strong electromagnetic forces
- Areas exposed to acids or alkaline detergents (laundry rooms)

DO:

- Locate the unit so that it is central to the area being conditioned.
- Locate the unit so that it is not exposed to direct sunlight.
- Locate the indoor unit so that the room can be uniformly cooled. Install unit at least 8 feet above floor, if possible, for best performance.
- Select a ceiling location that can support the weight of the unit.
- Select a location where condensate line will have the shortest run to a suitable drain per local codes.
- Allow sufficient space around unit for proper operation and maintenance (filter must be able to be removed from the bottom of the unit).
- Install the indoor unit a minimum of 3 feet away from any antenna, power cord (line), radio, telephone, security system, or intercom. Electrical interference and radio frequencies from any of these sources may affect operation.

Cassette Base Installation

It is important to locate the cassette unit in the center of the area that is being conditioned. This will provide the best air distribution.

- 1 - If the unit is to be installed in an application that includes a drop-down tile ceiling, remove the ceiling tiles necessary to accommodate installation of the four-way cassette. Before removing the drop ceiling support grid, use a plumb line or laser device to identify the center point of the structural ceiling. **Make sure that the ceiling is supported before removing any of the support grid. It may be necessary to add extra support to maintain the structural integrity of the drop ceiling.**
- 2 - If the unit is to be installed in an application that includes a sheet rock (plasterboard) ceiling, the installation site must be carefully measured and the sheet rock must be cut to accommodate the cassette unit. First, identify the center point of the installed cassette. Use a plumb line to transfer the center mark to the floor for future use. Use the provided template to mark the area of the required opening. Carefully cut the required opening. **Make sure that the removal of the required ceiling support does not affect the structural integrity of the ceiling. It may be necessary to add extra support.**
- 3 - Use the unit as a template or use the provided paper template to mark the location of the hanging brackets on the floor. Use a plumb line or a laser to transfer the bracket positions to the main structural ceiling.
- 4 - **Make sure that the structural ceiling is able to support the weight of the cassette unit. It may be**

necessary to add extra support. If the structural ceiling is constructed of concrete, install anchors to accept four $\frac{3}{8}$ " threaded rods to suspend the cassette base. If the structural ceiling includes wooden joists, use angle iron or a Unistrut channel fixed securely in place to accept the $\frac{3}{8}$ " threaded rods. See figure 2.

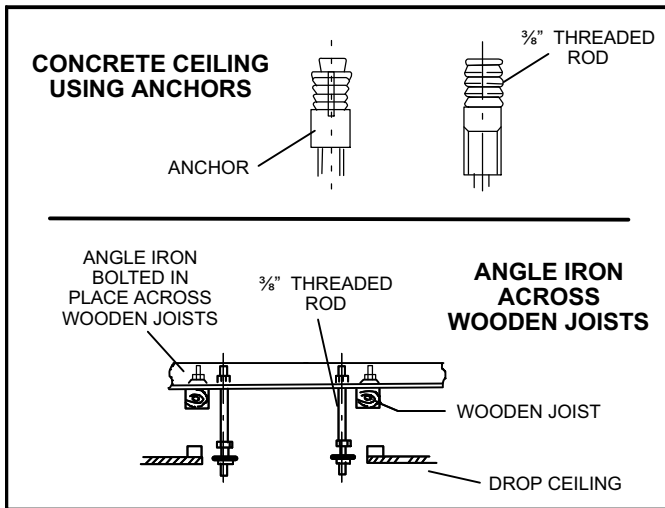

Figure 2. Suspending Methods

- 5 - Slide one nut and one washer onto each threaded rod. Use electrical tape to keep the washer from falling off. Position the nuts slightly above the final resting place of the four suspension brackets. See figure 2.
- 6 - Use either a mechanical lifting device or a minimum of two people to raise the unit and insert the threaded rods into the suspension brackets on the cassette base. Slide a washer and then a nut onto each rod below each suspension bracket. Use the leveling nut (beneath suspension bracket) to adjust the cassette base to the correct height. Remove the electrical tape holding the upper washers and nuts in place and tighten each of the four nuts above the brackets down onto the brackets. This will ensure that the unit remains level.

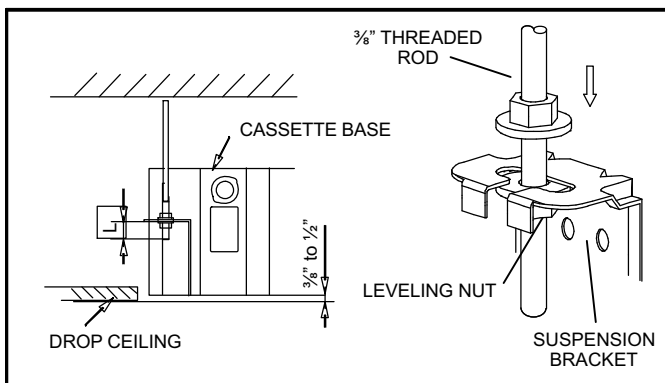

Figure 3. Suspension Hardware

- 7 - If the unit is being installed in an application that includes a sheet rock (plasterboard) ceiling, it is recommended to install an access panel in a suitable location to allow final connection of the refrigerant

piping, condensate line and electrical connections. This will also allow access for future maintenance. If this is not possible, make final connections before installing cassette cover panel.

Refrigerant Piping Connections

⚠ WARNING

Refrigerant leaks are unlikely; however, if a refrigerant leak occurs, open a door or windows to dilute the refrigerant in the room. Turn off the unit and all other appliances that may cause a spark. Call a licensed professional HVAC technician (or equivalent) to repair the leak.

Use only R410A refrigerant to charge this system. Use of other refrigerant or gas will damage the equipment.

Do not allow air or other contaminants to enter system during installation of refrigerant piping. Contaminants will result in lower system capacity and abnormally high operating pressures and may result in system failure or explosion.

Insulate all refrigerant piping.

Refrigerant pipes may be very hot during unit operation. Do not allow contact between wiring and bare copper pipes.

After refrigerant piping connections have been completed, check the system for leaks per commissioning instructions.

Field piping consists of two copper lines connected to the indoor unit. Table 1 lists the connection sizes at the indoor unit. The connections are made using the provided brass flare nuts at the end of the refrigerant piping connections.

Both lines must be individually insulated.

- 1 - The seal on the unit refrigerant piping connections should remain in place until the last possible moment. This will prevent dust or water from getting into the refrigerant piping before it is connected.
- 2 - Slowly loosen one of the flare nuts to release the factory nitrogen charge.
- 3 - Remove the flare nuts from the connections on the cassette base and discard the seal from each of the piping connections.
- 4 - Slide the flare nuts onto the ends of the field-provided refrigerant piping **before** using a suitable flaring tool to flare the end of the copper pipe.
- 5 - Apply recommended HFC-410A refrigerant lubricant to the outside of the flared refrigerant lines (figure 4-A and figure 6).

IMPORTANT !

Mineral oils are not compatible with HFC-410A.

- 6 - Align the threaded connections with the flared refrigerant lines. Tighten the flare nuts lightly at first to obtain a smooth match (figure 4-B and figure 6).

Table 1. Refrigerant Piping Connections

System Size (Btuh)	Liquid Line	Vapor Line
7000 12000 15000	1/4 in.	1/2 in.
18000 24000 30000 36000 48000	3/8 in.	5/8 in.

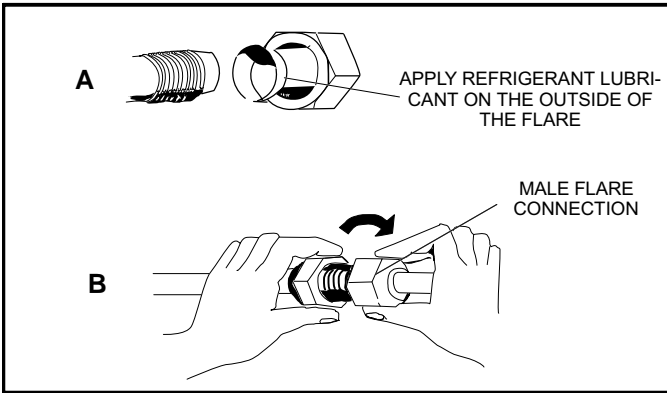

Figure 4. Making Connections at Indoor Unit (Male to Female Connection)

7 - Once snug, continue another half-turn on each nut which should create a leak-free joint. A torque wrench may be used to tighten flare nuts using table 2 recommendations. (see figure 5). **Do not over-tighten a flared joint.**

IMPORTANT !

Always use two wrenches when tightening flare nuts to avoid twisting refrigerant piping. **DO NOT over-tighten flare nuts.**

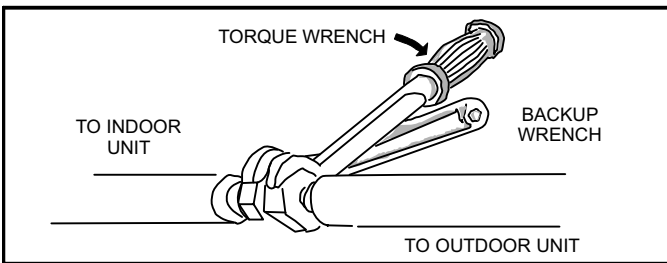

Figure 5. Tighten Flare Nut

Table 2. Flare Nut Torque Recommendations

Outside Diameter	Recommended Torque	No torque wrench available Finger tighten and use an appropriately sized wrench to turn an additional:
	U.S.	
Inches		
1/4"	15 ft.-lb.	1/4 turn
3/8"	26 ft.-lb.	1/2 turn
1/2"	41 ft.-lb.	7/8 turn
5/8"	48 ft.-lb.	1 full turn

8 - Locate the pre-formed copper connector pipe provided in the bag assembly. This pipe is used to connect the cassette piping to the electronic

expansion valve. Remove the plastic seal from each end of the pipe.

- Apply a small amount of recommended HFC-410A refrigerant lubricant to the outside of the flared ends of the connector.
- Immediately align the connector pipe with the cassette base liquid line and the electronic expansion valve connection labeled "OUTLET." See figure 6. Hand-tighten the flare nuts at first. Then, use two wrenches to continue to tighten the nuts without twisting the pipes. See figure 5. Torque requirements are given in table 2. **Again, do not over-tighten the flared joints.**

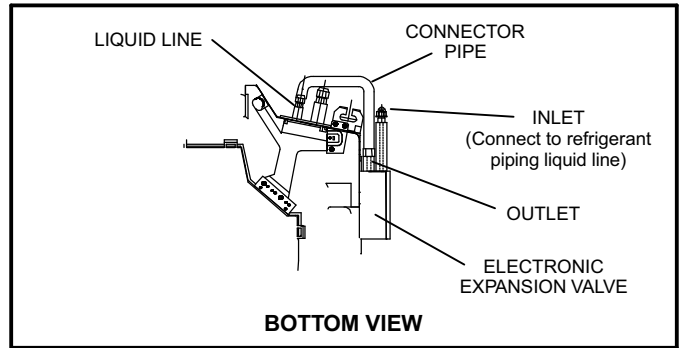

Figure 6. Liquid Line / Expansion Valve Connector

11 - After refrigerant piping has been installed and checked for leaks, apply insulation over the connector pipe and all flared connections.

IMPORTANT !

Flared connections should always be accessible and must be insulated to prevent condensation. See figure 7.

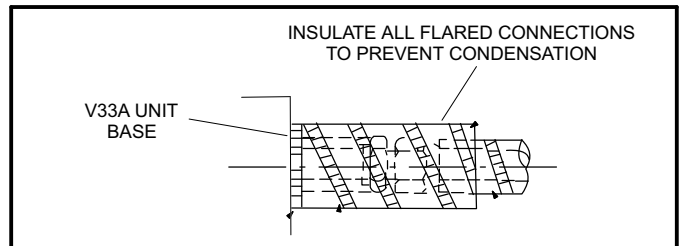

Figure 7. Insulate Flared Connections

Condensate Drain Connections

CAUTION

Make sure that drain piping is properly routed and insulated in order to prevent both leaks and condensation.

- Use the provided hose clamp to secure the provided flexible condensate drain connector to the drain line stub on the side of the cassette base. Wrap the flexible connector with the provided insulation. **NOTE - Take care not to over-tighten the hose clamp as this may damage the drain line stub.**
- Make a water-tight connection between the field-provided condensate drain line and the flexible condensate connector. Use 1-1/2" OD / 1-1/4" ID PVC pipe for the drain line.

- 3 - See figure 8 for applications including a single unit and a single drain. In this case, ensure that the drain line is properly sloped (no less than 1/4 inch per foot) and condensate lines are routed to ensure moisture is drained away from the indoor unit.

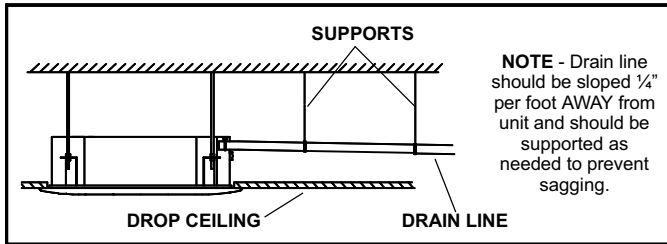

Figure 8. Sloped Condensate Drain — Single Unit

IMPORTANT !

Drain should have a slope of at least 1/4 inch per foot and should be approved corrosion-resistant pipe.

- 4 - See figure 10 for applications including multiple units using the internal pump to provide lift into a single, correctly sized main drain. In this case, ensure that the main drain line is properly sloped (no less than 1/4 inch per foot) and that each individual drain is connected to the main drain exactly as shown.
- 5 - Drain should be as short as possible and should not have any droops or kinks that would restrict condensate flow and shall be approved resistant pipe.
- 6 - **After system installation is complete, the condensate drain line must be checked for leaks**

and the condensate pumps must be checked to ensure proper operation. This check is part of the commissioning sequence. Pour water into the evaporator drain pan to ensure proper condensate drainage. See figure 9. If a leak is found, shut down power to the unit at once and do not restore power to the unit until the problem has been resolved.

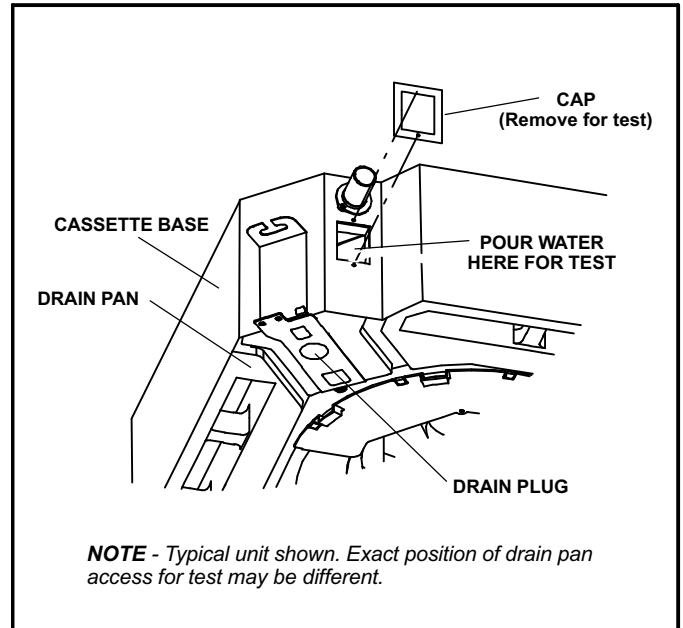

Figure 9. Condensate Drain Test

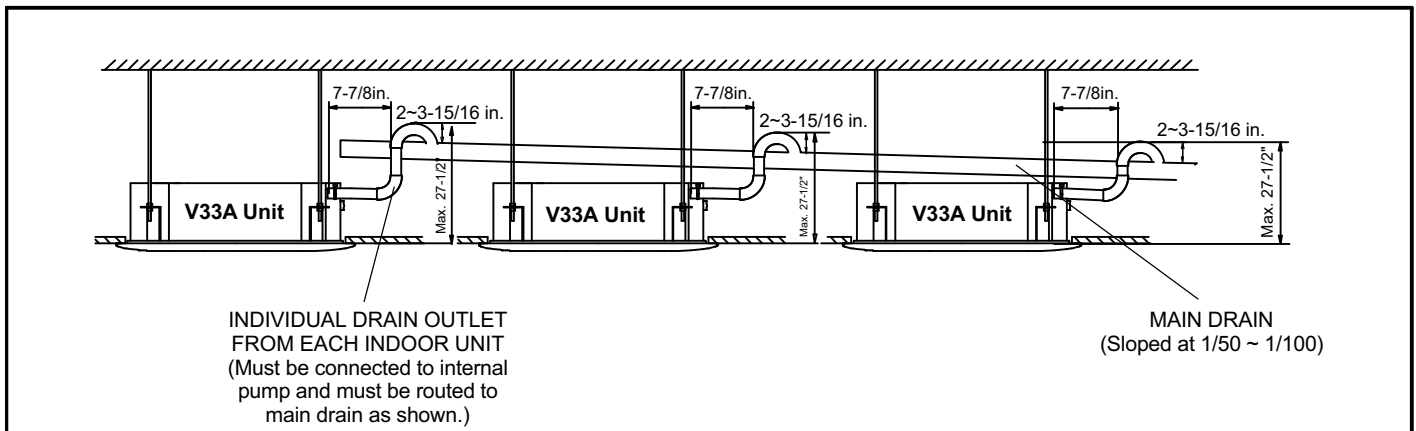

Figure 10. Using a Main Drain to Serve Multiple Indoor Units

Wiring Connections

⚠ WARNING

Isolate the power supply before accessing unit electrical terminals.

Install unit so that unit disconnect is accessible.

Follow all local and national codes, as well as this installation instruction, during installation. Do NOT overload electrical circuit, as this may lead to failure and possible fire.

Use specified wiring and cable to make electrical connections. Clamp cables securely and make sure that connections are tight to avoid strain on wiring. Insecure wiring connections may result in equipment failure and risk of fire.

Wiring must be installed so that all cover plates can be securely closed.

Do not attempt to repair a damaged power cord.

Do not modify the power cord in any way. Do not attempt to extend the length of the power cord or use an extension cord with this appliance. Do not share the single power outlet with any other appliances.

In the U.S.A., wiring must conform with current local codes and the current National Electric Code (NEC). In Canada, wiring must conform with current local codes and the current Canadian Electrical Code (CEC).

Refer to unit nameplate for minimum circuit ampacity and maximum overcurrent protection size.

NOTE - Three-conductor (three-wire) shielded cable must be used for the communication wiring. This is necessary to ensure proper system communication and operation.

⚠ CAUTION

This unit must be properly grounded and protected by a circuit breaker. The ground wire for the unit must not be connected to a gas or water pipe, a lightning conductor or a telephone ground wire.

Do not connect power wires to the outdoor unit until all other wiring and piping connections have been completed.

Install all wiring at least 3 feet away from televisions, radios or other electronic devices in order to avoid the possibility of interference with the unit operation.

Do not install the unit near a lighting appliance that includes a ballast. The ballast may affect remote control operation.

- 1 - Remove the screws that secure the control box cover. Remove the cover and place it to the side where it will not be damaged.
- 2 - Locate the terminal strip in the control box. Connect the power wiring (sized per NEC/CEC and local codes) and communications cable (**three-conductor, shielded cable**) per figure 12. Refer to unit nameplate for rated voltage.
- 3 - If the indoor unit is the final unit in a group that is wired in series, install the provided resistor across terminals P and Q. Refer to figure 11.
- 4 - The wiring harnesses to the swing motors and the cover panel display are routed and connected as part of the cassette cover panel installation, which follows.

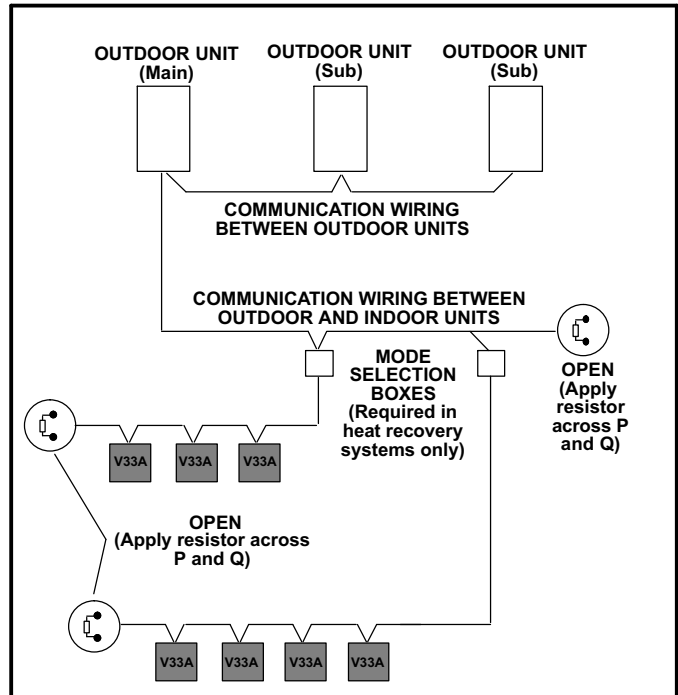

Figure 11. Typical Series Wiring of Indoor Units (with resistors)

IMPORTANT !

DO NOT adjust DIP switch settings. Settings may only be adjusted by a trained technician as part of the commissioning procedures.

Network Address and Commissioning

After the system has been installed, each indoor unit must be assigned an address as part of the commissioning procedure.

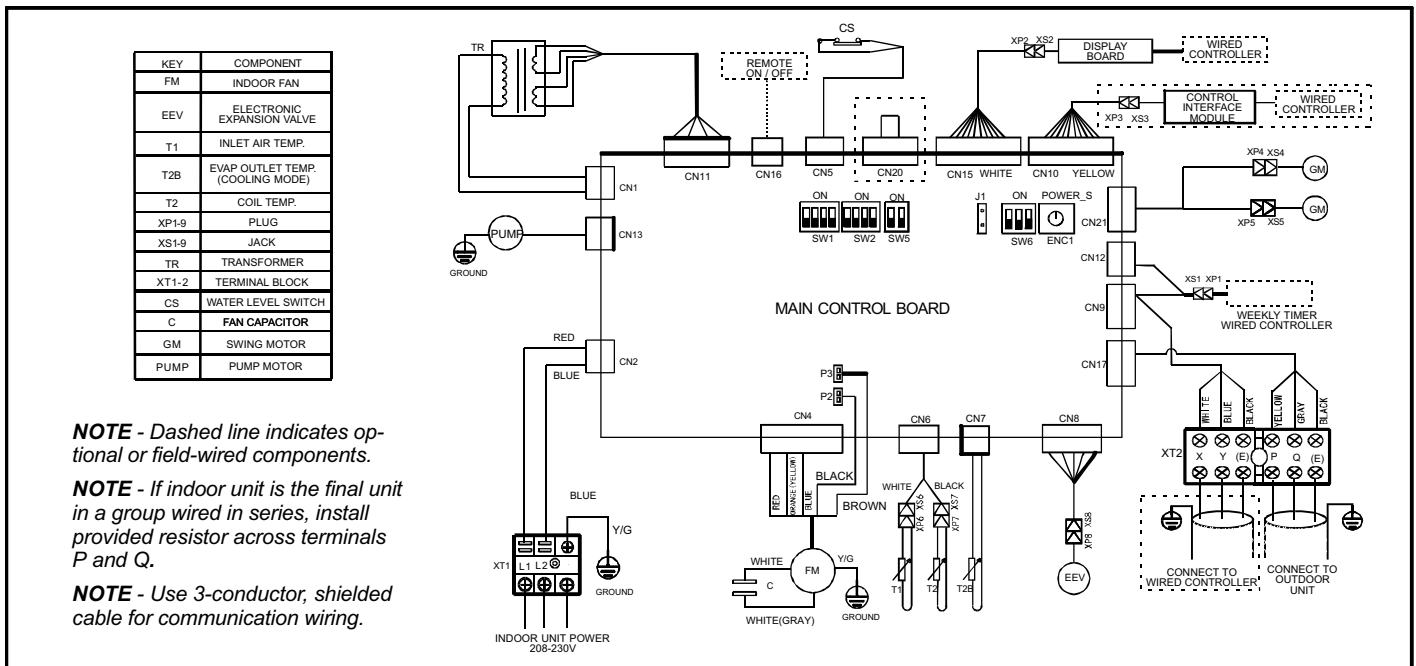

Figure 12. Typical V33A Wiring Diagram

Cassette Cover Panel Installation

- 1 - Carefully remove the cassette cover panel from its protective packaging and place the panel diffuser-side-out on a clean, level surface.

CAUTION

Do not place the cover panel with the diffusers face down on the floor or other surface. Louvers will be damaged if pressure is applied to them.

- 2 - Press the two grille latch release buttons at the same time to release the grille. See figure 13. Tilt the return air grille outward at a 45° angle and lift the grille away from the panel. Carefully place the return air grille off to the side.

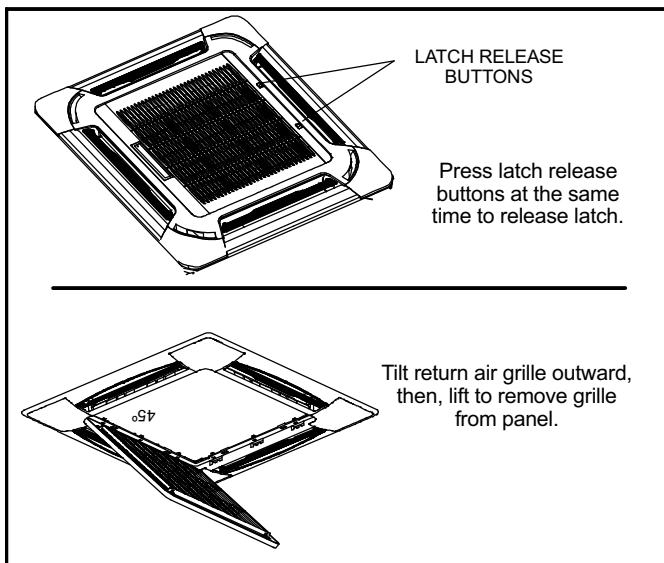

Figure 13. Remove Return Air Grille

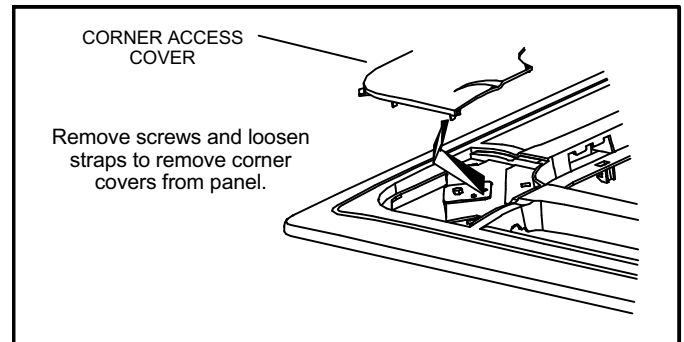

Figure 14. Remove Corner Covers

- 3 - Remove access covers from each corner of the panel. See figure 14.
- 4 - Position the cover panel so that the arrow on the panel is aligned with the arrow sticker on the cassette base. **NOTE** - If the panel and the base are not properly aligned, the airflow will be blocked.
- 5 - Locate the cover panel hangers on the two corners with the louver swing motors. Place these two hangers on the corresponding hooks on the corners of the cassette base. See detail A in figure 15. Then, place the other hangers from the other two corners over their corresponding hooks on the cassette base as shown in detail B in figure 15.
- 6 - Connect the six-pin harness plugs from each of the two swing motors to the matching six-pin plugs from the control box in the cassette base.
- 7 - Connect the black harness from the display on the cover panel to the corresponding black plug from the control box in the cassette base.
- 8 - Connect the black two-pin plug from the temperature sensor to the corresponding black plug from the control box in the cassette base.
- 9 - Tighten the provided screws in the bracket in the cover panel immediately below each panel hanger. See

detail C in figure 15. Adjust the cover panel by turning slightly clockwise, if necessary, to make sure that the panel is properly aligned with the cassette base.

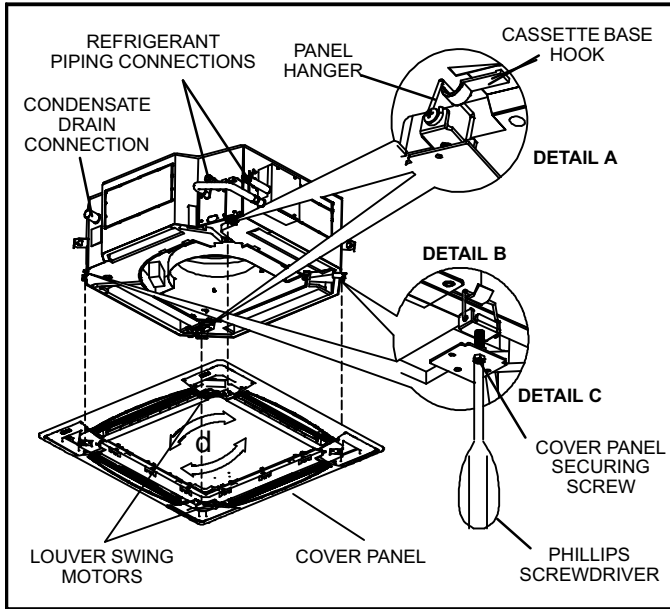

Figure 15. Install Cover Panel

- 10 - Continue to tighten the cover panel securing screws until the insulation between the cover panel and the cassette base has been compressed to approximately $\frac{1}{4}$ ". The cover panel must form a seal with the ceiling and the cassette base around the entire perimeter of the unit. See figure 16.
- 11 - If it is necessary to adjust the cassette height after the cover panel has been installed, access the leveling nut through the removable access cover on each corner. See figure 17.
- 12 - The return air grille must be reinstalled on the cover panel. Align the four tabs on the grille with the four slots in the cover panel. Tilt the panel back into place.

Press the opposite side of the cover gently until the latches engage.

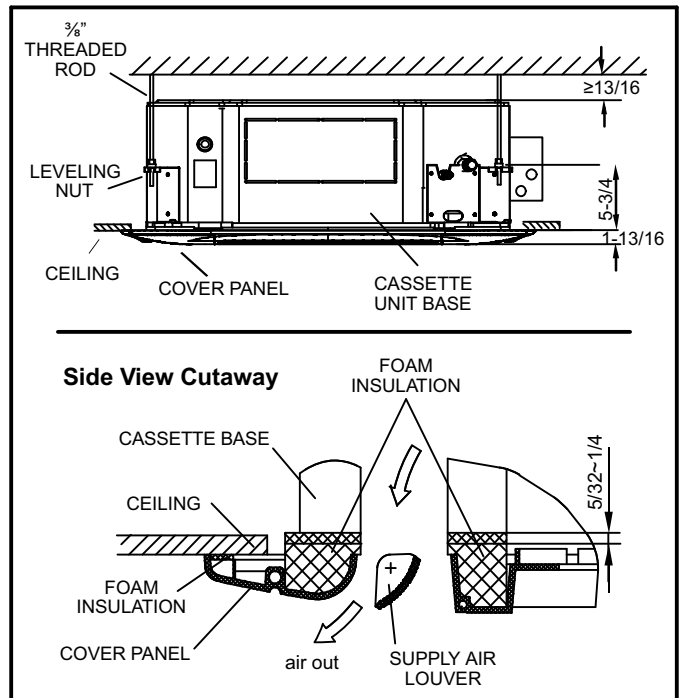

Figure 16. Cover Panel in Place

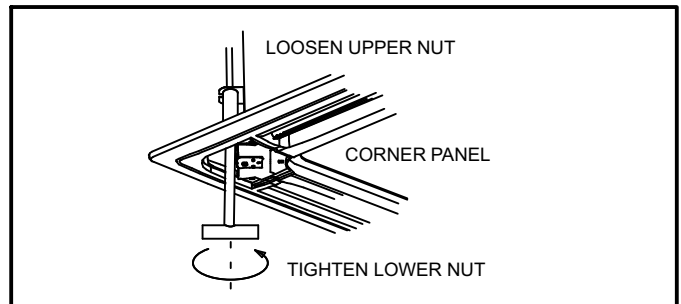

Figure 17. Adjust Unit Height Through Corner Panel