



©2014 Lennox Industries Inc.  
Dallas, Texas, USA



**THIS MANUAL MUST BE LEFT WITH THE OWNER FOR FUTURE REFERENCE**

### **⚠ WARNING**

**Improper installation, adjustment, alteration, service or maintenance can cause property damage, personal injury or loss of life.**

**Installation and service must be performed by a licensed professional HVAC installer, service agency or the gas supplier.**

**Failure to follow safety warnings and these instructions exactly could result in property damage, dangerous operation, serious injury, or death.**

**Any additions, changes, or conversions required in order for the appliance to satisfactorily meet the application needs must be made by a licensed professional HVAC installer (or equivalent) using factory-specified parts.**

**Do not use this system if any part has been under water. A flood-damaged appliance is extremely dangerous. Immediately call a licensed professional HVAC service technician (or equivalent) to inspect the system and to replace all controls and electrical parts that have been wet, or to replace the system, if deemed necessary.**

**The State of California has determined that this product may contain or produce a chemical or chemicals, in very low doses, which may cause serious illness or death. It may also cause cancer, birth defects, or reproductive harm.**

# INSTALLATION INSTRUCTIONS

## VCFA Convertible Ceiling / Floor-Mount Indoor Units

VRF SYSTEMS -- Ceiling/Floor Indoor Units  
507444-01  
12/2014

### **General**

The VCFA ceiling/floor-mount non-ducted indoor units are matched with an outdoor heat recovery or heat pump unit to create a VRF (variable refrigerant flow) system that uses HFC-410A refrigerant. The units can be suspended from the ceiling in a horizontal position or installed on the wall near the floor in a vertical position.

Refer to the Product Specification bulletin (EHB) for the proper use of these indoor units with specific heat pumps, heat recovery units, mode switching devices, branch pipes, line sets and controls.

These instructions are intended as a general guide and do not supersede local codes in any way. Consult authorities having jurisdiction before installation.

### **Shipping and Packing List**

Check the components for shipping damage. If you find any damage, immediately contact the last carrier.

Package 1 of 1 contains the following:

- 1 - Assembled indoor unit
- 4 - Nuts
- 4 - Washers
- 2 - Suspension brackets (ceiling mount) NOTE -not provided with VCFA054
- 2 - Mounting brackets (wall/floor mount)
- 1 - Resistor
- 1 - Brass flare nut
- 1 - Installation manual
- 1 - Condensate drain flexible pipe
- 1 - Condensate drain insulation sleeve (VCFA054 only)

### **⚠ CAUTION**

**As with any mechanical equipment, personal injury can result from contact with sharp sheet metal edges. Be careful when you handle this equipment.**

# Safety Requirements

## ⚠ WARNING

### ELECTRICAL SHOCK, FIRE, OR EXPLOSION HAZARD.

Do not touch the unit or the controller if your hands are wet.

DO NOT spray water on the indoor unit for any reason.

Do not replace a fuse with a fuse of a different rating. Do not use a jumper wire to replace a fuse. Do not insert your hands, tools or any other item into the air intake or air outlet at either the indoor or outdoor unit.

Do not allow children to operate the system.

# Model Number Identification

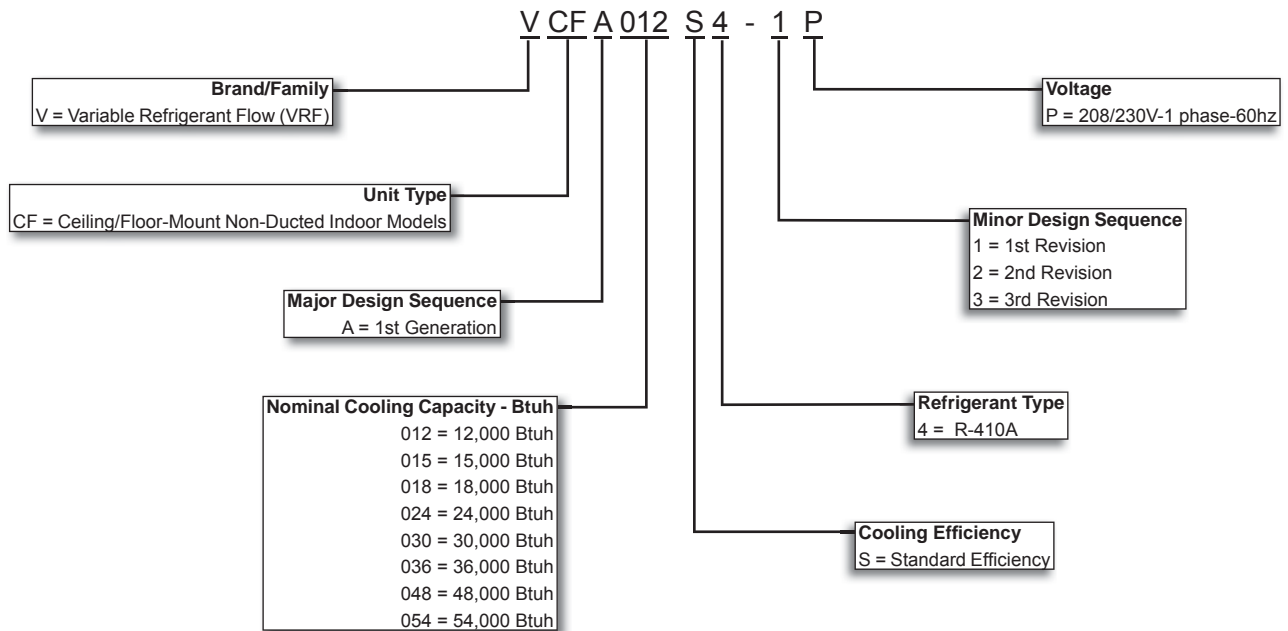

**Dimensions**

**VCFA012S4, VCFA015S4, VCFA018S4, VCFA024S4**

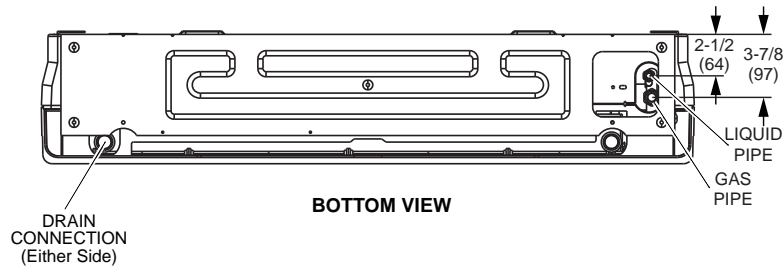
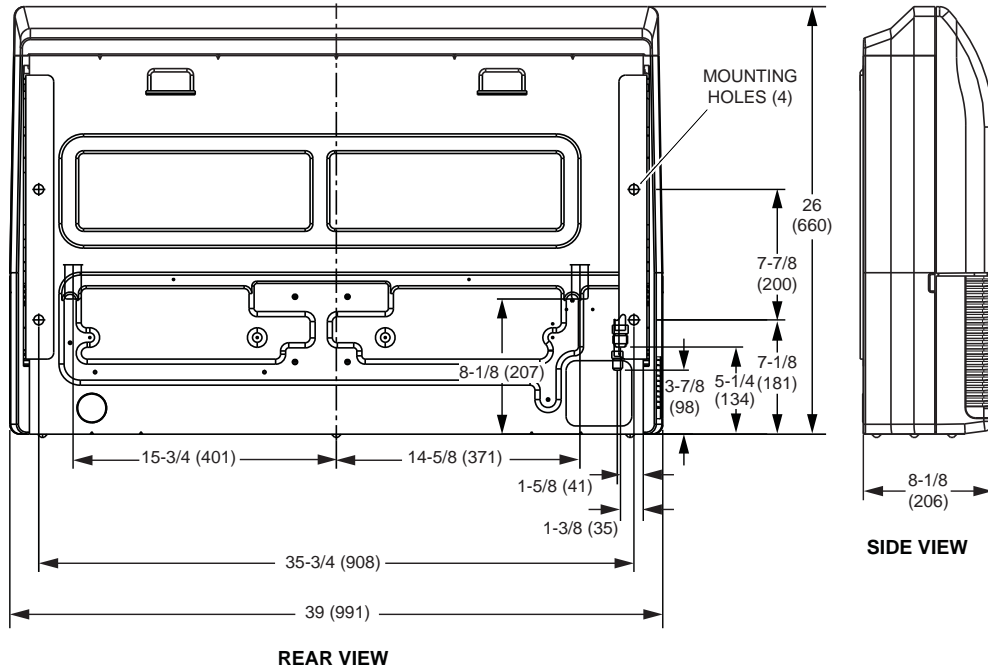

**VCFA030S4**

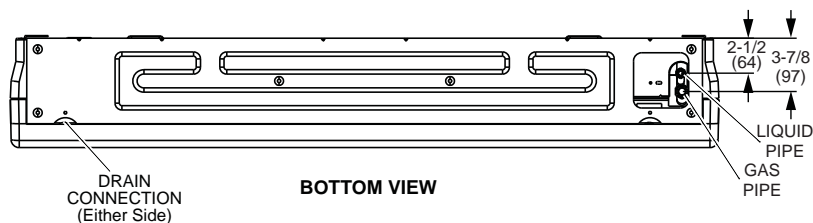
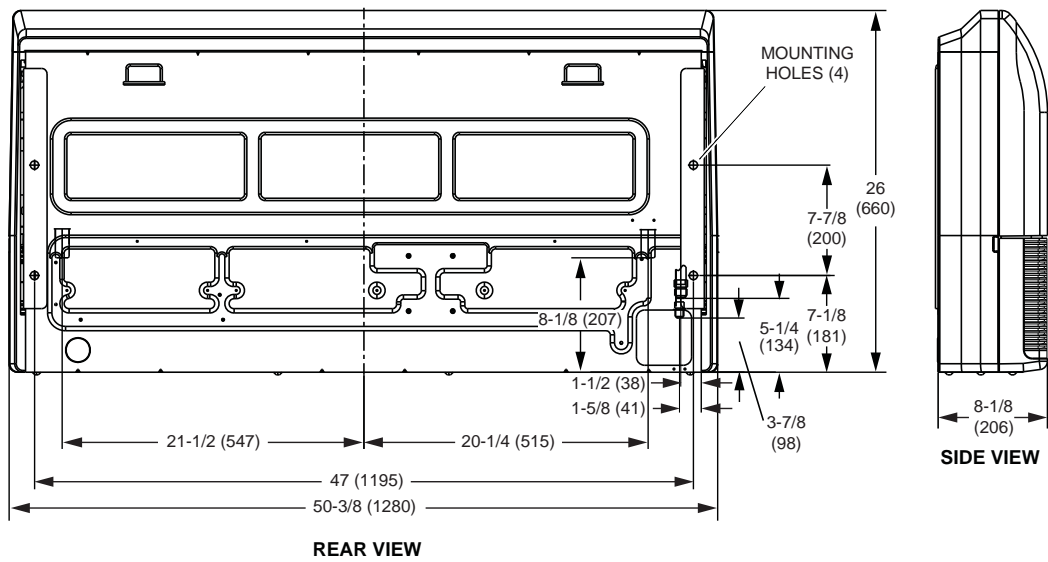

VCFA036S4, VCFA048S4

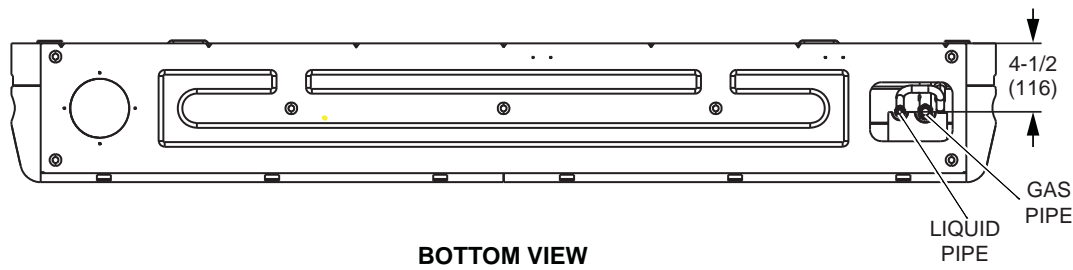
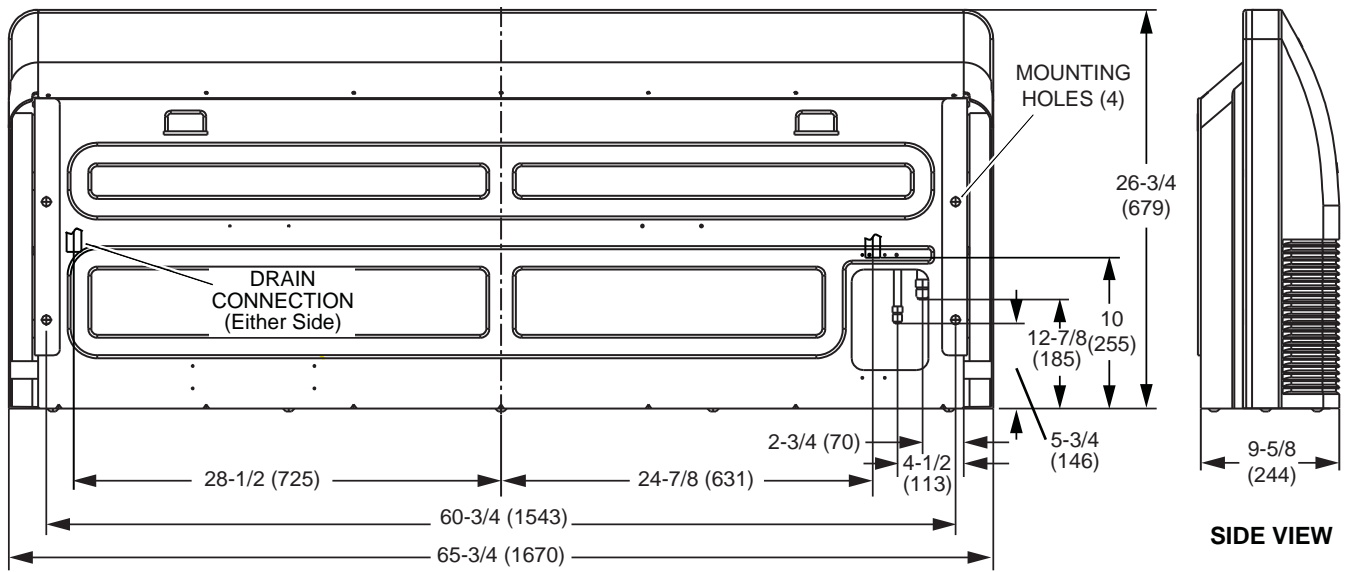

VCFA054S4

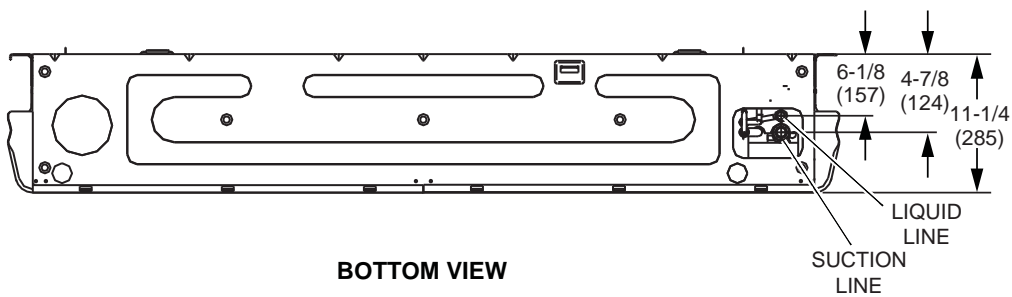
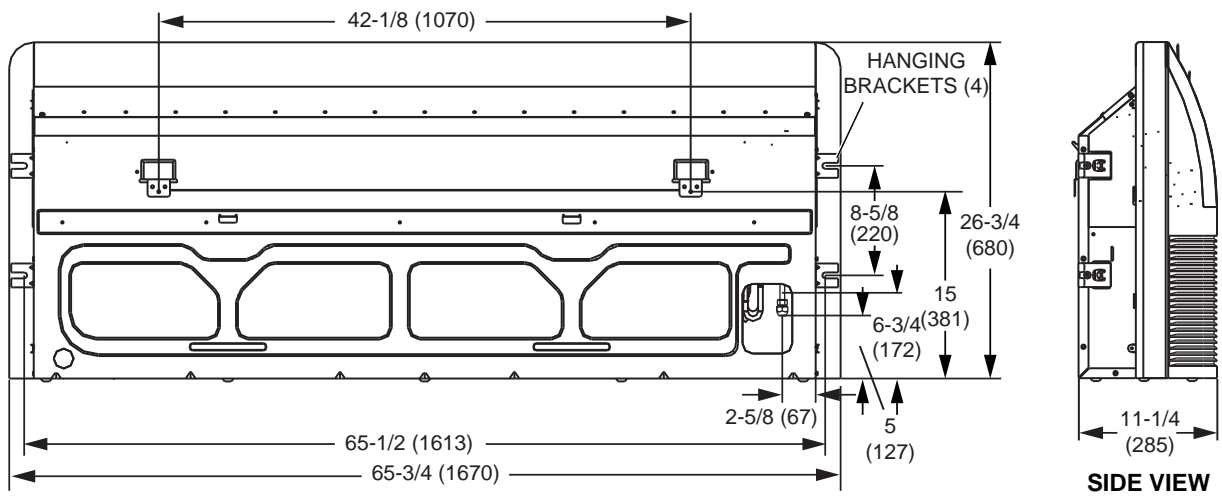

# Clearances

## CEILING APPLICATIONS

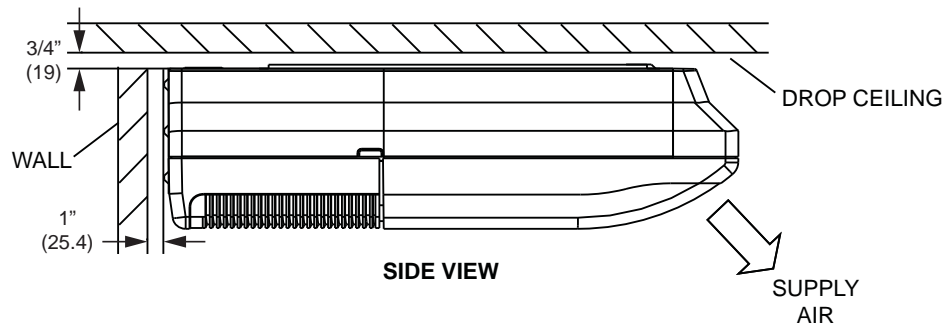

## CEILING AND FLOOR APPLICATIONS

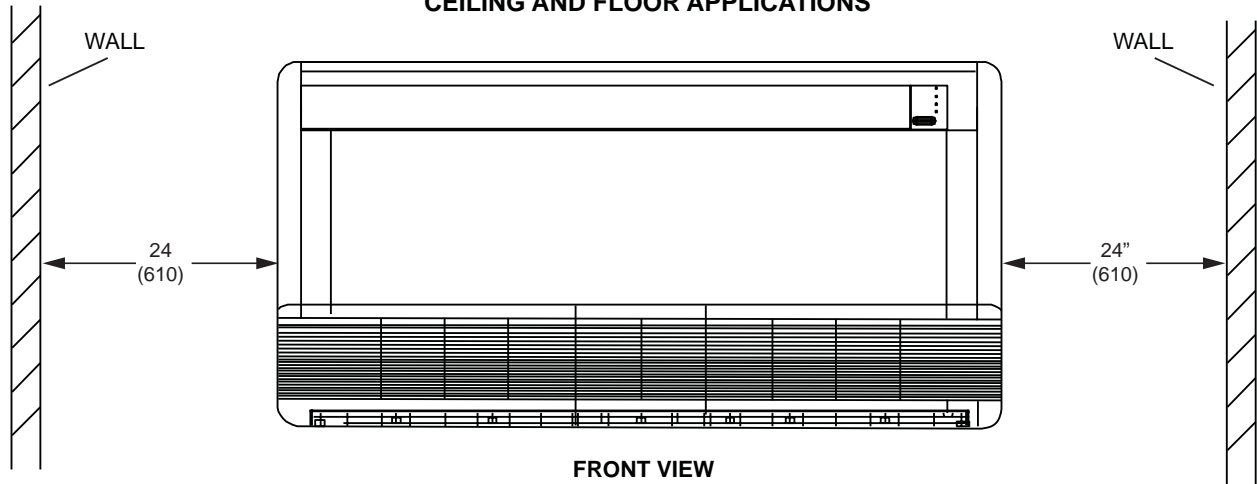

## FLOOR APPLICATIONS

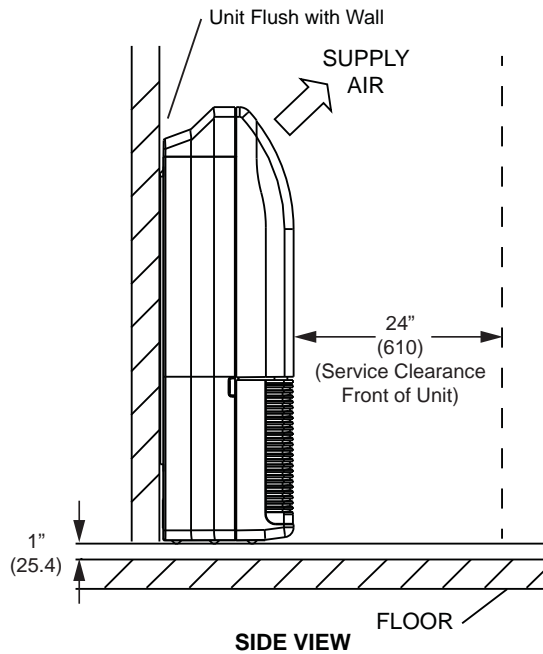

## Unit Placement

In addition to clearances, the following items should be considered:

### ⚠ WARNING

Use the provided and specified components when installing equipment. Failure to do so may result in unit falling, water leaking or electrical shocks, causing personal injury or equipment or property damage. Check stability of wall, floor, or ceiling and unit support. If support is not capable of carrying weight of the unit, unit may fall causing personal injury or equipment damage.

Consider the possibility of earthquakes in your area when installing the equipment. If the unit is not correctly secured, it may fall, causing personal injury or equipment damage.

Safely dispose of packing materials, which include nails, wood and other sharp objects, as well as plastic wrapping. Children playing with plastic wrap or bags risk the danger of suffocation.

### ⚠ CAUTION

Do not place items which may be damaged by water under or around the indoor unit.

The unit should be installed at least 8 feet above the floor (if possible) to ensure maximum performance and comfort, when installed in the horizontal position only.

### AVOID

Do not install the unit in the following locations:

- Areas exposed to petrochemicals or petrochemical products
- Areas exposed to salt or other corrosive materials or caustic gasses
- Areas exposed to extreme voltage variations (such as factories)
- Tightly enclosed areas that may impede service of the unit
- Areas exposed to fossil fuels (such as oil or gas in kitchens)
- Areas exposed to strong electromagnetic forces
- Areas exposed to acids or alkaline detergents (laundry rooms)

### DO:

- Locate the unit so that it is not exposed to direct sunlight
- Locate the indoor unit so that the room can be uniformly cooled. Install unit as high as possible on the ceiling (8 feet above floor, if possible) for best performance (horizontal installation only).
- Ensure the structural wall, floor, or ceiling can support the weight of the unit.

- Select a location where condensate line will have the shortest run to a suitable drain per local codes.
- Allow sufficient space around unit for proper operation and maintenance
- Install unit a minimum of 3 feet away from any antenna, power cord (line) radio, telephone, security system, or intercom. Electrical interference and radio frequencies from any of these sources may affect operation
- Be sure to instruct customers how to properly operate the unit (especially maintenance of air filter, and operation procedure) by having them carry out operations themselves while looking at the manual provided with the controller.

## Installation

### Floor/Wall Applications

1. Locate a suitable position within the space where maintenance access and supply air will not be restricted or affected by obstacles. The minimum clearances are given on page 5.

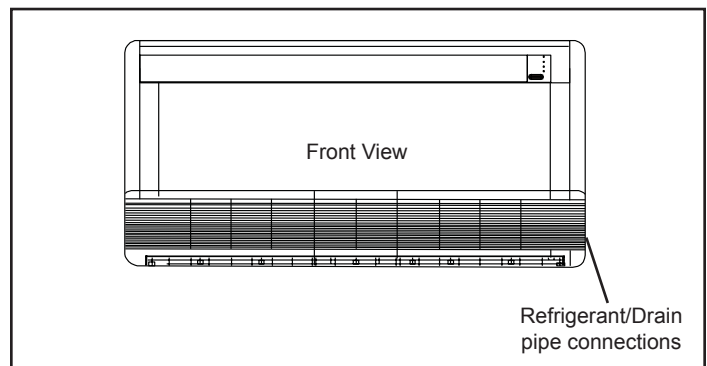

Figure 1. Floor/Wall Applications

2. Locate the VCFA on a wall which is both capable of supporting the unit's weight and which is constructed to enable the unit to fit flush on the wall. An uneven wall may lead to vibration and subsequent unit damage.
3. Use suitable fasteners to secure the two mounting brackets to the wall. See figures 2 and 3, and the dimension drawings on pages 3, 4 and 5 to ensure proper positioning of the brackets.

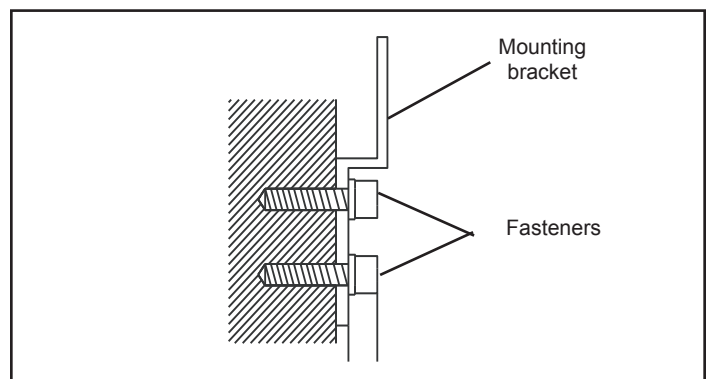
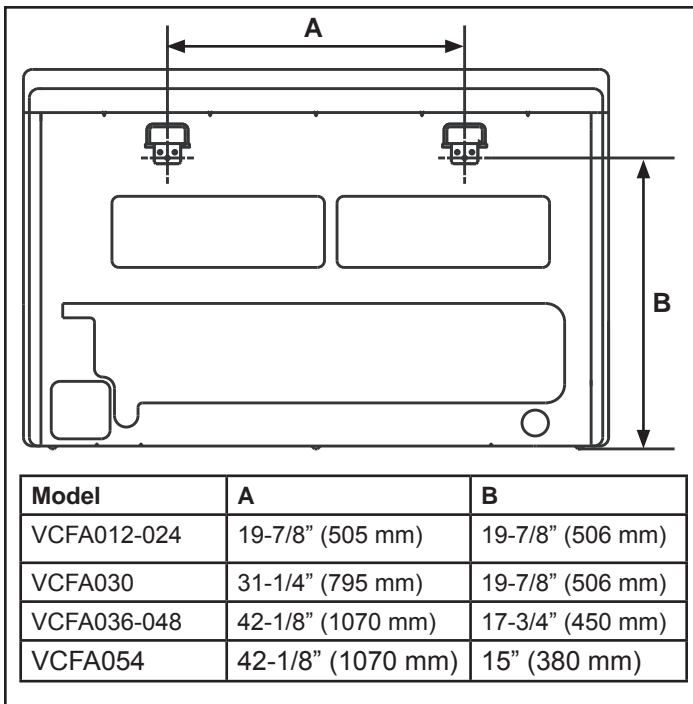

Figure 2. Mounting Brackets

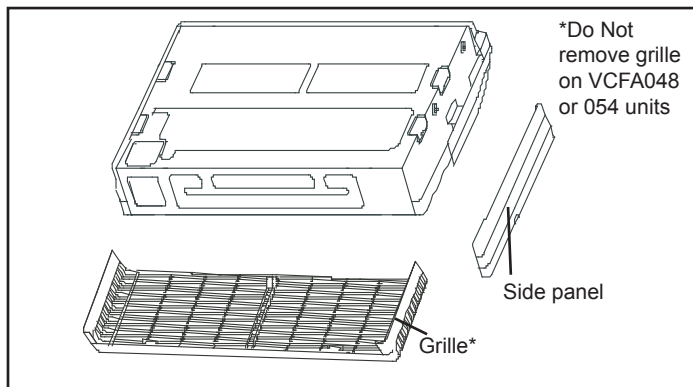

**Figure 3. Mounting Bracket Positioning**

- The unit should be installed high enough for a gravity drain to function properly. If necessary, a field provided external pump can be installed at the unit. See figure 1 for pipe connection locations.
- Upon confirming the two brackets are level, correctly spaced and secured to the wall; lift the unit onto the brackets. Confirm the unit is level before continuing.

#### Ceiling Installation

- Remove the side panel and the grille. See figure 4. *NOTE - Do not remove the grille on VCFA048 or 054 models.*



**Figure 4. Remove Side Panel and Grille**

- Install four factory-provided mounting bolts by screwing them into the provided threaded holes in the unit body. See figure 7 for mounting bolt installation locations. The bolts should only extend from the body a distance which enables the bracket to engage the bolts and secure the unit.
- Make sure that the structural ceiling is able to support the weight of the unit. It may be necessary to add support.

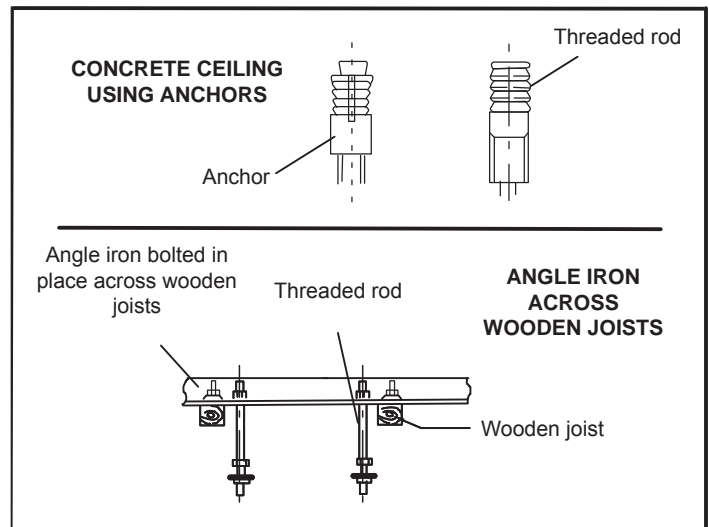

**Figure 5. Locate Threaded Rods**

- Install suspension rods in the structural ceiling or concrete slab in a suitable location. If the structural ceiling is constructed of concrete, install anchors to accept four suitably sized threaded rods to suspend the indoor unit. If the structural ceiling includes wooden joists, use angle iron or Unistrut channel fixed securely in place to accept the threaded rods. See figure 5.
- Slide one nut and one washer onto each threaded rod. Use electrical tape to keep the washer from falling off. Position the nuts slightly above the final resting place of the suspension brackets.

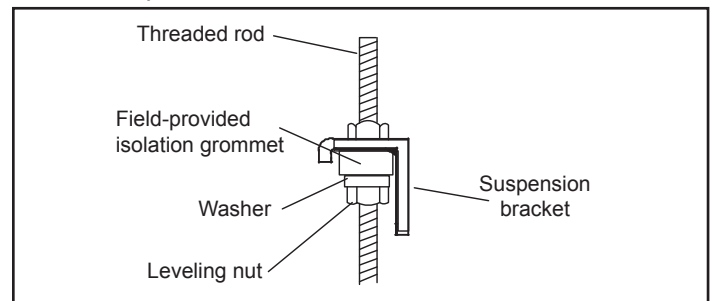

**Figure 6. Locate Suspension Bracket on Threaded Rod**

- VCFA012-048 units:** Afix the two long suspension brackets provided in accessory package to the previously installed threaded rods. See figure 6.
- VCFA054 units:** Afix the four short suspension brackets to the unit body. See figure 7. Install the VCFA054 unit directly onto the threaded rods as instructed in step 8 and then proceed to step 6. Step 9 will not apply to VCFA054 installation.
- Slide a washer and then a nut onto each rod below each suspension bracket. Use the leveling nut (beneath suspension brackets) to adjust the bracket to the correct height. Remove the electrical tape holding the upper washers and nuts in place and tighten each of the four nuts above the brackets down onto the brackets. This will ensure that the unit remains level. See figure 6.
- If necessary, install a field-provided isolation grommet to prevent transmission of vibration from unit to structural ceiling.

9. Use either a mechanical lifting device or a minimum of two people to raise the unit.
10. Hang the unit on the suspension brackets by sliding the unit backwards on the bracket.
11. Securely tighten the mounting bolts on both sides. See figure 7.

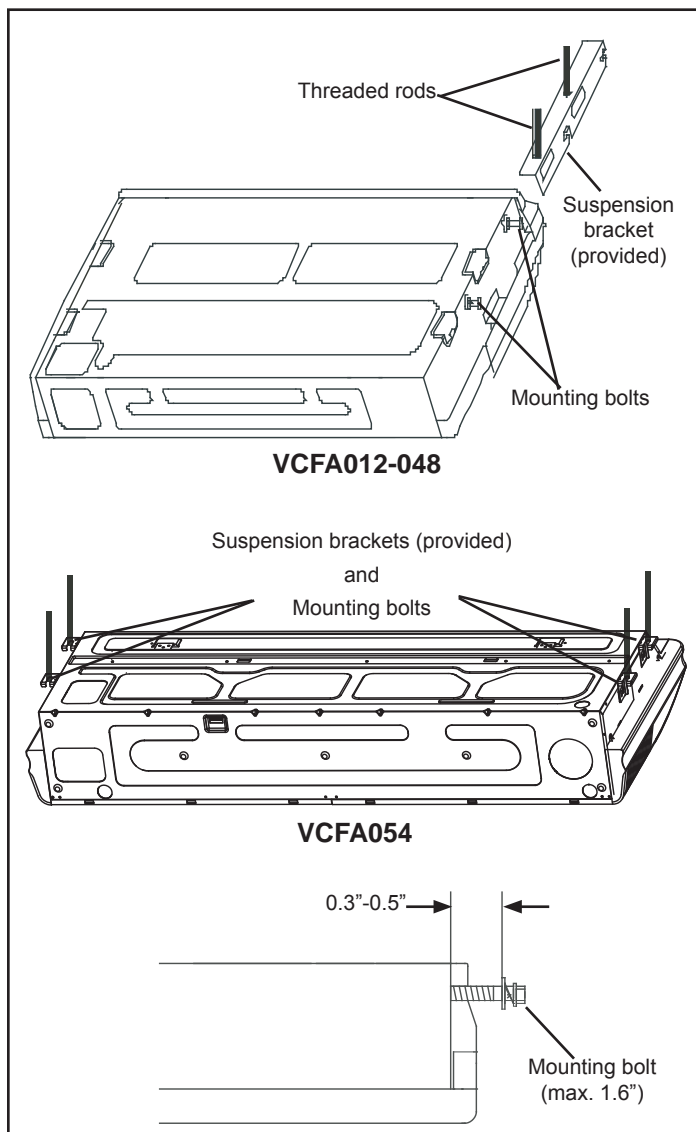

**Figure 7. Suspend Unit**

## Refrigerant Piping Connections

### **⚠ WARNING**

Refrigerant leaks are unlikely; however, if a refrigerant leak occurs, open a door or windows to dilute the refrigerant in the room. Turn off the unit and all other appliances that may cause a spark. Call a licensed professional HVAC technician (or equivalent) to repair the leak.

Use only R410A refrigerant to charge this system. Use of other refrigerant or gas will damage the equipment.

Do not allow air or other contaminants to enter system during installation of refrigerant piping. Contaminants will result in lower system capacity and abnormally high operating pressures and may result in system failure or explosion.

Insulate all refrigerant piping.

Refrigerant pipes may be very hot during unit operation. Do not allow contact between wiring and bare copper pipes.

After refrigerant piping connections have been completed, check the system for leaks per commissioning instructions.

Field piping consists of two copper lines connected to the indoor unit. Table 1 lists the connection sizes at the indoor unit. The connections are made using the provided brass flare nuts at the end of the refrigerant piping connections.

Both lines must be individually insulated.

1. The seal on the unit refrigerant piping connections should remain in place until the last possible moment. This will prevent dust or water from getting into the refrigerant piping before it is connected.
2. CAREFULLY adjust refrigerant piping connections to suit the application.
3. Slowly loosen one of the flare nuts to release the factory nitrogen charge.
4. Remove the flare nuts from the connections on the unit and discard the seal from each of the piping connections.
5. Slide the flare nuts onto the ends of the field-provided refrigerant piping before using a suitable flaring tool to flare the end of the copper pipe.
6. Apply recommended HFC-410A refrigerant lubricant to the outside of the flared refrigerant lines (figure 8-A).



**IMPORTANT!**

The compressor in this unit contains PVE oil (Polyvinylether). PVE oil is formulated for hydrofluorocarbon (HFC) refrigerants, such as R-410a, which this system contains. While it may have some miscibility properties with mineral-based oil and POE oil (Polyolester), it is not recommended to mix PVE oil with any other type of refrigerant oil.

- Align the threaded connections with the flared refrigerant lines. Tighten the flare nuts lightly at first to obtain a smooth match (figure 8-B).

**Table 1. Refrigerant Piping Connections**

Size (Btuh)	Liquid Line	Vapor Line
VCFA012 & 015	1/4"	1/2"
VCFA018 - 054	3/8"	5/8"

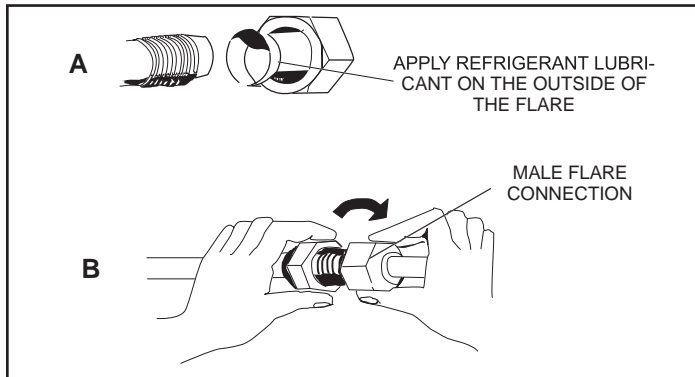
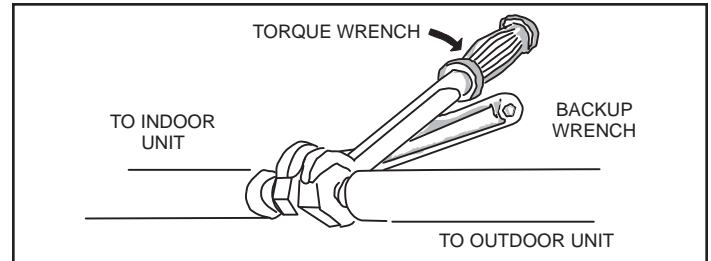

**Figure 8. Making Connections at Indoor Unit (Male to Female Connection)**

- Once snug, continue another half-turn on each nut which should create a leak-free joint. A torque wrench may be used to tighten flare nuts using table 2 recommendations. See figure 7. **Do not over-tighten a flared joint. Flared connections should always be accessible and must be insulated to prevent condensation.**

**IMPORTANT!**

**Always use two wrenches when tightening flare nuts to avoid twisting refrigerant piping. DO NOT over-tighten flare nuts.**



**Figure 9. Tighten Flare Nut**

**Table 2. Flare Nut Torque Recommendations**

Outside Diameter	Recommended Torque	No torque wrench available Finger tighten and use an appropriately sized wrench to turn an additional:
Inches	U.S.	
1/4"	15 ft.-lb.	1/4 turn
3/8"	26 ft.-lb.	1/2 turn
1/2"	41 ft.-lb.	7/8 turn
5/8"	48 ft.-lb.	1 full turn

- After refrigerant piping has been installed and checked for leaks, apply insulation over all flared connections.

## Condensate Piping Connections

### ⚠ CAUTION

Make sure that drain piping is properly routed and insulated in order to prevent both leaks and condensation.

1. Make a water-tight connection between the field-provided condensate drain extension and the provided flexible drain piping.
2. Confirm proper slope (not less than 1/4 inch per foot) and routing of condensate lines to ensure moisture is drained away from the indoor unit.
3. Drain should be as short as possible and should not have any droops or kinks that would restrict condensate flow and shall be approved resistant pipe. There must be a 2-inch space between the end of the condensate drain and the final termination point (ground, open drain, etc.) to ensure that the line will drain freely.
4. After the system installation is complete, the condensate drain line must be checked for leaks and proper drainage. If a field-provided condensate pump has been installed, it must be checked to ensure proper operation. This check is part of the commissioning sequence.

## IMPORTANT!

Drain should have a slope of at least 1/4 inch per foot and should be approved corrosion-resistant pipe. You must confirm operation of every drain and pump in the system as part of the commissioning procedure.

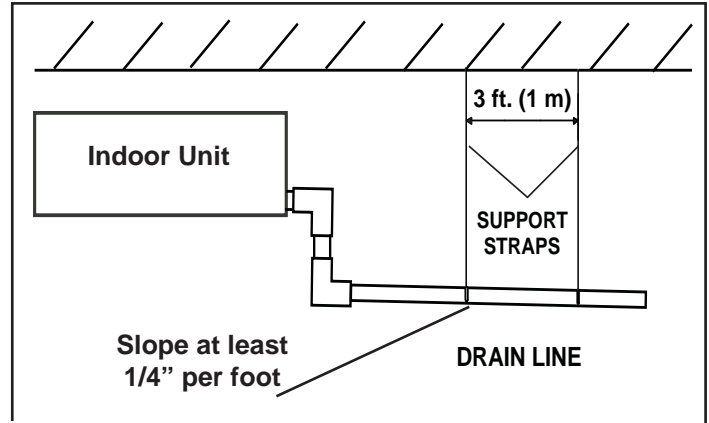

Figure 10. Single Indoor Unit Suspended from Ceiling Using a Properly Sloped Gravity Drain

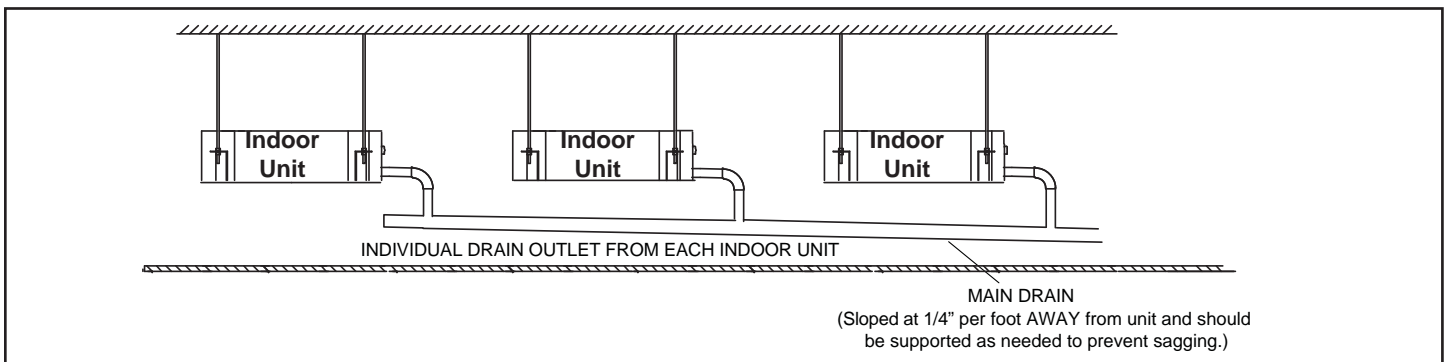

Figure 11. Condensate Drain Multiple Indoor Units Suspended from Ceiling Using a Single Properly Sloped Gravity Drain

## Wiring Connections

### ⚠ WARNING

Isolate the power supply before accessing unit electrical terminals.

Install unit so that unit disconnect is accessible.

Follow all local and national codes, as well as this installation instruction, during installation. Do NOT overload electrical circuit, as this may lead to failure and possible fire.

Use specified wiring and cable to make electrical connections. Clamp cables securely and make sure that connections are tight to avoid strain on wiring. Insecure wiring connections may result in equipment failure and risk of fire.

Wiring must be installed so that all cover plates can be securely closed.

### ⚠ CAUTION

This unit must be properly grounded and protected by a circuit breaker. The ground wire for the unit must not be connected to a gas or water pipe, a lightning conductor or a telephone ground wire.

Do not connect power wires to the outdoor unit until all other wiring and piping connections have been completed.

Install all wiring at least 3 feet away from televisions, radios or other electronic devices in order to avoid the possibility of interference with the unit operation. Do not install the unit near a lighting appliance that includes a ballast. The ballast may affect remote control operation.

### ⚠ CAUTION

A disconnection device having an air gap contact separation in all active conductors should be incorporated in the fixed wiring according to the National Wiring Regulation.

In the U.S.A., wiring must conform with current local codes and the current National Electric Code (NEC). In Canada, wiring must conform with current local codes and the current Canadian Electrical Code (CEC). Refer to unit nameplate for minimum circuit ampacity and maximum overcurrent protection size.

*NOTE - Three-conductor shielded cable must be used for the communication wiring. This is necessary to ensure proper system communication and operation.*

- A circuit breaker capable of shutting down the power supply to the entire system must be installed.
- A single switch can be used to supply power to units on the same system. However, branch switches and circuit breakers must be selected carefully.

- Fit the power supply wiring of each unit with a switch and fuse as shown in the wiring diagram.
- Install a wiring interrupter or ground-fault circuit interrupter for the power wiring.
- Make sure the ground resistance is no greater than 100Ω. This value can be as high as 500Ω when using a grounding fault circuit interrupter since the protective ground resistance can be applied.

1. Pull the return air filter grille forward and remove the filters.
2. Remove one screw from each safety strap assembly (one on each side) and remove return air grille.
3. Locate the control box in the center of the unit, below and behind the fan motor.
4. Remove the two screws holding the control box onto the motor mounting bracket, and the screw at each end of the control box holding securing the box to the chassis of the unit. Lower the control box to obtain access to cover.
5. Remove the screws securing the cover and remove cover from control box.
6. Locate the terminal strip in the control box. Connect the power wiring (sized per NEC/CEC and local codes) and communications cable (three-conductor shielded cable) per figures 12 and 13. Refer to unit nameplate for rated voltage.
7. If the indoor unit is the final unit in a group that is wired in series, install the provided resistor across terminals P and Q. See figure 14.

### Tightening torque for the terminal screws

- Use the correct screwdriver for fighting the terminal screws. If the screwdriver blade is too small, the head of the screw might be damaged, and the screw will not be properly tightened.
- If the terminal screws are over tightened, screws might be damaged.
- Refer to the table below for the tightening torque of the terminal screws.

**Table 3. Terminal Screw Tightening Torque**

	Tightening torque (lb-ft)
Terminal base of remote controller/Signal transmission wire (X2M)	0.58-0.72
Terminal base of power supply (X1M)	0.87-1.06
Grounding terminal (M4)	1.06-1.43

- After wiring, confirm all connections are correct; Then turn on power supply to the unit.

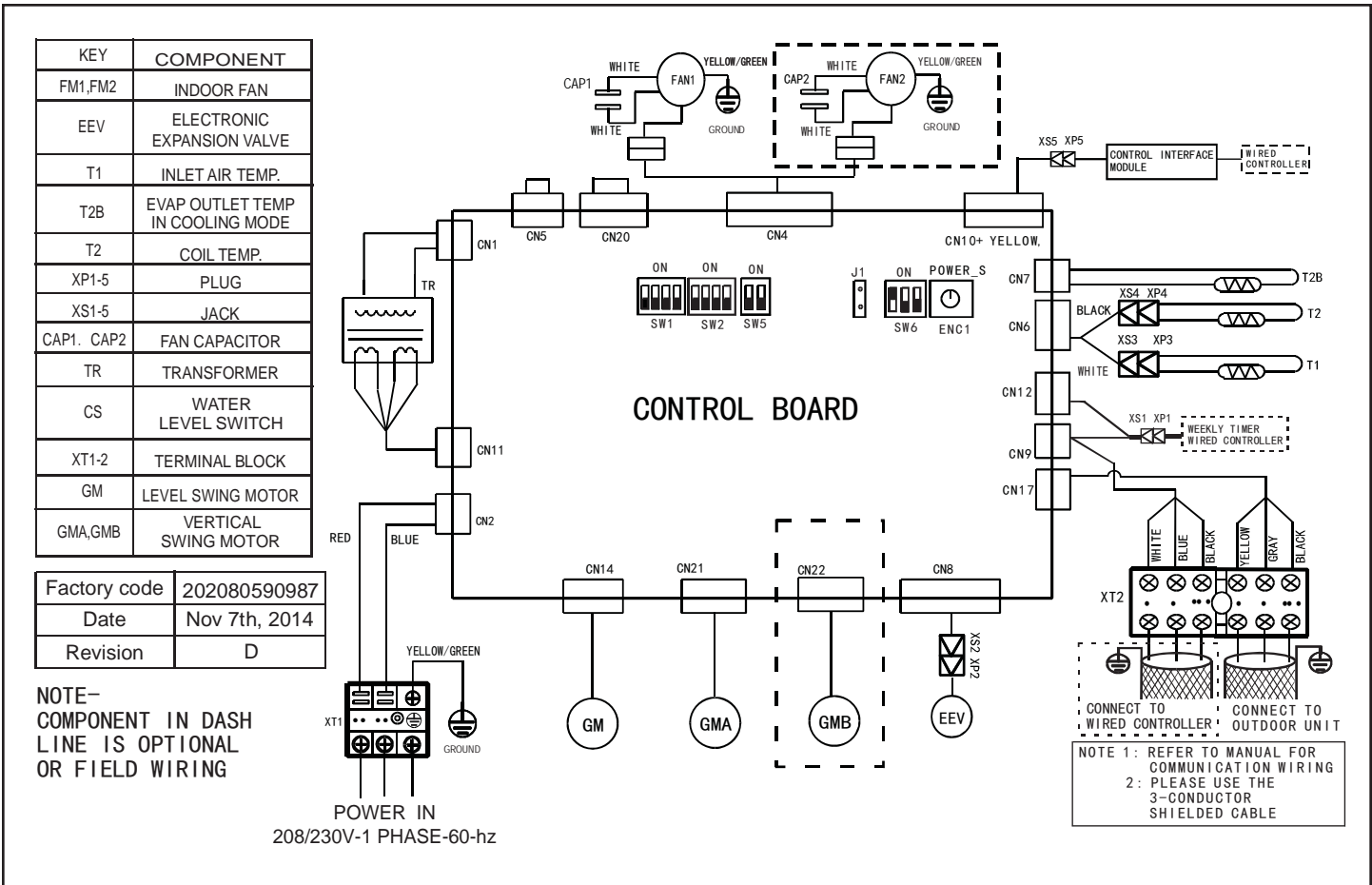

Figure 12. VCFA012-48 Wiring Diagram

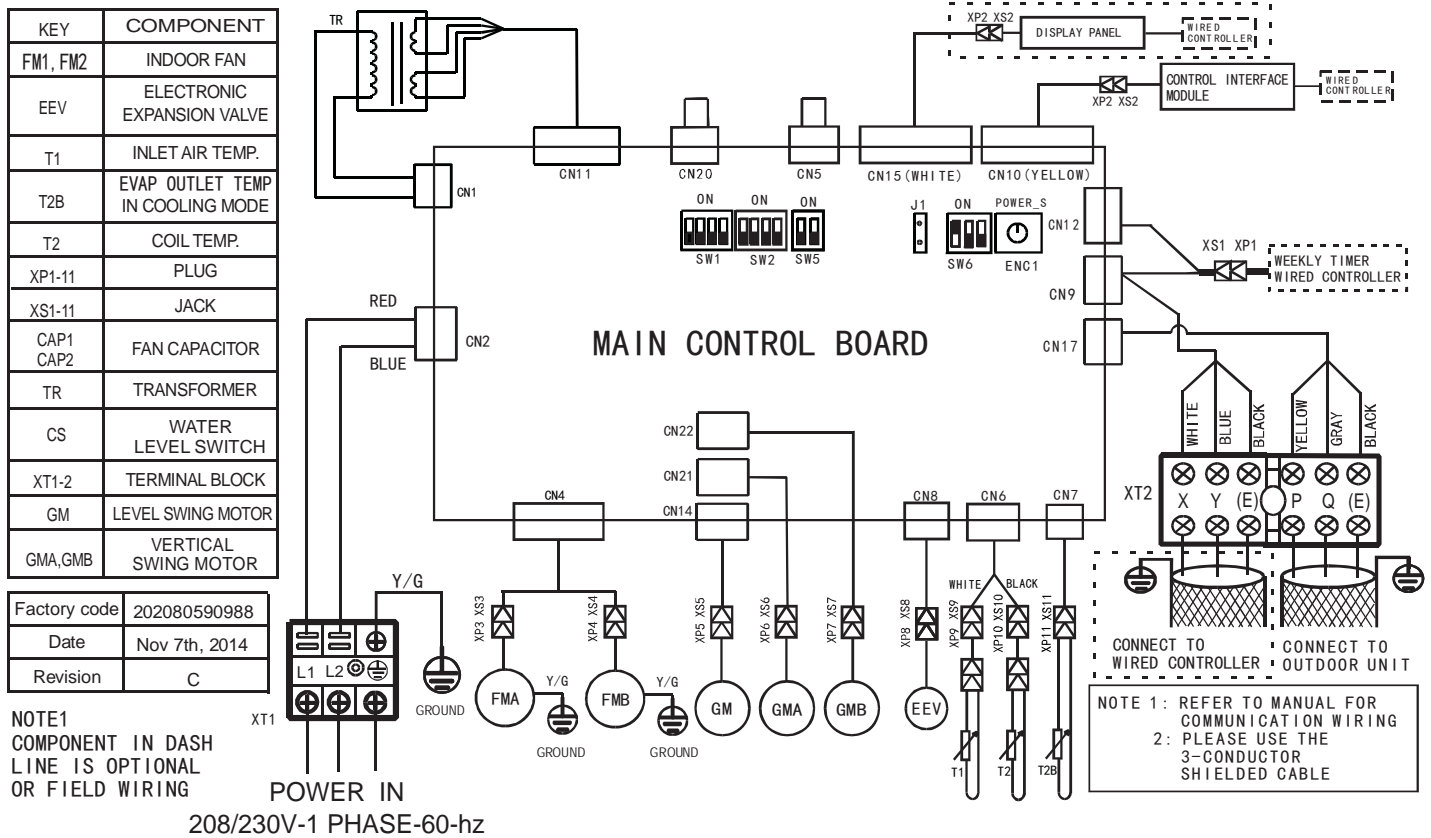

Figure 13. VCFA054 Wiring Diagram

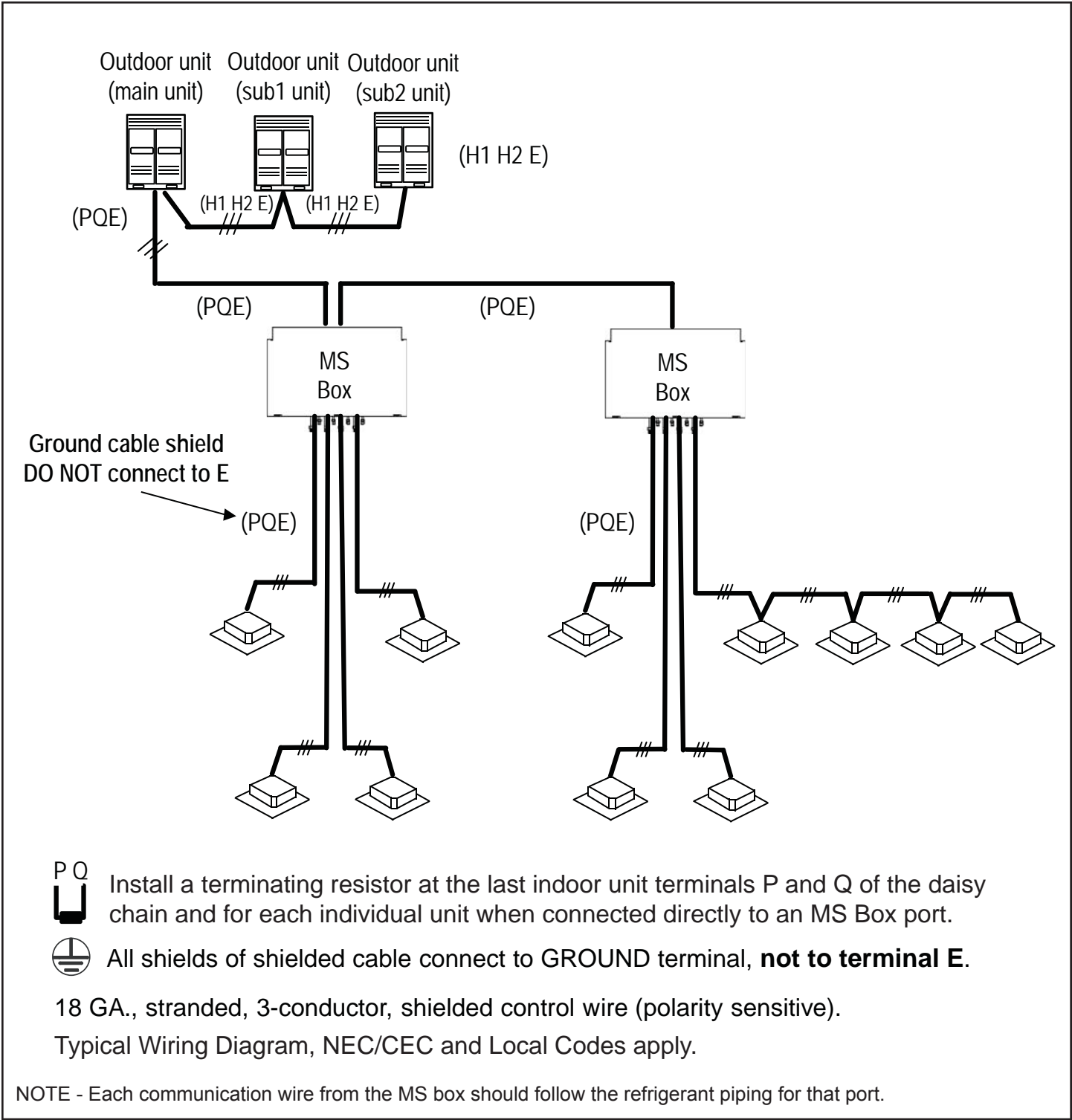

Figure 14. Typical Communication Wiring Diagram (VRF Heat Recovery System)