



©2014 Lennox Industries Inc.  
Dallas, Texas, USA

# INSTALLATION INSTRUCTION

## VHIA High-Static Ducted Units

VRF SYSTEMS  
DUCTED INDOOR UNITS  
507445-01  
10/2014



### THIS MANUAL MUST BE LEFT WITH THE OWNER FOR FUTURE REFERENCE

These instructions are intended as a general guide and do not supersede local codes in any way. Consult authorities having jurisdiction before installation.

## ⚠ WARNING

Improper installation, adjustment, alteration, service or maintenance can cause property damage, personal injury or loss of life.

Installation and service must be performed by a licensed professional HVAC installer, service agency or the gas supplier.

Failure to follow safety warnings and these instructions exactly could result in property damage, dangerous operation, serious injury, or death.

Any additions, changes, or conversions required in order for the appliance to satisfactorily meet the application needs must be made by a licensed professional HVAC installer (or equivalent) using factory-specified parts.

Do not use this system if any part has been under water. A flood-damaged appliance is extremely dangerous. Immediately call a licensed professional HVAC service technician (or equivalent) to inspect the system and to replace all controls and electrical parts that have been wet, or to replace the system, if deemed necessary.

The State of California has determined that this product may contain or produce a chemical or chemicals, in very low doses, which may cause serious illness or death. It may also cause cancer, birth defects, or reproductive harm.

## ⚠ CAUTION

As with any mechanical equipment, personal injury can result from contact with sharp sheet metal edges. Be careful when you handle this equipment.

## ⚠ IMPORTANT

The Clean Air Act of 1990 bans the intentional venting of refrigerant (CFCs, HCFCs and HFCs) as of July 1, 1992. Approved methods of recovery, recycling or reclaiming must be followed. Fines and/or incarceration may be levied for noncompliance.

These units must be installed as a part of a matched system as specified in the Product Specifications (EHB) bulletin.

### General

The VHIA high-static, ducted indoor units are matched with an outdoor heat recovery or heat pump unit to create a VRF (variable refrigerant flow) system that uses HFC-410A refrigerant.

Refer to the Product Specification bulletin (EHB) for the proper use of these indoor units with specific heat pumps, heat recovery units, mode switching devices, branch pipes, line sets and controls.

These instructions are intended as a general guide and do not supersede local or national codes in any way. Authorities having jurisdiction should be consulted before installation.

### Shipping and Packing List

Check the components for shipping damage. If you find any damage, immediately contact the last carrier.

Package 1 of 1 contains the following:

1 - Assembled medium static, concealed duct unit

Condensate drain insulation sleeves

2 - VHIA 024 through 054 units

4 - VHIA 072 and 096 units

1 - Flexible condensate connector

1 - Hose clamp

Nuts

1 - VHIA 024 through 054 units

2 - VHIA 072 and 096 units)

1 - Cable

1 - Roll tap

1 - Resistor

1 - Installation manual

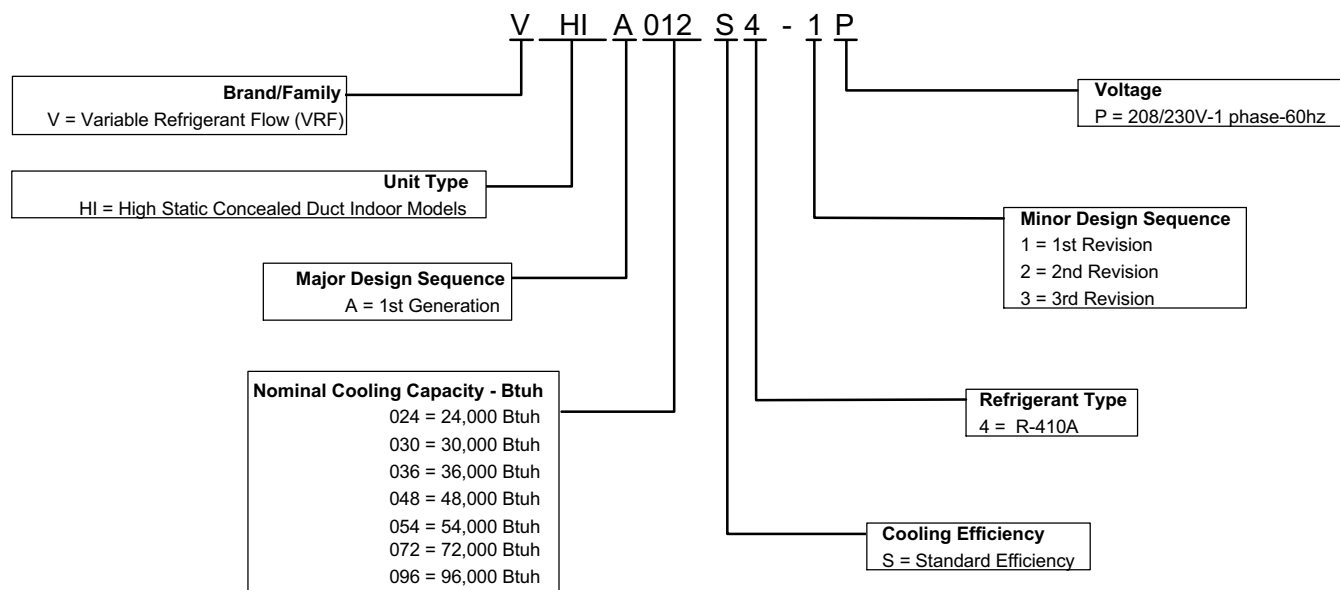
**Safety Requirements**

**⚠ WARNING**

**ELECTRICAL SHOCK, FIRE, OR EXPLOSION HAZARD.**

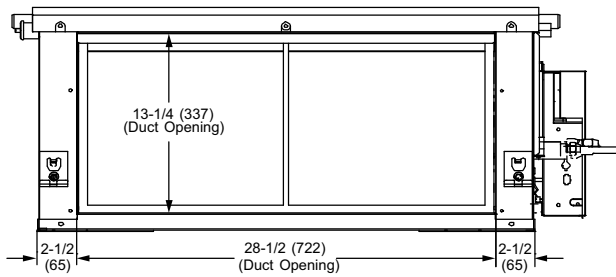
- Do not touch the unit or the controller if your hands are wet.
- Do not use combustible materials (hair spray, paint, etc.) near the unit.
- Do not use spray insecticide near the unit.
- Do not operate appliances with an open flame near the unit.
- DO NOT spray water on the indoor unit for any reason.
- Do not replace a fuse with a fuse of a different rating. Do not use a jumper wire to replace a fuse.
- Do not insert your hands, tools or any other item into the air intake or air outlet at either the indoor or outdoor unit.
- Do not allow children to operate the system.

**Model Number Identification**

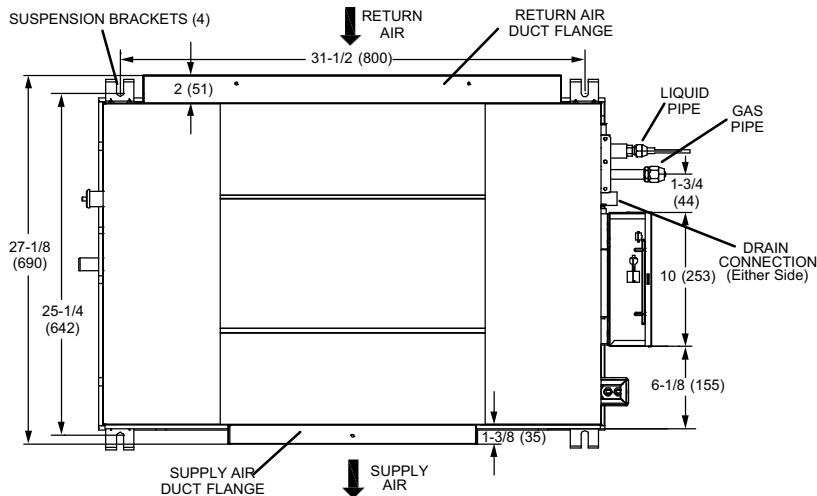


# Unit Dimensions - inches (mm)

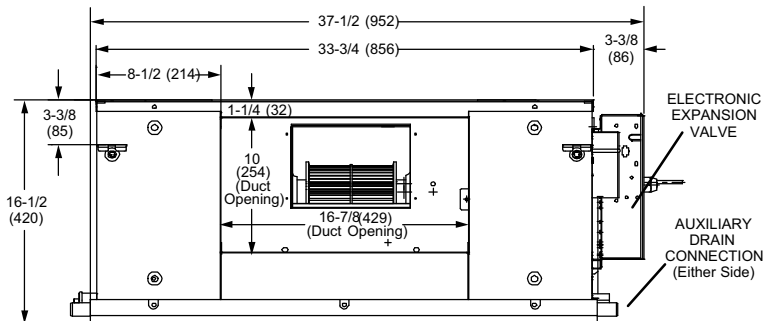
VHIA024S4, VHIA030S4, VHIA036S4



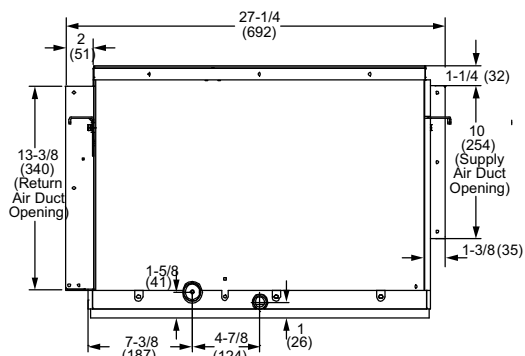
**RETURN AIR VIEW**



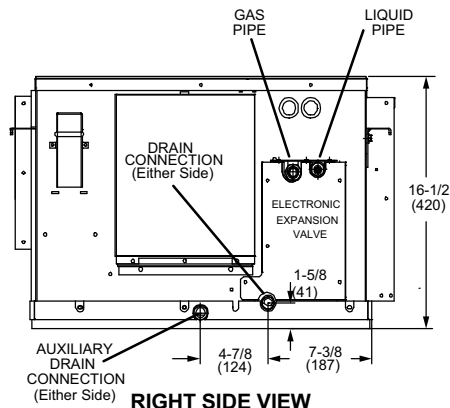
**TOP VIEW**



**SUPPLY AIR VIEW**

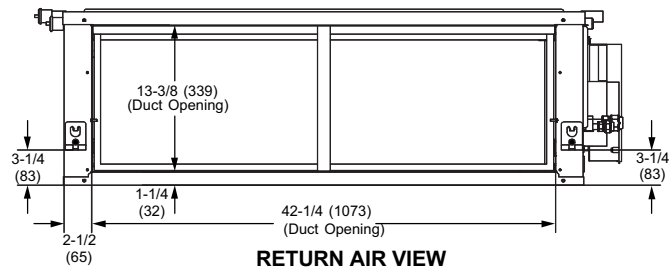


**LEFT SIDE VIEW**

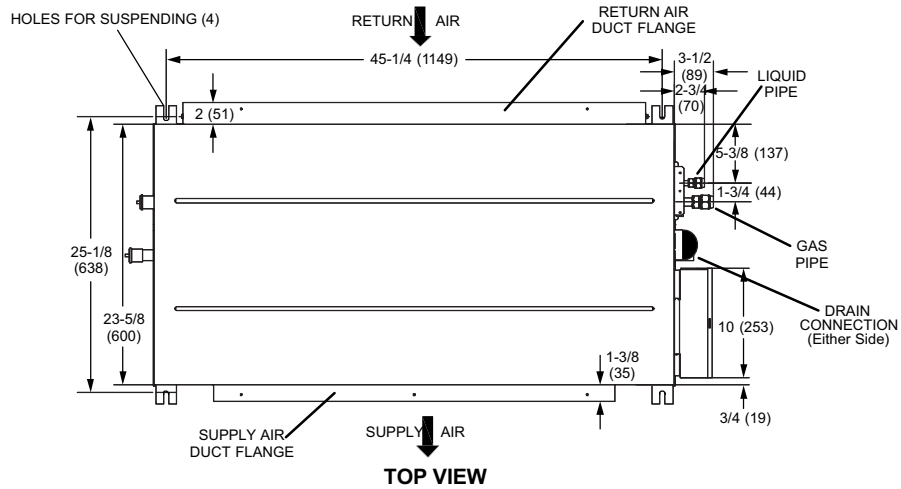


**RIGHT SIDE VIEW**

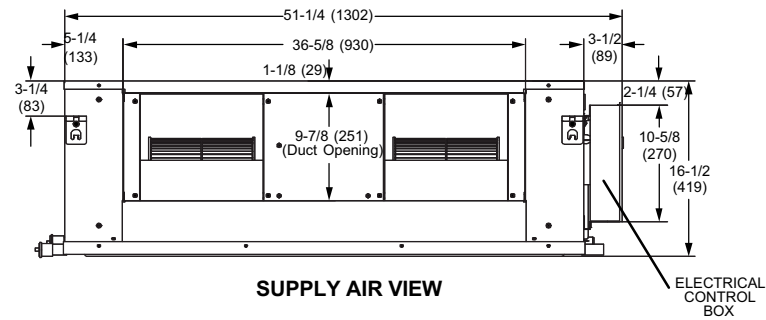
VHIA048S4, VHIA054S4



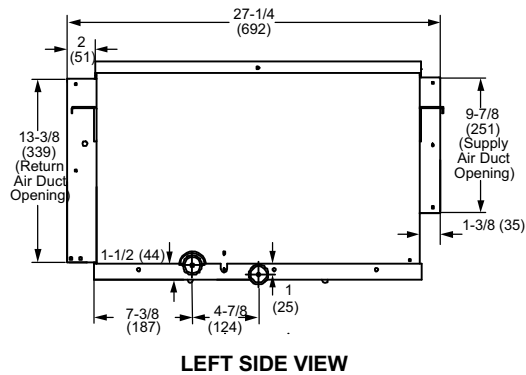
RETURN AIR VIEW



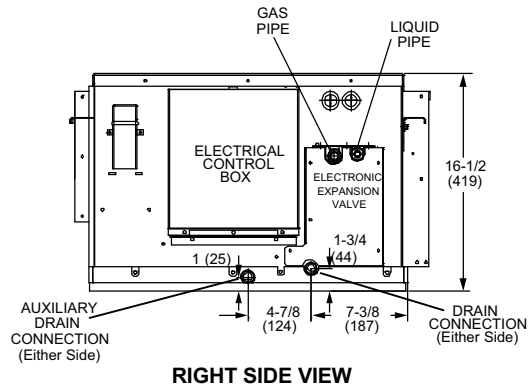
TOP VIEW



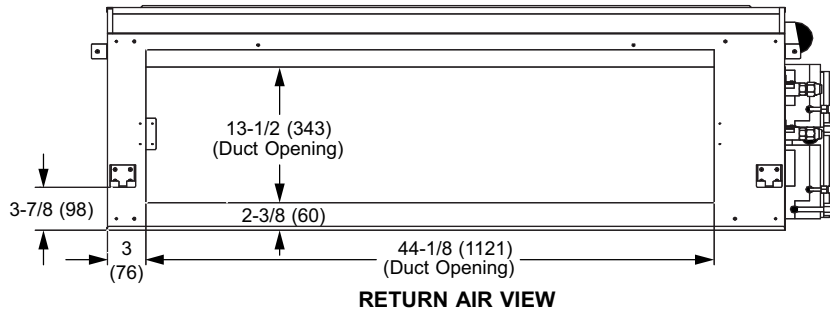
SUPPLY AIR VIEW



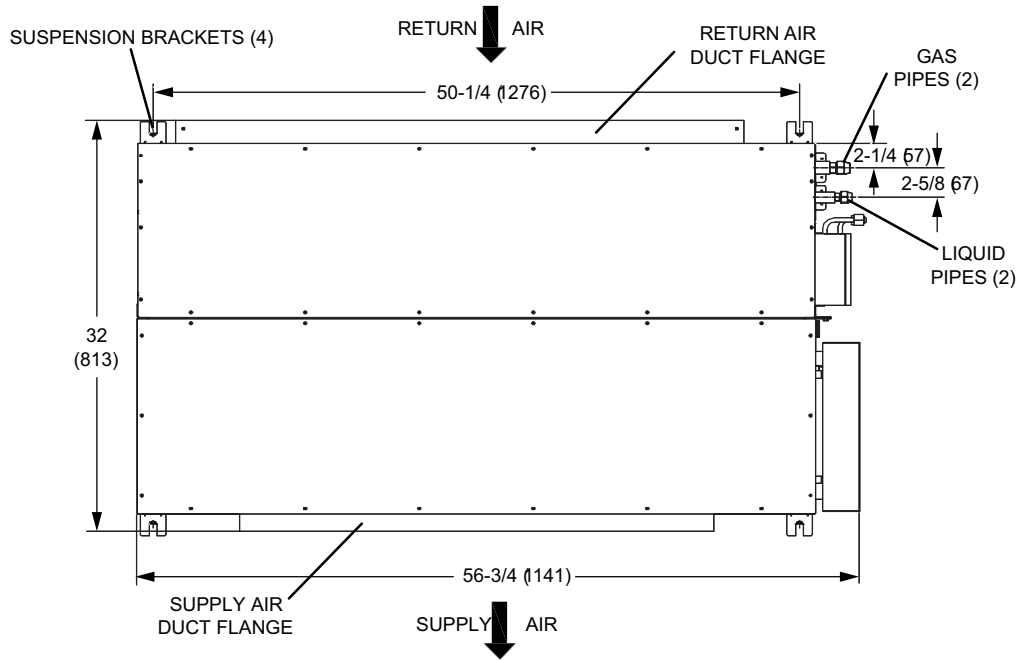
LEFT SIDE VIEW



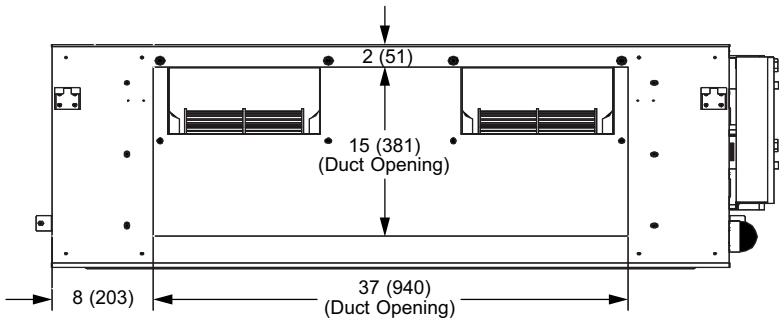
RIGHT SIDE VIEW



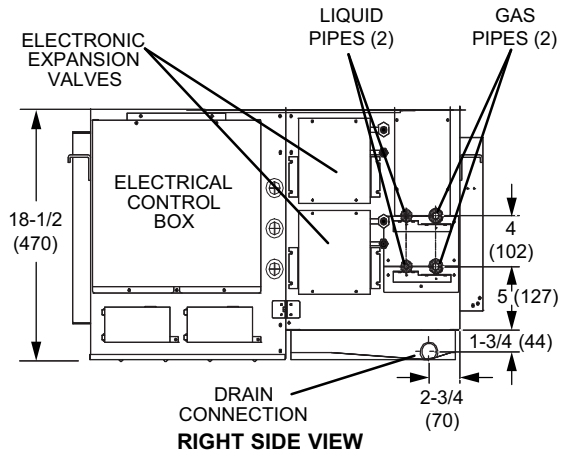
**RETURN AIR VIEW**



**TOP VIEW**



**SUPPLY AIR VIEW**



**RIGHT SIDE VIEW**

## Clearances

Refer to figure 1 for minimum clearance requirements.

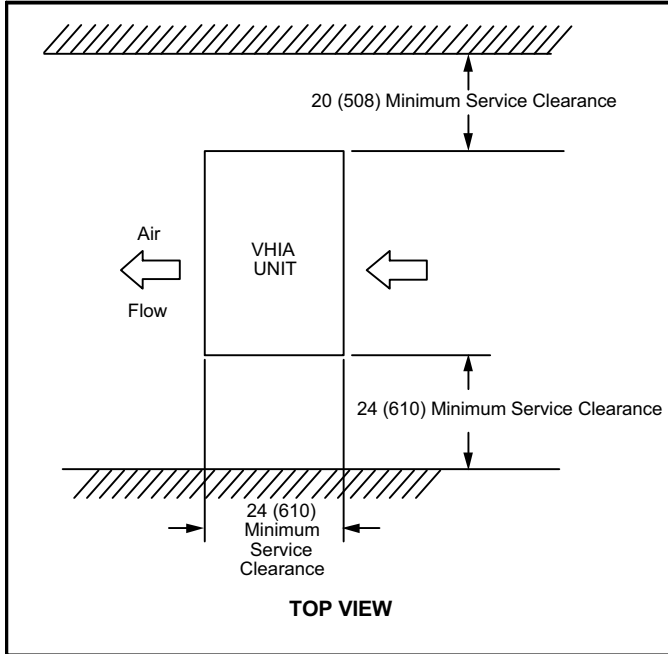


Figure 1. Minimum Installation Clearances

## Indoor Unit Placement

In addition to clearances, the following items should be considered:

## ⚠ WARNING

Use the provided and specified components when installing equipment. Failure to do so may result in unit falling, water leaking or electrical shocks, causing personal injury or equipment or property damage.

Check stability of ceiling and unit support. If support is not capable of carrying weight of the unit, unit may fall causing personal injury or equipment damage.

Safely dispose of packing materials, which include nails, wood and other sharp objects, as well as plastic wrapping. Children playing with plastic wrap or bags risk the danger of suffocation.

## ⚠ CAUTION

Do not place items which may be damaged by water under or around the indoor unit.

The unit should be installed at least 8 feet above the floor (if possible) to ensure maximum performance and comfort.

### AVOID

Do not install the unit in the following locations:

- Areas exposed to salt or other corrosive materials or caustic gases
- Areas exposed to extreme voltage variations (such as factories)
- Tightly enclosed areas that may impede service of the unit
- Areas exposed to strong electromagnetic forces
- Areas exposed to acids or alkaline detergents (laundry rooms)

### DO:

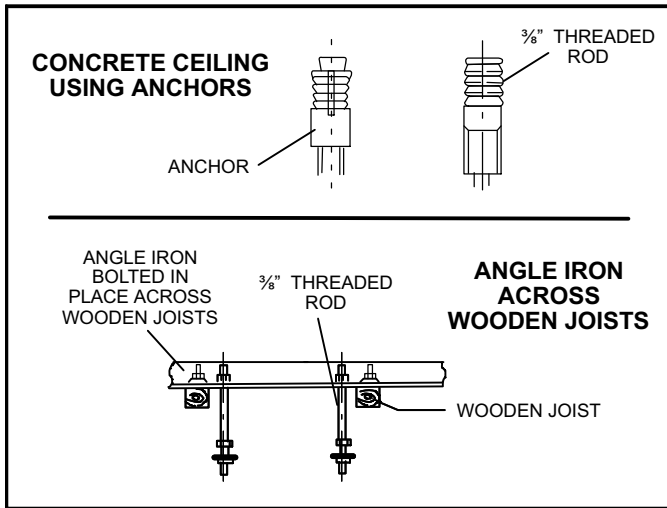
- Locate the unit so that it is central to the area being conditioned.
- Locate the unit so that it is not exposed to direct sunlight.
- Locate the indoor unit so that the room can be uniformly cooled.
- Select a ceiling location that can support the weight of the unit.
- Select a location where condensate line will have the shortest run to the outside of the structure or to a suitable drain per local codes.
- Allow sufficient space around unit for proper operation and maintenance (filter must be able to be removed from the bottom of the unit).
- Install the indoor unit a minimum of 3 feet away from any antenna, power cord (line), radio, telephone, security system, or intercom. Electrical interference and radio frequencies from any of these sources may affect operation.

## Installation

It is important to locate the unit where it can be accessed for service in the future. Refer to unit dimensions on Page 3 for exact locations of suspension brackets, return air and supply air openings.

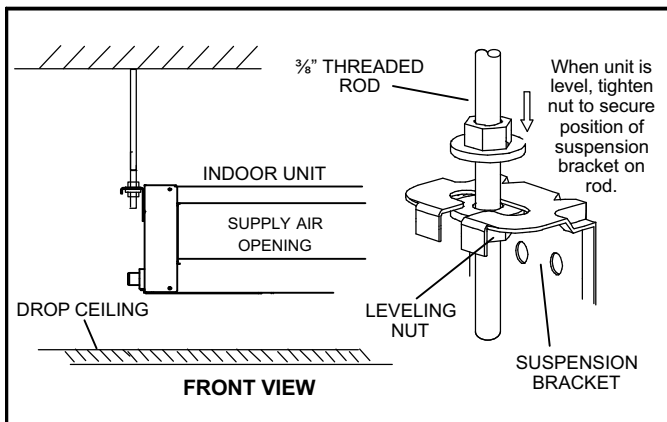
- 1 - **Make sure that the structural ceiling is able to support the weight of the indoor unit. It may be necessary to add extra support.**
- 2 - Install suspension rods in the structural ceiling or concrete slab in a suitable location.  
If the structural ceiling is constructed of concrete,

install anchors to accept four 3/8" threaded rods to suspend the indoor unit. If the structural ceiling includes wooden joists, use angle iron or Unistrut channel fixed securely in place to accept the 3/8" threaded rods. See figure 2.

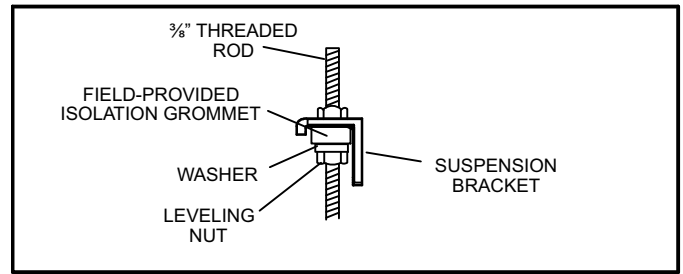


**Figure 2. Suspending Methods**

- 3 - Slide one nut and one washer onto each threaded rod. Use electrical tape to keep the washer from falling off. Position the nuts slightly above the final resting place of the four suspension brackets. See figure 2.
- 4 - Use either a mechanical lifting device or a minimum of two people to raise the unit and insert the threaded rods into the suspension brackets on the indoor unit. Slide a washer and then a nut below the suspension bracket on each rod. Use the leveling nut (at the bottom) to adjust the height of the indoor unit until it is level. Remove the electrical tape holding the washers and nuts in place above the suspension brackets. Tighten each of the four nuts down onto the brackets. This will ensure that the unit remains level.



**Figure 3. Suspension Hardware**



**Figure 4. Isolation Grommet**

- 5 - If necessary, install a field-provided isolation grommet as shown in figure 4 to prevent transmission of vibration from unit to structural ceiling.
- 6 - If the unit is being installed in an application that includes a sheet rock (plasterboard) ceiling, it is recommended to install an access panel in a suitable location to allow final connection of the refrigerant piping, condensate line and electrical connections. This will also allow access for future maintenance.
- 7 - The unit is factory-configured for the supply air to be delivered from the front and the return air filter at the rear of the unit.

**INSTALLATION GUIDELINES**

- Install a field-provided isolation grommet as shown in figure 4 to prevent transmission of vibration from unit to structural ceiling.
- Provide separate support for the weight of the duct system. Duct system must not be supported by the indoor unit.
- Use flexible joints (canvas) at the point where the duct connects to the unit on both ends. Material must meet all local and national code requirements.
- When unit is being installed in a location where even the slightest noise would be a problem (meeting room or other very quiet space), design duct system to avoid transmission of vibration to the structure to the extent possible.

## Refrigerant Piping Connections

### ⚠ WARNING

Refrigerant leaks are unlikely; however, if a refrigerant leak occurs, open a door or windows to dilute the refrigerant in the room. Turn off the unit and all other appliances that may cause a spark. Call a licensed professional HVAC technician (or equivalent) to repair the leak.

Use only R410A refrigerant to charge this system. Use of other refrigerant or gas will damage the equipment.

Do not allow air or other contaminants to enter system during installation of refrigerant piping. Contaminants will result in lower system capacity and abnormally high operating pressures and may result in system failure or explosion.

Insulate all refrigerant piping.

Refrigerant pipes may be very hot during unit operation. Do not allow contact between wiring and bare copper pipes.

After refrigerant piping connections have been completed, check the system for leaks per commissioning instructions.

Field piping consists of two copper lines connected to the indoor unit. Table 1 lists the connection sizes at the indoor unit. The connections are made using the provided brass flare nuts at the end of the refrigerant piping connections. **Both lines must be individually insulated.**

**NOTE** - Always slide a flare nut onto the field-provided refrigerant piping before flaring the lines.

- 1 - The seal on the unit refrigerant piping connections should remain in place until the last possible moment. This will prevent dust or water from getting into the refrigerant piping before it is connected.
- 2 - Slowly loosen one of the flare nuts to release the factory nitrogen charge.
- 3 - Remove the flare nuts and discard the seal from each of the piping connections.
- 4 - Slide the flare nuts onto the ends of the field-provided refrigerant piping **before** using a suitable flaring tool to flare the end of the copper pipe.
- 5 - Apply recommended HFC-410A refrigerant lubricant to the outside of the field-provided flared line sets (figure 5 -- A).

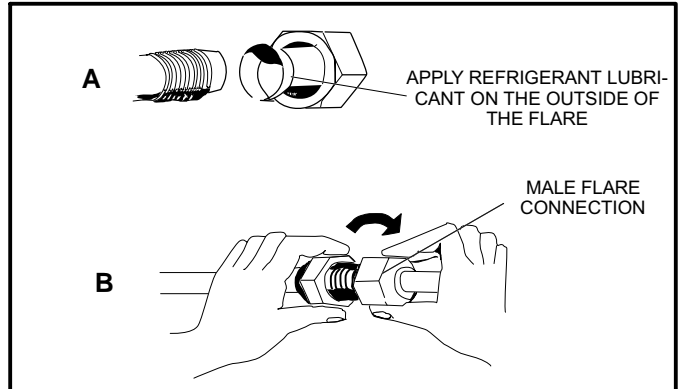
### IMPORTANT !

**Mineral oils are not compatible with HFC-410A.**

- 6 - Align the union tube and flared refrigerant lines with each other, then tighten the flare nuts lightly at first to obtain a smooth match (figure 5 -- B).

**Table 1. Refrigerant Piping Connections**

System Size (Btuh)	Liquid Line	Vapor Line
24000 30000 36000 48000 54000	3/8 in.	5/8 in.
72000 96000	3/8 in. (2)	5/8 in. (2)



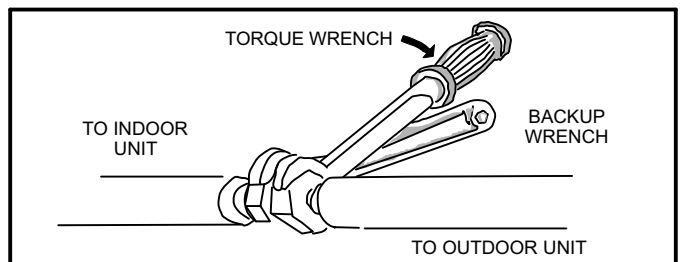
**Figure 5. Making Connections at Indoor Unit (Male to Female Connection)**

- 7 - Once snug, continue another half-turn on each nut which should create a leak-free joint. A torque wrench may be used to tighten flare nuts using table 2 recommendations. (see figure 6). **Do not over-tighten a flared joint.**

**Flared connections should always be accessible and must be insulated to prevent condensation. See figure 7.**

### IMPORTANT !

**Always use two wrenches when tightening flare nuts to avoid twisting refrigerant piping. DO NOT over-tighten flare nuts.**

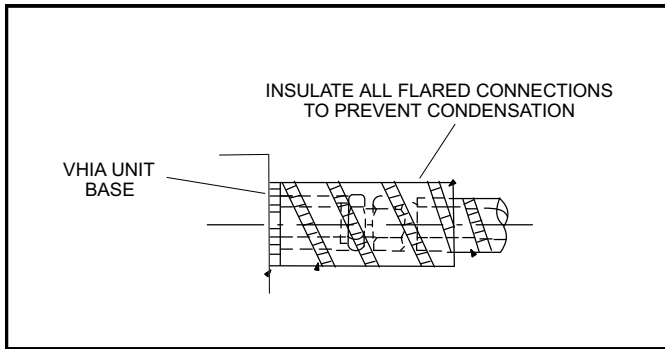


**Figure 6. Tighten Flare Nut**

**Table 2. Flare Nut Torque Recommendations**

Outside Diameter	Recommended Torque	No torque wrench available Finger tighten and use an appropriately sized wrench to turn an additional:
Inches	U.S.	
3/8"	26 ft.- lb.	1/2 turn
5/8"	48 ft.- lb.	1 full turn





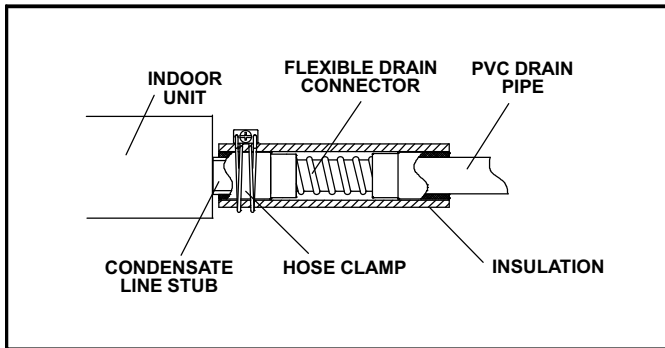
**Figure 7. Insulate Flared Connections**

- 8 - After refrigerant piping has been installed and checked for leaks, apply insulation over all flared connections.

**Condensate Drain Connections**

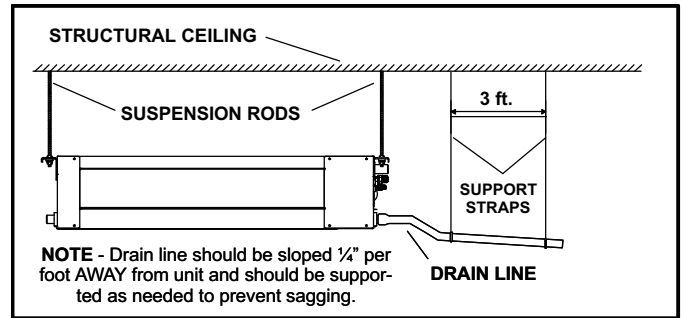
**CAUTION**  
 Make sure that drain piping is properly routed and insulated in order to prevent both leaks and condensation. Follow these instructions exactly to ensure proper drainage and unit operation.

- 1 - Use the provided hose clamp to secure the provided flexible condensate drain connector and insulating sleeve to the drain line stub on the side of the indoor unit. See figure 8.  
**NOTE** - Take care not to over-tighten the hose clamp as this may damage the drain line stub.



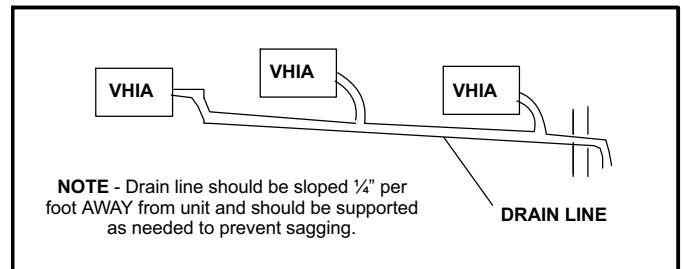
**Figure 8. Condensate Drain Connection**

- 2 - Make a water-tight connection between the field-provided condensate drain line and the flexible condensate connector. Use 1-1/2" OD / 1-1/4" ID PVC pipe for the drain line.  
 3 - See figure 9 for applications including a single unit and a single drain. In this case, ensure that the drain line is properly sloped (no less than 1/4 inch per foot) and condensate lines are routed to ensure moisture is drained away from the indoor unit.



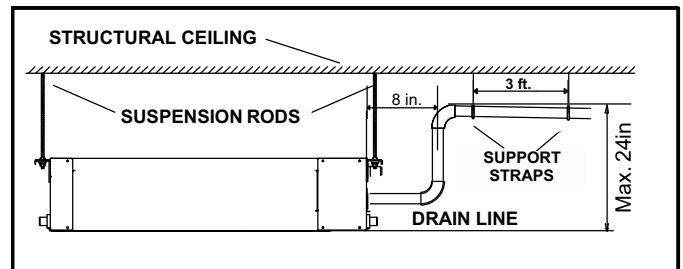
**Figure 9. Sloped Condensate Drain — Single Unit**

**IMPORTANT !**  
 Drain should have a slope of at least 1/4 inch per foot and should be approved corrosion-resistant pipe.



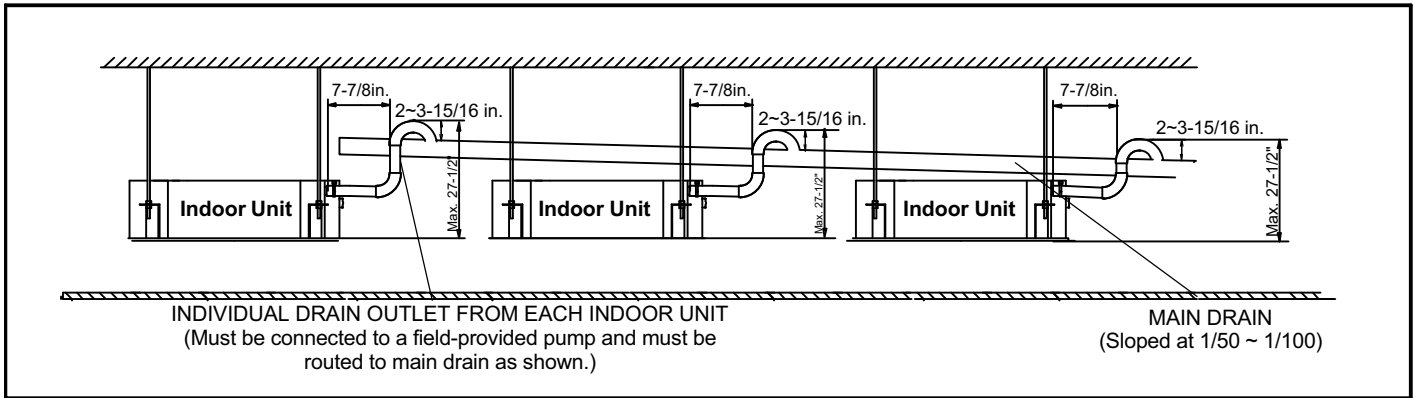
**Figure 10. Sloped Condensate Drain — Multiple Units**

- 4 - See figure 11 for applications including a single unit using the optional drain pump.  
**NOTE** - Drain pump kit (12A57) provides up to 30 inches of lift and is available for use with -024 through -054 units only.



**Figure 11. Condensate Drain with Pump — Single Unit**

- 5 - See figure 12 for applications including multiple units using the optional drain pump to provide lift into a single, correctly sized main drain. In this case, ensure that the main drain line is properly sloped (no less than 1/4 inch per foot) and that each individual drain is connected to the main drain exactly as shown.  
**NOTE** - Drain pump kit (12A57) provides up to 30 inches of lift and is available for use with -024 through -054 units only.  
 6 - In all cases, drain should be as short as possible and should not have any droops or kinks that would restrict condensate flow and shall be constructed using an approved pipe. **There must be a 2-inch space between the end of the condensate drain and the final termination point (ground, open drain, etc.) to ensure that the line will drain freely.**



**Figure 12. Using a Main Drain to Serve Multiple Indoor Units with Field-Provided Condensate Pumps**

7 - After system installation is complete, the condensate drain line must be checked for leaks and the condensate pumps (if used) must be checked to ensure proper operation. This check is part of the commissioning sequence. Funnel enough water to engage the pump (if used) into the drain pan through a flexible tube.

Refer to unit nameplate for minimum circuit ampacity and maximum overcurrent protection size.

**NOTE - Three-core shielded cable must be used for the communication wiring. This is necessary to ensure proper system communication and operation.**

**IMPORTANT !**

You must confirm operation of every drain and pump in the system as part of the commissioning procedure.

**Wiring Connections**

**⚠ WARNING**

Isolate the power supply before accessing unit electrical terminals.

Install unit so that unit disconnect is accessible.

Follow all local and national codes, as well as this installation instruction, during installation. Do NOT overload electrical circuit, as this may lead to failure and possible fire.

Use specified wiring and cable to make electrical connections. Clamp cables securely and make sure that connections are tight to avoid strain on wiring. Insecure wiring connections may result in equipment failure and risk of fire.

Wiring must be installed so that all cover plates can be securely closed.

Do not attempt to repair a damaged power cord.

Do not modify the power cord in any way. Do not attempt to extend the length of the power cord or use an extension cord with this appliance. Do not share the single power outlet with any other appliances.

In the U.S.A., wiring must conform with current local codes and the current National Electric Code (NEC). In Canada, wiring must conform with current local codes and the current Canadian Electrical Code (CEC).

**⚠ CAUTION**

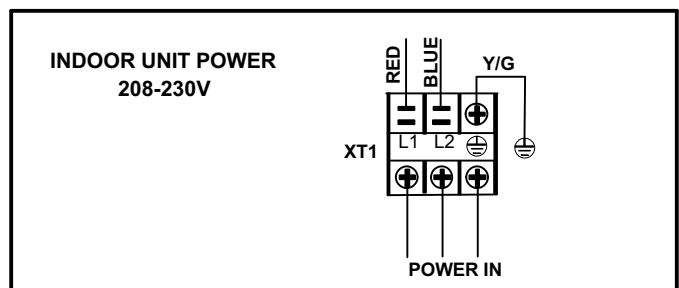
This unit must be properly grounded and protected by a circuit breaker. The ground wire for the unit must not be connected to a gas or water pipe, a lightning conductor or a telephone ground wire.

Do not connect power wires to the outdoor unit until all other wiring and piping connections have been completed.

Install all wiring at least 3 feet away from televisions, radios or other electronic devices in order to avoid the possibility of interference with the unit operation.

Do not install the unit near a lighting appliance that includes a ballast. The ballast may affect remote control operation.

- 1 - Remove the screws that secure the control box cover. Remove the cover and place it to the side where it will not be damaged.
- 2 - Locate the terminal strip in the control box. Connect the power wiring (sized per NEC/CEC and local codes) and communications cable (**three-core, shielded cable**) per figures 13 and 14. Refer to unit nameplate for rated voltage.



**Figure 13. Typical Power Wiring**

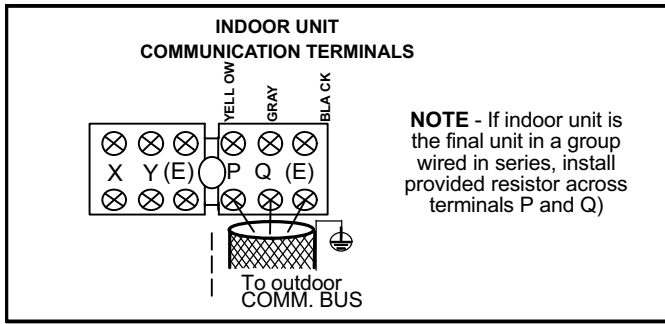


Figure 14. Typical Communications Wiring

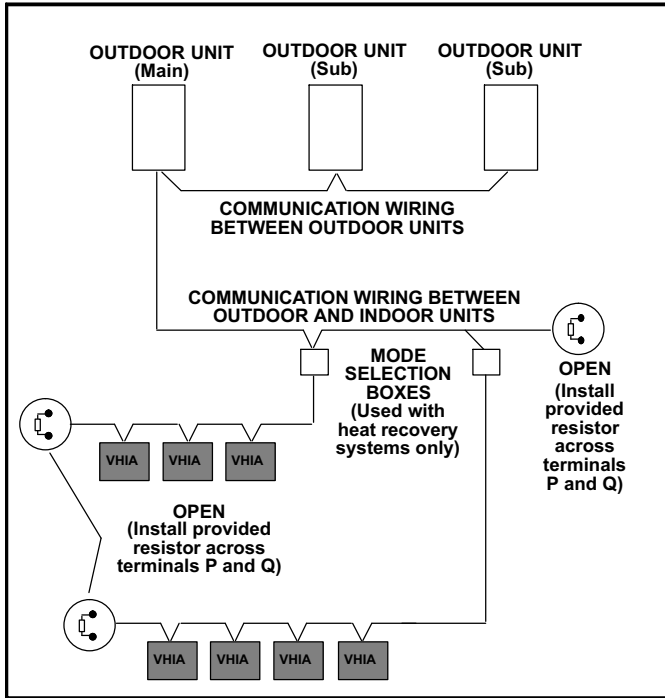


Figure 15. Typical Series Wiring of Indoor Units (with resistors)

- 3 - If the indoor unit is the final unit in a group that is wired in series, install the provided resistor across terminals P and Q. Refer to figure 15.
- 4 - The infra-red receiver / display panel is factory-installed and can be repositioned, if necessary. Use optional extension cable kit .

**IMPORTANT !**

**DO NOT adjust DIP switch settings. Settings may only be adjusted by a trained technician as part of the commissioning procedures.**

**Network Address and Commissioning**

After the system has been installed, each indoor unit must be assigned an address as part of the commissioning procedure.

