

NATURAL TO LP (PROPANE) GAS CHANGEOVER KIT

INSTALLATION INSTRUCTIONS FOR LP KIT (LB-107321L, M; 11U62, 11U63) USED ON LGH/KG/ZG 024-090 PACKAGED ROOFTOP UNITS

⚠ WARNING

This conversion kit shall be installed by a qualified service agency in accordance with the manufacturer's instructions and all applicable codes and requirements of the authority having jurisdiction. If the information in these instructions is not followed exactly, a fire, an explosion or production of carbon monoxide may result causing property damage, personal injury or loss of life. The qualified service agency is responsible for the proper installation of this kit. The installation is not proper and complete until the operation of the converted appliance is checked as specified in the manufacturer's instructions supplied with the kit.

Shipping and Packing List

11U62 Single-Stage Gas Valve

Package 1 of 1 contains:

- 7- Orifices
- 1- Spring kit
- 1- Bag assembly containing:
 - 1-Conversion plate
 - 1-Conversion sticker

11U63 Two-Stage Gas Valve

Package 1 of 1 contains:

- 7- Orifices
- 1- Spring kit
- 1- Bag assembly containing:
 - 1-Conversion plate
 - 1-Conversion sticker
 - 1-Acrylic sheet
 - 1-J/P21 harness
 - 1-Jumper wire
- 1- Bag assembly containing:
 - 1-Pressure switch
 - 1-Hex adapter
 - 1-Wire (discard)
 - 1-Spring kit (discard)

Requirements

This conversion kit shall be installed by a qualified service agency. A qualified service agency is any individual, firm, corporation or company which either in person or through a representative is engaged in and is responsible for the connection, installation, repair or servicing of gas utilization equipment or accessories, who is experienced in such work, familiar with all precautions required, and has complied with all the requirements of the authority having jurisdiction.

Canadian installations only - The conversion shall be carried out in accordance with the requirements of the Provincial authorities having jurisdiction and in accordance with the requirements of the CAN/CGA-B149.1 and .2 Installation Code.

Application

The LP/propane gas changeover kit is required for gas conversion on LGH/KG/ZG 024-090 units as follows:

- Single stage gas valve - 11U62 (LB-107321L)
- Two stage gas valve - 11U63 (LB-107321M)

See the unit nameplate to determine whether the unit has a single- or two-stage gas valve. An H, Q, U, or X in the 10th character of the model number indicates the unit is equipped with a two-stage gas valve. S, M, and T mean the unit contains a single-stage gas valve. For example, ZGA060S4BH1G would contain a two-stage gas valve.

Installation

⚠ WARNING

Improper installation, adjustment, alteration, service or maintenance can cause property damage, personal injury or loss of life. Installation and service must be performed by a qualified installer, service agency or the gas supplier

- 1- Turn main manual shut-off valve off and turn off electrical supply to unit. Set thermostat to "Off" position.
- 2- Open access panels as shown in figure 1. On LGH/KG units, remove the mullion between the heat and compressors sections.

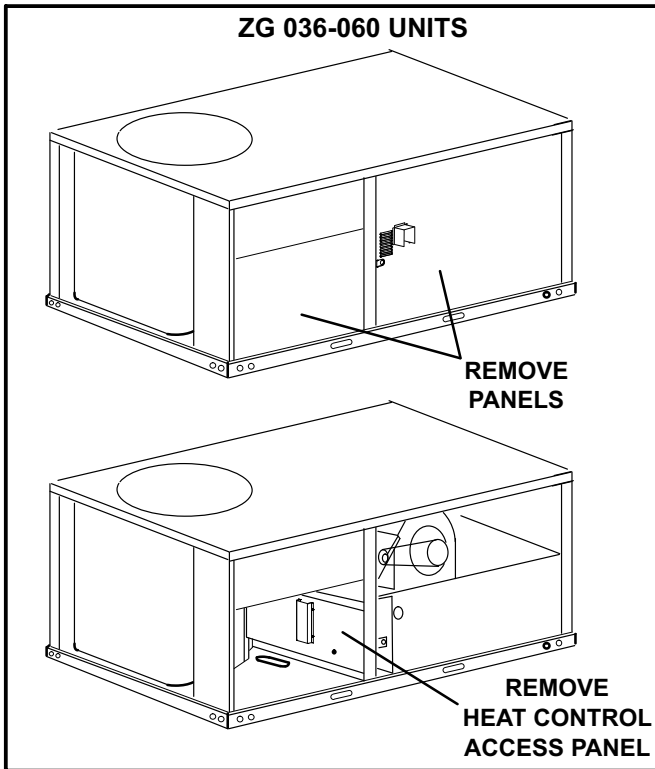

FIGURE 1

⚠ CAUTION

Danger of sharp metallic edges. Can cause injury. Take care when servicing unit to avoid accidental contact with sharp edges.

IMPORTANT-The gas supply shall be shut off prior to disconnecting the electrical power, before proceeding with this conversion.

- 3- Remove and retain four screws securing manifold to burner box; remove manifold. See figure 2 or 3.
- 4- Remove orifices from manifold and install the orifices provided in kit. Unit will have 3, 5, or 7 burners. Replace only the orifices which have a burner installed.

CAUTION - Tighten orifices with pipe threads to 6.25 ft.lbs. Do not overtighten.

IMPORTANT - Do not use thread compound on gas orifices.

- 5- Replace the manifold and secure with retained screws.
- 6- Install spring kit as shown in figure 4 for single-stage gas valves and figure 5 for two-stage gas valves. Also refer to the manufacturer's instructions provided with spring kit.

Note - When converting a two-stage gas valve, discard the spring kit and wire located in the bag assembly.

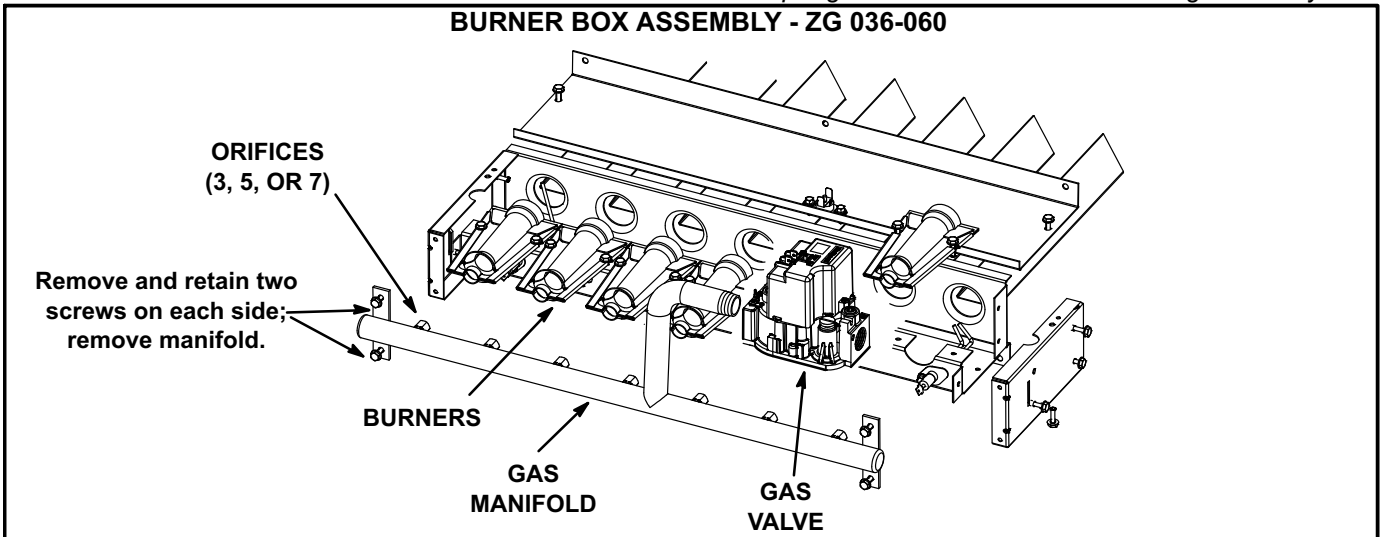

FIGURE 2

BURNER BOX ASSEMBLY - LGH/KG 024-090

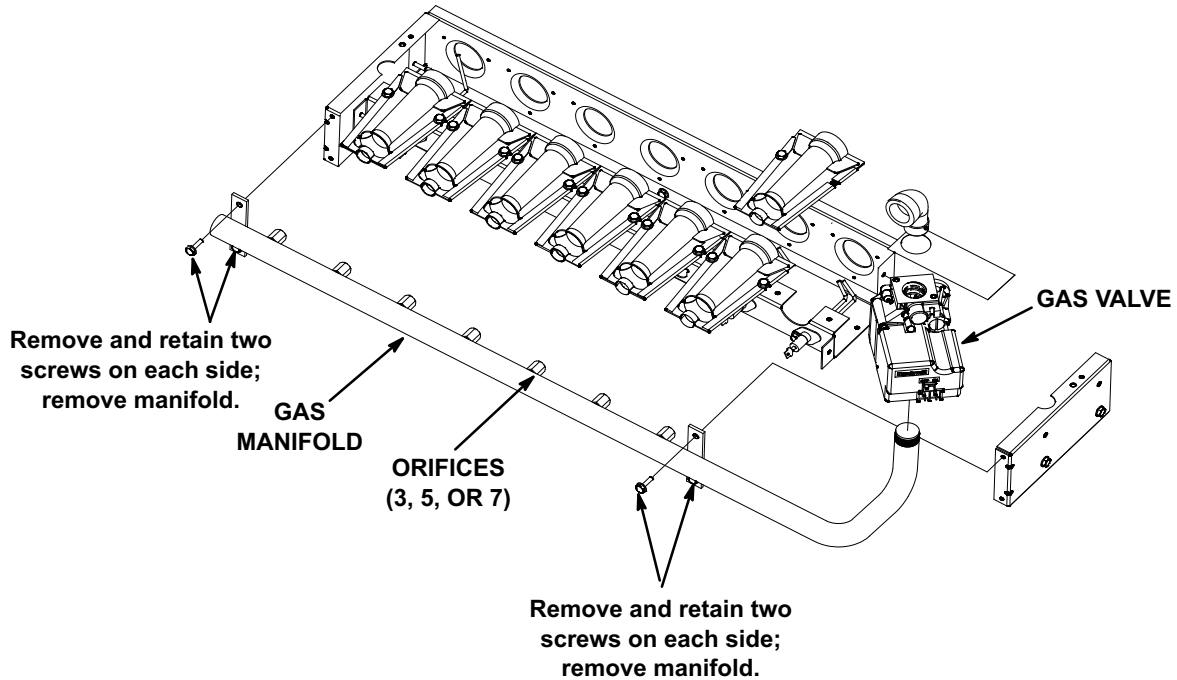

FIGURE 3

CONVERTING SINGLE-STAGE GAS VALVE (Natural to LP)

1. Remove regulator cap screw and pressure regulator adjusting screw.
2. Remove existing spring.
3. Insert replacement spring.
4. Install the new plastic pressure regulator adjustment screw so that the top of the screw is flush (level) with the top of the regulator. Turn the pressure regulator adjusting screw clockwise six complete turns. This adjustment provides a preliminary pressure setting of about 10.5" w.c. (2.6 kPa) for the LP regulator.
5. Check regulator setting either with a manometer or by clocking the gas meter.
6. Reinstall cap screw.

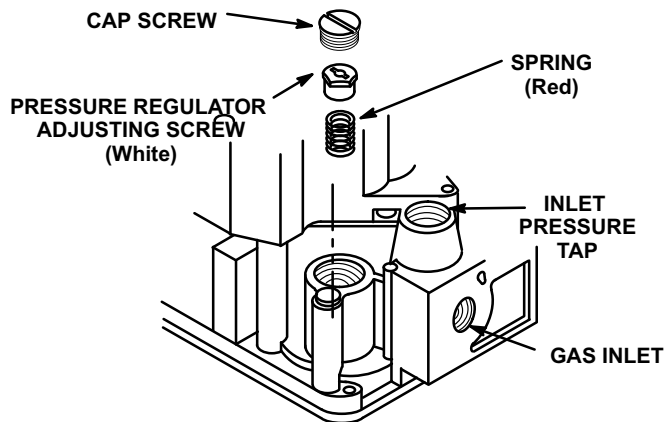

FIGURE 4

CONVERTING TWO-STAGE GAS VALVE (Natural to LP/Propane)

- 1- Remove both high fire and low fire springs from the gas valve.
- 2- Replace both high fire and low fire springs with the provided LP springs color-coded white.
- 3- Install the high fire adjustment screw and adjust approximately 12 turns.
- 4- Install the low fire adjustment screw and adjust approximately 8 turns.
- 5- Install both regulator screw covers.

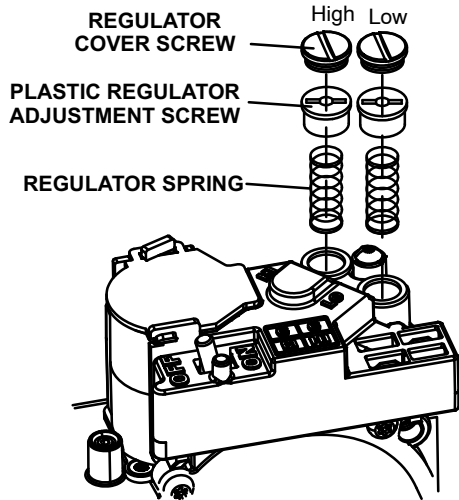

FIGURE 5

Pressure Switch - Two-Stage Gas Valves

- 1- Disconnect power and shut off gas supply to unit.
- 2- Install the hex adapter and pressure switch on the inlet pressure tap of the two-stage gas valve. Apply pipe sealer to at least the first three threads of hex adapter. See figure 6.

NOTE-Compounds used on threaded joints of gas piping must be resistant to the action of LP/propane gas.

PRESSURE SWITCH INSTALLATION ON TWO-STAGE VALVE

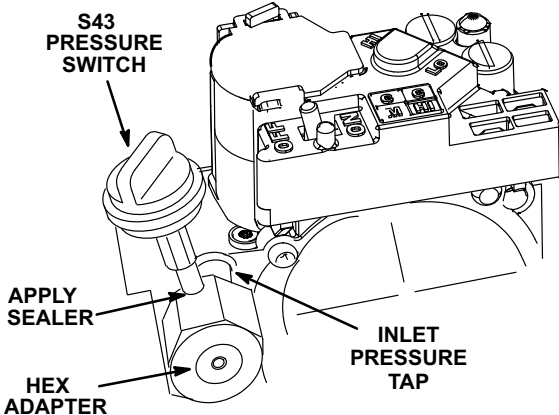

FIGURE 6

- 3- Locate J19/P19 combustion air blower connectors in divider panel between heat and compressor sections.
- 4- Disconnect J19/P19.
- 5- Install kit harness between disconnected plugs. See figure 7.

INSTALL JUMPER PLUG

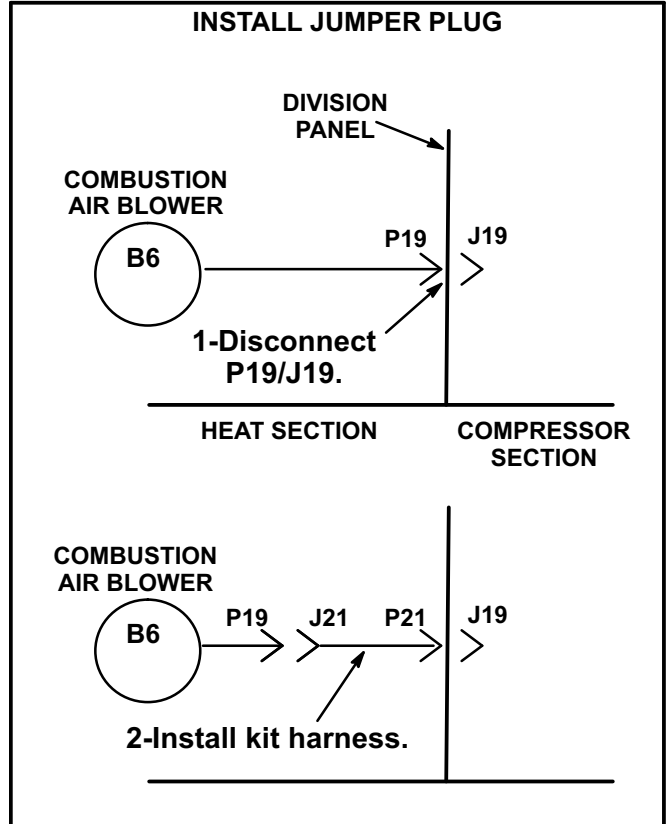

FIGURE 7

- 6- Locate S18 combustion air prove switch and disconnect wire labeled S18-S47 or P1-5-S18. See figure 8 or 9.
- 7- *ZG Units -*
Reattach wire marked S18-S47 to S43 LP low pressure switch on gas valve. See figure 8.
LGH/KG Units -
Pull wire labeled P1-5-S18 through division panel into the compressor section. Connect the wire to S43 LP low pressure switch on gas valve. See figure 9.
- 8- *ZG Units -*
Connect the jumper wire provided in this kit to S43 pressure switch and S18 combustion air prove switch. See Figure 8.
LGH/KG Units -
Connect the jumper wire provided in this kit to S43 pressure switch and route through division panel to heat section. Connect to S18 combustion air prove switch. See Figure 9.

INSTALL JUMPER WIRE (TWO-STAGE GAS VALVES) - ZG 036-060 UNITS

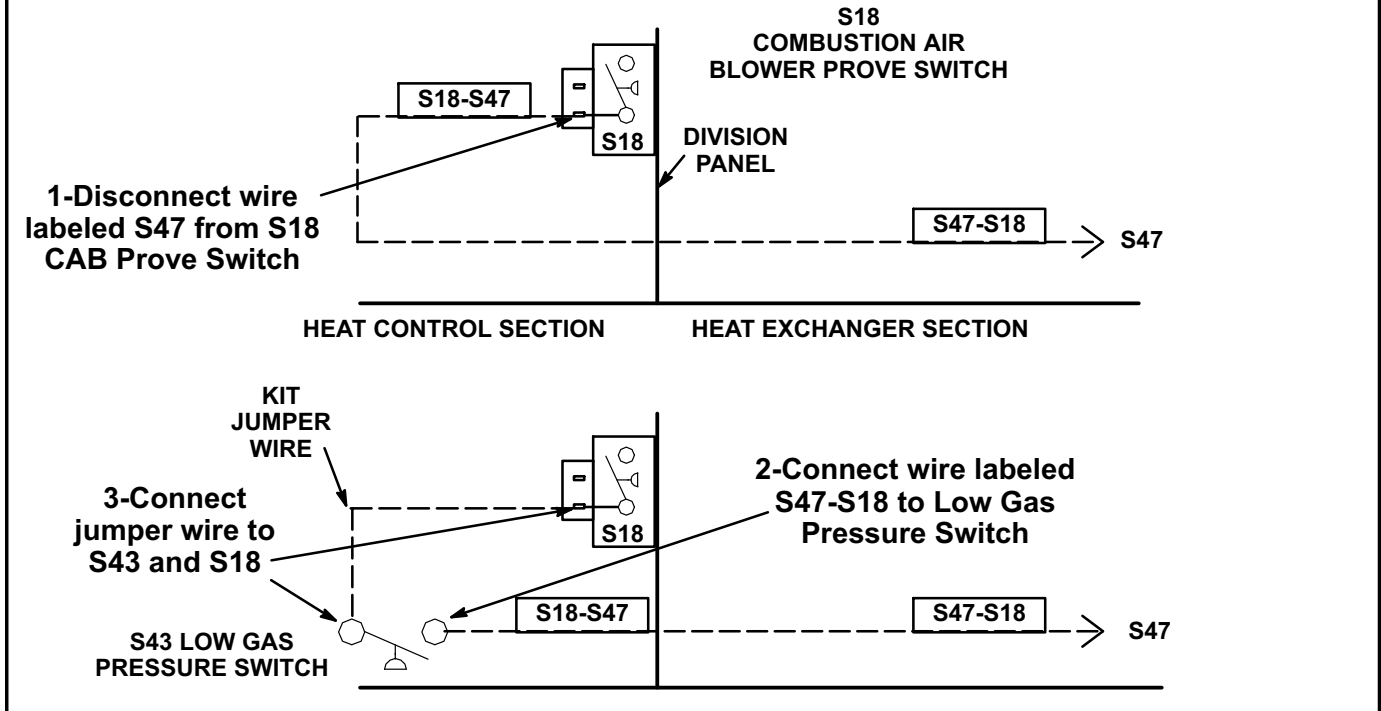

FIGURE 8

INSTALL JUMPER WIRE - LGH/KG 024-090

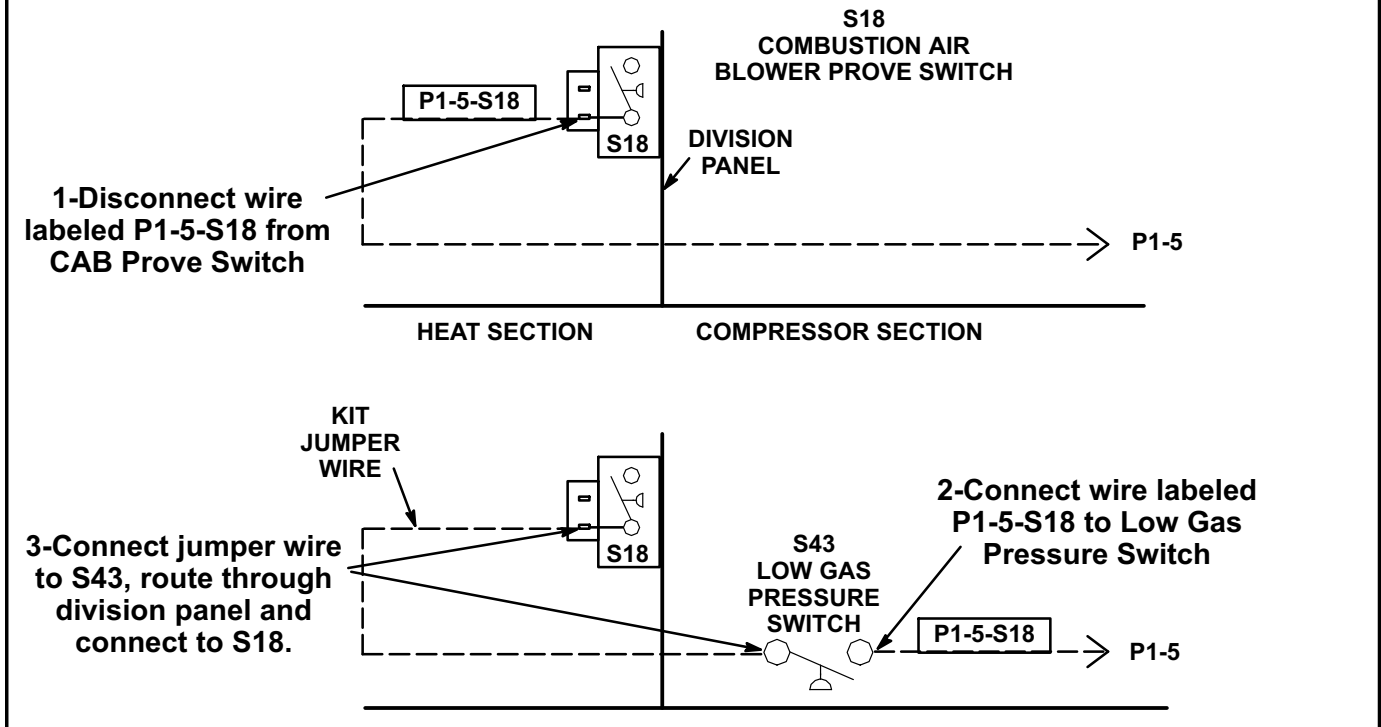

FIGURE 9

Start-Up And Adjustments

- 1- Replace heat section access panels and mullion.
- 2- Close heat section access panel.

A-To place unit in operation:

- 1- Turn main manual shut-off valve on.

WARNING



Danger of explosion. Can cause injury or death. Do not attempt to light manually. Unit has a direct spark ignition system.

- 2- Wait five minutes, then open manual knob on gas valve and replace compressor access panel.
- 3- Restore electrical supply to unit and set fan switch to "Auto" or "On." Move system selection switch to "Heat" and adjust thermostat setting above room temperature.
- 4- The combustion air blower will start and burners will light within 40 seconds.
- 5- If burners do not light first time (gas line not fully purged), ignition system will attempt to light two more times before locking out gas valve operation.
- 6- If lockout occurs, repeat steps 1, 2 and 3 above.

B-To shut down unit operation:

- 1- Set thermostat selection switch to "Off" position, remove heat control access panel and turn manual knob on gas valve to "Off" position.
- 2- Replace heat control access panel.

C-Heating Adjustment

Check gas line pressure with unit firing at maximum rate. A minimum of 10.8" w.c., and a maximum of 13.5" w.c. should be maintained. Manifold pressure is preset at :

- 10.5" w.c. for single-stage gas valves
- 10.5" w.c. for two-stage gas valves at high fire
- 5.9" w.c. for two-stage gas valves at low fire

No adjustment should be necessary. On multiple unit installations, each unit should be checked in sequence beginning with the one closest to the supply gas main and progressing to the one furthest from the main.

Identifying Unit As LP Converted

- 1- Make a check mark in the appropriate box on the conversion plate corresponding to unit model number shown on nameplate. Affix appropriate conversion plate near unit nameplate.
- 2- Complete installer information on converter sticker and affix to vestibule panel. Affix acrylic sheet over converter sticker.