



©2015 Lennox Industries Inc.
Dallas, Texas, USA

HEAT PUMP COIL REPLACEMENT KIT

INSTALLATION INSTRUCTIONS FOR ALUMINUM COIL REPLACEMENT KITS USED WITH SL18XP1 HEAT PUMPS (12X11, 12X13, 12X14)

Shipping and Packing List

Package 1 of 1 contains:

- 1 - Coil assembly
- 1 - Bag assembly
 - 1- Installation Instruction
 - 1- 1/2" coupling
 - 1- TXV Teflon washer

Check the replacement coil for shipping damage. If you find any damage, immediately contact the last carrier.

⚠ WARNING

Improper installation, adjustment, alteration, service or maintenance can cause personal injury, loss of life, or damage to property.

Installation and service must be performed by a licensed professional installer (or equivalent) or a service agency.

⚠ CAUTION

As with any mechanical equipment, contact with sharp sheet metal edges can result in personal injury. Take care while handling this equipment and use protective clothing.

⚠ WARNING

To prevent personal injury, as well as damage to panels, unit or structure, observe the following:

While installing or servicing this unit, carefully stow all removed panels so that the panels will not cause injury to personnel, objects or nearby structures. Also, take care to store panels where they will not be subject to damage (e.g., being bent or scratched).

While handling or stowing the panels, consider any weather conditions (especially wind) that may cause panels to be blown around and damaged.

⚠ WARNING



Electric Shock Hazard. Can cause injury or death. Unit must be grounded in accordance with national and local codes.

Line voltage is present at all components when unit is not in operation on units with single-pole contactors. Disconnect all remote electric power supplies before opening access panel. Unit may have multiple power supplies.

Requirements

Verify that the new coil has holding charge. Remove the cap from the discharge line and press the valve core. The coil should have approximately 10 psi dry air holding charge. If there is no charge, repressurize the coil and check for leaks.

Verify that the liquid and discharge manifold position matches that of the existing coil before removing original coil. Take care not to damage the liquid line stub.



FIGURE 1. Aluminum Replacement Coil

Applicable Units

This installation instruction is used with the following heat pump manifold-style replacement coils:

Applicable Units	Lennox Catalog Number	Lennox Part Number
SL18XP1-024 / -030	12X11	614155-01
SL18XP1-036 / -042	12X13	614155-02
SL18XP1-048 / -060	12X14	614155-03

Installation

⚠ CAUTION

Before attempting to perform any service or maintenance, turn the electrical power to unit OFF at disconnect switch.

⚠ IMPORTANT

The stub of the coil must be secured if any adjustments to the liquid line are needed. Do not allow it to move.

1. Disconnect all power to the unit.
2. Reclaim the refrigerant from the unit.
3. Remove access panel, side (louvered) panels, top panel, and corner posts. Remove the screws that attach the coil endplate to the control box and compressor enclosure. Keep the screws.
4. Disconnect the Chatleff-style threaded connection between the coil distributor and outdoor expansion valve. Take care to preserve as much of the factory lubricant used on this joint as possible.

NOTE - This lubricant (Loctite 8009 heavy-duty anti-seize lubricant) is used to help prevent the male aluminum distributor threads and brass female nut threads from wearing due to friction between the sliding surfaces.

5. Remove the TXV sensing bulb from the vapor line. Unbraid the joint in the copper vapor line between the TXV equalizer line fitting and the vapor copper/aluminum joint. Refer to Figure 2 for joint location.
6. Remove the existing coil.
7. Install the replacement coil assembly.
8. Remove the holding charge by pressing the valve core.

⚠ IMPORTANT

Apply a wet cloth to the factory copper-to-aluminum joints and the pressure switch to prevent heat damage when brazing in the field copper-to-copper joints for the replacement coil. See figure 3.

9. Remove the Chatleff fitting stub from the replacement coil distributor. Reconnect the TXV Chatleff fitting to the new coil distributor using the provided Teflon washer. Include as much of the original factory lubricant on the threads as possible when making the connection.
10. Replace the screws that attach the coil endplate to the control box and compressor enclosure.
11. Replace the corner posts, side (louvered) panels and top panel.
12. Refer to the unit installation instructions for leak testing, evacuation and start-up procedures. Charge the unit as outlined in the installation instructions or according to the charging sticker.
13. Once installation of the replacement coil is complete, confirm that all refrigerant tubing and wiring is properly routed away from other wiring and sharp metal edges.
14. Start the compressor and observe the discharge line. Verify that there is minimal vibration between the shock loop and the manifold on the outdoor coil's discharge line.
15. If there is visible motion, apply weight kit (catalog number 38K46) to the discharge line. Install the weight kit on the horizontal run after the shock loop or other suitable area to achieve acceptable results. Rotate the weight kit on the tubing to change vibration characteristics.
NOTE - Visible motion could result in a future failure of the replacement coil.
16. Replace access panel.

IMPORTANT

OBSERVE THE FOLLOWING PRECAUTIONS TO PREVENT DAMAGE TO ALUMINUM SOLDER JOINTS OR THREADED CONNECTIONS WHEN REPLACING AN ALUMINUM OUTDOOR COIL

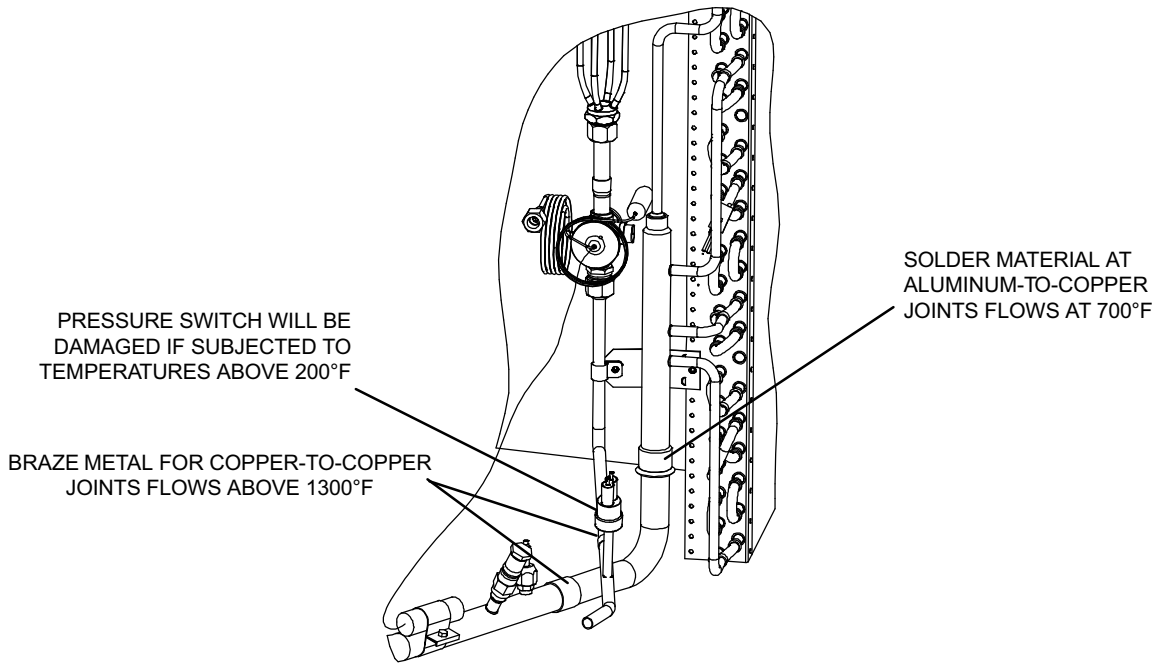

TO PREVENT DAMAGE TO ALUMINUM JOINTS, WET RAGS AND / OR THERMAL TRAP PASTE MUST BE APPLIED TO THE AREAS HIGHLIGHTED BELOW BEFORE BRAZING. WET RAGS MUST BE LEFT ON PROTECTED AREAS UNTIL BRAZED JOINTS HAVE COOLED DOWN TO AMBIENT TEMPERATURE TO PREVENT MIGRATION OF HEAT INTO THE ALUMINUM SOLDERED JOINTS OR PRESSURE SWITCH.

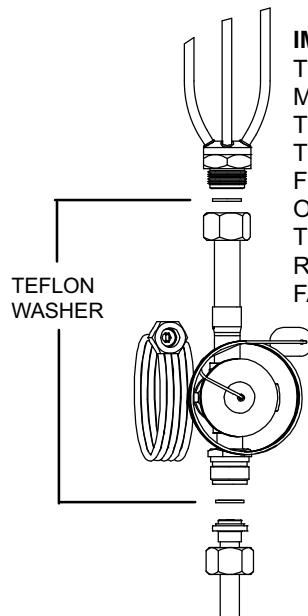
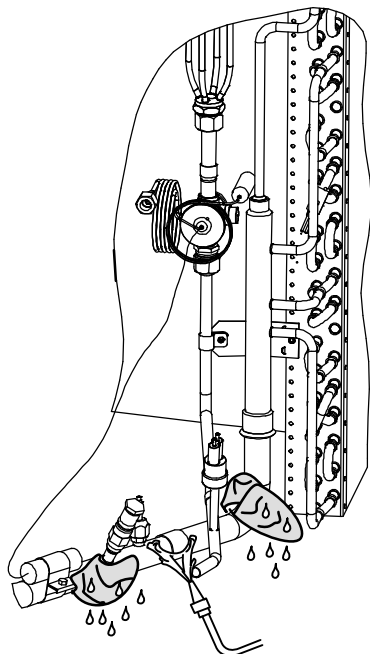

IMPORTANT: WHEN MAKING THE THREADED CONNECTION BETWEEN THE MALE THREADS OF THE ALUMINUM DISTRIBUTOR AND THE BRASS THREADS OF THE FEMALE NUT ON THE CHATLEFF TXV FITTING, INCLUDE AS MUCH OF THE ORIGINAL FACTORY LUBRICANT ON THE THREADS AS POSSIBLE. THIS LUBRICANT REDUCES WEAR ON THE THREAD SURFACES.

FIGURE 2. Important Precautions for Coil Installation