

BLOWER SPEED CHART

UNIT (INPUT-CFM)	FACTORY CONNECTED SPEED TAPS			MOTOR SPEEDS AVAIL.
	COOL	HEAT	PARK	
045-08		YELLOW	BLACK, RED	4
045-12		RED	BLACK, YELLOW	4
070-08	BROWN	BLACK	YELLOW, RED	4
070-12		YELLOW	BLACK, RED	4
090-12		YELLOW	BLACK, RED	4
090-16		YELLOW	BLACK, RED	4
110-16		BLACK	YELLOW, RED	4
110-20		YELLOW	BLACK, RED	4
135-20		YELLOW	BLACK, RED	4

BLOWER SPEED SELECTION: HI ← → LO

SPEED TAPS	BLACK	BROWN	YELLOW	RED	4
------------	-------	-------	--------	-----	---

THERMOSTAT HEAT ANTICIPATION SETTINGS

.65 AMP	HONEYWELL VALVE
.50 AMP	WHITE-RODGERS VALVE

JACKPLUG CHART

J,P58	JACK/PLUG-BURNER CONTROL
J,P156	JACK/PLUG-INDUCER/IGNITER
J,P159	JACK/PLUG-IGNITER

WARNING-
ELECTRIC SHOCK HAZARD, CAN CAUSE INJURY OR DEATH. UNIT MUST BE GROUNDED IN ACCORDANCE WITH NATIONAL AND LOCAL CODES

NOTE-
IF ANY WIRE IN THIS APPLIANCE IS REPLACED, IT MUST BE REPLACED WITH WIRE OF LIKE SIZE, RATING, INSULATION THICKNESS AND TERMINATION

IMPORTANT-
TO PREVENT MOTOR BURNOUT, NEVER CONNECT MORE THAN ONE LEAD TO ANY ONE CONNECTION

2 PARK TERMINALS ARE UNPOWERED TERMINALS. ALL UNUSED MOTOR LEADS MUST BE WIRED TO A PARK TERMINAL

3 FIELD SUPPLIED ACC. WIRE

4 DO NOT USE RED (LOW SPD) MOTOR LEAD FOR HEATING. LEAVE ON PARK TERMINAL FOR 070B08, 070BP08, 090C12, 090CP12, 110C16, 110CP16, 135D20, AND 135DP20

5 S145 IS USED WITH HONEYWELL GAS VALVE WHEN APPLIED IN LP GAS UNITS

6 HEAT/COOL JUMPER PRESENT ON SOME MODELS

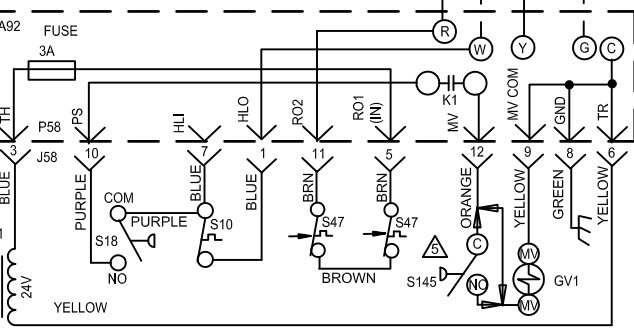
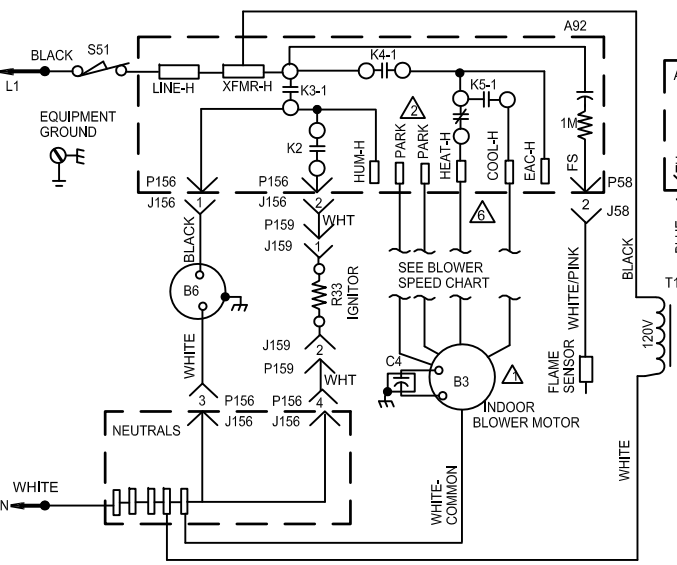
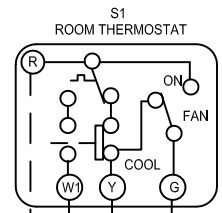

— DENOTES OPTIONAL COMPONENTS
 — LINE VOLTAGE FIELD INSTALLED
 — CLASS II VOLTAGE FIELD WIRING

HEATING UNITS-GAS

0512 Supersedes

Form No. 537344-01