

BLOWER SPEED CHART			
UNIT (INPUT-CFM)	FACTORY CONNECTED SPEED TAPS	MOTOR SPEEDS AVAILABLE	
045-12	BROWN HEAT PARK	BLACK/RED	4
070-12	BLACK BROWN YELLOW/RED	YELLOW/RED	4
090-20	BLACK BROWN YELLOW/RED	YELLOW/RED	4
110-20	BLACK YELLOW BROWN/RED	BROWN/RED	4
BLOWER SPEED SELECTION			
HI		LO	
SPEED TAPS	BLACK BROWN YELLOW RED		4

THERMOSTAT HEAT ANTICIPATION SETTINGS

.85 AMP	HONEYWELL VALVE
.50 AMP	WHITE-RODGERS VALVE
J1P58	JACKPLUG-BURNER CONTROL
J1P156	JACKPLUG-INDUCER/IGNITER
J1P159	JACKPLUG-IGNITER

WARNING-
ELECTRIC SHOCK HAZARD. CAN CAUSE INJURY OR DEATH. UNIT MUST BE GROUNDED IN ACCORDANCE WITH NATIONAL AND LOCAL CODES

NOTE-
IF ANY WIRE IN THIS APPLIANCE IS REPLACED, IT MUST BE REPLACED WITH WIRE OF LINE SIZE, RATING, INSULATION THICKNESS AND TERMINATION

IMPORTANT-
TO PREVENT MOTOR BURNOUT, NEVER CONNECT MORE THAN ONE LEAD TO ANY ONE CONNECTION. PARK TERMINALS ARE UNPOWERED TERMINALS. ALL UNUSED MOTOR LEADS MUST BE WIRED TO A PARK TERMINAL

FIELD SUPPLIED ACC. WIRE
S145 IS USED WITH HONEYWELL GAS VALVE WHEN APPLIED IN LP GAS UNITS

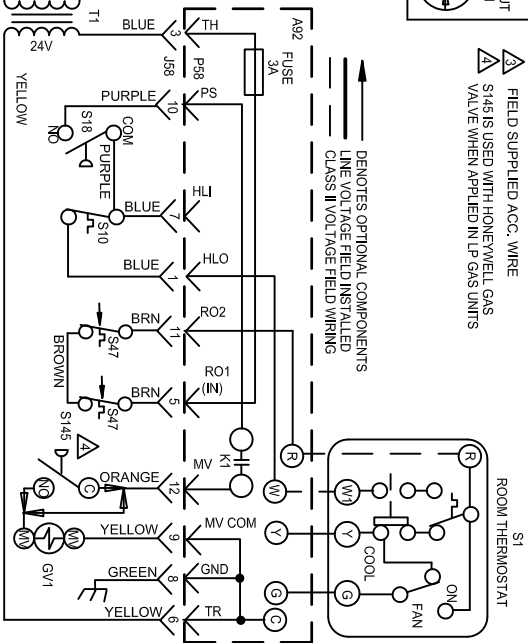
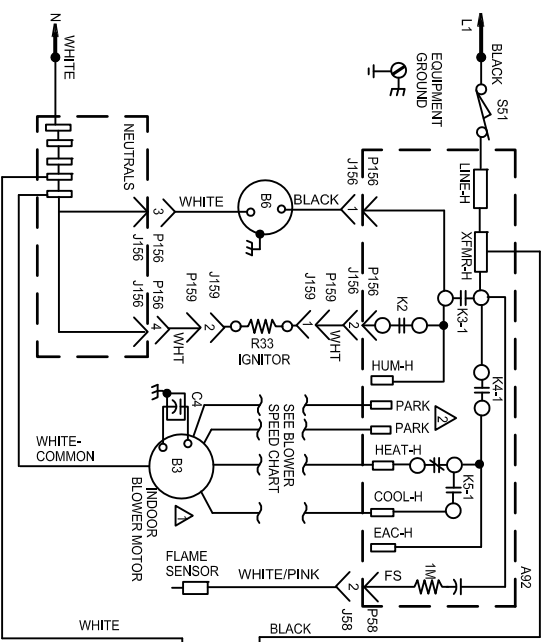

DENOTES OPTIONAL COMPONENTS
LINE VOLTAGE FIELD INSTALLED
CLASS II VOLTAGE FIELD WIRING

HEATING UNITS-GAS

0512	Supersedes
0512	



Form No.
537435-01