

BLOWER SPEED CHART

UNIT (INPUT-CFM)	FACTORY CONNECTED SPEED TAPS	MOTOR SPEEDS AVAILABLE
045-12	BROWN HEAT PARK	BLACK/RED 4
070-12	BROWN HEAT PARK	BROWN YELLOW/RED 4
090-20	BLACK BROWN YELLOW/RED	BLACK BROWN/RED 4
110-20	BLACK YELLOW BROWN/RED	BLACK YELLOW 4

HI ← BLOWER SPEED SELECTION → LO

SPEED TAPS: BLACK BROWN YELLOW RED 4

THERMOSTAT HEAT ANTICIPATION SETTINGS

.85 AMP	HONEYWELL VALVE
.50 AMP	WHITE-RODGERS VALVE

JACKPLUG CHART

J1P58	JACKPLUG-BURNER CONTROL
J1P56	JACKPLUG-INDUCER/IGNITER
J1P159	JACKPLUG-IGNITER

WARNING- ELECTRICAL SHOCK HAZARD. CAN CAUSE INJURY OR DEATH. UNIT MUST BE GROUNDED IN ACCORDANCE WITH NATIONAL AND LOCAL CODES

NOTE- IF ANY WIRE IN THIS APPLIANCE IS REPLACED, IT MUST BE REPLACED WITH WIRE OF LINE SIZE, RATING, INSULATION THICKNESS AND TERMINATION

IMPORTANT- TO PREVENT MOTOR BURNOUT, NEVER CONNECT MORE THAN ONE LEAD TO ANY ONE CONNECTION. PARK TERMINALS ARE UNPOWERED TERMINALS. ALL UNUSED MOTOR LEADS MUST BE WIRED TO A PARK TERMINAL

FIELD SUPPLIED ACC. WIRE
S145 IS USED WITH HONEYWELL GAS VALVE WHEN APPLIED IN LP GAS UNITS

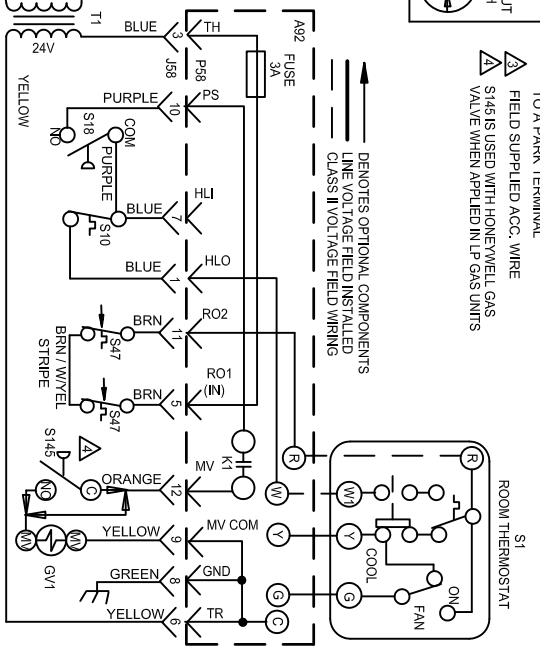
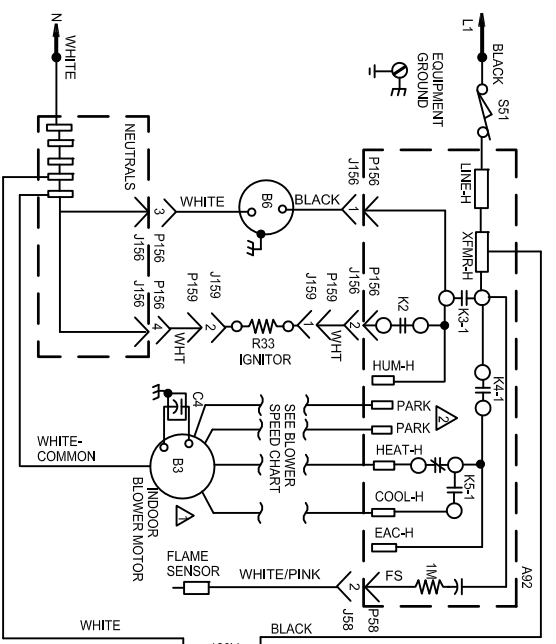

— DENOTES OPTIONAL COMPONENTS
— LINE VOLTAGE FIELD INSTALLED
— CLASS II VOLTAGE FIELD WIRING

HEATING UNITS-GAS

Supersedes

Form No. 537435-01

1214

© 2011