

KEY	DESCRIPTION
A55	CONTROL, BOARD LENNOX
CB10	CIRCUIT BREAKER, MAIN DISCONNECT
F3	FUSE, ELECTRIC HEAT
F4	FUSE, UNIT
F42	FUSE, ELECTRIC HEAT 1 A, 2A
F43	FUSE, ELECTRIC HEAT 3, 4
F44	FUSE, ELECTRIC HEAT 5
F45	FUSE, ELECTRIC HEAT 6, 7
HE1	ELEMENT, ELECTRIC HEAT 1
HE2	ELEMENT, ELECTRIC HEAT 2
HE3	ELEMENT, ELECTRIC HEAT 3
HE4	ELEMENT, ELECTRIC HEAT 4
HE5	ELEMENT, ELECTRIC HEAT 5
HE7	ELEMENT, ELECTRIC HEAT 7
HE8	ELEMENT, ELECTRIC HEAT 8
K9-1	RELAY, HEAT
K15-1	CONTACTOR, ELECTRIC HEAT 1,2
K16-1	CONTACTOR, ELECTRIC HEAT 1A,2A
K17-1	CONTACTOR, ELECTRIC HEAT 3,4

J/P	JACK/PLUG DESCRIPTION
7	ELECTRIC HEAT SUB-BASE KIT
37	ELECTRIC HEAT LIMIT
265	CONTACTOR RELAY
266	HEATING CONTROL
271	HEATING SENSORS STG 1
272	HEATING SENSORS STG 2

K18-1	CONTACTOR, ELECTRIC HEAT 5
S15	SWITCH, LIMIT PRIMARY ELECTRIC HEAT
S20	SWITCH, LIMIT SECONDARY ELECTRIC HEAT 1
S107	SWITCH, PRIMARY ELECTRIC HEAT
S157	SWITCH, LIMIT SECONDARY ELECTRIC HEAT 1A
S158	SWITCH, LIMIT SECONDARY ELECTRIC HEAT 2A
S159	SWITCH, LIMIT SECONDARY ELECTRIC HEAT 3,4
S160	SWITCH, LIMIT SECONDARY ELECTRIC HEAT 5,6
TB3	TERMINAL STRIP, ELECTRIC HEAT

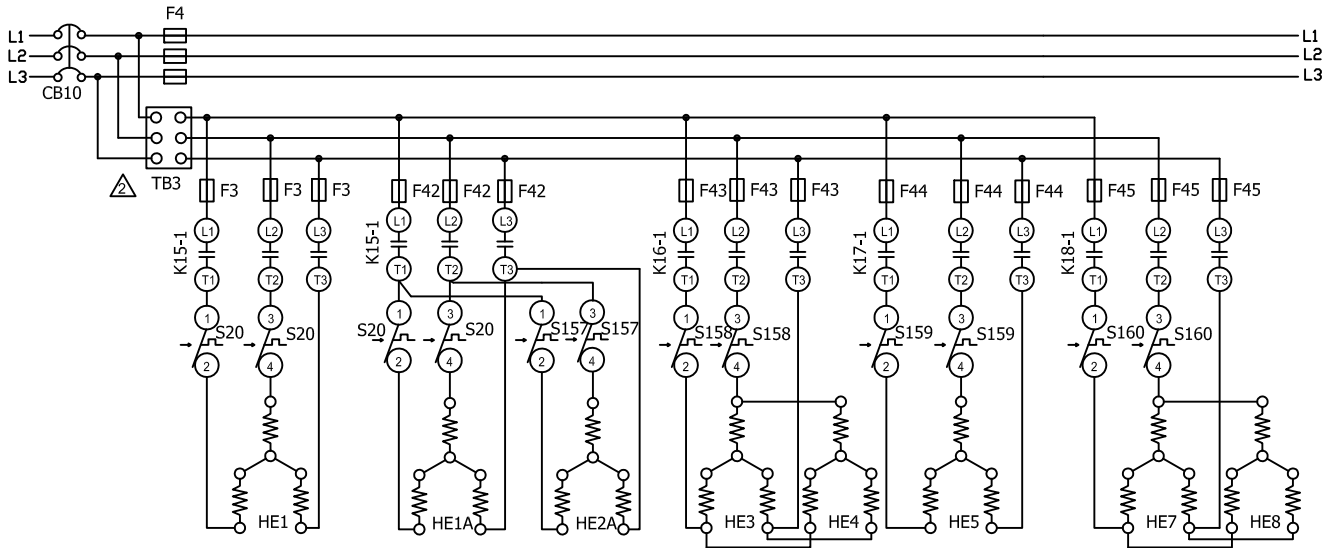

⚠ NOT USED ON 20 AND 30KW UNITS

⚠ TB3 IS USED IN SOME UNITS

← DENOTES OPTIONAL COMPONENTS

KW	HE1	H1A	H2A	HE3	HE4	HE5	HE7	HE8
20		10	10					
30		15	15					
40		20	20					
60	15			15		15	15	
80	20			20		20	20	
90	15			15	15	15	15	15

DESIGNATION	VOLTAGE
G	460/60/3
J	575/60/3

01/12	 STRATEGOS WIRING DIAGRAM 537504-01	01/12
HEATING		
ELECTRIC HEAT FOR STRATEGOS™ EHA - 20,30,40,60,90 - G,J		
SECTION A		
Supersedes	New Form No. 537504-01	