

KEY	DESCRIPTION	COMPONENT
CB1	CIRCUIT BREAKER-ELECT HEAT	
CB2	CIRCUIT BREAKER-ELECT HEAT	
HE1	ELEMENT-ELECTRIC HEAT 1	
HE2	ELEMENT-ELECTRIC HEAT 2	
HE3	ELEMENT-ELECTRIC HEAT 3	
HE4	ELEMENT-ELECTRIC HEAT 4	
K32-1/2	RELAY-ELECTRIC HEAT	
K33-1/2	RELAY-ELECTRIC HEAT	
K34-1/2	RELAY-ELECTRIC HEAT	
K35-1/2	RELAY-ELECTRIC HEAT	
S15	SWITCH-LIMIT-PRIMARY-ELECT HEAT	
S20	SWITCH-LIMIT-SECONDARY-ELECT HEAT	

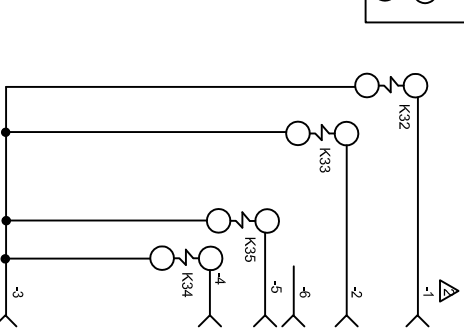

NOTE: USE COPPER CONDUCTORS ONLY.

CONNECT WIRES TO 1 THRU 9 TO P9 (9 PIN CONNECTOR) ON AHC CONTROL

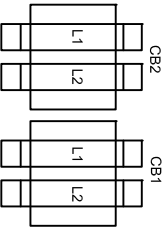
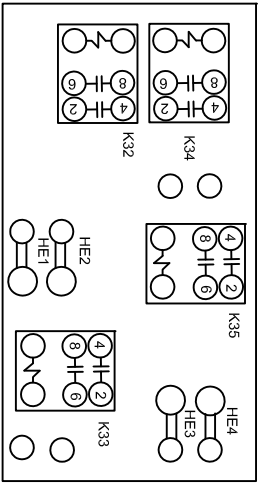
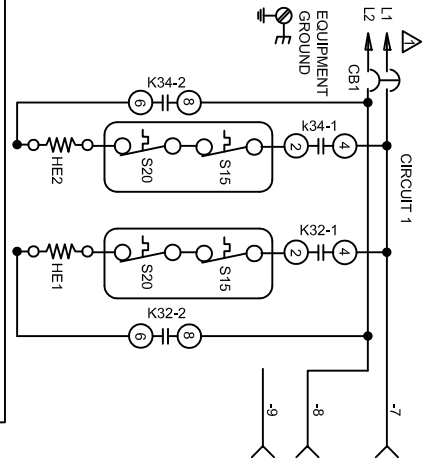
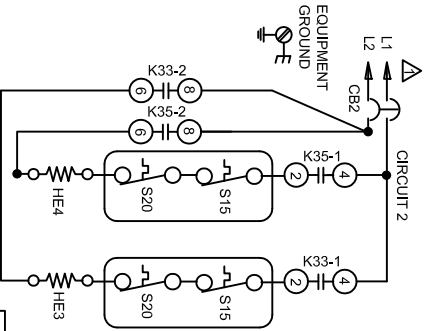

KEY	DESCRIPTION	COMPONENT
CB1	CIRCUIT BREAKER-ELECT HEAT	
CB2	CIRCUIT BREAKER-ELECT HEAT	
HE1	ELEMENT-ELECTRIC HEAT 1	
HE2	ELEMENT-ELECTRIC HEAT 2	
HE3	ELEMENT-ELECTRIC HEAT 3	
HE4	ELEMENT-ELECTRIC HEAT 4	
K32-1/2	RELAY-ELECTRIC HEAT	
K33-1/2	RELAY-ELECTRIC HEAT	
K34-1/2	RELAY-ELECTRIC HEAT	
K35-1/2	RELAY-ELECTRIC HEAT	
S15	SWITCH-LIMIT-PRIMARY-ELECT HEAT	
S20	SWITCH-LIMIT-SECONDARY-ELECT HEAT	

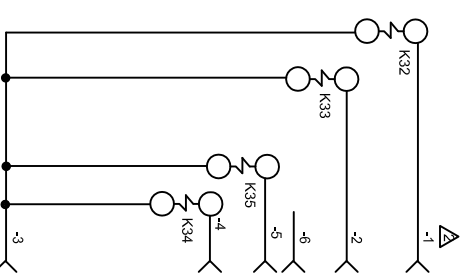

NOTE: USE COPPER CONDUCTORS ONLY.

CONNECT WIRES TO 1 THRU 9 TO P9 (9 PIN CONNECTOR) ON AHC CONTROL

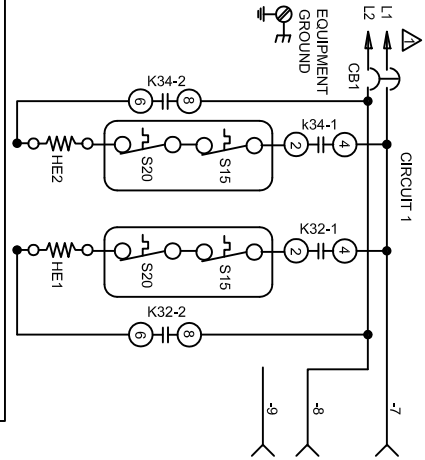
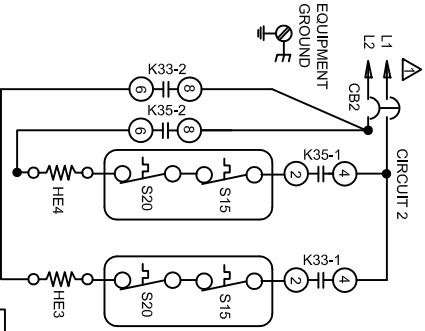

LENNIX HEATING-ELECTRIC

ECB40-20CB-P

Supersedes

0714



Form No.
537766-01

© 2008

Litho U.S.A.

LENNIX HEATING-ELECTRIC

ECB40-20CB-P

Supersedes

0714



Form No.
537766-01

© 2008

Litho U.S.A.