

ZG/ZC/ZH 036, 048, 060, 072 FORK TRUCK HANDLING INSTRUCTIONS

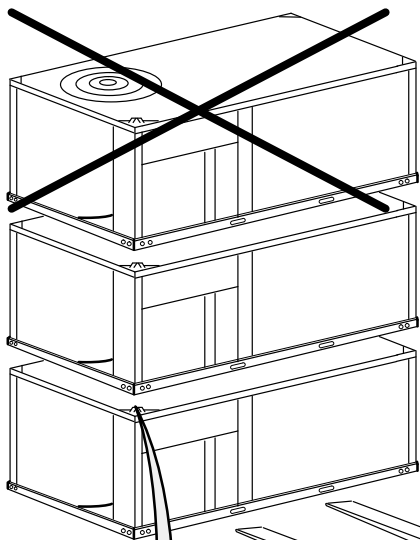

Only forks OVER 57", carry a maximum of 2 units.

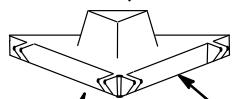
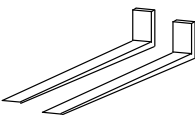

All four (4) brackets must be in place to stack multiple units or handle units.

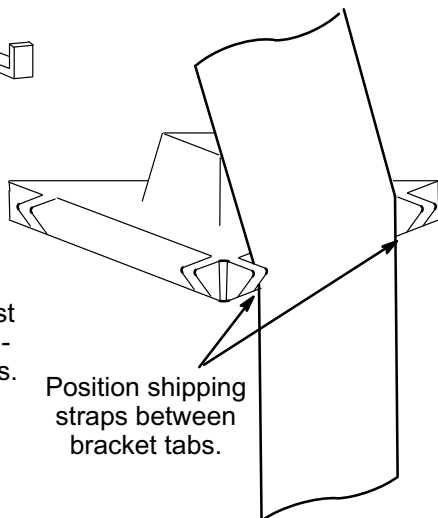

Position shipping straps between bracket tabs.

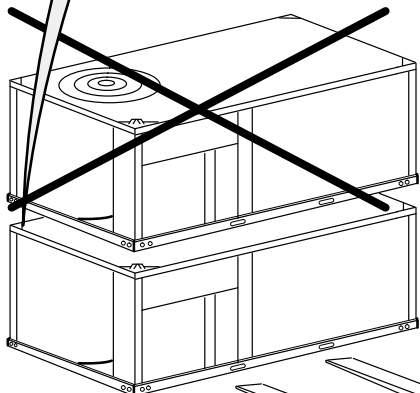

Forks 57" or SHORTER, carry a maximum of 1 unit.

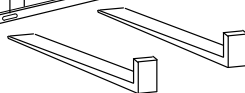

WARNING

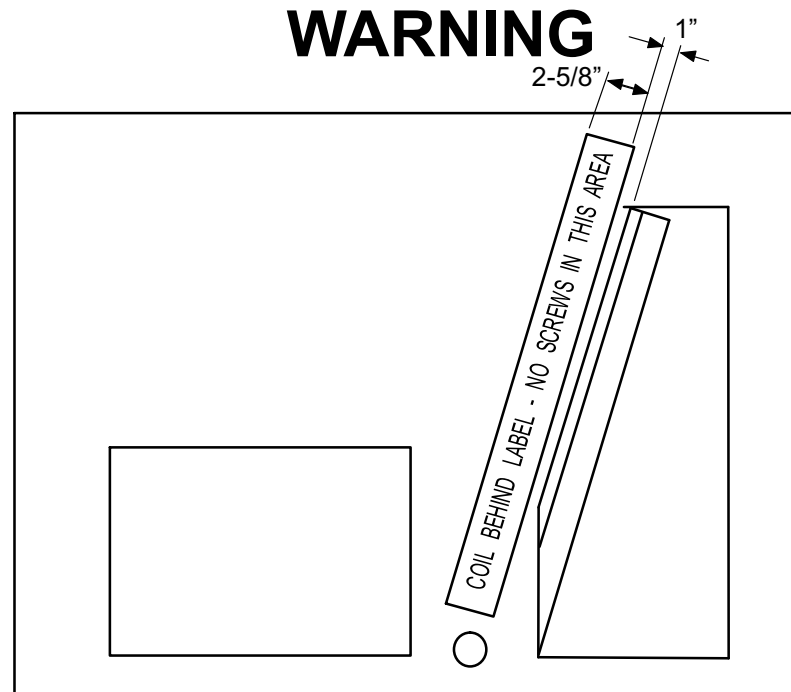

ZG/ZC/ZH 036, 048, 060, 072 RIGGING INSTRUCTIONS

- 1- Connect rigging to the unit base using both holes in each corner.
- 2- All panels must be in place for rigging.
- 3- Place field-provided H-style pick in place just above top edge of unit. Frame must be of adequate strength and length. (H-style pick prevents damage to top of unit.)

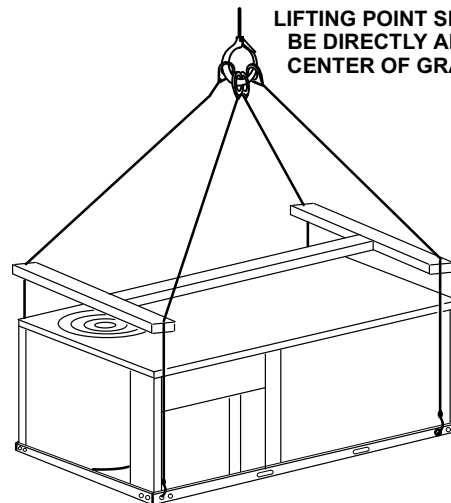

LIFTING POINT SHOULD BE DIRECTLY ABOVE CENTER OF GRAVITY

CAUTION - Do not walk on unit.

Unit	*Weight	
	Lbs.	Kg.
ZG	712	323
ZC	621	282
ZH	664	301

*Maximum weight with all available factory-installed accessories.

IMPORTANT - ALL PANELS MUST BE IN PLACE FOR RIGGING.



580744-02