

O23 / OHR23 / OF23 SERIES UNITS

O23 (Elite 80™) series units are mid-efficiency up-flow oil furnaces manufactured with Beckett oil burners. O23 units are available in heating capacities of 70,000 to 154,000 Btuh (20.5 to 45.1 kW) and cooling applications from 2 through 5 tons (7.0 through 17.6 kW). Refer to Engineering Handbook for proper sizing.

OHR23 (Elite 80™) series units are mid-efficiency horizontal / down-flow oil furnaces. The OF23 (Elite 80™) series units are mid-efficiency lo-boy up-flow oil furnaces, which come in front (OF23) or rear (OF23R) flue openings, both with Beckett oil burners. The OHR23 and OF23(R) units are available in heating capacities of 105,000 to 154,000 Btuh (30.8 to 45.1 kW) and cooling applications from 2 through 5 tons (7.0 through 17.6 kW). Refer to Engineering Handbook for proper sizing.

The drum type heat exchanger comes with strategically placed ports allowing easy cleaning, while the oil burner can be removed for inspection and service. The maintenance section gives a detailed description on how this is done.

Information contained in this manual is intended for use by experienced HVAC service technicians only. All specifications are subject to change. Procedures outlined in this manual are presented as a recommendation only and do not supersede or replace local or state codes.



O23 SHOWN

⚠ WARNING



Electric shock hazard. Can cause injury or death. Before attempting to perform any service or maintenance, turn the electrical power to unit OFF at disconnect switch(es). Unit may have multiple power supplies.

⚠ WARNING

Improper installation, adjustment, alteration, service or maintenance can cause property damage, personal injury or loss of life. Installation and service must be performed by a qualified installer or service agency.

TABLE OF CONTENTS

General	1
Specifications	2
Indoor Blower Data	4
Parts Arrangement	5
I Unit Components	7
II Placement and Installation	16
III Start Up	22
IV Heating Systems Service Checks	22
V Disassembling Burner	24
VI Typical Operating Characteristics	26
VII Maintenance	27
VIII Wiring Diagrams	28
IX Troubleshooting	31

SPECIFICATIONS - O23

Model Number		O23Q2-70	O23Q3-105/120	O23Q5-140/154
Input — Btuh (kW) low/high		70,000 (20.5)	105,000 / 120,000 (30.8 / 35.2)	140,000 / 154,000 (41.0 / 45.1)
Output — Btuh (kW) low/high		57,000 (16.7)	85,000 / 97,000 (24.9 / 28.4)	113,000 / 125,000 (33.1 / 36.6)
*A.F.U.E.		83.8%	82.8% (-105) / 82.5% (-120)	82.5% (-140) / 81.4% (-154)
Nozzle Rating — gph (L/hr) and spray angle		.50 (1.9) — 80° hollow	.65 (2.5) — 80° (-105 input) solid ●.75 (2.8) — 80° (-120 input) solid	.85 (3.2) — 80° (-140 input) solid ●1.00 (3.8) — 80° (-154 input) solid
Flue Size Diameter — in. (mm)		6 (152)	6 (152)	6 (152)
Oil Burner Pump		1 Stage	1 Stage	1 Stage
Oil Burner Pump Pressure — psig (Pa)		100 (690)	140 (965)	140 (965)
Blower wheel nominal diameter x width	in.	10 x 6	10 x 8	12 x 9
	mm	254 x 152	254 x 203	305 x 229
Blower Motor Output — hp (W)		1/3 (249)	1/3 (249)	3/4 (560)
Nominal cooling that can be added	Tons	2 thru 2.5	2 thru 3.5	3 thru 5
	kW	7.0 thru 8.8	7.0 thru 12.3	10.6 thru 17.6
**Number and size of filters — in. (mm)		(1) 16 x 25 x 1	(1) 16 x 25 x 1	†(2) 16 x 25 x 1
Shipping weight — lbs. (kg) 1 package		225 (102)	225 (102)	275 (125)
Electrical characteristics		115 volts — 60 hertz — 1 phase		
▼ Optional Accessories (Must Be Ordered Extra) ▼				
Two Stage Oil Pump		65A44		
Oil Filter		81P89		

*Annual Fuel Utilization Efficiency based on U.S. DOE test procedures and FTC labeling regulations. Isolated combustion system rating for non-weatherized furnaces.

**Cleanable frame type filters. Furnished with unit in Side Filter Adaptor Kit for field installation external to the cabinet.

†Requires return air from both sides of cabinet.

●Nozzle must be field provided for field conversion to higher heating input.

SPECIFICATIONS - OHR23

Model Number		OHR23Q3-105/120	OHR23Q5-140/154
Input — Btuh (kW) low/high		105,000 / 120,000 (30.8 / 35.2)	140,000 / 154,000 (41.0 / 45.1)
Output — Btuh (kW) low/high		85,000 / 97,000 (24.9 / 28.4)	113,000 / 125,000 (33.1 / 36.6)
*A.F.U.E. (low/high)		81.8% / 81.3%	81.5% / 81.7%
Nozzle Rating — U.S. gph (L/hr) and spray angle		.65 (2.5) — 80° (-105 input) solid ●.75 (2.8) — 80° (-120 input) solid	.85 (3.2) — 80° (-140 input) solid ●1.00 (3.8) — 80° (-154 input) solid
Flue Size Diameter — in. (mm)		6 (152)	6 (152)
Oil Burner Pump		1 Stage	1 Stage
Oil Burner Pump Pressure — psig (Pa)		140 (965)	140 (965)
Blower wheel nominal diameter x width — in. (mm)		10 x 10 (254 x 254)	12 x 9 (305 x 229)
Blower motor output — hp (W)		1/2 (373)	3/4 (560)
Nominal cooling that can be added	Tons	2 to 3	3 to 5
	kW	7.0 to 10.6	10.6 to 17.6
Shipping weight — lbs. (kg) 1 package		225 (102)	265 (120)
Electrical characteristics		115 volts — 60 hertz — 1 phase	
▼ Optional Accessories (Must Be Ordered Extra) ▼			
Two Stage Oil Pump		65A44	
Filter Kit	Catalog no.	35K01	35K06
	No. & size of filters — in. (mm)	(2) 10-1/4 x 20-1/2 x 1 (260 x 521 x 25)	(2) 11-3/4 x 23-1/2 x 1 (298 x 597 x 25)
Down-flo Additive Base		35K07	35K08
Horizontal Venting Kit		62J01	
Burner Cover		84H26	
Vestibule Cover Kit (full front cover)		37K28	37K29
Oil Filter		81P89	

*Annual Fuel Utilization Efficiency based on U.S. DOE test procedures and FTC labeling regulations. Isolated combustion system rating for non-weatherized furnaces.

●Nozzle must be field provided for field conversion to higher heating input.

SPECIFICATIONS - OF23

Model Number		OF23Q3-105/120 OF23Q3-105/120R	OF23Q5-140/154 OF23Q5-140/154R
Input — Btuh (kW) low/high		105,000 / 120,000 (30.8 / 35.2)	140,000 / 154,000 (41.0 / 45.1)
Output — Btuh (kW) low/high		85,000 / 97,000 (24.9 / 28.4)	113,000 / 125,000 (33.1 / 36.6)
*A.F.U.E. (low/high)		82.4% / 81.5% 82.5% / 82.4% R Models	81.8% / 81.5% 82.0% / 81.8% R Models
Nozzle Rating — gph (L/hr) and spray angle		.65 (2.5) — 80° (-105 input) ●.75 (2.8) — 80° (-120 input)	.85 (3.2) — 80° (-140 input) ●1.00 (3.8) — 80° (-154 input)
Flue Size Diameter — in. (mm)		6 (152)	6 (152)
Oil Burner Pump		1 Stage	1 Stage
Oil Burner Pump Pressure — psig (Pa)		140 (965)	140 (965)
Optional 2 Stage Fuel Pump		65A44	
Blower wheel nominal diameter x width	in.	10 x 8	12 x 9
	mm	254 x 203	305 x 229
Blower Motor Output — hp (W)		1/3 (249)	3/4 (560)
Nominal cooling that can be added — Tons (kW)		2 thru 3 (7.0 thru 10.6)	3 thru 5 (10.6 thru 17.6)
Number and size of filters	in.	(1) 18 x 19 x 1	(1) 19 x 21 x 1
	mm	(1) 457 x 483 x 25	(1) 483 x 533 x 25
Shipping weight — lbs. (kg) 1 package		255 (116)	290 (132)
Electrical Characteristics		115 — 60 hertz — 1 phase	
▼ Optional Accessories (Must Be Ordered Extra) ▼			
Two Stage Oil Pump		65A44	
Oil Filter		91P89	

*Annual Fuel Utilization Efficiency based on U.S. DOE test procedures and FTC labeling regulations. Isolated combustion system rating for non-weatherized furnaces.
 ●Nozzle must be field provided for field conversion to higher heating input.

BLOWER PERFORMANCE DATA - O23

O23Q2-70 BLOWER PERFORMANCE

External Static Pressure		Air Volume at Various Blower Speeds					
		High		Medium		Low	
in. w.g.	Pa	cfm	L/s	cfm	L/s	cfm	L/s
.20	50	1260	595	870	410	520	245
.30	75	1205	570	825	390	500	235
.40	100	1135	535	780	370	480	225
.50	125	1050	495	720	340	450	210
.60	150	960	455	660	310	410	195

NOTE — All air data is measured external to the unit with the air filter in place.

O23Q3-105/120 BLOWER PERFORMANCE

External Static Pressure		Air Volume at Various Blower Speeds					
		High		Medium		Low	
in. w.g.	Pa	cfm	L/s	cfm	L/s	cfm	L/s
.20	50	1350	635	1215	575	1080	510
.30	75	1280	605	1180	555	1060	500
.40	100	1210	570	1140	540	1040	490
.50	125	1180	444	1085	510	1000	470
.60	150	1100	520	1025	485	950	450

NOTE — All air data is measured external to the unit with the air filter in place.

O23Q5-140/154 BLOWER PERFORMANCE

External Static Pressure		Air Volume at Various Blower Speeds					
		High		Medium		Low	
in. w.g.	Pa	cfm	L/s	cfm	L/s	cfm	L/s
.20	50	1950	920	1620	765	1250	590
.30	75	1900	895	1590	750	1230	580
.40	100	1880	885	1560	735	1210	570
.50	125	1850	875	1540	725	1190	560
.60	150	1800	850	1490	705	1155	545

NOTE — All air data is measured external to the unit with the air filter in place.

BLOWER PERFORMANCE DATA - OHR23

OHR23Q3-105/120 BLOWER PERFORMANCE

External Static Pressure		Air Volume at Various Speeds					
		High		Medium		Low	
in. w.g.	Pa	cfm	L/s	cfm	L/s	cfm	L/s
.20	50	1470	695	1360	640	1070	505
.30	75	1400	660	1300	615	1040	490
.40	100	1330	630	1230	580	1020	480
.50	125	1260	595	1160	545	980	460
.60	150	1180	555	1085	510	920	435

NOTE — All air data is measured external to the unit with air filter in place.

OHR23Q5-140/154 BLOWER PERFORMANCE

External Static Pressure		Air Volume at Various Speeds					
		High		Medium		Low	
in. w.g.	Pa	cfm	L/s	cfm	L/s	cfm	L/s
.20	50	1950	920	1700	800	1340	630
.30	75	1920	905	1650	780	1300	615
.40	100	1900	895	1600	755	1270	600
.50	125	1870	880	1580	745	1220	575
.60	150	1780	840	1500	710	1170	550

NOTE — All air data is measured external to the unit with air filter in place.

BLOWER PERFORMANCE DATA - OF23

FRONT FLUE MODELS

OF23Q3-105/120 BLOWER PERFORMANCE

External Static Pressure		Air Volume at Various Blower Speeds					
		High		Medium		Low	
in. w.g.	Pa	cfm	L/s	cfm	L/s	cfm	L/s
.20	50	1490	705	1370	645	1190	560
.30	75	1430	675	1345	635	1180	555
.40	100	1375	650	1280	605	1160	545
.50	125	1300	615	1230	580	1120	530
.60	150	1230	580	1160	545	1080	510

NOTE — All air data is measured external to the unit with the air filter in place.

OF23Q5-140/154 BLOWER PERFORMANCE

External Static Pressure		Air Volume at Various Blower Speeds					
		High		Medium		Low	
in. w.g.	Pa	cfm	L/s	cfm	L/s	cfm	L/s
.20	50	2110	995	1850	875	1500	710
.30	75	2035	960	1810	855	1480	700
.40	100	1970	930	1750	825	1450	685
.50	125	1950	920	1690	800	1420	670
.60	150	1880	885	1620	765	1375	650

NOTE — All air data is measured external to the unit with the air filter in place.

REAR FLUE MODELS

OF23Q3-105/120R BLOWER PERFORMANCE

External Static Pressure		Air Volume at Various Blower Speeds					
		High		Medium		Low	
in. w.g.	Pa	cfm	L/s	cfm	L/s	cfm	L/s
.20	50	1470	695	1330	630	1150	545
.30	75	1410	665	1295	610	1140	540
.40	100	1340	630	1250	590	1125	530
.50	125	1280	605	1190	560	1080	510
.60	150	1205	670	1130	535	1030	485

NOTE — All air data is measured external to the unit with the air filter in place.

OF23Q5-140/154R BLOWER PERFORMANCE

External Static Pressure		Air Volume at Various Blower Speeds					
		High		Medium		Low	
in. w.g.	Pa	cfm	L/s	cfm	L/s	cfm	L/s
.20	50	2010	950	1765	835	1380	650
.30	75	1960	925	1720	810	1350	635
.40	100	1900	895	1660	785	1330	630
.50	125	1880	885	1600	755	1295	610
.60	150	1800	850	1560	735	1230	580

NOTE — All air data is measured external to the unit with the air filter in place.

O23 GENERAL PARTS ORIENTATION

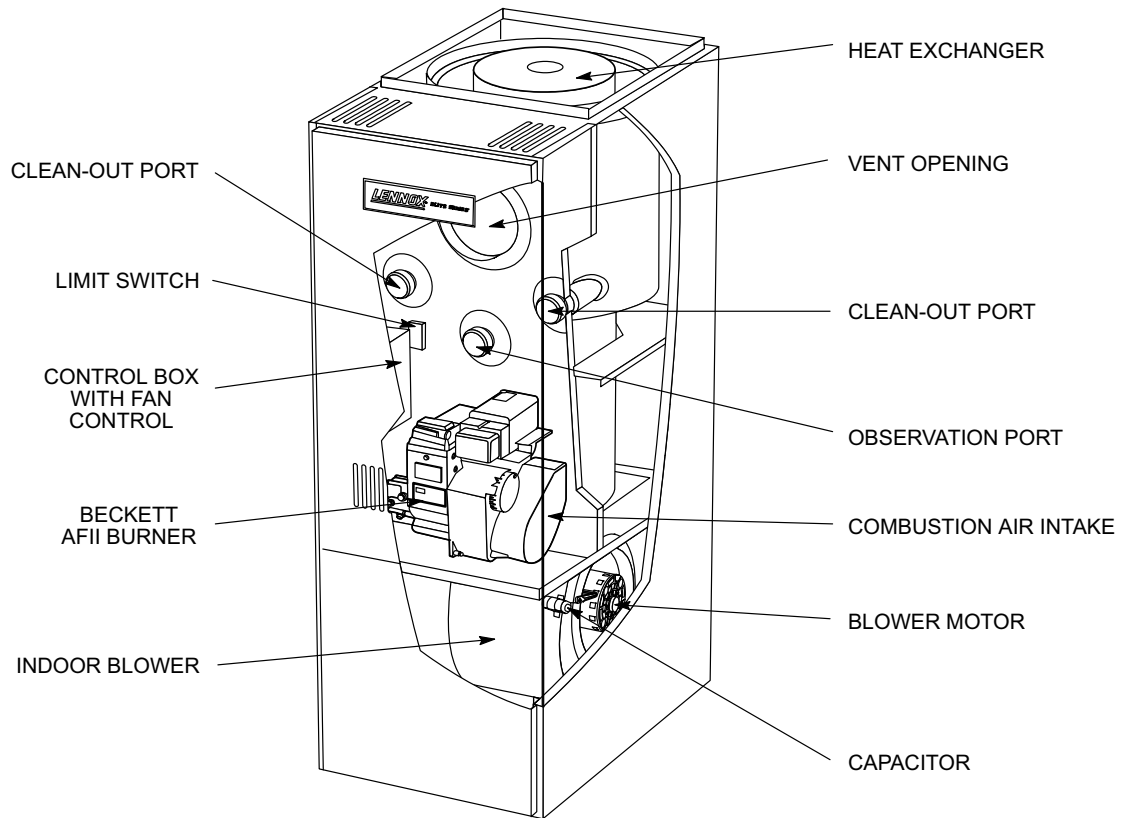

FIGURE 1

OHR23 GENERAL PARTS ORIENTATION

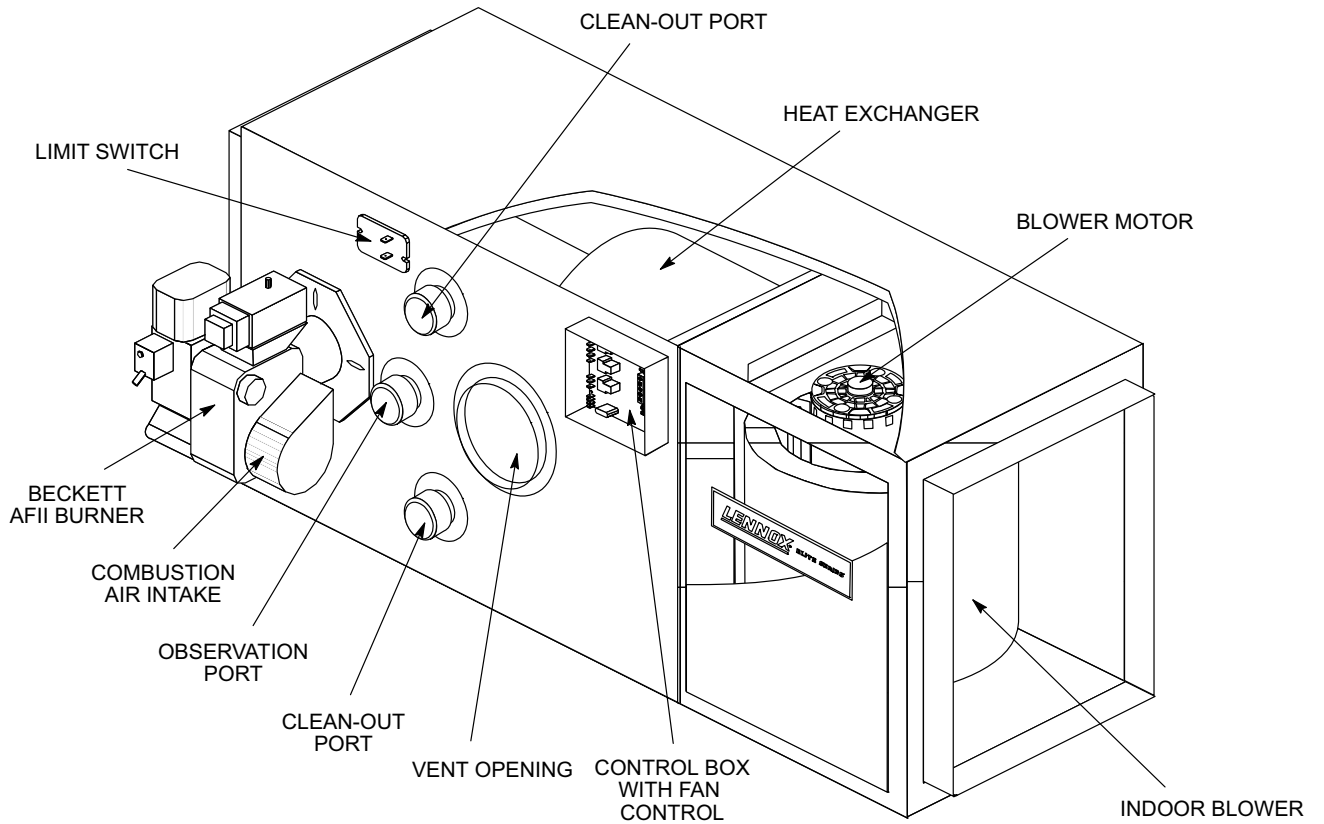

FIGURE 2

OF23 GENERAL PARTS ORIENTATION

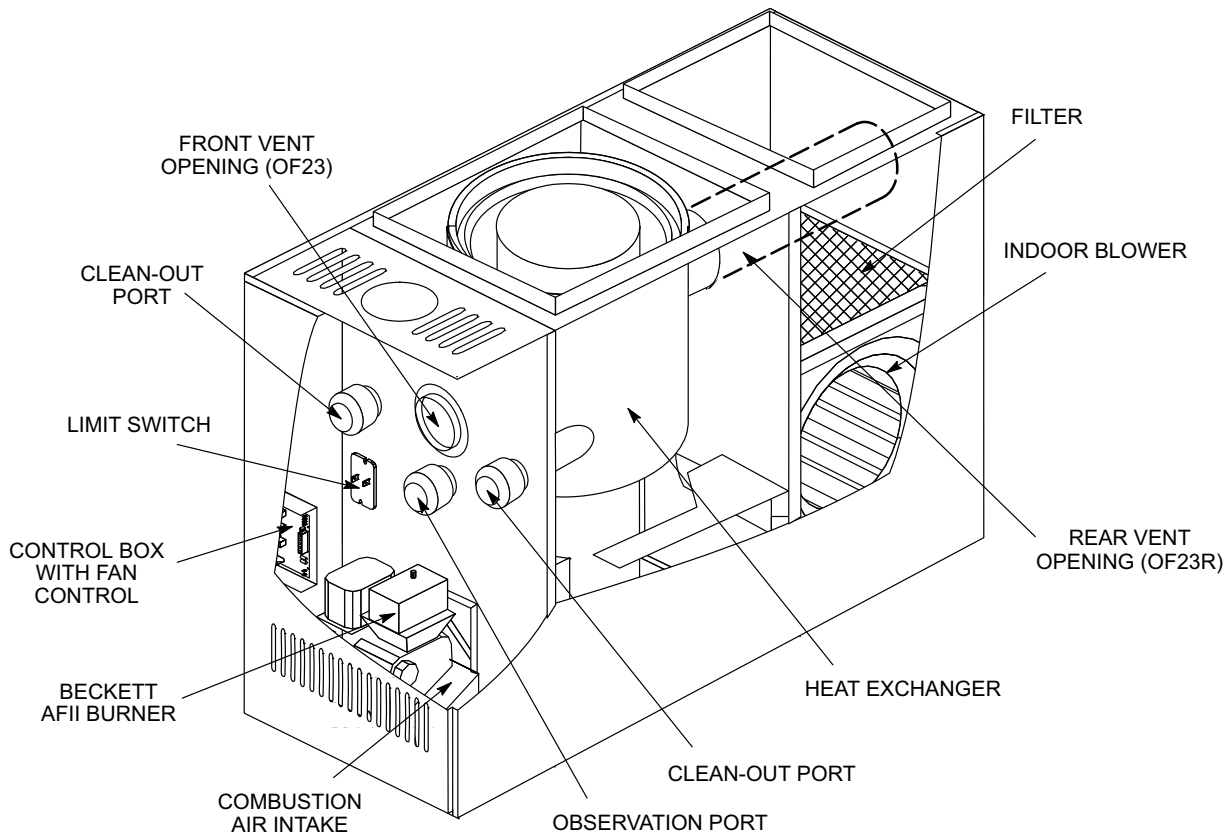

FIGURE 3

BCC2 / BCC3 BLOWER CONTROL BOARD

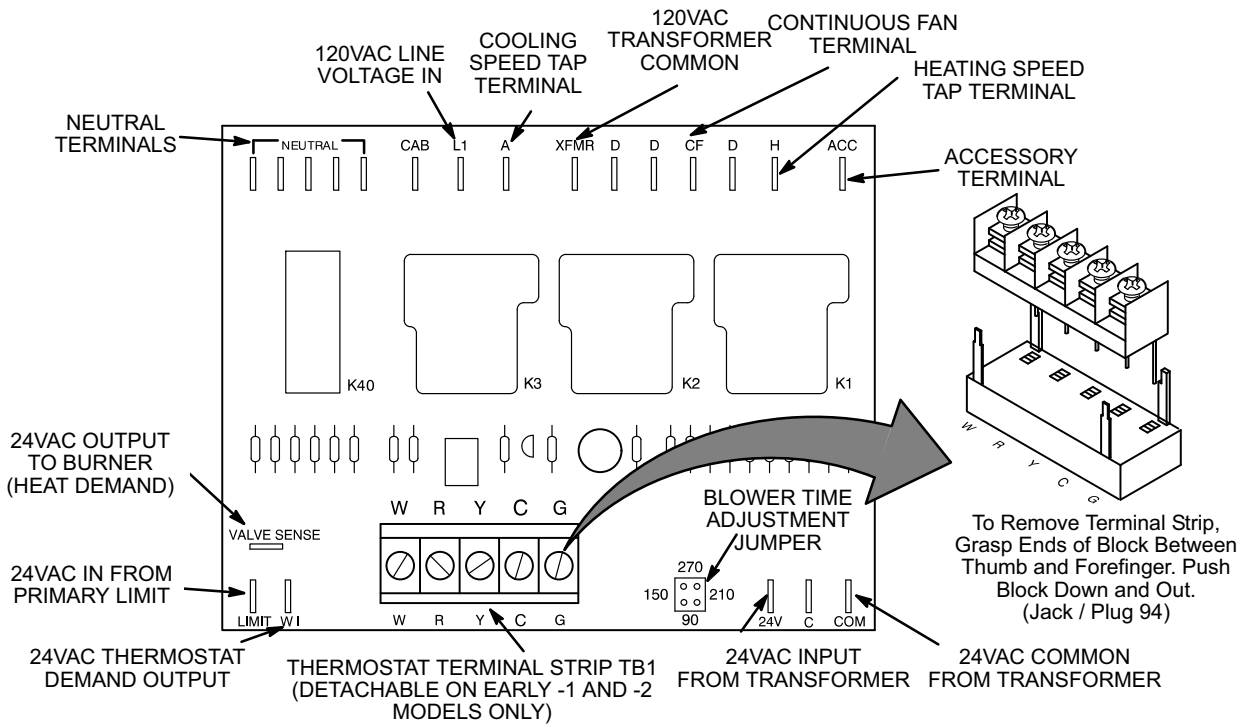

FIGURE 4

I-UNIT COMPONENTS

General parts orientation for the O23, OHR23 and OF23 are shown in figures 1, 2 and 3 respectively. The O23 and OF23 control box, burner, limit switch and clean-out ports may be accessed by removing the front access panel, while the OHR23 components are exposed. The blower can be accessed in the O23 and OF23 by removing the blower access panel, while in the OHR23 units two 1/4" screws must be removed before the blower access panel can be removed.

ELECTROSTATIC DISCHARGE (ESD) Precautions and Procedures

⚠ CAUTION

Electrostatic discharge can affect electronic components. Take precautions during unit installation and service to protect the unit's electronic controls. Precautions will help to avoid control exposure to electrostatic discharge by putting the unit, the control and the technician at the same electrostatic potential. Neutralize electrostatic charge by touching hand and all tools on an unpainted unit surface before performing any service procedure.

A-Blower Control Board

BCC2 Blower Control Board (Figure 4) -1 and -2 units

All O23, OHR23 and OF23-1 and -2 oil units utilize the BCC2 (A15) blower control manufactured by Heatcraft. The BCC2 is a printed circuit board which controls the supply air blower and monitors the limit controls and oil burner operation. The control has a non-adjustable, factory preset "fan-on" timing. Fan "off" timing is adjustable. The board is divided into two sections, 120 and 24VAC. Line voltage comes into the board on the 120VAC side. See figure 4. See table 1 for BCC2 terminal designations.

⚠ DANGER

Shock hazard. Avoid personal injury. Make sure to disconnect power before changing fan "off" timing.

Blower Operation and Timing

Blower "off" timing (time that the blower operates after the heat demand has been satisfied) is determined by the arrangement of a jumper across pins on the BCC2 blower control board. See figure 4. To adjust fan "off" timing, gently disconnect jumper and reposition across pins corresponding with new timing. Fan "on" time is factory set at 45 seconds and is not adjustable.

NOTE—If fan "off" time is set too low, residual heat in heat exchanger may cause primary limit S10 or auxiliary limit S21 to trip resulting in frequent cycling of blower. If this occurs, adjust blower to longer time setting.

Figure 5 shows the various fan "off" timings and how jumper should be positioned. Unit is shipped with a factory fan "off" setting of 150 seconds. Fan "off" time will affect comfort and efficiency and is adjustable to satisfy individual applications. The fan "off" timing is initiated after a heating demand but not after a blower or cooling demand (that is, when indoor thermostat switch is changed from ON to AUTO and heating/cooling demand is not present, the blower stops immediately).

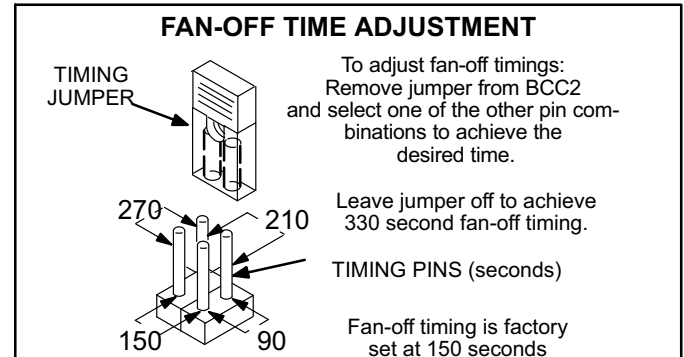

FIGURE 5

Thermostat Connection

Thermostat wires are connected to terminal strip TB1 found on the BCC2 control board. The terminal strip is clearly marked with the corresponding thermostat designation. The terminal strip (jack / plug 94) is simply removed by grasping the ends of the block and rotating down while pulling away (see figure 4).

TABLE 1

BLOWER CONTROL A15 TERMINAL DESIGNATIONS		
Terminal	Type	Function
W	Detachable Screw Strip	Heating Demand
R	Detachable Screw Strip	24VAC to Thermostat
Y	Detachable Screw Strip	Cooling Demand
C	Detachable Screw Strip	24VAC Common To Indoor Thermostat
G	Detachable Screw Strip	Blower Demand
NEUTRAL	1/4" Spade	120VAC Neutral
L1	1/4" Spade	120VAC Line Voltage In
A	1/4" Spade	Switched 120VAC to Blower Cooling Tap
XFMRN	1/4" Spade	120VAC Transformer Common
CF	1/4" Spade	Switched 120VAC to Continuous Blower Tap
H	1/4" Spade	Switched 120VAC to Blower Heating Tap
ACC	1/4" Spade	Switched 120VAC to Accessory (Electronic Air Cleaner, Humidifier, Etc. 1 amp rating.)
VALVE SENSE	3/16" Spade	24VAC Output To Burner
LIMIT	1/4" Spade	24VAC In From Primary Limit. Limit Open: Stops Burner and Turns On Blower. Limit Closed: Allows Burner Operation
WI	1/4" Spade	24VAC Thermostat Demand Output
24V	1/4" Spade	24VAC Input From Transformer
COM	1/4" Spade	24VAC Common From Transformer

BCC3 Blower Control Board (Figure 4)

-3 and -4 units

All O23, OHR23 and OF23-3 and -4 oil units utilize the BCC3 (A15) blower control manufactured by Heatcraft. The BCC3 is a printed circuit board which controls the supply air blower and monitors the limit controls and oil burner operation. The control has a non-adjustable, factory preset "fan-on" timing. Fan "off" timing is adjustable. The board is divided into two sections, 120 and 24VAC. Line voltage comes into the board on the 120VAC side. See figure 4. See table 2 for BCC3 terminal designations.

⚠ DANGER

Shock hazard. Avoid personal injury. Make sure to disconnect power before changing fan "off" timing.

Blower Operation and Timing

Blower "off" timing (time that the blower operates after the heat demand has been satisfied) is determined by the arrangement of a jumper across pins on the BCC3 blower control board. See figure 4. To adjust fan "off" timing, gently disconnect jumper and reposition across pins corresponding with new timing. Fan "on" time is factory set at 45 seconds and is not adjustable.

NOTE—If fan "off" time is set too low, residual heat in heat exchanger may cause primary limit S10 or auxiliary limit S21 to trip resulting in frequent cycling of blower. If this occurs, adjust blower to longer time setting.

Figure 5 shows the various fan "off" timings and how jumper should be positioned. Unit is shipped with a factory fan "off" setting of 150 seconds. Fan "off" time will affect comfort and efficiency and is adjustable to satisfy individual applications. The fan "off" timing is initiated after a heating demand but not after a blower or cooling demand (that is, when indoor thermostat switch is changed from ON to AUTO and heating/cooling demand is not present, the blower stops immediately).

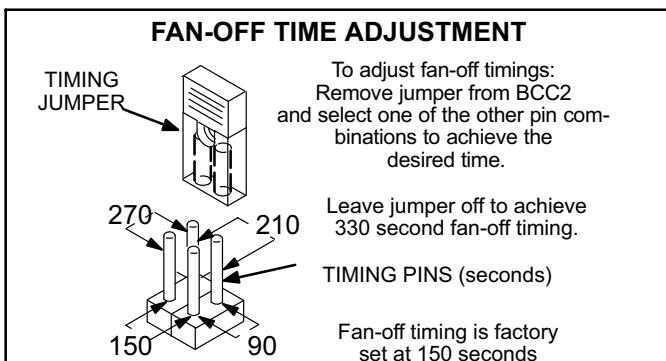

FIGURE 6

Thermostat Connection

Thermostat wires are connected to terminal strip TB1 found on the BCC3 control board. The terminal strip is clearly marked with the corresponding thermostat designation. The terminal strip (jack / plug 94) is simply removed by grasping the ends of the block and rotating down while pulling away (see figure 4).

TABLE 2

BLOWER CONTROL A15 TERMINAL DESIGNATIONS		
Terminal	Type	Function
W	Detachable Screw Strip	Heating Demand
R	Detachable Screw Strip	24VAC to Thermostat
Y	Detachable Screw Strip	Cooling Demand
C	Detachable Screw Strip	24VAC Common To Indoor Thermostat
G	Detachable Screw Strip	Blower Demand
NEUTRAL	1/4" Spade	120VAC Neutral
L1	1/4" Spade	120VAC Line Voltage In
A	1/4" Spade	Switched 120VAC to Blower Cooling Tap
XFMRN	1/4" Spade	120VAC Transformer Common
CF	1/4" Spade	Switched 120VAC to Continuous Blower Tap
H	1/4" Spade	Switched 120VAC to Blower Heating Tap
ACC	1/4" Spade	Switched 120VAC to Accessory (Electronic Air Cleaner, Humidifier, Etc. 4 amp rating.)
VALVE SENSE	3/16" Spade	24VAC Output To Burner
LIMIT	1/4" Spade	24VAC In From Primary Limit. Limit Open: Stops Burner and Turns On Blower. Limit Closed: Allows Burner Operation
WI	1/4" Spade	24VAC Thermostat Demand Output
24V	1/4" Spade	24VAC Input From Transformer
COM	1/4" Spade	24VAC Common From Transformer

ST9103A Blower Control Board (Figure 8)

-5 units

All O23, OHR23 and OF23 -5 oil units utilize the ST9103A (A15) blower control manufactured by Honeywell. The ST9103A is a printed circuit board which controls the supply air blower and monitors the limit controls and oil burner operation. The control has a non-adjustable, factory preset "fan-on" timing. Fan "off" timing is adjustable. See figure 8 and table 3 for ST9103A terminal designations

⚠ DANGER

Shock hazard. Avoid personal injury. Make sure to disconnect power before changing fan "off" timing.

Blower Operation and Timing

The fan on time of 30 seconds is not adjustable. Fan off time (time that the blower operates after the heat demand has been satisfied) can be adjusted by moving the delay switches on the fan control board. Fan off time will affect comfort and is adjustable to satisfy individual applications. See figure 7. Set the heat fan off delay switches to either 60, 90, 120, or 150 seconds. The factory setting is 90 seconds.

NOTE—If fan "off" time is set too low, residual heat in heat exchanger may cause primary limit S10 or auxiliary limit S21 to trip resulting in frequent cycling of blower. If this occurs, adjust blower to longer time setting.

Thermostat Connection

Thermostat wires are connected directly to the terminals on the ST9103A board. See figure 8.

Continuous Blower

If the ST9103A blower control board is wired for continuous blower, the blower will energized on low speed and remain energized when heat or cool demand is satisfied. Continuous blower will also energized when indoor thermostat is left in the OFF mode.

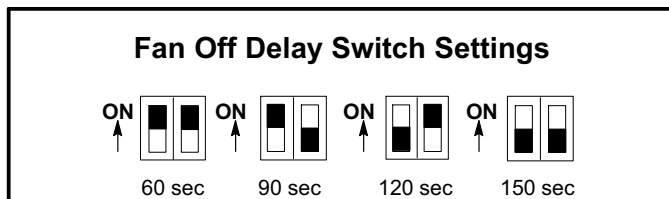

Figure 7

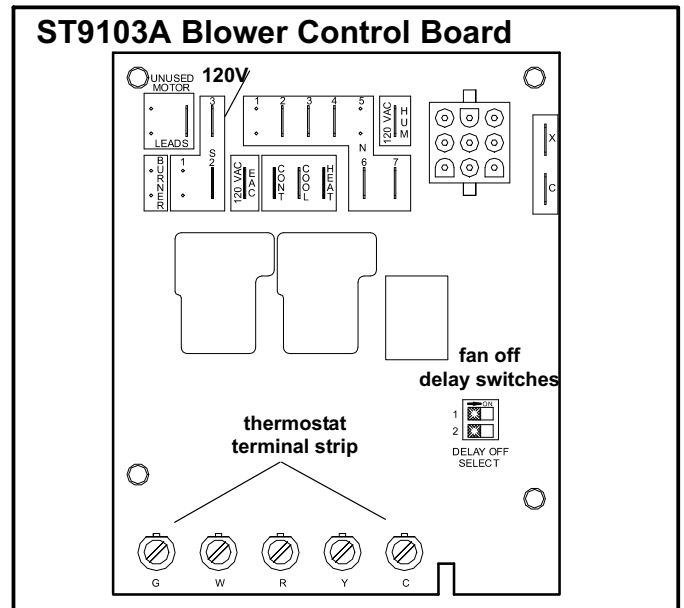

Figure 8

TABLE 3

BLOWER CONTROL A15 TERMINAL DESIGNATIONS	
J58 Pin #	Function
1	Limit S10
2	L1 120V
3	T1 24V
4	L2 Common
5	Jumpered to Pin 4
6	T2 24V
7	Combustion Air Inducer 120V
8	Jumpered to Pin 7
9	Limit S21 (if used)
Thermostat Connections	
G	Blower Demand
W	Heating Demand
R	24V
Y	Cooling Demand
C	Common
24 VAC CONNECTIONS	
X	24V Transformer
C	Common Transformer
120 VAC	
S2	Line
S3	120V To Transformer
N, 2, 3, 4, 6, 7	Neutral
CONT	Continuous Blower
COOL	Cool Tap
HEAT	Heat Tap

-1THROUGH -4 UNIT OIL BURNER PARTS ARRANGEMENT

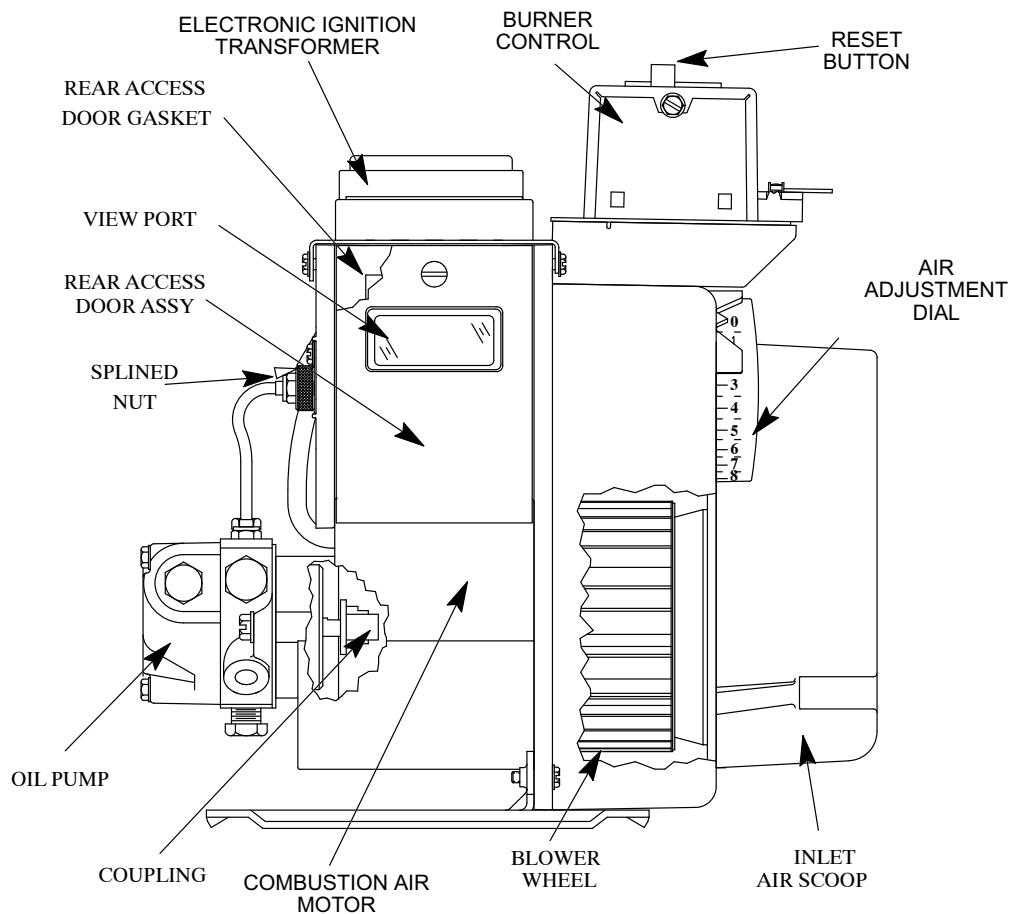
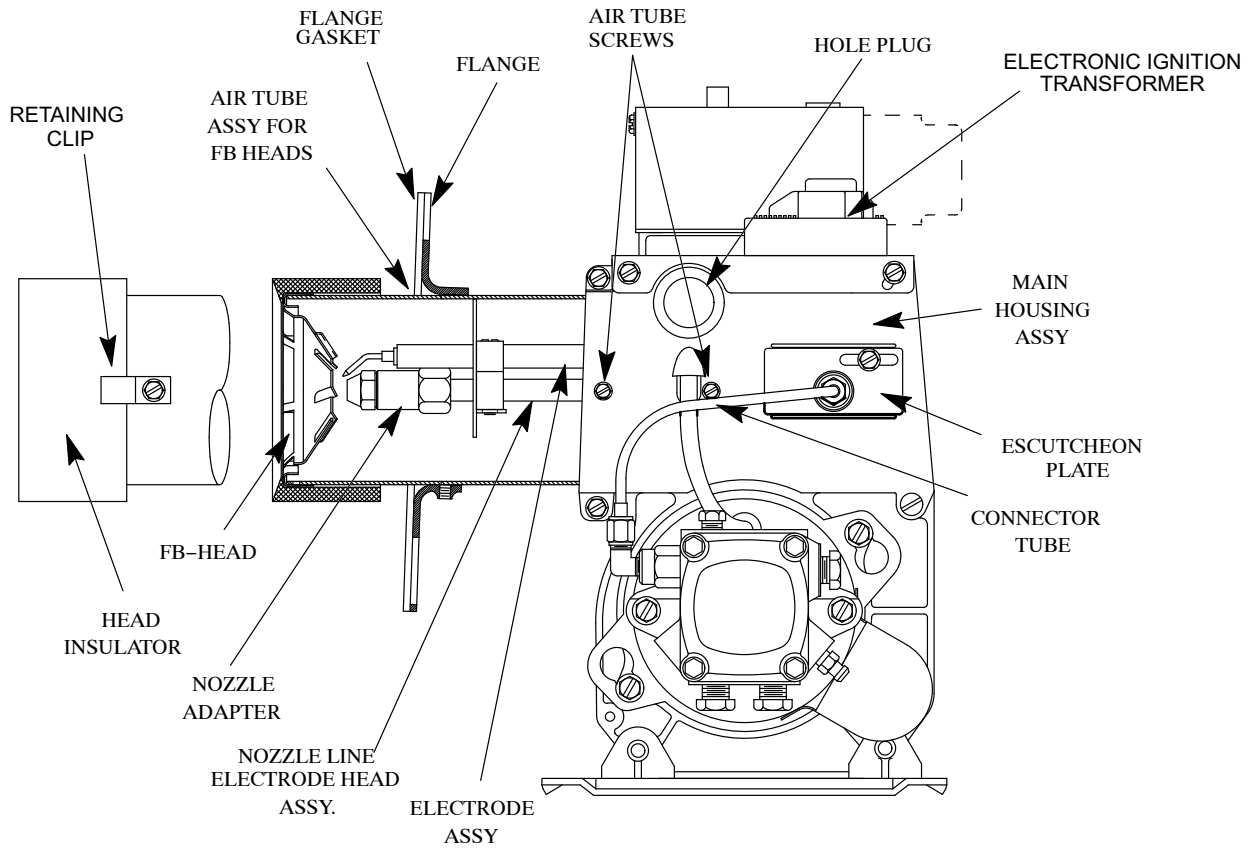

FIGURE 9

-5 UNIT BURNER PARTS ARRANGEMENT

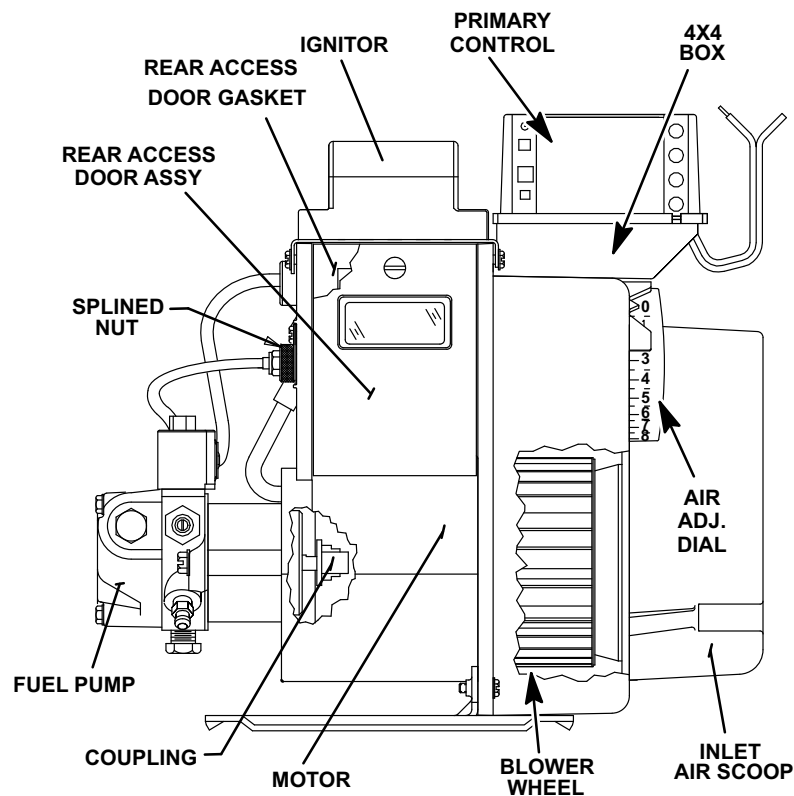
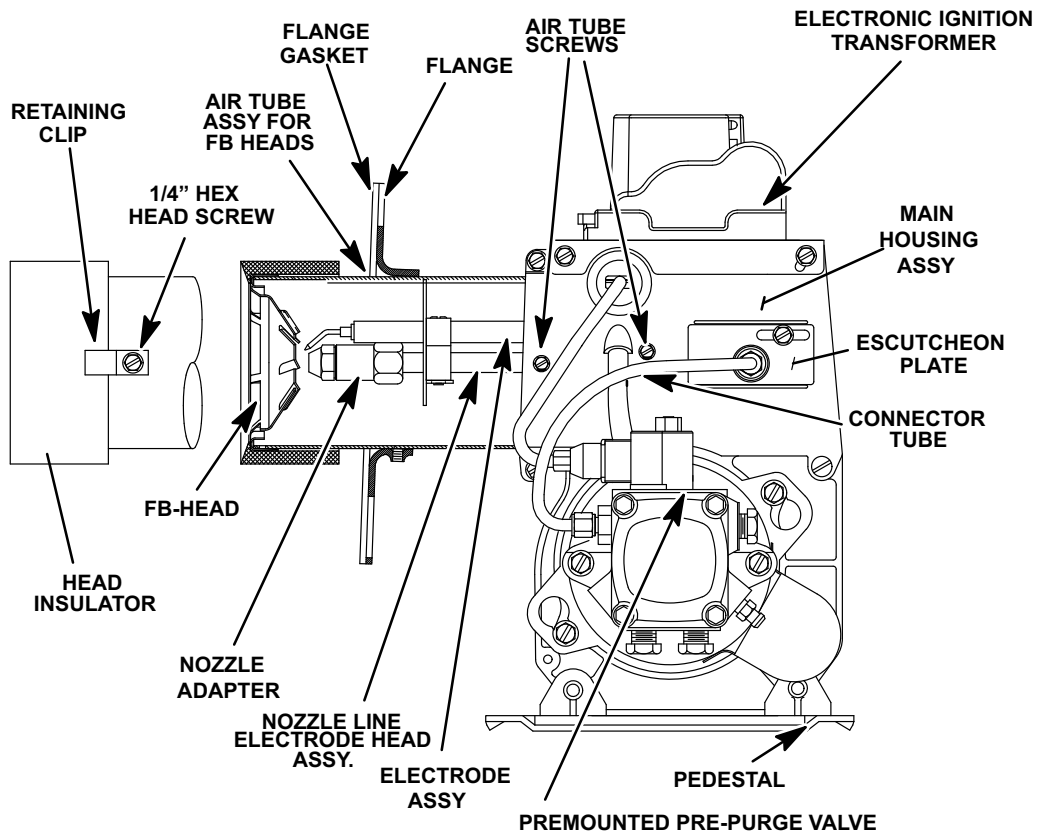

FIGURE 10

TABLE 4

FURNACE / BURNER SPECIFICATIONS							
Unit	Lennox Burner Part Number	Burner Model	*Initial Air Dial Setting	Output	Nozzle Size (Delevan)	Pump Pressure	Head
-70	35K74	AFII 85	3.0	57,000 BTU (16.7 kW)	0.50 X 80° A	100 psig (689.5 kPa)	FB0
-105	35K75	AFII 85	4.0	84,000 BTU (24.6 kW)	0.65 X 80° B	140 psig (965.3 kPa)	FB3
-120	35K75	AFII 85	4.5	105,000 BTU (30.8 kW)	0.75 X 80° B	140 psig (965.3 kPa)	FB3
-140	35K76	AFII 150	6.0	112,000 BTU (32.8 kW)	0.85 X 80° B	140 psig (965.3 kPa)	FB6
-154	35K76	AFII 150	6.5	125,000 BTU (36.6 kW)	1.00 X 80° B	140 psig (965.3 kPa)	FB6

*NOTE: The initial air dial setting is provided to get unit started. The air dial setting **MUST** be adjusted after start-up to achieve proper combustion.

B-Burner (Figures 9 & 10)

The O23, OHR23, and OF23 oil furnaces use the Beckett AFII burner. The oil burner provides an atomized oil vapor mixed with the correct proportion of air when it is ignited in the combustion chamber. Oil burner minimum and maximum ratings are listed on the unit nameplate. Proper air adjustment for these ratings is achieved through the air adjustment dial. Set air dial to the initial air dial setting (see table 4). After start up adjust air dial to achieve proper combustion. Remember to tighten set screw on air dial.

The AFII burner is available in five sizes with either a single or two stage pump. Table 4 identifies the burners used in Lennox units. Figures 9 and 10 show the typical layout of the burner assembly.

1-Combustion Air Blower / Pump Motor (B6)

The burner is activated by the primary control. A combustion air blower is mounted on the motor shaft. The motor shaft also connects to the direct drive oil pump through a coupler. The burner motor turns both the combustion air blower and the oil pump. The motor operates at 3500 RPM.

Burner motors are overload protected. In the event of excess motor temperature or current, the overload opens to de-energize the motor. The overload automatically resets after temperature has returned to normal. Keep motor clean to prevent starting switch from sticking. All AFII motors are permanently lubricated. No further oiling is required.

**2-Combustion Air Blower / Pump Fuse (F22)
(-140 and -154 CSA units only)**

In the -140 and -154 Canadian units an in line fuse (F22) is used between the line voltage from the BCC2 blower control and the blower / pump motor. The fuse is rated at 300 volts and 15 amps.

3- Pump (-1 through -4 units)

The O23, OHR23, and OF23 oil furnaces use a single stage, 3450 RPM pump. A two stage pump is available as an option (catalog # 65A44). The oil burner is shipped from factory for use in a single line system. To convert the pump to a two line system, install the bypass plug provided in the attached bag according to the accompanying instructions.

4- Pump (-5 units only)

The O23, OHR23 and OF23-5 units all utilize the Cleancut Fuel Unit manufactured by Becket. This pump uses a solenoid valve to control the piston cut-on cut-off operation instead of a cone valve and diaphragm used by other conventional pumps. The solenoid works with the R7184B Honeywell burner control to provide cut-on cut-off operation while the burner motor is at full speed.

At startup the pump shaft is brought to full speed before the solenoid is energized. At this time low pressure oil (approximatley 20-25 psi) from the gearset circulates around the pressure regulator piston which is closed and through the open solenoid valve. The solenoid valve returns the oil to either the cover cavity (one pipe) or return line (two pipe). When the solenoid vavle is energized, it closes (and remains closed while energized) blocking the return path to the cover cavity and return line creating pressure build up in the piston cavity. The piston opens and regulates pressure and delivers pressurized oil to the nozzle.

At shutdown the solenoid valve will de-energize and open before the pump shaft rotation stops. When the solenoid valve opens the oil by-passes the cover cavity and return line causing a pressure drop in the piston cavity. The piston closes blocking oil to the nozzle while the burner motor is running at full speed.

5-Burner Control (A3) & Transformer (T1)

-1 through -4 units

The burner control, along with the matching cad cell, proves flame and controls the burner. After the cad cell closes a circuit to the burner control, the burner control de-energizes the safety switch heater to allow the unit to operate normally. The burner control allows 45 seconds for the cad cell to close. If the cad cell remains open after the 45 second time frame, the burner control locks out. The burner control must be manually reset by depressing the red reset button on top of the burner control.

Transformer (T1) is part of the burner control. T1 provides 24VAC to the low voltage components in the unit and to the thermostat.

6-Burner Control (A3) -5 units

All O 23, OHR23 and OF23 -5 units are equipped with a burner control R7184B manufactured by Honeywell. The burner control, along with the matching cad cell, proves flame and controls the burner. An LED on the control shows unit status. See table 5 for status codes. After the cad cell closes a circuit to the burner control, the burner control de-energizes the safety switch heater to allow the unit to operate normally. When there is a call for heat the control performs a 2 to 6 second delay safety check. Once this is established a 15 second pre-purge will follow. The valve then opens for a 15 second trial for ignition. If flame is not sensed during the 15 second trial, the control shuts down and must be manual re-set. After three consecutive lockouts the control goes into restricted lockout. Once flame is established after 10 seconds of run time, the ignition shuts off.

If flame is lost during the heat cycle the control will shut down the burner and begin a 60 second recycle delay. After 60 seconds the control repeats the ignition process. If flame is lost three consecutive times during a single thermostat demand the control goes into restricted lockout.

Reset button

If the control lockouts three consecutive times the control will go into restricted lockout. To reset control hold down the reset button for 30 seconds until the LED flashes twice. At any time the burner motor is energized, press and hold the reset button to disable the burner. The burner will remain disabled as long as the reset button is held and return to operational once the button is released.

TABLE 5

LED	STATUS
On	Flame sensed
Off	Flame not sensed
Flashing (1/2 sec on 1/2 sec off)	Lockout / Restricted Lockout
Flashing (2 sec on 2 sec off)	Recycle

7-Heat Shutoff Relay (K125)

-1 and -2 units only

Heat shutoff relay K125 is a SPST N.O. relay, with a 24V coil. K125 is located on the vestibule and wired in series with the burner. When secondary limit S21 or primary limit S10 open, the circuit breaks opening K125 contacts which in turn de-energizes the burner.

8-Cad Cell (R26)

Together the cad cell and the burner control prove flame. The cad cell senses the presence of burner light (less resistance) to close a circuit to the burner control.

IMPORTANT-Burner should not be installed so it is exposed to direct sunlight or electric bulb light. If the cell is exposed to light on start up, the burner will not operate.

O23, OHR23 & OF23 -5 Units Only

Resistance for the cad cell can be checked while the burner is firing and after ignition is off. Press (1/2 second or less) and release the reset button. The LED will flash 1 to 4 times depending on the cad cell resistance. The cad cell resistance should read less than 1600 Ohms. See table 6.

TABLE 6
O23, OHR23 & OF23 -5 UNITS

LED FLASHES	RESISTANCE
1	0 - 400 Ohms
2	400 - 800 Ohms
3	800 - 1600 Ohms
4	≥ 1600 Ohms

9-Electronic Ignitor (A73)

The electronic ignitor provides the needed hot spark at the electrodes to ignite the fuel mixture. The ignitor is a solid state transformer . O23, OHR23 and OF23-1 through -4 units have 115V primary and 14,000V secondary windings. O23, OHR23 and OF23-5 units have 120V primary and 20,000V secondary windings. The center of the secondary winding is grounded. Each secondary terminal is 7000V to ground and the total voltage between the electrodes is 14,000V.

NOTE-The leads for the solid state transformer are replaceable and are available in a kit form.

NOTE-When testing the solid state transformer, do not use a transformer tester designed for iron magnet transformers. Damage to the tester may result.

Testing the Ignitor

WARNING

SHOCK HAZARD

Do not touch ignitor or any metal touching ignitor when ignitor is energized. Can result in serious personal injury.

If the ignitor fails it will not produce a spark. Looking and listening for the arc is a simple way to check. The most sure way is to perform the screwdriver check. By placing the blade of an insulated screwdriver across the ignitor terminal leads will test for an arc. First, remove power from the burner and disconnect the oil supply from nozzle. The cad cell will not let the control energize the ignitor if the cad cell senses light. Therefore remove one lead of the cad cell from the burner control, or remove the cad cell all together (do not forget to put back when test is complete). Place the screwdriver blade across the terminals and slowly raise one end of the blade off the terminal while the other remains in contact with the other terminal. There should be an arc from terminal to the blade up to 3/4" away. If not replace the ignitor. If an arc is present then place one end of the screwdriver on one terminal and the other end with the grounded baseplate. Raise the blade from the baseplate and draw an arc. Repeat with the other terminal. If the arc from the baseplate to one terminal is weaker than the arc from the baseplate to the other terminal, replace the ignitor.

10-Gun Assembly

The gun assembly receives oil from the oil pump and feeds it to the nozzle. The nozzle converts liquid oil into a fog-like mist that is discharged through the flame retention head into the combustion chamber.

11-Flame Retention Heads

The stainless steel flame retention head (see figure 11) is used to swirl (cone) the fog-like oil and air mixture as it enters the combustion chamber. Three different heads are used in the O23/OHR23/OF23. The firing rate dictates which head is used. See table 4. The greater the FB number the larger the slots on the head. When combustion takes place, the flame will be cylindrical compact shaped as a result.

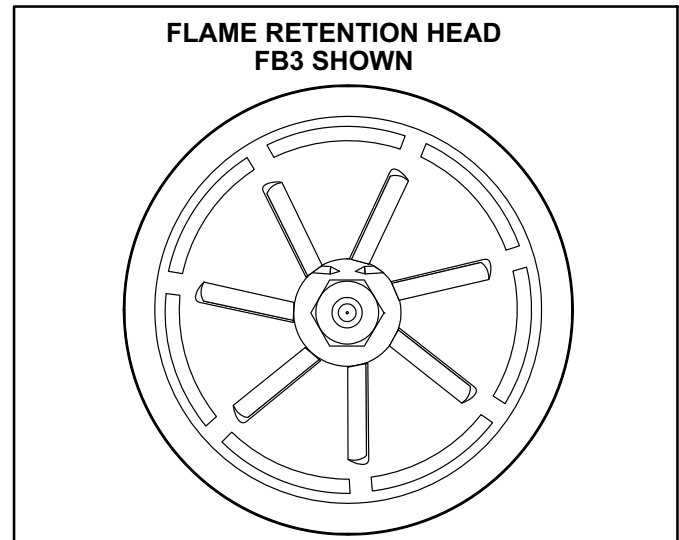

FIGURE 11

C-Primary Limit Control (S10)

The primary limit on all O23, OHR23, and OF23 units, is located on the vestibule panel (see figures 1 through 3 for location and figure 12 for type). When excess heat is sensed in the heat exchanger, the limit will open. If the limit is tripped, the blower control de-energizes the thermostat, in turn shutting down the unit. The limit automatically resets when unit temperature returns to normal. The switch is factory set and cannot be adjusted. The switch has a different setpoint for each unit model number (see table 7). The setpoint is printed on the face plate of the limit.

TABLE 7

PRIMARY LIMIT CONTROL (S10)		
UNIT	ACTUATES ON TEMP. RISE	ACTUATES ON TEMP. FALL
O23Q2-70	210°F (99°C)	180°F (82°C)
O23Q3-105/120	220°F (104°C)	190°F (88°C)
O23Q5-140/154	210°F (99°C)	180°F (82°C)
OHR23Q3-105/120	240°F (116°C)	210°F (99°C)
OHR23Q5-140/154	190°F (88°C)	160°F (71°C)
OF23Q3-105/120 OF23Q3-105/120R	240°F (116°C)	210°F (99°C)
OF23Q5-140/154 OF23Q5-140/154R	210°F (99°C)	180°F (82°C)

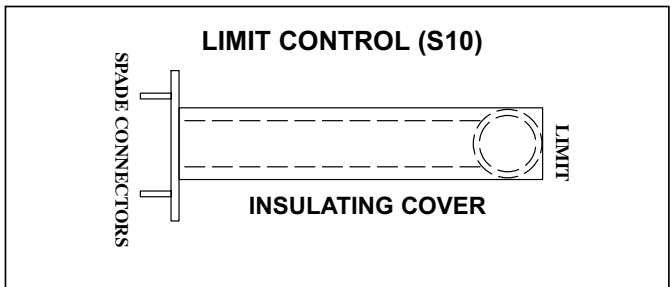

FIGURE 12

D-Blower Compartment (Figure 13)

Blower motor (B3), capacitor (C4), and secondary limit control (S21) are located in the blower compartment. The blower compartment can be accessed by removing the blower access panel.

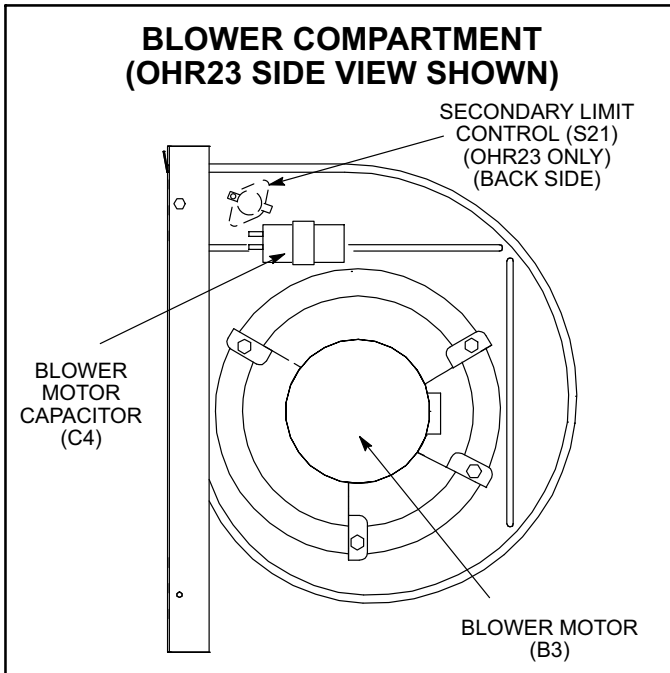

FIGURE 13

1. Blower Motor (B3) and Capacitor (C4)

All O23, OHR23, and OF23 series units use single phase direct drive blower motors. All motors used are 115V permanent split capacitor motors to ensure maximum efficiency. See SPECIFICATIONS tables for horsepower and motor nameplate for capacitor rating. The blower motor is connected to the blower control board via the blower motor plug P43.

2. Secondary Limit Control (S21)

The secondary limit (S21) is used on the OHR23 series unit only. The N.C. limit is mounted on the side and toward the back of the blower housing. See figure 13 for location and figure 14 for type. When excess heat is sensed in the blower compartment, the limit will open. If the limit is tripped, the blower control de-energizes the thermostat, inturn shutting down the unit. The limit automatically resets when unit temperature returns to normal. The switch opens at 150°F ± 5°F (65.5°C ± 2.8°C) on a temperature rise and resets at 140°F ± 5°F (60.0°C ± 2.8°C) on a temperature fall. The switch is factory set and cannot be adjusted. The set-point is printed on the face plate of the limit.

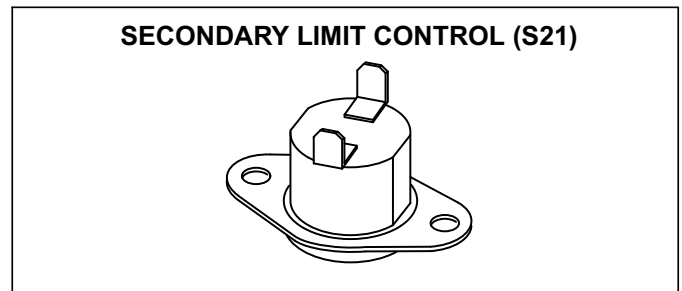

FIGURE 14

E-Optional Accessories

Optional accessories are available from Lennox for the O23, OHR23, and OF23 series units. Some accessories are in kit form which come with instructions.

1. Low Speed On - Off Switch (S68)

The low speed on - off switch is a kit (catalog # 67H91) which permits continuous low speed blower operation. The switch is a DPDT toggle switch.

2. Economizer Relay (K43)

The economizer relay (catalog # 65G40) is used to energize the economizer if used. The relay is a 120V coil, single pole contact which is energized by the accessory terminal of the blower control board.

II-PLACEMENT AND INSTALLATION

Make sure unit is installed in accordance with installation instructions and applicable codes.

A-Piping

The piping system and its components (oil filter, safety valves, shut-off valves, etc.) must be designed to provide clean, air free fuel to the burner.

An oil filter is required for all models. Use an oil filter of generous capacity for all installations. Install filter inside the building between the tank shut-off valve and the burner. Locate filter close to burner for easy servicing. The GAR-Ber 11BV-R or equivalent filter (with the below specifications) is recommended.

Maximum Firing Rate: 10GPH (38LPH)

Micron Removal: 10

Filtering Area: 500 in.² (3225.8 cm²)

Working Pressure: 15 PSI (103.4 kPa)

Inlet/Outlet Dimension: 3/8" (9.5 mm) NPT

Flow Rate: 45GPH (171LPH)

Care must be taken to ensure the restriction of the piping system, plus any lift involved, does not exceed the capability of the oil pump. Each installation will be different. Use the following guide lines when determining to use a single or two stage pump.

When using a single pipe system with the fuel supply level with or above the burner (see figure 15) and a vacuum of 6" (152 mm) Hg or below, a single stage fuel unit with a supply line and no return line should be adequate. Manual bleeding of the fuel unit is required on initial start up. Failure to bleed air from the pump could result in an air lock/oil starvation condition.

NOTE-As an extra precaution, cycle heating on and off ten times after bleeding air from the pump. This will eliminate air in the gun assembly.

When using a two pipe system with the fuel supply level below the level of the burner (see figure 16) a single stage fuel unit should be used in lift conditions of up to 10 feet (3 m) and/or a vacuum of 10" (254 mm) Hg or below. A two stage fuel unit should be used when lift exceeds 10 feet (3 m) and/or a vacuum of 10" (254 mm) Hg to 15" (381 mm) Hg. Both conditions require the use of a return line that purges the fuel unit of air by returning it to the fuel tank. Use table 8 when determining the run and lift for piping.

Before converting a one-pipe system to a two-pipe system the pump must be converted to a two-pipe system. To convert the pump, install the bypass plug according to the instructions. Notice in the two-pipe system the return line must terminate 3" (76 mm) to 4" (102 mm) above the supply inlet. Failure to do this may introduce air into the system and could result in loss of prime.

NOTE-If using an outside tank in cold climates a number one fuel or an oil treatment is strongly recommended.

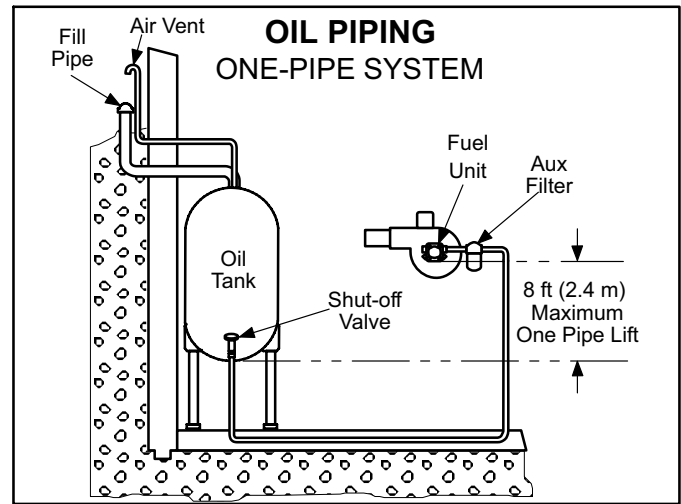
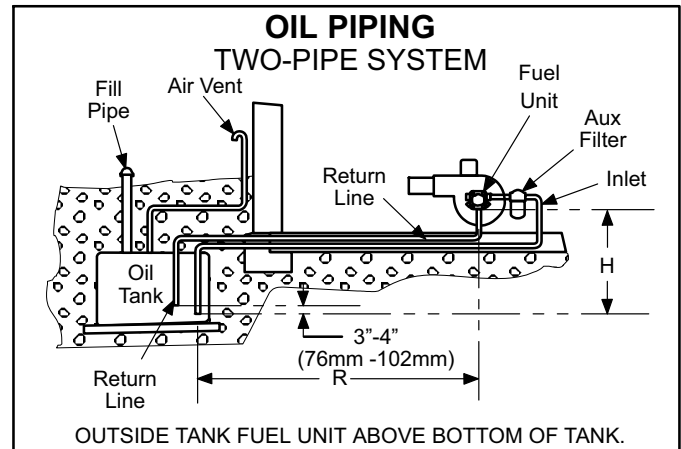

FIGURE 15



OUTSIDE TANK FUEL UNIT ABOVE BOTTOM OF TANK.

FIGURE 16

TABLE 8

TWO-PIPE MAXIMUM LINE LENGTH (H + R)				
Lift "H" Figure 15	3450 RPM - 3 GPH (11.4 LPH)			
	3/8" (10 mm) OD Tubing		1/2" (12 mm) OD Tubing	
	Single Stage	Two Stage	Single Stage	Two Stage
0' (0.0 m)	84' (25.6 m)	93' (28.3 m)	100' (30.5 m)	100' (30.5 m)
2' (0.6 m)	73' (22.3 m)	85' (25.9 m)	100' (30.5 m)	100' (30.5 m)
4' (1.2m)	63' (19.2 m)	77' (23.5 m)	100' (30.5 m)	100' (30.5 m)
6' (1.8m)	52' (15.8 m)	69' (21.0 m)	100' (30.5 m)	100' (30.5 m)
8' (2.4m)	42' (12.8 m)	60' (18.3 m)	100' (30.5 m)	100' (30.5 m)
10' (3.0m)	31' (9.4 m)	52' (15.9 m)	100' (30.5 m)	100' (30.5 m)
12' (3.7m)	21' (6.4 m)	44' (13.4 m)	83' (25.3 m)	100' (30.5 m)
14' (4.3m)	---	36' (11.0 m)	41' (12.5 m)	100' (30.5 m)
16' (4.9m)	---	27' (8.2 m)	---	100' (30.5 m)
18' (5.5m)	---	---	---	76' (23.2 m)

B-Venting Considerations

⚠ WARNING

Combustion air openings in front of the furnace must be kept free of obstructions. Any obstruction will cause improper burner operation and may result in a fire hazard or injury.

⚠ WARNING

The barometric shall be in the same atmospheric pressure zone as the combustion air inlet to the furnace. Deviation from this practice will cause improper burner operation and may result in a fire hazard or injury.

⚠ CAUTION

Do not store combustible materials near the furnace or supply air ducts. The material (such as paint, motor oil, gasoline, paint thinner, etc.) may ignite by spontaneous combustion creating a fire hazard.

⚠ WARNING

This furnace is certified for use with type "L" vent. "B" vent must not be used with oil furnaces.

NOTE-Oil burning equipment may be vented into an approved masonry chimney or type L vent. (Type L vent is similar in construction to type B gas vent except it carries a higher temperature rating and is constructed with an inner liner of stainless steel rather than aluminum).

Prior to installation of unit, make a thorough inspection of the chimney to determine whether repairs are necessary. Make sure the chimney is properly constructed and sized according to the requirements of the National Fire Protection Association. The smallest dimensions of the chimney should be at least equal to the diameter of the furnace vent connector. Make sure the chimney will produce a steady draft sufficient to remove all the products of combustion from the furnace. A draft of at least .04" w.c. (9.9 Pa) is required during burner operation.

- 1- Local building codes may have more stringent installation requirements and should be consulted before installation of unit.

- 2- The vent connector should be as short as possible to do the job.
- 3- The vent connector should not be smaller than the outlet diameter of the vent outlet of the furnace.
- 4- Pipe should be at least 24 gauge galvanized.
- 5- Single wall vent pipe should not run outside or through any unconditioned space.
- 6- Chimney should extend 3 feet (0.9 m) above the highest point where the vent passes through the roof, and 2 feet (0.6 m) higher than any portion of a building within a horizontal distance of 10 feet (3 m).
- 7- The vent must not pass through a floor or ceiling. Clearances to single wall vent pipe should be no less than 6" (152 mm); more if local codes require it.
- 8- The vent may pass through a wall where provisions have been made for a thimble as specified in the Standards of the National Board of Fire Underwriters. See figure 17.
- 9- The vent pipe should slope upward toward the chimney on horizontal run at least 1/4 inch (6 mm) to the foot (0.3 m) and should be supported by something other than the furnace, such as isolation hangers. See figure 18.
- 10- Extend the vent pipe into the chimney so that it is flush with the inside of the vent liner. Seal the joint between the pipe and the liner.
- 11- The furnace shall be connected to a factory built chimney or vent complying with a recognized standard, or masonry or concrete chimney lined with a lining material acceptable to the authority having jurisdiction.

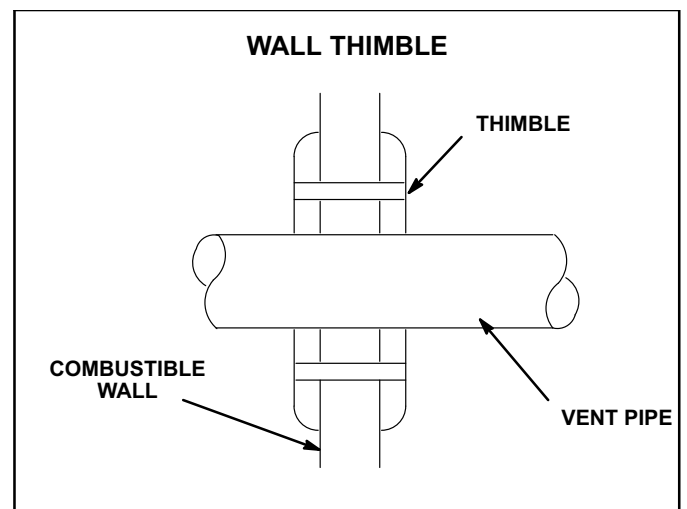

FIGURE 17

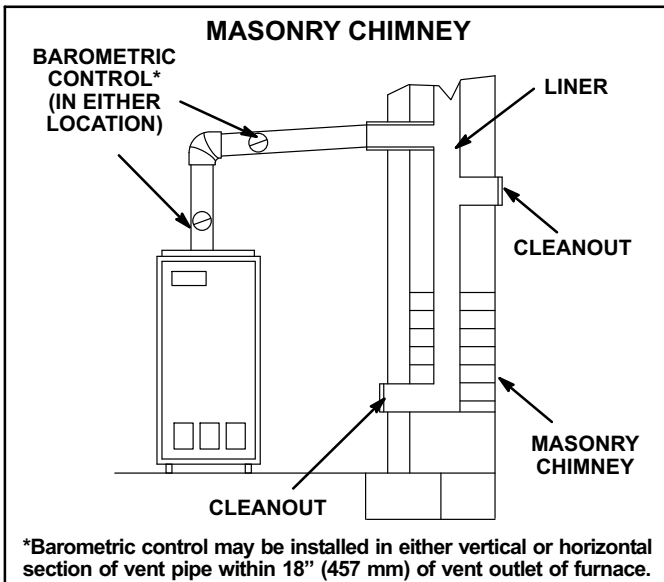

FIGURE 18

- 12- When two or more appliances vent into a common vent, the area of the common vent should not be less than the area of the largest vent or vent connection plus 50% of the areas of the additional vent or vent connection. Chimney must be able to sufficiently vent all appliances operating at the same time.
- 13- The vent pipe shall not be connected to a chimney vent serving a solid fuel appliance or any mechanical draft system.
- 14- All unused chimney openings should be closed.
- 15- All vent pipe run through unconditioned areas or outside shall be constructed of factory built chimney sections. See figure 19.
- 16- Where condensation of vent gas is apparent, the vent should be repaired or replaced. Accumulation of condensation in the vent is unacceptable.

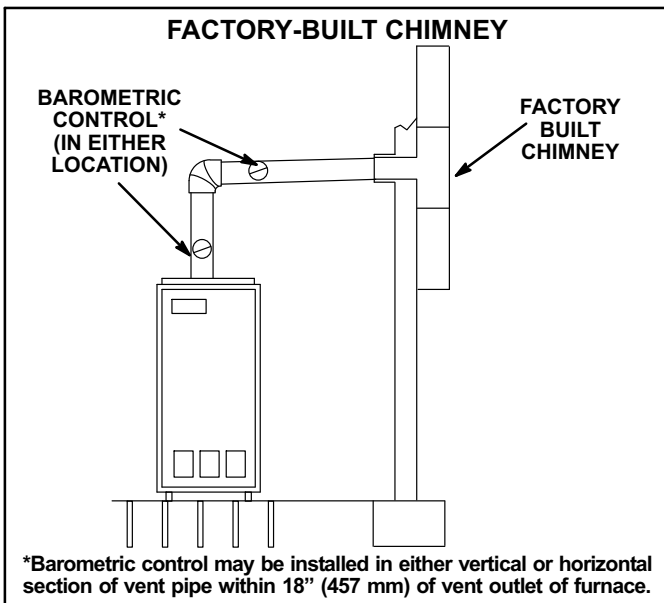

FIGURE 19

- 17- Vent connectors serving this appliance shall not be connected into any portion of mechanical draft systems operating under positive pressure.
- 18- Keep the area around the vent terminal free of snow, ice and debris.

NOTE-If vent pipe needs to exit from side of cabinet, use the cross hairs (located on either side of the unit) to cut a 6" (152 mm) round hole. Attach finishing plate (provided) with four sheet metal screws to cover rough edges.

Combustion and Ventilation Air (Confined and Unconfined Spaces)

Until recently, there was no problem in bringing in sufficient amounts of outdoor air for combustion -- infiltration provided all the air that was needed and then some. In today's homes built with energy conservation in mind, tight construction practices make it necessary to bring in air from outside for combustion. Consideration must also be given to the use of exhaust fans, appliance vents, chimneys and fireplaces because they force additional air that could be used for combustion out of the house. Unless outside air is brought into the home for combustion, negative pressure (pressure outside is greater than inside pressure) will build to the point that a down draft can occur in the furnace vent pipe or chimney. Combustion gases enter the living space creating a potentially dangerous situation.

The importance of the previous paragraph cannot be overstated. Users may inadvertently block fresh air intakes after installation.

In the absence of local codes concerning air for combustion and ventilation, the following section outlines guidelines and recommends procedures for operating oil furnaces in a manner that ensures efficient and safe operation. Special consideration must be given to combustion air needs as well as requirements for exhaust vents and oil piping.

Combustion Air Requirements

⚠ CAUTION

Insufficient combustion air can cause headaches, nausea, dizziness or asphyxiation. It will also cause excess water in the heat exchanger resulting in rusting and premature heat exchanger failure. It can also cause property damage.

All oil-fired appliances require air to be used for the combustion process. If sufficient amounts of combustion air are not available, the furnace or other appliance will operate in an inefficient and unsafe manner. Enough air must be provided to meet the needs of all fuel-burning appliances, as well as appliances such as exhaust fans which force air out of the home. When fireplaces, exhaust fans, or clothes dryers are used at the same time as the furnace, much more air is required to ensure proper combustion and to prevent a down-draft situation. Insufficient amounts of air also cause in-

complete combustion which can result in sooting. Requirements for providing air for combustion and ventilation depend largely on whether the furnace is installed in an unconfined or confined space.

Unconfined Space

An unconfined space is an area such as a basement or large equipment room with a volume greater than 50 cubic feet (1.4 cubic meters) per 1,000 Btu (293 W) per hour of the combined input rating of all appliances installed in that space. This space also includes adjacent rooms which are not separated by a door. Though an area may appear to be unconfined, it might be necessary to bring in outdoor air for combustion if the structure does not provide enough air by infiltration. If the furnace is located in a building of tight construction with weather stripping and caulking around the windows and doors, follow the procedures outlined for using air from the outside for combustion and ventilation.

Confined Space

A confined space is an area with volume less than 50 cubic feet (1.4 cubic meters) per 1,000 Btu (293 W) per hour of the combined input rating of all appliances installed in that space. This definition includes furnace closets or small equipment rooms.

When the furnace is installed so that supply ducts carry air circulated by the furnace to areas outside the space containing the furnace, the return air must be handled by ducts which are sealed to the furnace casing and which terminate outside the space containing the furnace. This is especially important when the furnace is mounted on a platform in a confined space such as a closet or small equipment room. Even a small leak around the base of the unit at the platform or at the return air duct connection can cause a potentially dangerous negative pressure condition. Air for combustion and ventilation can be brought into the confined space either from inside the building or from outside.

Air from an Adjacent Space

If the confined space housing the furnace adjoins space categorized as unconfined, air can be brought in by providing two permanent openings between the two spaces. Each opening must have a minimum free area of 1 square inch (6.4 square centimeters) per 1,000 Btu (293 W) per hour of the total input rating of all fuel-fired equipment in the confined space. Each opening must be at least 100 square inches (614.5 square centimeters). One opening shall be within 12" (305 mm) of the top of the enclosure and one opening within 12" (305 mm) of the bottom (See figure 20).

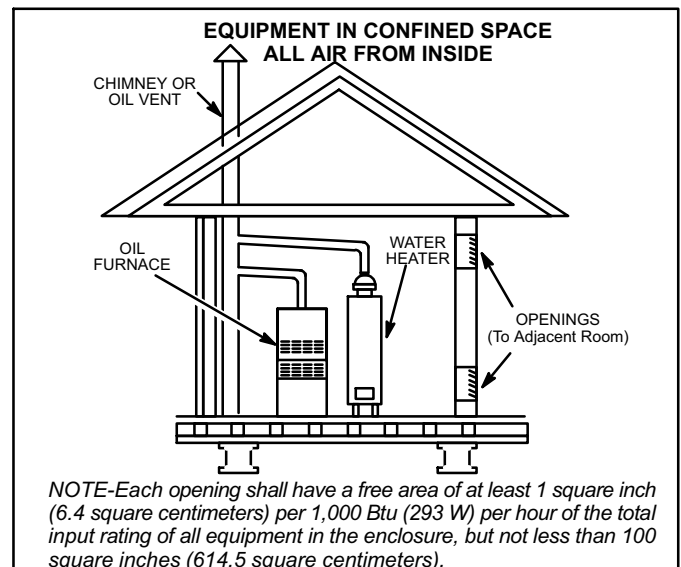

FIGURE 20

Air from Outside

If air from outside is brought in for combustion and ventilation, the confined space shall be provided with two permanent openings. One opening shall be within 12" (305 mm) of the top of the enclosure and one within 12" (305 mm) of the bottom. These openings must communicate directly or by ducts with the outdoors or spaces (crawl or attic) that freely communicate with the outdoors or indirectly through vertical ducts. Each opening shall have a minimum free area of 1 square inch (6.4 square centimeters) per 4,000 Btu (1172 W) per hour of total input rating of all equipment in the enclosure (See figures 21 and 22). When communicating with the outdoors through horizontal ducts, each opening shall have a minimum free area of 1 square inch (6.4 square centimeters) per 2,000 Btu (586 W) per total input rating of all equipment in the enclosure (See figure 23).

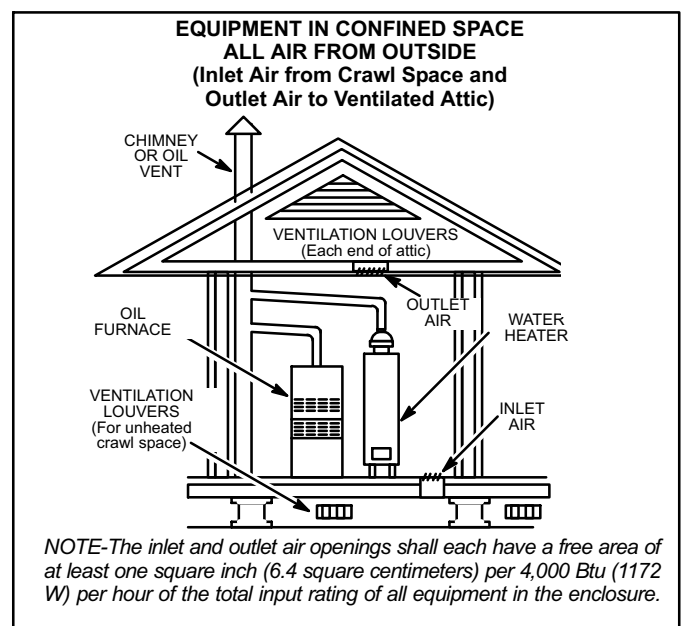

FIGURE 21

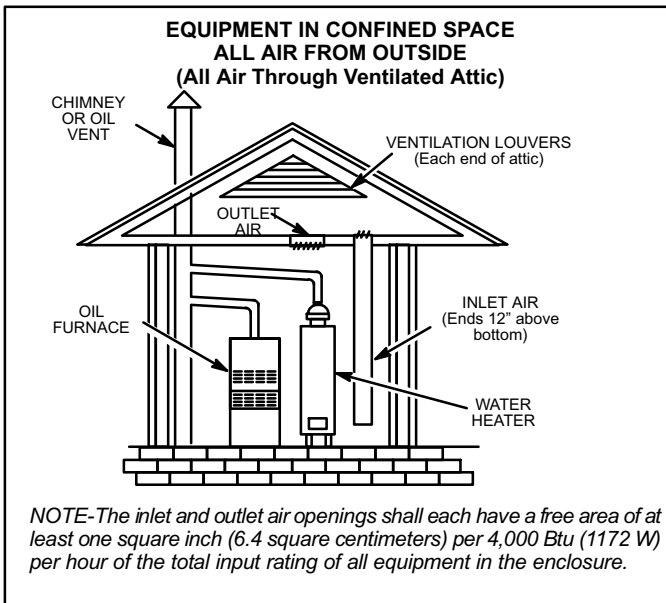

FIGURE 22

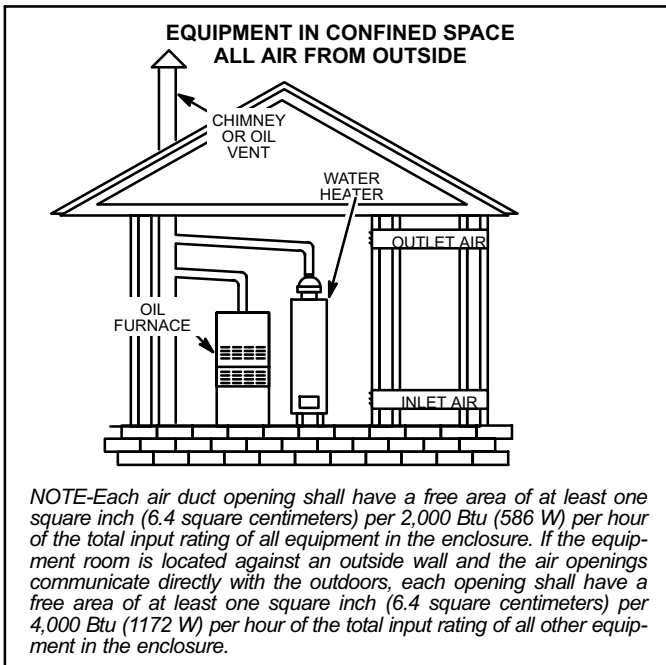

FIGURE 23

When ducts are used, they shall be of the same cross-sectional area as the free area of the openings to which they connect. The minimum dimension of rectangular air ducts shall be no less than 3" (76 mm). In calculating free area, the blocking effect of louvers, grilles, or screens must be considered. If the design and free area of protective covering is not known for calculating the size opening required, it may be assumed that wood louvers will have 20 to 25 percent free area and metal louvers and grilles will have 60 to 75 percent free area. Louvers and grilles must be fixed in the open position or interlocked with the equipment so that they are opened automatically during equipment operation.

⚠ CAUTION

Combustion air openings in the front of the furnace must be kept free of obstructions. Any obstruction will cause improper burner operation and may result in a fire hazard or injury.

⚠ CAUTION

The barometric shall be in the same atmospheric pressure zone as the combustion air inlet to the furnace. Deviation from this practice will cause improper burner operation and may result in a fire hazard or injury.

Direct Connection of Outdoor Air for Combustion

The Beckett AFII burner was designed to allow for direct air intake piping (4" [102 mm]). The maximum equivalent length of pipe is 70 feet (21.3 m). A 90° elbow equals 6feet (1.8 m).

To convert the AFII burner from confined space to outside combustion air, simply remove the three screws attaching the inlet air scoop to the burner and insert 4" (102 mm) direct air intake piping.

The use of a barometric relief placed in the intake pipe is recommended when outdoor combustion air is directly connected to the burner. This will allow confined space air to be used as combustion air in the event that the opening to the outdoor air becomes blocked. Using a barometric relief in the intake will reduce the chance of sooting.

⚠ CAUTION

DO NOT USE a barometric draft relief in exhaust vent pipe if outdoor combustion air is connected directly to the burner. The only exception are barometric draft reliefs as required by FIELD or TJERN-LUND power vents.

Removal of Unit from Common Venting System

In the event that an existing furnace is removed from a venting system commonly run with separate appliances, the venting system is likely to be too large to properly vent the remaining attached appliances. The following test should be conducted while each appliance is in operation and the other appliances not in operation remain connected to the common venting system. If venting system has been installed improperly, the system must be corrected as outlined in the previous section.

- 1- Seal any unused openings in the common venting system.
- 2- Visually inspect venting system for proper size and horizontal pitch and determine there is no blockage or restriction, leakage, corrosion or other deficiencies which could cause an unsafe condition.

- 3- Insofar as is practical, close all building doors and windows and all doors between the space in which the appliances remaining connected to the common venting system are located and other spaces of the building. Turn on clothes dryers and any appliances not connected to the common venting system. Turn on any exhaust fans, such as range hoods and bathroom exhausts, so they will operate at maximum speed. Do not operate a summer exhaust fan. Close fireplace dampers.
- 4- Following the lighting instruction on the unit, place the appliance being inspected in operation. Adjust thermostat so appliance will operate continuously.
- 5- Test for spillage using a draft gauge.
- 6- After it has been determined that each appliance remaining connected to the common venting system properly vents when tested as outlined above, return doors, windows, exhaust fans, fireplace dampers and any other fuel burning appliance to their previous condition of use.
- 7- If improper venting is observed during any of the above tests, the common venting system must be corrected.

Horizontal Venting

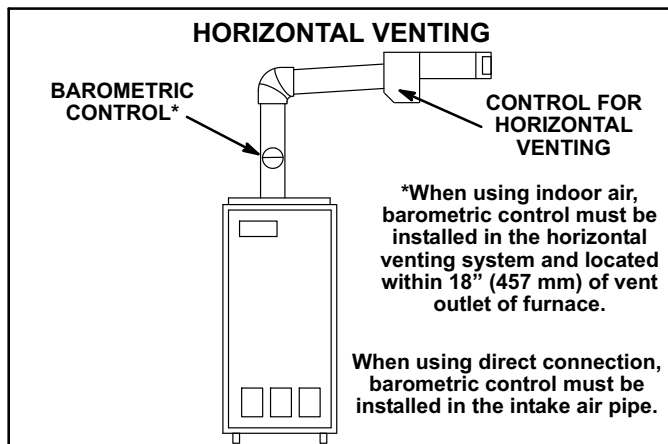

FIGURE 24

The O23 is approved for horizontal venting with the following mechanical vent systems:

Tjernlund (sideshot) #SS1C and Field Controls #SWG-5 with the CK-61 control kit. Refer to manufacturers' installation instructions for proper installation procedures and service parts information.

Do not common vent with any other appliance when using sidewall vent system.

Maximum permissible vent length is 70 equivalent feet (21.3 m). Minimum length is 15 equivalent feet (4.6 m). Each 90° elbow is equal to 6 feet (1.8 m) of straight pipe, each 45° elbow is equal to 3 feet (0.9 m) of straight pipe. Minimum vent pipe diameter is 4" (102 mm). Vent pipe of 5" (127 mm) and 6"

(152 mm) is permissible. Calculate the equivalent vent pipe footage from the furnace to the mechanical vent system (Tjernlund or Field Controls) by adding the straight vent pipe length and the equivalent elbow lengths together.

The barometric draft control must be used in horizontal (sidewall) venting system. It must be located within 18" (457 mm) of the furnace vent outlet. See figure 24 for barometric draft control location.

III-START-UP

A-Preliminary and Seasonal Checks

- 1- Inspect electrical wiring, both field and factory installed for loose connections. Tighten as required.
- 2- Check line voltage. Voltage must be within range listed on the nameplate. If not, consult the power company and have voltage condition corrected before starting unit.

B-Heating Start-Up

FOR YOUR SAFETY READ BEFORE LIGHTING

⚠ WARNING

Do not attempt to start the burner when excess oil has accumulated in the chamber, when the furnace is full of vapor or when the combustion chamber is very hot.

- 1- Set thermostat for heating demand.
- 2- Turn on electrical supply to unit and open all shut-off valves in the oil supply line to the burner.
- 3- Check air adjustment dial on the right side of the burner (see figure 9). Set according to table 4.
- 4- On single line applications the oil pump must be primed by bleeding the oil line. Open air bleed port and start burner. A hose may be attached to direct oil into a container. After last bubble is seen, bleed pump for 15 seconds. Hurried bleeding will impair efficient unit operation. Close port to stop bleeding. Single line installations must be absolutely air tight to prevent leaks or loss of prime.
- 5- If burner stops after flame is established, repeat the bleeding procedure.

NOTE-Air bleeding is automatic on two line applications; however, opening air bleed port will allow a faster bleed. Run return line back to tank and terminate three to four inches above the inlet line. Failure to bleed the system may cause air to be introduced into the system resulting in a loss of prime.

- 6- If the burner does not start immediately, check the safety switch on the burner primary control.
- 7- If burner fails to light again, refer to the troubleshooting section in the back of this manual.
- 8- Proceed to section IV to complete start up.

C-Safety or Emergency Shutdown

Turn off unit power. Close all shut-off valves in the oil supply line.

D-Extended Period Shutdown

Turn off thermostat or set to “UNOCCUPIED” mode. Close **all** shut-off valves in the oil supply line to guarantee no oil leaks into burner. Turn off all power to unit. All access panels, covers and vent caps must be in place and secured.

IV-HEATING SYSTEM SERVICE CHECKS

A-Oil Piping

All oil supply piping (factory and field) must be carefully checked for oil leaks.

B-Electrode Adjustment

When adjusting the electrode, use the AFII multipurpose gauge (Beckett part# T-500) packaged with each oil furnace, also available from Beckett.

To set the electrode tip gap spacing, position the gauge as shown in figure 25. Align the center mark with the nozzle and adjust the electrodes to the two outer marks (1/8” [3mm] to 1/16” [2mm] minimum).

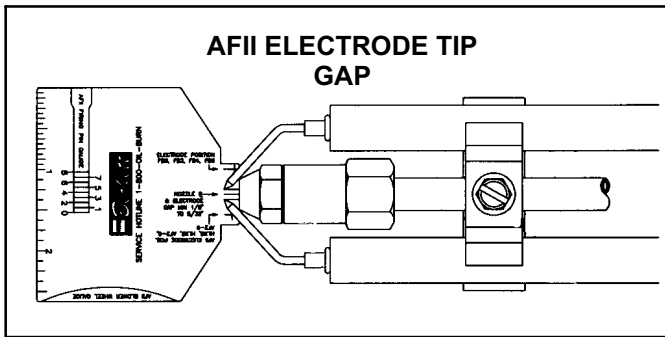

FIGURE 25

To position the electrode tips beyond the face of the nozzle and above the center line, position the gauge as shown in figure 26. Align the center mark with the nozzle and adjust the electrodes to the **AC cross marks**.

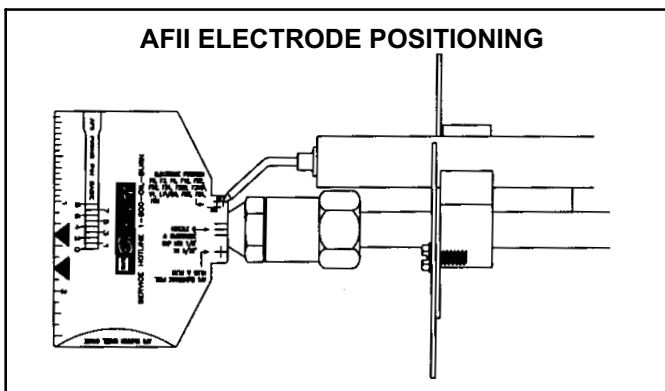

FIGURE 26

To check that the nozzle is approximately centered with the head inside diameter, align the center mark of the gauge with the center of the nozzle orifice, as shown in figure 27, and move the gauge from side to side at several points. **Be careful not to scratch the nozzle surface.**

The “Z” or zero dimension is important because it locates the nozzle for the precise relationship with the combustion head. To set the “Z” dimension, position the gauge as shown in figure 27 and loosen the nozzle line electrode assembly so that it can be moved forward or backward in the air tube until the nozzle becomes flush against the gauge. Tighten the nozzle line escutcheon plate screw (shown in figure 9) to lock this “Z” dimension securely.

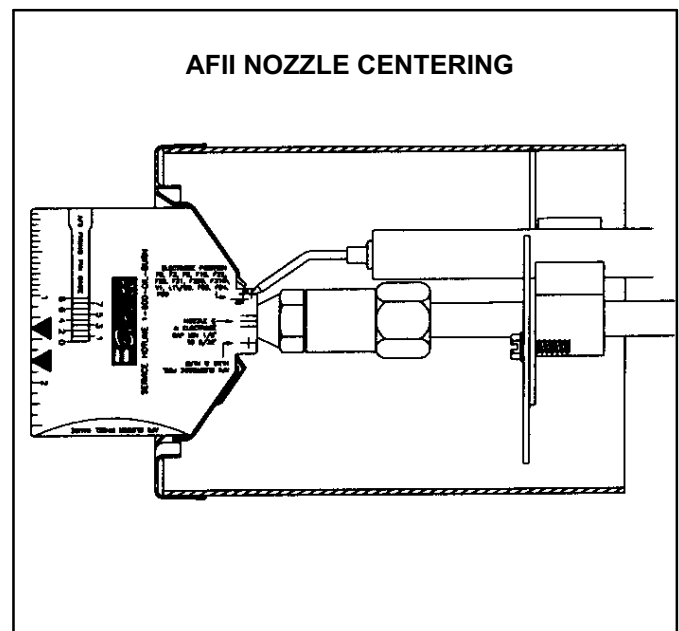

FIGURE 27

C-Pressure Check

On -1 through -4 units use either the gauge port or nozzle port to check operating pressure. On -5 units use the nozzle port (-5 unit pumps are not equipped with gauge port). The pump is factory set at **100 psig (689.5 kPa)** for the O23Q2-70 and **140 psig (965.3 kPa)** for all other O23, OHR23, and OF23 units but is adjustable (see figure 28). Never operate the pump in excess of 10 psig (69 kPa) above set point. Average nozzle cutoff pressure is 80 psig (551.6 kPa). To check the cutoff pressure install a pressure gauge in nozzle port. For -5 units use the same gauge used for operating pressure. Run the burn-

er for a short period and then turn off. The gauge shows cutoff pressure.

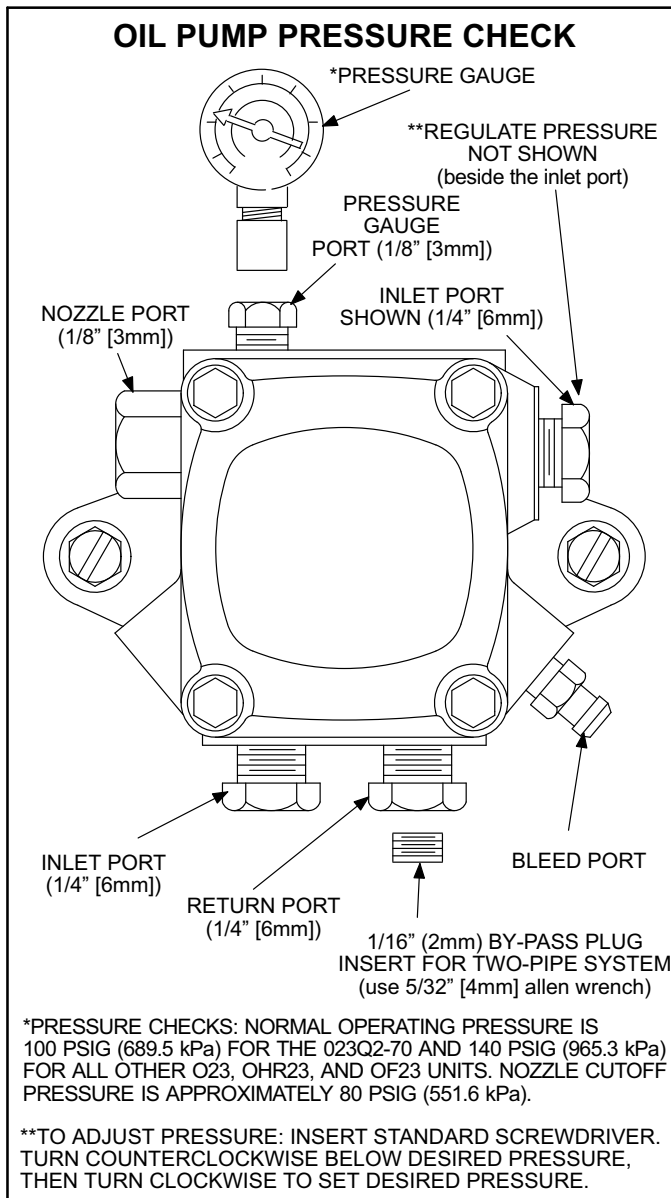

FIGURE 28

D-Burner Adjustment

The following instructions are essential to the proper operation of O23 series oil furnaces. To prevent sooting, these instructions must be followed in sequence:

NOTE-All w.c. measurements are below atmospheric pressure (negative readings).

1-Draft

This test should be taken at the vent connector between the breaching and the barometric damper. Generally a 1/4" (6 mm) hole will need to be drilled for the draft gauge to be inserted into the vent connector.

A minimum of 0.03" w.c. (7.5 Pa) draft must be established without the burner in operation. With the burner in operation, the draft should be 0.04" w.c. (9.9 Pa) to 0.05" w.c. (12.4 Pa). This is VERY critical to the flame retention head burners.

Oil furnace installations also require careful inspection to make sure the chimney is in good condition and can accommodate the products of combustion. The temperature in unconditioned space will also affect the draft if long vent connectors are allowed to get too cold.

2-Overfire Draft

This test should be taken with the burner in operation. Remove the screw from the center of the center inspection port. Insert your draft gauge into the hole.

A reading of the overfire draft should be 0.02" w.c. (5.0 Pa) less than the reading found in the vent connector. If a positive reading is seen at this point, the secondary heat exchanger may be sooted or too much air may be entering into the heat exchanger from the combustion fan. Adjustments to the combustion fan can be made using the air adjustment dial.

3-Smoke Test

The smoke test should be taken at hole drilled in step 1.

Using a smoke test gun adjust the air inlet shutter so that you will have just a trace of smoke. Somewhere between a 0 and #1 smoke. This is the *starting* point. Do not stop here. After the smoke test take a CO sample. C.S.A. requires no more than 400ppm. However, a properly installed unit under normal operating conditions should not read more than 50ppm.

4-CO₂ Test

Again to be taken at the vent connector pipe. With the unit firing at a trace of smoke, test for percentage of CO₂ in the vent gas.

From the results of this test, a "window of operation" will be determined. This window of operation establishes some tolerance. The tolerance the installer builds in provides room within the set-up for those things which might affect combustion. Those things which might affect combustion can then do so without causing the unit to start sooting/smoking. Things which might affect combustion include a nozzle going bad, draft that changes during different climatic conditions, dirty oil, dirt obstructing the air inlet, etc.

To build in a "window of operation," set up the burner to be 2% less in CO₂. For example, if you find a reading of 12% CO₂, adjust the air inlet shutter to increase the air and drop the CO₂ to 10%.

5-Retest the Smoke

With a drop in the CO₂ and increase in the air you should see that the smoke has returned to 0.

6-Retest the Overfire Draft

This test serves to confirm that you have not increased the air too much. Again you do not want a positive pressure at the test port. It should still be 0.02" w.c. (5.0 Pa) less than the draft from the vent connector. You may need to increase the stack draft by adjusting the barometric damper.

7-Stack Temperature

Take a stack temperature reading in the vent connector pipe. Subtract the room air temperature from the stack temperature. This will give you the net stack temperature. Using efficiency charts provided in most CO₂ analyzers you can tell at what efficiency the furnace is operating.

V-DISASSEMBLY PROCEDURES

Use the following procedures to access and disassemble the burner or blower if service to either is needed.

⚠ WARNING	
	Electric shock hazard. Can cause injury or death. Before attempting to perform any service or maintenance, turn the electrical power to unit OFF at disconnect switch(es). Unit may have multiple power supplies.

A-Disassembling Burner

The burner assembly is attached to the vestibule panel by three nuts. Slots are provided in the mounting flange for removing the burner assembly from the vestibule. By loosening the nuts and by turning the whole burner assembly counterclockwise (figure 29), the entire burner assembly will come out of the furnace. There is adequate wire to remove the burner without disconnecting wires. Once removed, just turn the burner around in the vest panel area.

NOTE-Before disassembling any part of the burner, turn off power and oil supply to the burner.

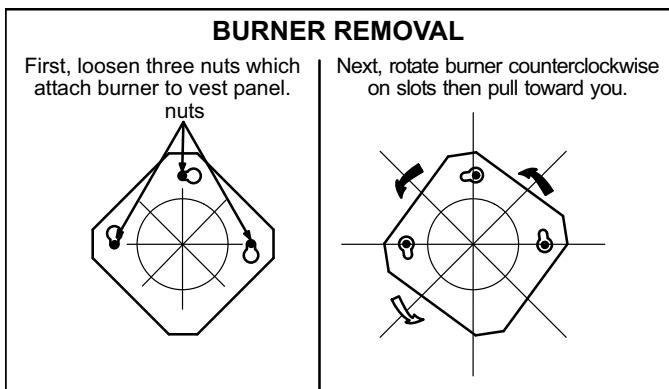

FIGURE 29

1-Removing Ignition Transformer

- 1- Remove all four screws located on the side of the ignition transformer. See figure 30.
- 2- **Lift the ignition transformer straight up.** Do not hinge back. Porcelain isolators may break if hinged back.

NOTE-When testing the solid state transformer, do not use a transformer tester designed for iron magnet transformers. Damage to the tester may result

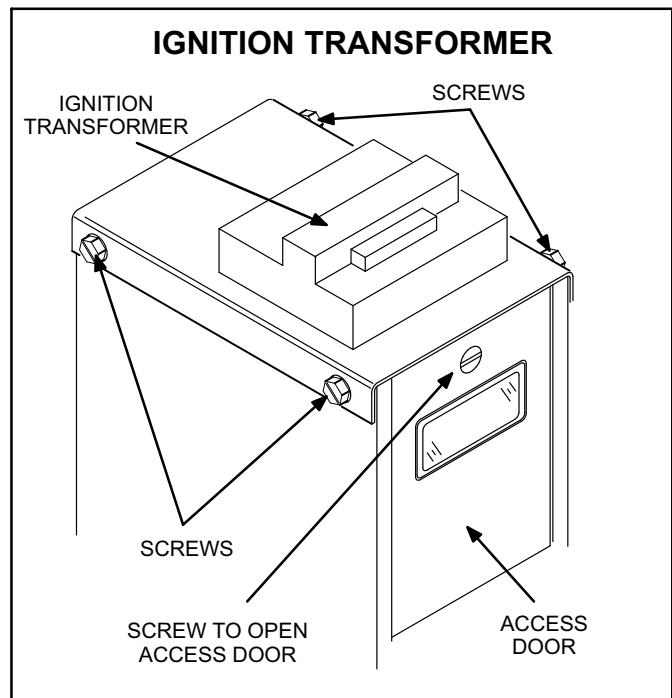

FIGURE 30

2-Removing Cad Cell

- 1- Loosen the screw to the back access door until door opens. See figures 30 and 31.
- 2- The cad cell will be located on the right side of the chassis wall hung on a bracket. See figure 31.
- 3- Remove by loosening the screw on the bracket.
- 4- Disconnect the leads from the primary control terminal strip.

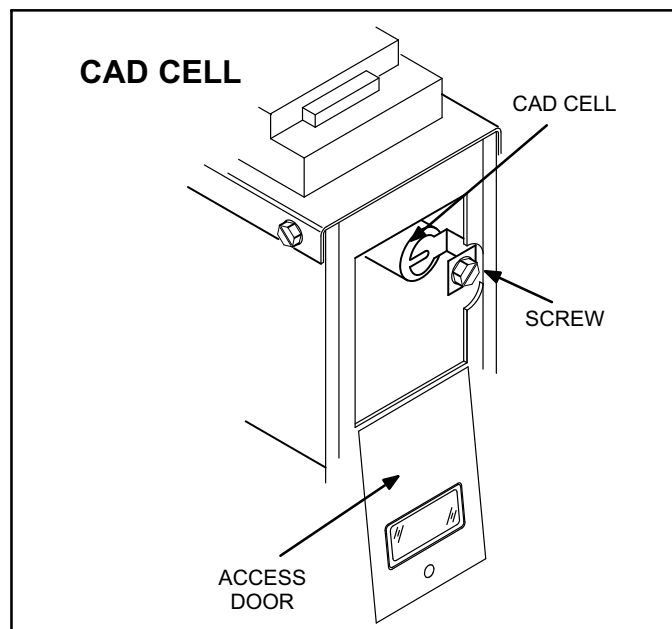

FIGURE 31

3-Removing Gun Assembly

- 1- Loosen the screw to the back access door until door opens. See figures 30 and 31.
- 2- Remove flare fitting nut on oil line at pipe adjusting plate located on outside of blower housing.
- 3- Remove nut connecting oil line to gun assembly oil line. See figure 32.
- 4- Remove gun assembly from air tube.
- 5- Remove transformer leads.

NOTE-When reinstalling gun assembly, check and set position and "Z" dimension as shown in figure 27.

NOTE-When reconnecting gun assembly oil line, make sure flat side of nut goes first.

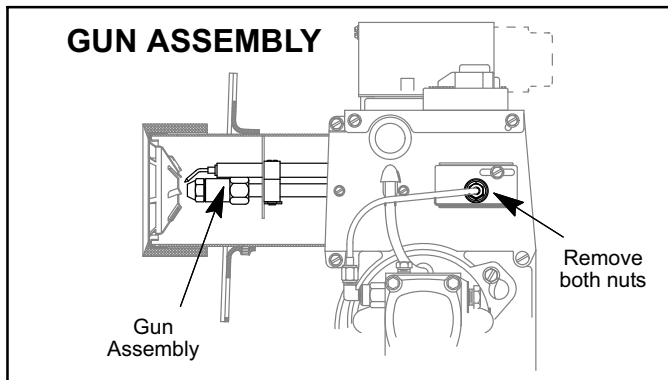

FIGURE 32

4-Removing Oil Pump

- 1- Disconnect supply line at pump and oil line at gun assembly.
- 2- Loosen two bolts on sides of pump securing pump to blower housing. See figure 33.
- 3- Detach pump and motor shaft coupler from pump.

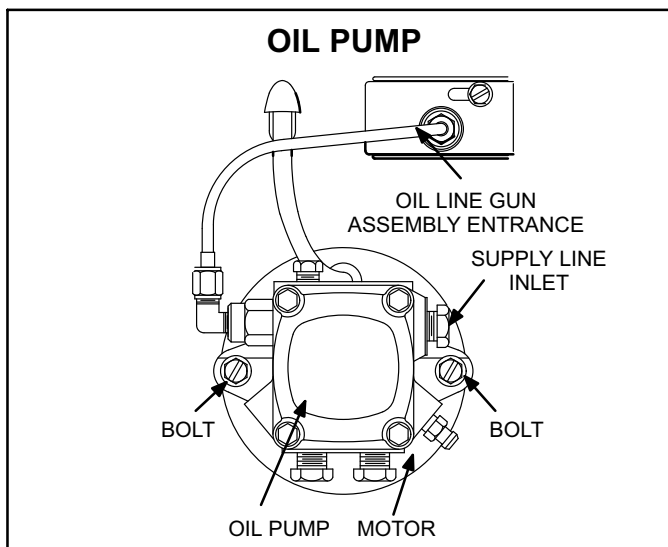

FIGURE 33

5-Removing Motor / Combustion Air Blower

- 1- Disconnect supply line at pump and oil line at gun assembly as shown in figure 33.
- 2- If motor and blower wheel are to be removed away from the burner, disconnect motor wiring harness from the primary control. If the motor and blower wheel only need to be removed to check and clean, there is adequate wire in the motor wiring harness without disconnecting.
- 3- Loosen two bolts securing motor to blower housing. Key hole slots are provided for easy removal. See figure 34.
- 4- Loosen allen set screw holding the blower wheel onto the motor shaft and remove blower wheel.

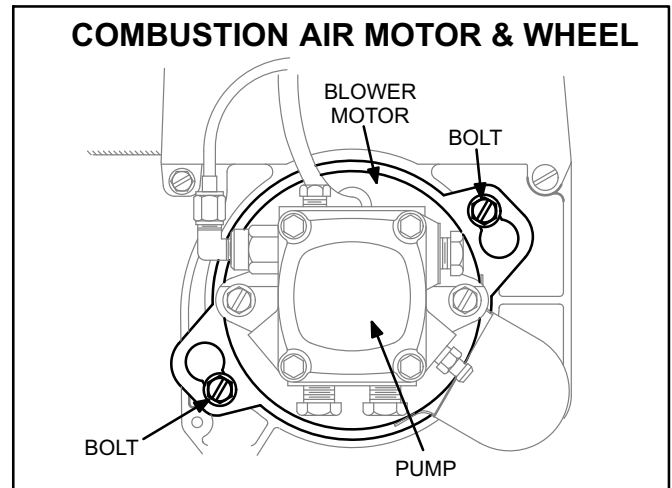

FIGURE 34

NOTE-When reinstalling blower wheel use the AFII multipurpose gauge (Beckett part # T-500) to space the distance from the back of the blower wheel to the face of the motor (1/16" [2 mm]).

B-Removing Indoor Blower

- 1- Turn off electric power to furnace.
- 2- Remove blower access door.
- 3- Remove two screws located in the front blower rails. See figure 35.
- 4- Pull blower forward enough to disconnect the motor leads and the secondary limit on OHR units.
- 5- Pull blower assembly out and place to the side.

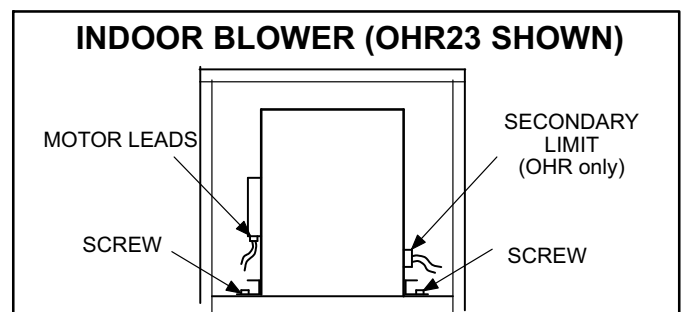

FIGURE 35

VI-TYPICAL OPERATING CHARACTERISTICS

A-Blower Operation and Adjustment

NOTE- The following is a generalized procedure and does not apply to all thermostat controls.

- 1- Blower operation is dependent on thermostat control system.
- 2- Generally, blower operation is set at thermostat sub-base fan switch. With fan switch in ON position, blower operates continuously. With fan switch in AUTO position, blower cycles with demand.
- 3- In all cases, blower and entire unit will be off when line voltage is disconnected.

B-Temperature Rise

Temperature rise for O23, OHR23, and OF23 units depends on unit input, blower speed, blower horsepower and static pressure. The blower speed must be set for unit operation within the range of "AIR TEMP. RISE °F" listed on the unit rating plate.

To Measure Temperature Rise:

1. Place plenum thermometers in the supply and return air plenums. Locate supply air thermometer in the first horizontal run of the plenum where it will not pick up radiant heat from the heat exchanger.
2. Set thermostat to highest setting.
3. After plenum thermometers have reached their highest and steadiest readings, subtract the two readings. The difference should be in the range listed on the unit rating plate. If the temperature is too low, decrease blower speed. If temperature is too high increase blower speed to reduce temperature. To change blower speed see Blower Speed section.

C-Blower Speed

Blower speed selection is accomplished by changing the wires at the blower motor spade connector.

To Change Blower Speed

- 1- Turn off electric power to furnace.
- 2- Remove blower access door.
- 3- Remove two screws located in the front blower rails.
- 4- Pull blower assembly forward enough to disconnect the motor leads.
- 5- Disconnect heating (red) and / or Cooling (black) wire(s) from the motor. The common (white) wire always remains on C = common.

- 6- Select the desired speed for heating and cooling (H = high, M = medium, L = Low). Table 9 lists the factory connections.
- 7- If cooling and heating speeds are to be the same speed, disconnect and discard the cooling wire. Jumper the A and H spade terminals on the BCC2 and BCC3 board and jumper COOL to HEAT on the ST9103A board. Run the heating terminal wire from the BCC2, BCC3 and ST9103A board to the correct spade connection on the blower motor.
- 8- To achieve low speed on continuous blower on the ST9103A board, run a FIELD supplied wire (16 AWG or larger) from blower motor low speed terminal to the ST9103A CONT terminal.

**TABLE 9
BLOWER SPEED SELECTION**

Unit	Factory Connected Speed Taps		Speeds Available
	Cool (Black)	Heat (Red)	
Q2-70	M	L	3
Q3-105/120	H	M	3
Q5-140/154	H	M	3

D-External Static Pressure

1. Measure tap locations as shown in figure 36.

2. Punch a 1/4" (6 mm) diameter hole in supply and return air plenums. Insert manometer hose flush with inside edge of hole or insulation. Seal around the hose with permagum. Connect the zero end of the manometer to the discharge (supply) side of the system. On ducted systems, connect the other end of manometer to the return duct as above. For systems with non-ducted returns, leave the other end of the manometer open to the atmosphere.

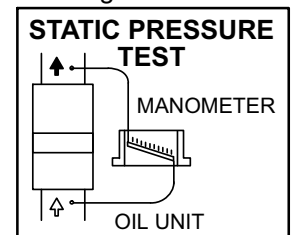

FIGURE 36

3. With only the blower motor running and the evaporator coil dry, observe the manometer reading. Adjust blower motor speed to deliver the air desired according to the job requirements.
4. Pressure drop must not exceed 0.5" W.C. (124.3 Pa).
5. Seal around the hole when the check is complete.

VII-MAINTENANCE

CAUTION

Never operate unit with access panels to the blower compartment off or partially open.

A-Filters

If throw-away type filters are used, check monthly and replace when necessary to assure proper furnace operation. Replace filters with like kind and size.

If reusable type filters are used, check monthly and clean with water and mild detergent when necessary. When dry, they should be sprayed with filter handicoater prior to reinstallation. Filter handicoater is RP Products coating no. 418 and is available as Lennox part no. P-8-5069.

B-Cleaning Heat Exchanger

NOTE-Use papers or protective covering in front of furnace while cleaning furnace.

Cleaning the heat exchanger is made easier with a heat exchanger clean-out kit ABRSH380 (catalog # 35K09) available from Lennox.

- 1- Remove vent pipe from furnace.
- 2- Remove locking screws and caps from cleanout tubes. Remove vent access elbow.
- 3- Using a long spiral wire brush, sweep down the outer drum of the heat exchanger. Then using the hose attachment, vacuum out loose debris.
- 4- Remove locking screw and cap from the observation tube and with the spiral wire brush, reach upward toward the rear of the heat exchanger to clean out the crossover tube.

NOTE- Do not attempt to clean the combustion chamber. It can be easily damaged.

- 5- Replace the cleanout caps and vent access elbow. Make sure locking screws are secure.
- 6- Brush out and vacuum the vent outlet area of the outer drum and replace vent pipe.
- 7- Clean around the burner, blower deck and vestibule area.

C-Annual Burner Maintenance

- 1- Replace the oil supply line filter.
- 2- Remove and clean the pump strainer if applicable.
- 3- Replace the nozzle with an equivalent nozzle.
- 4- Check the pump pressure when changing nozzle.
- 5- Clean and inspect the electrodes for damage, replacing any that are cracked or chipped.
- 6- Clean the combustion head of all lint and soot.
- 7- Inspect the transformer cables and connectors.
- 8- Remove and clean the cad cell.
- 9- Clean the blower wheel and the air control of any lint.
- 10- Check all wiring for secure connections or insulation breaks.
- 11- Re-adjust the burner as described in section IV of this manual.

D-Supply Air Blower

- 1- Disconnect power to unit.
- 2- Check and clean blower wheel.
- 3- Motors are prelubricated for extended life; no further lubrication is required.

E-Vent Pipe

The vent pipe should be inspected annually. Remove and clean any soot or ash found in the vent pipe. Vent pipe deteriorates from the inside out and must be disconnected in order to check thoroughly. Inspect pipe for holes or rusted areas. Inspect the vent control device and replace if found defective. Check for tightness and to make sure there is no blockage or leaks.

F-Electrical

- 1- Check all wiring for loose connections.
- 2- Check for correct voltage at unit (unit operating).
- 3- Check amp-draw on blower motor.
Motor Nameplate _____ Actual _____
- 4- Check to see that heat is operating.

VIII-WIRING DIAGRAMS AND SEQUENCE OF OPERATIONS

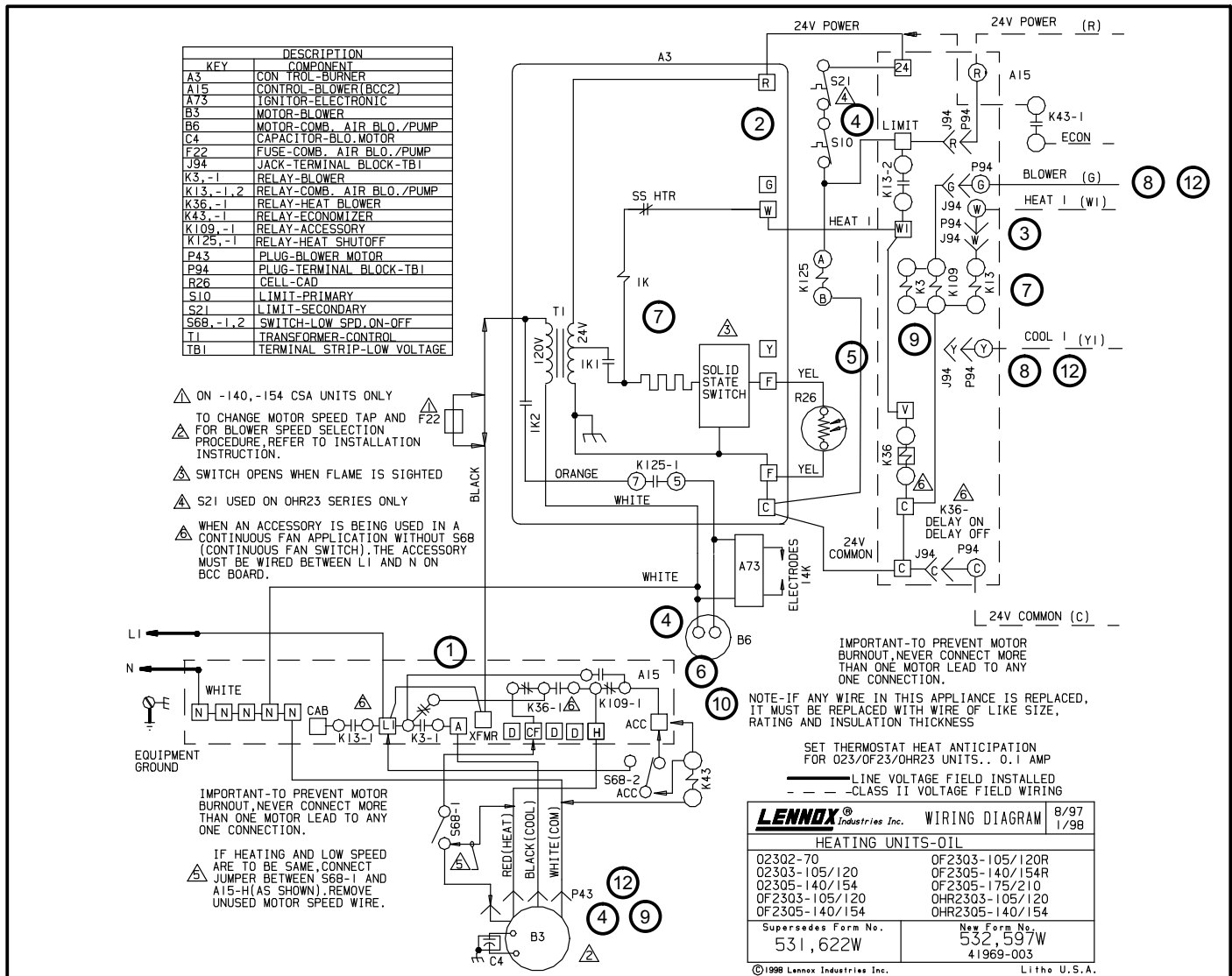

O23 / OHR23 / OF23-1 through -4 UNIT OPERATION SEQUENCE:

- When disconnect is closed, 120V is routed to the blower control board BCC2 (A15). The BCC2 feeds line voltage to transformer (T1).
- T1 supplies 24VAC to the burner control (A3). In turn, A3 supplies 24VAC to A15, which supplies the indoor thermostat (not shown) with 24VAC.
- When there is a call for heat, W1 of the thermostat energizes W of the A15 board with 24VAC.
- A15 energizes combustion air blower relay (K13). When K13-2 closes, assuming primary limit (S10) and [secondary limit (S21) in OHR units only] are closed, 24VAC is routed to 1K, which closes 1K1 and 1K2. When 1K2 closes combustion air blower / pump (B6) is energized. Simultaneously 24VAC is routed through the blower relay (K36). When K36-1 closes blower motor (B6) is energized on heating speed.
- When 1K2 closes the electronic ignitor is energized causing a 14,000VAC spark, igniting the burner. When 1K1 closes the solid state switch and cad cell are energized. When the cad cell senses light the solid state switch de-energizes the safety heater, keeping the burner operating.
- A15 energizes accessory relay (K109). When K109-1 closes the accessory terminal on the A15 board is energized with 120VAC.
- When heat demand is satisfied, W1 of the thermostat de-energizes W of the ignition control. W de-energizes K13 in turn de-energizing 1K. When 1K is de-energized B6 and A73 stop immediately. The indoor blower runs for a designated fan "off" period (90-330 seconds) as set by jumper on BCC2 control.
- When there is a call for cooling, Y1 of the thermostat energizes Y and G of the A15 board with 24VAC.
- A15 energizes blower relay K3. When K3-1 closes B3 starts on the speed set for cooling.
- A15 energizes accessory relay K109. When K109-1 closes the accessory terminal on the A15 board is energized with 120VAC.
- Provided that condensing unit is connected to Y terminal, cooling will start.
- When cooling demand is satisfied, Y1 of the thermostat de-energizes Y and G. The indoor blower and condensing unit stops immediately.

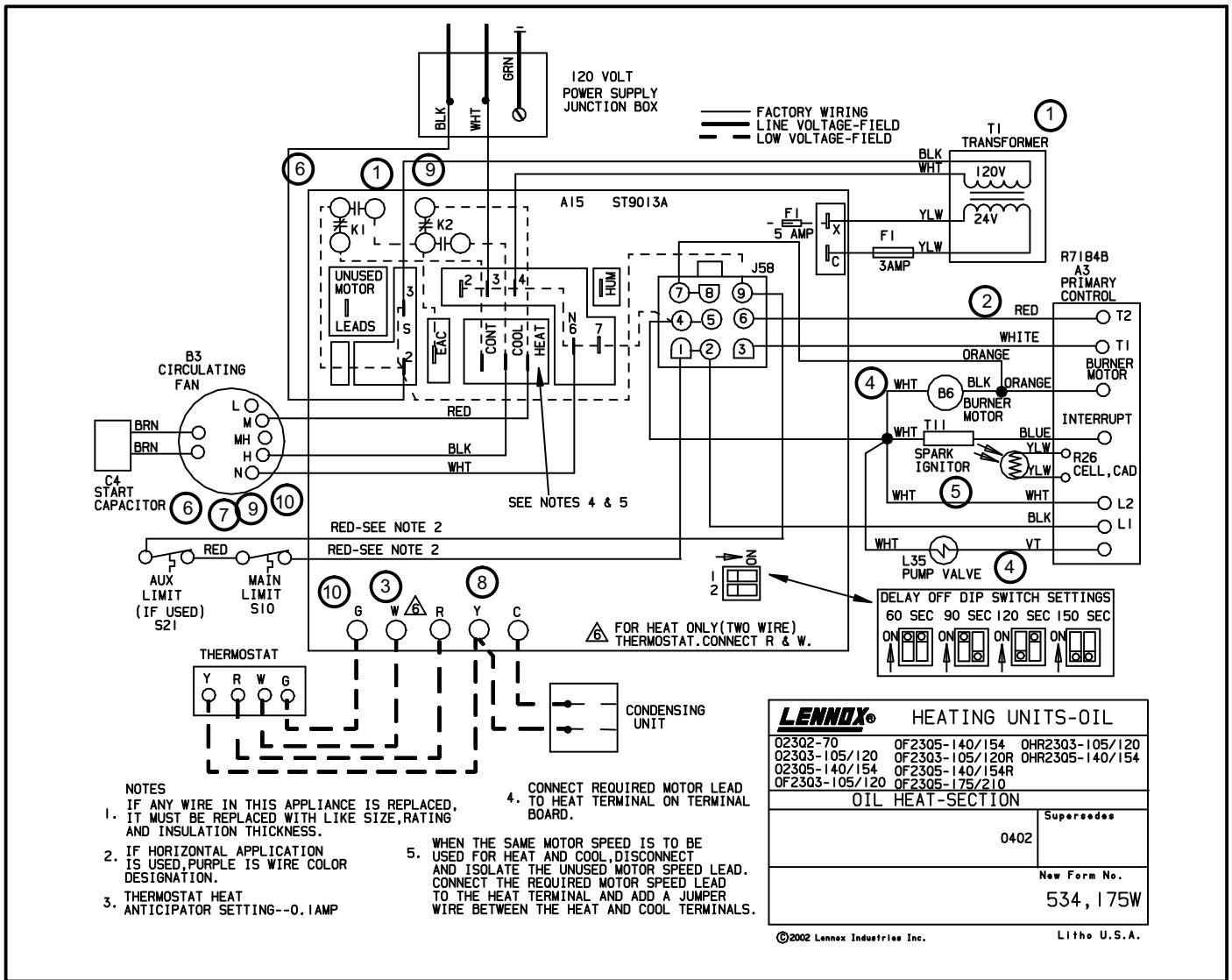

O23 / OHR23 / OF23-5 UNIT OPERATION SEQUENCE:

- When disconnect is closed, 120V is routed to the blower control board (A15). The blower control board feeds line voltage to transformer (T1).
- When there is a call for heat, W1 of the thermostat energizes W of the A15 board with 24VAC.
- A15 energizes combustion air inducer B6 assuming primary limit (S10) and [secondary limit (S21) in OHR units only] are closed.
- Burner control A3 energizes the electronic ignitor causing a 20,000VAC spark. Burner motor (B6) and pump valve (L35) are delayed for a 15 second pre-purge. The pre-purge is followed by a 15 second trial for ignition.
- After the pre-purge and trial for ignition (30 seconds) voltage passes through contactor K1 the energizing the indoor blower B3 on heating speed.
- When heat demand is satisfied, W1 of the thermostat de-energizes W of the ignition control. Combustion air inducer B6 is de-energized. The indoor blower runs for a designated fan "off" period (60-150 seconds) as set delay switch on blower control.
- When there is a call for cooling, Y1 of the thermostat energizes Y and G of the A15 board with 24VAC.
- A15 energizes relay K2. When K2 contacts close, the indoor blower B3 energizes on cooling speed.
- When cooling demand is satisfied, Y1 of the thermostat de-energizes Y and G. The indoor blower and condensing unit stops immediately.
- When there is a call for continuous fan the indoor blower (B3) is energized on cool speed. If blower control board is wired for continuous fan, the indoor blower will energize on low speed and remain energized after thermostat demand is satisfied.

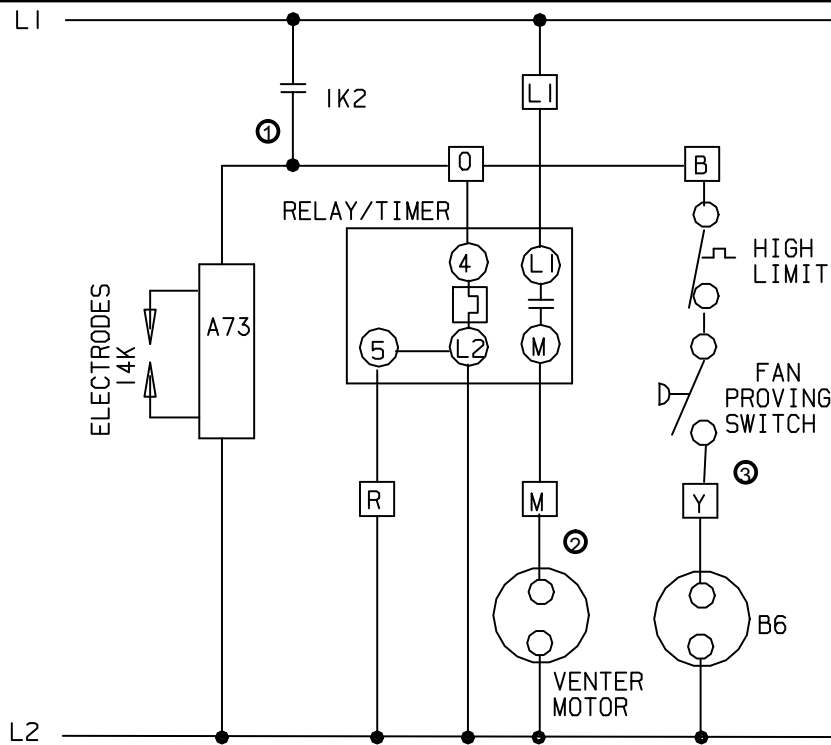

TJERNLUND HORIZONTAL VENTING SYSTEM (SIDESHOT) OPERATION SEQUENCE:

1. When 1K2 closes, 120VAC is routed through the relay/timer, electronic ignitor (A73), and the limit switch.
2. The relay/timer energizes the venter motor.
3. After the venter motor establishes a draft, the N.O. fan proving switch closes completing the circuit to the burner motor.

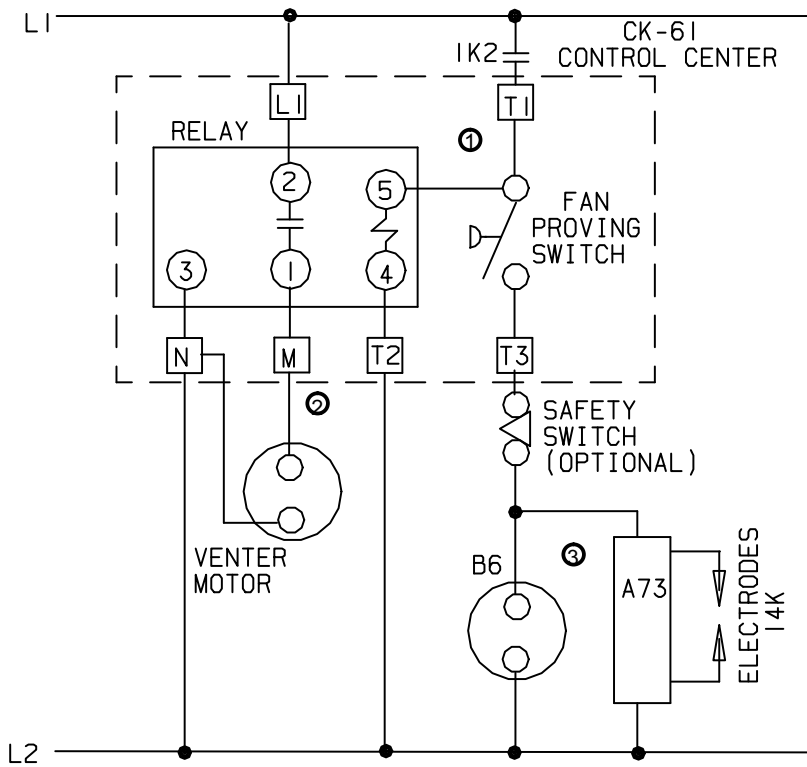

FIELD CONTROL HORIZONTAL VENTING SYSTEM OPERATION SEQUENCE:

1. When 1K2 closes, 120VAC is routed through the relay.
2. The relay energizes the venter motor.
3. After the venter motor establishes a draft, the N.O. fan proving switch closes, completing the circuit to the burner motor and electronic ignitor (A73).

IX-TROUBLESHOOTING

Burner failure or improper unit operation can be caused by various conditions. Often the problem can be solved by a logical process of checks and eliminations. The following pages lists a few common problems along with the solutions. Carefully check the most obvious items first before proceeding to more involved procedures.

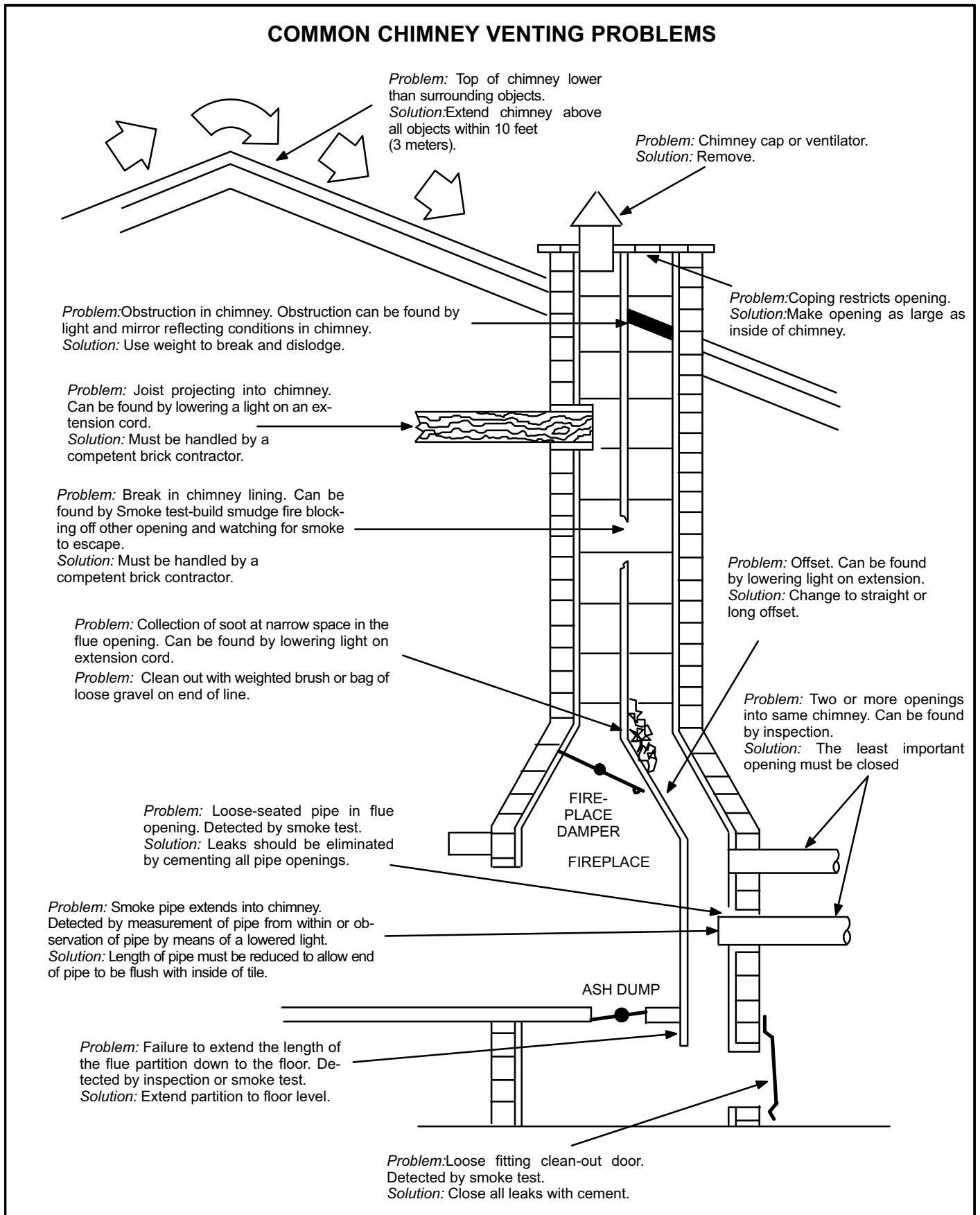

BCC2 / BCC3 TROUBLESHOOTING FLOWCHART

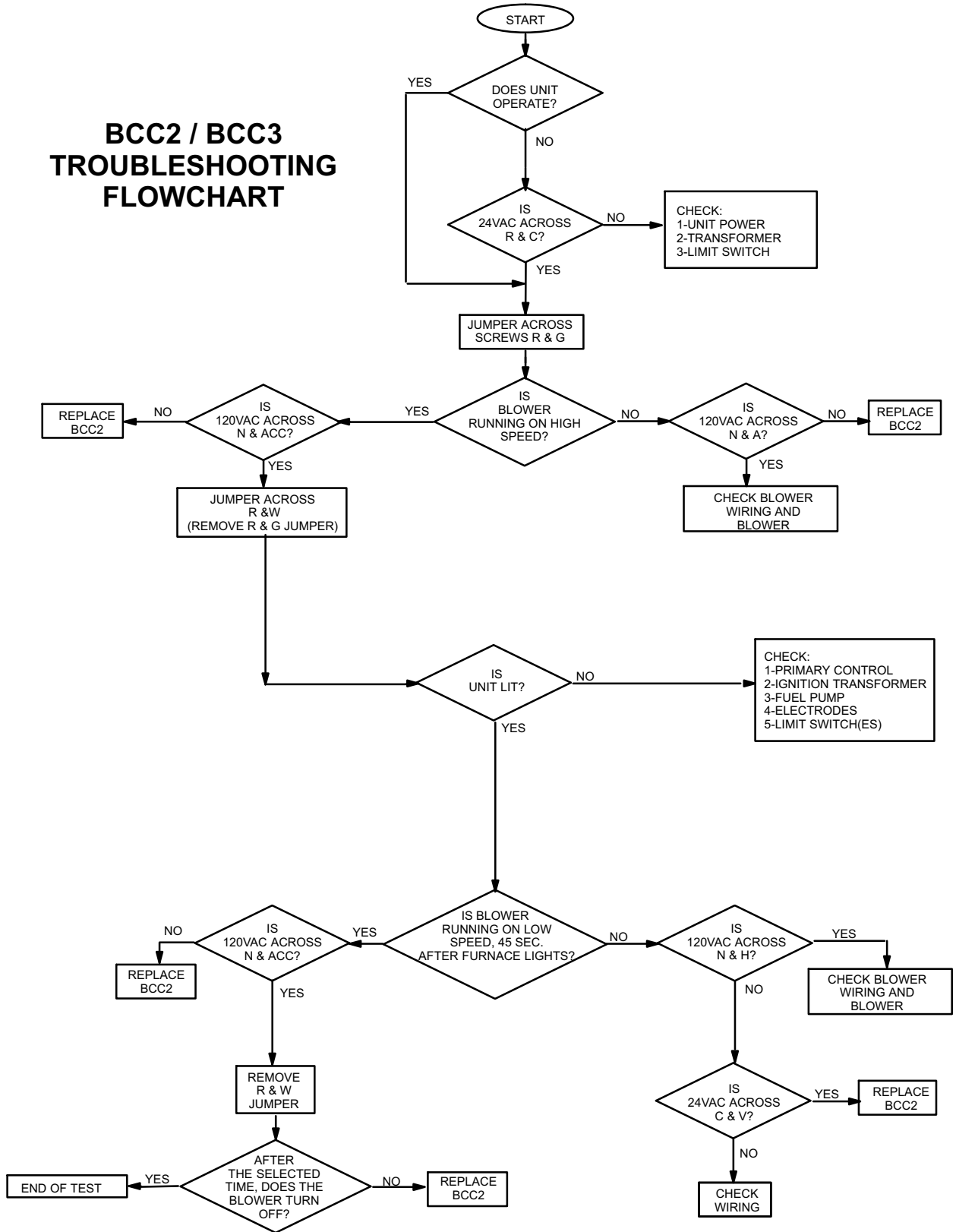

Troubleshooting: Blower Control ST9103A

Action	System Response
Thermostat calls for heat. (W terminal is energized.)	ST9103A closes oil primary control T-T connections. Ignition system and oil primary control start the furnace. Oil flows as long as oil primary control senses flame. Burner motor is energized and heat fan on delay timing begins. When timing is complete, the circulating fan is energized at heat speed and warm air is delivered to the controlled space.
Thermostat ends call for heat. (W terminal is de-energized.)	Oil primary control is de-energized, terminating the burner cycle. Heat fan off delay timing begins. When timing is complete, the circulating fan is de-energized. ST9103A returns to standby mode (oil primary control and circulating fan are off).
Burner fails to light.	Oil primary control locks out within lockout timing (timing depends on oil primary control). Burner motor is de-energized. If heat fan has started, it continues through the selected delay off period.
Established flame fails.	Burner motor is de-energized and oil primary control goes into recycle mode. If selected heat fan off delay is longer than the recycle delay timing, the heat fan continues to run through the next trial for ignition.
Thermostat begins call for cool. (G and Y terminals are energized.)	Circulating fan is energized at the cool speed. Cooling compressor turns on immediately.
Thermostat ends call for cool. (G and Y terminals are de-energized.)	Circulating fan and cooling compressor turn off immediately.
Thermostat begins call for fan. (G terminal is energized.)	Circulating fan is energized immediately at cool speed. ST9103A may be factory-configured to operate heat speed in this mode.
Thermostat ends call for fan. (G terminal is de-energized.)	Circulating fan is de-energized.
Limit switch string opens.	Oil primary control shut off the burner. Circulating fan is energized immediately at heat speed. ST9103A opens oil primary control T-T connections. Circulating fan runs as long as limit string stays open. If there is a call for cooling or fan, the circulating fan switches from heat speed to cool speed.
Limit switch string closes.	ST9103A begins heat fan off delay sequence. Circulating fan turns off after the selected heat fan off delay timing. ST9103A closes oil primary control T-T connections. Oil primary control is energized, initiating burner light off.
Continuous circulating fan is connected. (Optional connectors are available for separate circulating fan speed tap.)	Circulating fan is energized at low speed when there is no call for heat, cool or fan. If fan operation is required by a call for heat, cool, or fan, the ST9103A switches off the continuous fan speed tap before energizing the other fan speed.
Electronic air cleaner is connected. (Optional connectors are available for 120 Vac electronic air cleaner.)	Electronic air cleaner (EAC) connections are energized when the heat or cool speed of the circulating fan is energized. EAC connections are <i>not</i> energized when the optional continuous fan terminal is energized.
Humidity control is connected. (Optional connectors are available for 120 Vac humidifier.)	Humidifier connections are energized when the burner motor is energized.

Troubleshooting O23 / OHR23 / OF23 -1 through -4 Units

Burner fails to start.

Source	Procedure	Causes	Correction
Thermostat	Check thermostat settings.	Thermostat in OFF or COOL	Switch to HEAT .
		Thermostat is set too low	Turn thermostat to higher temperature.
Safety Overloads	Check burner motor, primary safety control, & auxiliary limit switch.	Burner motor overload tripped	Push reset button pump motor.
		Primary control tripped on safety	Reset primary control.
		Auxiliary limit switch tripped on safety	Reset auxiliary limit.
Power	Check furnace disconnect switch & main disconnect.	Open switch	Close switch.
		Blown fuse or tripped circuit breaker	Replace fuse or reset circuit breaker.
Thermostat	Touch jumper wire across thermostat terminals on primary control. If burner starts, then fault is in the thermostat circuit.	Broken or loose thermostat wires	Repair or replace wires.
		Loose thermostat screw connection	Tighten connection.
		Dirty thermostat contacts	Clean contacts.
		Thermostat not level	Level thermostat.
		Faulty thermostat	Replace thermostat.
CAD Cell	Disconnect the flame detector wires at the primary control. If the burner starts, fault is in the detector circuit.	Flame detector leads are shorted	Separate leads.
		Flame detector exposed to light	Seal off false source of light.
		short circuit in the flame detector	Replace detector.
Primary Control	Place trouble light between the black and white leads. No light indicates that no power is going to the control.	Primary or auxiliary control switch is open	Check adjustment. Set the maximum setting.
			Jumper terminals; if burner starts, switch is faulty, replace control.
		Open circuit between disconnect switch and limit control	Trace wiring and repair or replace it.
	Low line voltage or power failure	Call the power company.	
	Place trouble light between the orange and white leads. No light indicates faulty control.	Defective internal control circuit	Replace the control.
Burner	Place the trouble light between the black and white leads to the burner motor. No light indicates that no power is getting to the motor.	Blown fuse	Replace the fuse.
		Place trouble light between the black and white leads to the blower motor. Light indicates power to the motor and burner fault.	Binding burner blower wheel
	Sized fuel pump		
		Defective burner motor	Replace the motor.

Burner starts, but no flame is established.

Source	Procedure	Causes	Correction
Oil Supply	Check tank gauge or use dip stick.	No oil in tank	Fill tank.
	Coat dip stick with litmus paste and insert into bottom of tank.	Water in oil tank	If water depth exceeds 1 inch, pump or drain water.
	Listen for pump whine.	Tank shut-off valve closed	Open valve.
Oil Filters & Oil Line	Listen for pump whine.	Oil line filter is plugged	Replace filter cartridges.
		Kinks or restriction in oil line	Repair or replace oil line.
		Plugged fuel pump strainer	Clean strainer or replace pump.
	Open bleed valve or gauge port. Start the burner. No oil or milky oil indicates loss or prime.	Air leak in oil supply line	Locate and correct leak. Tighten all connections.
Oil Pump	Install pressure gauge on pump and read pressure. Should not be less than 140 psi.	Pump is partially or completely frozen. No pressure and the motor locks out on overload.	Replace pump.
		Coupling disengaged or broken - no pressure	Re-engage or replace coupling.
		Fuel pressure too low	Adjust to 100 psi.
Nozzle	Disconnect ignition leads. Observe the oil spray (gun assembly must be removed from unit). Inspect the nozzle for plugged orifice or carbon build-up around orifice.	Nozzle orifice plugged	Replace nozzle with the same size, spray angle, and spray type.
		Nozzle strainer plugged	
		Poor or off center spray	
Ignition Electrodes	Remove gun assembly and inspect electrodes and leads.	Fouled or shorted electrodes	Clean electrode leads.
		Dirty electrodes and leads	
		Eroded electrode tips	Clean electrode tips and reset the gap to 5/32 inches and correctly position tips.
		Improper electrode gap spacing	
		Improper position of electrode tips	Retension and realign.
		Bad buss bar connection	Replace electrode.
		Cracked or chipped insulators	Replace electrode leads.
Cracked or burned lead insulators			
Ignition Transformer	Connect ignition leads to the transformer. Start burner and observe spark. Check line voltage to transformer primary.	Low line voltage	Check voltage at power source. Correct cause of voltage drop or call the power company.
		Burned out transformer windings.	Replace the transformer.
		No spark or weak spark	Properly ground the transformer case.
Burner Motor	Motor does not come up to speed and trips out on overload. Turn off power and rotate blower wheel by hand to check for binding or excessive drag.	Low line voltage	Check voltage at power source. Correct cause of voltage drop or the call power company.
		Pump or blower overloading motor	Correct cause of overloading.
		Faulty motor	Replace motor.

Burner starts and fires, but locks out on safety.

Source	Procedure		Causes	Correction
Poor Fire	After burner fires, immediately jumper across flame detector terminals at the primary control.	If burner continues to run, this may be due to poor fire. Inspect fire.	Unbalanced fire	Replace nozzle
			Too much air - -lean short fire	Reduce combustion air - check combustion.
			Too little air - - long dirty fire	Increase combustion air - check combustion.
			Excessive draft	Adjust barometric damper for correct draft.
			Too little draft or restriction	Correct draft or remove restriction.
Flame Detector	If fire is good, fault is in the flame detector. Check detector circuit.	Dirty cad cell face	Clean cad cell face.	
		Faulty cad cell - exceeds 1500 hms	Replace cad cell.	
		Loose or defective cad cell wires	Secure connections or replace cad cell holder and wire leads.	
Primary Control	If burner locks out on safety, fault is in the primary control.	Primary control circuit defective	Replace primary control.	

Burner starts and fires, but loses flame and locks out on safety.

Source	Procedure		Causes	Correction
Poor Fire	After burner fires, immediately jumper across flame detector terminals at the primary control.	If burner continues to run (does not lock out of safety), fault may be due to poor fire. Inspect fire.	Unbalanced fire	Replace nozzle
			Too much air - - lean short fire	Reduce combustion air - check combustion.
			Too little air - - long dirty fire	Increase combustion air - check combustion.
			Excessive draft	Adjust barometric damper for correct draft.
			Too little draft or restriction	Correct draft or remove restriction.
Flame Detector	If fire is good, fault is in the flame detector. Check detector circuit.	Dirty CAD cell face	Clean CAD cell face.	
		Faulty CAD cell - - exceeds 15000 hms	Replace CAD cell.	
		Loose or defective cad cell wires	Secure connections or replace cad cell holder and wire leads.	
Oil Supply	If burner loses flame (does not lock out on safety), fault is in the fuel system.	Pump loses prime - air slug	Prime pump at bleed port	
		Pump loses prime - air leak in supply line	Check supply line for loose connections and tighten fittings.	
		Water slug in line	Check oil tank for water (over 1 inch) pump or drain out water.	
	Listen for pump whine	Partially plugged nozzle or nozzle strainer	Replace nozzle.	
		Restriction in oil line	Clear restriction.	
Plugged fuel pump strainer		Clean strainer or replace pump.		
		Cold oil - outdoor tank	Change to number 1 oil.	

Burner starts and fires, but short cycles (too little heat).

Source	Procedure	Causes	Correction
Thermostat	Check thermostat.	Heat anticipator set too low	Correct heat anticipator setting.
		Vibration at thermostat	Correct source of vibration.
		Thermostat in the path of a warm air draft	Shield thermostat from draft or relocate.
Limit Control	Connect voltmeter between line voltage connections to primary control (black & white leads). If burner cycles due to power interruption, it is cycling on limit.	Dirty furnace air filters	Clean or replace filter.
		Burner running too slow	Increase blower speed to maintain proper temp. rise.
		Blower motor seized or burned out	Replace motor.
		Blower bearings seized	Replace bearings and shaft.
		Blower wheel dirty	Clean blower wheel.
		Blower wheel in backward	Reverse blower wheel.
		Wrong motor rotation	Replace with properly rotating wheel.
		Restrictions in return or supply air system	Correct cause of restriction.
		Adjustable limit control set too low	Reset limit to maximum stop setting.
Power	If voltage fluctuates, fault is in the power source. Recheck voltage at the power source.	Loose wiring connection	Locate and secure connection.
		Low or fluctuating line voltage	Call power company.

Burner runs continuously (too much heat).

Source	Procedure		Causes	Correction
Thermostat	Disconnect thermostat wires at the primary control.	If burner turns off, fault is in the thermostat circuit.	Shorted or welded thermostat contacts	Repair or replace the thermostat.
			Stuck thermostat bimetal	Clear obstruction or replace thermostat.
			Thermostat not level	Level thermostat.
			Shorted thermostat wires	Repair short or replace wires.
			Thermostat out of calibration	Replace thermostat.
			Thermostat in cold draft	Correct draft or relocate the thermostat.
Primary control		If burner does not turn off, fault is in the primary control.	Defective primary control	Replace the defective primary control.

Burner runs continuously cont.

Source	Procedure		Causes	Correction
Combustion	Check burner combustion for CO ₂ , stack temperature, and smoke	Low CO ₂ less than 10%.	Too much combustion air	Reduce combustion air.
			Air leaks into heat exchanger around inspection door, etc.	Correct cause of air leak.
			Excessive draft	Adjust barometric draft control for correct draft.
			Incorrect burner head adjustment	Correct burner head setting.
		High smoke reading more than a trace.	Dirty or plugged heat exchanger	Clean heat exchanger. Readjust burner.
			Insufficient draft	Increase draft.
			Incorrect burner head adjustment	Correct burner setting.
			Too little combustion air	Increase combustion air.
		High stack temperature is more than 550°F Net.	Too little blower air	Increase blower speed to maintain proper temp. rise.
			Blower belt too loose (if equipped)	Tighten blower belt.
			Dirty or plugged heat exchanger	Clean heat exchanger.
			Dirty blower wheel	Clean blower wheel.
Dirty furnace air filters	Clean or replace filter.			
		Restricted or closed registers or dampers	Readjust registers or dampers.	
Oil Pressure	Inspect fire and check oil pressure.		Partially plugged or defective nozzle	Replace nozzle.
			Oil pressure is too low: less than 100 psi.	Increase oil pressure top 100psi.

Troubleshooting O23 / OHR23 / OF23 -5 Units

Procedure	Status	Correction
CONDITION 1: BURNER DOES NOT ENERGIZE WITH A CALL FOR HEAT.		
1.1 Check limit switch contacts are closed and clean.		Clean contacts. Replace limit switch if necessary.
1.2 Check for line voltage at oil primary control. Voltage should be 120V		Check primary voltage source. Take appropriate measures to correct if necessary.
1.3 Check LED light with burner off, no call for heat (no flame)	LED is on	Cad cell or control is bad. Control sees external light or connections are shorted. See step 1.4.
	LED is off	See step 1.5.
1.4 Shield cad cell from external light	LED is off	Eliminate external light or shield light from cad cell
	LED stays on	Replace cad cell and recheck. <ul style="list-style-type: none"> • If LED stays on remove cad cell lead wires from burner control and recheck. • If LED turns off, replace cad cell bracket assembly. • If LED stays on replace burner control
1.5 On warm air systems, Remove one thermostat lead and jumper thermostat (T to T) terminals on burner control.	Burner energizes	Trouble in thermostat or limit circuit. Check thermostat or limit wiring connections.
	Burner does not energize	Disconnect line voltage power and open line switch <ul style="list-style-type: none"> • Check all wiring and tighten any loose connections. Recheck • If burner does not energize replace burner control

Troubelshooting O23 / OHR23 / OF23 -5 Units Cont.

CONDITION 2: BURNER STARTS, THEN LOCKS OUT ON SAFETY WITH LED FLASHING 1/2 SECOND ON 1/2 SECOND OFF		
2.1 Check limit switch contacts are closed and clean.		Clean contacts. Replace limit switch if necessary.
2.2 Check for line votage at oil pri- mary control. Voltage should be 120V		Check primary voltage source. Take appropriate measures to cor- rect if necessary.
2.3 Check LED light with burner off, no call for heat (no flame)	LED is on	Cad cell or control is bad. Control sees external light or connections are shorted. See step 2.4.
	LED is off	See step 2.5.
2.4 Sheild cad cell from external light	LED is off	Eliminate exteranal light or shield light from cad cell
	LED stays on	Replace cad cell and recheck. • If LED stays on remove cad cell lead wires from burner control and recheck. • If LED turns off, replace cad cell bracket assembly. • If LED stays on replace buner control
2.5 On warm air systems, Remove one thermostat lead and jumper thermostat (T to T) terminals on burner control.	Burner energizes	Trouble in thermostat or limit circuit. Check thermostat or limit wir- ing connections.
	Burner does not energize	Disconnect line voltage power and open line switch • Check all wiring and tighten any loose connections. Recheck • If burner does not energize replace burner control
2.6 Hit reset button on burner con- trol	LED stops flashing	See step 2.7.
	LED continuse to flash	Verify burner control is not in restricted mode. (1/2 second flash)
2.7 Listen for spark after burner en- ergizes (after 2 second delay)	Ignition is off	Ignitor could be bad. Check line voltage at ignitor terminals. If line voltage is present, replace burner control
	Ignition is on	Wait for 15 second pre-purge to complete. Check oil valve, oil valve wiring, pump and oil supply.
	Ignition is on but no oil is sprayed to combustion cham- ber	
2.8 Check LED after flame is estab- lished, but before buner control lockcs out.	LED is on until the burner control locks out and starts flashing during lock out.	Replace burner control
2.9 Check cad cell sighting for view of flame • Disconnect line voltage and open line switch • Unplug cad cell and clean cad cell face with soft cloth. Check sighting for clear view of flame. Place cad cell back in socket. • Reconnect line voltage and close line switch. Start burner	Burner locks out	See step 2.10
	Burner continuse to run	System is O.K
2.10 Check cad cell. • Disconnect line voltage and open line switch • Replace cad cell with new cad cell • Disconnect all wires from thermo- stat to prevent a call for herat. • Reconnect line voltage and close line switch. • Expose new cad cell to bright light, such as a flash light	LED is on.	Go back to step 2.6
	LED is off.	See step 2.11
2.11 Check cad cell bracket assem- bly. • Disconnect line voltage and open line switch • Remove cad cell wires from quick connect connectors on the burner control and leave wires open. • Apply power to buner control. • Place jumper across cad cell termi- nals after buner motor is energized.	LED is on.	Replace cad cell assembly.
	LED is off.	Replace burner control.