



**VRF**  
**V0CTRL88P-1**  
**Key Card Interface Module**

Bulletin No. 210713

July 2014

**PRODUCT SPECIFICATIONS**

Key Card Interface Module locks and unlocks control to heating/cooling system.

Inserting a keycard allows control access to system during occupied times, removing keycard disables system operation during unoccupied times.

A standard wired controller or wireless remote controller (ordered separately) is used to operate system during occupied times.

**FEATURES**

- **Run LED** - Indicates that system is operating.
- **Connections** - Connections are provided for the building control system (on/off relay control) and the heating/cooling system main control board on indoor unit.
- **Power** - No external power supply required.
- **Dimensions (H x W x D)** - 3-3/8 x 2-7/8 x 5/8 in. Control can be mounted on a standard electrical handy box or on a wall. Additional hardware is furnished for installation.

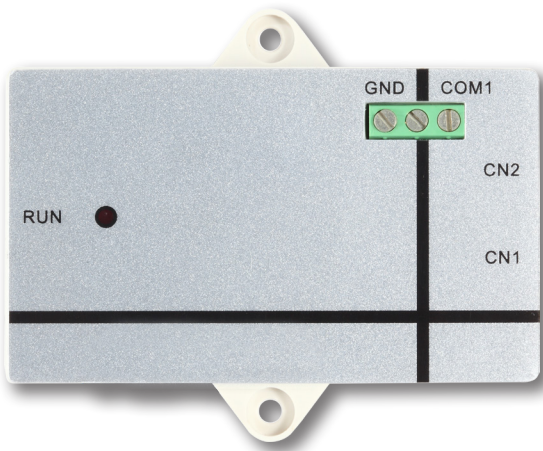

**SYSTEM OVERVIEW**

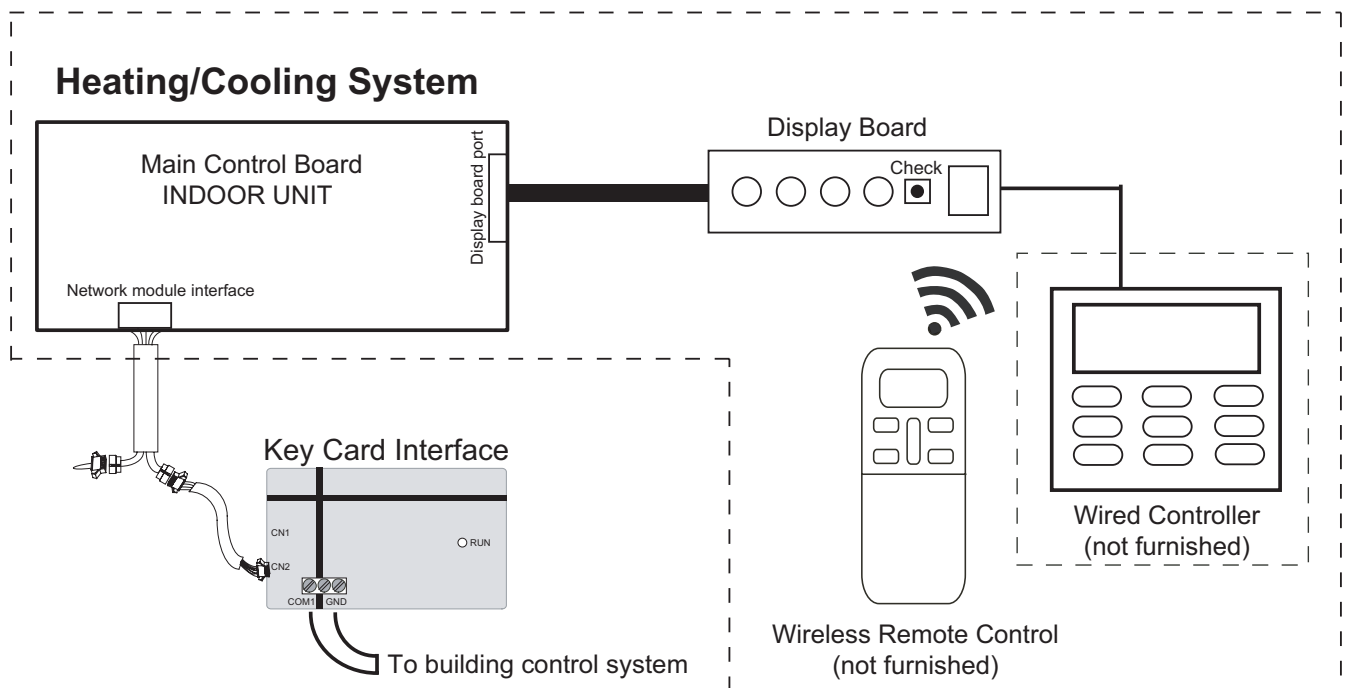



Visit us at [www.lennox.com](http://www.lennox.com)

For the latest technical information, [www.lennoxcommercial.com](http://www.lennoxcommercial.com)

Contact us at 1-800-4-LENNOX

NOTE - Due to Lennox' ongoing commitment to quality, Specifications, Ratings and Dimensions subject to change without notice and without incurring liability.  
Improper installation, adjustment, alteration, service or maintenance can cause property damage or personal injury.  
Installation and service must be performed by a qualified installer and servicing agency.

©2014 Lennox Industries, Inc.