

**SLP99UHV SERIES UNITS**

SLP99UHV series units are high-efficiency upflow, horizontal right and left) gas furnaces equipped with variable capacity gas valve, variable speed combustion air inducer and variable speed indoor blower motor. All models are designed only for direct vent (dual pipe) venting system.

SLP99UHV units are available in heating capacities from 66,000 to 132,000 Btuh (19.3 to 38.6 kW) and cooling applications from 2 to 5 tons (7.0 kW to 17.5 kW). Refer to Engineering Handbook for proper sizing.

Units are factory-equipped for use with natural gas. Kits are available for conversion to LPG operation. SLP99UHV models include a SureLight® variable capacity integrated control that can be used with a Lennox communicating thermostat as part of a communicating comfort system. All SLP99UHV units meet the California Nitrogen Oxides (NOx) Standards and California Seasonal Efficiency requirements.

All specifications in this manual are subject to change. Procedures outlined in this manual are presented as recommendations only and do not supersede or replace local or state codes. In the absence of local or state codes, the guidelines and procedures outlined in this manual (except where noted) are recommendations only and do not constitute code.

**TABLE OF CONTENTS**

Specifications . . . . . Page 2  
 Optional Accessories . . . . . Page 3  
 Blower Data . . . . . Page 4  
 I Unit Components . . . . . Page 20  
 II Communicating Thermostat . . . . . Page 44  
 III Placement and Installation . . . . . Page 47  
 IV Start Up . . . . . Page 63  
 V Heating System Service Checks . . . . . Page 60  
 VI Typical Operating Characteristics . . . . . Page 69  
 VII Maintenance . . . . . Page 71  
 VIII Wiring and Sequence of Operation . . . . . Page 74  
 XI Field Wiring . . . . . Page 82



**⚠ WARNING**  
 Improper installation, adjustment, alteration, service or maintenance can cause property damage, personal injury or loss of life. Installation and service must be performed by a licensed professional HVAC installer or equivalent, service agency, or the gas supplier.

**⚠ WARNING**  
 Electric shock hazard. Can cause injury or death. Before attempting to perform any service or maintenance, turn the electrical power to unit OFF at disconnect switch(es). Unit may have multiple power supplies.



**⚠ CAUTION**  
 As with any mechanical equipment, contact with sharp sheet metal edges can result in personal injury. Take care while handling this equipment and wear gloves and protective clothing.

## SPECIFICATIONS

Gas	Model No.	SLP99UH070XV36B	SLP99UH090XV36C	SLP99UH090XV48C	
<b>Heating Performance</b>	<sup>1</sup> AFUE	98.1%	98.1%	98.2%	
<b>Maximum</b>	Input - Btuh	66,000	88,000	88,000	
	Output - Btuh	64,000	85,000	85,000	
	Temperature rise range - °F	50 - 80	60 - 90	50 - 80	
	Gas Manifold Pressure (in. w.g.) Nat. Gas / LPG/Propane	3.5 / 10.0	3.5 / 10.0	3.5 / 10.0	
	<b>Minimum</b>	Input - Btuh	23,000	31,000	31,000
		Output - Btuh	22,000	30,000	30,000
		Temperature rise range - °F	35 - 65	35 - 65	35 - 65
		Gas Manifold Pressure (in. w.g.) Nat. Gas / LPG/Propane	0.5 / 1.5	0.5 / 1.5	0.5 / 1.5
		High static - in. w.g.	0.8	0.8	0.8
	<b>Connections in.</b>	Intake / <sup>2</sup> Exhaust Pipe (PVC)	2 / 2	2 / 2	2 / 2
Gas pipe size IPS		1/2	1/2	1/2	
Condensate Drain Trap (PVC pipe) - i.d.		3/4	3/4	3/4	
with furnished 90° street elbow		3/4 slip x 3/4 Mipt	3/4 slip x 3/4 Mipt	3/4 slip x 3/4 Mipt	
with field supplied (PVC coupling) - o.d.		3/4 slip x 3/4 MPT	3/4 slip x 3/4 MPT	3/4 slip x 3/4 MPT	
<b>Indoor Blower</b>	Wheel nominal diameter x width - in.	10 x 9	10 x 9	11 x 11	
	Motor output - hp	1/2	1/2	3/4	
	Tons of add-on cooling	2 - 3	2 - 3.5	2.5 - 4	
	Air Volume Range - cfm	339 - 1365	520 - 1360	528 - 1770	
<b>Electrical Data</b>	Voltage (Maximum Amps)	120 volts - 60 Hertz - 1 phase			
	Blower motor full load amps	7.7	7.7	10.1	
	Maximum overcurrent protection	15	15	15	
<b>Shipping Data</b>	lbs. - 1 package	139	156	166	

NOTE - Filters and provisions for mounting are not furnished and must be field provided.

<sup>1</sup> Annual Fuel Utilization Efficiency based on DOE test procedures and according to FTC labeling regulations. Isolated combustion system rating for non-weatherized furnaces.

<sup>2</sup> 2 in. Rubber Flue Coupling is furnished for exhaust pipe connection to unit.

## SPECIFICATIONS

Gas	Model No.	SLP99UH090XV60C	SLP99UH110XV60C	SLP99UH135XV60D	
<b>Heating Performance</b>	<sup>1</sup> AFUE	99%	98.1%	98.4%	
<b>Maximum</b>	Input - Btuh	88,000	110,000	132,000	
	Output - Btuh	87,000	106,000	128,000	
	Temperature rise range - °F	50 - 80	50 - 80	55 - 85	
	Gas Manifold Pressure (in. w.g.) Nat. Gas / LPG/Propane	3.5 / 10.0	3.5 / 10.0	3.5 / 10.0	
	<b>Minimum</b>	Input - Btuh	31,000	39,000	46,000
		Output - Btuh	30,000	38,000	45,000
		Temperature rise range - °F	25 - 55	35 - 65	35 - 65
		Gas Manifold Pressure (in. w.g.) Nat. Gas / LPG/Propane	0.5 / 1.5	0.5 / 1.5	0.5 / 1.5
		High static - in. w.g.	0.8	0.8	0.8
	<b>Connections in.</b>	Intake / <sup>2</sup> Exhaust Pipe (PVC)	2 / 2	2 / 2	2 / 2
Gas pipe size IPS		1/2	1/2	1/2	
Condensate Drain Trap (PVC pipe) - i.d.		3/4	3/4	3/4	
with furnished 90° street elbow		3/4 slip x 3/4 Mipt	3/4 slip x 3/4 Mipt	3/4 slip x 3/4 Mipt	
with field supplied (PVC coupling) - o.d.		3/4 slip x 3/4 MPT	3/4 slip x 3/4 MPT	3/4 slip x 3/4 MPT	
<b>Indoor Blower</b>	Wheel nominal diameter x width - in.	11 x 11	11 x 11	11 x 11	
	Motor output - hp	1	1	1	
	Tons of add-on cooling	3 - 5	3 - 5	3.5 - 5	
	Air Volume Range - cfm	380 - 2195	580 - 2125	646 - 2190	
<b>Electrical Data</b>	Voltage (Maximum Amps)	120 volts - 60 Hertz - 1 phase			
	Blower motor full load amps	12.8	12.8	12.8	
	Maximum overcurrent protection	20	20	20	
<b>Shipping Data</b>	lbs. - 1 package	166	176	191	

NOTE - Filters and provisions for mounting are not furnished and must be field provided.

<sup>1</sup> Annual Fuel Utilization Efficiency based on DOE test procedures and according to FTC labeling regulations. Isolated combustion system rating for non-weatherized furnaces.

<sup>2</sup> 2 in. Rubber Flue Coupling is furnished for exhaust pipe connection to unit.

## OPTIONAL ACCESSORIES - ORDER SEPARATELY

NOTE - FURNACES CANNOT BE TWINNED!

		"B" Width Models	"C" Width Models	"D" Width Models		
<b>CABINET ACCESSORIES</b>						
Horizontal Suspension Kit - Horizontal only		51W10	51W10	51W10		
Return Air Base - Upflow only		50W98	50W99	51W00		
High Performance Economizer (Commercial Only)		10U53	10U53	10U53		
<b>CONDENSATE DRAIN KITS</b>						
Condensate Drain Heat Cable	6 ft.	26K68	26K68	26K68		
	24 ft.	26K69	26K69	26K69		
Crawl Space Vent Drain Kit	US	51W18	51W18	51W18		
	Canada	15Z70	15Z70	15Z70		
<b>CONTROLS</b>						
iComfort® S30 Ultra-Smart Wi-Fi Thermostat		12U67	12U67	12U67		
<sup>1</sup> Remote Outdoor Air Temperature Sensor		X2658	X2658	X2658		
Night Service Kit		20F44	20F44	20F44		
<b>FILTER KITS</b>						
<sup>2</sup> Air Filter and Rack Kit	Horizontal (end)	Size of filter - in.	87L96	87L97	87L98	
		18 x 25 x 1	20 x 25 x 1	25 x 25 x 1		
	Side Return	Single	44J22	44J22	44J22	
		Ten Pack	66K63	66K63	66K63	
		Size of filter - in.	16 x 25 x 1	16 x 25 x 1	16 x 25 x 1	
<b>TERMINATION KITS</b>						
Direct Vent Applications Only. See Installation Instructions for specific venting information.						
Direct Vent	Concentric	US - 2 in.	71M80	69M29	---	
		3 in.	---	60L46	60L46	
		Canada - 2 in.	44W92	44W92	---	
		3 in.	---	44W93	44W93	
		Flush-Mount	US - 2, 2-1/2 or 3 in.	51W11	51W11	51W11
			Canada - 2, 2-1/2 or 3 in.	51W12	51W12	51W12
	Wall - Close Couple	US - 2 in.	22G44	---	---	
		3 in.	44J40	44J40	44J40	
	Wall - Close Couple WTK	Canada - 2 in.	30G28	---	---	
		3 in.	81J20	81J20	81J20	
	Roof Termination Flashing Kit (no vent pipe - 2 flashings)	2 in.	15F75	15F75	---	
		3 in.	44J41	44J41	44J41	

<sup>1</sup> Remote Outdoor Temperature Sensor is used with conventional (non-iComfort® Communicating) outdoor units (sensor is furnished with iComfort® Communicating outdoor units). Allows the thermostat to display outdoor temperature. Required in dual-fuel and EDA applications.

<sup>2</sup> Cleanable polyurethane frame type filter.

NOTE - Termination Kits (44W92, 44W93, 30G28, 51W12, 81J20) and Crawl Space Vent Drain Kit (15Z70) are certified to ULC S636 standard for use in Canada only.

## BLOWER DATA

### SLP99UH070XV36B BLOWER PERFORMANCE (less filter)

#### BOTTOM RETURN AIR

#### HEATING BLOWER PERFORMANCE - 0 through 0.8 in. w.g. External Static Pressure Range

Heating Adjust CFM Selections	Heating Input Range and Blower Volume - CFM							
	35%	40%	50%	60%	70%	80%	90%	100%
Increase (+15%) Heat CFM	489	538	636	735	833	931	1030	1128
Increase (+7.5%) Heat CFM	450	496	588	680	772	864	956	1048
Default Heat CFM	410	453	539	624	710	796	881	967
Decrease (-7.5%) Heat CFM	380	419	498	578	657	736	815	895
Decrease (-15%) Heat CFM	349	385	458	531	604	676	749	822

#### COOLING BLOWER PERFORMANCE - 0 through 1.0 in. w.g. External Static Pressure Range

Cooling Adjust CFM Selections	Blower Speed Selections							
	First Stage Cool Speed - cfm				Second Stage Cool Speed - cfm			
	Low	Medium-Low	Medium High	High (Default)	Low	Medium-Low	Medium High	High (Default)
Increase (+10%) Cool CFM	600	740	840	970	860	1060	1215	1365
Default Cool CFM	555	665	770	855	810	960	1130	1265
Decrease (-10%) Cool CFM	500	600	680	790	705	840	1005	1140

The effect of static pressure is included in air volumes shown.

The following control configurations are available. See Installation Instructions for details and DIP switch settings.

#### Heat Modes Available (Heating Blower Performance Table):

Single stage thermostat:

- 35%, 70%, 100% input (three-stage) with time delays in-between.

Two-stage thermostat:

- Variable Rate Capacity Mode - furnace automatically adjusts firing rate based on first- and second-stage cycle times.
- W1 demand at 70% input, W2 demand at 100% input. No delay between stages.

#### Cool Mode Available (Cooling Blower Performance table):

First stage COOL (two-stage air conditioning units only) is approximately 70% of the same second stage COOL speed position.

Continuous Fan speeds are approximately 28% and 38% (DIP switch selectable) of the same second-stage COOL speed position. minimum 250 cfm.

Lennox iHarmony® Zoning System Applications - Minimum blower speed is 250 cfm.

**SLP99UH070XV36B BLOWER PERFORMANCE (less filter)**

**SINGLE SIDE RETURN AIR**

**HEATING BLOWER PERFORMANCE - 0 through 0.8 in. w.g. External Static Pressure Range**

Heating Adjust CFM Selections	Heating Input Range and Blower Volume - CFM							
	35%	40%	50%	60%	70%	80%	90%	100%
Increase (+15%) Heat CFM	484	531	625	718	812	906	999	1093
Increase (+7.5%) Heat CFM	446	490	579	667	756	845	933	1022
Default Heat CFM	407	449	533	616	700	784	867	951
Decrease (-7.5% ) Heat CFM	377	413	487	561	635	709	783	857
Decrease (-15% ) Heat CFM	346	378	442	506	571	635	699	763

**COOLING BLOWER PERFORMANCE - 0 through 1.0 in. w.g. External Static Pressure Range**

Cooling Adjust CFM Selections	Blower Speed Selections							
	First Stage Cool Speed - cfm				Second Stage Cool Speed - cfm			
	Low	Medium-Low	Medium High	High (Default)	Low	Medium-Low	Medium High	High (Default)
Increase (+10%) Cool CFM	590	705	805	955	840	1050	1205	1355
Default Cool CFM	540	640	725	820	750	945	1130	1230
Decrease (-10%) Cool CFM	500	580	665	720	685	805	990	1110

The effect of static pressure is included in air volumes shown.

The following control configurations are available. See Installation Instructions for details and DIP switch settings.

**Heat Modes Available (Heating Blower Performance Table):**

Single stage thermostat:

- 35%, 70%, 100% input (three-stage) with time delays in-between.

Two-stage thermostat:

- Variable Rate Capacity Mode - furnace automatically adjusts firing rate based on first- and second-stage cycle times.
- W1 demand at 70% input, W2 demand at 100% input. No delay between stages.

**Cool Mode Available (Cooling Blower Performance table):**

First stage COOL (two-stage air conditioning units only) is approximately 70% of the same second stage COOL speed position.

Continuous Fan speeds are approximately 28% and 38% (DIP switch selectable) of the same second-stage COOL speed position. minimum 250 cfm.

Lennox iHarmony® Zoning System Applications - Minimum blower speed is 250 cfm.

## BLOWER DATA

### SLP99UH070XV36B BLOWER PERFORMANCE (less filter)

#### SINGLE SIDE RETURN AIR WITH OPTIONAL RETURN AIR BASE

#### HEATING BLOWER PERFORMANCE - 0 through 0.8 in. w.g. External Static Pressure Range

Heating Adjust CFM Selections	Heating Input Range and Blower Volume - CFM							
	35%	40%	50%	60%	70%	80%	90%	100%
Increase (+15%) Heat CFM	471	519	614	709	805	900	996	1091
Increase (+7.5%) Heat CFM	435	480	570	660	751	841	931	1021
Default Heat CFM	399	441	526	611	696	781	866	951
Decrease (-7.5%) Heat CFM	369	408	486	564	643	721	799	877
Decrease (-15%) Heat CFM	339	375	446	517	589	660	732	803

#### COOLING BLOWER PERFORMANCE - 0 through 1.0 in. w.g. External Static Pressure Range

Cooling Adjust CFM Selections	Blower Speed Selections							
	First Stage Cool Speed - cfm				Second Stage Cool Speed - cfm			
	Low	Medium-Low	Medium High	High (Default)	Low	Medium-Low	Medium High	High (Default)
Increase (+10%) Cool CFM	595	715	815	950	855	1045	1205	1350
Default Cool CFM	520	655	755	840	790	945	1090	1255
Decrease (-10%) Cool CFM	490	595	670	745	720	845	985	1130

The effect of static pressure is included in air volumes shown.

The following control configurations are available. See Installation Instructions for details and DIP switch settings.

#### Heat Modes Available (Heating Blower Performance Table):

Single stage thermostat:

- 35%, 70%, 100% input (three-stage) with time delays in-between.

Two-stage thermostat:

- Variable Rate Capacity Mode - furnace automatically adjusts firing rate based on first- and second-stage cycle times.
- W1 demand at 70% input, W2 demand at 100% input. No delay between stages.

#### Cool Mode Available (Cooling Blower Performance table):

First stage COOL (two-stage air conditioning units only) is approximately 70% of the same second stage COOL speed position.

Continuous Fan speeds are approximately 28% and 38% (DIP switch selectable) of the same second-stage COOL speed position. minimum 250 cfm.

Lennox iHarmony® Zoning System Applications - Minimum blower speed is 250 cfm.

## BLOWER DATA

### SLP99UH090XV36C BLOWER PERFORMANCE (less filter)

#### BOTTOM RETURN AIR

#### HEATING BLOWER PERFORMANCE - 0 through 0.8 in. w.g. External Static Pressure Range

Heating Adjust CFM Selections	Heating Input Range and Blower Volume - CFM							
	35%	40%	50%	60%	70%	80%	90%	100%
Increase (+15%) Heat CFM	687	734	827	921	1014	1108	1201	1295
Increase (+7.5%) Heat CFM	654	697	782	867	953	1038	1123	1209
Default Heat CFM	621	660	737	814	891	968	1045	1122
Decrease (-7.5%) Heat CFM	581	616	687	757	828	899	970	1041
Decrease (-15%) Heat CFM	540	572	637	701	766	830	895	959

#### COOLING BLOWER PERFORMANCE - 0 through 1.0 in. w.g. External Static Pressure Range

Cooling Adjust CFM Selections	Blower Speed Selections							
	First Stage Cool Speed - cfm				Second Stage Cool Speed - cfm			
	Low	Medium-Low	Medium High	High (Default)	Low	Medium-Low	Medium High	High (Default)
Increase (+10%) Cool CFM	625	710	830	950	875	1040	1210	1360
Default Cool CFM	565	670	760	860	800	945	1100	1240
Decrease (-10%) Cool CFM	520	610	685	785	720	840	970	1115

The effect of static pressure is included in air volumes shown.

The following control configurations are available. See Installation Instructions for details and DIP switch settings.

#### Heat Modes Available (Heating Blower Performance Table):

Single stage thermostat:

- 35%, 70%, 100% input (three-stage) with time delays in-between.

Two-stage thermostat:

- Variable Rate Capacity Mode - furnace automatically adjusts firing rate based on first- and second-stage cycle times.
- W1 demand at 70% input, W2 demand at 100% input. No delay between stages.

#### Cool Mode Available (Cooling Blower Performance table):

First stage COOL (two-stage air conditioning units only) is approximately 70% of the same second stage COOL speed position.

Continuous Fan speeds are approximately 28% and 38% (DIP switch selectable) of the same second-stage COOL speed position. minimum 250 cfm.

Lennox iHarmony® Zoning System Applications - Minimum blower speed is 250 cfm.

## BLOWER DATA

### SLP99UH090XV36C BLOWER PERFORMANCE (less filter)

#### SINGLE SIDE RETURN AIR

#### HEATING BLOWER PERFORMANCE - 0 through 0.8 in. w.g. External Static Pressure Range

Heating Adjust CFM Selections	Heating Input Range and Blower Volume - CFM							
	35%	40%	50%	60%	70%	80%	90%	100%
Increase (+15%) Heat CFM	657	702	792	881	971	1061	1150	1240
Increase (+7.5%) Heat CFM	631	673	757	841	926	1010	1094	1178
Default Heat CFM	605	644	723	802	880	959	1037	1116
Decrease (-7.5% ) Heat CFM	574	608	676	745	814	882	951	1020
Decrease (-15% ) Heat CFM	542	571	630	689	747	806	864	923

#### COOLING BLOWER PERFORMANCE - 0 through 1.0 in. w.g. External Static Pressure Range

Cooling Adjust CFM Selections	Blower Speed Selections							
	First Stage Cool Speed - cfm				Second Stage Cool Speed - cfm			
	Low	Medium-Low	Medium High	High (Default)	Low	Medium-Low	Medium High	High (Default)
Increase (+10%) Cool CFM	610	705	795	920	840	1015	1165	1300
Default Cool CFM	560	640	715	810	770	910	1050	1190
Decrease (-10%) Cool CFM	525	605	665	725	695	795	945	1110

The effect of static pressure is included in air volumes shown.

The following control configurations are available. See Installation Instructions for details and DIP switch settings.

#### Heat Modes Available (Heating Blower Performance Table):

Single stage thermostat:

- 35%, 70%, 100% input (three-stage) with time delays in-between.

Two-stage thermostat:

- Variable Rate Capacity Mode - furnace automatically adjusts firing rate based on first- and second-stage cycle times.
- W1 demand at 70% input, W2 demand at 100% input. No delay between stages.

#### Cool Mode Available (Cooling Blower Performance table):

First stage COOL (two-stage air conditioning units only) is approximately 70% of the same second stage COOL speed position.

Continuous Fan speeds are approximately 28% and 38% (DIP switch selectable) of the same second-stage COOL speed position. minimum 250 cfm.

Lennox iHarmony® Zoning System Applications - Minimum blower speed is 250 cfm.



## BLOWER DATA

### SLP99UH090XV36C BLOWER PERFORMANCE (less filter)

#### SINGLE SIDE RETURN AIR WITH OPTIONAL RETURN AIR BASE

#### HEATING BLOWER PERFORMANCE - 0 through 0.8 in. w.g. External Static Pressure Range

Heating Adjust CFM Selections	Heating Input Range and Blower Volume - CFM							
	35%	40%	50%	60%	70%	80%	90%	100%
Increase (+15%) Heat CFM	677	721	810	899	988	1076	1165	1254
Increase (+7.5%) Heat CFM	639	679	760	842	923	1004	1085	1167
Default Heat CFM	600	637	711	784	858	932	1005	1079
Decrease (-7.5%) Heat CFM	573	606	673	740	806	873	939	1006
Decrease (-15%) Heat CFM	546	576	635	695	754	814	873	933

#### COOLING BLOWER PERFORMANCE - 0 through 1.0 in. w.g. External Static Pressure Range

Cooling Adjust CFM Selections	Blower Speed Selections							
	First Stage Cool Speed - cfm				Second Stage Cool Speed - cfm			
	Low	Medium-Low	Medium High	High (Default)	Low	Medium-Low	Medium High	High (Default)
Increase (+10%) Cool CFM	605	715	810	930	850	995	1165	1305
Default Cool CFM	570	660	735	820	775	905	1050	1205
Decrease (-10%) Cool CFM	530	600	670	725	710	800	945	1070

The effect of static pressure is included in air volumes shown.

The following control configurations are available. See Installation Instructions for details and DIP switch settings.

#### Heat Modes Available (Heating Blower Performance Table):

Single stage thermostat:

- 35%, 70%, 100% input (three-stage) with time delays in-between.

Two-stage thermostat:

- Variable Rate Capacity Mode - furnace automatically adjusts firing rate based on first- and second-stage cycle times.
- W1 demand at 70% input, W2 demand at 100% input. No delay between stages.

#### Cool Mode Available (Cooling Blower Performance table):

First stage COOL (two-stage air conditioning units only) is approximately 70% of the same second stage COOL speed position.

Continuous Fan speeds are approximately 28% and 38% (DIP switch selectable) of the same second-stage COOL speed position. minimum 250 cfm.

Lennox iHarmony® Zoning System Applications - Minimum blower speed is 250 cfm.

## BLOWER DATA

### SLP99UH090XV48C BLOWER PERFORMANCE (less filter)

#### BOTTOM RETURN AIR

#### HEATING BLOWER PERFORMANCE - 0 through 0.8 in. w.g. External Static Pressure Range

Heating Adjust CFM Selections	Heating Input Range and Blower Volume - CFM							
	35%	40%	50%	60%	70%	80%	90%	100%
Increase (+15%) Heat CFM	769	835	968	1101	1234	1367	1500	1633
Increase (+7.5%) Heat CFM	713	776	902	1028	1155	1281	1407	1534
Default Heat CFM	656	716	836	955	1075	1195	1314	1434
Decrease (-7.5%) Heat CFM	595	652	767	882	997	1112	1227	1342
Decrease (-15%) Heat CFM	534	589	699	809	919	1029	1139	1249

#### COOLING BLOWER PERFORMANCE - 0 through 1.0 in. w.g. External Static Pressure Range

Cooling Adjust CFM Selections	Blower Speed Selections							
	First Stage Cool Speed - cfm				Second Stage Cool Speed - cfm			
	Low	Medium-Low	Medium High	High (Default)	Low	Medium-Low	Medium High	High (Default)
Increase (+10%) Cool CFM	840	1005	1155	1315	1165	1375	1580	1770
Default Cool CFM	780	915	1045	1190	1075	1265	1440	1645
Decrease (-10%) Cool CFM	690	835	955	1070	935	1145	1320	1465

The effect of static pressure is included in air volumes shown.

The following control configurations are available. See Installation Instructions for details and DIP switch settings.

#### Heat Modes Available (Heating Blower Performance Table):

Single stage thermostat:

- 35%, 70%, 100% input (three-stage) with time delays in-between.

Two-stage thermostat:

- Variable Rate Capacity Mode - furnace automatically adjusts firing rate based on first- and second-stage cycle times.
- W1 demand at 70% input, W2 demand at 100% input. No delay between stages.

#### Cool Mode Available (Cooling Blower Performance table):

First stage COOL (two-stage air conditioning units only) is approximately 70% of the same second stage COOL speed position.

Continuous Fan speeds are approximately 28% and 38% (DIP switch selectable) of the same second-stage COOL speed position. minimum 380 cfm.

Lennox iHarmony® Zoning System Applications - Minimum blower speed is 380 cfm.

## BLOWER DATA

### SLP99UH090XV48C BLOWER PERFORMANCE (less filter)

#### SINGLE SIDE RETURN AIR

#### HEATING BLOWER PERFORMANCE - 0 through 0.8 in. w.g. External Static Pressure Range

Heating Adjust CFM Selections	Heating Input Range and Blower Volume - CFM							
	35%	40%	50%	60%	70%	80%	90%	100%
Increase (+15%) Heat CFM	747	812	943	1073	1204	1334	1465	1595
Increase (+7.5%) Heat CFM	698	759	882	1005	1127	1250	1372	1495
Default Heat CFM	649	706	821	936	1051	1165	1280	1395
Decrease (-7.5%) Heat CFM	589	644	755	867	978	1089	1200	1312
Decrease (-15%) Heat CFM	528	582	690	797	905	1013	1120	1228

#### COOLING BLOWER PERFORMANCE - 0 through 1.0 in. w.g. External Static Pressure Range

Cooling Adjust CFM Selections	Blower Speed Selections							
	First Stage Cool Speed - cfm				Second Stage Cool Speed - cfm			
	Low	Medium-Low	Medium High	High (Default)	Low	Medium-Low	Medium High	High (Default)
Increase (+10%) Cool CFM	820	1005	1135	1290	1140	1340	1525	1725
Default Cool CFM	755	880	1025	1150	1040	1235	1395	1565
Decrease (-10%) Cool CFM	680	815	925	1065	910	1120	1275	1400

The effect of static pressure is included in air volumes shown.

The following control configurations are available. See Installation Instructions for details and DIP switch settings.

#### Heat Modes Available (Heating Blower Performance Table):

Single stage thermostat:

- 35%, 70%, 100% input (three-stage) with time delays in-between.

Two-stage thermostat:

- Variable Rate Capacity Mode - furnace automatically adjusts firing rate based on first- and second-stage cycle times.
- W1 demand at 70% input, W2 demand at 100% input. No delay between stages.

#### Cool Mode Available (Cooling Blower Performance table):

First stage COOL (two-stage air conditioning units only) is approximately 70% of the same second stage COOL speed position.

Continuous Fan speeds are approximately 28% and 38% (DIP switch selectable) of the same second-stage COOL speed position. minimum 3808 cfm.

Lennox iHarmony® Zoning System Applications - Minimum blower speed is 380 cfm.

## BLOWER DATA

### SLP99UH090XV48C BLOWER PERFORMANCE (less filter)

#### SINGLE SIDE RETURN AIR WITH OPTIONAL RETURN AIR BASE

#### HEATING BLOWER PERFORMANCE - 0 through 0.8 in. w.g. External Static Pressure Range

Heating Adjust CFM Selections	Heating Input Range and Blower Volume - CFM							
	35%	40%	50%	60%	70%	80%	90%	100%
Increase (+15%) Heat CFM	764	828	956	1084	1213	1341	1469	1597
Increase (+7.5%) Heat CFM	705	766	888	1010	1132	1255	1377	1499
Default Heat CFM	645	703	819	936	1052	1168	1285	1401
Decrease (-7.5%) Heat CFM	594	650	762	874	986	1099	1211	1323
Decrease (-15%) Heat CFM	542	596	704	812	921	1029	1137	1245

#### COOLING BLOWER PERFORMANCE - 0 through 1.0 in. w.g. External Static Pressure Range

Cooling Adjust CFM Selections	Blower Speed Selections							
	First Stage Cool Speed - cfm				Second Stage Cool Speed - cfm			
	Low	Medium-Low	Medium High	High (Default)	Low	Medium-Low	Medium High	High (Default)
Increase (+10%) Cool CFM	840	955	1120	1280	1160	1360	1530	1740
Default Cool CFM	775	910	1010	1170	1060	1240	1400	1590
Decrease (-10%) Cool CFM	695	815	930	1045	925	1130	1295	1440

The effect of static pressure is included in air volumes shown.

The following control configurations are available. See Installation Instructions for details and DIP switch settings.

#### Heat Modes Available (Heating Blower Performance Table):

Single stage thermostat:

- 35%, 70%, 100% input (three-stage) with time delays in-between.

Two-stage thermostat:

- Variable Rate Capacity Mode - furnace automatically adjusts firing rate based on first- and second-stage cycle times.
- W1 demand at 70% input, W2 demand at 100% input. No delay between stages.

#### Cool Mode Available (Cooling Blower Performance table):

First stage COOL (two-stage air conditioning units only) is approximately 70% of the same second stage COOL speed position.

Continuous Fan speeds are approximately 28% and 38% (DIP switch selectable) of the same second-stage COOL speed position. minimum 380 cfm.

Lennox iHarmony® Zoning System Applications - Minimum blower speed is 380 cfm.

## BLOWER DATA

### SLP99UH090XV60C BLOWER PERFORMANCE (less filter)

#### BOTTOM RETURN AIR

#### HEATING BLOWER PERFORMANCE - 0 through 0.8 in. w.g. External Static Pressure Range

Heating Adjust CFM Selections	Heating Input Range and Blower Volume - CFM							
	35%	40%	50%	60%	70%	80%	90%	100%
Increase (+15%) Heat CFM	583	665	830	995	1159	1324	1488	1653
Increase (+7.5%) Heat CFM	540	618	774	930	1085	1241	1397	1553
Default Heat CFM	497	571	718	865	1012	1159	1306	1453
Decrease (-7.5% ) Heat CFM	439	507	644	781	917	1054	1191	1328
Decrease (-15% ) Heat CFM	380	443	570	697	823	950	1076	1203

#### COOLING BLOWER PERFORMANCE - 0 through 1.0 in. w.g. External Static Pressure Range

Cooling Adjust CFM Selections	Blower Speed Selections							
	First Stage Cool Speed - cfm				Second Stage Cool Speed - cfm			
	Low	Medium-Low	Medium High	High (Default)	Low	Medium-Low	Medium High	High (Default)
Increase (+10%) Cool CFM	1050	1270	1445	1620	1590	1815	2010	2195
Default Cool CFM	975	1120	1295	1460	1460	1645	1845	2010
Decrease (-10%) Cool CFM	865	1010	1120	1290	1320	1500	1645	1860

The effect of static pressure is included in air volumes shown.

The following control configurations are available. See Installation Instructions for details and DIP switch settings.

#### Heat Modes Available (Heating Blower Performance Table):

Single stage thermostat:

- 35%, 70%, 100% input (three-stage) with time delays in-between.

Two-stage thermostat:

- Variable Rate Capacity Mode - furnace automatically adjusts firing rate based on first- and second-stage cycle times.
- W1 demand at 70% input, W2 demand at 100% input. No delay between stages.

#### Cool Mode Available (Cooling Blower Performance table):

First stage COOL (two-stage air conditioning units only) is approximately 70% of the same second stage COOL speed position.

Continuous Fan speeds are approximately 28% and 38% (DIP switch selectable) of the same second-stage COOL speed position. minimum 380 cfm.

Lennox iHarmony® Zoning System Applications - Minimum blower speed is 450 cfm.

## BLOWER DATA

### SLP99UH090XV60C BLOWER PERFORMANCE (less filter)

**SINGLE SIDE RETURN AIR** – Air volumes in **bold** require Optional Return Air Base and field fabricated transition to accommodate 20 x 25 x 1 in. air filter in order to maintain proper air velocity.

#### HEATING BLOWER PERFORMANCE - 0 through 0.8 in. w.g. External Static Pressure Range

Heating Adjust CFM Selections	Heating Input Range and Blower Volume - CFM							
	35%	40%	50%	60%	70%	80%	90%	100%
Increase (+15%) Heat CFM	609	684	835	986	1136	1287	1437	1588
Increase (+7.5%) Heat CFM	551	623	769	914	1059	1205	1350	1496
Default Heat CFM	492	562	702	842	983	1123	1263	1403
Decrease (-7.5%) Heat CFM	436	502	633	765	896	1028	1159	1291
Decrease (-15%) Heat CFM	380	441	564	687	810	932	1055	1178

#### COOLING BLOWER PERFORMANCE - 0 through 1.0 in. w.g. External Static Pressure Range

Cooling Adjust CFM Selections	Blower Speed Selections							
	First Stage Cool Speed - cfm				Second Stage Cool Speed - cfm			
	Low	Medium-Low	Medium High	High (Default)	Low	Medium-Low	Medium High	High (Default)
Increase (+10%) Cool CFM	1040	1225	1380	1550	1555	1715	<b>1920</b>	<b>2135</b>
Default Cool CFM	960	1085	1225	1415	1430	1565	1790	<b>1980</b>
Decrease (-10%) Cool CFM	840	990	1085	1250	1280	1450	1580	1790

The effect of static pressure is included in air volumes shown.

The following control configurations are available. See Installation Instructions for details and DIP switch settings.

#### Heat Modes Available (Heating Blower Performance Table):

Single stage thermostat:

- 35%, 70%, 100% input (three-stage) with time delays in-between.

Two-stage thermostat:

- Variable Rate Capacity Mode - furnace automatically adjusts firing rate based on first- and second-stage cycle times.
- W1 demand at 70% input, W2 demand at 100% input. No delay between stages.

#### Cool Mode Available (Cooling Blower Performance table):

First stage COOL (two-stage air conditioning units only) is approximately 70% of the same second stage COOL speed position.

Continuous Fan speeds are approximately 28% and 38% (DIP switch selectable) of the same second-stage COOL speed position. minimum 380 cfm.

Lennox iHarmony® Zoning System Applications - Minimum blower speed is 450 cfm.

## BLOWER DATA

### SLP99UH110XV60C BLOWER PERFORMANCE (less filter)

#### BOTTOM RETURN AIR

#### HEATING BLOWER PERFORMANCE - 0 through 0.8 in. w.g. External Static Pressure Range

Heating Adjust CFM Selections	Heating Input Range and Blower Volume - CFM							
	35%	40%	50%	60%	70%	80%	90%	100%
Increase (+15%) Heat CFM	767	861	1049	1237	1424	1612	1800	1988
Increase (+7.5%) Heat CFM	738	825	1000	1174	1349	1524	1699	1874
Default Heat CFM	708	789	951	1112	1274	1436	1597	1759
Decrease (-7.5%) Heat CFM	655	731	883	1035	1187	1339	1491	1644
Decrease (-15%) Heat CFM	602	673	816	958	1101	1243	1386	1528

#### COOLING BLOWER PERFORMANCE - 0 through 1.0 in. w.g. External Static Pressure Range

Cooling Adjust CFM Selections	Blower Speed Selections							
	First Stage Cool Speed - cfm				Second Stage Cool Speed - cfm			
	Low	Medium-Low	Medium High	High (Default)	Low	Medium-Low	Medium High	High (Default)
Increase (+10%) Cool CFM	1060	1245	1345	1545	1560	1740	1930	2125
Default Cool CFM	970	1145	1265	1395	1405	1565	1775	1945
Decrease (-10%) Cool CFM	885	1025	1110	1250	1270	1425	1610	1770

The effect of static pressure is included in air volumes shown.

The following control configurations are available. See Installation Instructions for details and DIP switch settings.

#### Heat Modes Available (Heating Blower Performance Table):

Single stage thermostat:

- 35%, 70%, 100% input (three-stage) with time delays in-between.

Two-stage thermostat:

- Variable Rate Capacity Mode - furnace automatically adjusts firing rate based on first- and second-stage cycle times.
- W1 demand at 70% input, W2 demand at 100% input. No delay between stages.

#### Cool Mode Available (Cooling Blower Performance table):

First stage COOL (two-stage air conditioning units only) is approximately 70% of the same second stage COOL speed position.

Continuous Fan speeds are approximately 28% and 38% (DIP switch selectable) of the same second-stage COOL speed position. minimum 380 cfm.

Lennox iHarmony® Zoning System Applications - Minimum blower speed is 450 cfm.

## BLOWER DATA

### SLP99UH110XV60C BLOWER PERFORMANCE (less filter)

**SINGLE SIDE RETURN AIR** – Air volumes in **bold** require Optional Return Air Base and field fabricated transition to accommodate 20 x 25 x 1 in. air filter in order to maintain proper air velocity.

#### HEATING BLOWER PERFORMANCE - 0 through 0.8 in. w.g. External Static Pressure Range

Heating Adjust CFM Selections	Heating Input Range and Blower Volume - CFM							
	35%	40%	50%	60%	70%	80%	90%	100%
Increase (+15%) Heat CFM	733	825	1009	1194	1378	1562	1747	<b>1931</b>
Increase (+7.5%) Heat CFM	708	794	967	1139	1312	1484	1657	<b>1829</b>
Default Heat CFM	683	763	924	1085	1245	1406	1566	1727
Decrease (-7.5%) Heat CFM	632	707	857	1007	1157	1307	1457	1608
Decrease (-15%) Heat CFM	580	650	790	929	1069	1209	1348	1488

#### COOLING BLOWER PERFORMANCE - 0 through 1.0 in. w.g. External Static Pressure Range

Cooling Adjust CFM Selections	Blower Speed Selections							
	First Stage Cool Speed - cfm				Second Stage Cool Speed - cfm			
	Low	Medium-Low	Medium High	High (Default)	Low	Medium-Low	Medium High	High (Default)
Increase (+10%) Cool CFM	1050	1195	1315	1495	1515	1710	<b>1870</b>	<b>2065</b>
Default Cool CFM	960	1095	1220	1355	1360	1555	1755	<b>1890</b>
Decrease (-10%) Cool CFM	850	985	1095	1220	1215	1400	1555	1755

The effect of static pressure is included in air volumes shown.

The following control configurations are available. See Installation Instructions for details and DIP switch settings.

#### Heat Modes Available (Heating Blower Performance Table):

Single stage thermostat:

- 35%, 70%, 100% input (three-stage) with time delays in-between.

Two-stage thermostat:

- Variable Rate Capacity Mode - furnace automatically adjusts firing rate based on first- and second-stage cycle times.
- W1 demand at 70% input, W2 demand at 100% input. No delay between stages.

#### Cool Mode Available (Cooling Blower Performance table):

First stage COOL (two-stage air conditioning units only) is approximately 70% of the same second stage COOL speed position.

Continuous Fan speeds are approximately 28% and 38% (DIP switch selectable) of the same second-stage COOL speed position. minimum 380 cfm.

Lennox iHarmony® Zoning System Applications - Minimum blower speed is 450 cfm.



## BLOWER DATA

### SLP99UH135XV60D BLOWER PERFORMANCE (less filter)

#### BOTTOM RETURN AIR

#### HEATING BLOWER PERFORMANCE - 0 through 0.8 in. w.g. External Static Pressure Range

Heating Adjust CFM Selections	Heating Input Range and Blower Volume - CFM							
	35%	40%	50%	60%	70%	80%	90%	100%
Increase (+15%) Heat CFM	949	1033	1200	1367	1534	1701	1868	2035
Increase (+7.5%) Heat CFM	879	957	1113	1269	1426	1582	1738	1895
Default Heat CFM	808	881	1026	1172	1317	1463	1608	1754
Decrease (-7.5%) Heat CFM	748	817	956	1095	1235	1374	1513	1652
Decrease (-15%) Heat CFM	687	753	886	1019	1152	1284	1417	1550

#### COOLING BLOWER PERFORMANCE - 0 through 1.0 in. w.g. External Static Pressure Range

Cooling Adjust CFM Selections	Blower Speed Selections							
	First Stage Cool Speed - cfm				Second Stage Cool Speed - cfm			
	Low	Medium-Low	Medium High	High (Default)	Low	Medium-Low	Medium High	High (Default)
Increase (+10%) Cool CFM	1070	1260	1410	1555	1565	1750	1970	2190
Default Cool CFM	980	1115	1255	1430	1445	1615	1805	1985
Decrease (-10%) Cool CFM	865	1020	1115	1280	1290	1470	1650	1805

The effect of static pressure is included in air volumes shown.

The following control configurations are available. See Installation Instructions for details and DIP switch settings.

#### Heat Modes Available (Heating Blower Performance Table):

Single stage thermostat:

- 35%, 70%, 100% input (three-stage) with time delays in-between.

Two-stage thermostat:

- Variable Rate Capacity Mode - furnace automatically adjusts firing rate based on first- and second-stage cycle times.
- W1 demand at 70% input, W2 demand at 100% input. No delay between stages.

#### Cool Mode Available (Cooling Blower Performance table):

First stage COOL (two-stage air conditioning units only) is approximately 70% of the same second stage COOL speed position.

Continuous Fan speeds are approximately 28% and 38% (DIP switch selectable) of the same second-stage COOL speed position. minimum 380 cfm.

Lennox iHarmony® Zoning System Applications - Minimum blower speed is 450 cfm.

## BLOWER DATA

### SLP99UH135XV60D BLOWER PERFORMANCE (less filter)

**SINGLE SIDE RETURN AIR** – Air volumes in **bold** require Optional Return Air Base and field fabricated transition to accommodate 20 x 25 x 1 in. air filter in order to maintain proper air velocity.

### HEATING BLOWER PERFORMANCE - 0 through 0.8 in. w.g. External Static Pressure Range

Heating Adjust CFM Selections	Heating Input Range and Blower Volume - CFM							
	35%	40%	50%	60%	70%	80%	90%	100%
Increase (+15%) Heat CFM	927	1010	1175	1340	1505	1671	<b>1836</b>	<b>2001</b>
Increase (+7.5%) Heat CFM	844	923	1081	1239	1398	1556	1714	<b>1873</b>
Default Heat CFM	760	836	987	1138	1290	1441	1593	1744
Decrease (-7.5%) Heat CFM	703	775	919	1064	1208	1352	1496	1641
Decrease (-15%) Heat CFM	646	715	852	989	1126	1263	1400	1537

### COOLING BLOWER PERFORMANCE - 0 through 1.0 in. w.g. External Static Pressure Range

Cooling Adjust CFM Selections	Blower Speed Selections							
	First Stage Cool Speed - cfm				Second Stage Cool Speed - cfm			
	Low	Medium-Low	Medium High	High (Default)	Low	Medium-Low	Medium High	High (Default)
Increase (+10%) Cool CFM	1070	1235	1385	1535	1550	1720	<b>1925</b>	<b>2005</b>
Default Cool CFM	985	1110	1245	1395	1415	1605	1755	<b>1970</b>
Decrease (-10%) Cool CFM	870	1010	1110	1260	1280	1435	1610	1755

The effect of static pressure is included in air volumes shown.

The following control configurations are available. See Installation Instructions for details and DIP switch settings.

#### Heat Modes Available (Heating Blower Performance Table):

Single stage thermostat:

- 35%, 70%, 100% input (three-stage) with time delays in-between.

Two-stage thermostat:

- Variable Rate Capacity Mode - furnace automatically adjusts firing rate based on first- and second-stage cycle times.
- W1 demand at 70% input, W2 demand at 100% input. No delay between stages.

#### Cool Mode Available (Cooling Blower Performance table):

First stage COOL (two-stage air conditioning units only) is approximately 70% of the same second stage COOL speed position.

Continuous Fan speeds are approximately 28% and 38% (DIP switch selectable) of the same second-stage COOL speed position. minimum 380 cfm.

Lennox iHarmony® Zoning System Applications - Minimum blower speed is 450 cfm.

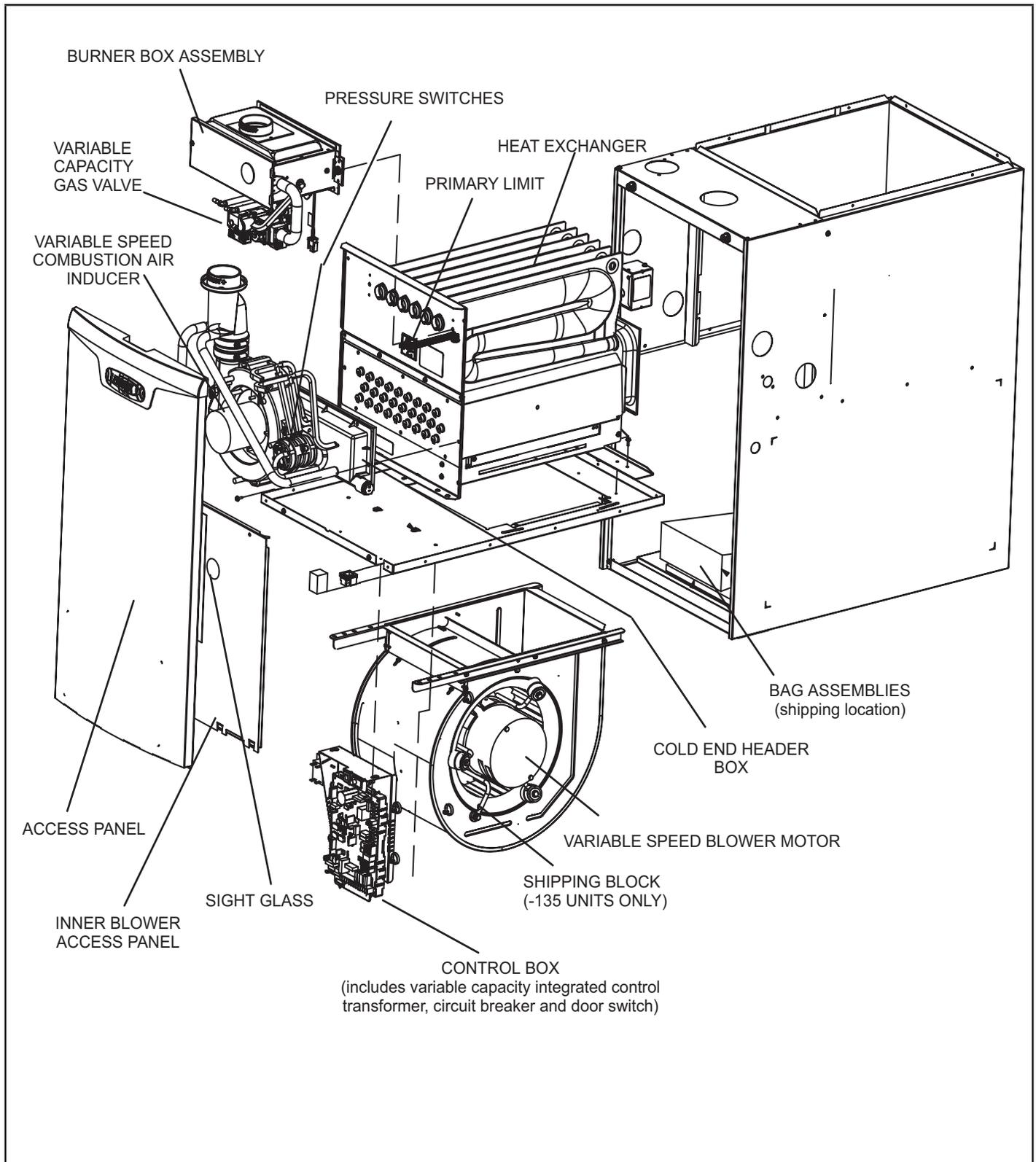

**FIGURE 1**

## I-UNIT COMPONENTS

SLP99UHV unit components are shown in FIGURE 1. The gas valve, combustion air inducer and burners can be accessed by removing the access panel. Electrical components are in the control box (FIGURE 2) found in the blower compartment. SLP99UHV units are factory-equipped with a bottom return air panel in place. The panel is designed to be field removed as required for bottom air return. Markings are provided for side return air and may be cut out in the field.

<b>ELECTROSTATIC DISCHARGE (ESD)</b> Precautions and Procedures	
<b>⚠ CAUTION</b>	
	<b>Electrostatic discharge can affect electronic components. Take precautions to neutralize electrostatic charge by touching your hand and tools to metal prior to handling the control.</b>

### A-Control Box

#### 1. Control Transformer (T1)

A transformer located in the control box provides power to the low voltage section of the unit. Transformers on all models are rated 40VA with a 120V primary and a 24V secondary.

#### 2. Interlock Switch (S51)

An interlock switch rated 14A at 125VAC is wired in series with line voltage. When the inner blower access panel is removed the unit will shut down.

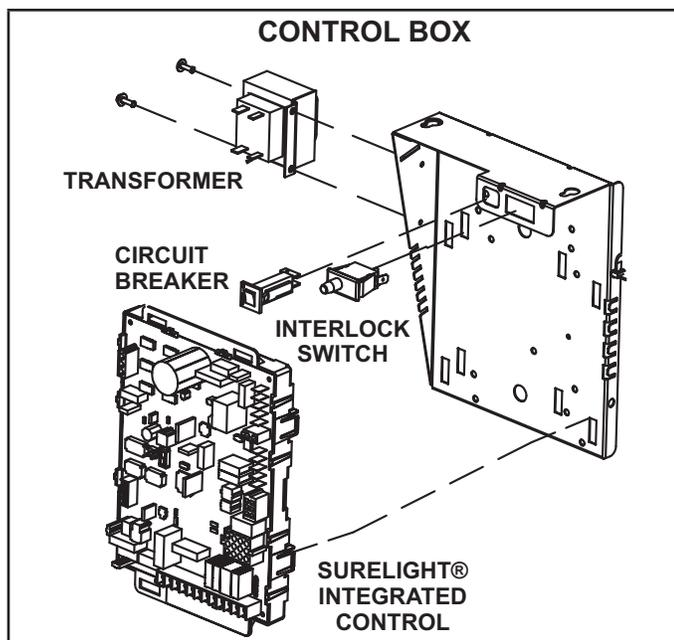

FIGURE 2

#### 3. Circuit Breaker (CB8)

A 24V circuit breaker is also located in the control box. The switch provides overcurrent protection to the transformer (T1). The breaker is rated 3A at 32V. If the current exceeds this limit the breaker will trip and all unit operation will shut down. The breaker can be manually reset by pressing the button on the face. See FIGURE 3.

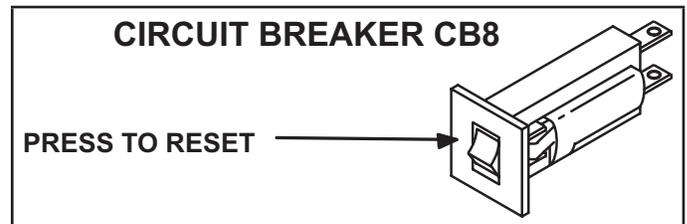

FIGURE 3

<b>⚠ WARNING</b>	
	<b>Shock hazard. Disconnect power before servicing. Integrated control is not field repairable. If control is inoperable, simply replace entire control. Can cause injury or death. Unsafe operation will result if repair is attempted.</b>

#### 4. Integrated Control (A92)

SLP99UHV units are equipped with the Lennox SureLight® variable-capacity integrated control. This control can be used with the icomfort Wi-Fi® thermostat as part of a communicating comfort system. The control can also operate with a conventional single or two-stage thermostat. The system consists of an ignition / blower control (FIGURE 4 and FIGURE 5) with control pin designations in TABLE 1 and TABLE 2, and ignitor.

The control provides gas ignition, safety checks and indoor blower control with variable capacity rate gas heating. The furnace combustion air inducer, gas valve and indoor blower are controlled in response to various system inputs such as thermostat signal, pressure and limit switch signal and flame signal. The control features a seven-segment LED display, indicating furnace status (including indoor blower) and error codes. The LED flashes in single digits. For example using table 14 under LIMIT CODE, an "E" followed by "2" followed by "5" followed by "0", the limit switch circuit is open. The control also has two 120 volt accessory terminals (used for a humidifier and electronic air cleaner) rated at (1) one amp each.

## Electronic Ignition

At the beginning of the heat cycle the SureLight® integrated control monitors the low fire combustion air inducer pressure switch. The control will not begin the heating cycle if the low fire pressure switch is closed (by-passed). Likewise the control will not begin the high fire heating cycle if the high fire pressure switch is closed, and will remain in low fire heat. However, if the high fire pressure switch closes during the low fire heat pre-purge, the control will allow high fire heat. Once the low fire pressure switch is determined to be open, the combustion air inducer is energized on ignition speed.

When the differential in the pressure switch is great enough, the pressure switch closes and a 15-second pre-purge begins. If the switch is not proven within 2-1/2 minutes, the inducer is de-energized and the control will initiate vent calibration. If the vent calibration is unsuccessful the control goes into a 5 minute delay. The control will attempt vent calibration 3 more times before going into a 1 hour soft lockout.

After the 15 second pre-purge period the SureLight ignitor warms up for 20 seconds. The gas valve then opens for a 4-second trial for ignition. The ignitor stays energized during this trial until flame is sensed. If ignition is not proven during the 4-second trial for ignition, the control will try four more times with an inter purge and warm-up time between trials of 35 seconds. After a total of five trials for ignition (including the initial trial), the control goes into Watchguard- Flame Failure mode. After a 60-minute reset period, the control will begin the ignition sequence again.

### Thermostat Selection Modes

See table 3 for DIP switch settings

The control can be made to operate in three modes: variable capacity, three-stage timed or two-stage. The variable capacity and two-stage modes are only operational with a two-stage thermostat. The thermostat selection is made using dip switches one and / or two (FIGURE 4) and must be positioned for the particular application.

### Variable Capacity

Using a two-stage thermostat the system will operate in a variable capacity sequence mode. In this mode, the control will vary the firing rate anywhere between 35% and 100% of full capacity. The indoor blower will be automatically adjusted accordingly to provide the appropriate air-flow at any rate. On the initial call for low fire, the furnace will operate at 35% and will remain there until the heat call is satisfied or a call for high fire is initiated. If there is a call for high fire the rate will increase by 10% if the current rate is above 60%. However, if the current rate is below 60% the rate will increase to 70%. After this initial rate increase to 70% capacity, the furnace will increase rate by 10% every 5 minutes while a high fire heat call is present. If the high fire heat call is satisfied but the low fire heat call is still present, the furnace will remain at the current firing rate until the demand is satisfied or another call for high fire is initiated.

## Three-Stage Timed Operation

Using a single-stage thermostat the system will operate in a three stage timed mode. Upon a call for heat and a successful ignition, the combustion air inducer will operate at 35% and the indoor blower will adjust to the appropriate cfm. After a field selectable 7 or 12 minute delay period, the inducer RPM will increase and the unit will operate at 70%. The indoor blower will adjust to the appropriate cfm. After a factory set non-adjustable 10 minute delay expires the furnace will increase rate to 100%. The indoor blower will adjust to the appropriate cfm.

### Two-Stage Operation

The system will also operate in conventional two-stage mode. While in two-stage mode, the furnace will fire on low fire (70% rate). The combustion air inducer will operate at 70% and the indoor blower will adjust to the appropriate cfm. The unit will switch to high fire on a W2 call from the thermostat. After a 30 second recognition period (during which the integrated control will receive a continuous W2 call) expires the furnace will increase to 100% rate. The inducer will increase to 100% speed and the indoor blower will adjust to appropriate cfm. If there is a simultaneous call for first and second stage heat, the unit will fire on first stage heat and switch to second stage heat after 30 seconds of operation.

TABLE 1

SureLight® Control 6 Pin Terminal Designation	
Pin #	Function
1	Data Input From Motor
2	Common
3	Not Used
4	Data Output To Motor
5	5 Volt Bias Supply
6	Not Used

TABLE 2

SureLight Control 12 Pin Terminal Designation	
Pin #	Function
1	Not used
2	High Fire Pressure Switch
3	Rollout In
4	Ground
5	24V Hot
6	Primary Limit In
7	Gas Valve
8	Gas Valve Common
9	24V Neutral
10	Ground
11	Primary Limit Switch Out
12	Low Fire Pressure Switch

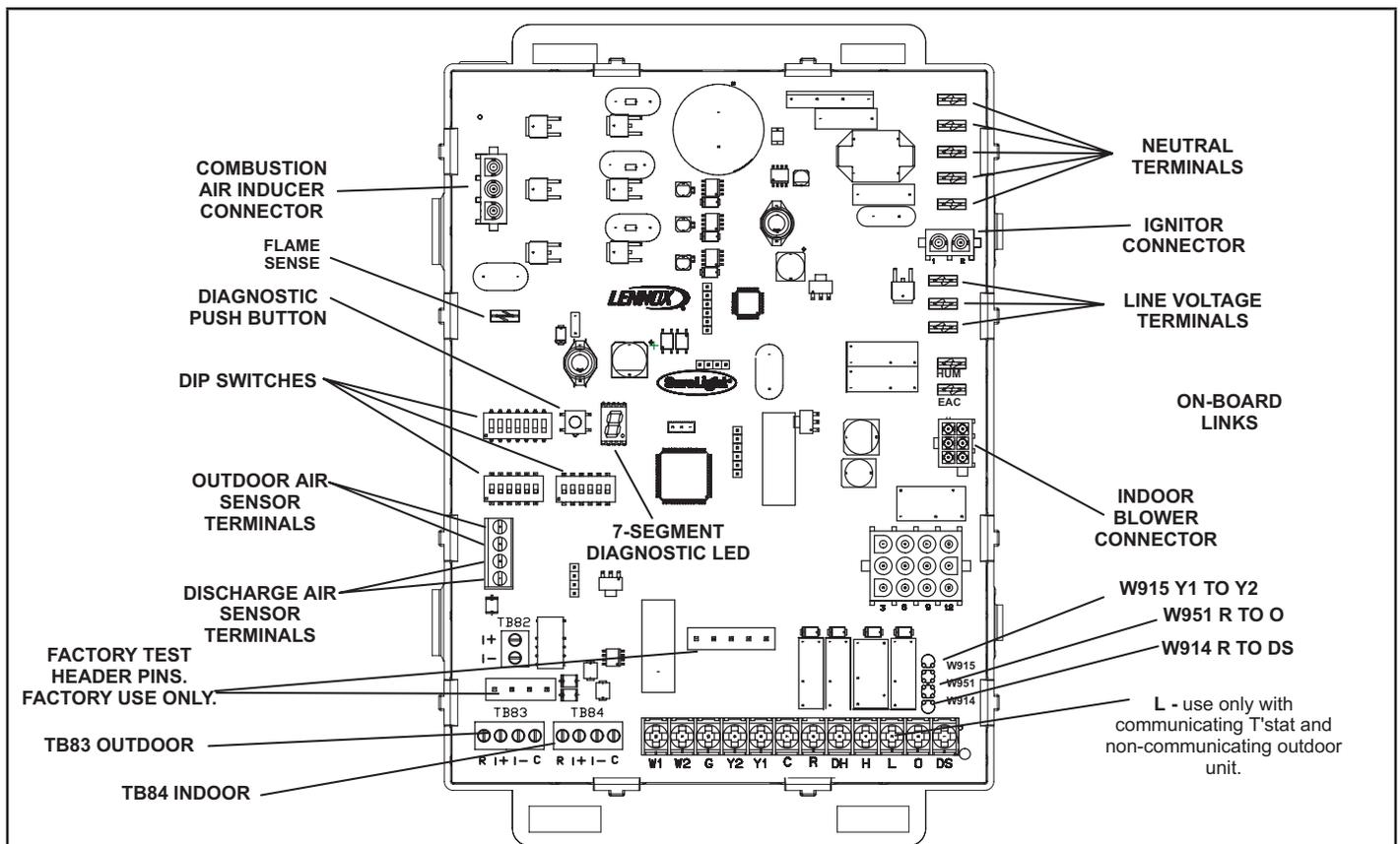

**RS-BUS LINK (TB82, future use)**

I+ = DATA HIGH CONNECTION  
I- = DATA LOW CONNECTION

**RS-BUS OUTDOOR (TB83)**

R = 24VAC  
I+ = DATA HIGH CONNECTION  
I- = DATA LOW CONNECTION  
C = 24VAXC COMMON

**RS-BUS INDOOR (TB84)**

R = 24VAC  
I+ = DATA HIGH CONNECTION  
I- = DATA LOW CONNECTION  
C = 24VAXC COMMON

**1/4" QUICK CONNECT TERMINALS**

HUM = 120 VAC OUTPUT TO HUMIDIFIER  
XMFR = 120 VAC OUTPUT TO TRANSFORMER  
LI = 120 VAC INPUT TO CONTROL  
CIRC = 120 VAC OUTPUT TO CIRCULATING BLOWER  
EAC = 120 VAC OUTPUT TO ELECTRICAL AIR CLEANER  
NEUTRALS = 120 VAC NEUTRAL

**THERMOSTAT CONNECTIONS (TB1)**

DS = DEHUMIDIFICATION SIGNAL  
W2 = HEAT DEMAND FROM 2ND STAGE T/STAT  
W1 = HEAT DEMAND FROM 1ST STAGE T/STAT  
R = CLASS 2 VOLTAGE TO THERMOSTAT  
G = MANUAL FAN FROM T'STAT  
C = THERMOSTAT SIGNAL GROUND CONNECTED TO TRANSFORMER GRD (TR) & CHASIS GROUND (GRD)  
Y1 = THERMOSTAT 1ST STAGE COOL SIGNAL  
Y2 = THERMOSTAT 2ND STAGE COOL SIGNAL  
O = THERMOSTAT SIGNAL TO HEAT PUMP REVERSING VALVE  
H = 24V HUMIDIFIER OUTPUT. DO NOT CONNECT TO COMFORTSENSE® THERMOSTAT  
L = USE ONLY WITH A COMMUNICATING THERMOSTAT AND A NON-COMMUNICATING OUTDOOR UNIT  
DH = DEHUMIDIFICATION OUTPUT COMMUNICATING THERMOSTAT ONLY

**FIGURE 4**

# SLP99UHV INTEGRATED CONTROL CONFIGURATION GUIDE

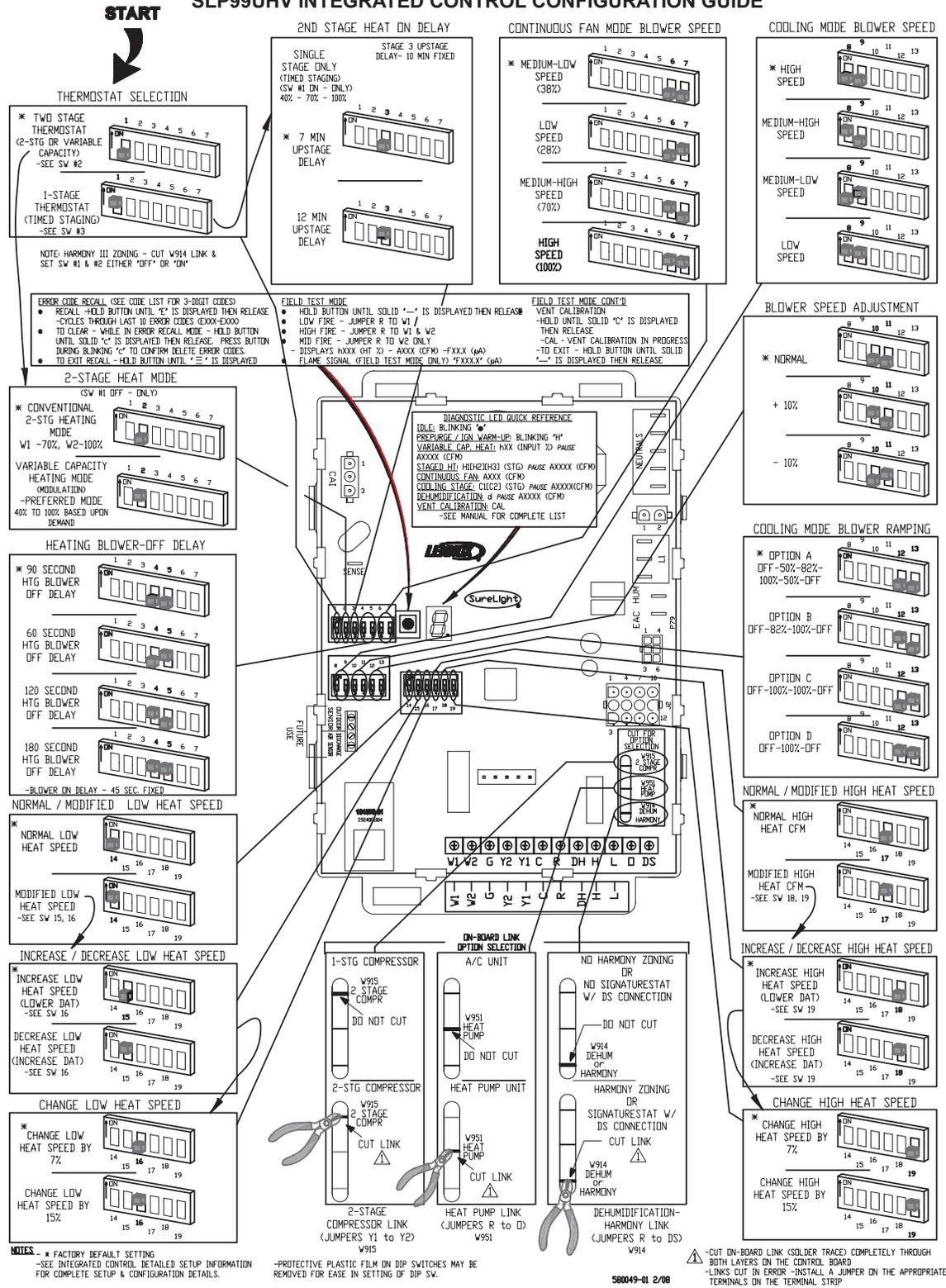

FIGURE 5

**TABLE 3**

**Thermostat Selection Switch Settings**

Operation	Thermostat	Switch 1	Switch 2	Switch 3
Variable Capacity Heat (35% to 100%)	Two-Stage	Off	On	Off
Three-Stage Heat (35%, 70%, 100%)	Single-Stage	On	Off	2nd stage delay OFF = 7 minutes ON = 12 minutes 3rd stage delay 10 minutes fixed
Two-Stage Heat (W1 70%, W2 100%)	Two-Stage	Off	Off	Off

**NOTE** - When the SLP99UHV is used with a communicating thermostat, all indoor blower speed selections and DIP switch settings are made by the thermostat.

**NOTE** - All DIP switches are factory shipped in the "OFF" position.

**Heating Operation DIP Switch Settings -- Figure 4 Switch 1 -- Thermostat Selection** -- This unit may be used with either a single-stage or two-stage thermostat. The thermostat selection is made using a DIP switch which must be properly positioned for the particular application. The DIP switch is factory-positioned for use with a two-stage thermostat. If a single-stage thermostat is to be used, the DIP switch must be repositioned. See table 3.

**Switch 2 -- Operating Mode with Two-Stage Thermostat** -- If a two-stage thermostat is used, the furnace can operate in either variable-capacity or conventional two-stage mode. When variable-capacity mode is selected, the firing rate of the unit is varied to maximize comfort. Conventional two-stage mode is the factory default setting. See table 3.

**Switch 3 -- Second-Stage Heat On Delay** -- If a single-stage thermostat is used, the integrated control can be used to energize second-stage heat after either 7 minutes or 12 minutes of first-stage heat operation. See table 3.

**Switches 4 and 5 -- Blower-Off Delay** -- The blower-on delay of 45 seconds is not adjustable. The blower-off delay (time that the blower operates after the heating demand has been satisfied) can be adjusted by moving switches 4 and 5 on the integrated control. The unit is shipped from the factory with a blower-off delay of 120 seconds. The blower off delay affects comfort and is adjustable to satisfy individual applications. Adjust the blower off delay to achieve a supply air temperature between 90° and 110°F at the exact moment that the blower is de-energized. Longer off delay settings provide lower supply air temperatures; shorter settings provide higher supply air temperatures. TABLE 4 provides the blower-off timings that will result from different switch settings.

**TABLE 4**

**Blower-Off Delay Switch Settings**

Blower-Off Delay (Seconds)	Switch 4	Switch 5
90	Off	On
120 (factory)	Off	Off
180	On	Off
210	On	On

**Indoor Blower Operation DIP Switch Settings**

**Switches 6 and 7 -- Continuous Indoor Fan Operation Blower Speed** -- The unit is shipped from the factory with the DIP switches positioned for medium low (2) speed during continuous indoor blower operation. TABLE 5 provides the continuous blower speeds that will result from different switch settings. Refer to blower tables at the front of this manual for corresponding cfm values.

**TABLE 5**

**Continuous Indoor Blower Operation -- Blower Speeds**

Speed	Switch 6	Switch 7
1 - Low (28%)*	Off	On
2 - Medium Low (38%)* Factory	Off	Off

**Switches 8 and 9 -- Cooling Mode Blower Speed --**

Switches 8 and 9 are used to select cooling blower motor speed. The unit is shipped from the factory with the DIP switches positioned for high speed (4) indoor blower motor operation during the cooling mode. TABLE 6 provides the cooling mode blower speeds that will result from different switch settings. Refer to blower tables at the front of this manual for corresponding cfm values.

**TABLE 6**

**Cooling Mode Blower Speeds**

Speed	Switch 8	Switch 9
1 - Low	On	On
2 - Medium Low	Off	On
3 - Medium High	On	Off
4 - High Factory	Off	Off



**Switches 10 and 11 -- Cooling Mode Blower Speed Adjustment** -- Switches 10 and 11 are used to select blower speed adjustment settings. The unit is shipped from the factory with the DIP switches positioned for NORMAL (no) adjustment. The DIP switches may be positioned to adjust the blower speed by +10% or -10% to better suit the application.

TABLE 7 provides blower speed adjustments that will result from different switch settings. Refer to blower tables at the front of this manual for corresponding cfm values. With switches 10 and 11 set to ON, motor will bypass ramping profiles and all delays and immediately upon a call for cool, run at COOLING speed selected. LED will continue to operate as normal. This mode is used to check motor operation.

**TABLE 7**

**Cooling Mode Blower Speed Adjustment**

Adjustment	Switch 10	Switch 11
+10% (approx.)	On	Off
Default Cool CFM	Off	Off
-10% (approx.)	Off	On
Motor Test	On	On

**Switches 12 and 13 -- Cooling Mode Blower Speed Ramping** - Switches 12 and 13 are used to select cooling mode blower speed ramping options. Blower speed ramping may be used to enhance dehumidification performance. The switches are factory set at option A which has the greatest effect on blower motor performance. TABLE 8 provides the cooling mode blower speed ramping options that will result from different switch settings. The cooling mode blower speed ramping options are detailed below.

**TABLE 8**

**Cooling Mode Blower Speed Ramping**

Ramping Option	Switch 12	Switch 13
A (factory)	Off	Off
B	On	Off
C	Off	On
D	On	On

**Ramping Option A (Factory Selection)**

- Motor runs at 50% for 30 seconds.
- Motor then runs at 82% for approximately 7-1/2 minutes.
- If demand has not been satisfied after 7-1/2 minutes, motor runs at 100% until demand is satisfied.
- Once demand is met, motor runs at 50% for 30 seconds then ramps down to stop.

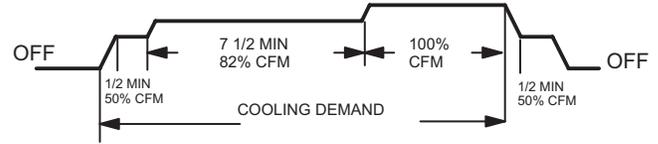

**Ramping Option B**

- Motor runs at 82% for approximately 7-1/2 minutes. If demand has not been satisfied after 7-1/2 minutes, motor runs at 100% until demand is satisfied.
- Once demand is met, motor ramps down to stop.



**Ramping Option C**

- Motor runs at 100% until demand is satisfied.
- Once demand is met, motor runs at 100% for 45 seconds then ramps down to stop.



**Ramping Option D**

- Motor runs at 100% until demand is satisfied.
- Once demand is met, motor ramps down to stop.

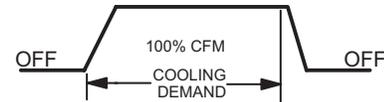

**TABLE 9**

**Low Heat Blower Speeds**

Thermostat Demand	Blower Speed Adjustments	DIP Switch Settings		
		14	15	16
Low Heat (R to W1)	+ 15%	On	Off	On
	+ 7.5%	On	Off	Off
	Normal	Off	Off	Off
	- 7.5%	On	On	Off
	- 15%	On	On	On

**TABLE 10**

**High Heat Blower Speeds**

Thermostat Demand	Blower Speed Adjustments	DIP Switch Settings		
		17	18	19
High Heat (R to W1 & W2)	+ 15%	On	Off	On
	+ 7.5%	On	Off	Off
	Normal	Off	Off	Off
	- 7.5%	On	On	Off
	- 15%	On	On	On

**Switches 14 through 19 -- Heating Mode Blower Speed**

-- Switches 14 through 19 are used to select heating mode blower motor speeds. These switches are factory set at the OFF position which provides 100 % of normal speed during HIGH HEAT demand, 70% of normal speed during MIDRANGE HEAT demand and 40% of normal speed during LOW HEAT demand. Switches 14, 15 and 16 are used to adjust the LOW FIRE blower motor speed. Switches 17, 18 and 19 are used to adjust the HIGH FIRE blower motor speed. FIGURE 6 and TABLE 9 and TABLE 10 provides the heating mode blower speeds that will result from different switch settings. FIGURE 6 indicates the effect the DIP switch settings have upon the heating airflow at various furnace firing rates. Refer to blower tables at the front of this manual for corresponding cfm values.

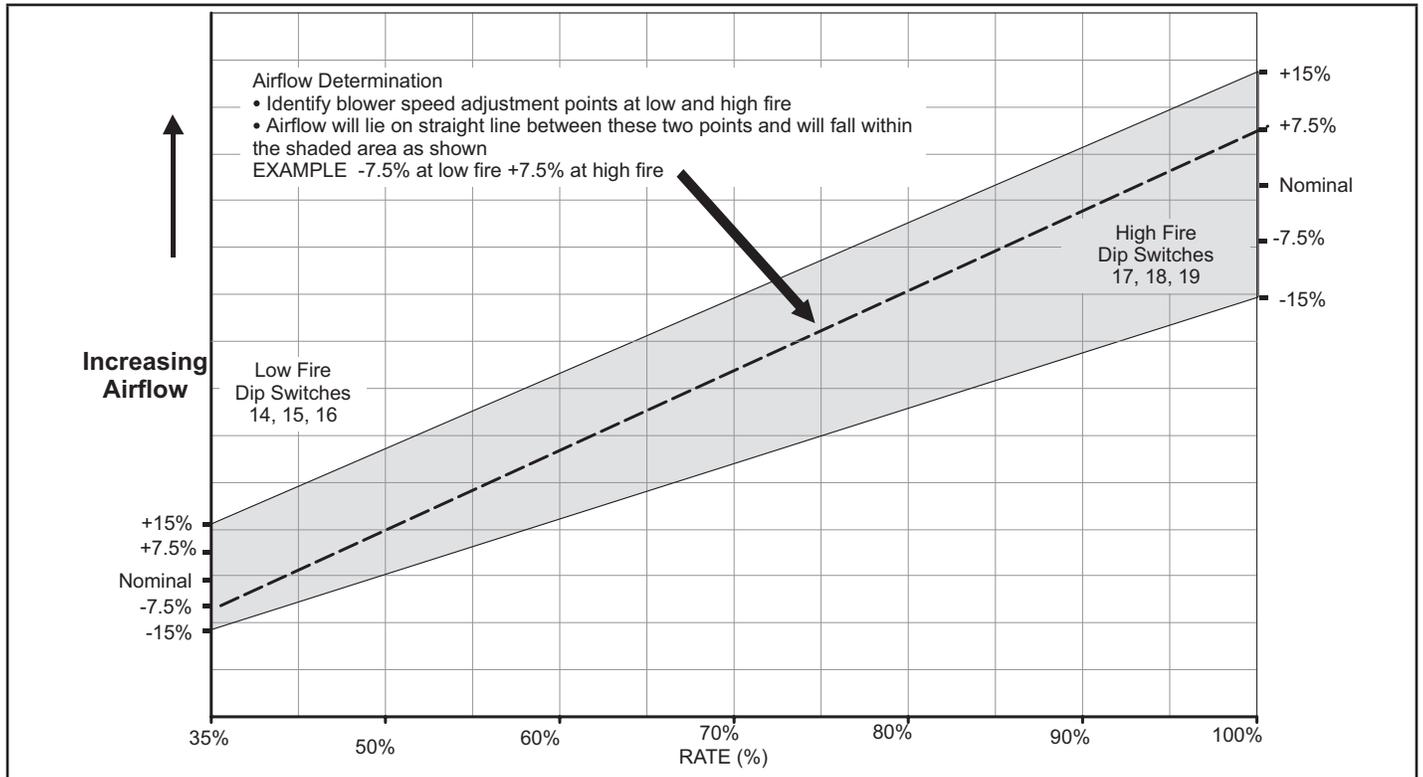

**FIGURE 6**

### On-Board Link W914 DS to R (FIGURE 4)

On-board link W914, is a clippable connection between terminals DS and R on the integrated control. W914 must be cut when the furnace is installed with either the ZSV variable zoning system or a thermostat which features humidity control. If the link is left intact the PWM signal from the ZSV control will be blocked and also lead to control damage. Refer to TABLE 15 for operation sequence in applications including SLP99UHV, a thermostat which features humidity control and a single-speed outdoor unit. TABLE 16 gives the operation sequence in applications with a twospeed outdoor unit.

### On-Board Link W951 R to O (FIGURE 4)

On-board link W951 is a clippable connection between terminals R and O on the integrated control. W951 must be cut when the furnace is installed in applications which include a heat pump unit and a thermostat which features dual fuel use. If the link is left intact, terminal "O" will remain energized eliminating the HEAT MODE in the heat pump.

### On-Board Link W915 Y1 to Y2 (FIGURE 4)

On-board link W915 is a clippable connection between terminals Y1 and Y2 on the integrated control. W915 must be cut if two-stage cooling will be used. If the link is not cut the outdoor unit will operate in second-stage cooling only.

### Diagnostic LED (FIGURE 4)

The seven-segment diagnostic LED displays operating status, target airflow, error codes and other information. TABLE 14 lists diagnostic LED codes.

### Diagnostic Push Button (FIGURE 4)

The diagnostic push button is located adjacent to the seven-segment diagnostic LED. This button is used to enable the Error Code Recall mode and the Field Test mode. Press the button and hold it to cycle through a menu of options. Every five seconds a new menu item will be displayed. When the button is released, the displayed item will be selected. Once all items in the menu have been displayed, the menu resumes from the beginning until the button is released.

### Error Code Recall Mode

Select "E" from the menu to access the most recent 10 error codes. Select "c" from the Error Code Recall menu to clear all error codes. Button must be pressed a second time while "c" is flashing to confirm command to delete codes. Press the button until a solid "≡" is displayed to exit the Error Code Recall mode.

### Field Test Mode

Use the diagnostic push button to scroll through the menu as described above. Release the button when the LED flashes "-" to select the Field Test mode.

While in the Field Test mode the technician can:

- Initiate furnace ignition and move to and hold low-fire rate by applying a R to W1 jumper.
- Initiate furnace ignition sequence and move to and hold high-fire rate by applying a jumper from R to W1 and W2.
- Initiate furnace ignition sequence and move to and hold mid-fire rate by applying a jumper to R and W2.
- Apply then remove the jumper from R to W1 and W2 to change the firing rate from low fire to mid fire and high fire.
- A vent calibration sequence can be initiated even if a thermostat signal is not present. Press and hold the push button until a solid "C" is displayed. Release the button and calibration will begin. The furnace will perform the high-fire and low-fire pressure switch calibrations and display "CAL". After calibration, the LED will return to the flashing "-" display.

During Field Test mode operation, all safety switches are still in the circuit (they are not by-passed) and indoor blower performance and timings will match DIP switch selections. Current furnace firing rate, indoor blower CFM and flame signal will be displayed. To exit the Field Test mode, press and hold the button. The menu will resume from the beginning. Also, cycle the main power to exit the Field Test mode. The integrated control will automatically exit the Field Test mode after 45 minutes of operation.

### Soft Disable

Soft disabling is when thermostat finds a device on the BUS that it does not recognize and the thermostat sends a the device a message to be in soft disabling mode until properly configured. Two horizontal bars will display.

Steps to follow if the damper control module is displaying the soft disable code.

- 1 - Confirm proper wiring between all devices (thermostat, damper control module, indoor and outdoor).
- 2 - Cycle power to the control that is displaying the soft disable code.
- 3 - Put the room thermostat through set up.
- 4 - Go to **setup / system devices / thermostat / edit** / then push **reset**.
- 5 - Go to **setup / system devices / thermostat / edit** / then push **resetAll**.

**TABLE 11****Idle Menu Options**

These options are displayed on the menu when the button is pressed during normal operation

DISPLAY	ACTION (when button released)
No change (idle)	remain in idle mode
Solid "E"	enter diagnostic mode
Solid "-"	enter field test mode

*NOTE - No change implies the display will continue to show whatever is currently being displayed for normal operation*

**TABLE 12****Idle Menu Options**

These options are displayed on the menu when the button is pressed during normal operation

DISPLAY	ACTION (when button released)
No change (blinking "-")	remain in field test mode
Solid "-"	exit field test mode
Solid "c"	start pressure switch calibration

**TABLE 13****Idle Menu Options**

These options are displayed on the menu when the button is pressed during normal operation

DISPLAY	ACTION (when button released)
No change (displaying error history)	remain in diagnostic recall mode
Solid (3 horizontal bars)	exit diagnostic recall mode
Solid "c"	clear error history

Once the button is released to clear the error history a blinking "c" will be shown on the display for up to 10 seconds. During this time the user must press and release the button one additional time to confirm the action of deleting the error history. Once the error history is deleted it cannot be recovered.

## Configuring Unit Size Codes

**Power-Up** - Number displayed represents by integrated control unit size code (furnace model and capacity). If three horizontal bars are displayed followed by continuous E203, furnace control does not recognize **unit size code**. Configure per the following:

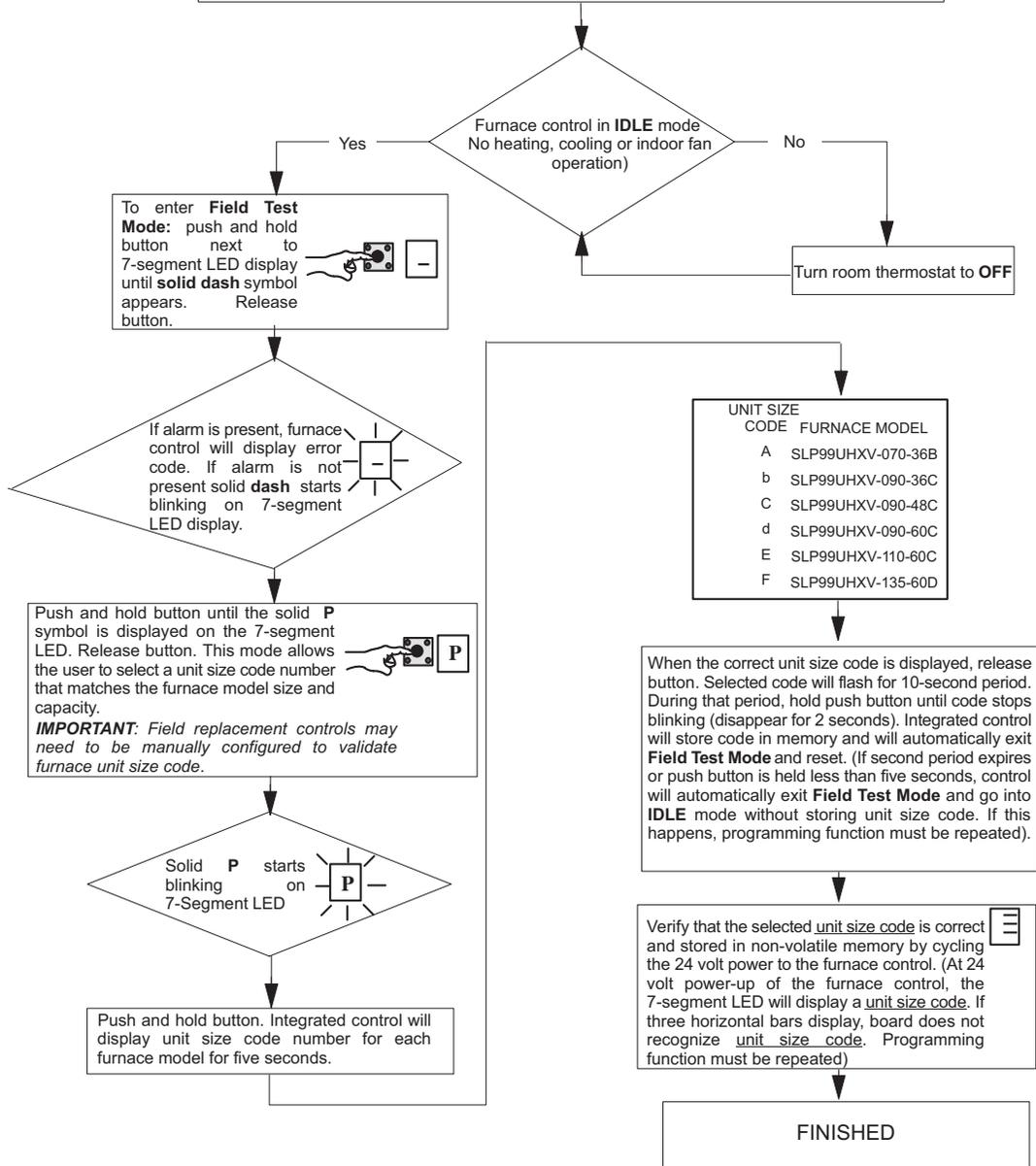

**TABLE 14**

**LED 7 Segment Status / Error Code**

Press the diagnostic push button and hold it to cycle through a menu of options. Every five seconds a new menu item will be displayed.

Release the button when the desired mode is displayed.

When a solid "P" is displayed, the furnace capacity/ size is programmed.

When the solid "E" is displayed, the control enters the Error Code Recall mode. Error Code Recall mode menu options: No change (displaying error history) remains in Error Code Recall mode; solid "b" exits Error Code Recall mode; and solid "c" clears the error history. Must press button while flashing "c" is displayed to clear error codes.

When the solid "-" is displayed, the control enters the Field Test mode. Field Test mode menu options: Solid "C" starts pressure switch calibration; blinking "-" exits Field Test mode.

Code	Diagnostic Codes/Status of Equipment	Action Required to Clear and Recover
.	Idle mode (Decimal blinks at 1 Hertz -- 0.5 second ON, 0.5 second OFF).	
A	Cubic feet per minute (cfm) setting for indoor blower (1 second ON, 0.5 second OFF) / cfm setting for current mode displayed.	
C	Cooling stage (1 second ON, 0.5 second OFF) / 1 or 2 displayed / Pause / cfm setting displayed / Pause / Repeat codes).	
d	Cooling stage (1 second ON, 0.5 second OFF) / 1 or 2 displayed / Pause / cfm setting displayed / Pause / Repeat codes).	
h	Variable Capacity Heat (1 second ON, 0.5 second OFF) / % of input rate displayed / Pause/ cfm setting / Pause/ Repeat codes.	
H	Heat Stage (1 second ON, 0.5 second OFF) / 1 or 2 displayed / Pause / cfm setting displayed / Pause / Repeat codes.	
df	Defrost mode.	
U	Discharge air temperature	
-	Soft disable - Soft disabling is when thermostat finds a device on the BUS that it does not recognize and the thermostat sends a the device a message to be in soft disabling mode until properly configured. Two horizontal bars will display.	Steps to follow if the damper control module is displaying the soft disable code. Confirm proper wiring between all devices (thermostat, damper control module, indoor and outdoor). Cycle power to the control that is displaying the soft disable code. Put the room thermostat through set up. Go to setup / system devices / thermostat / edit / then push reset. Go to setup / system devices / thermostat / edit / then push resetAll.
E105	Device communication problem - No other devices on BUS (Communication system).	Equipment is unable to communicate. Check for mis wire and loose connections and check for a high voltage source of noise close to the system. (welder etc.).
E110	Low line voltage.	Line Voltage low (Voltage lower than nameplate rating) Check voltage.
E113	High line voltage.	Line Voltage High (Voltage higher than nameplate rating) Check voltage.
E114	Line voltage frequency out-of-range.	No 60 hertz power (Check voltage and frequency).
E115	Low 24V - Control will restart if the error recovers.	24 voltage low (Range is 18 to 30 volts) Check voltage.
E120	Unresponsive device.	Usually caused by delay in outdoor unit responding to indoor unit poling recycle power, check wiring.
E124	Active communicating thermostat signal missing for more than 3 minutes.	Equipment lost communication with the thermostat. Check connections and cycle power on the thermostat.
E125	Control failed self-check, internal error, failed hardware. Will restart if error recovers. Integrated furnace control not communicating. Covers hardware errors (flame sense circuit faults, pin shorts, etc.).	Hardware problem on the control board. Cycle power on control. Replace if problem prevents service and is persistent.
E126	Failed internal control communication between microcontrollers.	Hardware problem on the control board. Cycle power on control. Replace if problem prevents service and is persistent.
E180	Outdoor air sensor failure - NO error if disconnected. Only shown if shorted or out-of-range.	

## Integrated Control Diagnostic Codes (Continued)

Code	Diagnostic Codes/Status of Equipment	Action Required to Clear and Recover
E200	Hard lockout - Rollout circuit open or previously open.	Correct unit cause of rollout trip or replace flame rollout switch and test furnace operation.
E201	Indoor blower communication failure - Unable to communicate with blower motor.	Indoor blower communication failure including power outage.
E202	Indoor blower motor mis-match - Indoor motor horsepower does not match unit capacity.	Incorrect furnace size code selected. Check unit size codes on configuration guide or in installation instructions.
E203	Appliance capacity / size is NOT programmed. Invalid unit codes refer to configuration flow chart in installation instructions.	No furnace size code selected. Check unit size codes on configuration guide or in installation instructions.
E204	Gas valve mis-wired.	Check operation of gas valve.
E205	Gas valve control relay contact shorted.	Check operation of gas valve.
E207	Hot surface ignitor sensed open - Refer to troubleshooting in installation instruction.	Measure resistance of Hot Surface Ignitor, replace if open or not within specification.
E223	Low pressure switch failed open - Refer to troubleshooting in installation instruction.	Check inches of water column pressure during operation of low pressure switch on heat call, measure inches of water column of operating pressure, inspect vent and combustion air inducer for correct operation and restriction.
E224	Low pressure switch failed closed - Refer to troubleshooting in installation instruction.	Check low pressure switch for closed contacts, measure inches of water column of operating pressure, inspect vent and combustion air inducer for correct operation and restriction.
E225	High pressure switch failed open - Refer to troubleshooting in installation instruction.	Check inches of water column pressure of high pressure switch on heat call, measure inches of water column of operating pressure, inspect vent and combustion air inducer for correct operation and restriction.
E226	High pressure switch failed closed - Refer to troubleshooting in installation instruction.	Check high pressure switch for closed contacts, measure inches of water column of operating pressure, inspect vent and combustion air inducer for correct operation and restriction.
E227	Low pressure switch open during trial for ignition or run mode. Refer to troubleshooting in installation instruction.	Check inches of water column pressure during operation of low pressure switch on heat call, measure inches of water column of operating pressure, inspect vent and combustion air inducer for correct operation and restriction.
E228	Unable to perform successful pressure switch calibration.	Retry after 300 seconds. Error counter cleared when exiting lockout, unable to perform pressure switch calibration. Check vent system and pressure switch wiring connections.
E240	Low flame current - Run mode - Refer to troubleshooting in installation instruction.	Check micro amperes of flame sensor, clean or replace sensor. Measure voltage of neutral to ground for good unit ground.
E241	Flame sensed out of sequence - Flame still present.	Shut off gas, check for gas valve leak.
E250	Limit switch circuit open - Refer to troubleshooting in installation instruction.	Check why limit is tripping, overfired, low air flow.
E252	Discharge air temperature too high (gas heat only).	Check temperature rise, air flow and input rate.
E270	Soft lockout - Exceeded maximum number of retries. No flame current sensed.	Check for gas flow, ignitor lighting burner, flame sensor current.
E271	Soft lockout - Exceeded maximum number of retries. Last retry failed due to the pressure switch opening.	See E 223.
E272	Soft lockout - Exceeded maximum number of recycles. Last recycle due to the pressure switch opening.	See E 223 and E 225.
E273	Soft lockout - Exceeded maximum number of recycles. Last recycle due to flame failure.	See E 240.

## Integrated Control Diagnostic Codes (Continued)

Code	Diagnostic Codes/Status of Equipment	Action Required to Clear and Recover
E274	Soft lockout - Exceeded maximum number of recycles. Last recycle failed due to the limit circuit opening or limit remained open longer than 3 minutes.	See E 250.
E275	Soft lockout - Flame sensed out of sequence from code 241 fault. Flame signal is gone.	See E 241.
E276	Soft lockout - Exceeded maximum number of calibration retries.	See E 228.
E290	Ignitor circuit fault - Failed ignitor or triggering circuitry.	See E 207.
E291	Restricted air flow - Cubic feet per minute is lower than what is needed for minimum firing rate.	Check for dirty filter, unit air flow restriction, blower performance.
E292	Indoor blower motor unable to start - Seized bearings, stuck wheel, etc.	Indoor blower motor unable to start (seized bearing, stuck wheel, etc), replace motor or wheel if assembly does not operate or meet performance.
E294	Combustion air inducer motor amp draw is too high.	Check combustion blower bearings, wiring , amperes, replace if it does not operate or meet performance.
E295	Indoor blower motor temperature is too high.	Indoor blower motor over temperature (motor tripped on internal protector), Check motor bearings, amperes. Replace if necessary.
E310	Discharge error sensor failure - No error if disconnected. Only shown if shorted or out-of-range.	Discharge air temperature(DATS) out of range, code is activated during "Field test mode".
E311	Heat rate reduced to match indoor blower air flow. Replace filter or repair duct restriction.	Furnace blower in cutback mode due to restricted airflow. Check filter and ductwork. To clear replace filter if needed or repair/ add ductwork.
E312	Restricted air flow in cooling or continuous fan mode is lower than cfm setting.	Restricted airflow - Indoor blower is running at a reduced cubic feet per minute (Cutback Mode) - The variable speed motor has pre-set speed and torque limiters to protect the motor from damage caused by operating out of its designed parameters (0 to 0.8 inches water column total external static pressure). Check filter and ductwork. To clear replace filter if needed or repair/ add ductwork.
E313	Indoor or outdoor unit capacity mismatch.	Incorrect Indoor /outdoor capacity code selected. Check for proper configuration in installation instructions. Alarm is just a warning. The system operation is not impacted at all and alarm would clear when Commissioning is exited.
E331	Global network connection - Communication link problem.	For Future Use.
E347	No 24 Volt output on Y1 to C with non-communicating outdoor unit.	Y1 relay / Stage 1 failed (Pilot relay contacts did not close or the relay coil did not energize).
E348	No 24 Volt output on Y2 to C with non-communicating outdoor unit.	Y2 relay / Stage 2 failed (Pilot relay contacts did not close or the relay coil did not energize).
E349	No 24 Volts between R & O with non-communicating outdoor unit (Dual fuel module required for heat pump application).	Only applicable in non-communicating mode. The O to R link on the furnace has been cut and could possibly cause a brown out. Might also result in low voltage to which would generate alert code as well. Configuration link R to O needs to be restored. Will need to restore link by hard-wiring the R to O terminals on the terminal strip.
E401	LSOM - Compressor ran more than 18 hours in air conditioning mode.	Compressor protector is open. Check for high head pressure, check compressor supply voltage. Outdoor unit power disconnect is open , compressor circuit breaker or fuse(s) is open, broken wire or connector is not making contact. Low or high pressure switch open if present in the system. Compressor contactor has failed to close.



**Integrated Control Diagnostic Codes (Continued)**

Code	Diagnostic Codes/Status of Equipment	Action Required to Clear and Recover
E402	LSOM - Outdoor unit system pressure trip.	Compressor ran over 18 hours in air conditioning mode.
E403	LSOM - Compressor short-cycling (Running less than 4 minutes).	Outdoor unit pressure trip. Check dirty coil, fan motor, refrigerant charge.
E404	LSOM - Compressor rotor locked.	Compressor short cycling (Running less than 4 minutes).
E405	LSOM - Compressor open circuit.	Check capacitor, wiring, hard start kit , replace Compressor.
E406	LSOM - Compressor open start circuit.	Check compressor for hot (cool down) , check pressures, fan motor etc. Replace compressor if unable to get circuit to close and compressor to operate.
E407	LSOM - Compressor open run circuit.	
E408	LSOM - Compressor contactor is welded.	
E409	LSOM - Compressor contactor is welded.	Replace contactor.

**TABLE 15**  
**OPERATING SEQUENCE**  
 SLP99UHV and Single-Stage Outdoor Unit

OPERATING SEQUENCE		SYSTEM DEMAND					SYSTEM RESPONSE		
System Condition	Step	Demand			Relative Humidity		Compressor	Blower CFM (COOL)	Comments
		1st stage	O	G	Status	D*			
<i>NO CALL FOR DEHUMIDIFICATION</i>									
Normal Operation	1	On	On	On	Acceptable	24 VAC	High	100%	Compressor and indoor blower follow thermostat demand
<i>BASIC MODE (only active on a Y1 thermostat demand)</i>									
Normal Operation	1	On	On	On	Acceptable	24 VAC	High	100%	Thermostat energizes Y1 and de-energizes D on a call for de-humidification
Dehumidification Call	2	On	On	On	Demand	0 VAC	High	70%	
<i>PRECISION MODE (operates independent of a Y1 thermostat demand)</i>									
Normal Operation	1	On	On	On	Acceptable	24 VAC	High	100%	Dehumidification mode begins when humidity is greater than set point
Dehumidification call	2	On	On	On	Demand	0 VAC	High	70%	
Dehumidification call ONLY	1	On	On	On	Demand	0 VAC	High	70%	Thermostat will keep outdoor unit energized after cooling temperature set-point has been reached in order to maintain room humidity setpoint.
On-board links at indoor unit with a single-stage outdoor unit: With Condensing unit - Cut W914 (R to DS) on SureLight® control; With Heat Pump - Cut W914 (R to DS) & W951(R to O) on SureLight® control. *CS7500 thermostat only									

**TABLE 16**  
**OPERATING SEQUENCE**  
 SLP99UHV and Single-Stage Outdoor Unit

OPERATING SEQUENCE		SYSTEM DEMAND						SYSTEM RESPONSE		
System Condition	Step	Demand				Relative Humidity		Compressor	Blower CFM (COOL)	Comments
		1st stage	2nd stage	O	G	Status	D*			
<b>NO CALL FOR DEHUMIDIFICATION</b>										
Normal Operation - Y1	1	On		On	On	Acceptable	24 VAC	Low	70%	Compressor and indoor blower follow thermostat demand
Normal Operation - Y2	2	On	On	On	On	Acceptable	24 VAC	High	100%	
<b>ROOM THERMOSTAT CALLS FOR FIRST STAGE COOLING</b>										
<i>BASIC MODE (only active on a Y1 thermostat demand)</i>										
Normal Operation	1	On		On	On	Acceptable	24 VAC	Low	70%	Thermostat energizes 2nd stage and de-energizes D on a call for dehumidification
Dehumidification Call	2	On	On	On	On	Demand	0 VAC	High	70%	
<i>PRECISION MODE (operates independent of a Y1 thermostat demand)</i>										
Normal Operation	1	On		On	On	Acceptable	24 VAC	Low	70%	Dehumidification mode begins when humidity is greater than set point
Dehumidification call	2	On	On	On	On	Demand	0 VAC	High	70%	
Dehumidification call ONLY	1	On	On	On	On	Demand	0 VAC	High	70%	Thermostat will keep outdoor unit energized after cooling temperature setpoint has been reached in order to maintain room humidity setpoint.*
<b>ROOM THERMOSTAT CALLS FOR FIRST AND SECOND STAGE COOLING</b>										
<i>BASIC MODE (only active on a Y1 thermostat demand)</i>										
Normal Operation	1	On	On	On	On	Acceptable	24 VAC	High	100%	Thermostat energizes 2nd stage and de-energizes D on a call for dehumidification
Dehumidification Call	2	On	On	On	On	Demand	0 VAC	High	70%	
<i>PRECISION MODE (operates independent of a Y1 thermostat demand)</i>										
Normal Operation	1	On		On	On	Acceptable	24 VAC	Low	70%	Dehumidification mode begins when humidity is greater than set point
Dehumidification call	2	On	On	On	On	Demand	0 VAC	High	70%	
Dehumidification call ONLY	1	On	On	On	On	Demand	0 VAC	High	70%	Thermostat will keep outdoor unit energized after cooling temperature setpoint has been reached in order to maintain room humidity setpoint.
<p>On-board links at indoor unit with a two-stage outdoor unit:            Cut factory link from Y1 to Y2 or cut W915 (Y1 to Y2) on SureLight® integrated control.            With Condensing unit - Cut W914 (R to DS) on SureLight® integrated control;            With Heat Pump - Cut W914 (R to DS) &amp; W951 (R to O) on SureLight® integrated control.            *CS7500 thermostat only</p>										

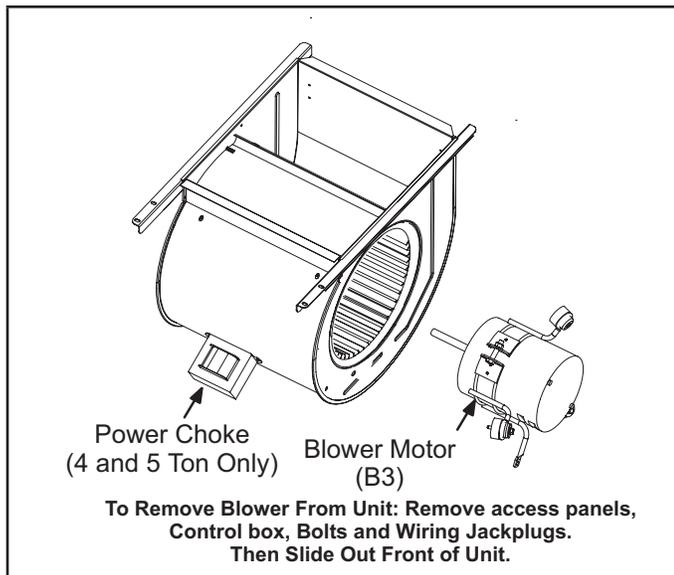

**FIGURE 7**

**1. Blower Motor (B3)**

**⚠ WARNING**

During blower operation, the ECM motor emits energy that may interfere with pacemaker operation. Interference is reduced by both the sheet metal cabinet and distance.

The SLP99UHV line uses three different motor sizes; 1/2 hp, 3/4 hp and 1hp. The motor communicates with the integrated control via a 2-way serial connection. The motor receives all necessary functional parameters from the integrated control and does not rely on a factory program like traditional variable speed motors. SLP99UHV units use a three-phase, electronically controlled D.C. brushless motor (controller converts single phase a.c. to three phase D.C.), with a permanent magnet-type rotor (FIGURE 8). Because this motor has a permanent magnet rotor it does not need brushes like conventional D.C. motors.

Internal components are shown in FIGURE 8. The stator windings are split into three poles which are electrically connected to the controller. This arrangement allows motor windings to turn on and off in sequence by the controller.

**⚠ IMPORANT**

During blower operation, the ECM motor emits energy that may interfere with pacemaker operation. Interference is reduced by both the sheet metal cabinet and distance.

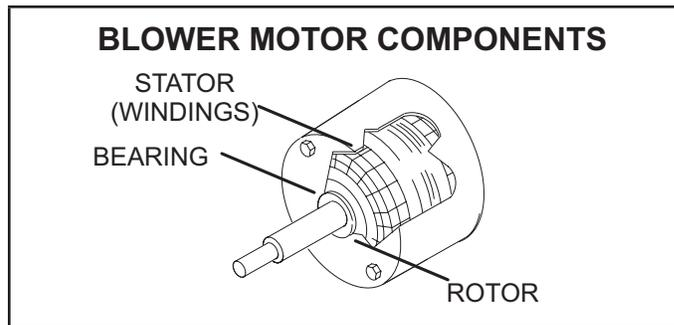

**FIGURE 8**

A solid-state controller is permanently attached to the motor. The controller is primarily an A.C. to D.C. converter. Converted D.C. power is used to drive the motor. The controller contains a microprocessor which monitors varying conditions inside the motor (such as motor workload).

The controller uses sensing devices to sense what position the rotor is in at any given time. By sensing the position of the rotor and then switching the motor windings on and off in sequence, the rotor shaft turns the blower.

All SLP99UHV blower motors use single phase power. An external run capacitor is not used. The motor uses permanently lubricated ball-type bearings.

**Internal Operation**

The motor is controlled via serial communication between the integrated control on the furnace and the controller attached to the motor shell. The messages sent back and forth between the two controls serve to communicate rotational direction, demand, motor size, current draw, torque, and rpm, among other variables.

Motor rpm is continually adjusted internally to maintain constant static pressure against the blower wheel. The controller monitors the static work load on the motor and motor amp-draw to determine the amount of rpm adjustment. Blower rpm may be adjusted any amount in order to maintain a constant cfm as shown in Blower Ratings Tables. The cfm remains relatively stable over a broad range of static pressure. Since the blower constantly adjusts rpm to maintain a specified cfm, motor rpm is not rated. Hence, the terms “cool speed”, “heat speed ” or “speed tap” in this manual, on the unit wiring diagram and on blower B3, refer to blower cfm regardless of motor rpm.

**Initial Power Up**

When line voltage is applied to B3, there will be a large inrush of power lasting less than 1/4 second. This inrush charges a bank of DC filter capacitors inside the controller. If the disconnect switch is bounced when the disconnect is closed, the disconnect contacts may become welded. Try not to bounce the disconnect switch when applying power to the unit.

### Motor Start-Up

When B3 begins start-up, the motor gently vibrates back and forth for a moment. This is normal. During this time the electronic controller is determining the exact position of the rotor. Once the motor begins turning, the controller slowly eases the motor up to speed (this is called “soft-start”). The motor may take as long as 10-15 seconds to reach full speed. If the motor does not reach 200 rpm within 13 seconds, the motor shuts down. Then the motor will immediately attempt a restart. The shutdown feature provides protection in case of a frozen bearing or blocked blower wheel. The motor may attempt to start eight times. If the motor does not start after the eighth try, the controller locks out. Reset controller by momentarily turning off power to unit.

The DC filter capacitors inside the controller are connected electrically to the motor supply wires. The capacitors take approximately 5 minutes to discharge when the disconnect is opened. For this reason it is necessary to wait at least 5 minutes after turning off power to the unit before attempting to service motor.

⚠ DANGER

Disconnect power from unit and wait at least five minutes to allow capacitors to discharge before attempting to service motor. Failure to wait may cause personal injury or death.

### Power Choke (L13)

A choke coil is used on 4 and 5 ton units equipped with 1 hp motors. The choke is located on the blower housing and is used to suppress transient current spikes.

### Troubleshooting Motor Operation

To verify motor operation see steps below.

- 1 - Remove J48 (5 pin power plug) from P48 on the motor.
- 2 - With the power on at the furnace and door switch depressed, use a test meter to verify 120V between pins 4 and 5 on J48.
- 3 - Reconnect J48 to P48 on the motor.
- 4 - Remove J49 (4 pin low voltage connector) from P49 on the motor.
- 5 - Using test jumpers, apply 24V to pins 3 and 4 on P49 on the motor.

**Note:** Do not apply 24V to pins 2 and 4 on P49. Doing so will cause permanent damage to the motor.

6 - Motor should run at 75%.

7 - Test is complete. Remove jumpers and reconnect plugs.

Another option is to use the TECMate PRO motor tester with the 16 to 4 pin adaptor. The use of the TECMate PRO isolates the motor from the integrated control. Follow the instructions provided with the kit. If the motor runs do not replace.

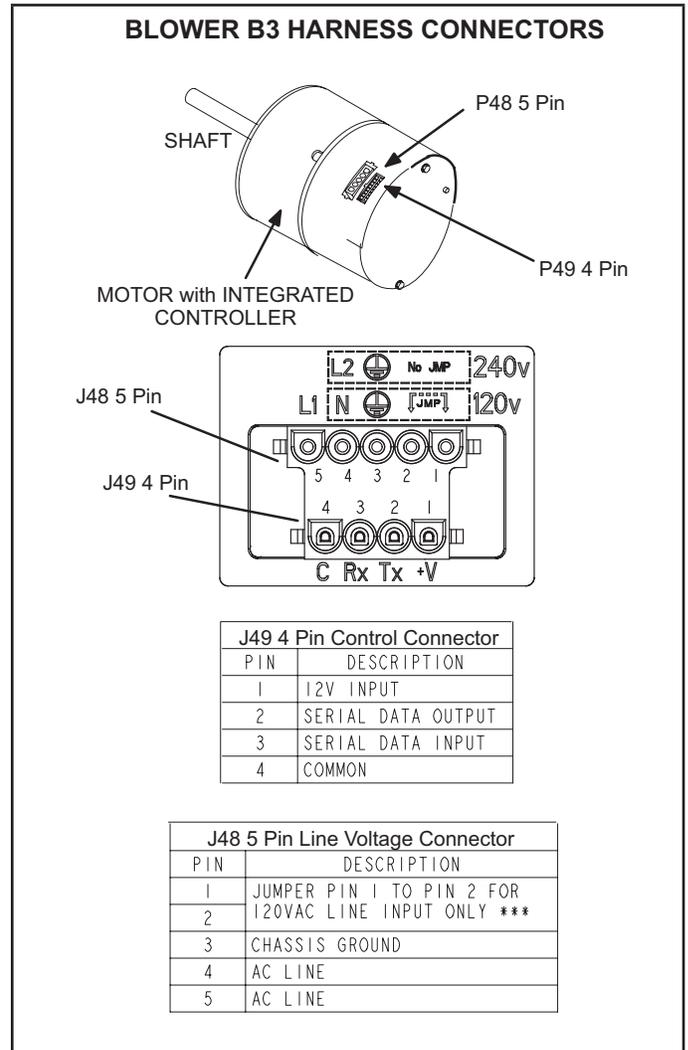

**FIGURE 9**

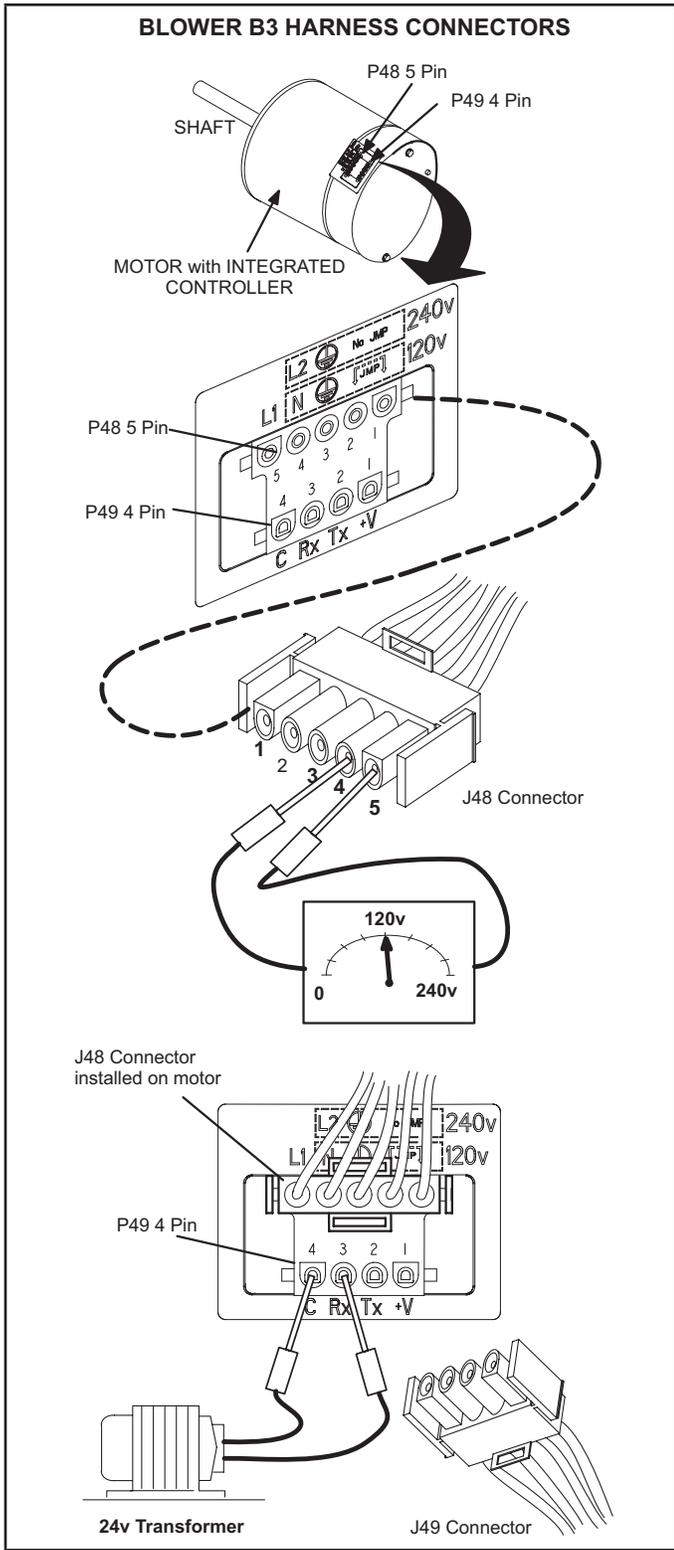

### Troubleshooting Motor Windings

Ensure that motor windings are not damaged by performing the following tests:

**NOTE** - If your ohm meter is not an auto-ranging type, set it to the highest ohm scale (100k ohms or greater) before performing tests.

**TABLE 17**

Scale	Ohm Meter Range	
	In Words	ohms
2M	two megohm - two million ohms	0 - 2,000,000
200k	two hundred kilohm - two hundred thousand ohms	0 - 200,000
20k	twenty kilohm -- twenty thousand ohms	0-20,000
2k	two kilohm -- two thousand ohms	0 - 2,000
200	two hundred ohm	0 - 200

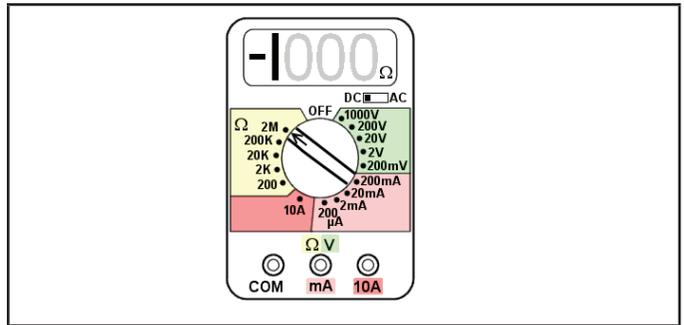
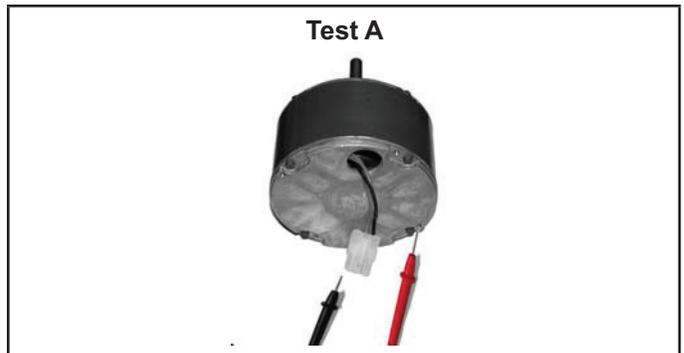

**FIGURE 11**

### TEST A

Measure the resistance between each of the three motor leads (3-pin plug) and the unpainted part of the end shield.

**If the winding resistance to ground is <100k ohms, replace the motor and control module. If the resistance to ground is >100k, the motor windings are fine. Proceed to Test B.**



**FIGURE 12**

## TEST B

Use an ohmmeter to measure the motor phase-to-phase resistance by checking these combinations of the the 3-pin motor plug. For the purpose of this test, start at either end of the connector as lead 1.

- 1 - The lead-to-lead resistance across any two leads should be less than 20 ohms.
- 2 - Each lead-to-lead resistance should be the same.

If the measured resistance is greater than 20 ohms, replace the motor and control module.

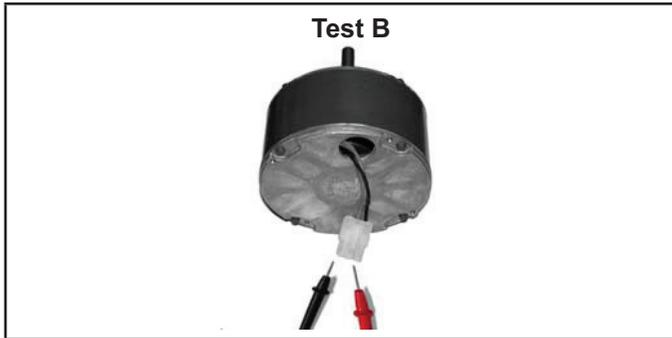

FIGURE 13

## C-Heating Components

Heating component locations are shown in FIGURE 14. Make note the cover plate for the -090XV60C model only. The cover plate is removed for LP/Propane conversion only.

### 1. Ignitor

The SureLight® ignitor is made of durable silicon nitride. Ignitor longevity is enhanced by controlling voltage to the ignitor. The integrated control provides 120 volts to the ignitor for a consistent ignition. Due to this feature of the control, voltage measured with a digital meter will be slightly lower. To measure correct voltage use a true RMS meter or ignitor can be ohmed. Ohm value should be 39 to 70.

### 2. Flame Sensor

A flame sensor (FIGURE 14) is located on the left side of the burner support. The sensor is mounted on the flame rollout plate and the tip protrudes into the flame envelope of the left-most burner. The sensor can be removed for service without removing any part of the burners. During operation, flame is sensed by current passed through the flame and sensing electrode. The SureLight control allows the gas valve to remain open as long as flame signal is sensed. To check flame sense signal use the push-button found on the integrated control and go to Field Test Mode. The menu will display the flame signal. TABLE 18 shows the flame signal for the SLP99UHV unit.

TABLE 18

Flame Signal in Microamps

Normal	Low	Drop Out
2.6 or greater	2.5 or less	1.1

**NOTE** - A much higher than normal micro amp reading (15 for example) may appear when checking flame signal.

### 3. Flame Rollout Switches

Flame rollout switch S47 is a high temperature limit located inside the burner box. Each furnace is equipped with two identical switches. The limit is a N.C. SPST manual-reset limit connected in series with the primary limit S10. When S47 senses rollout, the circuit breaks and the integrated control immediately stops ignition and closes the gas valve. If unit is running and flame rollout is detected, the gas valve will close and integrated control will be disabled. Rollout can be caused by a blocked heat exchanger, flue or lack of combustion air. The switch is factory set to trip (open) at 210°F and cannot be adjusted. The switch can be manually reset. To manually reset a tripped switch, push the reset button located on the center of the switch.

### 4. Burners

All units use inshot burners. Burners are factory set and require no adjustment. Always operate the unit with the burner box front panel in place. Each burner uses an orifice that is precisely matched to the burner input. Burners can be removed as a one piece assembly for service. If burner assembly has been removed, it is critical to align center of each burner to the center of the clamshell when re-installing. See more detail in Section VII- MAINTENANCE..

### 5. Duralock Plus Heat Exchanger (FIGURE 15)

SLP99UHV units use an aluminized steel primary and stainless steel secondary heat exchanger assembly. Heat is transferred to the air stream from all surfaces of the heat exchanger. The shape of the heat exchanger ensures maximum efficiency.

The combustion air inducer pulls fresh air through the burner box. This air is mixed with gas in the burners. The gas / air mixture is then burned at the entrance of each clamshell. Combustion gases are then pulled through the primary and secondary heat exchangers and exhausted out the exhaust vent pipe.

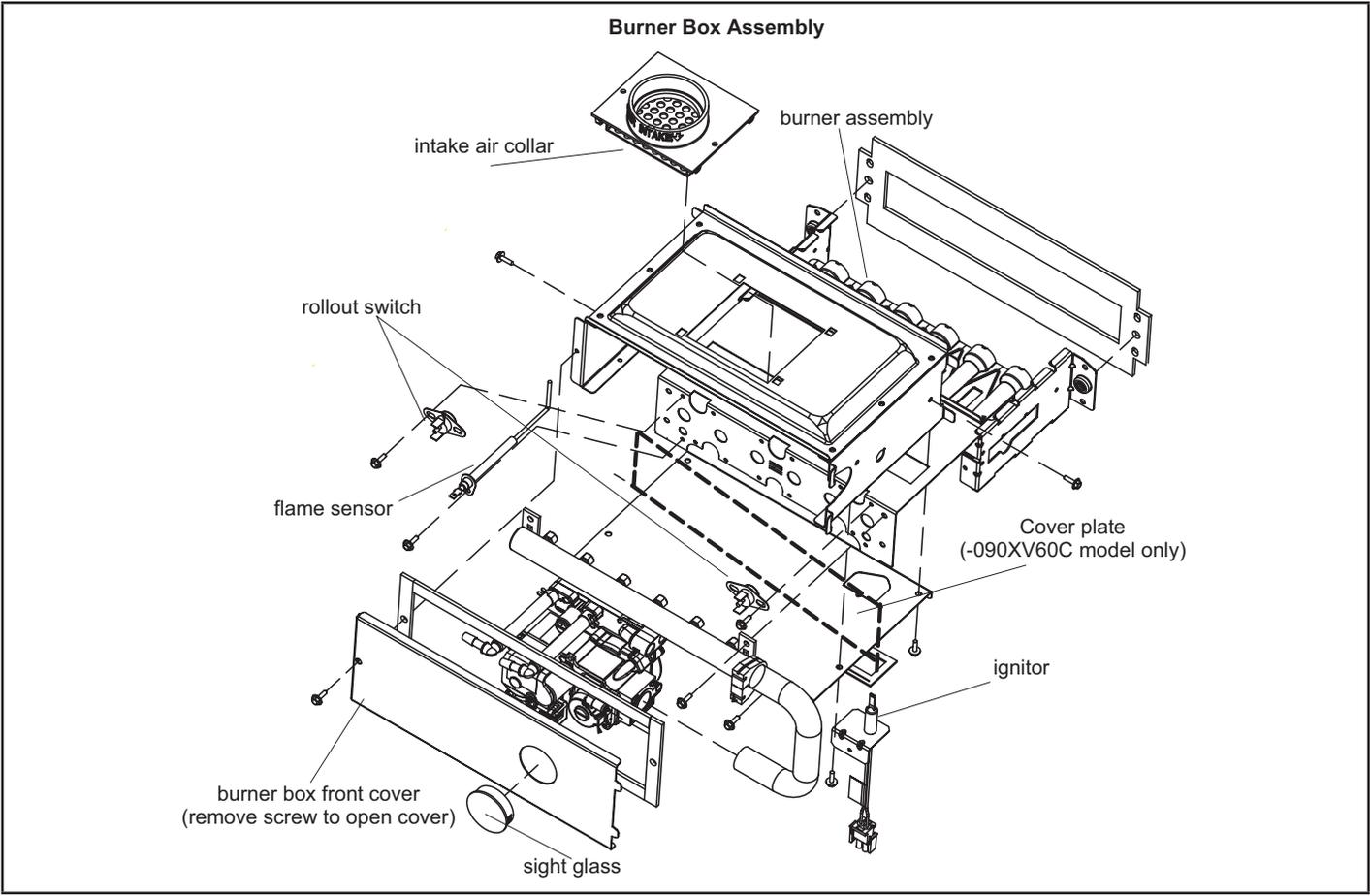

**FIGURE 14**

## 6. Primary Limit Control (S10)

FIGURE 15 shows the primary limit (S10) used on SLP99UHV units located in the heating vestibule panel. When excess heat is sensed in the heat exchanger, the limit will open. Once the limit opens, the furnace control energizes the supply air blower and de-energizes the gas valve. The limit automatically resets when unit temperature returns to normal. The switch is factory set and cannot be adjusted. In the event of restricted air flow, the integrated control will reduce firing rate and indoor blower airflow in 10% increments until a sustainable air flow is reached. If the furnace reaches 35% firing rate, and adequate air flow is not available, the furnace will shutdown and enter one hour watchguard. For limit replacement remove wires from limit terminals and rotate limit switch 90 degrees. Slowly remove from the vestibule panel.

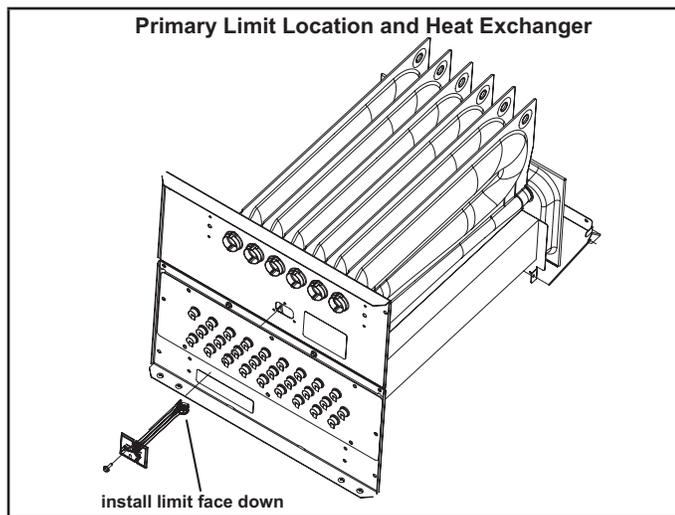

FIGURE 15

## 7. Gas Valve (GV1)

The SLP99UHV uses a variable capacity gas valve (FIGURE 16) and is applicable for two-stage or variable capacity settings. See "Thermostat selection modes" in the integrated control section (section A- subsection 4.) for more details. The valve is internally redundant to assure safety shut-off. If the gas valve must be replaced, the same type valve must be used.

A 24VAC 2-pin plug and gas control switch are located on the valve. 24V applied to the pins enables valve operation. Inlet and outlet pressure taps are located on the valve. LPG change over kits are available from Lennox. Kits include burner orifices and an LP gas valve.

## **⚠ DANGER**

**Danger of explosion.**

**There are circumstances in which odorant used with LP/propane gas can lose its scent. In case of a leak, LP/propane gas will settle close to the floor and may be difficult to smell. An LP/propane leak detector should be installed in all LP applications.**

The burner box is sealed and operates under a negative pressure. A pressure hose is connected from the burner box to the gas valve. The gas valve senses the pressure in the burner box and uses that to set the maximum manifold pressure while the pressure switch with pressure conditioning device adjusts the gas flow. This will compensate for different vent configurations which can greatly affect the rate of the unit.

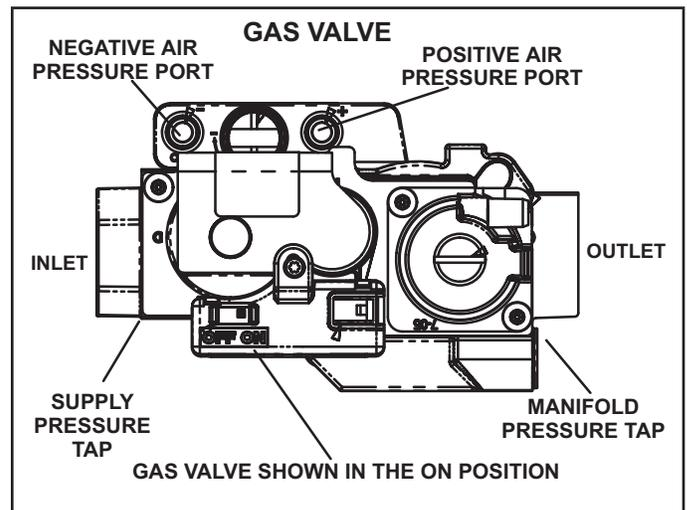

FIGURE 16



## 8. Combustion Air Inducer (B6) & Pressure Switch (S18)

All SLP99UHV units are equipped with a combustion air inducer (B6) and dual pressure switch assembly (high fire and low fire). The pressure switch (FIGURE 17) serves four functions. First it establishes calibration points for the vent calibration routine. The combustion air inducer's speed at a given firing rate is a function of the vent system resistance. The calibration routine establishes the inducer speed required to make low and high fire switches for a given vent pipe installation and interpolates the speeds required to achieve all intermediate rates between these two points. The setting for low fire switch on the assembly is such that it does not normally enter into the vent calibration routine.

Second, the switch proves combustion air inducer operation by sensing a vacuum energizing the control circuit and allowing ignition. The low fire pressure switch provides this function.

Third, the switch interrupts the combustion process in the event vent outlet or combustion air intake blockage. Finally, the switch interrupts the combustion process if the condensate drainage system becomes blocked to the point the condensate level builds up in the cold end header box/secondary coil or vent system.

If the switch assembly is to be replaced, replace the entire assembly. Individual switch components cannot be replaced.

### Combustion Air Inducer Specifications

- Three phase AC induction motor
- Sealed ball bearings
- VFD controlled by the furnace control board
- Operates at 60 to 180Hz
- Voltage range 33 - 110 VAC
- Amp draw 0.75 - 1.0
- Windings resistance 16.74 / 14.26
- Speed range 1000 - 5400 RPM

### Combustion Air Inducer Troubleshooting

- Is the CAI mounted correctly?
- Any air or condensate leaks?
- Does the motor and wheel turn freely?
- Any missing or broken mounting screws?
- Perform a visual inspection
- Clean as needed
- Measure the resistance between each of the windings. All readings should read 16.74 / 14.26 and be approximately 10% of each other.
- Check each winding to ground to confirm there is no continuity / not grounded

## **⚠ WARNING**

**The pressure switch is a safety shut-down control in the furnace and must not be jumpered for any reason other than troubleshooting.**

### Pressure Switch Troubleshooting

To troubleshoot the pressure switch, add a temporary jumper. The unit will not fire with the switch jumpered. Therefore, the pressure switch must be bypassed after the combustion air inducer is activated. This will determine if the pressure switch and furnace are operating properly. However, this may not indicate if the sealed combustion system is operating properly.

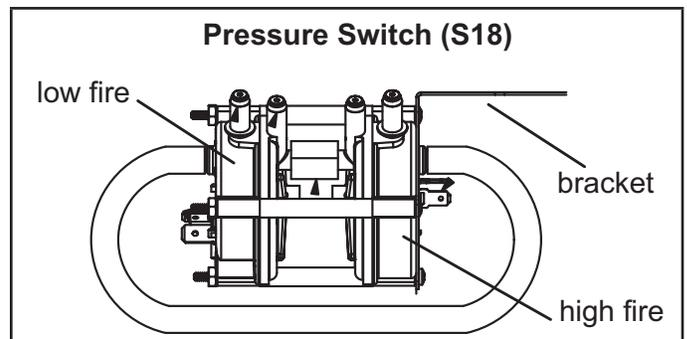

FIGURE 17

## Vent Calibration

The vent calibration sequence establishes furnace operating parameters in a specific installation. The integrated control runs the calibration and may be repeated as necessary to maintain proper furnace operation. Prior to calibration, all duct work (and returns) vent pipe and condensate trap (primed) must be connected.

If calibration is successful the data is stored in memory and will be used to determine furnace operation and maintain parameters during heat call. If calibration is not successful, the integrated control will proceed to a 5 minute delay and signal the appropriate code. After the 5 minute delay the calibration will be repeated 4 more times with a 5 minute delay in between. If still unsuccessful after the 4 trials (total 5) the integrated control will go into a 1 hour soft lockout.

Calibration may be initiated by:

- Initial call for heat
- Cycling main power off / on and then call for heat
- Venting conditions change (affecting high and low pressure switch operation)
- Ramp down low fire switch check failed (calibration will follow next call for heat)
- The service technician (by pressing the push button found on the integrated control until the control cycles through to "Field Test Mode")

The integrated control will do the following during calibration:

- 1 - Verify both low pressure switch and high pressure switch are open. If either are closed log error and end calibration.
- 2 - Start inducer at a predetermined low RPM (1600). Wait 7.5 seconds.
- 3 - Check low pressure switch, if open, increase RPM by 250, wait 5 seconds. Repeat this step until low pressure switch is closed.
- 4 - Decrease RPM by 50, wait 5 seconds and look for the low pressure switch to open. Repeat this step until it is open.
- 5 - Keep this RPM as RPM1.
- 6 - Increase RPM by 1250. Wait 5 seconds.

- 7 - Check high pressure switch, if open, increase RPM by 250, wait 5 seconds. Repeat this step until high pressure switch is closed.
- 8 - Decrease RPM by 50, check after 5 seconds. Repeat this step until switch is open.
- 9 - Keep this RPM as RPM2.
- 10 - Calibration complete.

*NOTE - If after a successful calibration and a heat call is present the integrated control will by-pass the prepurge state and go straight into ignitor warm up*

After calibration, the integrated control stores the RPM1 and RPM2 values. The low fire (35%) and high fire (100%) RPM points are calculated by adding margin values to the RPM1 and RPM2 values.

The integrated control also initiates a low fire switch check at the end of a normal heating cycle described below. If this check fails the pressure switch calibration will follow on the next call for heat.

- 1 - The inducer runs 15 seconds at the last firing rate before the heat call ended.
- 2 - Inducer runs at 35% firing rate RPM (RPM1 + low pressure switch open RPM margin value).
- 3 - If low pressure switch is open, set flag for calibration on next call for heat. Turn inducer off until next call for heat.
- 4 - If low pressure switch is closed move inducer speed to RPM1. Allow 5 seconds for stabilization.
- 5 - If low pressure switch opens turn off inducer. No further action.
- 6 - If low pressure switch is still closed, decrease inducer speed 1/2 of the low pressure switch open RPM margin. Allow 5 seconds to stabilize.
- 7 - If low pressure switch is open turn off inducer. No further action.
- 8 - If low pressure switch is still closed, set flag for calibration on next call for heat and turn off inducer.

### Measuring pressure differential (FIGURE 18)

Checks of pressure differential can aid in troubleshooting. Lennox provides a kit (10L34) if necessary. When measuring the pressure differential, readings should be taken at the pressure switch. Lack of differential usually indicates problems in the intake or exhaust piping, but may indicate problems in the heat exchanger, condensing coil, header boxes, combustion inducer or other components.

The differential pressure is the difference in pressure measured across the cold end header box orifice.

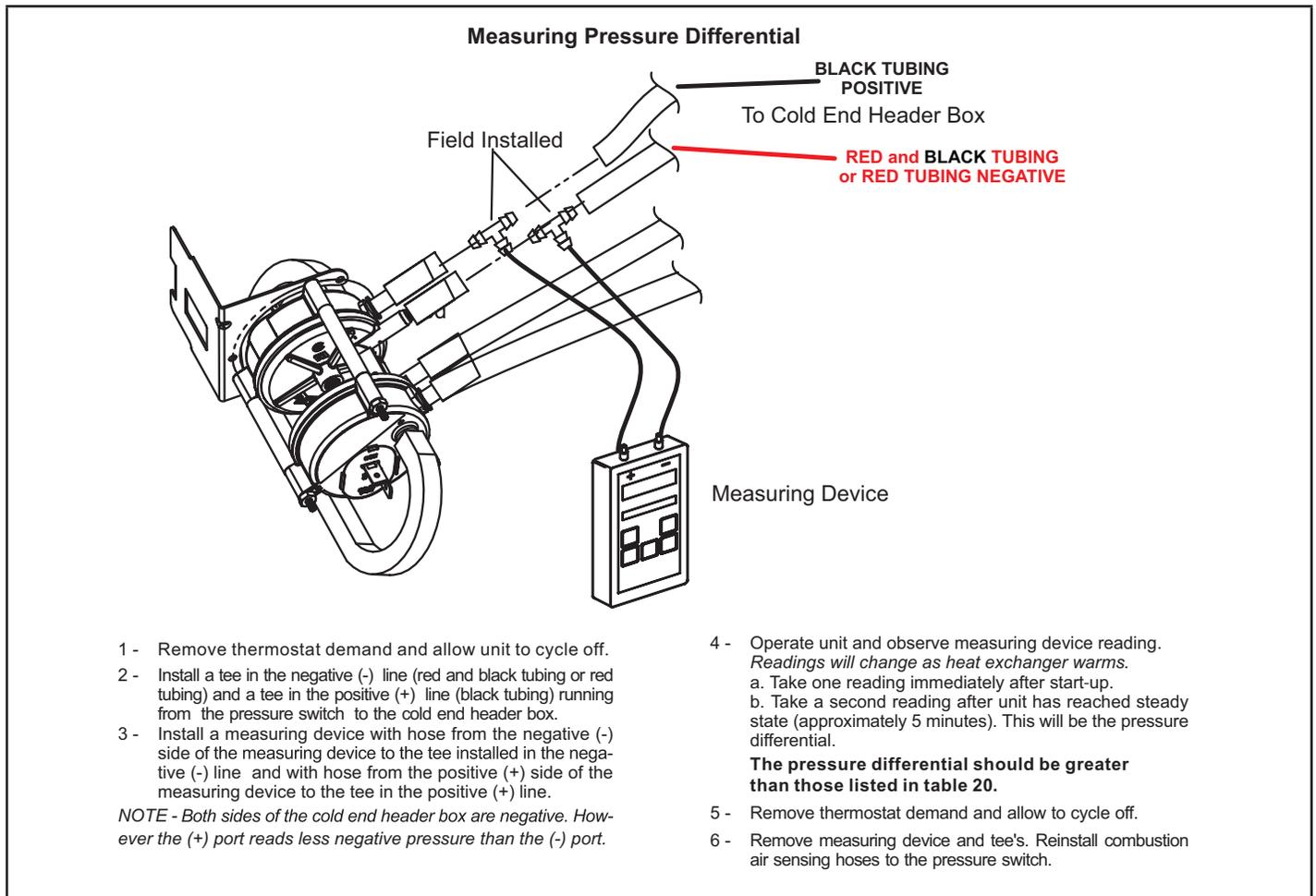

**FIGURE 18**

The CAI is installed on the cold end header box. The cold end header box is a single piece made of hard plastic. The box has an internal channel where the combustion air inducer creates negative pressure at unit start up. The channel contains an orifice used to regulate flow created by the CAI. The box has pressure taps for the CAI pressure switch hoses.

The pressure switch measures the pressure differential across the CAI orifice (difference in the channel and cold end header box). See TABLE 19 for orifice size per unit. **If replacement is necessary the gaskets used to seal the box to the vestibule panel and the CAI to the box, must also be replaced.**

**TABLE 19**

SLP99UHV Unit	C.A.I Orifice
-070	0.775
-09036C/48C	0.890
-09060C	0.840
-110	1.000
-135	1.100

**TABLE 20**

**Pressure Switch 0' to 7500'**

SLP99UHV	Set Point High Fire	Set Point Low Fire
-070	1.00 ± 0.05	0.25 ± 0.05
-09036C/48C	1.00 ± 0.05	0.25 ± 0.05
-09060C	1.00 ± 0.05	0.15 ± 0.05
-110	1.00 ± 0.05	0.25 ± 0.05
-135	1.00 ± 0.05	0.25 ± 0.05

*\*Units over 7500 ft will require a conversion kit. See table 31.*

## II-Communicating Thermostat (if applicable)

In communicating applications a communicating thermostat must be used. In these applications the thermostat overrides the DIP switch settings on the integrated control. Refer to the illustrations provided with the thermostat for installation, set-up and operation. See FIGURE 19 and FIGURE 20 for thermostat wiring in communicating applications.

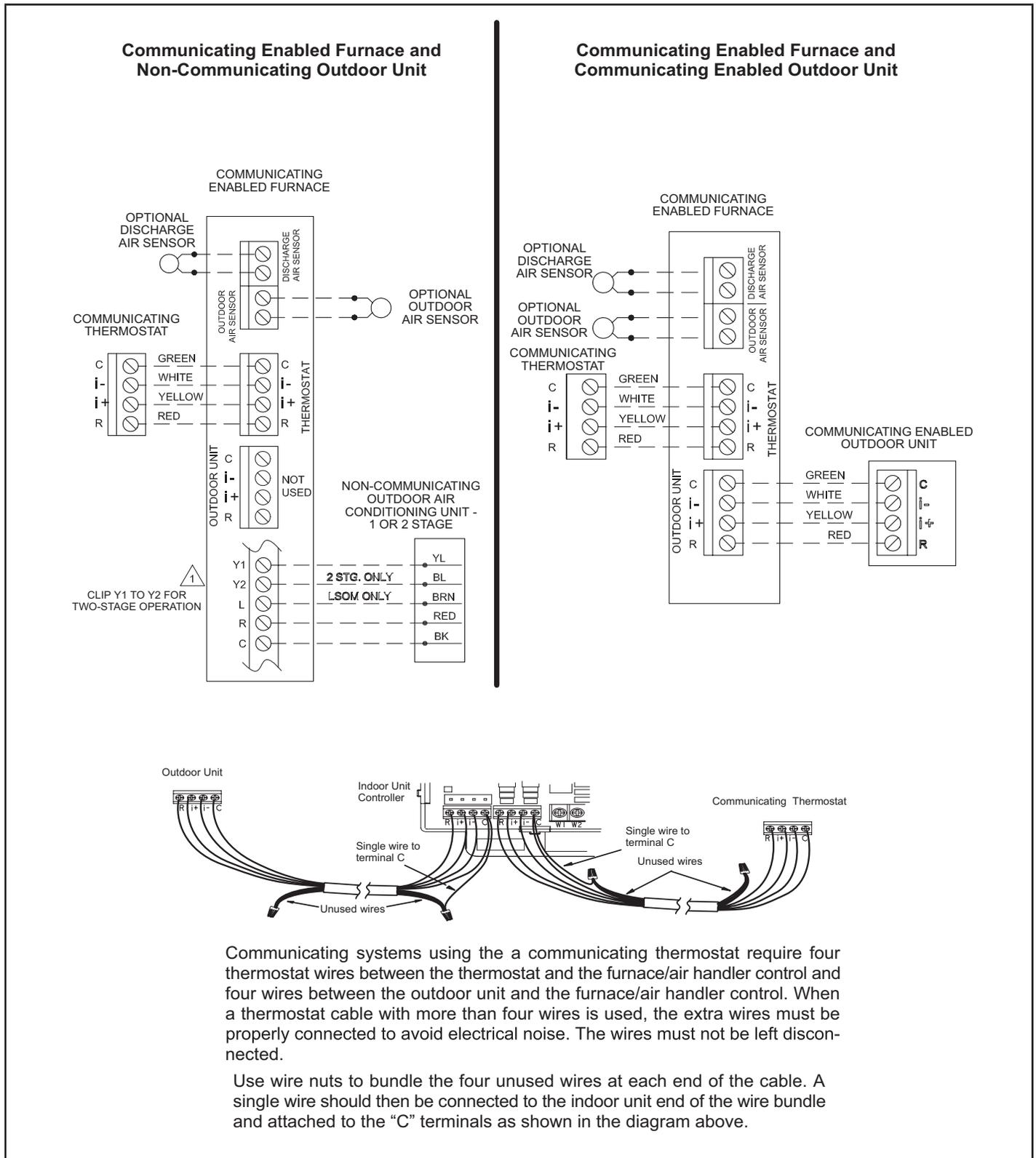

FIGURE 19

## Optional Accessories for use with any Communicating System

NOTE: THERMOSTAT SENSES HUMIDITY & CONTROLS 24V "H" OUTPUT (& 120V "H" OUTPUT) TO CYCLE HUMIDIFIER BASED ON DEMAND. NO OTHER CONTROL OR HUMIDISTAT REQUIRED.

### NOTE: 24V UV LIGHT APPLICATIONS

Furnace transformer will not have adequate va to power 24v UV light applications. An additional transformer for UV light applications is required.

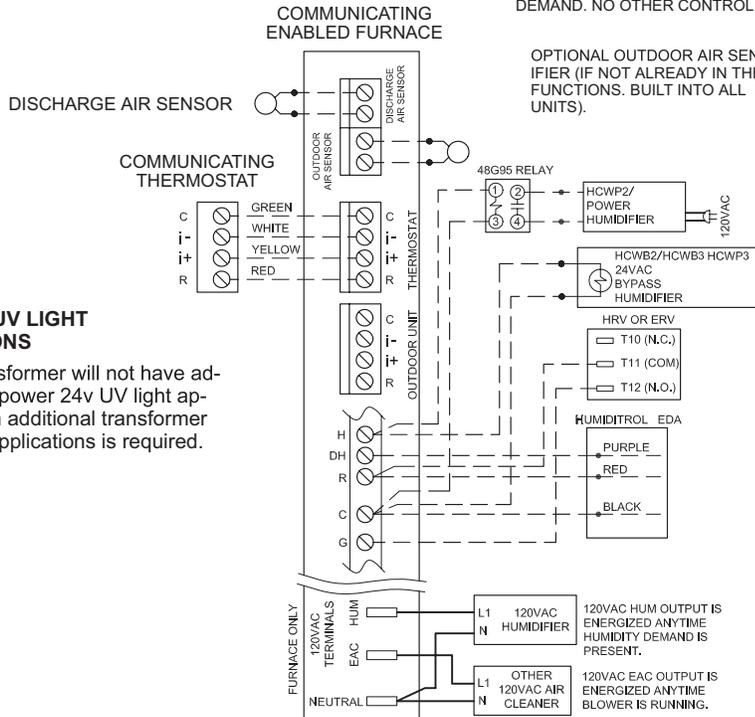

### COMMUNICATING ENABLED FURNACE

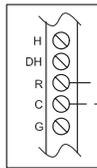

### HEPA BYPASS FILTER X2680 HEPA INTERLOCK KIT

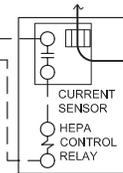

PASS INDOOR BLOWER MOTOR COMMON WIRE THROUGH CURRENT LOOP.  
SEE HEPA INTERLOCK KIT FOR INSTALLATION DETAILS

### LENNOX COMMUNICATING FURNACE EL296V, SL280V, SL280VN, SL297V, SLP99V

cutting DS to R will not cause communication interruption or error code

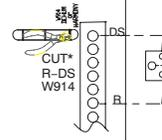

### COMMUNICATING ENABLED FURNACE

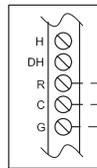

### LVCS VENTILATION CONTROL SYSTEM

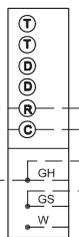

SEE LVCS VENTILATION INSTRUCTIONS FOR DAMPER & SENSOR WIRING  
26L56 CURRENT SENSING RELAY KIT  
PASS INDOOR BLOWER MOTOR COMMON WIRE THROUGH CURRENT LOOP.

### COMMUNICATING ENABLED FURNACE

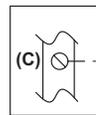

### NON-COMMUNICATING 1 OR 2 STAGE AC OR HP UNIT

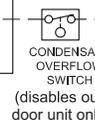

(disables outdoor unit only)

OTHER OUTDOOR CONNECTIONS REMAIN THE SAME, REFER TO SPECIFIC DIAGRAM

FIGURE 20

### III-PLACEMENT AND INSTALLATION

All pipe, fittings, primer and solvent cement must conform with American National Standard Institute and the American Society for Testing and Materials (ANSI/ASTM) standards. The solvent shall be free-flowing and contain no lumps, undissolved particles or any foreign matter that adversely affects the joint strength or chemical resistance of the cement. The cement shall show no gelation, stratification, or separation that cannot be removed by stirring. Refer to TABLE 21 for approved piping and fitting materials.

**TABLE 21  
PIPING AND FITTINGS SPECIFICATIONS**

Schedule 40 PVC (Pipe)	D1785
Schedule 40 PVC (Cellular Core Pipe)	F891
Schedule 40 PVC (Fittings)	D2466
Schedule 40 CPVC (Pipe)	F441
Schedule 40 CPVC (Fittings)	F438
SDR-21 PVC or SDR-26 PVC (Pipe)	D2241
SDR-21 CPVC or SDR-26 CPVC (Pipe)	F442
Schedule 40 ABS Cellular Core DWV (Pipe)	F628
Schedule 40 ABS (Pipe)	D1527
Schedule 40 ABS (Fittings)	D2468
ABS-DWV (Drain Waste & Vent) (Pipe & Fittings)	D2661
PVC-DWV (Drain Waste & Vent) Pipe & Fittings)	D2665
<b>PRIMER &amp; SOLVENT CEMENT</b>	<b>ASTM SPECIFICATION</b>
PVC & CPVC Primer	F656
PVC Solvent Cement	D2564
CPVC Solvent Cement	F493
ABS Solvent Cement	D2235
PVC/CPVC/ABS All Purpose Cement For Fittings & Pipe of the same material	D2564, D2235, F493
ABS to PVC or CPVC Transition Solvent Cement	D3188
<b>CANADA PIPE &amp; FITTING &amp; SOLVENT CEMENT</b>	<b>MARKING</b>
PVC & CPVC Pipe and Fittings	ULCS636
PVC & CPVC Solvent Cement	
ABS to PVC or CPVC Transition Cement	
<b>POLYPROPYLENE VENTING SYSTEM</b>	
PolyPro® by Duravent	UL1738
InnoFlue® by Centrotherm	
<b>UL 1738 CERTIFIED GAS VENTING SYSTEM</b>	
IPEX System1738 Schedule 40 PVC Pipes and Fittings	UL1738
IPEX System1738 PVC FGV Cement & Primer	

### CAUTION

Solvent cements for plastic pipe are flammable liquids and should be kept away from all sources of ignition. Do not use excessive amounts of solvent cement when making joints. Good ventilation should be maintained to reduce fire hazard and to minimize breathing of solvent vapors. Avoid contact of cement with skin and eyes.

### DANGER

#### DANGER OF EXPLOSION!

Fumes from PVC glue may ignite during system check. Allow fumes to dissipate for at least 5 minutes before placing unit into operation.

### IMPORTANT

SLP99UHV exhaust and intake connections are made of PVC. Use PVC primer and solvent cement when using PVC vent pipe. When using ABS vent pipe, use transitional solvent cement to make connections to the PVC fittings in the unit.

Use PVC primer and solvent cement or ABS solvent cement meeting ASTM specifications, refer to TABLE 21. As an alternate, use all purpose cement, to bond ABS, PVC, or CPVC pipe when using fittings and pipe made of the same materials. Use transition solvent cement when bonding ABS to either PVC or CPVC.

Low temperature solvent cement is recommended. Metal or plastic strapping may be used for vent pipe hangers. Uniformly apply a liberal coat of PVC primer for PVC

**TABLE 22  
OUTDOOR TERMINATION USAGE\***

Input Size	Vent Pipe Dia. in.	STANDARD				CONCENTRIC		
		Flush Mount Kit	Wall Kit		Field Fabricated	1-1.2 inch	2 inch	3 inch
			2 inch	3 inch		71M80 (US) 44W92 (CA)	69M29 (US) 44W92 (CA)	60L46 (US) 44W93 (CA)
		51W11 (US) 51W12 (CA)	22G44 (US) 30G28 (CA)	44J40 (US) 81J20 (CA)				
070	<sup>6</sup> 1-1/2	<sup>3</sup> YES	YES	<sup>1</sup> YES	<sup>5</sup> YES	<sup>2</sup> YES		
	2	<sup>3</sup> YES	YES	<sup>1</sup> YES	<sup>5</sup> YES	<sup>2</sup> YES		
	2-1/2	<sup>3</sup> YES	YES	<sup>1</sup> YES	<sup>5</sup> YES	<sup>2</sup> YES		
	3	<sup>3</sup> YES	YES	<sup>1</sup> YES	<sup>5</sup> YES	<sup>2</sup> YES		
090	2	<sup>3</sup> YES		YES	<sup>5</sup> YES		YES YES	
	2-1/2	<sup>3</sup> YES		YES	<sup>5</sup> YES		YES YES	
	3	<sup>3</sup> YES		YES	<sup>5</sup> YES		YES YES	
110	2	YES		YES	<sup>5</sup> YES		YES YES	
	2-1/2	YES		YES	<sup>5</sup> YES		YES YES	
	3	YES		YES	<sup>5</sup> YES		YES YES	
135	3	YES		YES	<sup>5</sup> YES		YES	

NOTE - Standard Terminations do not include any vent pipe or elbows external to the structure. Any vent pipe or elbows external to the structure must be included in total vent length calculations. See vent length tables.

\* Kits must be properly installed according to kit instructions.

1 Requires field-provided outdoor 1-1/2" exhaust accelerator.

2 Concentric kits 71M80 and 44W92 include 1-1/2 in. outdoor accelerator, when used with 070 input models. When 1-1/2 in. pipe is used it must transition to 2 in. pipe with the concentric kit.

3 Flush mount kits 51W11 and 51W12 includes 1-1/2 in. outdoor exhaust accelerator, required when used with 070 and 090 input models. When 1-1/2 in. pipe is used it must transition to 2 in. pipe with the flush mount kit.

4 Termination kits 30G28, 44W92, 4493 and 81J20 are certified to ULC S636 for use in Canada only.

5 See table 26 for vent accelerator requirements.

6 2 in. to 1-1/2 in. **field provided** reducer required.

**Canadian Applications Only - Pipe, fittings, primer and solvent cement used to vent (exhaust) this appliance must be certified to ULC S636 and supplied by a single manufacturer as part of an approved vent (exhaust) system. In addition, the first three feet of vent pipe from the furnace flue collar must be accessible for inspection. TABLE 22 lists the available exhaust termination kits.**

**Joint Cementing Procedure**

All cementing of joints should be done according to the specifications outlined in ASTM D 2855.

**NOTE - A sheet metal screw may be used to secure the intake pipe to the connector, if desired. Use a drill or self tapping screw to make a pilot hole.**

- 1 - Measure and cut vent pipe to desired length.
- 2 - Debur and chamfer end of pipe, removing any ridges or rough edges. If end is not chamfered, edge of pipe may remove cement from fitting socket and result in a leaking joint.  
**NOTE - Check the inside of vent pipe thoroughly for any obstruction that may alter furnace operation.**
- 3 - Clean and dry surfaces to be joined.
- 4 - Test fit joint and mark depth of fitting on outside of pipe.

- 5 - Uniformly apply a liberal coat of PVC primer for PVC or use a clean dry cloth for ABS to clean inside socket surface of fitting and male end of pipe to depth of fitting socket.
- 6 - Promptly apply solvent cement to end of pipe and inside socket surface of fitting. Cement should be applied lightly but uniformly to inside of socket. Take care to keep excess cement out of socket. Apply second coat to end of pipe.  
**NOTE - Time is critical at this stage. Do not allow primer to dry before applying cement.**
- 7 - Immediately after applying last coat of cement to pipe, and while both inside socket surface and end of pipe are wet with cement, forcefully insert end of pipe into socket until it bottoms out. Turn PVC pipe 1/4 turn during assembly (but not after pipe is fully inserted) to distribute cement evenly. DO NOT turn ABS or cellular core pipe.  
**NOTE - Assembly should be completed within 20 seconds after last application of cement. Hammer blows should not be used when inserting pipe.**
- 8 - After assembly, wipe excess cement from pipe at end of fitting socket. A properly made joint will show a bead around its entire perimeter. Any gaps may indicate a defective assembly due to insufficient solvent.
- 9 - Handle joints carefully until completely set.

## Venting Practices

### Piping Suspension Guidelines

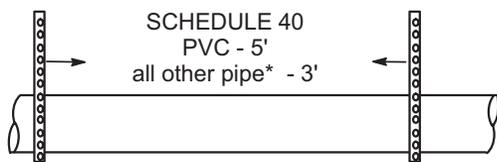

\* See Piping and Fittings Specifications table

**NOTE** - Isolate piping at the point where it exits the outside wall or roof in order to prevent transmission of vibration to the structure.

### Wall Thickness Guidelines

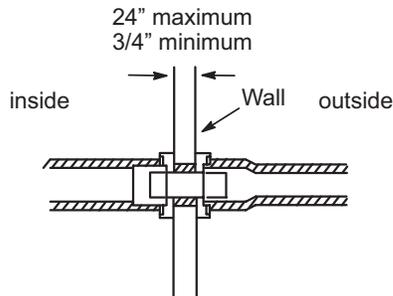

**FIGURE 21**

### REPLACING FURNACE THAT WAS PART OF A COMMON VENT SYSTEM

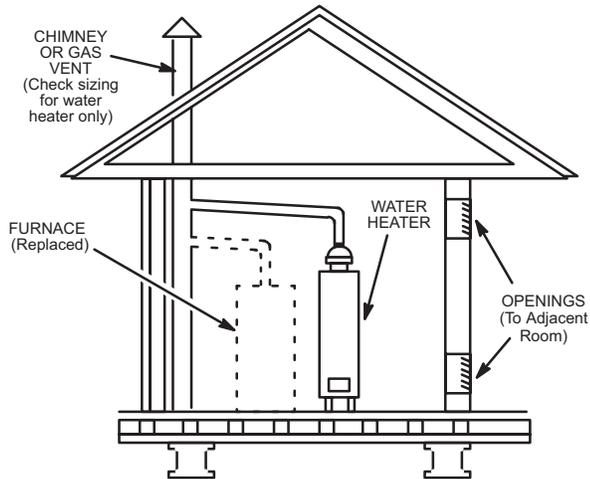

If replacing a furnace which was commonly vented with another gas appliance, the size of the existing vent pipe for that gas appliance must be checked. Without the heat of the original furnace flue products, the existing vent pipe is probably oversized for the single water heater or other appliance. The vent should be checked for proper draw with the remaining appliance.

**FIGURE 22**

- 1 - In areas where piping penetrates joists or interior walls, hole must be large enough to allow clearance on all sides of pipe through center of hole using a hanger.
- 2 - When furnace is installed in a residence where unit is shut down for an extended period of time, such as a vacation home, make provisions for draining condensate collection trap and lines.

### Exhaust Piping (FIGURE 25, FIGURE 26 and FIGURE 27)

- 3 - Route piping to outside of structure. Continue with installation following instructions given in piping termination section.

### Intake Piping (FIGURE 26 and FIGURE 27)

The SLP99UHV furnace may be installed only in direct vent applications.

The SLP99UHV is designed for combustion air intake through an inlet in the unit's top cap. Intake air piping is independent of exhaust piping.

## CAUTION

Do not discharge exhaust into an existing stack or stack that also serves another gas appliance. If vertical discharge through an existing unused stack is required, insert PVC pipe inside the stack until the end is even with the top or outlet end of the metal stack.

## CAUTION

The exhaust vent pipe operates under positive pressure and must be completely sealed to prevent leakage of combustion products into the living space.

### Vent Piping Guidelines

**NOTE** - Lennox has approved the use of DuraVent® and Centrotherm manufactured vent pipe and terminations as an option to PVC. When using the PolyPro® by DuraVent or InnoFlue® by Centrotherm venting system the vent pipe requirements stated in the unit installation instruction – minimum & maximum vent lengths, termination clearances, etc. – apply and must be followed. Follow the instructions provided with PolyPro by DuraVent and InnoFlue® by Centrotherm venting system for assembly or if requirements are more restrictive. The PolyPro by DuraVent and InnoFlue by Centrotherm venting system must also follow the uninsulated and unconditioned space criteria listed in TABLE 25.

The SLP99UHV is installed only as a Direct Vent gas central furnace.

**NOTE** - In Direct Vent installations, combustion air is taken from outdoors and flue gases are discharged outdoors. Intake and exhaust pipe sizing -- Size pipe according to TABLE 23 (minimum length permitted) and TABLE 24 (maximum length permitted). Count all elbows inside and outside the home. Regardless of the diameter of pipe used, the standard roof and wall terminations described in section Exhaust Piping Terminations should be used. Exhaust vent termination pipe is sized to optimize the velocity of the exhaust gas as it exits the termination. Refer to TABLE 26.



In some applications which permit the use of several different sizes of vent pipe, a combination vent pipe may be used. Contact Lennox' Application Department for assistance in sizing vent pipe in these applications.

Use the steps in FIGURE 24 to correctly size vent pipe diameter.

**NOTE** - It is acceptable to use any pipe size which fits within the guidelines allowed in TABLE 24.

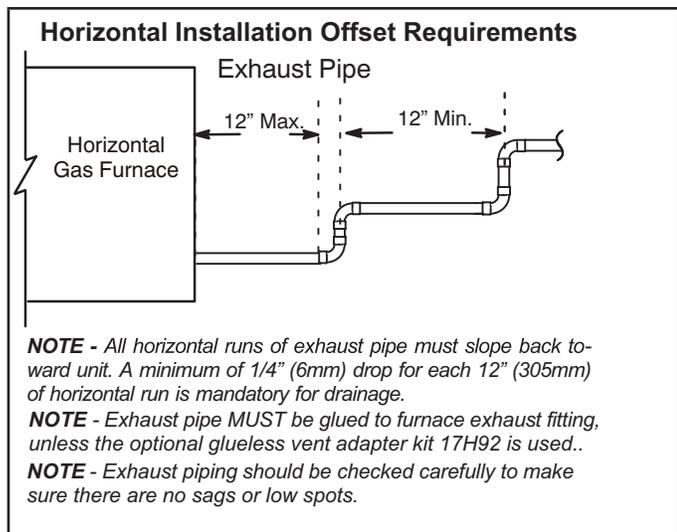

FIGURE 23

**NOTE** - The exhaust collar on all models is sized to accommodate 2" Schedule 40 vent pipe. In horizontal applications, any transition to exhaust pipe larger than 2" must be made in vertical runs of the pipe. Therefore a 2" elbow must be added before the pipe is transitioned to any size larger than 2". This elbow must be added to the elbow count used to determine acceptable vent lengths. Contact the Application Department for more information concerning sizing of vent systems which include multiple pipe sizes.

**⚠ IMPORTANT**

Do not use screens or perforated metal in exhaust or intake terminations. Doing so will cause freeze-ups and may block the terminations.

TABLE 23  
MINIMUM VENT PIPE LENGTHS

SLP99UHV MODEL	MIN.EQUIV. VENT LENGTH	EXAMPLE
070	15 ft*	5 ft. plus 2 elbows of 1-1/2", 2", 2-1/2" or 3" diameter pipe
090, 110		5 ft. plus 2 elbows of 2", 2-1/2" or 3" diameter pipe
135		5 ft. plus 2 elbows of 3" diameter pipe

\*Any approved termination may be added to the minimum equivalent length listed. Two 45 degree elbows are the equivalent to one 90 degree elbow.

**Flue Coupling**

The provided flue coupling must be attached (do not use glue) to the exhaust coupling on the furnace top panel.

Use provided bands. See steps below and FIGURE 25.

- 1 - Remove the caution sticker from flue coupling .
- 2 - Fully insert flue coupling with both bands loosely attached on the furnace exhaust coupling.
- 3 - Insert PVC exhaust pipe through flue coupling. Ensure vent pipe is fully seated into exhaust coupling. Tighten both top and bottom bands to 40 in lbs. See FIGURE 25.

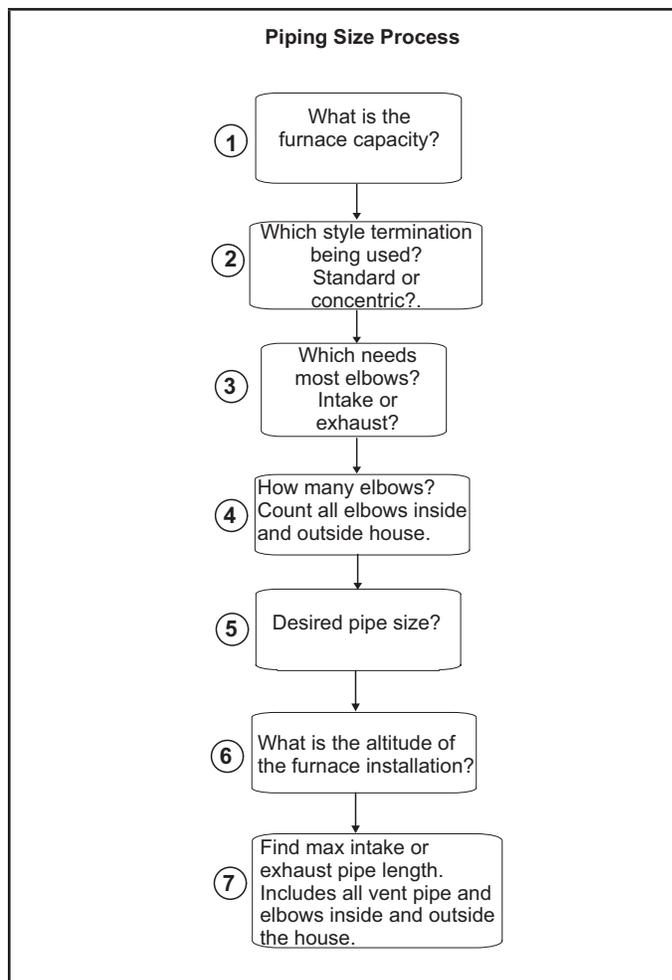

FIGURE 24

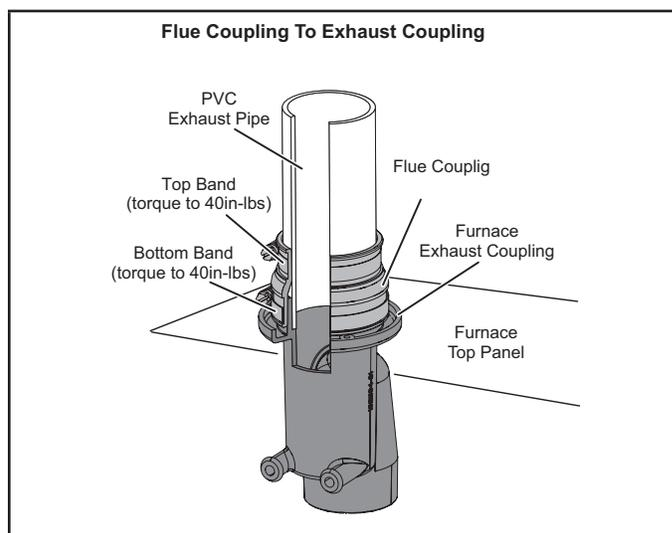

FIGURE 25

**TABLE 24**

**Maximum Allowable Intake or Exhaust Vent Length in Feet**

\*Size intake and exhaust pipe length separately. Values in table are for Intake OR Exhaust, not combined total. Both Intake and Exhaust must be same pipe size.  
 NOTE - Additional vent pipe and elbows used to terminate the vent pipe outside the structure must be included in the total vent length calculation.

<b>Standard Termination at Elevation 0 - 7500'</b>																
Number Of 90° Elbows Used	1-1/2" Pipe				2" Pipe				2-1/2" Pipe				3" Pipe			
	Model				Model				Model				Model			
	070	090	110	135	070	090	110	135	070	090	110	135	070	090	110	135
1	20	N/A	N/A	N/A	91	69	14	N/A	140	93	43	N/A	162	143	118	114
2	15				86	64	9		135	88	38		157	138	113	109
3	10				81	59	N/A		130	83	33		152	133	108	104
4	N/A				76	54			125	78	28		147	128	103	99
5					71	49	120		73	23	142		123	98	94	
6					66	44	115		68	18	137		118	93	89	
7					61	39	110		63	13	132		113	88	84	
8					56	34	105		58	N/A	127		108	83	79	
9					51	29	100		53		122		103	78	74	
10					46	24	95		48		117		98	73	69	

<b>Standard Termination at Elevation 7501' - 10,000'</b>																
Number of 90° Elbows Used	1-1/2" Pipe				2" Pipe				2-1/2" Pipe				3" Pipe			
	Model				Model				Model				Model			
	070	090	110	135	070	090	110	135	070	090	110	135	070	090	110	135
1	12	N/A	N/A	N/A	66	44	N/A	N/A	115	68	N/A	N/A	137	118	93	89
2	7				61	39			110	63			132	113	88	84
3	N/A				56	34			105	58			127	108	83	79
4					51	29			100	53			122	103	78	74
5					46	24			95	48			117	96	73	69
6					41	19			90	43			112	93	68	64
7					36	14			85	38			107	88	63	59
8					31	N/A			80	33			102	83	58	54
9					26				75	28			97	78	53	49
10					21				70	23			92	73	48	44

**TABLE 24 Continued**

**Maximum Allowable Intake or Exhaust Vent Length in Feet**

\*Size intake and exhaust pipe length separately. Values in table are for Intake OR Exhaust, not combined total. Both Intake and Exhaust must be same pipe size.  
 NOTE - Additional vent pipe and elbows used to terminate the vent pipe outside the structure must be included in the total vent length calculation

<b>Concentric Termination 0 - 7501"</b>																
Number of 90° Elbows Used	1-1/2" Pipe				2" Pipe				2-1/2" Pipe				3" Pipe			
	Model				Model				Model				Model			
	070	090	110	135	070	090	110	135	070	090	110	135	070	090	110	135
1	15	N/A	N/A	N/A	83	67	12	N/A	130	89	39	N/A	146	139	114	105
2	10				78	62	7		125	84	34		141	134	109	100
3	N/A				73	57	N/A		120	79	29		136	129	104	95
4					68	52			115	74	24		131	124	99	90
5					63	47			110	69	19		126	119	94	85
6					58	42			105	64	14		121	114	89	80
7					53	37			100	59	N/A		116	109	84	75
8					48	32			95	54			111	104	79	70
9					43	27			90	49			106	99	74	65
10					38	22			85	44			101	94	69	60
<b>Concentric Termination 7501" - 10,000"</b>																
Number of 90° Elbows Used	1-1/2" Pipe				2" pipe				2-1/2" Pipe				3" Pipe			
	Model				Model				Model				Model			
	070	090	110	135	070	090	110	135	070	090	110	135	070	090	110	135
1	10	N/A	N/A	N/A	58	42	N/A	N/A	105	64	N/A	N/A	121	114	89	80
2	N/A				53	37			100	59			116	109	84	75
3					48	32			95	54			111	104	79	70
4					43	27			90	49			106	99	74	65
5					38	22			85	44			101	94	69	60
6					33	17			80	39			96	89	64	55
7					28	12			75	34			91	84	59	50
8					23	N/A			70	29			86	79	54	45
9					18				65	24			81	74	49	40
10	13				60				19	76			69	44	35	

**TYPICAL EXHAUST AND INTAKE PIPE CONNECTIONS IN UPFLOW**

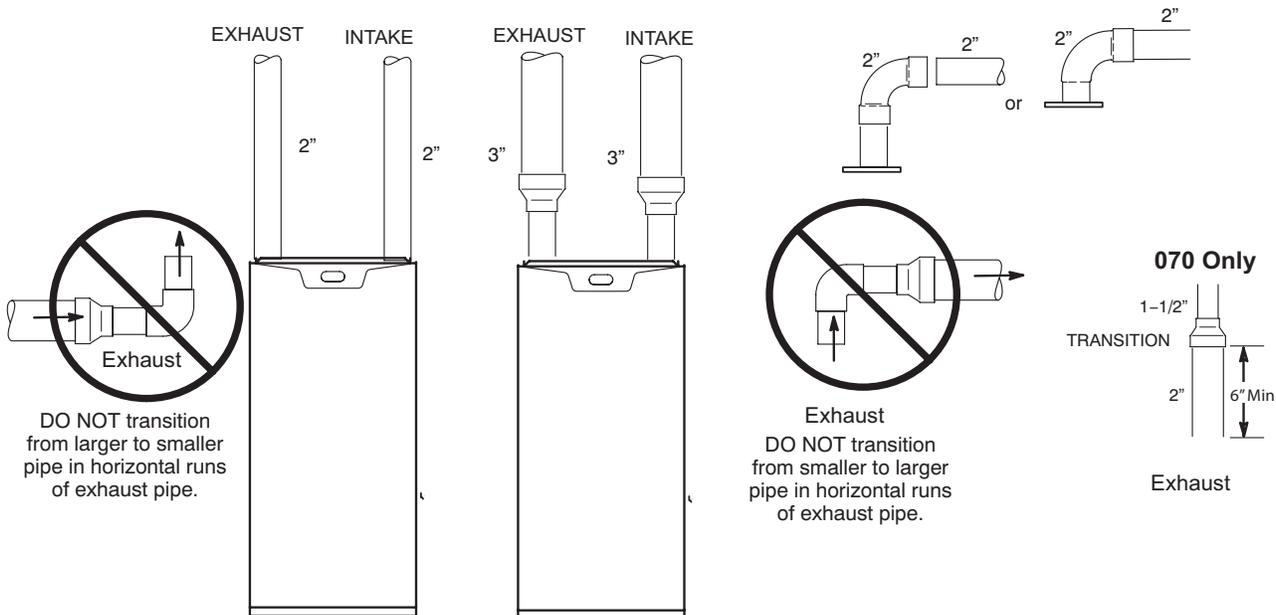

\* When transitioning up in pipe size, use the shortest length of 2" PVC pipe possible.  
NOTE - Exhaust pipe and intake pipe must be the same diameter.

**FIGURE 26**

**TYPICAL EXHAUST AND INTAKE PIPE CONNECTIONS IN HORIZONTAL  
(RIGHT HAND DISCHARGE SHOWN)**

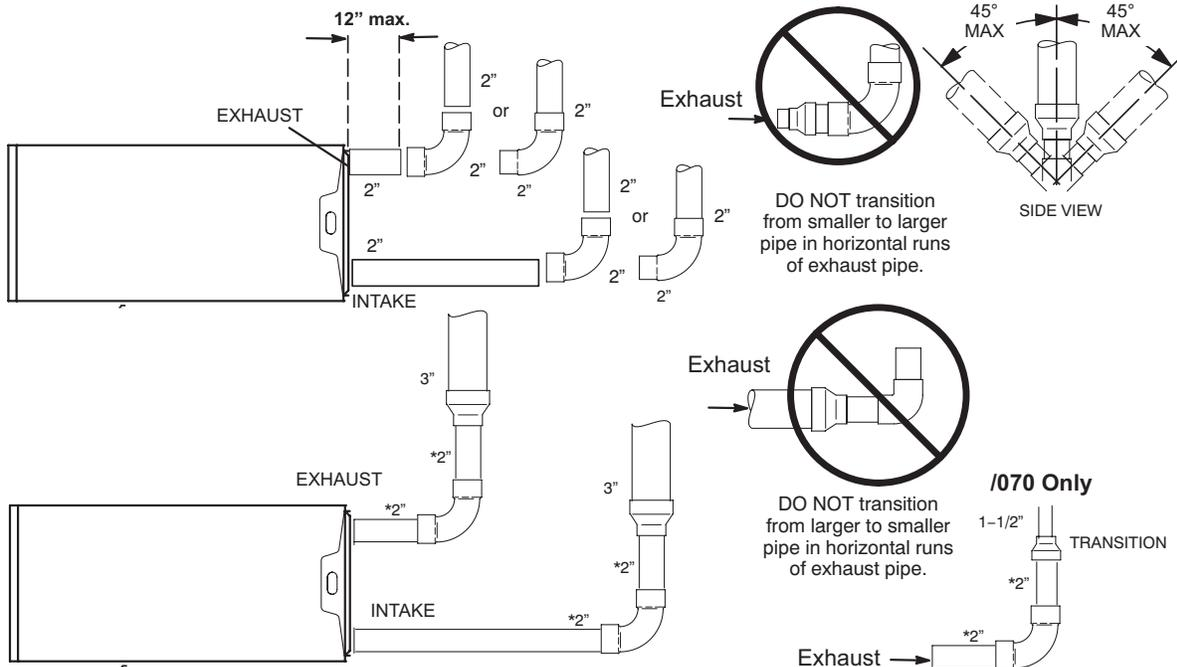

\* When transitioning up in pipe size, use the shortest length of 2" PVC pipe possible.  
NOTE - Exhaust pipe and intake pipe must be the same diameter.

**FIGURE 27**

## VENT TERMINATION CLEARANCES FOR DIRECT VENT INSTALLATIONS IN THE USA AND CANADA

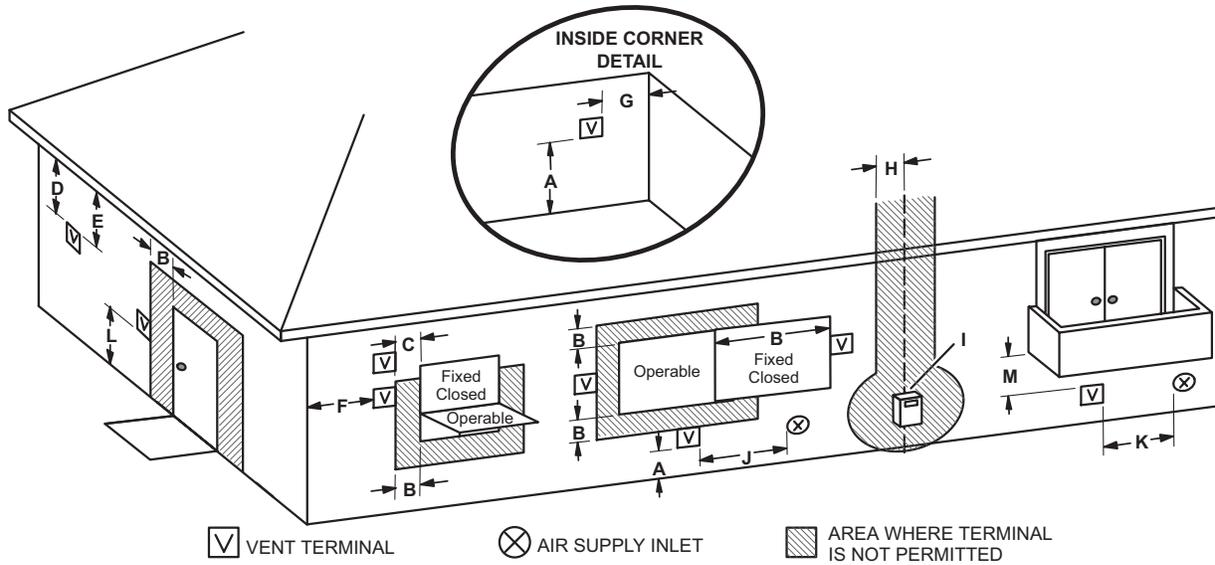

	US Installations <sup>1</sup>	Canadian Installations <sup>2</sup>	
A =	Clearance above grade, veranda, porch, deck or balcony	12 inches (305mm) or 12 in. (305mm) above average snow accumulation.	12 inches (305mm) or 12 in. (305mm) above average snow accumulation.
B =	Clearance to window or door that may be opened	6 inches (152mm) for appliances <10,000 Btuh (3kw), 9 inches (228mm) for appliances > 10,000 Btuh (3kw) and <50,000 Btuh (15 kw), 12 inches (305mm) for appliances > 50,000 Btuh (15kw)	6 inches (152mm) for appliances <10,000 Btuh (3kw), 12 inches (305mm) for appliances > 10,000 Btuh (3kw) and <100,000 Btuh (30kw), 36 inches (.9m) for appliances > 100,000 Btuh (30kw)
C =	Clearance to permanently closed window	* 12"	* 12"
D =	Vertical clearance to ventilated soffit located above the terminal within a horizontal distance of 2 feet (610mm) from the center line of the terminal	* Equal to or greater than soffit depth	* Equal to or greater than soffit depth
E =	Clearance to unventilated soffit	* Equal to or greater than soffit depth	* Equal to or greater than soffit depth
F =	Clearance to outside corner	* No minimum to outside corner	* No minimum to outside corner
G =	Clearance to inside corner	*	*
H =	Clearance to each side of center line extended above meter / regulator assembly	3 feet (.9m) within a height 15 feet (4.5m) above the meter / regulator assembly	3 feet (.9m) within a height 15 feet (4.5m) above the meter / regulator assembly
I =	Clearance to service regulator vent outlet	* 3 feet (.9m)	3 feet (.9m)
J =	Clearance to non-mechanical air supply inlet to building or the combustion air inlet to any other appliance	6 inches (152mm) for appliances <10,000 Btuh (3kw), 9 inches (228mm) for appliances > 10,000 Btuh (3kw) and <50,000 Btuh (15 kw), 12 inches (305mm) for appliances > 50,000 Btuh (15kw)	6 inches (152mm) for appliances <10,000 Btuh (3kw), 12 inches (305mm) for appliances > 10,000 Btuh (3kw) and <100,000 Btuh (30kw), 36 inches (.9m) for appliances > 100,000 Btuh (30kw)
K =	Clearance to mechanical air supply inlet	3 feet (.9m) above if within 10 feet (3m) horizontally	6 feet (1.8m)
L =	Clearance above paved sidewalk or paved driveway located on public property	* 7 feet (2.1m)	7 feet (2.1m)†
M =	Clearance under veranda, porch, deck or balcony	*12 inches (305mm)‡	12 inches (305mm)‡

<sup>1</sup> In accordance with the current ANSI Z223.1/NFPA 54 Natural Fuel Gas Code

<sup>2</sup> In accordance with the current CSA B149.1, Natural Gas and Propane Installation Code

† A vent shall not terminate directly above a sidewalk or paved driveway that is located between two single family dwellings and serves both dwellings.

‡ Permitted only if veranda, porch, deck or balcony is fully open on a minimum of two sides beneath the floor. Lennox recommends avoiding this location if possible.

\*For clearances not specified in ANSI Z223.1/NFPA 54 or CSA B149.1, clearance will be in accordance with local installation codes and the requirements of the gas supplier and these installation instructions."

**FIGURE 28**

## General Guidelines for Vent Terminations

In Direct Vent applications, combustion air is taken from outdoors and the flue gases are discharged to the outdoors. The SLP99UHV is classified as a direct vent, Category IV gas furnace.

In Direct Vent applications, the vent termination is limited by local building codes. In the absence of local codes, refer to the current National Fuel Gas Code ANSI Z223-1/NFPA 54 in U.S.A., and current CSA-B149 Natural Gas and Propane Installation Codes in Canada for details.

Position termination according to location given in FIGURE 28. In addition, position termination so it is free from any obstructions and 12" above the average snow accumulation.

At vent termination, care must be taken to maintain protective coatings over building materials (prolonged exposure to exhaust condensate can destroy protective coatings). It is recommended that the exhaust outlet not be located within 6 feet (1.8m) of a condensing unit because the condensate can damage the painted coating.

**NOTE** - See TABLE 25 for maximum allowed exhaust pipe length without insulation in unconditioned space during winter design temperatures below 32°F (0°C). If required exhaust pipe should be insulated with 1/2" (13mm) Armaflex or equivalent. In extreme cold climate areas, 3/4" (19mm) Armaflex or equivalent may be necessary. Insulation must be protected from deterioration. Armaflex with UV protection is permissible. Basements or other enclosed areas that are not exposed to the outdoor ambient temperature and are above 32 degrees F (0°C) are to be considered conditioned spaces.

### IMPORTANT

Do not use screens or perforated metal in exhaust or intake terminations. Doing so will cause freeze-ups and may block the terminations.

### IMPORTANT

For Canadian Installations Only:  
In accordance to CSA International B149 installation codes, the minimum allowed distance between the combustion air intake inlet and the exhaust outlet of other appliances shall not be less than 12 inches (305mm).

**TABLE 25**  
**Maximum Allowable Vent Pipe Length (in ft.<sup>3</sup>) Without Insulation In Unconditioned Space**  
**For Winter Design Temperatures Modulating High Efficiency Furnace**

Winter Design Temperatures <sup>1</sup> °F (°C)	Vent Pipe Diameter	Unit Input Size							
		070		090		110		135	
32 to 21 (0 to -6)		PVC	<sup>2</sup> PP	PVC	<sup>2</sup> PP	PVC	<sup>2</sup> PP	PVC	<sup>2</sup> PP
	1-1/2 in.	N/A	N/A	N/A	N/A	N/A	N/A	N/A	N/A
	2 in.	11	9	14	12	18	15		
	2-1/2 in.	7	N/A	10	N/A	12	N/A		
	3 in.	2	2	6	6	8	8	13	13
20 to 1 (-7 to -17)	1-1/2 in.	N/A	N/A	N/A	N/A	N/A	N/A	N/A	N/A
	2 in.	3	1	6	4	8	6		
	2-1/2 in.	1	N/A	1	N/A	3	N/A		
	3 in.	1	1	1	1	1	1	2	2
0 to -20 (-18 to -29)	1-1/2 in.	N/A	N/A	N/A	N/A	N/A	N/A	N/A	N/A
	2 in.	1	1	1	1	2	1		
	2-1/2 in.	1	N/A	1	N/A	1	N/A		
	3 in.	1	1	1	1	N/A			

<sup>1</sup>Refer to 99% Minimum Design Temperature table provided in the current edition of the ASHRAE Fundamentals Handbook.

<sup>2</sup> Poly-Propylene vent pipe (PP) by Duravent and Centrotherm.

<sup>3</sup> Vent lengths in table are *equivalent* length. Consider each elbow as 5ft of *linear* length.

NOTE - Concentric terminations are the equivalent of 5' and should be considered when measuring pipe length.

NOTE - Maximum uninsulated vent lengths listed may include the termination (vent pipe exterior to the structure) and cannot exceed 5 linear feet or the maximum allowable intake or exhaust vent length listed in TABLE 24 or which ever is less.

NOTE - If insulation is required in an unconditioned space, it must be located on the pipe closest to the furnace. FIGURE 29.

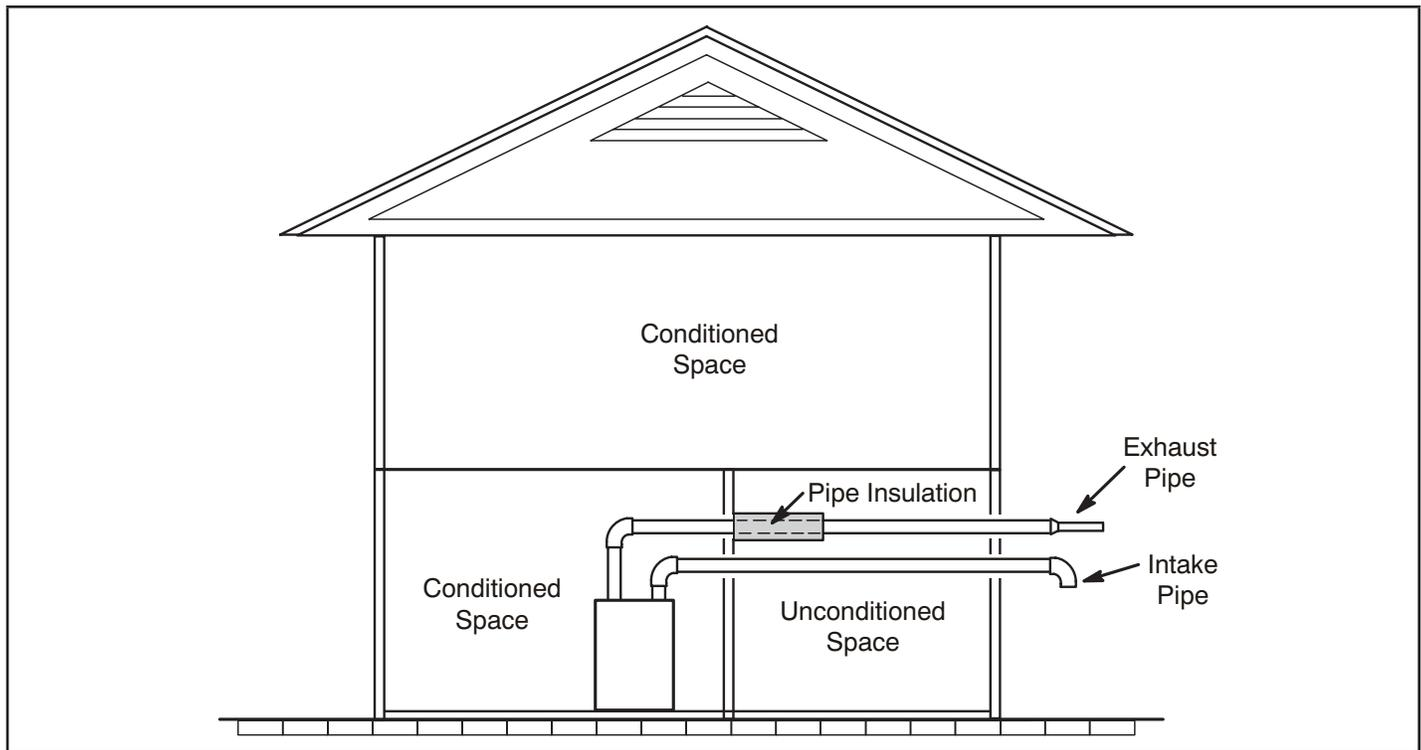

FIGURE 29

### Details of Intake and Exhaust Piping Terminations for Direct Vent Installations

**NOTE** - In Direct Vent installations, combustion air is taken from outdoors and flue gases are discharged to outdoors.

**NOTE** - Flue gas may be slightly acidic and may adversely affect some building materials. If any vent termination is used and the flue gasses may impinge on the building material, a corrosion-resistant shield (minimum 24 inches square) should be used to protect the wall surface. If the optional tee is used, the protective shield is recommended. The shield should be constructed using wood, plastic, sheet metal or other suitable material. All seams, joints, cracks, etc. in the affected area should be sealed using an appropriate sealant. See FIGURE 33.

Intake and exhaust pipes may be routed either horizontally through an outside wall or vertically through the roof. In attic or closet installations, vertical termination through the roof is preferred. FIGURE 31 through FIGURE 39 show typical terminations.

- 1 - Intake and exhaust terminations are not required to be in the same pressure zone. You may exit the intake on one side of the structure and the exhaust on another side (FIGURE 32). You may exit the exhaust out the roof and the intake out the side of the structure (FIGURE 32).
- 2 - Intake and exhaust pipes should be placed as close together as possible at termination end (refer to illustrations). Maximum separation is 3" (76mm) on roof terminations and 6" (152mm) on side wall terminations.

**NOTE** - When venting in different pressure zones, the maximum separation requirement of intake and exhaust pipe DOES NOT apply.

- 3 - On roof terminations, the intake piping should terminate straight down using two 90° elbows (See FIGURE 30).
- 4 - Exhaust piping must terminate straight out or up as shown. A reducer may be required on the exhaust piping at the point where it exits the structure to improve the velocity of exhaust away from the intake piping. See TABLE 26.

**NOTE** - Care must be taken to avoid recirculation of exhaust back into intake pipe.

TABLE 26

EXHAUST PIPE TERMINATION SIZE REDUCTION	
SLP99UHV Model	Termination Pipe Size
*070	1-1/2"
*090	2"
110	2"
135	2"

\*SLP99UH-070 and -090 units with the flush-mount termination must use the 1-1/2" accelerator supplied with the kit.

- 5 - On field-supplied terminations for side wall exit, exhaust piping may extend a maximum of 12 inches (305mm) for 2" PVC and 20 inches (508mm) for 3" (76mm) PVC beyond the outside wall. Intake piping should be as short as possible. See FIGURE 34.
- 6 - On field-supplied terminations, a minimum distance between the end of the exhaust pipe and the end of the intake pipe without a termination elbow is 8" and a minimum distance of 6" with a termination elbow. See FIGURE 34.

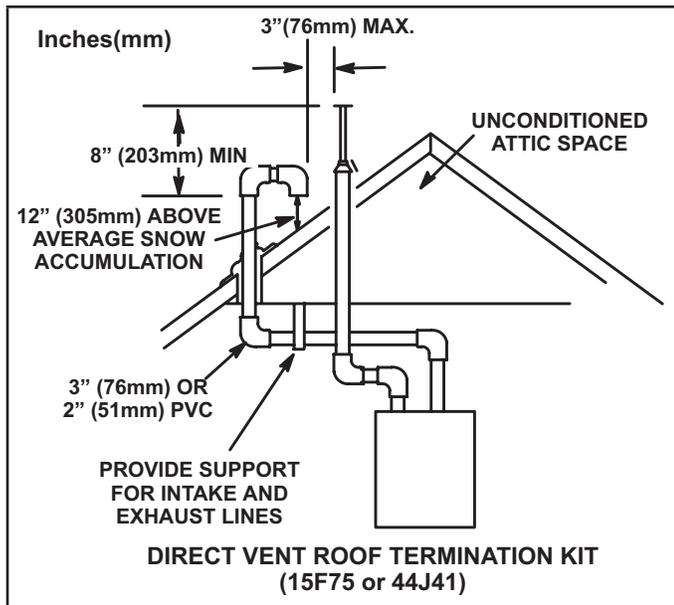

**FIGURE 30**

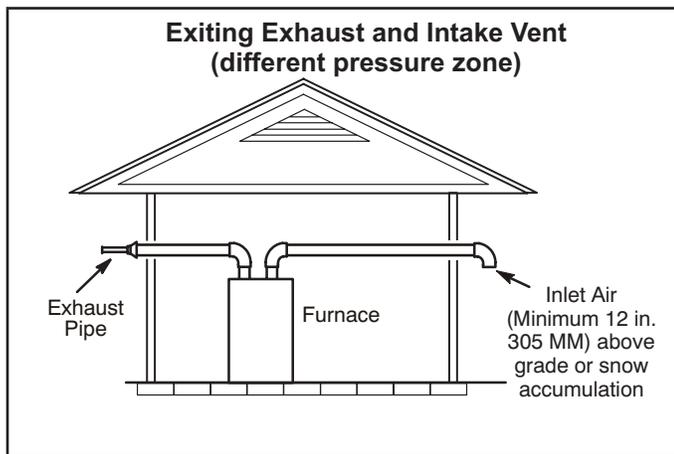

**FIGURE 31**

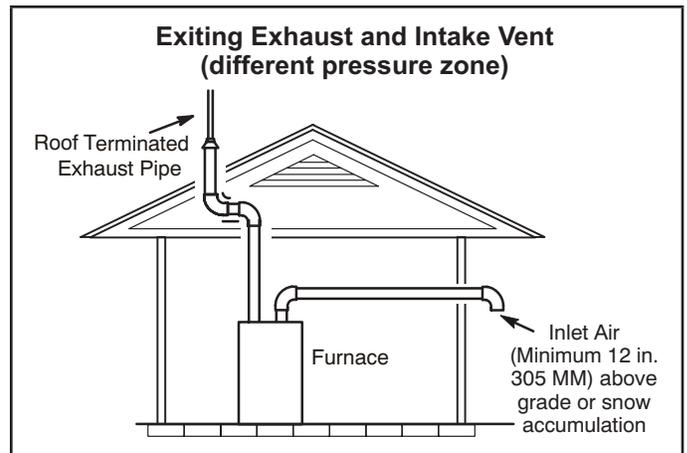

**FIGURE 32**

- 7 - If intake and exhaust piping must be run up a side wall to position above snow accumulation or other obstructions, piping must be supported. At least one bracket must be used within 6" from the top of the elbow and then every 24" (610mm) as shown in FIGURE 33, to prevent any movement in any direction. When exhaust and intake piping must be run up an outside wall, the exhaust piping must be terminated with pipe sized per table 26. The intake piping may be equipped with a 90° elbow turndown. Using turndown will add 5 feet (1.5m) to the equivalent length of the pip
- 8 - Based on the recommendation of the manufacturer, a multiple furnace installation may use a group of up to four terminations assembled together horizontally, as shown in FIGURE 36.



NOTE - FIELD-PROVIDED REDUCER MAY BE REQUIRED TO ADAPT LARGER VENT PIPE SIZE TO TERMINATION

**FIELD FABRICATED WALL TERMINATION**

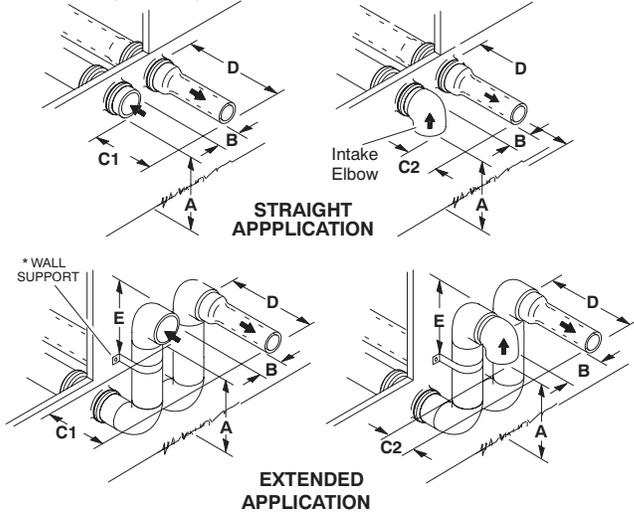

	2" (51mm) Vent Pipe	3" (76mm) Vent Pipe
<b>A</b> - Minimum clearance above grade or average snow accumulation	12" (305 mm)	12" (305 mm)
<b>B</b> - Maximum horizontal separation between intake and exhaust	6" (152 mm)	6" (152 mm)
<b>C1</b> - Minimum from end of exhaust to inlet of intake	8" (203 mm)	8" (203 mm)
<b>C2</b> - Minimum from end of exhaust to inlet of intake	6" (152 mm)	6" (152 mm)
<b>D</b> - Maximum exhaust pipe length	12" (305 mm)	20" (508 mm)
<b>E</b> - Maximum wall support distance from top of each pipe (intake/exhaust)	6" (152 mm)	6" (152 mm)

See maximum allowable venting tables for venting lengths with this arrangement.  
 \* Use wall support every 24" (610 mm). Use two wall supports if extension is greater than 24" (610 mm) but less than 48" (1219 mm).  
 NOTE - One wall support must be within 6" (152 mm) from top of each pipe (intake and exhaust) to prevent movement in any direction.

**ALTERNATE TERMINATIONS (TEE & FORTY-FIVE DEGREE ELBOWS ONLY)**

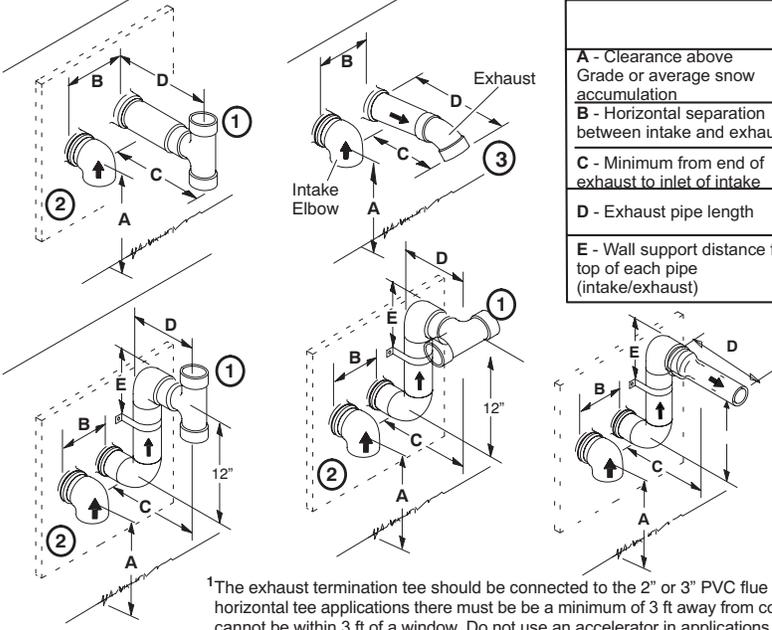

	2" (51mm) Vent Pipe	3" (76mm) Vent Pipe
<b>A</b> - Clearance above Grade or average snow accumulation	12" (305 mm) Min	12" (305 mm) Min
<b>B</b> - Horizontal separation between intake and exhaust	6" (152mm)min 24" (610mm)Max	6" (152mm)min 24" (610mm)Max
<b>C</b> - Minimum from end of exhaust to inlet of intake	9" (227mm)	9" (227mm)
<b>D</b> - Exhaust pipe length	12" (305mm)min 16" (405mm)Max	12" (305mm)min 16" (405mm)Max
<b>E</b> - Wall support distance from top of each pipe (intake/exhaust)	6" (152mm) Max	6" (152mm) Max

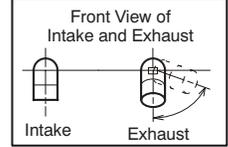

- The exhaust termination tee should be connected to the 2" or 3" PVC flue pipe as shown in the illustration. In horizontal tee applications there must be a minimum of 3 ft away from covered patios or any living areas and cannot be within 3 ft of a window. Do not use an accelerator in applications that include an exhaust termination tee. The accelerator is not required.
- As required. Flue gas may be acidic and may adversely affect some building materials. If a side wall termination is used and flue gases will impinge on the building materials, a corrosion-resistant shield (24 inches square) should be used to protect the wall surface. If optional tee is used, the protective shield is recommended. The shield should be constructed using wood, sheet metal or other suitable material. All seams, joints, cracks, etc. in affected area, should be sealed using an appropriate sealant.
- Exhaust pipe 45° elbow can be rotated to the side away from the combustion air inlet to direct exhaust away from adjacent property. The exhaust must never be directed toward the combustion air inlet.

**FIGURE 33**

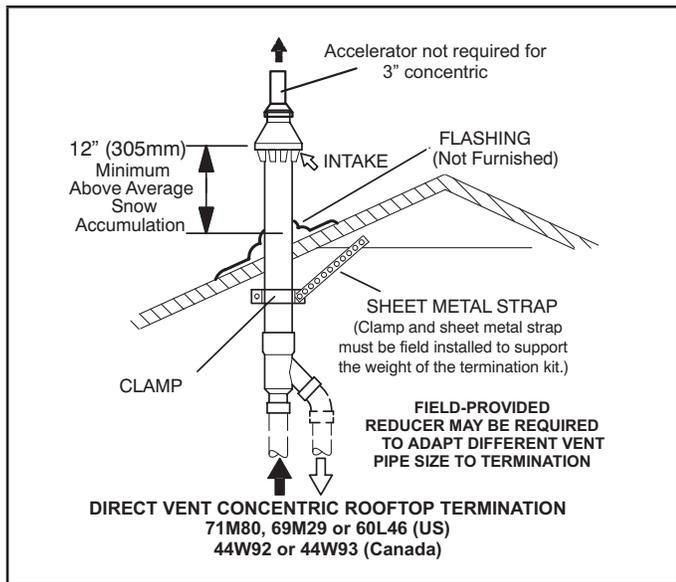

FIGURE 34

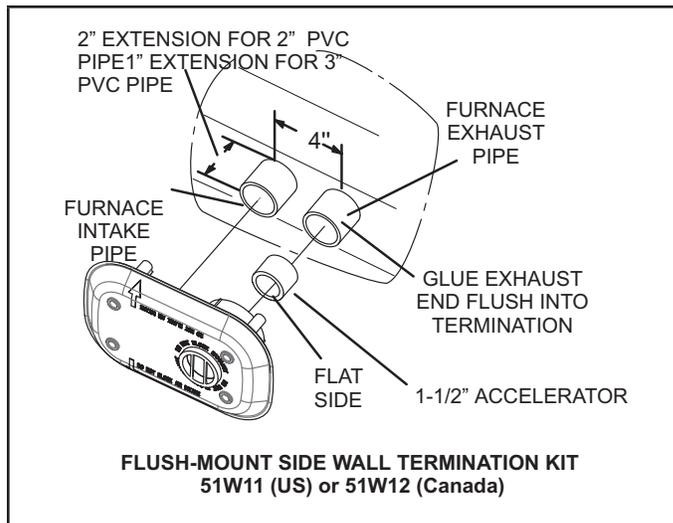

FIGURE 37

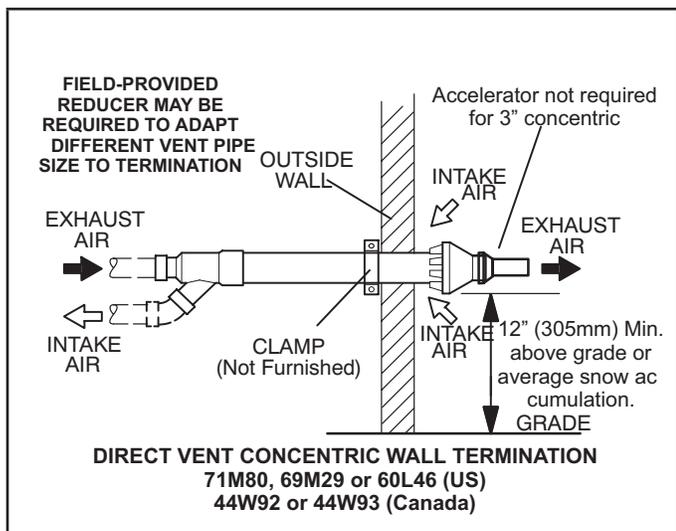

FIGURE 35

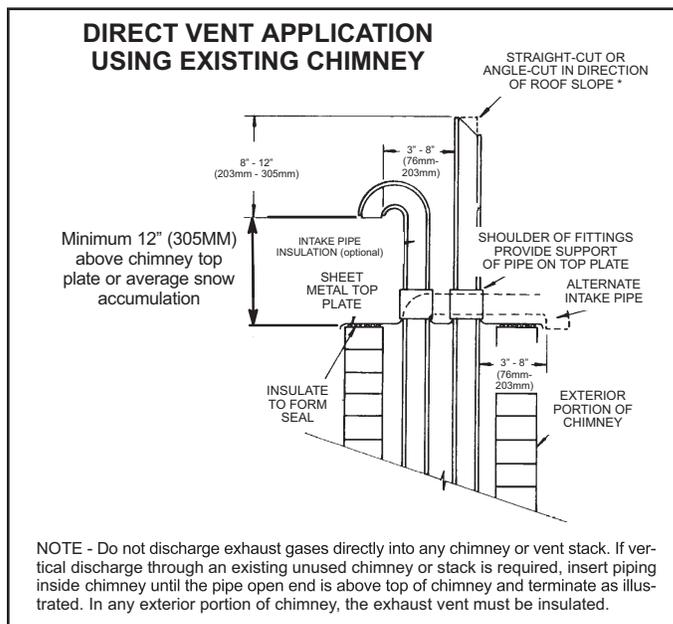

FIGURE 38

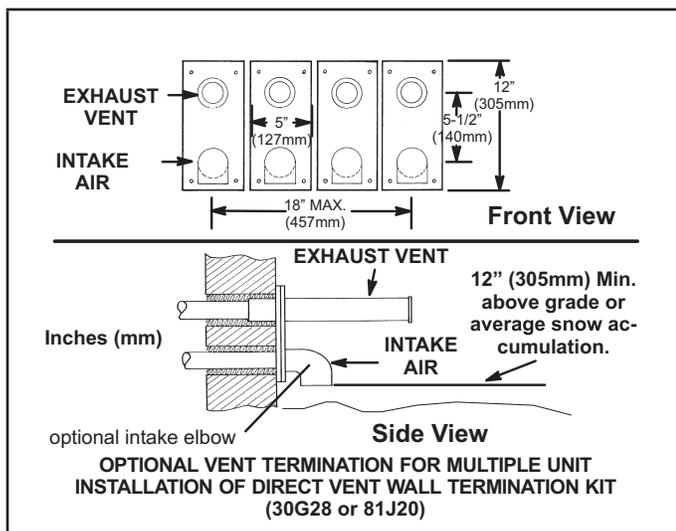

FIGURE 36

## Condensate Piping

This unit is designed for either right- or left-side exit of condensate piping in upflow applications. In horizontal applications, the condensate trap must extend below the unit. An 8" service clearance is required for the condensate trap. Refer to FIGURE 39 and FIGURE 41 for condensate trap locations. FIGURE 47 shows trap assembly.

**NOTE** - If necessary the condensate trap may be installed up to 5' away from the furnace. Use PVC pipe to connect trap to furnace condensate outlet. Piping from furnace must slope down a minimum of 1/4" per ft. toward trap.

- 1 - Determine which side condensate piping will exit the unit, location of trap, field-provided fittings and length of PVC pipe required to reach available drain.
- 2 - For furnaces with a 1/2" drain connection use a 3/8 allen wrench and remove plug (FIGURE 40) from the cold end header box at the appropriate location. Install field-provided 1/2 NPT male fitting into cold end header box. For furnaces with a 3/4" drain connection use a large flat head screw driver or a 1/2" drive socket extension and remove plug. Install provided 3/4 NPT street elbow fitting into cold end header box. Use Teflon tape or appropriate pipe dope
- 3 - Install the cap over the clean out opening at the base of the trap. Secure with clamp. See FIGURE 47.
- 4 - Install drain trap using appropriate PVC fittings, glue all joints. Glue the provided drain trap as shown in FIGURE 47. Route the condensate line to an open drain. Condensate line must maintain a 1/4" downward slope from the furnace to the drain.
- 5 - FIGURE 43 and FIGURE 44 show the furnace and evaporator coil using a separate drain. If necessary the condensate line from the furnace and evaporator coil can drain together. See FIGURE 42, FIGURE 45 and FIGURE 46. *Upflow furnace (FIGURE 45)* - In upflow furnace applications the field provided vent must be a minimum 1" to a maximum 2" length above the condensate drain outlet connection. Any length above 2" may result in a flooded heat exchanger if the combined primary drain line were to become restricted. *Horizontal furnace (FIGURE 46)* - In horizontal furnace applications the field provided vent must be a minimum 4" to a maximum 5" length above the condensate drain outlet connection. Any length above 5" may result in a flooded heat exchanger if the combined primary drain line were to become restricted.
- 6 - If unit will be started immediately upon completion of installation, prime trap per procedure outlined in Unit Start-Up section.

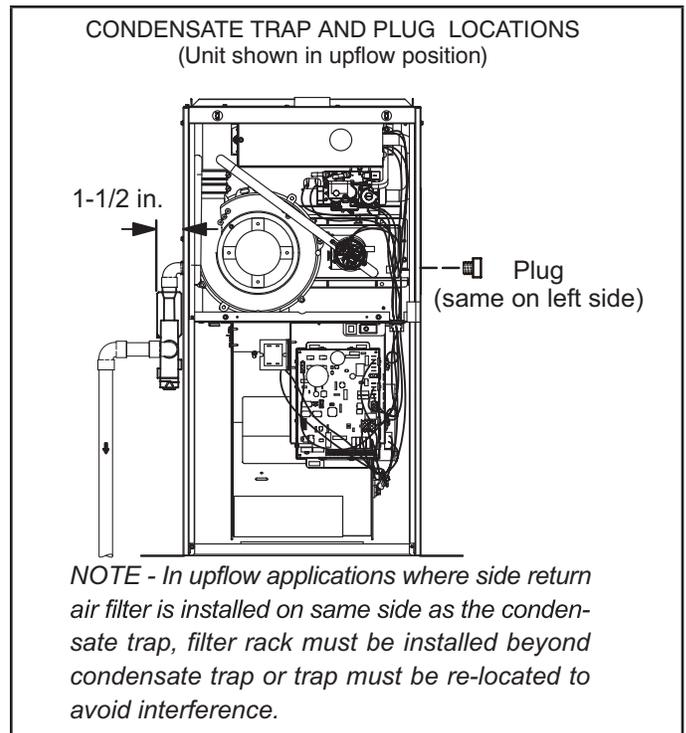

**FIGURE 39**

**NOTE** - In horizontal applications it is recommended to install a secondary drain pan underneath the unit and trap assembly.

**NOTE** - Appropriately sized tubing and barbed fitting may be used for condensate drain. Attach to the drain on the trap using a hose clamp. See FIGURE 40.

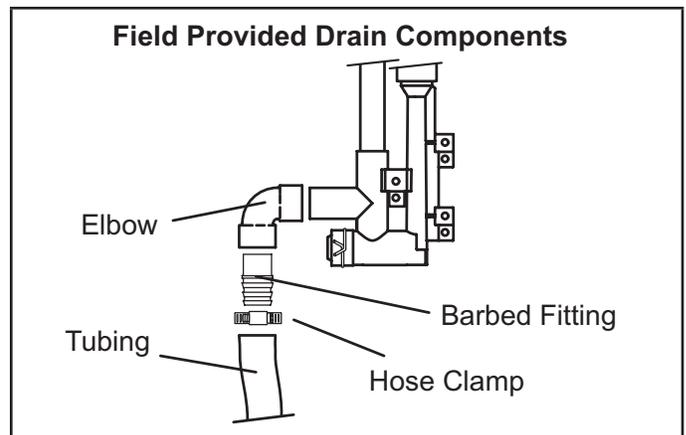
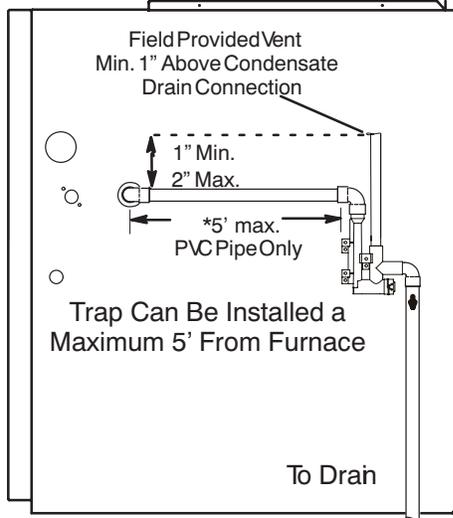

**FIGURE 40**

Condensate line must slope downward away from the trap to drain. If drain level is above condensate trap, condensate pump must be used. Condensate drain line should be routed within the conditioned space to avoid freezing of condensate and blockage of drain line. If this is not possible, a heat cable kit may be used on the condensate trap and line. Heating cable kit is available from Lennox in various lengths; 6 ft. (1.8m) - kit no. 26K68 and 24 ft. (7.3m) - kit no. 26K69.

### CONDENSATE TRAP LOCATIONS

(Unit shown in upflow position with remote trap)



\*Piping from furnace must slope down a minimum 1/4" per ft. toward trap

FIGURE 41

### Furnace With Evaporator Coil Using A Separate Drain

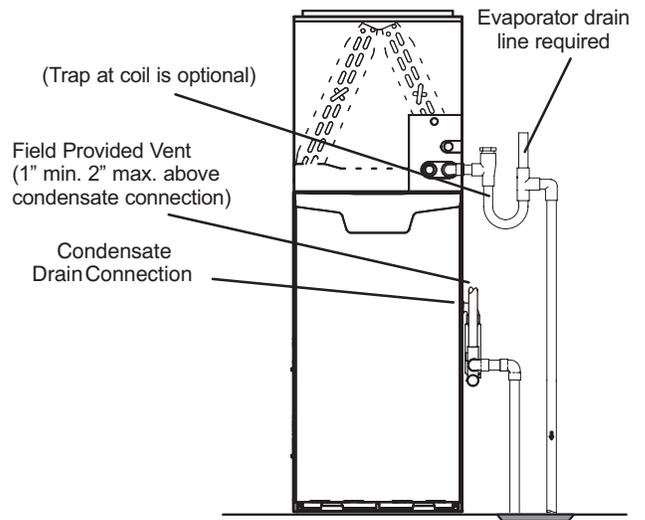

FIGURE 43

### Condensate Trap With Optional Overflow Switch

From Evaporator Coil

Field-Provided Vent  
(Upflow/Furnace 1" Min. to 2" Max.  
Horizontal Furnace 4" Min. to 5" Max. above  
condensate drain connection)

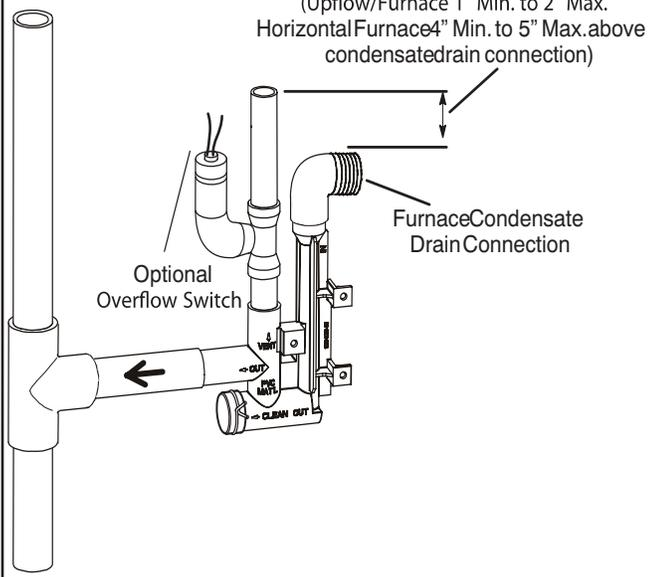
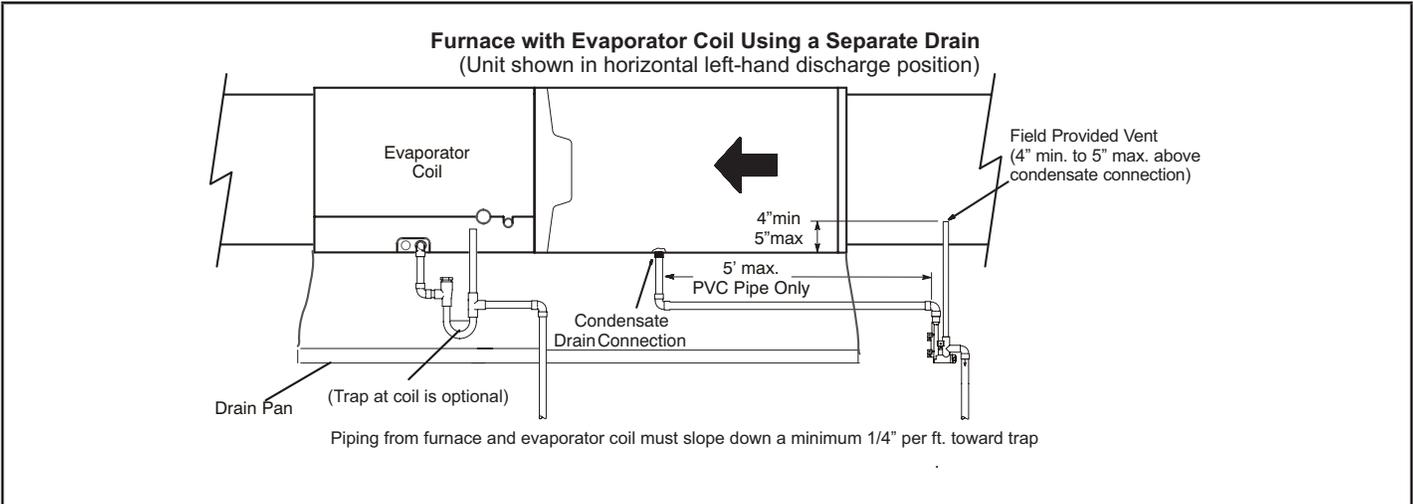
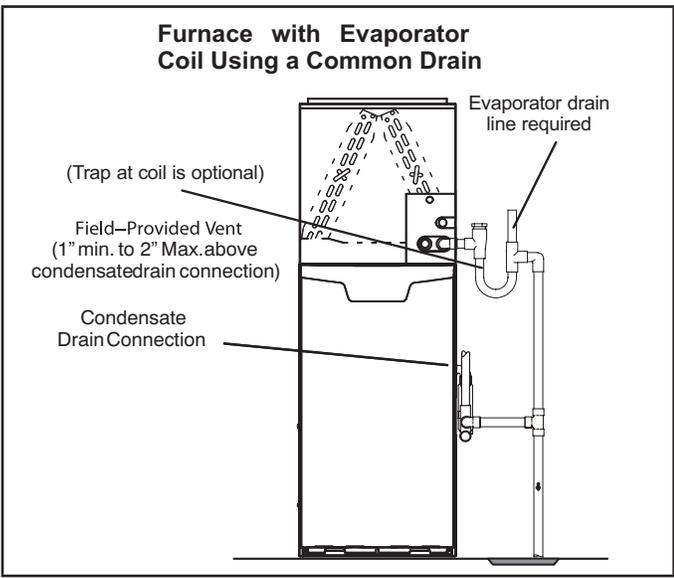

FIGURE 42



**FIGURE 44**



**FIGURE 45**

**⚠ IMPORTANT**

When combining the furnace and evaporator coil drains together, the A/C condensate drain outlet must be vented to relieve pressure in order for the furnace pressure switch to operate properly.

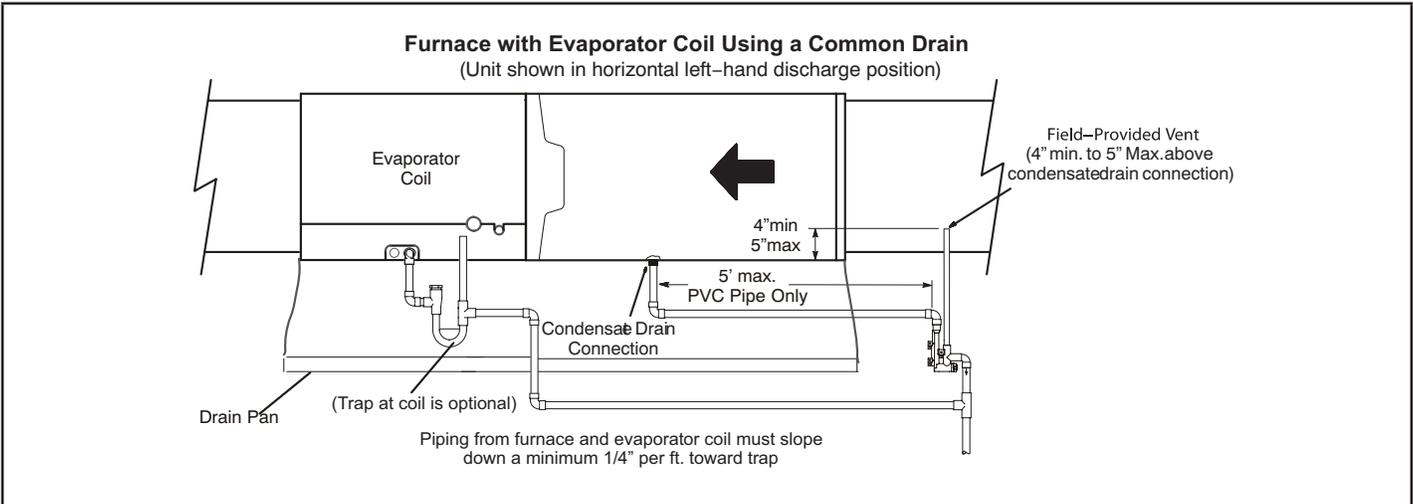

**FIGURE 46**

**TRAP / DRAIN ASSEMBLY USING 1/2" PVC OR 3/4" PVC**

Optional Condensate Drain Connection

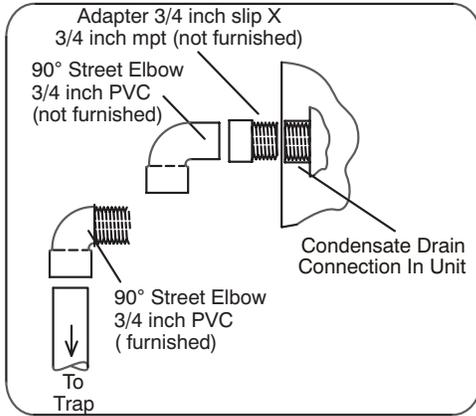

Optional Drain Piping From Trap

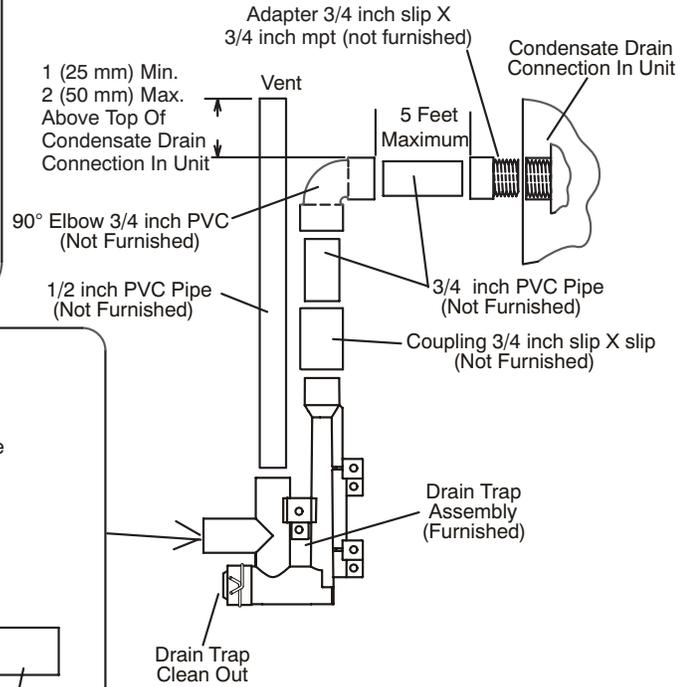
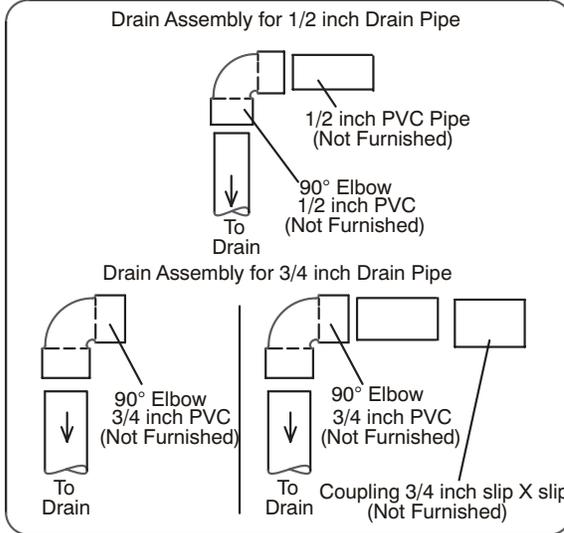

Drain Trap Assembly (Furnished)

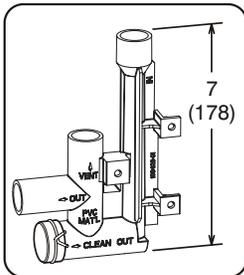

Drain Trap Assembly with 1/2 inch Piping

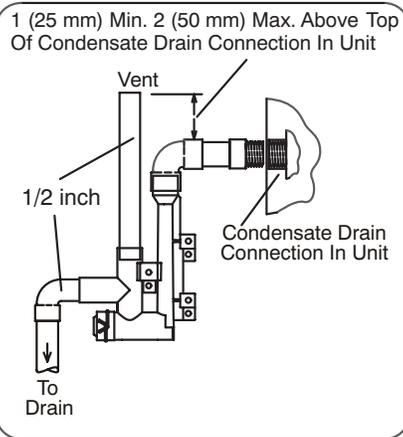

Drain Trap Assembly with 3/4 inch Piping

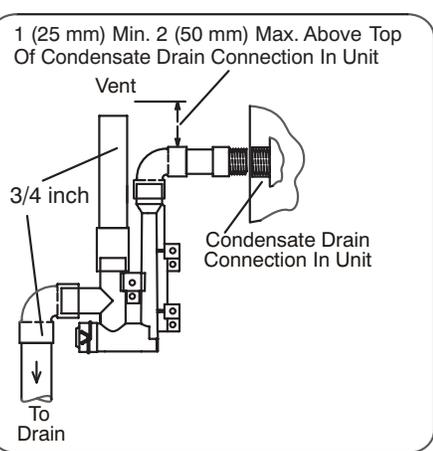

**FIGURE 47**

## IV-START-UP

### A-Preliminary and Seasonal Checks

- 1 - Inspect electrical wiring, both field and factory installed for loose connections. Tighten as required.
- 2 - Check voltage at disconnect switch. Voltage must be within range listed on the nameplate. If not, consult the power company and have voltage condition corrected before starting unit.

### B-Heating Start-Up

FOR YOUR SAFETY READ BEFORE OPERATING

#### **⚠ WARNING**

Do not use this furnace if any part has been underwater. A flood-damaged furnace is extremely dangerous. Attempts to use the furnace can result in fire or explosion. Immediately call a qualified service technician to inspect the furnace and to replace all gas controls, control system parts, and electrical parts that have been wet or to replace the furnace, if deemed necessary.

#### **⚠ WARNING**

Danger of explosion. Can cause injury or product or property damage. Should the gas supply fail to shut off or if overheating occurs, shut off the gas valve to the furnace before shutting off the electrical supply.

#### **⚠ CAUTION**

Before attempting to perform any service or maintenance, turn the electrical power to unit OFF at disconnect switch.

### Priming Condensate Trap

The condensate trap should be primed with water prior to start-up to ensure proper condensate drainage. Either pour 10 fl. oz. (300 ml) of water into the trap, or follow these steps to prime the trap:

- 1 - Follow the lighting instructions to place the unit into operation.
- 2 - Set the thermostat to initiate a heating demand.
- 3 - Allow the burners to fire for approximately 3 minutes.
- 4 - Adjust the thermostat to deactivate the heating demand.
- 5 - Wait for the combustion air inducer to stop. Set the thermostat to initiate a heating demand and again allow the burners to fire for approximately 3 minutes.
- 6 - Adjust the thermostat to deactivate the heating demand and again wait for the combustion air inducer to stop. At this point, the trap should be primed with sufficient water to ensure proper condensate drain operation.

**BEFORE PLACING THE UNIT INTO OPERATION**, the unit, smell all around the furnace area for gas. Be sure to smell next to the floor because some gas is heavier than air and will settle on the floor.

The gas valve on the SLP99UHV is equipped with a gas control switch. Use only your hand to move the control switch. Never use tools. If the switch will not move by hand, do not try to repair it. Force or attempted repair may result in a fire or explosion.

### Placing the furnace into operation:

SLP99UHV units are equipped with an automatic ignition system. Do not attempt to manually light burners on this furnace. Each time the thermostat calls for heat, the burners will automatically light. The ignitor does not get hot when there is no call for heat on units with this ignition system.

#### **⚠ WARNING**

If you do not follow these instructions exactly, a fire or explosion may result causing property damage, personal injury or death.

### Gas Valve Operation (FIGURE 48)

- 1 - STOP! Read the safety information at the beginning of this section.
- 2 - Set the thermostat to the lowest setting.
- 3 - Turn off all electrical power to the unit.
- 4 - This furnace is equipped with an ignition device which automatically lights the burners. Do not try to light the burners by hand.
- 5 - Remove the upper access panel.
- 6 - Move the gas valve switch to the OFF position. See FIGURE 48.
- 7 - Wait five minutes to clear out any gas. If you then smell gas, STOP! Immediately call your gas supplier from a neighbor's phone. Follow the gas supplier's instructions. If you do not smell gas go to next step.

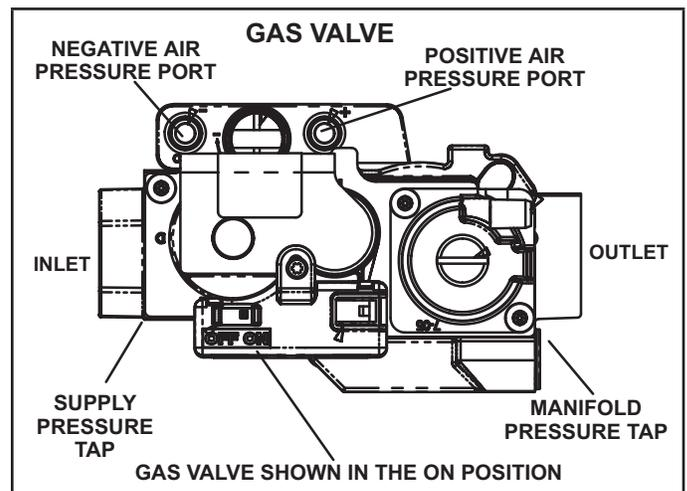

FIGURE 48

- 8 - Move gas valve switch to the ON position. See FIGURE 48. Do not force.
- 9 - Replace the upper access panel.
- 10 - Turn on all electrical power to the unit.
- 11 - Set the thermostat to desired setting.

**NOTE** - When unit is initially started, steps 1 through 11 may need to be repeated to purge air from gas line.

- 12 - If the appliance will not operate, follow the instructions "Turning Off Gas to Unit" and call your service technician or gas supplier.

#### Turning Off Gas to Unit

- 1 - Set the thermostat to the lowest setting.
- 2 - Turn off all electrical power to the unit if service is to be performed.
- 3 - Remove the upper access panel.
- 4 - Move the gas valve switch to the OFF position.
- 5 - Replace the upper access panel.

#### Failure To Operate

If the unit fails to operate, check the following:

- 1 - Is the thermostat calling for heat?
- 2 - Are access panels securely in place?
- 3 - Is the main disconnect switch closed?
- 4 - Is there a blown fuse?
- 5 - Is the filter dirty or plugged? Dirty or plugged filters will cause the limit control to shut the unit off.
- 6 - Is gas turned on at the meter?
- 7 - Is the manual main shut-off valve open?
- 8 - Is the gas valve turned on?
- 9 - Is the unit ignition system in lock out? If the unit locks out again, inspect the unit for blockages.
- 10 - Is blower harness connected to integrated control? Furnace will not operate unless harness is connected.

#### C-Safety or Emergency Shutdown

Turn off unit power. Close manual and main gas valves.

#### D-Extended Period Shutdown

Turn off thermostat or set to "UNOCCUPIED" mode. Close all gas valves (both internal and external to unit) to guarantee no gas leak into combustion chamber. Turn off power to unit. All access panels and covers must be in place and secured.

### V-HEATING SYSTEM SERVICE CHECKS

#### A-CSA Certification

All units are CSA design certified without modifications. Refer to the SLP99UHV Installation Instruction.

#### B-Gas Piping

**⚠ CAUTION**

If a flexible gas connector is required or allowed by the authority that has jurisdiction, black iron pipe shall be installed at the gas valve and extend outside the furnace cabinet. The flexible connector can then be added between the black iron pipe and the gas supply line.

**⚠ WARNING**

Do not over torque (800 in-lbs) or under torque (350 in-lbs) when attaching the gas piping to the gas valve.

Gas supply piping should not allow more than 0.5"W.C. drop in pressure between gas meter and unit. Supply gas pipe must not be smaller than unit gas connection.

Compounds used on gas piping threaded joints should be resistant to action of liquefied petroleum gases.

#### C-Testing Gas Piping

**⚠ IMPORTANT**

In case emergency shutdown is required, turn off the main shut-off valve and disconnect the main power to unit. These controls should be properly labeled by the installer.

When pressure testing gas lines, the gas valve must be disconnected and isolated. Gas valves can be damaged if subjected to more than 0.5psig (14" W.C.). See FIGURE 49.

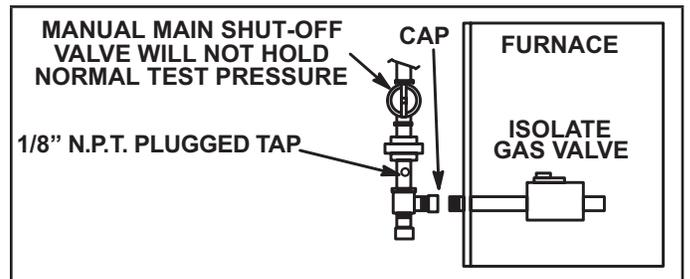

**FIGURE 49**

When checking piping connections for gas leaks, use preferred means. Kitchen detergents can cause harmful corrosion on various metals used in gas piping. Use of a specialty Gas Leak Detector is strongly recommended. It is available through Lennox under part number 31B2001. See Corp. 8411-L10, for further details.

Do not use matches, candles, flame or any other source of ignition to check for gas leaks.

#### D-Testing Gas Supply Pressure

When testing supply gas pressure, connect test gauge to supply pressure tap on the gas valve. See FIGURE 48. Check gas line pressure with unit firing at maximum rate. Low pressure may result in erratic operation or underfire. High pressure can result in permanent damage to gas valve or overfire. See TABLE 27 for operating pressure at unit gas connection (line).

On multiple unit installations, each unit should be checked separately, with and without units operating. Supply pressure must fall within range listed in TABLE 27.

**TABLE 27**

	Natural	LP/Propane
All Units		
Line Pressure WC"	4.5 - 10.5	11.0 - 13.0



## E- Proper Gas Flow (Approximate)

**TABLE 28**

GAS METER CLOCKING CHART				
SLP99 Unit	Seconds for One Revolution			
	Natural		LP	
	1 cu ft Dial	2 cu ft Dial	1 cu ft Dial	2 cu ft Dial
-070	55	110	136	272
-090	41	82	102	204
-110	33	66	82	164
-135	27	54	68	136
Natural-1000 btu/cu ft LP-2500 btu/cu ft				

Furnace should operate at least 5 minutes before checking gas flow. Determine time in seconds for two revolutions of gas through the meter. (Two revolutions assures a more accurate time.) Divide by two and compare to time in TABLE 28. If manifold pressure matches TABLE 32 and rate is incorrect, check gas orifices for proper size and restriction.

**NOTE** - To obtain accurate reading, shut off all other gas appliances connected to meter.

### F-Check Manifold Pressure (FIGURE 50)

To correctly measure manifold pressure, the differential pressure between the positive gas manifold and the negative burner box must be considered. Use pressure test adapter kit (available as Lennox part 10L34) to assist in measurement.

- 1 - Connect test gauge "+" connection to manifold pressure tap on the gas valve.
- 2 - Tee into the gas valve regulator vent hose and connect test gauge "-" connection.
- 3 - Start unit on low heat (35% rate) and allow 5 minutes for unit to reach steady state.

- 4 - While waiting for the unit to stabilize, notice the flame. Flame should be stable and should not lift from burner. Natural gas should burn blue.
- 5 - After allowing unit to run for 5 minutes, record manifold pressure and compare to value given in TABLE 32.
- 6 - Repeat steps 3, 4 and 5 on high fire.
- 7 - Shut unit off and remove manometer as soon as an accurate reading has been obtained. Take care to remove barbed fitting and replace threaded plug.
- 8 - Start unit and perform leak check. Seal leaks if found.

### G-Operating Pressure Signal (Delta P) Measurement (FIGURE 51)

Operating pressure signal can be taken while the manifold pressure check is taken (using two measuring devices). Or, taken after the manifold pressure measurement is complete.

- 1 - Tee into the negative line between the gas valve and pressure switch and connect to measuring device negative "-".
- 2 - Tee into the positive line between the gas valve and pressure switch and connect to measuring device positive "+".
- 3 - Start unit on low heat (35% rate) and allow 5 minutes for unit to reach steady state.
- 4 - After allowing unit to stabilize for 5 minutes, record operating pressure signal and compare to value given in TABLE 32.
- 5 - Repeat steps 3 on 4 high heat.

**MANIFOLD PRESSURE MEASUREMENT**

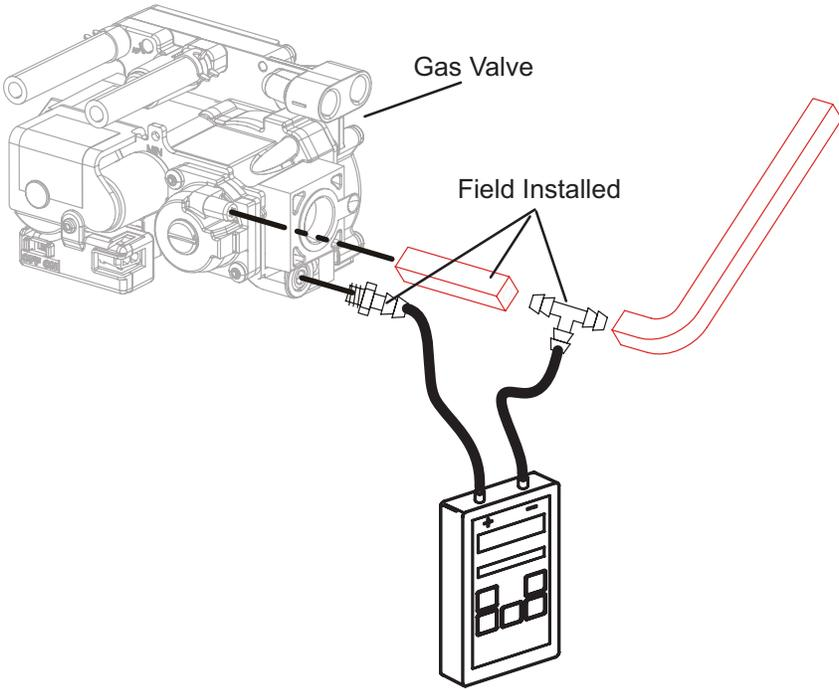

**FIGURE 50**

**Operating Signal (Delta P) Measurement**

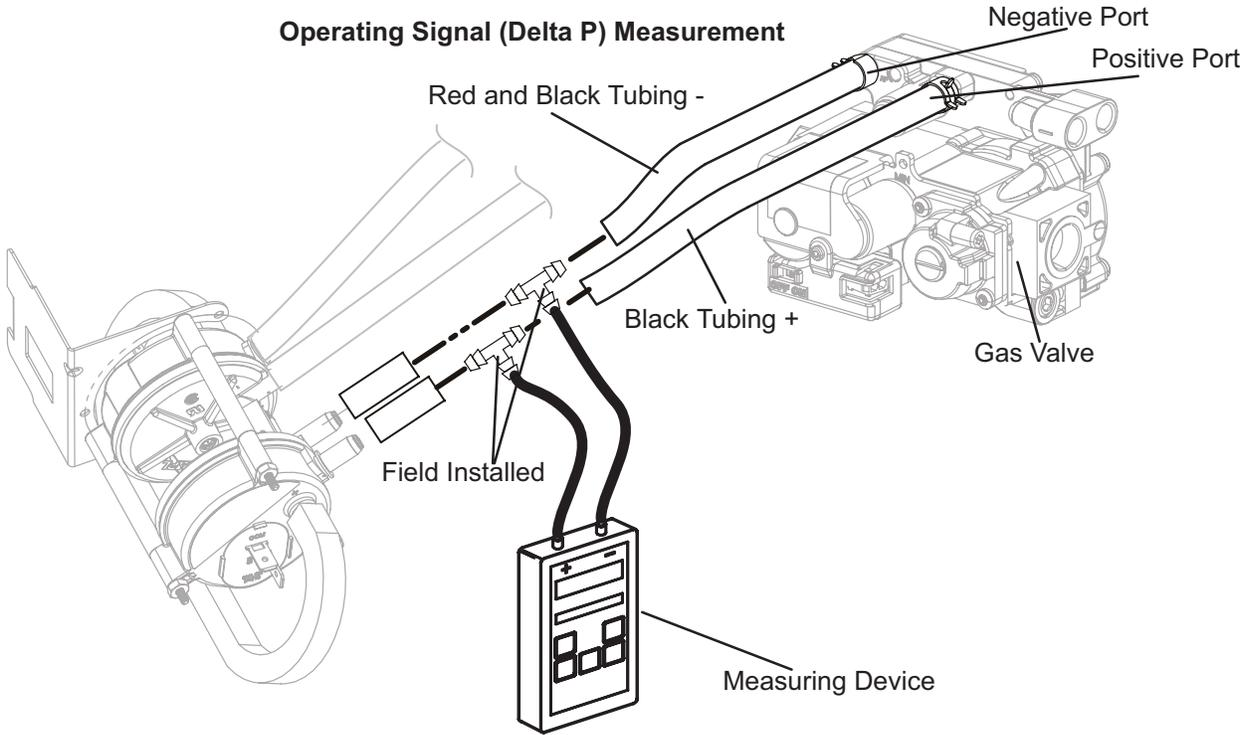

**FIGURE 51**

## H- Proper Combustion

Furnace should operate minimum 15 minutes with correct manifold pressure and gas flow rate before checking combustion. Take combustion sample beyond the flue outlet and compare to the tables below. **The maximum carbon monoxide reading should not exceed 100 ppm.**

**TABLE 29**  
**High Fire**

Unit	CO <sub>2</sub> % For Nat	CO <sub>2</sub> % For L.P.
-070	6.5 - 9.0	7.7 - 10.2
-09036C/48C		
-09060C	6.7 - 9.2	8.0 - 10.5
-110	6.5 - 9.0	7.7 - 10.2
-135		

**TABLE 30**  
**Low Fire**

Unit	CO <sub>2</sub> % For Nat	CO <sub>2</sub> % For L.P.
-070	4.7 - 7.2	5.7 - 8.2
-09036C/48C		
-09060C	5.3 - 7.8	
-110	4.7 - 7.2	
-135		

## I- High Altitude

**NOTE - In Canada, certification for installations at elevations over 4500 feet (1372 m) is the jurisdiction of local authorities.**

**SLP99UH09060C ONLY** requires a gas orifice change at altitudes from 4501 to 10,000 ft. All other model units require no manifold pressure adjustment nor a gas orifice change for operation at altitudes up to 10,000 feet (3048m) above sea level. Units installed at altitude of 7,501 to 10,000 feet (2287 to 3048m) require a pressure switch change per TABLE 31. TABLE 31 also lists gas conversion kit requirements at all altitudes.

The combustion air pressure switch is factory-set and requires no adjustment.

**TABLE 31**

**Conversion Kit & High Altitude Requirements**

Model Input	LP/Propane Conversion Kit		Natural Burner Kit
	0 - 4500 ft (0 - 1372m)	4501 - 10,000 ft (1372 3048m)	4501 - 10,000 ft (1372 3048m)
070	65W77	65W77	Not Required
090XV36C/48C			
090XV60C	20A26	20A88	20A89
110	65W77	65W77	Not Required
135			
Model Input	High Altitude Pressure Switch		
	0 - 7500 ft (0 - 2286m)	7501 - 10,000 ft (2286 - 3048m)	
070	Not Required	14T65	
090XV36C/48C		20A87	
090XV60C		14T65	
110			
135			

**TABLE 32**

Manifold and Operating Signal Pressures in inches 0 - 7500 ft (0 - 2286 m)

SLP99 Firing Rate	Manifold Pressure Natural Gas		Manifold Pressure LP/Propane		Operating Pressure Signal (Delta P)	
	Min	Max	Min	Max	Min	Max
Low	0.40	0.95	1.2	2.8	0.20	0.40
High	3.0	3.8	9.1	10.5	0.95	1.25
-090-060C Only	Min	Max	Min	Max	Min	Max
Low	0.30	0.85	----	----	0.15	0.35
Low	----	----	1.2	2.8	0.20	0.40
High	3.0	3.8	9.1	10.5	0.95	1.25

**NOTE - The values given in table are measurements only. The gas valve should NOT be adjusted.**  
**NOTE - A natural to LP/propane gas changeover kit is necessary to convert this unit. Refer to the changeover kit installation instruction for the conversion procedure.**

## J- Proper Ground and Voltage

A poorly grounded furnace can contribute to premature ignitor failure. Use the following procedure to check for ground and voltage to the integrated control.

- 1 - Measure the AC voltage between Line Neutral (spade terminals) and "C" terminal (low voltage terminal block) on the integrated control. See FIGURE 52. A wide variation in the voltage between Line Neutral and "C" as a function of load indicates a poor or partial ground. Compare the readings to TABLE 33. If the readings exceed the maximum shown in the table, make repairs before operating the furnace.

- 2 - In addition, measure the AC voltage from Line Hot to Line Neutral (spade terminals) on the integrated control. See FIGURE 52. This voltage should be in the range of 97 to 132 Vac.

**TABLE 33**

Furnace Status	Measurement VAC	
	Expected	Maximum
Power On Furnace Idle	0.3	2
CAI/Ignitor Energized	0.75	5
Indoor Blower Energized	Less than 2	10

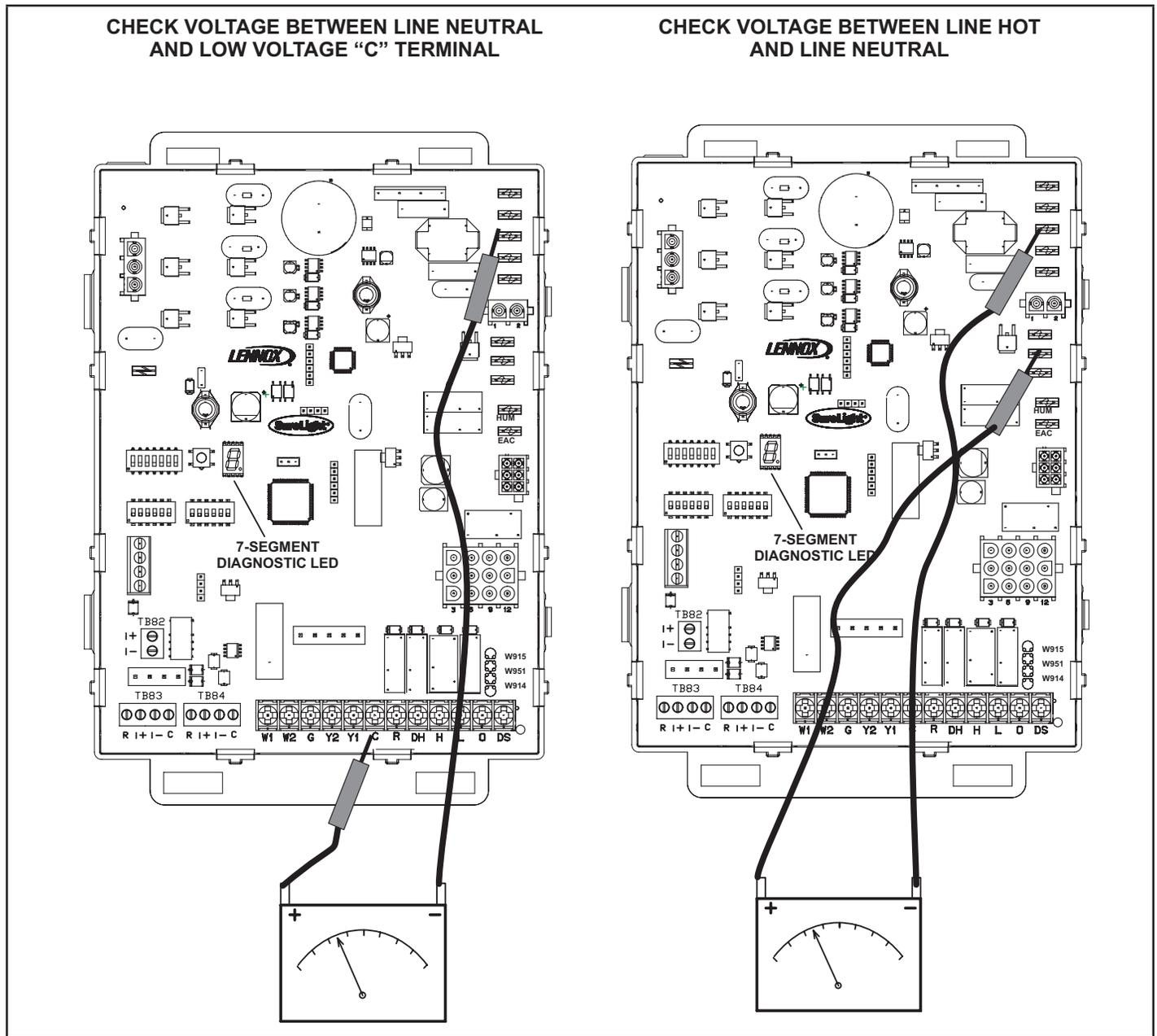

**FIGURE 52**

## VI-TYPICAL OPERATING CHARACTERISTICS

### A-Blower Operation and Adjustment

- 1 - Blower operation is dependent on thermostat control system.
- 2 - Generally, blower operation is set at thermostat subbase fan switch. With fan switch in ON position, blower operates continuously. With fan switch in AUTO position, blower cycles with demand or runs continuously while heating or cooling circuit cycles.
- 3 - Depending on the type of indoor thermostat, blower and entire unit will be off when the system switch is in OFF position.

### B-Temperature Rise

Temperature rise for SLP99UHV units depends on unit input, blower speed, blower horsepower and static pressure as marked on the unit rating plate. The blower speed must be set for unit operation within the range of "TEMP. RISE °F" listed on the unit rating plate.

#### To Measure Temperature Rise:

- 1 - Place plenum thermometers in the supply and return air plenums. Locate supply air thermometer in the first horizontal run of the plenum where it will not pick up radiant heat from the heat exchanger.
- 2 - Set thermostat for heat call. Unit must operate on second- stage heat. *If using a single-stage thermostat furnace must fire at least 10 minutes before switching to second-stage heat.*
- 3 - After plenum thermometers have reached their highest and steadiest readings, subtract the two readings. The difference should be in the range listed on the unit rating plate. If the temperature is too low, decrease blower speed. If temperature is too high, first check the firing rate. Provided the firing rate is acceptable, increase blower speed to reduce temperature.

### C-External Static Pressure

- 1 - Tap locations shown in FIGURE 53.
- 2 - Punch a 1/4" diameter hole in supply and return air plenums. Insert manometer hose flush with inside edge of hole or insulation. Seal around the hose with permagum. Connect the zero end of the manometer to the discharge (supply) side of the system. On ducted systems, connect the other end of manometer to the return duct as above.
- 3 - With only the blower motor running and the evaporator coil dry, observe the manometer reading. Adjust blower motor speed to deliver the air desired according to the job requirements.
- 4 - External static pressure drop must not be more than 0.8" W.C. in the heating mode and must not exceed 1.0" W.C in the cooling mode.
- 5 - Seal the hole when the check is complete.

### D-Discharge Air Temperature Sensor (DATS)

Units may have a discharge air temperature sensor located in the supply duct only. If the sensor is not in the supply duct then it must be removed and relocated.

Two types sensor are used (FIGURE 54 or FIGURE 55). If the sensor is suspect, check the location using FIGURE 54, FIGURE 56, FIGURE 57 and FIGURE 58 with tables TABLE 34, TABLE 36 and TABLE 38. Or check the location using FIGURE 55, FIGURE 56, FIGURE 57 and FIGURE 58 with TABLE 35, TABLE 37 and TABLE 39. FIGURE 59 shows field wiring for both types sensor to the furnace control. If the location and wiring are correct but the sensor is not working properly replace the sensor. Follow the DATS instructions found in the kit.

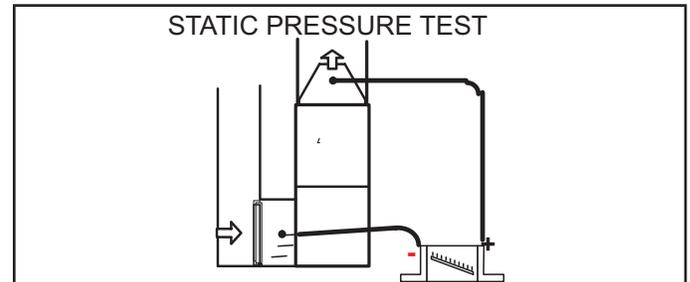

FIGURE 53

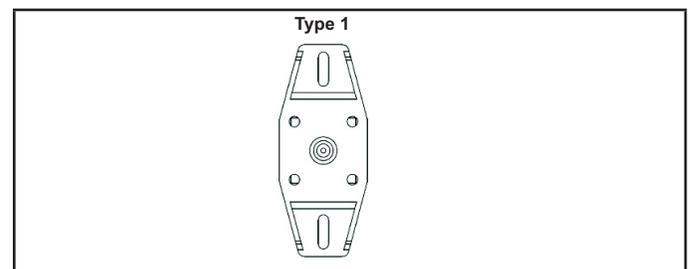

FIGURE 54

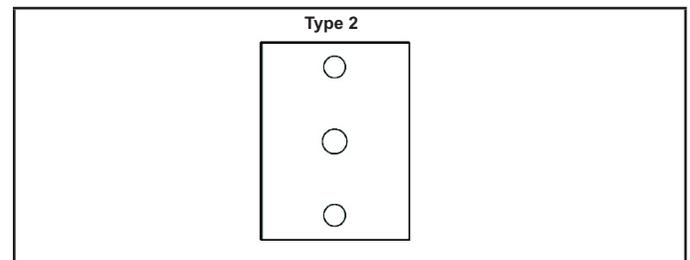

FIGURE 55

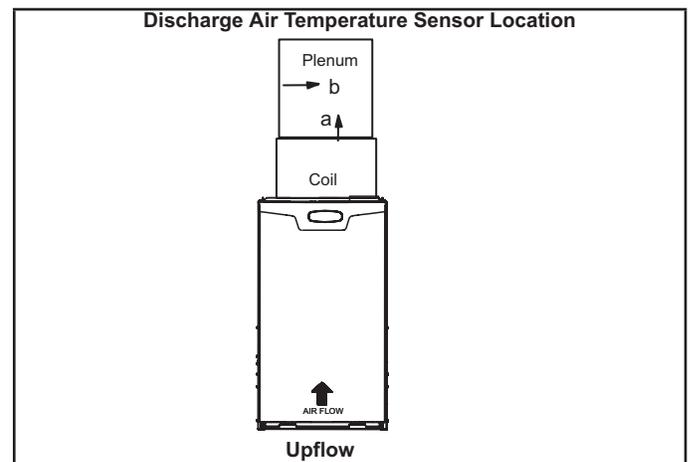

FIGURE 56

**TABLE 34**  
**Sensor Type 1 Upflow**

Unit	"a"	"b"
070V36B	6"	center
090V36C	12"	center
090V48C	1"	2" from left
090V60C	3"	2-1/2" from left
110V60C	3"	2" from left
135V60D	1"	4" from left

**TABLE 35**  
**Sensor Type 2 Upflow**

Unit	"a"	"b"
070V36B	2"	center
090V36C	3"	center
090V48C	2"	7" from right
090V60C	3"	4" from right
110V60C	2"	8" from right
135V60D	2"	7" from right

**Discharge Air Temperature Sensor Location**

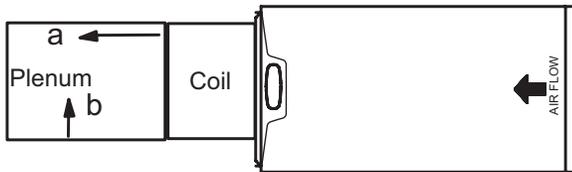

**Horizontal Left**

**FIGURE 57**

**TABLE 36**  
**Sensor Type 1 Horizontal Left**

Unit	"a"	"b"
070V36B	19"	center
090V36C	19"	center
090V48C	3"	2" from bottom
090V60C	1"	2" from bottom
110V60C	3"	2" from bottom
135V60D	1"	5" from bottom

**TABLE 37**  
**Sensor Type 2 Horizontal Left**

Unit	"a"	"b"
070V36B	19"	center
090V36C	19"	center
090V48C	3"	2" from bottom
090V60C	1"	2" from bottom
110V60C	3"	2" from bottom
135V60D	1"	5" from bottom

**Discharge Air Temperature Sensor Location**

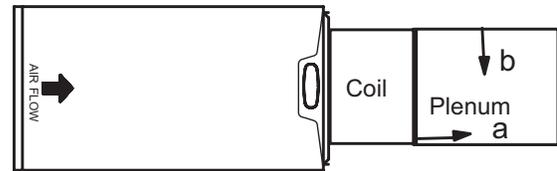

**Horizontal Right**

**FIGURE 58**

**TABLE 38**  
**Sensor Type 1 Horizontal Right**

Unit	"a"	"b"
070V36B	15"	center
090V36C	19"	center
090V48C	3"	2" from top
090V60C	1"	2" from top
110V60C	3"	2" from top
135V60D	1"	5" from top

**TABLE 39**

**Sensor Type 2 Horizontal Right**

Unit	"a"	"b"
070V36B	5"	center
090V36C	2"	8" from bottom
090V48C	3"	center
090V60C	3"	7" from top
110V60C	3"	center
135V60D	2"	7" from top

**Discharge Air Temperature Sensor Wiring**

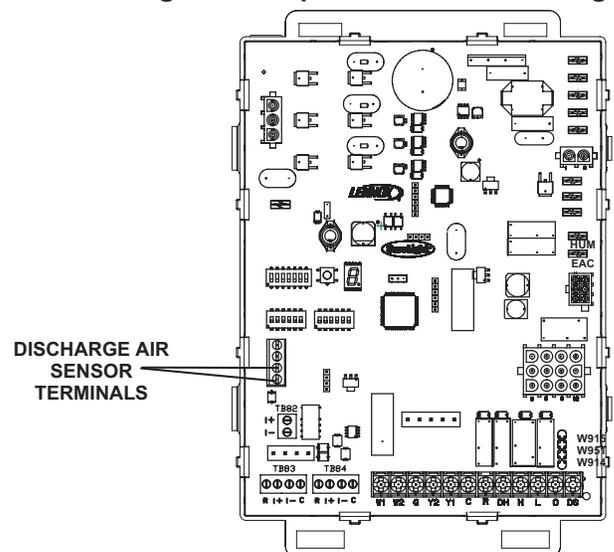

**FIGURE 59**

VII-MAINTENANCE

TABLE 40

**⚠ WARNING**  
**ELECTRICAL SHOCK, FIRE, OR EXPLOSION HAZARD.**  
 Failure to follow safety warnings exactly could result in dangerous operation, serious injury, death or property damage.  
 Improper servicing could result in dangerous operation, serious injury, death, or property damage. Before servicing, disconnect all electrical power to furnace.  
 When servicing controls, label all wires prior to disconnecting. Take care to reconnect wires correctly. Verify proper operation after servicing.

At the beginning of each heating season, system should be checked as follows by a qualified service technician:

**Blower**

Check the blower wheel for debris and clean if necessary. The blower motors are prelubricated for extended bearing life. No further lubrication is needed.

**⚠ WARNING**  
 The blower access panel must be securely in place when the blower and burners are operating. Gas fumes, which could contain carbon monoxide, can be drawn into living space resulting in personal injury or death.

**Filters**

All SLP99UHV filters are installed external to the unit. Filters should be inspected monthly. Clean or replace the filters when necessary to ensure proper furnace operation. See TABLE 40 for filter sizes.

**⚠ IMPORTANT**  
 If a highefficiency filter is being installed as part of this system to ensure better indoor air quality, the filter must be properly sized. Highefficiency filters have a higher static pressure drop than standardefficiency glass/foam filters. If the pressure drop is too great, system capacity and performance may be reduced.  
 The pressure drop may also cause the limit to trip more frequently during the winter and the indoor coil to freeze in the summer, resulting in an increase in the number of service calls.  
 Before using any filter with this system, check the specifications provided by the filter manufacturer against the data given in the appropriate Lennox Product Specifications bulletin. Additional information is provided in Service and Application Note ACC002 (August 2000).

Furnace Cabinet Width	Filter Size	
	Side Return	Bottom Return
17-1/2"	16 X 25 X 1 (1)	16 X 25 X 1 (1)
21"	16 X 25 X 1 (1)	20 X 25 X 1 (1)
24-1/2"	16 X 25 X 1 (2)	24 X 25 X 1 (1)

**Exhaust and air intake pipes**

Check the exhaust and air intake pipes and all connections for tightness and to make sure there is no blockage.

**NOTE** - After any heavy snow, ice or frozen fog event the furnace vent pipes may become restricted. Always check the vent system and remove any snow or ice that may be obstructing the plastic intake or exhaust pipes.

**Electrical**

**⚠ WARNING**  
 Electric Shock Hazard. Can cause injury or death. Unit must be properly grounded in accordance with national and local codes.

**⚠ WARNING**  
 Fire Hazard. Use of aluminum wire with this product may result in a fire, causing property damage, severe injury or death. Use copper wire only with this product.

**⚠ CAUTION**  
 Failure to use properly sized wiring and circuit breaker may result in property damage. Size wiring and circuit breaker(s) per Product Specifications bulletin (EHB) and unit rating plate.

- 1 - Check all wiring for loose connections.
- 2 - Check for the correct voltage at the furnace (furnace operating).
- 3 - Check amp-draw on the blower motor.  
 Motor Nameplate \_\_\_\_\_ Actual \_\_\_\_\_

**Condensate Hose Screens (FIGURE 60)**

Check the condensate hose screens for blockage and clean if necessary.

- 1 - Turn off power to the unit.
- 2 - Remove hoses from cold end header box. Twist and pull screens to remove.
- 3 - Inspect screens and rinse with tap water if needed.
- 4 - Reinstall screens, reconnect hoses and turn on power to unit.

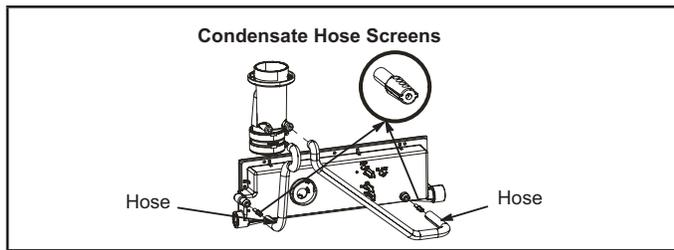

**FIGURE 60**

### Winterizing and Condensate Trap Care

- 1 - Turn off power to the unit.
- 2 - Have a shallow pan ready to empty condensate water.
- 3 - Remove the drain plug from the condensate trap and empty water. Inspect the trap then reinstall the drain plug and refill trap with water.

### Cleaning Heat Exchanger

If cleaning the heat exchanger becomes necessary, follow the below procedures and refer to FIGURE 1 when disassembling unit. Use papers or protective covering in front of furnace while removing heat exchanger assembly.

- 1 - Turn off electrical and gas supplies to the furnace.
  - 2 - Remove the furnace access panels.
  - 3 - Disconnect the 2-pin plug from the gas valve.
  - 4 - Remove gas supply line connected to gas valve. Remove the burner box cover and remove gas valve/ manifold assembly.
  - 5 - Remove sensor wire from sensor. Disconnect 2-pin plug from the ignitor.
  - 6 - Disconnect wires from flame roll-out switches.
  - 7 - Remove four burner box screws at the vestibule panel and remove burner box. Set burner box assembly aside.
- NOTE** - If necessary, clean burners at this time. Follow procedures outlined in Burner Cleaning section.
- 8 - Loosen the clamps to the flexible exhaust coupling.
  - 9 - Disconnect condensate drain line from the cold end header box.
  - 10 - Disconnect condensate drain tubing from flue collar. Remove screws that secures the flue collar into place. Remove flue collar. It may be necessary to cut the exiting exhaust pipe for removal of the fitting.
  - 11 - Mark and disconnect all combustion air pressure tubing from cold end header collector box.
  - 12 - Mark and remove wires from pressure switches. Remove pressure switches. Keep tubing attached to pressure switches.
  - 13 - Disconnect the 4-pin plug from the combustion air inducer. Remove two screws which secure combustion air inducer to collector box. Remove combustion air inducer assembly. Remove ground wire from vest panel.
  - 14 - Remove cold end header box.
  - 15 - Remove electrical junction box from the side of the furnace.

- 16 - Mark and disconnect any remaining wiring to heating compartment components. Disengage strain relief bushing and pull wiring and bushing through the hole in the blower deck.
- 17 - Remove the primary limit from the vestibule panel.
- 18 - Remove two screws from the front cabinet flange at the blower deck. Spread cabinet sides slightly to allow clearance for removal of heat exchanger.
- 19 - Remove screws along vestibule sides and bottom which secure vestibule panel and heat exchanger assembly to cabinet. Remove two screws from blower rail which secure bottom heat exchanger flange. Remove heat exchanger from furnace cabinet.
- 20 - Back wash heat exchanger with soapy water solution or steam. If steam is used it must be below 275°F (135°C) .
- 21 - Thoroughly rinse and drain the heat exchanger. Soap solutions can be corrosive. Take care to rinse entire assembly.
- 22 - Reinstall heat exchanger into cabinet making sure that the clamshells of the heat exchanger assembly are resting in the support located at the rear of the cabinet. Remove the indoor blower to view this area through the blower opening.
- 23 - Re-secure the supporting screws along the vestibule sides and bottom to the cabinet.
- 24 - Reinstall cabinet screws on front flange at blower deck.
- 25 - Reinstall the primary limit on the vestibule panel.
- 26 - Route heating component wiring through hole in blower deck and reinsert strain relief bushing.
- 27 - Reinstall electrical junction box.
- 28 - 27 - Reinstall the cold end header box.
- 29 - Reinstall the combustion air inducer. Reconnect the 4-pin plug to the wire harness.
- 30 - Reinstall pressure switches and reconnect pressure switch wiring.
- 31 - Carefully connect combustion air pressure switch hosing from pressure switches to proper stubs on cold end header collector box.
- 32 - Reconnect condensate drain line to the cold end header box.
- 33 - Use securing screws to reinstall flue collar to the top cap on the furnace. Reconnect exhaust piping and exhaust drain tubing.
- 34 - Replace flexible exhaust adapter on combustion air inducer and flue collar. Secure using two existing hose clamps.
- 35 - Reinstall burner box assembly in vestibule area.
- 36 - Reconnect flame roll-out switch wires.
- 37 - Reconnect sensor wire and reconnect 2-pin plug from ignitor.
- 38 - Secure burner box assembly to vestibule panel using four existing screws. **Make sure burners line up in center of burner ports.**



- 39 - Reinstall gas valve manifold assembly. Reconnect gas supply line to gas valve.
- 40 - Reinstall burner box cover.
- 41 - Reconnect 2-pin plug to gas valve.
- 42 - Replace the blower compartment access panel.
- 43 - Refer to instruction on verifying gas and electrical connections when re-establishing supplies.
- 44 - Follow lighting instructions to light and operate furnace for 5 minutes to ensure that heat exchanger is clean and dry and that furnace is operating properly.
- 45 - Replace heating compartment access panel

**Cleaning the Burner Assembly**

- 1 - Turn off electrical and gas power supplies to furnace. Remove upper and lower furnace access panels.
- 2 - Disconnect the 2-pin plug from the gas valve.
- 3 - Remove the burner box cover.
- 4 - Disconnect the gas supply line from the gas valve. Remove gas valve/manifold assembly.
- 5 - Mark and disconnect sensor wire from the sensor. Disconnect 2-pin plug from the ignitor at the burner box.

- 6 - Remove four screws which secure burner box assembly to vest panel. Remove burner box from the unit.
- 7 - Use the soft brush attachment on a vacuum cleaner to gently clean the face of the burners. Visually inspect the inside of the burners and crossovers for any blockage caused by foreign matter. Remove any blockage.
- 8 - Reconnect the sensor wire and reconnect the 2-pin plug to the ignitor wiring harness.
- 9 - Reinstall the burner box assembly using the existing four screws. Make sure that the burners line up in the center of the burner ports.
- 10 - Reinstall the gas valve manifold assembly. Reconnect the gas supply line to the gas valve. Reinstall the burner box cover.
- 11 - Reconnect 2-pin plug to gas valve.
- 12 - Replace the blower compartment access panel.
- 13 - Refer to instruction on verifying gas and electrical connections when re-establishing supplies.
- 14 - Follow lighting instructions to light and operate furnace for 5 minutes to ensure that heat exchanger is clean and dry and that furnace is operating properly.
- 15 - Replace heating compartment access panel.

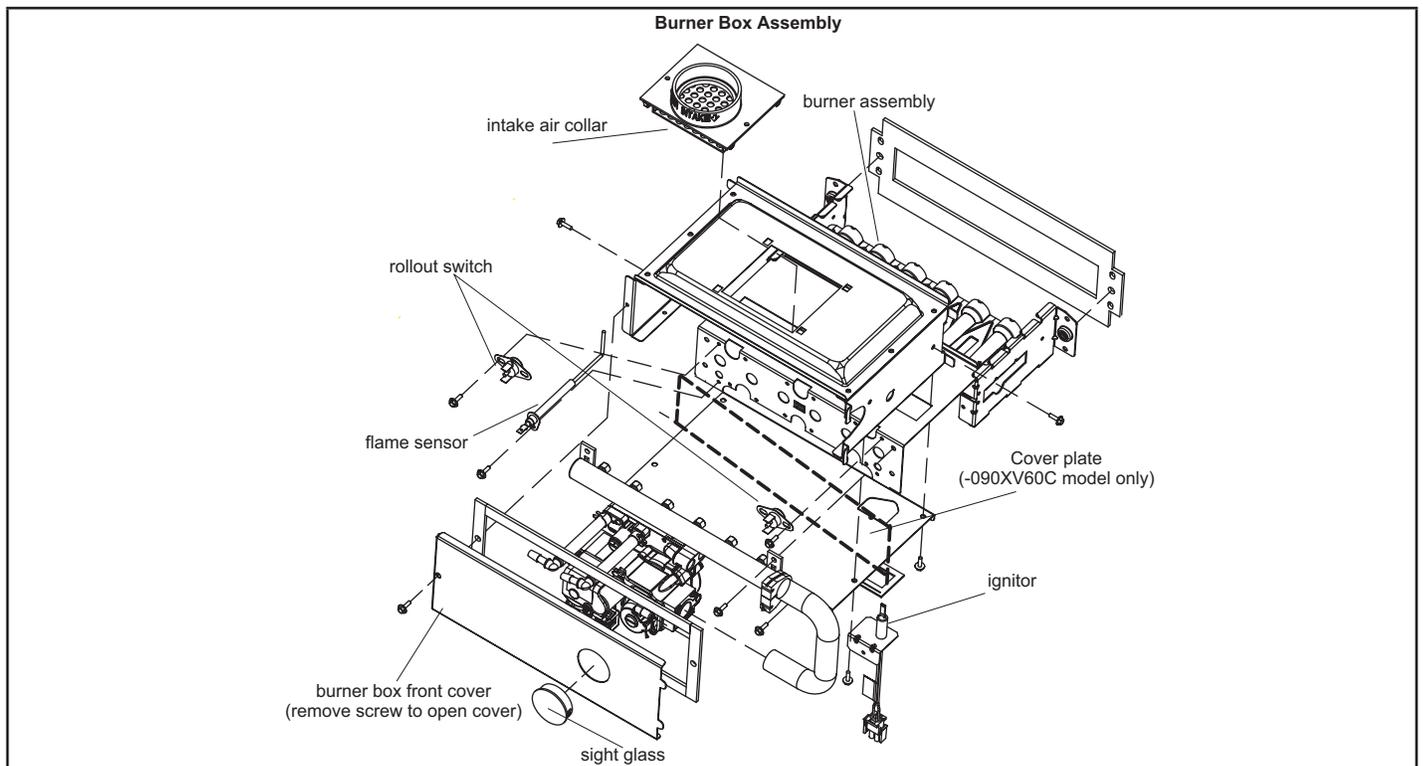

**FIGURE 61**

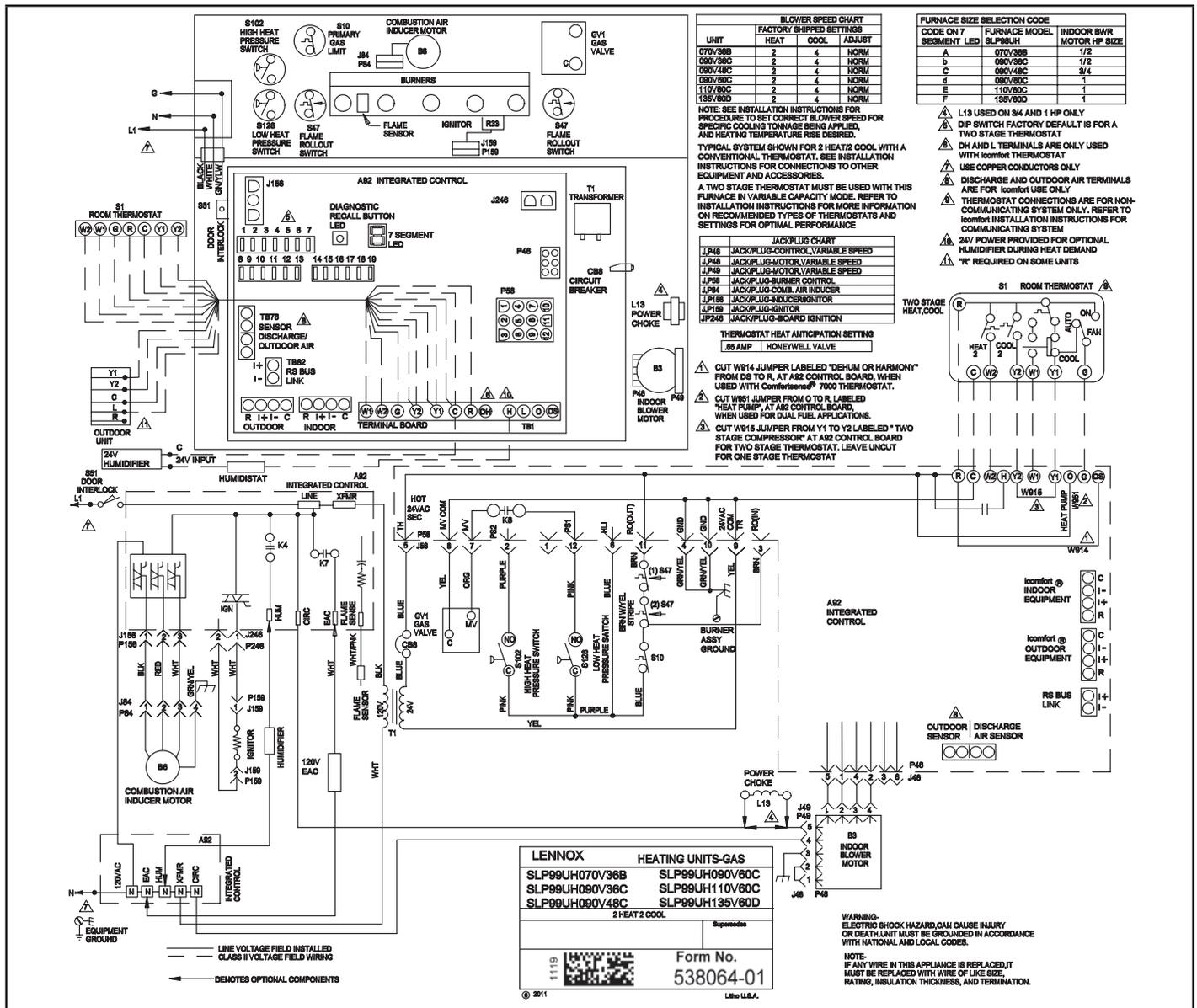

FIGURE 62

**NOTE** - The thermostat selection DIP switch on the control is factory-set in the "TWO-STAGE" position.

Applications Using a Two-Stage Thermostat

**A - Heating Sequence -- Control Thermostat Selection DIP switch in "Variable Capacity" Position**

- 1 - On a call for heat, thermostat first-stage contacts close sending a signal to the integrated control. The integrated control runs a self-diagnostic program and checks high temperature limit switches for normally closed contacts and pressure switches for normally open contacts. The combustion air inducer is energized at ignition speed, which is approximately the same as the inducer speed at 70 percent firing rate.
- 2 - Once the control receives a signal that the low-fire pressure switch has closed, the combustion air inducer begins a 15-second pre-purge in ignition speed.

- 3 - After the pre-purge is complete, a 20-second initial ignitor warm-up period begins. The combustion air inducer continues to operate at the ignition speed.
- 4 - After the 20-second warm-up period has ended, the gas valve is energized and ignition occurs. At the same time, the control module begins an indoor blower 45-second ON-delay. When the delay ends, the indoor blower motor is energized at a speed that matches the firing rate. After the 10-second ignition stabilization delay expires, the inducer speed is adjusted to the appropriate target rate. If the furnace is operating in the initial heating cycle after power-up, the initial firing rate will be approximately 35 percent. The firing rate on subsequent cycles will be automatically adjusted by the integrated control based on thermostat cycles. The firing rate will vary and will range from 40 percent to 90 percent. The furnace will continue this operation as long as the thermostat has a first-stage heating demand.

- 5 - If second-stage heat is required, the thermostat second-stage heat contacts close and send a signal to the integrated control. The integrated control either increases the firing rate to 70 percent (if the current rate is at or below 60 percent) or increases the firing rate by 10 percent (if the current rate is above 60 percent). If the call for heat continues 5 minutes beyond this initial upstage, the rate will be increased by 10 percent every 5 minutes until the call for heat is satisfied or the furnace reaches 100 percent rate. As the firing rate increases, the indoor blower motor is adjusted to a speed which is appropriate for the target rate.
- 6 - If second-stage heat demand is satisfied, but first stage is still present, the furnace will continue to operate at the present firing rate until the heat cycle ends.
- 7 - When the demand for first- and second-stage heat is satisfied, the gas valve is de-energized and the fieldselected indoor blower off delay begins. The combustion air inducer begins a 20-second post-purge period.
- 8 - When the combustion air post-purge period is complete, the inducer is de-energized. The indoor blower is de-energized at the end of the off delay.
- 6 - If the heating demand continues beyond the thirdstage on delay, the integrated control energizes the inducer at high speed. The indoor blower motor is adjusted to a speed which is appropriate for the target rate.
- 7 - When the thermostat heating demand is satisfied, the gas valve is de-energized and the combustion air inducer begins a 20-second post-purge. The field-selected indoor blower off delay begins.
- 8 - When the combustion air post-purge period is complete, the inducer is de-energized. The indoor blower is de-energized at the end of the off delay.

#### **Applications Using A Single-Stage Thermostat**

##### **B - Heating Sequence -- Control Thermostat Selection DIP switch in "Single-Stage" Position**

- 1 - On a call for heat, thermostat first-stage contacts close sending a signal to the integrated control. The integrated control runs a self-diagnostic program and checks high temperature limit switches for normally closed contacts and pressure switches for normally open contacts. The combustion air inducer is energized at the ignition speed, which is approximately the same as the inducer speed at 70 percent firing rate.
- 2 - Once the control receives a signal that the low-fire pressure switch has closed, the combustion air inducer begins a 15-second pre-purge at the ignition speed.
- 3 - After the pre-purge is complete, a 20-second initial ignitor warm-up period begins. The combustion air inducer continues to operate at the ignition speed.
- 4 - After the 20-second warm-up period has ended, the gas valve is energized and ignition occurs, which initiates a 10-second ignition stabilization delay. At the same time, the control module sends a signal to begin an indoor blower 45-second ON-delay. When the delay ends, the indoor blower motor is energized at a speed which is appropriate for the firing rate. After the 10-second ignition stabilization delay expires, the inducer speed is adjusted to 40 percent speed. The integrated control also initiates a second-stage on delay (factory-set at 7 minutes; adjustable to 12 minutes).
- 5 - If the heating demand continues beyond the secondstage on delay, the integrated control energizes the combustion air inducer at 70 percent speed. The indoor lower motor is adjusted to a speed which matches the target rate. A fixed, 10-minute third-stage on delay is initiated.

#### **Applications Using a Two-Stage Thermostat**

##### **C - Heating Sequence -- Control Thermostat Selection DIP switch in "Two-Stage" Position (Factory Setting)**

- 1 - On a call for heat, thermostat first-stage contacts close sending a signal to the integrated control. The integrated control runs a self-diagnostic program and checks high temperature limit switches for normally closed contacts and pressure switches for normally open contacts. The combustion air inducer is energized at ignition speed, which is approximately the same as the inducer speed at 70 percent firing rate.
- 2 - Once the control receives a signal that the low-fire pressure switch has closed, the combustion air inducer begins a 15-second pre-purge at the ignition speed.
- 3 - After the pre-purge is complete, a 20-second initial ignitor warm-up period begins. The combustion air inducer continues to operate at the ignition speed.
- 4 - After the 20-second warm-up period has ended, the gas valve is energized and ignition occurs. At the same time, the control module sends a signal to begin an indoor blower 45-second ON-delay. When the delay ends, the indoor blower motor is energized at a speed that matches the firing rate. After the 10-second ignition stabilization delay expires, the inducer speed is adjusted to the appropriate target rate. The inducer will remain at the 70 percent speed as long as the thermostat has a first-stage heating demand.
- 5 - If second-stage heat is required, the thermostat second-stage heat contacts close and send a signal to the integrated control. The integrated control initiates a 30-second second-stage recognition delay.
- 6 - At the end of the recognition delay and on all subsequent calls for heat in the same heating cycle, the integrated control energizes the combustion air inducer at high speed. The control also checks the high-fire pressure switch to make sure it is closed. As the inducer speed is increased to high, the indoor blower motor is adjusted to a speed which is appropriate for the target rate.
- 7 - When the demand for high-fire (second stage) heat is satisfied, the gas valve is de-energized and the fieldselected indoor blower off delay begins. The combustion air inducer begins a 20-second post-purge period.
- 8 - When the combustion air post-purge period is complete, the inducer is de-energized. The indoor blower is de-energized at the end of the off delay.

# A - Sequence of Operation and Troubleshooting Flow Chart

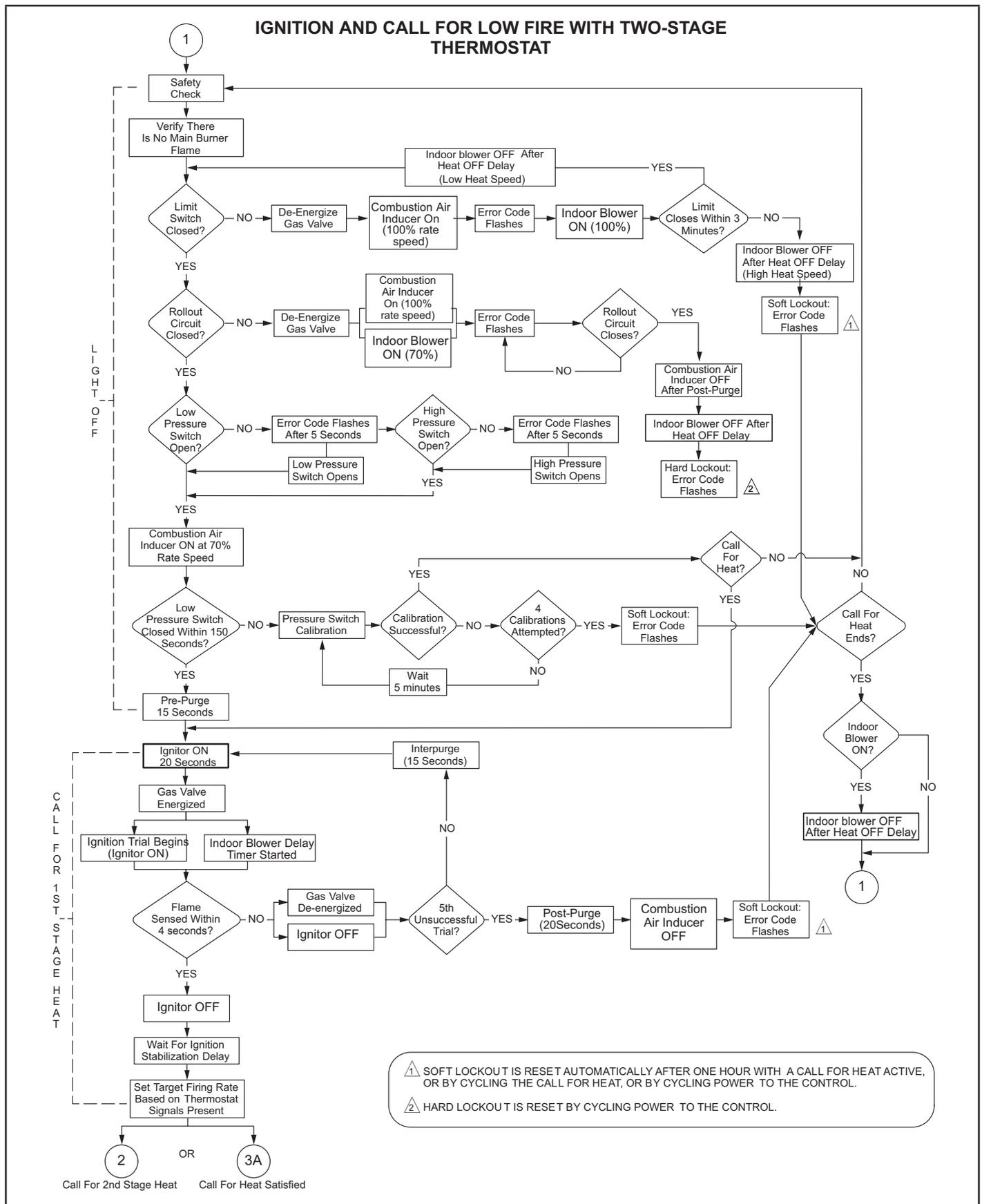

## CALL FOR HIGH FIRE WITH TWO-STAGE THERMOSTAT

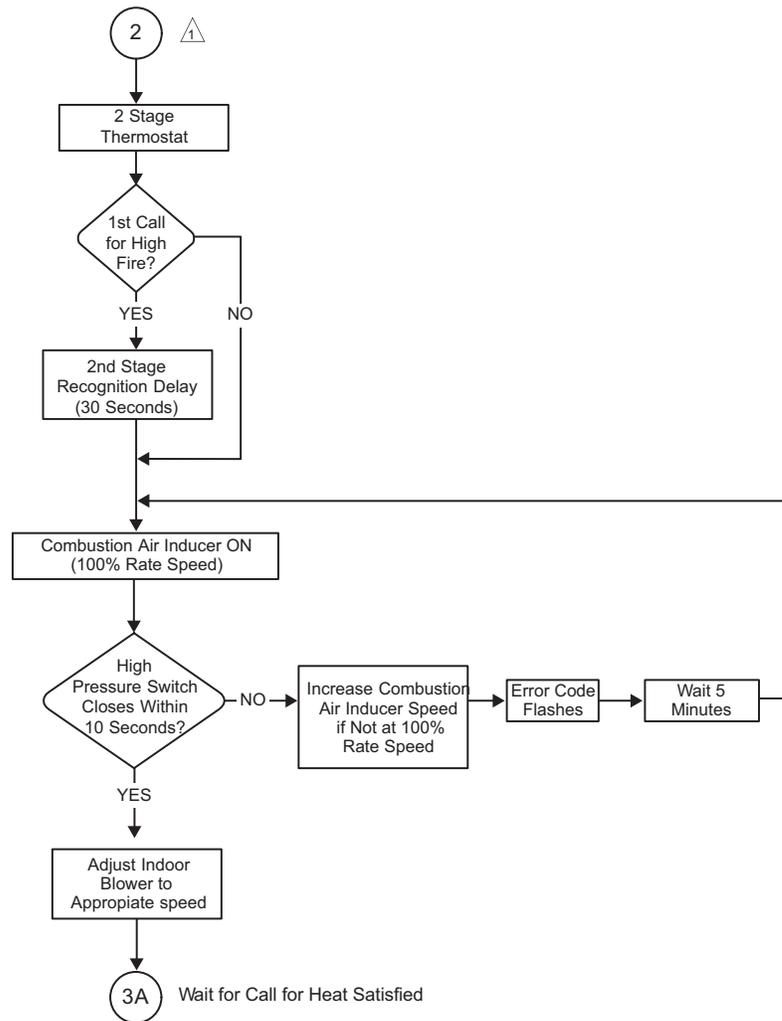

⚠️ System will always light at 70% even if 2nd stage call for heat is in place

⚠️ If the high pressure switch does not close within 5 attempts, the system will operate at low fire for the remainder of the call for heat at request

# CALL FOR HEAT SATISFIED

RUN MODE (2 STAGE THERMOSTAT)  
 1ST OR 2ND STAGE CALL FOR HEAT ALL  
 INPUTS MONITORED (LIMIT, PRESSURE,  
 CALL FOR HEAT / COOL, FLAME LEVEL)

RUN MODE (SINGLE STAGE THERMOSTAT)  
 ALL INPUTS MONITORED (LIMIT, PRESSURE,  
 CALL FOR HEAT / COOL, FLAME LEVEL)

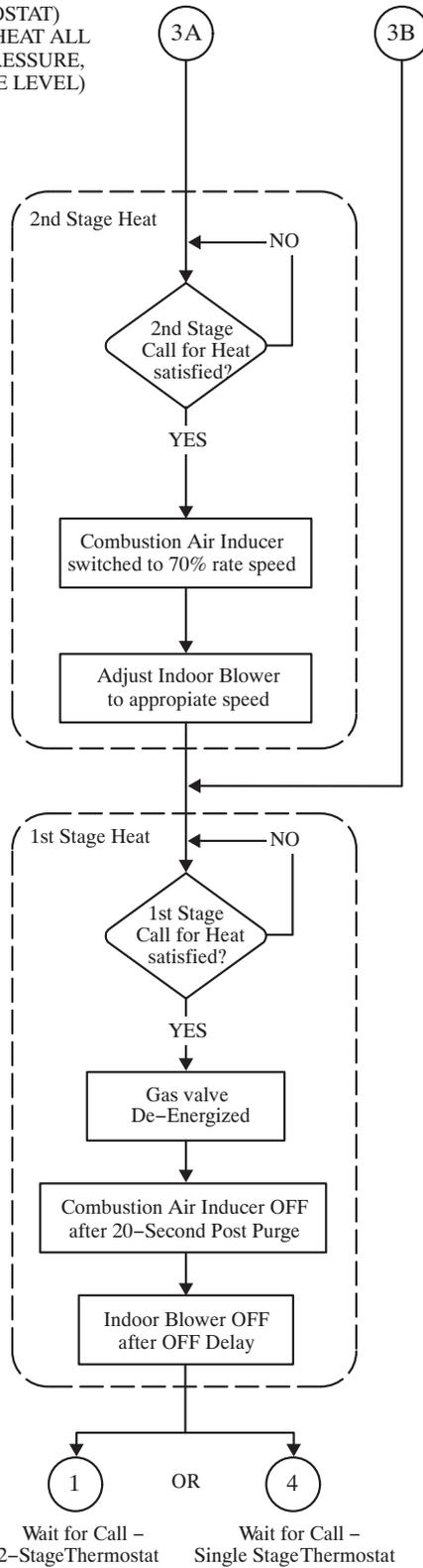

# IGNITION AND CALL FOR HEAT WITH SINGLE-STAGE THERMOSTAT

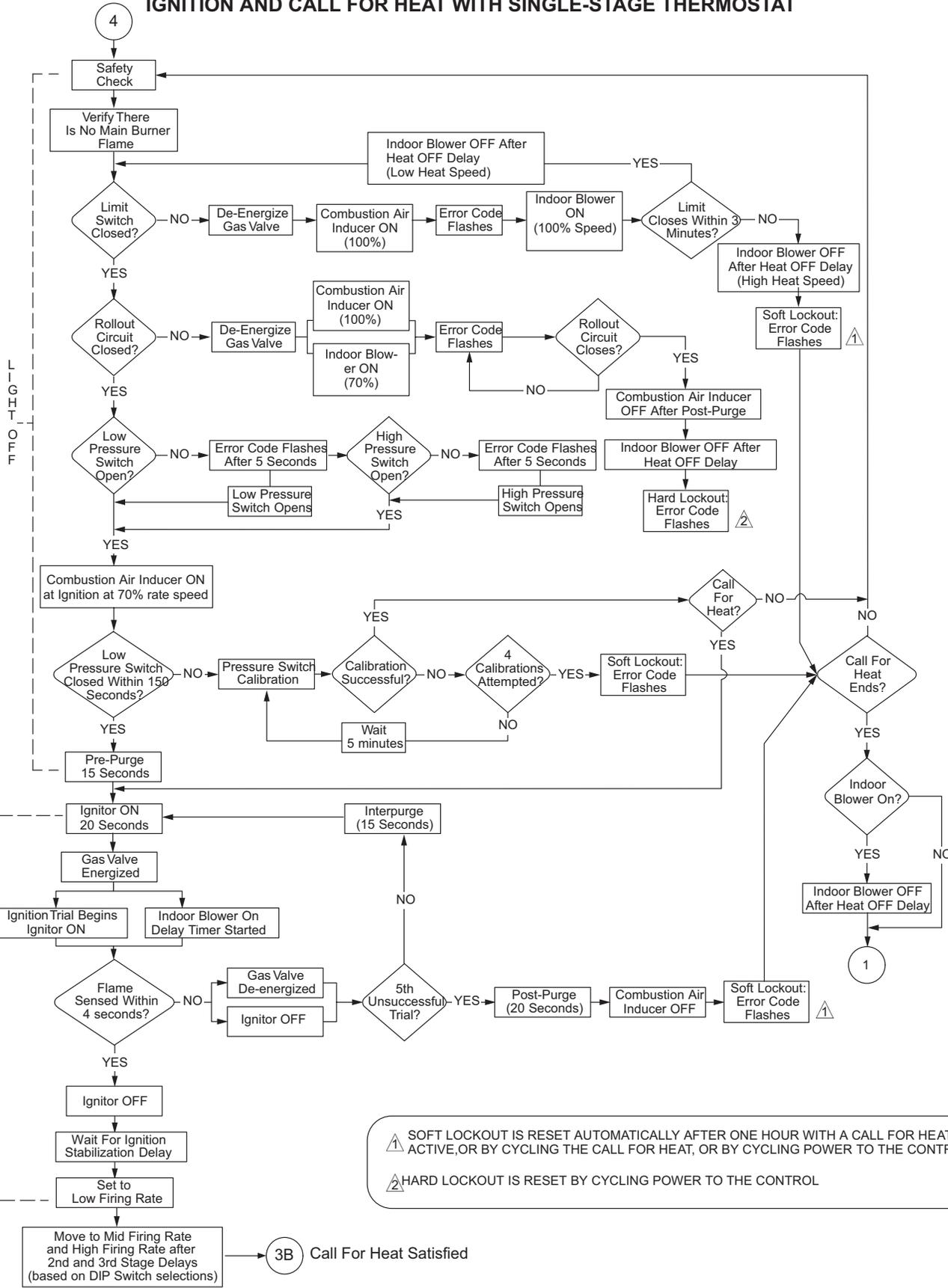

⚠️ SOFT LOCKOUT IS RESET AUTOMATICALLY AFTER ONE HOUR WITH A CALL FOR HEAT ACTIVE, OR BY CYCLING THE CALL FOR HEAT, OR BY CYCLING POWER TO THE CONTROL.

⚠️ HARD LOCKOUT IS RESET BY CYCLING POWER TO THE CONTROL.

## CALL FOR COOLING

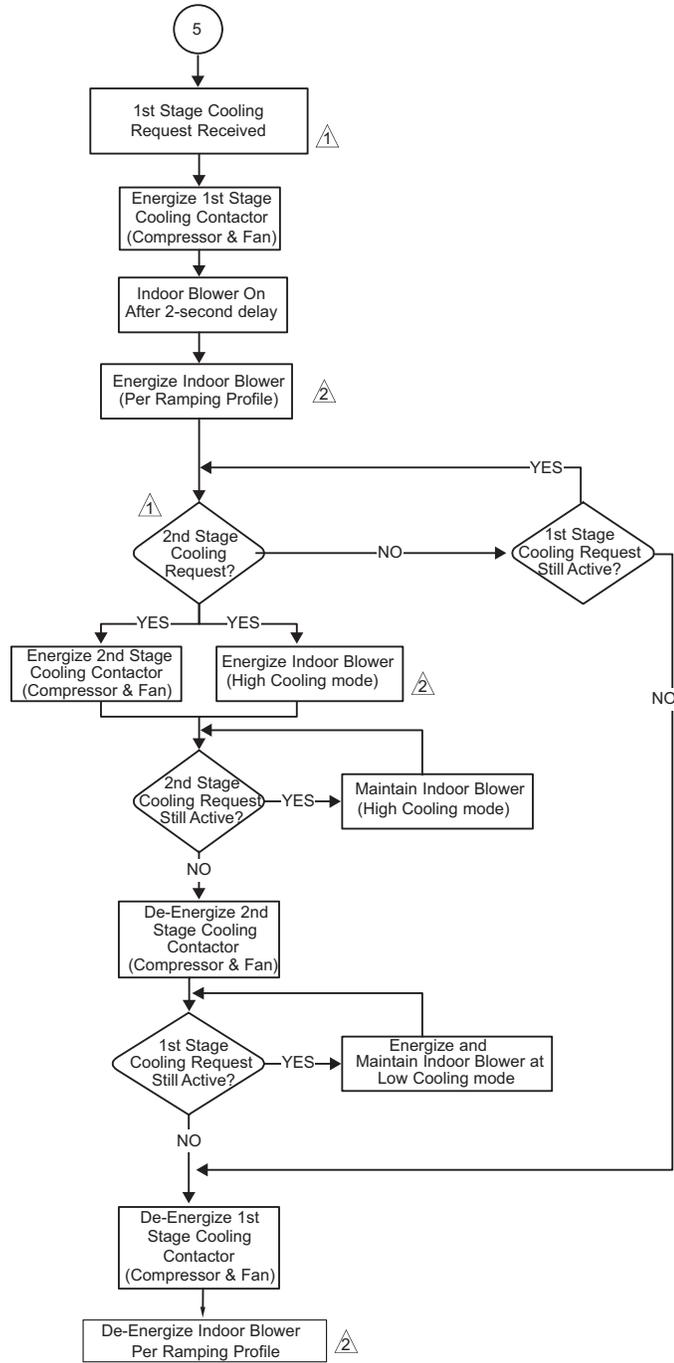

⚠ 2nd stage cooling operation requires a 2-stage thermostat, a 2-stage cooling system and on-board link W915 must be cut. The control will not respond to a 2nd stage cooling request unless a 1st stage cooling request is active

⚠ Indoor blower cooling mode and high cooling mode have a specific ON, OFF and speed ramping profiles. The specific profile is selected using the DIP switches on the control.



## CONTINUOUS LOW SPEED INDOOR BLOWER SEQUENCE OF OPERATION

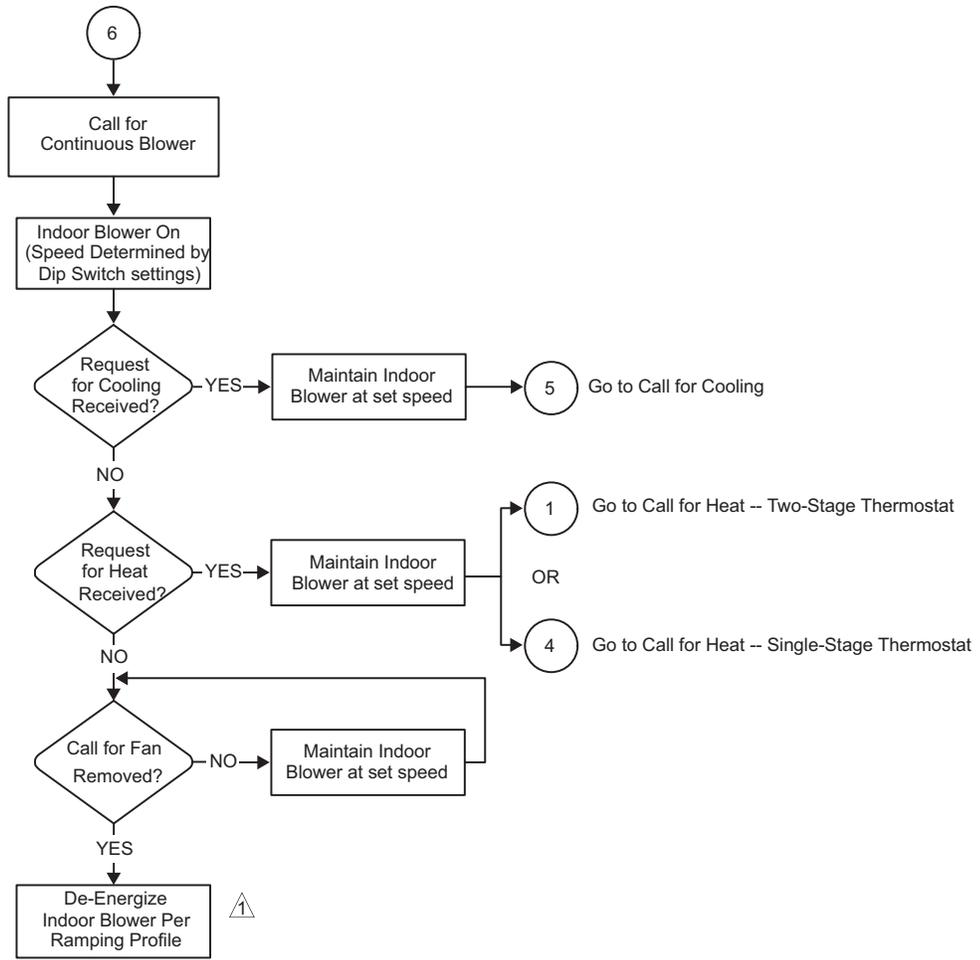

⚠ Indoor blower low cooling mode and high cooling mode, have specific ON - OFF and speed ramping profiles. The specific profile is selected using the dip switches on the control.

## IX- Field Wiring For Non-Communicating Thermostats

Thermostat	DIP Switch Settings and On-Board Links			W951 (O to R) Heat Pumps	Wiring Connections
	DIP Switch 1	W915 (Y1 to Y2) Two-Stage Cooling	W914 (DS to R) Dehumidifi- cation or Harmony III™		
1Heat / 1 Cool <i>NOTE - Use DIP switch 3 to set second-stage heat ON delay. OFF-7 minutes. ON-12 minutes.</i>	ON	Intact	Intact	Intact	
1 Heat / 2 Cool <i>NOTE - Use DIP switch 3 to set second-stage heat ON delay. OFF-7 minutes. ON-12 minutes.</i>	ON	Cut	Intact	Intact	
1 Heat / 2 Cool with t'stat with dehumidification mode <i>NOTE - Use DIP switch 3 to set second-stage heat ON delay. OFF-7 minutes. ON-12 minutes.</i>	ON	Cut	Cut	Intact	

\* "R" required on some units.

Field Wiring Continued

Thermostat	DIP Switch Settings and On-Board Links				Wiring Connections																														
	DIP Switch 1	W915 (Y1 to Y2) Two-Stage Cooling	W914 (DS to R) Dehumidifi- cation or Harmony III™	W951 (O to R) Heat Pumps																															
2 Heat / 2 Cool	OFF	Cut	Intact	Intact	<table border="0"> <tr> <td>S1 T'STAT</td> <td>CONTROL TERM. STRIP</td> <td>OUTDOOR UNIT</td> </tr> <tr> <td></td> <td>(DS)</td> <td></td> </tr> <tr> <td>(W2)-----</td> <td>(W2)</td> <td></td> </tr> <tr> <td>(W1)-----</td> <td>(W1)</td> <td></td> </tr> <tr> <td>(R)-----</td> <td>(R)</td> <td>-----*</td> </tr> <tr> <td>(G)-----</td> <td>(G)</td> <td></td> </tr> <tr> <td>(C)-----</td> <td>(C)</td> <td>-----</td> </tr> <tr> <td>(Y2)-----</td> <td>(Y2)</td> <td>-----</td> </tr> <tr> <td>(Y1)-----</td> <td>(Y1)</td> <td>-----</td> </tr> <tr> <td></td> <td>(O)</td> <td></td> </tr> </table>	S1 T'STAT	CONTROL TERM. STRIP	OUTDOOR UNIT		(DS)		(W2)-----	(W2)		(W1)-----	(W1)		(R)-----	(R)	-----*	(G)-----	(G)		(C)-----	(C)	-----	(Y2)-----	(Y2)	-----	(Y1)-----	(Y1)	-----		(O)	
S1 T'STAT	CONTROL TERM. STRIP	OUTDOOR UNIT																																	
	(DS)																																		
(W2)-----	(W2)																																		
(W1)-----	(W1)																																		
(R)-----	(R)	-----*																																	
(G)-----	(G)																																		
(C)-----	(C)	-----																																	
(Y2)-----	(Y2)	-----																																	
(Y1)-----	(Y1)	-----																																	
	(O)																																		
2 Heat / 2 Cool with t'stat with dehumidifica- tion mode	OFF	Cut	Cut	Intact	<table border="0"> <tr> <td>S1 T'STAT</td> <td>CONTROL TERM. STRIP</td> <td>OUTDOOR UNIT</td> </tr> <tr> <td>(D)-----</td> <td>(DS)</td> <td></td> </tr> <tr> <td>(W2)-----</td> <td>(W2)</td> <td></td> </tr> <tr> <td>(W1)-----</td> <td>(W1)</td> <td></td> </tr> <tr> <td>(R)-----</td> <td>(R)</td> <td>-----*</td> </tr> <tr> <td>(G)-----</td> <td>(G)</td> <td></td> </tr> <tr> <td>(C)-----</td> <td>(C)</td> <td>-----</td> </tr> <tr> <td>(Y2)-----</td> <td>(Y2)</td> <td>-----</td> </tr> <tr> <td>(Y1)-----</td> <td>(Y1)</td> <td>-----</td> </tr> </table>	S1 T'STAT	CONTROL TERM. STRIP	OUTDOOR UNIT	(D)-----	(DS)		(W2)-----	(W2)		(W1)-----	(W1)		(R)-----	(R)	-----*	(G)-----	(G)		(C)-----	(C)	-----	(Y2)-----	(Y2)	-----	(Y1)-----	(Y1)	-----			
S1 T'STAT	CONTROL TERM. STRIP	OUTDOOR UNIT																																	
(D)-----	(DS)																																		
(W2)-----	(W2)																																		
(W1)-----	(W1)																																		
(R)-----	(R)	-----*																																	
(G)-----	(G)																																		
(C)-----	(C)	-----																																	
(Y2)-----	(Y2)	-----																																	
(Y1)-----	(Y1)	-----																																	
2 Heat / 1 Cool	OFF	Intact	Intact	Intact	<table border="0"> <tr> <td>S1 T'STAT</td> <td>CONTROL TERM. STRIP</td> <td>OUTDOOR UNIT</td> </tr> <tr> <td></td> <td>(DS)</td> <td></td> </tr> <tr> <td>(W2)-----</td> <td>(W2)</td> <td></td> </tr> <tr> <td>(W1)-----</td> <td>(W1)</td> <td></td> </tr> <tr> <td>(R)-----</td> <td>(R)</td> <td>-----*</td> </tr> <tr> <td>(G)-----</td> <td>(G)</td> <td></td> </tr> <tr> <td>(C)-----</td> <td>(C)</td> <td>-----</td> </tr> <tr> <td></td> <td>(Y2)</td> <td></td> </tr> <tr> <td>(Y)-----</td> <td>(Y1)</td> <td>-----</td> </tr> <tr> <td></td> <td>(O)</td> <td></td> </tr> </table>	S1 T'STAT	CONTROL TERM. STRIP	OUTDOOR UNIT		(DS)		(W2)-----	(W2)		(W1)-----	(W1)		(R)-----	(R)	-----*	(G)-----	(G)		(C)-----	(C)	-----		(Y2)		(Y)-----	(Y1)	-----		(O)	
S1 T'STAT	CONTROL TERM. STRIP	OUTDOOR UNIT																																	
	(DS)																																		
(W2)-----	(W2)																																		
(W1)-----	(W1)																																		
(R)-----	(R)	-----*																																	
(G)-----	(G)																																		
(C)-----	(C)	-----																																	
	(Y2)																																		
(Y)-----	(Y1)	-----																																	
	(O)																																		

\* "R" required on some units.

Field Wiring Continued

Thermostat	DIP Switch Settings and On-Board Links			Wiring Connections	
	DIP Switch	W915 (Y1 to Y2) Two-Stage Cooling	W914 (DS to R) Dehumidifi- cation or Harmony III™		W951 (O to R) Heat Pumps
Dual Fuel Single-Stage Heat Pump  ComfortSense® 7000 L7742U thermostat w/ dual fuel capa- bilities Capable of 2-stage gas heat control	DIP Switch 1 OFF	Intact	Intact	Cut	
Dual Fuel Two Stage Heat Pump  ComfortSense® 7000 L7742U thermostat w/ dual fuel capa- bilities Capable of 2-stage gas heat control	DIP Switch 1 OFF	Cut	Intact	Cut	

\* Connect W1 to W1 ONLY if using defrost tempering kit 67M41.

NOTE - **Do NOT** make a wire connection between the room thermostat L terminal and the L terminal of the integrated control.