

KGB024 through 090

The KGB packaged gas units are available in standard cooling efficiency (024, 030, 036, 048 060, 072, 074 and 090). Cooling capacities range from 2 to 7-1/2 tons (7 to 26kW).

KGB024, 030, 036, 048, 060, 072, 074 units are available in 65,000 BTUH heat capacity /KGB036, 048, 060, 072, 074 and 090 units are available in 108,000 BTUH (105,000 BTUH in earlier built units) heat capacity. KGB048, 060, 072, 074 and 090 units are available in 150,000 BTUH (44 kW) heat sizes. Two stage heat is available in units with 108,000 (105,000 in earlier built units) and 150,000 BTUH capacities. Gas heat sections are designed with aluminized steel tube heat exchangers.

Information contained in this manual is intended for use by qualified service technicians only. All specifications are subject to change. Procedures outlined in this manual are presented as a recommendation only and do not supersede or replace local or state codes.

If the unit must be lifted for service, rig unit by attaching four cables to the holes located in the unit base rail (two holes at each corner). Refer to the installation instructions for the proper rigging technique.

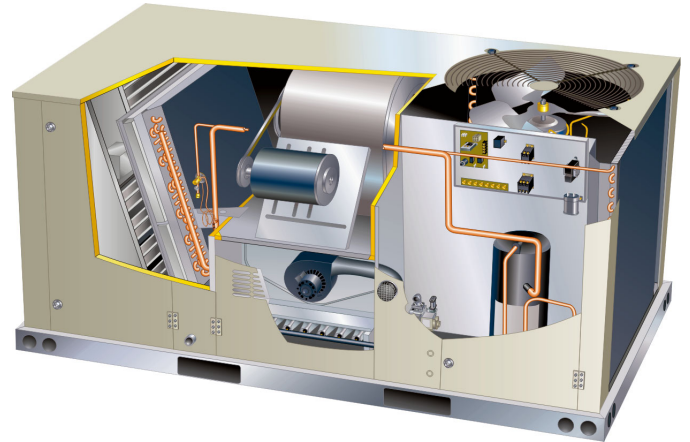

ELECTROSTATIC DISCHARGE (ESD) Precautions and Procedures

⚠ CAUTION

Electrostatic discharge can affect electronic components. Take precautions during unit installation and service to protect the unit's electronic controls. Precautions will help to avoid control exposure to electrostatic discharge by putting the furnace, the control and the technician at the same electrostatic potential. Neutralize electrostatic charge by touching hand and all tools on an unpainted unit surface, such as the gas valve or blower deck, before performing any service procedure.

⚠ WARNING

Improper installation, adjustment, alteration, service or maintenance can cause property damage, personal injury or loss of life. Installation and service must be performed by a licensed professional installer (or equivalent), service agency or the gas supplier.

⚠ WARNING



Electric shock hazard. Can cause injury or death. Before attempting to perform any service or maintenance, turn the electrical power to unit OFF at disconnect switch(es). Unit may have multiple power supplies.

⚠ CAUTION

As with any mechanical equipment, contact with sharp sheet metal edges can result in personal injury. Take care while handling this equipment and wear gloves and protective clothing.

Table of Contents

Options	Page 2
Specifications	Page 6
Spec. Gas Heat / High Altitude ...	Page 13
Blower Data	Page 14
Electrical Data	Page 31
I Unit Components	Page 35
II Placement and Installation	Page 48
III Start Up Operation	Page 48
IV Charging	Page 50
V System Service Checks	Page 60
VI Maintenance	Page 62
VII Accessories	Page 63
VIII Diagrams	Page 69

OPTIONS / ACCESSORIES

Item	Model No.	Catalog No.	Unit Model No.							
			KGB 024	KGB 030	KGB 036	KGB 048	KGB 060	KGB 072	KGB 074	KGB 090
COOLING SYSTEM										
Condensate Drain Trap	PVC - C1TRAP20AD2	76W26	X	X	X	X	X	X	X	X
	Copper - C1TRAP10AD2	76W27	X	X	X	X	X	X	X	X
Conventional Fin/Tube Condenser Coil (replaces Environ™ Coil System)		Factory	O	O	O	O	O		¹ O	O
Drain Pan Overflow Switch	K1SNSR71AB1-	74W42	X	X	X	X	X	X	X	X
Low Ambient Kit	K1SNSR33AN2	14D89	X	X	X	X	X	X	X	X
Efficiency	High								O	O
	Standard		O	O	O	O	O			O
Refrigerant Type	R-410A		O	O	O	O	O	O	O	O
HEATING SYSTEM										
Bottom Gas Piping Kit	T1GPKT01AN1	19W50	X	X	X	X	X	X	X	X
Low Temperature Vestibule Heater	208/230V-1 or 3 ph - T1CWKT01AN1Y	19W53	X	X	X	X	X	X	X	X
	460V-3ph - T1CWKT01AN1G	19W54			X	X	X	X	X	X
	575V-3ph - T1CWKT01AN1J	19W62			X	X	X	X	X	X
Combustion Air Intake Extensions	T1EXTN10AN1	19W51	X	X	X	X	X	X	X	X
Gas Heat Input	Standard One-Stage - 65 kBtuh input	Factory	O	O	O	O	³ O	O	O	
	Standard Two-Stage - 53/70 kBtuh input	Factory			² O	² O	O	² O	² O	
	Medium One-Stage - 108 kBtuh input	Factory			O	O	³ O	O	O	O
	Medium Two Stage - 81/108 kBtuh input	Factory			O	O	O	O	O	O
	High One-Stage - 150 kBtuh input	Factory					³ O	³ O	O	O
	High Two-Stage - 113/150 kBtuh input	Factory					³ O	O	O	O
LPG/Propane Conversion Kits	For one-stage models - C1PROP10AP3	14N20	X	X	X	X	X	X	X	X
	For two-stage models - C1PROP20AP3	14N21			X	X	X	X	X	X
Stainless Steel Heat Exchanger		Factory	O	O	O	O	O	O	O	O
Vertical Vent Extension	C1EXTN20FF1	31W62	X	X	X	X	X	X	X	X

¹ 074S models only.

² Standard Two-Stage Heat is only available with Low NOx Models.

³ Three-Phase models only.

NOTE - The catalog and model numbers that appear here are for ordering field installed accessories only.

OX - Field Installed or Configure to Order (Factory Installed)

O - Configure to Order (Factory Installed)

X - Field Installed

OPTIONS / ACCESSORIES

Item	Model No.	Catalog No.	Unit Model No.							
			KGB 024	KGB 030	KGB 036	KGB 048	KGB 060	KGB 072	KGB 074	KGB 090
BLOWER - SUPPLY AIR										
Motors	Direct Drive (ECM) - 0.33 hp (208/230V-1ph)	Factory	O	O						
	Direct Drive (ECM) - 0.50 hp (208/230V-1ph)	Factory			O					
	Direct Drive (ECM) - 0.75 hp (208/230V-1ph)	Factory				O				
	Direct Drive (ECM) - 1.0 hp (208/230V-1ph)	Factory					O			
	Direct Drive (PSC) - 0.5 hp (208/230V-3ph, 460V-3ph, 575V-3ph)	Factory			O	O				
	Direct Drive (PSC) - 0.75 hp (208/230V-3ph, 460V-3ph, 575V-3ph)	Factory					O			
	Belt Drive - 1 hp (208/230V, 460V, 575V-3ph) Standard Efficiency	Factory			O	O	O	O	³ O	⁴ O
	Belt Drive - 2 hp (208/230V, 460V, 575V-3ph) Standard Efficiency	Factory			O	O	O	O	³ O	⁴ O
	Belt Drive - 3 hp (208/230V, 460V, 575V-3ph) Standard Efficiency	Factory								⁴ O
	Belt Drive - 1 hp (208/230V, 460V, 575V-3ph) (2 Speed)	Factory							³ O	
Belt Drive - 2 hp (208/230V, 460V, 575V-3ph) (2 Speed)	Factory							³ O	⁵ O	
Drive Kits See Blower Data Tables for selection	Kit A01 - T1DRKT001-1 - 673-1010 rpm	Factory			O					
	Kit A02 - T1DRKT002-1 - 745-1117 rpm	Factory				O				
	Kit A03 - T1DRKT003-1 - 833-1250 rpm	Factory					O			
	Kit A04 - T1DRKT004-1 - 968-1340 rpm	Factory						O	¹ O	
	Kit A05 - T1DRKT005-1 - 897-1346 rpm	Factory			O					
	Kit A06 - T1DRKT006-1 - 1071-1429 rpm	Factory				O				
	Kit A07 - T1DRKT007-1 - 1212-1548 rpm	Factory					O			
	Kit A08 - T1DRKT008-1 - 1193-1591 rpm	Factory						O	¹ O	
	Kit AA01 - T1DRKT001AP1 - 522-784 rpm	Factory						O	² O	
	Kit AA02 - T1DRKT002AP1 - 632-875 rpm	Factory						O	² O	
Kit AA03 - T1DRKT003AP1 - 798-1105 rpm	Factory						O	² O		
Kit AA04 - T1DRKT004AP1 - 921-1128 rpm	Factory								⁶ O	

CABINET

Combination Coil/Hail Guards	C1GARD51A-1	13R98	X	X	X	X				
	C1GARD51AT1	13T03					X	X	X	
	K1GARD50AP1	13T17								X
Corrosion Protection		Factory	O	O	O	O	O	O	O	O
Hinged Access Panels			O	O	O	O	O	O	O	O

CONTROLS

NOTE - Also see Conventional Thermostat Control Systems on page <?> for Additional Options.

Smoke Detector - Supply or Return (Power board and one sensor)	C1SNSR44AP1	53W78	X	X	X	X	X	X	X	X
Smoke Detector - Supply and Return (Power board and two sensors)	C1SNSR43AP1	53W79	X	X	X	X	X	X	X	X
L Connection® Building Automation System		- - -	X	X	X	X	X	X	X	X

¹ 074S Belt Drive models only.

² 074H Belt Drive models only.

³ KGB074B models have an optional 1hp or 2hp **Single Speed** Belt Drive; KGB074T models have an optional 1hp or 2hp **Two Speed** Belt Drive

⁴ KGB090B models have an optional 1hp, 2hp or 3hp Single Speed Belt Drive

⁵ KGB090T models have 2hp Two Speed Belt Drive

⁶ KGB090B with 3 hp blower motor only.

NOTE - The catalog and model numbers that appear here are for ordering field installed accessories only.

OX - Field Installed or Configure to Order (Factory Installed)

O - Configure to Order (Factory Installed)

X - Field Installed

OPTIONS / ACCESSORIES

Item	Model No.	Catalog No.	Unit Model No.							
			KGB 024	KGB 030	KGB 036	KGB 048	KGB 060	KGB 072	KGB 074	KGB 090
ECONOMIZER										
Standard Economizer With Outdoor Air Hood (Sensible Control) (Not for Title 24)										
Standard Economizer - Includes Barometric Relief Dampers and Exhaust Hood	K1ECON30A-3-	14D90	OX	OX	OX	OX	OX	OX	OX	OX
Standard Economizer - No Exhaust		Factory	O	O	O	O	O	O	O	X
Standard Economizer Controls (Not for Title 24)										
Single Enthalpy Control	C1SNSR64FF1	53W64	OX	OX	OX	OX	OX	OX	OX	OX
Differential Enthalpy Control (order 2)	C1SNSR64FF1	53W64	X	X	X	X	X	X	X	X
High Performance Economizer With Outdoor Air Hood (Sensible Control) (Approved for California Title 24 Building Standards / AMCA Class 1A Certified)										
High Performance Economizer - Includes Barometric Relief Dampers and Exhaust Hood	K1ECON32A-5	23G22	OX	OX	OX	OX	OX	OX	OX	OX
High Performance Economizer Controls (Not for Title 24)										
Single Enthalpy Control	C1SNSR65FF1	23G26	OX	OX	OX	OX	OX	OX	OX	OX
Differential Enthalpy Control (order 2)	C1SNSR65FF1	23G26	X	X	X	X	X	X	X	X
Economizer Accessories										
Horizontal Economizer Conversion Kit	T1HECK00AN1	17W45	X	X	X	X	X	X	X	X
POWER EXHAUST FAN										
Standard Static	208/230V-1 or 3ph - C1PWRE10A-1P	79W87			X	X	X	X	X	X
<i>NOTE - Field installed Power Exhaust Fan requires "Barometric Relief Dampers for Power Exhaust Kit" for field installation. See below.</i>	460V-3ph - C1PWRE10A-1G	79W88			X	X	X	X	X	X
	575V-3ph - C1PWRE10A-1J	79W89			X	X	X	X	X	X
¹ BAROMETRIC RELIEF										
¹ Barometric Relief Dampers for Power Exhaust Kit	C1DAMP50A-3-	19D42			X	X	X	X	X	X
² Horizontal Barometric Relief Dampers With Exhaust Hood	LAGEDH03/15-2	19F01	X	X	X	X	X	X	X	X
OUTDOOR AIR										
Outdoor Air Dampers With Outdoor Air Hood										
Motorized	C1DAMP21A-1	15D17	OX	OX	OX	OX	OX	OX	OX	OX
Manual	C1DAMP11A-2	15D18	OX	OX	OX	OX	OX	OX	OX	OX
HUMIDITROL® CONDENSER REHEAT OPTION										
Humiditrol Dehumidification Option, includes remote mounted Dehumidistat		Factory	O	O	O	O	O		⁴ O	O
³ Dehumidistat, Remote Mounted	C0SNSR30FF1L	99N41	X	X	X	X	X		⁴ X	X
ELECTRICAL										
Voltage	208/230V - 1 phase		O	O	O	O	O			
60 hz	208/230V - 3 phase				O	O	O	O	O	O
	460V - 3 phase				O	O	O	O	O	O
	575V - 3 phase				O	O	O	O	O	O
Disconnect	See Electrical Data Tables for selection		OX	OX	OX	OX	OX	OX	OX	OX
GFI Service Outlets	15 amp non-powered, field-wired (208/230V, 460V only)	74M70	OX	OX	OX	OX	OX	OX	OX	OX
	20 amp non-powered, field-wired (575V only)	C1GFCI20FF1	67E01	X	X	X	X	X	X	X
Weatherproof Cover for GFI	C1GFCI99FF1	10C89	X	X	X	X	X	X	X	X

¹ Required when Economizer is factory installed with field installed Power Exhaust Fan option.

² Required when Economizer is configured for horizontal airflow.

³ A thermostat with a dehumidification output or a DDC controller with an isolated output can be used instead.

⁴ 074S models only.

NOTE - The catalog and model numbers that appear here are for ordering field installed accessories only.

OX - Field Installed or Configure to Order (Factory Installed)

O - Configure to Order (Factory Installed)

X - Field Installed

OPTIONS / ACCESSORIES

Item	Model No.	Catalog No.	Unit Model No.							
			KGB 024	KGB 030	KGB 036	KGB 048	KGB 060	KGB 072	KGB 074	KGB 090
INDOOR AIR QUALITY										
Air Filters										
Healthy Climate® High Efficiency Air Filters	MERV 8 (16 x 20 x 2) - C1FLTR15A-1-	54W20	X	X	X	X				
	MERV 13 (16 x 20 x 2) - T1FLTR40A-1-	52W37	X	X	X	X				
Order 4 per unit	MERV 8 (20 x 20 x 2) - C1FLTR15D-1-	54W21					X	X	X	X
	MERV 13 (20 x 20 x 2) - C1FLTR40D-1-	52W39					X	X	X	X
Indoor Air Quality (CO ₂) Sensors										
Sensor - Wall-mount, off-white plastic cover with LCD display	C0SNSR50AE1L	77N39	X	X	X	X	X	X	X	X
Sensor - Wall-mount, black plastic case, no display, rated for plenum mounting	C0SNSR53AE1L	87N54	X	X	X	X	X	X	X	X
CO ₂ Sensor Duct Mounting Kit - for downflow applications	C0MISC19AE1-	85L43	X	X	X	X	X	X	X	X
Aspiration Box - for duct mounting non-plenum rated CO ₂ sensor (77N39)	C0MISC16AE1-	90N43	X	X	X	X	X	X	X	X
CEILING DIFFUSERS										
Step-Down - Order one	RTD9-65S	13K60	X	X	X	X	X			
	RTD11-95S	13K61						X	X	X
Flush - Order one	FD9-65S	13K55	X	X	X	X	X			
	FD11-95S	13K56						X	X	X
Transitions (Supply and Return) - Order one	T1TRAN10AN1	17W53	X	X	X	X	X			
	T1TRAN20N-1	17W54						X	X	X
ROOF CURBS										
Hybrid Roof Curbs, Downflow										
8 in. height	C1CURB70A-1	11F50	X	X	X	X	X	X	X	² X
14 in. height	C1CURB71A-1	11F51	X	X	X	X	X	X	X	² X
18 in. height	C1CURB72A-1	11F52	X	X	X	X	X	X	X	² X
24 in. height	C1CURB73A-1	11F53	X	X	X	X	X	X	X	² X
Hybrid Roof Curbs, Full Perimeter, Downflow										
8 in. height	K1CURB70AP1	11S47								X
14 in. height	K1CURB71AP1	11S48								X
18 in. height	K1CURB72AP1	11T01								X
24 in. height	K1CURB73AP1	11T06								X
Adjustable Pitch Curb										
14 in. height	C1CURB55AT1	43W27	X	X	X	X	X	X	X	X

NOTE - The catalog and model numbers that appear here are for ordering field installed accessories only.

OX - Field Installed or Configure to Order (Factory Installed)

O - Configure to Order (Factory Installed)

X - Field Installed

SPECIFICATIONS - DIRECT DRIVE BLOWER
2 TON | 2.5 TON

General Data		Nominal Tonnage	2 Ton	2.5 Ton
		Model No.	KGB024S4E	KGB030S4E
		Efficiency Type	Standard	Standard
		Blower Type	Multi-Speed Direct Drive ECM	Multi-Speed Direct Drive ECM
Cooling Performance	Gross Cooling Capacity - Btuh		24,600	31,000
	¹ Net Cooling Capacity - Btuh		24,000	30,000
	AHRI Rated Air Flow - cfm		810	1,000
	² Sound Rating Number (dBA)		74	74
	Total Unit Power - kW		1.9	2.4
	¹ SEER (Btuh/Watt)		14.0	14.0
	¹ EER (Btuh/Watt)		12.5	11.5
Refrigerant Charge	Refrigerant Type		R-410A	R-410A
	Environ™ Coil System		4 lbs. 1 oz.	5 lbs. 5 oz.
	Conventional Fin/Tube Coil		10 lbs. 0 oz.	10 lbs. 8 oz.
	Conventional Fin/Tube With Humiditrol® Dehumidification Option		9 lbs. 15 oz.	10 lbs. 7 oz.
Gas Heating Options			Standard (1 Stage)	Standard (1 Stage)
Compressor Type (one per unit)			Scroll	Scroll
Outdoor Coil Environ™ (Fin/Tube)	Net face area - sq. ft.		11.7 (15.6)	11.7 (15.6)
	Number of rows		1 (2)	1 (2)
	Fins per inch		23 (20)	23 (20)
Outdoor Coil Fan	Motor - (No.) HP		(1) 1/4	(1) 1/4
	Motor rpm		825	825
	Total Motor Input - watts		335	335
	Diameter - (No.) in. / No. of blades		(1) 24 - 4	(1) 24 - 4
	Total air volume - cfm		3700	3700
Indoor Coil	Net face area - sq. ft.		7.8	7.8
	Tube diameter - in.		3/8	3/8
	Number of rows		2	3
	Fins per inch		14	14
	Drain Connection (no.) and size - in.		(1) 1 NPT	(1) 1 NPT
	Expansion device type		Balanced Port Thermostatic Expansion Valve, removable power head	
Indoor Blower	Nominal Motor HP		0.33 hp (ECM)	0.33 hp (ECM)
	Wheel nominal diameter x width - in.		(1) 10 x 10	(1) 10 x 10
Filters	Type		Disposable	
	Number and size - in.		(4) 16 x 20 x 2	
Electrical Characteristics - 60 Hz			208/230V 1 phase	208/230V 1 phase

NOTE - Net capacity includes evaporator blower motor heat deduction. Gross capacity does not include evaporator blower motor heat deduction.

¹ AHRI Certified to AHRI Standard 210/240: 95°F outdoor air temperature and 80°F db/67°F wb entering evaporator air; minimum external duct static pressure.

² Sound Rating Number rated in accordance with test conditions included in AHRI Standard 270-95.

SPECIFICATIONS - DIRECT DRIVE BLOWER
3 TON | 4 TON

General Data		Nominal Tonnage	3 Ton	3 Ton	4 Ton	4 Ton
		Model No.	KGB036S4E	KGB036S4D	KGB048S4E	KGB048S4D
		Efficiency Type	Standard	Standard	Standard	Standard
		Blower Type	Multi-Speed Direct Drive ECM	Multi-Speed Direct Drive PSC	Multi-Speed Direct Drive ECM	Multi-Speed Direct Drive PSC
Cooling Performance	Gross Cooling Capacity - Btuh		37,300	37,300	49,700	49,700
	¹ Net Cooling Capacity - Btuh		36,000	36,000	47,500	47,500
	AHRI Rated Air Flow - cfm		1150	1150	1560	1560
	² Sound Rating Number (dBA)		74	74	74	74
	Total Unit Power - kW		2.9	2.9	4.1	4.1
	¹ SEER (Btuh/Watt)		14.0	14.0	14.0	14.0
	¹ EER (Btuh/Watt)		12.3	12.3	11.5	11.5
Refrigerant Charge	Refrigerant Type		R-410A	R-410A	R-410A	R-410A
	Environ™ Coil System		5 lbs. 9 oz.	5 lbs. 9 oz.	5 lbs. 10 oz.	5 lbs. 10 oz.
	Conventional Fin/Tube Coil		11 lbs. 3 oz.	11 lbs. 3 oz.	9 lbs. 13 oz.	9 lbs. 13 oz.
	Conventional Fin/Tube With Humiditrol® Dehumidification Option		12 lbs. 7 oz.	12 lbs. 7 oz.	9 lbs. 13 oz.	9 lbs. 13 oz.
Gas Heating Options			Standard (1 or 2 Stage) Medium (1 or 2 Stage)			Standard (1 or 2 Stage) Medium (1 or 2 Stage) High (1 or 2 Stage)
Compressor Type (one per unit)			Scroll	Scroll	Scroll	Scroll
Outdoor Coil Environ™ (Fin/Tube)	Net face area - sq. ft.		14.5 (15.6)	14.5 (15.6)	14.5 (15.6)	14.5 (15.6)
	Number of rows		1 (2)	1 (2)	1 (2)	1 (2)
	Fins per inch		23 (20)	23 (20)	23 (20)	23 (20)
Outdoor Coil Fan	Motor - (No.) HP		(1) 1/4	(1) 1/4	(1) 1/4	(1) 1/4
	Motor rpm		825	825	825	825
	Total Motor Input - watts		325	325	325	325
	Diameter - (No.) in. / No. of blades		(1) 24 - 4	(1) 24 - 4	(1) 24 - 4	(1) 24 - 4
	Total air volume - cfm		3950	3950	3950	3950
Indoor Coil	Net face area - sq. ft.		7.8	7.8	7.8	7.8
	Tube diameter - in.		3/8	3/8	3/8	3/8
	Number of rows		3	3	3	3
	Fins per inch		14	14	14	14
	Drain Connection (no.) and size - in.		(1) 1 NPT	(1) 1 NPT	(1) 1 NPT	(1) 1 NPT
	Expansion device type		Balanced Port Thermostatic Expansion Valve, removable power head			
Indoor Blower	Nominal Motor HP		0.50 hp (ECM)	0.50 hp (PSC)	0.75 hp (ECM)	0.50 hp (PSC)
	Wheel nominal diameter x width - in.		(1) 10 x 10	(1) 10 x 10	(1) 10 x 10	(1) 10 x 10
Filters	Type		Disposable			
	Number and size - in.		(4) 16 x 20 x 2			
Electrical Characteristics - 60 Hz			208/230V 1 phase	208/230V, 460V & 575V 3 phase	208/230V 1 phase	208/230V, 460V & 575V 3 phase

NOTE - Net capacity includes evaporator blower motor heat deduction. Gross capacity does not include evaporator blower motor heat deduction.

¹ AHRI Certified to AHRI Standard 210/240: 95°F outdoor air temperature and 80°F db/67°F wb entering evaporator air; minimum external duct static pressure.

² Sound Rating Number rated in accordance with test conditions included in AHRI Standard 270-95.

SPECIFICATIONS - DIRECT DRIVE BLOWER
5 TON

General Data		Nominal Tonnage	5 Ton	5 Ton
		Model No.	KGB060S4E	KGB060S4D
		Efficiency Type	Standard	Standard
		Blower Type	Multi-Speed Direct Drive ECM	Multi-Speed Direct Drive PSC
Cooling Performance	Gross Cooling Capacity - Btuh		60,900	60,900
	¹ Net Cooling Capacity - Btuh		58,500	58,500
	AHRI Rated Air Flow - cfm		1760	1760
	² Sound Rating Number (dBA)		83	83
	Total Unit Power - kW		5.0	5.0
	¹ SEER (Btuh/Watt)		14.0	14.0
	¹ EER (Btuh/Watt)		11.0	11.0
Refrigerant Charge	Refrigerant Type		R-410A	R-410A
	Environ™ Coil System		8 lbs. 0 oz.	8 lbs. 0 oz.
	Conventional Fin/Tube Coil		14 lbs. 3 oz.	14 lbs. 3 oz.
	Conventional Fin/Tube With Humiditrol® Dehumidification Option		15 lbs. 3 oz.	15 lbs. 3 oz.
Gas Heating Options			Standard (2 Stage) Medium (2 Stage) High (2 Stage)	Standard (1 or 2 Stage) Medium (1 or 2 Stage) High (1 or 2 Stage)
Compressor Type (one per unit)			Scroll	Scroll
Outdoor Coil Environ™ (Fin/Tube)	Net face area - sq. ft.		17.8 (19.3)	17.8 (19.3)
	Number of rows		1 (2)	1 (2)
	Fins per inch		23 (20)	23 (20)
Outdoor Coil Fan	Motor - (No.) HP		(1) 1/3	(1) 1/3
	Motor rpm		1075	1075
	Total Motor Input - watts		375	375
	Diameter - (No.) in. / No. of blades		(1) 24 - 3	(1) 24 - 3
	Total air volume - cfm		4700	4700
	Indoor Coil	Net face area - sq. ft.		9.7
Tube diameter - in.			3/8	3/8
Number of rows			4	4
Fins per inch			14	14
Drain Connection (no.) and size - in.			(1) 1 NPT	(1) 1 NPT
Expansion device type			Balanced Port Thermostatic Expansion Valve, removable power head	
Indoor Blower	Nominal Motor HP		1 hp (ECM)	0.75 hp (PSC)
	Wheel nominal diameter x width - in.		(1) 11 x 10	(1) 11 x 10
Filters	Type		Disposable	
	Number and size - in.		(4) 20 x 20 x 2	
Electrical Characteristics - 60 Hz			208/230V 1 phase	208/230V, 460V & 575V 3 phase

NOTE - Net capacity includes evaporator blower motor heat deduction. Gross capacity does not include evaporator blower motor heat deduction.

¹ AHRI Certified to AHRI Standard 210/240: 95°F outdoor air temperature and 80°F db/67°F wb entering evaporator air; minimum external duct static pressure.

² Sound Rating Number rated in accordance with test conditions included in AHRI Standard 270-95.

SPECIFICATIONS - BELT DRIVE BLOWER		SINGLE SPEED - 3 TON 4 TON 5 TON				
General Data		Nominal Tonnage	3 Ton	4 Ton	5 Ton	
		Model No.	KGB036S4B	KGB048S4B	KGB060S4B	
		Efficiency Type	Standard	Standard	Standard	
		Blower Type	Single Speed Belt Drive	Single Speed Belt Drive	Single Speed Belt Drive	
Cooling Performance	Gross Cooling Capacity - Btuh		37,300	49,700	60,900	
	¹ Net Cooling Capacity - Btuh		36,000	47,500	58,500	
	AHRI Rated Air Flow - cfm		1150	1560	1760	
	² Sound Rating Number (dBA)		74	74	83	
	Total Unit Power - kW		2.9	4.1	5	
	¹ SEER (Btuh/Watt)		14.0	14.0	14.0	
	¹ EER (Btuh/Watt)		12.3	11.5	11.0	
Refrigerant Charge	Refrigerant Type		R-410A	R-410A	R-410A	
	Environ™ Coil System		5 lbs. 9 oz.	5 lbs. 10 oz.	8 lbs. 0 oz.	
	Conventional Fin/Tube Coil		11 lbs. 3 oz.	9 lbs. 13 oz.	14 lbs. 3 oz.	
	Conventional Fin/Tube With Humiditrol® Dehumidification Option		12 lbs. 7 oz.	9 lbs. 13 oz.	15 lbs. 3 oz.	
Gas Heating Options			Standard (1 or 2 Stage) Medium (1 or 2 Stage)	Standard (1 or 2 Stage) Medium (1 or 2 Stage) High (1 or 2 Stage)		
Compressor Type (one per unit)			Scroll	Scroll	Scroll	
Outdoor Coil Environ™ (Fin/Tube)	Net face area - sq. ft.		14.5 (15.6)	14.5 (15.6)	17.8 (19.3)	
	Number of rows		1 (2)	1 (2)	1 (2)	
	Fins / inch		23 (20)	23 (20)	23 (20)	
Outdoor Coil Fan	Motor - (No.) HP		(1) 1/4	(1) 1/4	(1) 1/3	
	Motor rpm		825	825	1075	
	Total Motor Input - watts		325	325	375	
	Diameter - (No.) in. / No. of blades		(1) 24 - 4	(1) 24 - 4	(1) 24 - 3	
	Total air volume - cfm		3950	3950	4700	
	Indoor Coil	Net face area - sq. ft.		7.8	7.8	9.7
Tube diameter - in.			3/8	3/8	3/8	
Number of rows			3	3	4	
Fins per inch			14	14	14	
Drain Connection (no.) and size - in.			(1) 1 NPT	(1) 1 NPT	(1) 1 NPT	
Expansion device type			Balanced Port Thermostatic Expansion Valve, removable power head			
³ Indoor Blower & Drive Selection		Nominal Motor HP		1 hp, 2 hp	1 hp, 2 hp	1 hp, 2 hp
	Maximum Usable Motor Output (US Only)		1.15 hp, 2.3 hp	1.15 hp, 2.3 hp	1.15 hp, 2.3 hp	
	Available Drive Kits	A01		673 - 1010 rpm	A02	745 - 1117 rpm
		A05		897 - 1346 rpm	A06	1071 - 1429 rpm
		A03		833 - 1250 rpm	A07	1212 - 1548 rpm
Wheel nominal diameter x width - in.		(1) 10 x 10	(1) 10 x 10	(1) 10 x 10		
Filters	Type		Disposable			
	Number and size - in.		(4) 16 x 20 x 2		(4) 20 x 20 x 2	
Electrical Characteristics - 60 Hz			208/230V, 460V or 575V – 60 hertz – 3 phase			

NOTE - Net capacity includes evaporator blower motor heat deduction. Gross capacity does not include evaporator blower motor heat deduction.

¹ AHRI Certified to AHRI Standard 210/240: 95°F outdoor air temperature and 80°F db/67°F wb entering evaporator air; minimum external duct static pressure.

² Sound Rating Number rated in accordance with test conditions included in AHRI Standard 270-95.

³ Using total air volume and system static pressure requirements determine from blower performance tables rpm and motor hp required. Maximum usable hp of motors furnished are shown. In Canada, nominal motor hp is also maximum usable motor hp output. If motors of comparable hp are used, be sure to keep within the service factor limitations outlined on the motor nameplate.

SPECIFICATIONS - BELT DRIVE BLOWER
SINGLE SPEED - 6 TON

General Data		Nominal Tonnage	6 Ton	6 Ton	
		Model No.	KGB072H4B	KGB074S4B	
		Efficiency Type	High	Standard	
		Blower Type	Single Speed Belt Drive	Single Speed Belt Drive	
Cooling Performance	Gross Cooling Capacity - Btuh		73,500	71,000	
	¹ Net Cooling Capacity - Btuh		72,000	68,000	
	AHRI Rated Air Flow - cfm		1920	2150	
	² Sound Rating Number (dBA)		79	79	
	Total Unit Power - kW		6.0	6.1	
	¹ IEER		13.5	12.7	
	¹ EER (Btuh/Watt)		12.0	11.0	
Refrigerant Charge	Refrigerant Type		R-410A	R-410A	
	Environ™ Coil System		7 lbs. 8 oz.	7 lbs. 2 oz.	
	Conventional Fin/Tube Coil		- - -	14 lbs. 8 oz.	
Conventional Fin/Tube With Humiditrol® Dehumidification Option			- - -	14 lbs. 11 oz.	
Gas Heating Options			Standard (1 or 2 Stage) Medium (1 or 2 Stage) High (1 or 2 Stage)	Standard (1 Stage) Medium (1 or 2 Stage) High (1 or 2 Stage)	
Compressor Type (one per unit)			Scroll	Two-Stage Scroll	
Outdoor Coil Environ™ (Fin/Tube)	Net face area - sq. ft.		17.8	17.8 (19.3)	
	Number of rows		1	1 (2)	
	Fins / inch		23	23 (20)	
Outdoor Coil Fan	Motor - (No.) HP		(1) 1/3	(1) 1/3	
	Motor rpm		1075	1075	
	Total Motor Input - watts		410	375	
	Diameter - (No.) in. / No. of blades		(1) 24 - 3	(1) 24 - 3	
	Total air volume - cfm		4800	4700	
Indoor Coil	Net face area - sq. ft.		9.72	9.72	
	Tube diameter - in.		3/8	3/8	
	Number of rows		4	4	
	Fins per inch		14	14	
	Drain Connection (no.) and size - in.		(1) 1 NPT	(1) 1 in. NPT	
	Expansion device type		Balanced Port Thermostatic Expansion Valve, removable power head		
³ Indoor Blower & Drive Selection	Nominal Motor Output		1 hp, 2 hp	1 hp, 2 hp	
	Maximum Usable Motor Output (US Only)		1.15 hp, 2.3 hp	1.15 hp 2.3 hp	
	Motor - Drive Kit Number	AA01		522-784 rpm	968 - 1340 rpm
		AA02		632-875 rpm	A08
		AA03		798-1105 rpm	1193-1591 rpm
Wheel Nominal Diameter x Width - in.			(1) 15 x 9	10 X 10	
Filters	Type		Disposable	Disposable	
	Number and size - in.		(4) 20 x 20 x 2	(4) 20 x 20 x 2	
Electrical Characteristics - 60 Hz			208/230V, 460V or 575V - 60 hertz - 3 phase		

NOTE - Net capacity includes evaporator blower motor heat deduction. Gross capacity does not include evaporator blower motor heat deduction.

¹ AHRI Certified to AHRI Standard 340/360: 95°F outdoor air temperature and 80°F db/67°F wb entering evaporator air; minimum external duct static pressure.

² Sound Rating Number rated in accordance with test conditions included in AHRI Standard 270-95.

³ Using total air volume and system static pressure requirements determine from blower performance tables rpm and motor hp required. Maximum usable hp of motors furnished are shown. In Canada, nominal motor hp is also maximum usable motor hp output. If motors of comparable hp are used, be sure to keep within the service factor limitations outlined on the motor nameplate.

SPECIFICATIONS - BELT DRIVE BLOWER
TWO-SPEED - 6 TON

General Data		Nominal Tonnage	6 Ton	6 Ton	
		Model No.	KGB074S4T	KGB074H4T	
		Efficiency Type	Standard	High	
		Blower Type	Two Speed Belt Drive	Two Speed Belt Drive	
Cooling Performance	Gross Cooling Capacity - Btuh		71,000	72,000	
	¹ Net Cooling Capacity - Btuh		68,000	69,000	
	AHRI Rated Air Flow - cfm		2100	2100	
	² Sound Rating Number (dBA)		79	79	
	Total Unit Power - kW		6.1	5.7	
	¹ IEER		15.0	16.0	
	¹ EER (Btuh/Watt)		11.2	12.0	
Refrigerant Charge	Refrigerant Type		R-410A	R-410A	
	Environ™ Coil System		7 lbs. 2 oz.	7 lbs. 2 oz.	
	Conventional Fin/Tube Coil		14 lbs. 8 oz.	---	
Conventional Fin/Tube With Humiditrol® Dehumidification Option			14 lbs. 11 oz.	---	
Gas Heating Options			Standard (1 or 2 Stage), Medium (1 or 2 Stage), or High (1 or 2 Stage)	Standard (1 or 2 Stage), Medium (1 or 2 Stage), or High (1 or 2 Stage)	
Compressor Type (one per unit)			Two-Stage Scroll	Two-Stage Scroll	
Outdoor Coil Environ™ (Fin/Tube)	Net face area - sq. ft.		17.8 (19.3)	17.8	
	Number of rows		1 (2)	1	
	Fins / inch		23 (20)	23	
Outdoor Coil Fan	Motor - (No.) HP		(1) 1/3	(1) 1/3	
	Motor rpm		1075	1075	
	Total Motor Input - watts		375	375	
	Diameter - (No.) in. / No. of blades		(1) 24 - 3	(1) 24 - 3	
	Total air volume - cfm		4700	4700	
Indoor Coil	Net face area - sq. ft.		9.72	9.72	
	Tube diameter - in.		3/8	3/8	
	Number of rows		4	4	
	Fins per inch		14	14	
	Drain Connection (no.) and size - in.		(1) 1 NPT	(1) 1 NPT	
	Expansion device type		Balanced Port Thermostatic Expansion Valve, removable power head		
³ Indoor Blower & Drive Selection	Nominal Motor Output		1 hp, 2 hp	1 hp, 2 hp	
	Maximum Usable Motor Output (US Only)		1.15 hp, 2.3 hp	1.15 hp, 2.3 hp	
	Motor - Drive Kit Number	A04		968 - 1340 rpm	AA01 522-784 rpm
		A08		1193-1591 rpm	AA02 632-875 rpm
					AA03 798-1105 rpm
Wheel Nominal Diameter x Width - in.		(1) 10 x 10	(1) 15 x 9		
Filters	Type		Disposable		
	Number and size - in.		(4) 20 x 20 x 2	(4) 20 x 20 x 2	
Electrical Characteristics - 60 Hz			208/230V, 460V or 575V - 60 hertz - 3 phase		

NOTE - Net capacity includes evaporator blower motor heat deduction. Gross capacity does not include evaporator blower motor heat deduction.

¹ AHRI Certified to AHRI Standard 340/360: 95°F outdoor air temperature and 80°F db/67°F wb entering evaporator air; minimum external duct static pressure.

² Sound Rating Number rated in accordance with test conditions included in AHRI Standard 270-95.

³ Using total air volume and system static pressure requirements determine from blower performance tables rpm and motor hp required. Maximum usable hp of motors furnished are shown. In Canada, nominal motor hp is also maximum usable motor hp output. If motors of comparable hp are used, be sure to keep within the service factor limitations outlined on the motor nameplate.

SPECIFICATIONS - BELT DRIVE BLOWER
SINGLE AND TWO-SPEED - 7.5 TON

General Data		Nominal Tonnage	7.5 Ton	7.5 Ton	
		Model No.	KGB090S4B	KGB090S4T	
		Efficiency Type	Standard	Standard	
		Blower Type	Single Speed Belt Drive	Two Speed Belt Drive	
Cooling Performance	Gross Cooling Capacity - Btuh		92,000	92,000	
	¹ Net Cooling Capacity - Btuh		88,000	88,000	
	AHRI Rated Air Flow - cfm		2250	2250	
	² Sound Rating Number (dBA)		79	79	
	Total Unit Power - kW		8.0	8.0	
	¹ IEER		12.7	14.0	
	¹ EER (Btuh/Watt)		11.0	11.0	
Refrigerant Charge	Refrigerant Type		R-410A	R-410A	
	Environ™ Coil System		9 lbs. 4 oz.	9 lbs. 4 oz.	
	Conventional Fin/Tube Coil		17 lbs. 14 oz.	17 lbs. 14 oz.	
Conventional Fin/Tube With Humiditrol® Dehumidification Option			19 lbs. 14 oz.	19 lbs. 14 oz.	
Gas Heating Options			Medium (1 or 2 stage) High (1 or 2 stage)	Medium (1 or 2 stage) High (1 or 2 stage)	
Compressor Type (one per unit)			Two-Stage Scroll	Two-Stage Scroll	
Outdoor Coil Environ™ (Fin/Tube)	Net face area - sq. ft.		24.2 (27.7)	24.2 (27.7)	
	Number of rows		1 (2)	1 (2)	
	Fins / inch		23 (20)	23 (20)	
Outdoor Coil Fan	Motor - (No.) HP		(1) 1/2	(1) 1/2	
	Motor rpm		1075	1075	
	Total Motor Input - watts		520	520	
	Diameter - (No.) in. / No. of blades		(1) 24 - 4	(1) 24 - 4	
	Total air volume - cfm		5300	5300	
Indoor Coil	Net face area - sq. ft.		9.72	9.72	
	Tube diameter - in.		3/8	3/8	
	Number of rows		4	4	
	Fins per inch		14	14	
	Drain Connection (no.) and size - in.		(1) 1 in. NPT	(1) 1 in. NPT	
Expansion device type			Balanced Port Thermostatic Expansion Valve, removable power head		
³ Indoor Blower & Drive Selection	Nominal Motor Output		1 hp, 2 hp, 3hp	2 hp	
	Maximum Usable Motor Output (US Only)		1.15 hp 2.3 hp, 3.45 hp	2.3 hp	
	Motor - Drive Kit Number	AA01		522-784 rpm	522-784 rpm
		AA02		632-875 rpm	632-875 rpm
		AA03		798-1105 rpm	798-1105 rpm
		⁴ AA04		921-1228	921-1228
Wheel Nominal Diameter x Width - in.		(1) 15 x 9	(1) 15 x 9		
Filters	Type		Disposable		
	Number and size - in.		(4) 20 x 20 x 2	(4) 20 x 20 x 2	
Electrical Characteristics - 60 Hz			208/230V, 460V or 575V – 60 hertz – 3 phase		

NOTE - Net capacity includes evaporator blower motor heat deduction. Gross capacity does not include evaporator blower motor heat deduction.

¹ AHRI Certified to AHRI Standard 340/360: 95°F outdoor air temperature and 80°F db/67°F wb entering evaporator air; minimum external duct static pressure.

² Sound Rating Number rated in accordance with test conditions included in AHRI Standard 270-95.

³ Using total air volume and system static pressure requirements determine from blower performance tables rpm and motor hp required. Maximum usable hp of motors furnished are shown. In Canada, nominal motor hp is also maximum usable motor hp output. If motors of comparable hp are used, be sure to keep within the service factor limitations outlined on the motor nameplate.

⁴ 3 hp blower motor only.

SPECIFICATIONS - STANDARD GAS HEAT **THREE PHASE MODELS**

Model No.		036 048 060 074S	072H 074H	036 048 060 074S	072H 074H 090S	036 048 060 074S	072H 074H 090S	048 060 074S	072H 074H 090S	048 060 074S	072H 074H 090S
Heat Input Type		Standard (1 Stage)		Medium (1 Stage)		Medium (2 Stage)		High (1 Stage)		High (2 Stage)	
Input Btuh	1st Stage	65,000		108,000		81,000		150,000		113,000	
	2nd Stage	---		---		108,000		---		150,000	
Output Btuh	1st Stage	52,000		86,000		65,000		120,000		90,000	
	2nd Stage	---		---		86,000		---		120,000	
Temperature Rise Range - °F	1st stage	---	---	30 - 70	15 - 45	25 - 55	10 - 40	---	---	30 - 60	15 - 45
	2nd Stage	15 - 45	5 - 35	---	---	30 - 70	15 - 45	45 - 75	25 - 55	45 - 75	25 - 55
¹ Thermal Efficiency	Standard	80%		80%	80%	80%	80%	80%	80%	80%	80%
Gas Supply Connections		1/2 in. NPT									
Rec. Gas Supply Pressure - Nat./ LPG		7 in.w.g. / 11 in.w.g.									

¹ Thermal Efficiency at full input.

SPECIFICATIONS - LOW NOx GAS HEAT **SINGLE AND THREE PHASE MODELS**

Model No.		024 030	036 048 060 074S	072H 074H	036 048 060 074S	072H 074H	036 048 060 074S	072 074	036 048 060 074S	072H 074H	048 060 074S	072H 074H	048 060 074S	072H 074H
Heat Input Type		Standard (1 Stage)		Standard (2 Stage) Low NOx Only		Medium (1 Stage)		Medium (2 Stage)		High (1 Stage)		High (2 Stage)		
Input Btuh	1st Stage	65,000		53,000		108,000		81,000		150,000		113,000		
	2nd Stage	---		70,000		---		108,000		---		150,000		
Output Btuh	1st Stage	52,000		43,000		87,000		66,000		121,000		92,000		
	2nd Stage	---		57,000		---		87,000		---		121,000		
Temperature Rise Range - °F	1st stage	35 - 65	15 - 45	5-35	5-35	5-35	30 - 70	15 - 45	25 - 55	10 - 40	---	---	30 - 60	15 - 45
	2nd Stage	---	---	---	15-45	10-40	---	---	30 - 70	15 - 45	45 - 75	25 - 55	45 - 75	25 - 55
¹ AFUE (single phase)		81%	81%	81%	81%	81%	81%	81%	81%	81%	81%	81%	81%	81%
² Thermal Efficiency (three phase)		81%	81%	81%	81%	81%	81%	81%	81%	81%	81%	81%	81%	81%
Gas Supply Connections		1/2 in. NPT												
Rec. Gas Supply Pressure - Nat./ LPG		7 in.w.g. / 11 in.w.g.												

¹ Annual Fuel Utilization Efficiency based on U.S. DOE test procedures and FTC labeling regulations - 1 phase models only.

² Thermal Efficiency at full input.

HIGH ALTITUDE DERATE

<p>NOTE - Units may be installed at altitudes up to 2000 ft. above sea level without any modifications. At altitudes above 2000 ft. units must be derated to match information in the table shown. At altitudes above 4500 ft. unit must be derated 2% for each 1000 ft. above sea level.</p> <p>NOTE - This is the only permissible derate for these units.</p>	Heat Input Type	Altitude Feet	Gas Manifold Pressure in. w.g.		Input Rate (Btuh)
			Natural Gas	LPG/ Propane	
	Standard (1 stage)	2001 - 4500	3.0	9.0	60,000
	Standard (2 stage)	2001 - 4500	3.0/1.7	9.0/5.1	65,000 / 49,000
	Medium (1 stage)	2001 - 4500	3.0	9.0	100,000
	Medium (2 stage)	2001 - 4500	3.0/1.7	9.0/5.1	100,000 / 75,000
	High (1 stage)	2001 - 4500	3.0	9.0	139,000
High (2 stage)	2001 - 4500	3.0/1.7	9.0/5.1	139,000 / 104,000	

BLOWER DATA

DIRECT DRIVE ECM - 2 TON | 2.5 TON

KGB024S4E | KGB030S4E

BLOWER TABLE INCLUDES RESISTANCE FOR BASE UNIT ONLY WITH DRY INDOOR COIL AND AIR FILTERS IN PLACE.

FOR ALL UNITS ADD:

- 1 - Any factory installed options air resistance (heat section, economizer, etc.).
- 2 - Any field installed accessories air resistance (duct resistance, diffuser, etc.).

See page 29 for wet coil and options/accessory air resistance data.

DOWNFLOW

External Static Press. in. w.g.	Air Volume (cfm) at Various Blower Speeds					
	Blower Only	Low Speed		High Speed		Free Cooling
	Low and High Speed: G (Pin 1)	Cooling: Y1 (Pin 2 and 5)	1st Stage Heating: W1 (Pin 2) 2nd Stage Heating: W2 (Pin 2 and 4)	1st Stage Heating: W1 (Pin 3) 2nd Stage Heating: W2 (Pin 3 and 4)	Cooling: Y1 (Pin 3 and 5)	Low and High Speed: Y1 (Pin 1 and 5)
0	488	985	1127	1353	1127	1127
0.1	421	913	1082	1311	1082	1082
0.2	333	841	1037	1269	1037	1037
0.3	285	754	988	1224	988	988
0.4	215	668	923	1180	923	923
0.5	---	611	858	1135	858	858
0.6	---	553	809	1076	809	809
0.7	---	481	760	1017	760	760
0.8	---	---	694	972	694	694
0.9	---	---	646	928	646	646
1.0	---	---	580	869	580	580

HORIZONTAL

External Static Press. in. w.g.	Air Volume (cfm) at Various Blower Speeds					
	Blower Only	Low Speed		High Speed		Free Cooling
	Low and High Speed: G (Pin 1)	Cooling: Y1 (Pin 2 and 5)	1st Stage Heating: W1 (Pin 2) 2nd Stage Heating: W2 (Pin 2 and 4)	1st Stage Heating: W1 (Pin 3) 2nd Stage Heating: W2 (Pin 3 and 4)	Cooling: Y1 (Pin 3 and 5)	Low and High Speed: Y1 (Pin 1 and 5)
0	479	965	1104	1326	1104	1104
0.1	412	895	1060	1285	1060	1060
0.2	326	824	1016	1244	1016	1016
0.3	280	739	968	1200	968	968
0.4	211	655	905	1156	905	905
0.5	---	599	841	1112	841	841
0.6	---	542	793	1054	793	793
0.7	---	471	745	997	745	745
0.8	---	---	680	953	680	680
0.9	---	---	633	909	633	633
1.0	---	---	568	852	568	568

BLOWER DATA

DIRECT DRIVE ECM - 3 TON

KGB036S4E

BLOWER TABLE INCLUDES RESISTANCE FOR BASE UNIT ONLY WITH DRY INDOOR COIL AND AIR FILTERS IN PLACE.

FOR ALL UNITS ADD:

- 1 - Any factory installed options air resistance (heat section, economizer, etc.).
- 2 - Any field installed accessories air resistance (duct resistance, diffuser, etc.).

See page 29 for wet coil and options/accessory air resistance data.

DOWNFLOW

External Static Press. in. w.g.	Air Volume (cfm) at Various Blower Speeds						
	Blower Only	Low Speed		High Speed			Free Cooling
	Low and High Speed: G (Pin 1)	1st Stage Heating: W1 (Pin 2) Cooling: Y1 (Pin 2 and 5)	2nd Stage Heating: W2 (Pin 2 and 4)	1st Stage Heating: W1 (Pin 3)	2nd Stage Heating: W2 (Pin 3 and 4)	Cooling: Y1 (Pin 3 and 5)	Low and High Speed: Y1 (Pin 1 and 5)
0	862	1375	1567	1706	1840	1567	1567
0.1	809	1330	1539	1682	1780	1539	1539
0.2	741	1277	1511	1658	1748	1511	1511
0.3	680	1253	1477	1624	1712	1477	1477
0.4	622	1200	1443	1598	1677	1443	1443
0.5	555	1150	1409	1564	1638	1409	1409
0.6	---	1095	1364	1530	1608	1364	1364
0.7	---	1052	1330	1496	1577	1330	1330
0.8	---	1004	1296	1444	1528	1296	1296
0.9	---	950	1251	1419	1491	1251	1251
1.0	---	900	1206	1394	1455	1206	1206

HORIZONTAL

External Static Press. in. w.g.	Air Volume (cfm) at Various Blower Speeds						
	Blower Only	Low Speed		High Speed			Free Cooling
	Low and High Speed: G (Pin 1)	1st Stage Heating: W1 (Pin 2) Cooling: Y1 (Pin 2 and 5)	2nd Stage Heating: W2 (Pin 2 and 4)	1st Stage Heating: W1 (Pin 3)	2nd Stage Heating: W2 (Pin 3 and 4)	Cooling: Y1 (Pin 3 and 5)	Low and High Speed: Y1 (Pin 1 and 5)
0	479	1379	1536	1672	1810	1536	1536
0.1	412	1305	1508	1648	1749	1508	1508
0.2	326	1264	1481	1625	1718	1481	1481
0.3	280	1216	1447	1592	1677	1447	1447
0.4	211	1173	1414	1566	1649	1414	1414
0.5	---	1131	1381	1533	1622	1381	1381
0.6	---	1078	1337	1499	1577	1337	1337
0.7	---	1038	1303	1466	1544	1303	1303
0.8	---	986	1270	1415	1509	1270	1270
0.9	---	933	1226	1391	1471	1226	1226
1.0	---	885	1182	1366	1438	1182	1182

BLOWER DATA

DIRECT DRIVE ECM - 4 TON

KGB048S4E

BLOWER TABLE INCLUDES RESISTANCE FOR BASE UNIT ONLY WITH DRY INDOOR COIL AND AIR FILTERS IN PLACE.

FOR ALL UNITS ADD:

1 - Any factory installed options air resistance (larger gas heat section, economizer, wet coil, etc.) See page 29.

2 - Any field installed accessories air resistance (duct resistance, diffuser, etc.) See page 30.

DOWNFLOW

External Static Press. in. w.g.	Air Volume (cfm) at Various Blower Speeds					
	Blower Only	Low Speed		High Speed		Free Cooling
	Low and High Speed: G (Pin 1)	Cooling: Y1 (Pin 2 and 5)	1st Stage Heating: W1 (Pin 2) 2nd Stage Heating: W2 (Pin 2 and 4)	2nd Stage Heating: W2 (Pin 3 and 4)	1st Stage Heating: W1 (Pin 3) Cooling: Y1 (Pin 3 and 5)	Low and High Speed: Y1 (Pin 1 and 5)
0	963	1561	1869	2156	1869	1958
0.1	897	1530	1842	2132	1842	1920
0.2	831	1499	1815	2108	1815	1882
0.3	752	1466	1788	2084	1788	1844
0.4	673	1432	1750	2057	1750	1814
0.5	620	1398	1723	2031	1723	1784
0.6	567	1353	1695	1991	1695	1754
0.7	501	1319	1658	1952	1658	1724
0.8	---	1274	1621	1899	1621	1694
0.9	---	1240	1593	1794	1593	1672
1.0	---	1184	1556	1689	1556	1650

HORIZONTAL

External Static Press. in. w.g.	Air Volume (cfm) at Various Blower Speeds					
	Blower Only	Low Speed		High Speed		Free Cooling
	Low and High Speed: G (Pin 1)	Cooling: Y1 (Pin 2 and 5)	1st Stage Heating: W1 (Pin 2) 2nd Stage Heating: W2 (Pin 2 and 4)	2nd Stage Heating: W2 (Pin 3 and 4)	1st Stage Heating: W1 (Pin 3) Cooling: Y1 (Pin 3 and 5)	Low and High Speed: Y1 (Pin 1 and 5)
0	944	1530	1832	2113	1832	1919
0.1	879	1499	1805	2089	1805	1882
0.2	814	1469	1779	2066	1779	1844
0.3	737	1437	1752	2042	1752	1807
0.4	660	1403	1715	2016	1715	1778
0.5	608	1370	1689	1990	1689	1748
0.6	556	1326	1661	1951	1661	1719
0.7	491	1293	1625	1913	1625	1690
0.8	---	1249	1589	1861	1589	1660
0.9	---	1215	1561	1758	1561	1639
1.0	---	1160	1525	1655	1525	1617

BLOWER DATA

DIRECT DRIVE ECM - 5 TON

KGB060S4E

BLOWER TABLE INCLUDES RESISTANCE FOR BASE UNIT ONLY WITH DRY INDOOR COIL AND AIR FILTERS IN PLACE.

FOR ALL UNITS ADD:

1 - Any factory installed options air resistance (larger gas heat section, economizer, wet coil, etc.) See page 29.

2 - Any field installed accessories air resistance (duct resistance, diffuser, etc.) See page 30.

DOWNFLOW

External Static Press. in. w.g.	Air Volume (cfm) at Various Blower Speeds						
	Blower Only	Low Speed		High Speed			Free Cooling
	Low and High Speed: G (Pin 1)	1st Stage Heating: W1 (Pin 2) Cooling: Y1 (Pin 2 and 5)	2nd Stage Heating: W2 (Pin 2 and 4)	1st Stage Heating: W1 (Pin 3)	2nd Stage Heating: W2 (Pin 3 and 4)	Cooling: Y1 (Pin 3 and 5)	Low and High Speed: Y1 (Pin 1 and 5)
0	1088	1801	1982	1801	2339	2287	2287
0.1	1042	1769	1956	1769	2310	2251	2251
0.2	996	1736	1928	1736	2281	2215	2215
0.3	948	1703	1900	1703	2253	2178	2178
0.4	883	1669	1870	1669	2224	2142	2142
0.5	835	1634	1838	1634	2195	2106	2106
0.6	787	1598	1806	1598	2166	2058	2058
0.7	723	1561	1772	1561	2137	2010	2010
0.8	658	1524	1736	1524	2108	1937	1937
0.9	594	1486	1700	1486	2080	1841	1841
1.0	546	1446	1662	1446	2051	1696	1696

HORIZONTAL

External Static Press. in. w.g.	Air Volume (cfm) at Various Blower Speeds						
	Blower Only	Low Speed		High Speed			Free Cooling
	Low and High Speed: G (Pin 1)	1st Stage Heating: W1 (Pin 2) Cooling: Y1 (Pin 2 and 5)	2nd Stage Heating: W2 (Pin 2 and 4)	1st Stage Heating: W1 (Pin 3)	2nd Stage Heating: W2 (Pin 3 and 4)	Cooling: Y1 (Pin 3 and 5)	Low and High Speed: Y1 (Pin 1 and 5)
0	1066	1728	1886	1728	2206	2241	2241
0.1	1021	1708	1872	1708	2189	2206	2206
0.2	976	1685	1859	1685	2174	2171	2171
0.3	929	1661	1832	1661	2157	2134	2134
0.4	865	1636	1814	1636	2135	2099	2099
0.5	818	1608	1796	1608	2118	2064	2064
0.6	771	1579	1770	1579	2102	2017	2017
0.7	709	1548	1743	1548	2080	1970	1970
0.8	645	1516	1716	1516	2058	1898	1898
0.9	582	1481	1689	1481	2036	1804	1804
1.0	535	1445	1654	1445	2020	1662	1662

BLOWER DATA**DIRECT DRIVE PSC - 3 TON | 4 TON****KGB036S4D | KGB048S4D****BLOWER TABLE INCLUDES RESISTANCE FOR BASE UNIT ONLY WITH DRY INDOOR COIL AND AIR FILTERS IN PLACE.**

FOR ALL UNITS ADD:

1 - Any factory installed options air resistance (larger gas heat section, economizer, wet coil, etc.) See page 29.

2 - Any field installed accessories air resistance (duct resistance, diffuser, etc.) See page 30.

External Static Pressure (in. w.g.)	Air Volume (cfm) at Various Blower Speeds								
	208 VOLTS			230 VOLTS			460/575 VOLTS		
	High	Medium	Low	High	Medium	Low	High	Medium	Low
3 and 4 Ton Standard Efficiency (Downflow)						KGB036S and KGB048S			
0.0	1873	1561	1123	2094	1783	1321	2064	1727	1216
0.1	1993	1601	1148	2168	1797	1338	2105	1744	1229
0.2	1913	1601	1137	2098	1803	1308	2050	1694	1198
0.3	1858	1527	1078	2036	1725	1261	1987	1638	1167
0.4	1801	1496	1046	1973	1679	1219	1905	1598	1148
0.5	1763	1467	987	1910	1647	1177	1862	1559	1108
0.6	1709	1414	897	1830	1560	1080	1781	1509	1057
0.7	1617	1368	806	1727	1519	986	1698	1449	982
0.8	1472	1269	730	1604	1419	918	1614	1389	920
0.9	1359	1162	487	1478	1363	706	1488	1346	792
1.0	961	922	370	1093	1083	590	1167	1099	703
3 and 4 Ton Standard Efficiency (Horizontal)						KGB036S and KGB048S			
0.0	1799	1530	1073	2012	1747	1263	2015	1756	1251
0.1	1868	1544	1088	2032	1733	1268	2071	1760	1279
0.2	1802	1494	1068	1976	1682	1228	2014	1700	1226
0.3	1735	1432	1014	1900	1618	1185	1937	1634	1187
0.4	1666	1397	980	1825	1568	1142	1878	1597	1174
0.5	1615	1350	904	1750	1516	1078	1801	1558	1124
0.6	1564	1305	842	1675	1440	1014	1743	1479	1060
0.7	1462	1228	758	1562	1364	928	1664	1415	982
0.8	1330	1151	670	1449	1287	842	1512	1335	865
0.9	1194	1011	464	1298	1185	671	1393	1297	733
1.0	878	878	355	998	1032	565	1060	1063	618

BLOWER DATA**DIRECT DRIVE PSC - 5 TON****KGB060S4D****BLOWER TABLE INCLUDES RESISTANCE FOR BASE UNIT ONLY WITH DRY INDOOR COIL AND AIR FILTERS IN PLACE.**

FOR ALL UNITS ADD:

1 - Any factory installed options air resistance (larger gas heat section, economizer, wet coil, etc.) See page 29.

2 - Any field installed accessories air resistance (duct resistance, diffuser, etc.) See page 30.

External Static Pressure (in. w.g.)	Air Volume (cfm) at Various Blower Speeds					
	208 VOLTS		230 VOLTS		460/575 VOLTS	
	High	Low	High	Low	High	Low
5 Ton Standard Efficiency (Downflow)						KGB060S
0.0	1940	1581	2131	1788	2131	1788
0.1	1929	1566	2107	1784	2107	1784
0.2	1906	1552	2074	1774	2074	1774
0.3	1872	1546	2036	1752	2036	1752
0.4	1836	1526	1998	1708	1998	1708
0.5	1802	1486	1960	1679	1960	1679
0.6	1749	1447	1904	1635	1904	1635
0.7	1714	1407	1847	1576	1847	1576
0.8	1644	1347	1771	1518	1771	1518
0.9	1574	1245	1658	1430	1658	1430
1.0	1338	---	1506	---	1506	---
5 Ton Standard Efficiency (Horizontal)						KGB060S
0.0	1930	1575	2143	1764	2143	1764
0.1	1920	1573	2115	1761	2115	1761
0.2	1910	1576	2088	1751	2088	1751
0.3	1870	1552	2055	1746	2055	1746
0.4	1840	1524	2023	1704	2023	1704
0.5	1790	1495	1979	1675	1979	1675
0.6	1739	1466	1925	1633	1925	1633
0.7	1679	1428	1860	1590	1860	1590
0.8	1639	1371	1775	1534	1775	1534
0.9	1559	1270	1670	1421	1670	1421
1.0	1438	---	1539	1285	1539	1285

BLOWER

BELT DRIVE (SINGLE SPEED) - 3 TON

KGB036S4B

BLOWER TABLE INCLUDES RESISTANCE FOR BASE UNIT ONLY WITH DRY INDOOR COIL AND AIR FILTERS IN PLACE.

FOR ALL UNITS ADD:

1 - Any factory installed options air resistance (heat section, economizer, wet coil, etc.).

2 - Any field installed accessories air resistance (duct resistance, diffuser, etc.).

See page 29 for blower motors and drives and wet coil and options/accessory air resistance data.

DOWNFLOW

Air Volume cfm	External Static - in. w.g.															
	0.10		0.20		0.30		0.40		0.50		0.60		0.70		0.80	
	RPM	BHP	RPM	BHP	RPM	BHP	RPM	BHP	RPM	BHP	RPM	BHP	RPM	BHP	RPM	BHP
900	493	0.11	564	0.15	637	0.19	711	0.22	783	0.24	851	0.26	910	0.29	961	0.32
1000	517	0.14	588	0.18	660	0.22	733	0.24	804	0.26	868	0.29	924	0.32	974	0.35
1100	544	0.17	614	0.21	685	0.25	757	0.27	826	0.29	887	0.32	940	0.36	987	0.38
1200	574	0.2	643	0.24	712	0.28	782	0.31	849	0.33	906	0.36	956	0.39	1001	0.42
1300	613	0.23	679	0.28	745	0.31	811	0.34	873	0.36	926	0.40	973	0.43	1016	0.46
1400	662	0.26	722	0.30	781	0.34	841	0.37	897	0.41	944	0.44	989	0.48	1032	0.51
1500	710	0.29	763	0.33	816	0.38	869	0.41	919	0.45	963	0.49	1006	0.53	1049	0.56

Air Volume cfm	External Static - in. w.g.															
	0.90		1.00		1.10		1.20		1.30		1.40		1.50		1.60	
	RPM	BHP	RPM	BHP	RPM	BHP	RPM	BHP	RPM	BHP	RPM	BHP	RPM	BHP	RPM	BHP
900	1008	0.34	1056	0.36	1104	0.39	1149	0.41	1190	0.44	1229	0.46	1267	0.49	1305	0.52
1000	1020	0.37	1067	0.40	1115	0.42	1159	0.45	1200	0.48	1239	0.51	1277	0.54	1314	0.57
1100	1032	0.41	1078	0.43	1124	0.46	1168	0.49	1210	0.52	1249	0.55	1286	0.58	1323	0.62
1200	1045	0.45	1090	0.47	1135	0.50	1178	0.53	1220	0.57	1259	0.60	1296	0.64	1332	0.67
1300	1060	0.49	1104	0.51	1148	0.55	1190	0.58	1230	0.62	1269	0.65	1306	0.69	1342	0.72
1400	1075	0.53	1119	0.56	1162	0.60	1203	0.63	1242	0.67	1280	0.71	1317	0.75	1352	0.78
1500	1093	0.58	1136	0.61	1177	0.65	1217	0.69	1255	0.73	1292	0.77	1328	0.80	1364	0.84

HORIZONTAL

Air Volume cfm	External Static - in. w.g.															
	0.10		0.20		0.30		0.40		0.50		0.60		0.70		0.80	
	RPM	BHP	RPM	BHP	RPM	BHP	RPM	BHP	RPM	BHP	RPM	BHP	RPM	BHP	RPM	BHP
900	465	0.09	531	0.14	600	0.17	670	0.20	740	0.22	808	0.24	869	0.27	925	0.30
1000	483	0.12	549	0.16	617	0.20	687	0.22	756	0.24	822	0.26	881	0.29	935	0.33
1100	504	0.14	570	0.19	637	0.22	706	0.25	773	0.27	837	0.29	894	0.32	946	0.36
1200	527	0.17	592	0.22	658	0.25	726	0.28	792	0.30	854	0.32	908	0.36	957	0.39
1300	552	0.20	617	0.25	682	0.29	748	0.31	812	0.33	871	0.36	923	0.40	970	0.43
1400	580	0.24	644	0.28	708	0.32	773	0.35	834	0.37	890	0.40	938	0.44	984	0.48
1500	611	0.28	674	0.32	736	0.35	799	0.38	857	0.41	908	0.44	954	0.49	998	0.52

Air Volume cfm	External Static - in. w.g.															
	0.90		1.00		1.10		1.20		1.30		1.40		1.50		1.60	
	RPM	BHP	RPM	BHP	RPM	BHP	RPM	BHP	RPM	BHP	RPM	BHP	RPM	BHP	RPM	BHP
900	977	0.33	1028	0.36	1079	0.39	1127	0.42	1169	0.45	1208	0.48	1246	0.51	1282	0.54
1000	985	0.36	1036	0.39	1087	0.42	1135	0.45	1177	0.48	1216	0.52	1253	0.55	1290	0.58
1100	995	0.39	1044	0.42	1093	0.45	1140	0.49	1183	0.52	1223	0.56	1261	0.59	1297	0.62
1200	1005	0.43	1053	0.46	1100	0.49	1146	0.53	1190	0.56	1230	0.60	1268	0.63	1304	0.67
1300	1016	0.47	1063	0.50	1109	0.53	1154	0.57	1197	0.61	1237	0.64	1275	0.68	1311	0.72
1400	1029	0.51	1074	0.54	1120	0.58	1164	0.61	1205	0.65	1245	0.69	1282	0.73	1318	0.77
1500	1042	0.56	1087	0.59	1132	0.62	1174	0.66	1215	0.71	1253	0.75	1290	0.78	1326	0.82

BLOWER DATA

BELT DRIVE (SINGLE SPEED) - 4 TON

KGB048S4B

BLOWER TABLE INCLUDES RESISTANCE FOR BASE UNIT ONLY WITH DRY INDOOR COIL AND AIR FILTERS IN PLACE.

FOR ALL UNITS ADD:

1 - Any factory installed options air resistance (heat section, economizer, wet coil, etc.).

2 - Any field installed accessories air resistance (duct resistance, diffuser, etc.).

See page 29 for blower motors and drives and wet coil and options/accessory air resistance data.

DOWNFLOW

Air Volume cfm	External Static - in. w.g.															
	0.10		0.20		0.30		0.40		0.50		0.60		0.70		0.80	
	RPM	BHP	RPM	BHP	RPM	BHP	RPM	BHP	RPM	BHP	RPM	BHP	RPM	BHP	RPM	BHP
1200	574	0.20	644	0.24	713	0.28	784	0.31	850	0.33	906	0.36	953	0.39	998	0.42
1300	608	0.24	677	0.28	744	0.31	813	0.34	874	0.37	925	0.40	969	0.43	1014	0.46
1400	645	0.28	712	0.31	778	0.35	842	0.38	898	0.41	944	0.44	986	0.48	1030	0.51
1500	684	0.31	749	0.35	811	0.38	871	0.42	921	0.45	963	0.49	1004	0.53	1048	0.56
1600	723	0.35	785	0.39	844	0.43	898	0.46	943	0.50	983	0.54	1024	0.58	1067	0.61
1700	761	0.40	819	0.44	875	0.48	924	0.52	965	0.56	1004	0.60	1045	0.63	1089	0.66
1800	798	0.45	853	0.49	905	0.54	950	0.58	990	0.62	1028	0.66	1069	0.69	1112	0.72
1900	834	0.51	885	0.55	934	0.60	977	0.64	1015	0.68	1054	0.72	1095	0.75	1137	0.79
2000	869	0.57	917	0.62	962	0.67	1004	0.71	1042	0.75	1081	0.78	1121	0.82	1162	0.86

Air Volume cfm	External Static - in. w.g.															
	0.90		1.00		1.10		1.20		1.30		1.40		1.50		1.60	
	RPM	BHP	RPM	BHP	RPM	BHP	RPM	BHP	RPM	BHP	RPM	BHP	RPM	BHP	RPM	BHP
1200	1043	0.44	1090	0.47	1135	0.50	1179	0.53	1220	0.57	1259	0.60	1297	0.64	1333	0.67
1300	1058	0.49	1104	0.51	1148	0.55	1190	0.58	1231	0.62	1269	0.65	1306	0.69	1342	0.72
1400	1074	0.53	1119	0.56	1162	0.59	1203	0.63	1242	0.67	1280	0.71	1317	0.74	1352	0.78
1500	1092	0.58	1136	0.61	1177	0.65	1217	0.69	1255	0.73	1292	0.76	1328	0.80	1364	0.84
1600	1112	0.63	1154	0.67	1193	0.71	1232	0.75	1269	0.79	1306	0.83	1341	0.87	1377	0.91
1700	1132	0.69	1173	0.73	1211	0.77	1248	0.81	1285	0.86	1321	0.90	1356	0.94	1391	0.98
1800	1154	0.76	1194	0.80	1230	0.85	1266	0.89	1302	0.93	1338	0.98	1373	1.02	1408	1.06
1900	1178	0.83	1215	0.88	1250	0.93	1286	0.98	1321	1.02	1356	1.06	1391	1.10	1426	1.14
2000	1201	0.91	1237	0.97	1271	1.02	1307	1.07	1342	1.11	1376	1.15	1411	1.19	1446	1.23

HORIZONTAL

Air Volume cfm	External Static - in. w.g.															
	0.10		0.20		0.30		0.40		0.50		0.60		0.70		0.80	
	RPM	BHP	RPM	BHP	RPM	BHP	RPM	BHP	RPM	BHP	RPM	BHP	RPM	BHP	RPM	BHP
1200	540	0.18	606	0.22	673	0.26	748	0.29	816	0.30	870	0.33	914	0.37	961	0.40
1300	568	0.21	634	0.26	699	0.29	771	0.32	835	0.34	886	0.37	929	0.41	975	0.44
1400	599	0.25	664	0.29	728	0.33	795	0.35	855	0.38	903	0.41	946	0.45	991	0.49
1500	632	0.29	696	0.33	758	0.36	821	0.39	877	0.42	922	0.46	963	0.50	1008	0.54
1600	667	0.33	729	0.36	789	0.40	848	0.43	898	0.46	941	0.51	982	0.55	1026	0.59
1700	702	0.36	761	0.40	819	0.44	873	0.48	920	0.52	960	0.56	1001	0.61	1044	0.64
1800	737	0.41	794	0.45	848	0.49	898	0.53	941	0.58	981	0.62	1021	0.66	1064	0.70
1900	771	0.46	825	0.50	877	0.54	923	0.59	964	0.64	1002	0.68	1043	0.72	1085	0.76
2000	805	0.51	857	0.56	905	0.61	948	0.66	987	0.71	1025	0.75	1065	0.79	1107	0.82

Air Volume cfm	External Static - in. w.g.															
	0.90		1.00		1.10		1.20		1.30		1.40		1.50		1.60	
	RPM	BHP	RPM	BHP	RPM	BHP	RPM	BHP	RPM	BHP	RPM	BHP	RPM	BHP	RPM	BHP
1200	1010	0.43	1061	0.46	1110	0.50	1156	0.53	1199	0.57	1239	0.61	1276	0.64	1312	0.68
1300	1024	0.47	1073	0.50	1120	0.54	1165	0.58	1207	0.62	1246	0.65	1284	0.69	1320	0.73
1400	1038	0.52	1086	0.55	1131	0.59	1175	0.62	1216	0.66	1255	0.70	1292	0.74	1328	0.78
1500	1054	0.57	1100	0.60	1144	0.64	1186	0.68	1226	0.72	1264	0.75	1301	0.79	1336	0.83
1600	1071	0.62	1116	0.65	1158	0.69	1198	0.73	1237	0.77	1274	0.81	1310	0.85	1345	0.89
1700	1089	0.67	1132	0.71	1172	0.75	1211	0.79	1249	0.83	1285	0.87	1321	0.91	1355	0.95
1800	1108	0.73	1149	0.77	1188	0.81	1225	0.85	1262	0.90	1298	0.94	1332	0.98	1366	1.01
1900	1128	0.79	1167	0.84	1204	0.88	1241	0.92	1276	0.97	1311	1.01	1345	1.05	1379	1.09
2000	1148	0.86	1186	0.91	1221	0.96	1257	1.00	1292	1.05	1326	1.09	1359	1.13	1393	1.17

BLOWER DATA

BELT DRIVE (SINGLE SPEED) - 5 TON

KGB060S4B

BLOWER TABLE INCLUDES RESISTANCE FOR BASE UNIT ONLY WITH DRY INDOOR COIL AND AIR FILTERS IN PLACE.

FOR ALL UNITS ADD:

1 - Any factory installed options air resistance (heat section, economizer, wet coil, etc.).

2 - Any field installed accessories air resistance (duct resistance, diffuser, etc.).

See page 29 for blower motors and drives and wet coil and options/accessory air resistance data.

DOWNFLOW

Air Volume cfm	External Static - in. w.g.															
	0.10		0.20		0.30		0.40		0.50		0.60		0.70		0.80	
	RPM	BHP	RPM	BHP	RPM	BHP	RPM	BHP	RPM	BHP	RPM	BHP	RPM	BHP	RPM	BHP
1600	720	0.28	769	0.33	819	0.37	871	0.41	926	0.44	975	0.47	1016	0.51	1054	0.55
1700	779	0.30	822	0.35	864	0.39	908	0.44	953	0.48	995	0.52	1034	0.57	1072	0.61
1800	828	0.34	864	0.39	901	0.43	938	0.48	977	0.53	1015	0.58	1053	0.63	1091	0.67
1900	858	0.41	892	0.45	927	0.50	962	0.55	999	0.60	1036	0.65	1074	0.69	1112	0.73
2000	879	0.47	913	0.52	948	0.56	984	0.61	1020	0.67	1058	0.72	1096	0.76	1134	0.80
2100	900	0.53	935	0.58	970	0.63	1007	0.69	1044	0.74	1081	0.79	1119	0.84	1157	0.88
2200	922	0.60	958	0.65	994	0.71	1031	0.76	1068	0.82	1106	0.87	1143	0.91	1180	0.95
2300	947	0.67	983	0.73	1020	0.79	1057	0.85	1094	0.90	1131	0.95	1168	1.00	1205	1.03
2400	974	0.76	1010	0.82	1047	0.88	1084	0.94	1120	0.99	1157	1.04	1193	1.08	1230	1.12

Air Volume cfm	External Static - in. w.g.															
	0.90		1.00		1.10		1.20		1.30		1.40		1.50		1.60	
	RPM	BHP	RPM	BHP	RPM	BHP	RPM	BHP	RPM	BHP	RPM	BHP	RPM	BHP	RPM	BHP
1600	1093	0.60	1133	0.63	1173	0.67	1214	0.70	1253	0.73	1288	0.77	1318	0.81	1351	0.85
1700	1111	0.65	1150	0.69	1190	0.72	1230	0.76	1268	0.79	1301	0.83	1331	0.87	1363	0.92
1800	1130	0.71	1169	0.75	1208	0.78	1247	0.82	1285	0.86	1317	0.90	1345	0.94	1377	0.98
1900	1150	0.77	1188	0.81	1227	0.85	1267	0.88	1303	0.92	1333	0.97	1361	1.02	1392	1.06
2000	1172	0.84	1210	0.88	1248	0.92	1286	0.96	1321	1.00	1350	1.05	1377	1.10	1409	1.14
2100	1195	0.91	1233	0.95	1269	1.00	1306	1.04	1339	1.09	1367	1.14	1395	1.19	1426	1.23
2200	1218	0.99	1255	1.03	1290	1.09	1324	1.14	1356	1.19	1385	1.24	1413	1.28	1444	1.32
2300	1242	1.07	1277	1.13	1310	1.20	1343	1.26	1374	1.30	1403	1.34	1432	1.38	1464	1.42
2400	1267	1.16	1300	1.23	1332	1.31	1364	1.37	1394	1.41	1423	1.45	1453	1.48	1484	1.53

HORIZONTAL

Air Volume cfm	External Static - in. w.g.															
	0.10		0.20		0.30		0.40		0.50		0.60		0.70		0.80	
	RPM	BHP	RPM	BHP	RPM	BHP	RPM	BHP	RPM	BHP	RPM	BHP	RPM	BHP	RPM	BHP
1600	654	0.28	712	0.32	769	0.36	825	0.39	879	0.43	933	0.47	982	0.50	1024	0.54
1700	703	0.31	756	0.35	807	0.39	858	0.43	906	0.47	955	0.51	999	0.55	1039	0.59
1800	752	0.34	798	0.38	844	0.43	889	0.48	933	0.52	977	0.57	1017	0.61	1056	0.65
1900	796	0.38	837	0.43	878	0.48	918	0.53	958	0.58	997	0.62	1036	0.67	1074	0.71
2000	833	0.43	870	0.48	907	0.54	943	0.59	980	0.64	1018	0.69	1055	0.73	1093	0.77
2100	864	0.50	897	0.55	931	0.60	966	0.65	1002	0.71	1038	0.76	1075	0.80	1113	0.83
2200	887	0.57	920	0.62	953	0.67	988	0.73	1024	0.78	1060	0.83	1097	0.87	1135	0.90
2300	909	0.64	942	0.70	976	0.75	1011	0.81	1046	0.86	1083	0.91	1120	0.95	1157	0.98
2400	931	0.72	965	0.78	999	0.83	1035	0.89	1071	0.94	1108	0.99	1144	1.03	1181	1.07

Air Volume cfm	External Static - in. w.g.															
	0.90		1.00		1.10		1.20		1.30		1.40		1.50		1.60	
	RPM	BHP	RPM	BHP	RPM	BHP	RPM	BHP	RPM	BHP	RPM	BHP	RPM	BHP	RPM	BHP
1600	1063	0.58	1101	0.61	1141	0.64	1181	0.67	1222	0.70	1261	0.73	1298	0.77	1333	0.81
1700	1078	0.63	1117	0.66	1156	0.69	1196	0.72	1235	0.75	1273	0.79	1309	0.83	1344	0.87
1800	1094	0.68	1133	0.72	1172	0.75	1211	0.78	1250	0.81	1287	0.85	1322	0.90	1355	0.94
1900	1112	0.74	1151	0.77	1190	0.81	1228	0.84	1265	0.88	1301	0.92	1335	0.97	1367	1.01
2000	1131	0.80	1170	0.83	1208	0.87	1245	0.91	1281	0.96	1316	1.00	1349	1.04	1380	1.09
2100	1151	0.87	1189	0.90	1227	0.94	1263	0.99	1298	1.04	1331	1.08	1363	1.13	1394	1.17
2200	1173	0.94	1210	0.98	1246	1.02	1281	1.07	1315	1.12	1347	1.17	1379	1.22	1409	1.26
2300	1195	1.02	1231	1.06	1266	1.11	1300	1.16	1333	1.22	1364	1.27	1395	1.32	1424	1.36
2400	1217	1.10	1252	1.15	1286	1.20	1319	1.26	1351	1.32	1382	1.38	1411	1.43	1440	1.48

BLOWER DATA

BELT DRIVE (SINGLE AND TWO-SPEED - 6 TON (DOWNFLOW))

KGB074S4B | KGB074S4T

BLOWER TABLE INCLUDES RESISTANCE FOR BASE UNIT ONLY WITH DRY INDOOR COIL AND AIR FILTERS IN PLACE.

FOR ALL UNITS ADD:

1 - Any factory installed options air resistance (heat section, economizer, wet coil, etc.).

2 - Any field installed accessories air resistance (duct resistance, diffuser, etc.).

See page 29 for blower motors and drives and wet coil and options/accessory air resistance data.

Air Volume cfm	External Static - in. w.g.															
	0.10		0.20		0.30		0.40		0.50		0.60		0.70		0.80	
	RPM	BHP	RPM	BHP	RPM	BHP	RPM	BHP	RPM	BHP	RPM	BHP	RPM	BHP	RPM	BHP
1900	857	0.41	892	0.45	927	0.50	962	0.55	999	0.60	1036	0.65	1074	0.69	1112	0.73
2000	879	0.47	913	0.52	948	0.56	984	0.61	1020	0.67	1058	0.72	1096	0.76	1134	0.80
2100	900	0.53	935	0.58	970	0.63	1007	0.69	1044	0.74	1081	0.79	1119	0.84	1157	0.88
2200	922	0.60	958	0.65	994	0.71	1031	0.76	1068	0.82	1106	0.87	1143	0.91	1180	0.95
2300	947	0.67	983	0.73	1020	0.79	1057	0.85	1094	0.90	1131	0.95	1168	1.00	1205	1.03
2400	974	0.76	1010	0.82	1047	0.88	1084	0.94	1120	0.99	1157	1.04	1193	1.08	1230	1.12
2500	1002	0.85	1039	0.91	1075	0.97	1112	1.03	1148	1.08	1184	1.13	1220	1.17	1257	1.21
2600	1032	0.95	1068	1.01	1105	1.07	1141	1.13	1177	1.17	1213	1.22	1248	1.26	1284	1.31
2700	1062	1.05	1099	1.11	1136	1.17	1172	1.22	1207	1.27	1242	1.32	1277	1.37	1312	1.43
2800	1094	1.16	1131	1.22	1167	1.27	1202	1.32	1237	1.38	1271	1.43	1305	1.49	1339	1.56
2900	1127	1.26	1163	1.32	1198	1.38	1233	1.44	1267	1.50	1300	1.56	1334	1.64	1367	1.71

Air Volume cfm	External Static - in. w.g.															
	0.90		1.00		1.10		1.20		1.30		1.40		1.50		1.60	
	RPM	BHP	RPM	BHP	RPM	BHP	RPM	BHP	RPM	BHP	RPM	BHP	RPM	BHP	RPM	BHP
1900	1150	0.77	1188	0.81	1227	0.85	1267	0.88	1303	0.92	1333	0.97	1360	1.02	1392	1.06
2000	1172	0.84	1210	0.88	1248	0.92	1286	0.96	1321	1.00	1350	1.05	1377	1.10	1409	1.14
2100	1195	0.91	1233	0.95	1269	1.00	1306	1.04	1339	1.09	1367	1.14	1395	1.19	1426	1.23
2200	1218	0.99	1255	1.03	1290	1.09	1324	1.14	1356	1.19	1385	1.24	1413	1.28	1444	1.32
2300	1242	1.07	1277	1.13	1310	1.20	1343	1.26	1374	1.30	1403	1.34	1432	1.38	1464	1.42
2400	1267	1.16	1300	1.23	1332	1.31	1364	1.37	1394	1.41	1423	1.45	1453	1.48	1484	1.53
2500	1292	1.26	1324	1.34	1355	1.42	1387	1.48	1417	1.52	1445	1.56	1475	1.59	1506	1.64
2600	1318	1.38	1350	1.46	1380	1.55	1411	1.60	1440	1.64	1469	1.68	1498	1.71	1529	1.76
2700	1345	1.51	1376	1.60	1406	1.68	1436	1.73	1465	1.77	1493	1.80	1523	1.84	1553	1.88
2800	1372	1.65	1403	1.74	1433	1.82	1462	1.86	1490	1.90	1519	1.93	1548	1.97	1578	2.01
2900	1399	1.80	1430	1.89	1460	1.96	1489	2.00	1516	2.03	1544	2.06	1573	2.10	1603	2.14

BLOWER DATA

BELT DRIVE (SINGLE AND TWO-SPEED) - 6 TON (HORIZONTAL)

KGB074S4B | KGB074S4T

BLOWER TABLE INCLUDES RESISTANCE FOR BASE UNIT ONLY WITH DRY INDOOR COIL AND AIR FILTERS IN PLACE.

FOR ALL UNITS ADD:

1 - Any factory installed options air resistance (heat section, economizer, wet coil, etc.).

2 - Any field installed accessories air resistance (duct resistance, diffuser, etc.).

See page 29 for blower motors and drives and wet coil and options/accessory air resistance data.

Air Volume cfm	External Static - in. w.g.															
	0.10		0.20		0.30		0.40		0.50		0.60		0.70		0.80	
	RPM	BHP	RPM	BHP	RPM	BHP	RPM	BHP	RPM	BHP	RPM	BHP	RPM	BHP	RPM	BHP
1900	796	0.38	837	0.43	878	0.48	918	0.53	958	0.58	997	0.62	1036	0.67	1074	0.71
2000	833	0.43	870	0.48	907	0.54	943	0.59	980	0.64	1018	0.69	1055	0.73	1093	0.77
2100	864	0.50	897	0.55	931	0.60	966	0.65	1002	0.71	1038	0.76	1075	0.80	1113	0.83
2200	887	0.57	920	0.62	953	0.67	988	0.73	1024	0.78	1060	0.83	1097	0.87	1135	0.90
2300	909	0.64	942	0.70	976	0.75	1011	0.81	1046	0.86	1083	0.91	1120	0.95	1157	0.98
2400	931	0.72	965	0.78	999	0.83	1035	0.89	1071	0.94	1108	0.99	1144	1.03	1181	1.07
2500	955	0.80	989	0.86	1024	0.92	1061	0.98	1097	1.03	1133	1.08	1170	1.11	1205	1.15
2600	981	0.90	1016	0.96	1052	1.01	1088	1.07	1124	1.12	1160	1.16	1195	1.20	1230	1.25
2700	1009	0.99	1044	1.05	1080	1.11	1116	1.16	1152	1.21	1187	1.26	1221	1.30	1254	1.35
2800	1038	1.10	1073	1.16	1109	1.21	1145	1.26	1180	1.31	1214	1.36	1247	1.40	1279	1.46
2900	1068	1.20	1104	1.26	1139	1.31	1174	1.36	1208	1.41	1240	1.47	1273	1.52	1304	1.58

Air Volume cfm	External Static - in. w.g.															
	0.90		1.00		1.10		1.20		1.30		1.40		1.50		1.60	
	RPM	BHP	RPM	BHP	RPM	BHP	RPM	BHP	RPM	BHP	RPM	BHP	RPM	BHP	RPM	BHP
1900	1112	0.74	1151	0.77	1190	0.81	1228	0.84	1265	0.88	1301	0.92	1335	0.97	1367	1.01
2000	1131	0.80	1170	0.83	1208	0.87	1245	0.91	1281	0.96	1316	1.00	1349	1.04	1380	1.09
2100	1151	0.87	1189	0.90	1227	0.94	1263	0.99	1298	1.04	1331	1.08	1363	1.13	1394	1.17
2200	1173	0.94	1210	0.98	1246	1.02	1281	1.07	1315	1.12	1347	1.17	1379	1.22	1409	1.26
2300	1195	1.02	1231	1.06	1266	1.11	1300	1.16	1333	1.22	1364	1.27	1395	1.32	1424	1.36
2400	1217	1.10	1252	1.15	1286	1.20	1319	1.26	1351	1.32	1382	1.38	1411	1.43	1440	1.48
2500	1240	1.20	1274	1.25	1307	1.31	1339	1.37	1370	1.43	1400	1.49	1428	1.55	1457	1.59
2600	1264	1.30	1297	1.35	1329	1.42	1360	1.49	1389	1.55	1418	1.61	1446	1.67	1475	1.72
2700	1287	1.40	1319	1.47	1350	1.54	1380	1.61	1409	1.68	1437	1.74	1465	1.79	1493	1.84
2800	1311	1.52	1342	1.59	1373	1.66	1402	1.74	1430	1.8	1457	1.87	1485	1.92	1513	1.97
2900	1335	1.65	1366	1.72	1395	1.79	1424	1.87	1451	1.94	1478	2.00	1505	2.05	1533	2.09

BLOWER DATA

BELT DRIVE (SINGLE AND TWO-SPEED) - 6 TON (DOWNFLOW)

KGB072H4B | KGB074H4T

BLOWER TABLE INCLUDES RESISTANCE FOR BASE UNIT ONLY WITH DRY INDOOR COIL AND AIR FILTERS IN PLACE.

FOR ALL UNITS ADD:

1 - Any factory installed options air resistance (heat section, economizer, etc.).

2 - Any field installed accessories air resistance (duct resistance, diffuser, etc.).

See page 29 for blower motors and drives and wet coil and options/accessory air resistance data.

Air Volume (cfm)	External Static (in.w.g.)																			
	0.10		0.20		0.30		0.40		0.50		0.60		0.70		0.80		0.9		1.0	
	RPM	BHP	RPM	BHP	RPM	BHP	RPM	BHP	RPM	BHP	RPM	BHP	RPM	BHP	RPM	BHP	RPM	BHP	RPM	BHP
1900	523	0.47	557	0.53	591	0.59	625	0.64	660	0.68	694	0.72	730	0.76	764	0.8	796	0.84	824	0.89
2000	540	0.51	574	0.57	608	0.63	643	0.68	677	0.72	710	0.76	745	0.8	777	0.84	807	0.89	834	0.94
2100	559	0.56	592	0.61	626	0.67	660	0.72	694	0.77	727	0.81	760	0.85	790	0.89	819	0.94	844	1
2200	578	0.6	611	0.66	645	0.71	678	0.76	711	0.81	743	0.86	775	0.9	804	0.95	830	1	855	1.06
2300	599	0.65	632	0.71	664	0.76	697	0.81	729	0.86	760	0.91	790	0.96	817	1.01	842	1.07	867	1.12
2400	621	0.71	652	0.76	684	0.81	716	0.86	746	0.92	776	0.97	805	1.02	830	1.08	855	1.14	879	1.19
2500	642	0.77	673	0.82	704	0.87	734	0.93	764	0.98	793	1.04	820	1.09	845	1.15	868	1.21	892	1.27
2600	665	0.82	694	0.88	724	0.93	753	0.99	782	1.05	810	1.11	835	1.17	859	1.23	883	1.29	907	1.34
2700	688	0.89	716	0.94	744	1	773	1.06	800	1.13	827	1.19	851	1.25	875	1.31	898	1.37	922	1.42
2800	710	0.95	738	1.02	765	1.08	792	1.15	818	1.21	844	1.28	868	1.34	891	1.4	914	1.45	938	1.51
2900	733	1.03	759	1.1	785	1.17	811	1.24	836	1.3	861	1.37	885	1.43	908	1.49	931	1.54	954	1.59

Air Volume (cfm)	External Static (in.w.g.)																			
	1.1		1.2		1.3		1.4		1.5		1.6		1.7		1.8		1.9		2.0	
	RPM	BHP	RPM	BHP	RPM	BHP	RPM	BHP	RPM	BHP	RPM	BHP	RPM	BHP	RPM	BHP	RPM	BHP	RPM	BHP
1900	851	0.94	878	0.98	904	1.03	930	1.07	957	1.11	984	1.15	1010	1.2	1035	1.25	1060	1.31	1084	1.37
2000	860	0.99	886	1.04	913	1.08	939	1.12	966	1.17	992	1.21	1018	1.26	1043	1.32	1067	1.38	1090	1.43
2100	870	1.05	896	1.1	922	1.14	948	1.18	975	1.23	1001	1.27	1027	1.33	1051	1.39	1074	1.44	1097	1.5
2200	880	1.11	906	1.16	932	1.2	959	1.25	985	1.29	1011	1.34	1036	1.4	1059	1.46	1082	1.52	1105	1.58
2300	891	1.18	917	1.22	943	1.27	970	1.31	996	1.36	1021	1.41	1046	1.47	1068	1.53	1090	1.6	1113	1.66
2400	904	1.25	929	1.29	956	1.34	982	1.39	1008	1.43	1032	1.49	1056	1.55	1078	1.62	1099	1.68	1121	1.75
2500	917	1.32	942	1.37	968	1.41	994	1.46	1020	1.51	1044	1.57	1066	1.64	1088	1.7	1108	1.77	1130	1.84
2600	931	1.39	957	1.44	982	1.49	1008	1.54	1032	1.6	1055	1.66	1077	1.73	1098	1.8	1118	1.87	1139	1.94
2700	946	1.47	971	1.52	996	1.57	1021	1.63	1045	1.69	1067	1.76	1088	1.83	1108	1.91	1127	1.98	1148	2.05
2800	962	1.56	986	1.61	1011	1.66	1034	1.72	1057	1.79	1079	1.86	1099	1.94	1118	2.02	1137	2.09	1158	2.16
2900	978	1.65	1001	1.7	1025	1.75	1048	1.82	1069	1.89	1090	1.98	1109	2.06	1128	2.14	1147	2.22	1167	2.28

BLOWER DATA

BELT DRIVE (SINGLE AND TWO-SPEED) - 6 TON (HORIZONTAL)

KGB072H4B | KGB074H4T

BLOWER TABLE INCLUDES RESISTANCE FOR BASE UNIT ONLY WITH DRY INDOOR COIL AND AIR FILTERS IN PLACE.

FOR ALL UNITS ADD:

- 1 - Any factory installed options air resistance (heat section, economizer, etc.).
- 2 - Any field installed accessories air resistance (duct resistance, diffuser, etc.).

See page 29 for blower motors and drives and wet coil and options/accessory air resistance data.

Air Volume (cfm)	External Static (in.w.g.)																			
	0.10		0.20		0.30		0.40		0.50		0.60		0.70		0.80		0.9		1.0	
	RPM	BHP	RPM	BHP	RPM	BHP	RPM	BHP	RPM	BHP	RPM	BHP	RPM	BHP	RPM	BHP	RPM	BHP	RPM	BHP
1900	490	0.5	521	0.53	554	0.56	588	0.6	622	0.63	656	0.67	690	0.71	725	0.75	759	0.79	790	0.83
2000	505	0.55	537	0.58	569	0.61	602	0.64	636	0.68	669	0.71	702	0.75	736	0.79	769	0.84	798	0.88
2100	521	0.6	552	0.62	584	0.66	617	0.69	650	0.73	682	0.76	715	0.8	747	0.84	778	0.89	807	0.93
2200	537	0.65	569	0.68	600	0.71	632	0.74	665	0.78	696	0.81	728	0.85	759	0.9	789	0.94	816	0.99
2300	554	0.7	585	0.73	617	0.76	648	0.79	680	0.83	711	0.87	741	0.91	771	0.95	799	1	826	1.05
2400	572	0.75	602	0.78	633	0.81	664	0.85	695	0.88	725	0.92	755	0.97	784	1.01	811	1.06	836	1.11
2500	591	0.8	620	0.83	650	0.87	680	0.9	711	0.94	740	0.98	769	1.03	797	1.08	823	1.13	847	1.18
2600	610	0.86	639	0.89	668	0.92	697	0.96	727	1	755	1.05	783	1.09	810	1.14	835	1.2	859	1.25
2700	630	0.91	658	0.95	686	0.98	715	1.02	743	1.07	771	1.11	798	1.16	824	1.22	848	1.27	872	1.32
2800	650	0.97	677	1.01	705	1.05	732	1.09	760	1.14	787	1.19	813	1.24	838	1.3	861	1.35	885	1.4
2900	670	1.03	697	1.07	724	1.11	750	1.16	777	1.21	803	1.27	828	1.32	852	1.38	876	1.44	898	1.49

Air Volume (cfm)	External Static (in.w.g.)																			
	1.1		1.2		1.3		1.4		1.5		1.6		1.7		1.8		1.9		2.0	
	RPM	BHP	RPM	BHP	RPM	BHP	RPM	BHP	RPM	BHP	RPM	BHP	RPM	BHP	RPM	BHP	RPM	BHP	RPM	BHP
1900	818	0.88	843	0.92	869	0.97	896	1.01	924	1.05	953	1.1	981	1.14	1008	1.19	1034	1.24	1059	1.29
2000	825	0.93	850	0.97	875	1.02	902	1.06	930	1.11	958	1.15	986	1.2	1012	1.25	1038	1.3	1061	1.35
2100	833	0.98	857	1.03	883	1.07	910	1.12	937	1.16	965	1.21	991	1.26	1017	1.31	1041	1.37	1064	1.42
2200	841	1.04	866	1.09	891	1.13	918	1.18	945	1.22	972	1.27	998	1.32	1022	1.38	1045	1.44	1067	1.49
2300	851	1.1	875	1.15	901	1.19	927	1.24	954	1.29	980	1.34	1004	1.39	1028	1.45	1050	1.51	1071	1.57
2400	861	1.16	886	1.21	911	1.26	937	1.3	963	1.35	988	1.41	1012	1.47	1034	1.53	1055	1.59	1076	1.65
2500	872	1.23	896	1.27	921	1.32	947	1.37	972	1.43	997	1.48	1019	1.55	1041	1.61	1061	1.68	1081	1.74
2600	883	1.3	908	1.35	933	1.4	958	1.45	982	1.5	1006	1.57	1027	1.63	1048	1.7	1068	1.77	1087	1.83
2700	895	1.37	920	1.42	944	1.47	969	1.53	992	1.59	1015	1.65	1036	1.72	1056	1.79	1075	1.86	1094	1.92
2800	908	1.45	932	1.5	956	1.56	980	1.62	1003	1.68	1025	1.75	1045	1.82	1064	1.89	1083	1.96	1102	2.02
2900	922	1.54	945	1.59	969	1.65	992	1.71	1014	1.78	1035	1.85	1055	1.92	1074	2	1092	2.07	1111	2.13

BLOWER DATA

BELT DRIVE (SINGLE AND TWO-SPEED) - 7.5 TON (DOWNFLOW)

KGB090S4B | KGB090S4T

BLOWER TABLE INCLUDES RESISTANCE FOR BASE UNIT ONLY WITH DRY INDOOR COIL AND AIR FILTERS IN PLACE.

FOR ALL UNITS ADD:

1 - Any factory installed options air resistance (heat section, economizer, etc.).

2 - Any field installed accessories air resistance (duct resistance, diffuser, etc.).

See page 29 for blower motors and drives and wet coil and options/accessory air resistance data.

Air Volume (cfm)	External Static (in.w.g.)																			
	0.10		0.20		0.30		0.40		0.50		0.60		0.70		0.80		0.9		1.0	
	RPM	BHP	RPM	BHP	RPM	BHP	RPM	BHP	RPM	BHP	RPM	BHP	RPM	BHP	RPM	BHP	RPM	BHP	RPM	BHP
2400	621	0.71	652	0.76	684	0.81	716	0.86	746	0.92	776	0.97	805	1.02	830	1.08	855	1.14	879	1.19
2500	642	0.77	673	0.82	704	0.87	734	0.93	764	0.98	793	1.04	820	1.09	845	1.15	868	1.21	892	1.27
2600	665	0.82	694	0.88	724	0.93	753	0.99	782	1.05	810	1.11	835	1.17	859	1.23	883	1.29	907	1.34
2700	688	0.89	716	0.94	744	1.00	773	1.06	800	1.13	827	1.19	851	1.25	875	1.31	898	1.37	922	1.42
2800	710	0.95	738	1.02	765	1.08	792	1.15	818	1.21	844	1.28	868	1.34	891	1.40	914	1.45	938	1.51
2900	733	1.03	759	1.10	785	1.17	811	1.24	836	1.30	861	1.37	885	1.43	908	1.49	931	1.54	954	1.59
3000	754	1.12	779	1.19	805	1.26	830	1.33	855	1.40	879	1.46	902	1.52	925	1.58	948	1.63	970	1.69
3100	775	1.22	800	1.29	824	1.36	849	1.43	873	1.50	897	1.56	920	1.62	942	1.67	964	1.73	987	1.78
3200	796	1.32	820	1.39	844	1.47	868	1.53	892	1.60	915	1.66	937	1.72	959	1.77	981	1.83	1002	1.88
3300	816	1.43	840	1.50	863	1.57	887	1.64	910	1.70	933	1.76	955	1.82	976	1.88	997	1.93	1018	1.99
3400	837	1.54	860	1.61	883	1.68	906	1.75	929	1.81	951	1.87	972	1.93	993	1.98	1013	2.05	1033	2.11
3500	858	1.66	881	1.73	903	1.79	926	1.86	948	1.92	969	1.98	990	2.04	1009	2.10	1029	2.17	1048	2.24
3600	879	1.77	901	1.84	923	1.91	945	1.97	966	2.04	987	2.10	1006	2.16	1025	2.23	1044	2.30	1062	2.38

Air Volume (cfm)	External Static (in.w.g.)																			
	1.1		1.2		1.3		1.4		1.5		1.6		1.7		1.8		1.9		2.0	
	RPM	BHP	RPM	BHP	RPM	BHP	RPM	BHP	RPM	BHP	RPM	BHP	RPM	BHP	RPM	BHP	RPM	BHP	RPM	BHP
2400	904	1.25	929	1.29	956	1.34	982	1.39	1008	1.43	1032	1.49	1056	1.55	1078	1.62	1099	1.68	1121	1.75
2500	917	1.32	942	1.37	968	1.41	994	1.46	1020	1.51	1044	1.57	1066	1.64	1088	1.70	1108	1.77	1130	1.84
2600	931	1.39	957	1.44	982	1.49	1008	1.54	1032	1.60	1055	1.66	1077	1.73	1098	1.80	1118	1.87	1139	1.94
2700	946	1.47	971	1.52	996	1.57	1021	1.63	1045	1.69	1067	1.76	1088	1.83	1108	1.91	1127	1.98	1148	2.05
2800	962	1.56	986	1.61	1011	1.66	1034	1.72	1057	1.79	1079	1.86	1099	1.94	1118	2.02	1137	2.09	1158	2.16
2900	978	1.65	1001	1.70	1025	1.75	1048	1.82	1069	1.89	1090	1.98	1109	2.06	1128	2.14	1147	2.22	1167	2.28
3000	993	1.74	1016	1.79	1039	1.86	1061	1.93	1081	2.01	1101	2.10	1120	2.18	1138	2.27	1157	2.34	1177	2.41
3100	1009	1.84	1031	1.90	1052	1.97	1073	2.05	1093	2.13	1112	2.22	1130	2.31	1148	2.40	1167	2.47	1187	2.53
3200	1024	1.94	1045	2.01	1065	2.09	1085	2.17	1104	2.26	1123	2.36	1141	2.45	1159	2.53	1178	2.60	1198	2.66
3300	1038	2.06	1058	2.13	1078	2.22	1097	2.31	1116	2.40	1134	2.49	1152	2.58	1170	2.66	1189	2.73	1209	2.79
3400	1053	2.19	1072	2.27	1091	2.35	1109	2.45	1127	2.54	1145	2.63	1163	2.72	1181	2.79	1200	2.86	1220	2.92
3500	1067	2.32	1085	2.41	1103	2.50	1121	2.59	1138	2.69	1156	2.78	1174	2.85	1192	2.93	1212	2.99	1231	3.05
3600	1081	2.46	1098	2.55	1116	2.64	1133	2.74	1151	2.83	1168	2.91	1186	2.99	1205	3.06	1224	3.12	1243	3.17

BLOWER DATA BELT DRIVE (SINGLE AND TWO-SPEED) - 7.5 TON (HORIZONTAL)

KGB090S4B | KGB090S4T

BLOWER TABLE INCLUDES RESISTANCE FOR BASE UNIT ONLY WITH DRY INDOOR COIL AND AIR FILTERS IN PLACE.

FOR ALL UNITS ADD:

- 1 - Any factory installed options air resistance (heat section, economizer, etc.).
- 2 - Any field installed accessories air resistance (duct resistance, diffuser, etc.).

See page 29 for blower motors and drives and wet coil and options/accessory air resistance data.

Air Volume (cfm)	External Static (in.w.g.)																			
	0.10		0.20		0.30		0.40		0.50		0.60		0.70		0.80		0.9		1.0	
	RPM	BHP	RPM	BHP	RPM	BHP	RPM	BHP	RPM	BHP	RPM	BHP	RPM	BHP	RPM	BHP	RPM	BHP	RPM	BHP
2400	572	0.75	602	0.78	633	0.81	664	0.85	695	0.88	725	0.92	755	0.97	784	1.01	811	1.06	836	1.11
2500	591	0.80	620	0.83	650	0.87	680	0.90	711	0.94	740	0.98	769	1.03	797	1.08	823	1.13	847	1.18
2600	610	0.86	639	0.89	668	0.92	697	0.96	727	1.00	755	1.05	783	1.09	810	1.14	835	1.20	859	1.25
2700	630	0.91	658	0.95	686	0.98	715	1.02	743	1.07	771	1.11	798	1.16	824	1.22	848	1.27	872	1.32
2800	650	0.97	677	1.01	705	1.05	732	1.09	760	1.14	787	1.19	813	1.24	838	1.30	861	1.35	885	1.40
2900	670	1.03	697	1.07	724	1.11	750	1.16	777	1.21	803	1.27	828	1.32	852	1.38	876	1.44	898	1.49
3000	691	1.09	717	1.14	743	1.18	769	1.24	794	1.29	819	1.35	844	1.42	868	1.47	890	1.53	913	1.58
3100	712	1.16	737	1.21	762	1.27	787	1.32	812	1.39	836	1.45	860	1.51	883	1.57	906	1.63	928	1.68
3200	732	1.24	756	1.30	781	1.36	805	1.42	829	1.48	853	1.55	876	1.61	899	1.67	921	1.73	943	1.78
3300	752	1.33	776	1.39	799	1.46	823	1.52	847	1.59	870	1.65	893	1.71	916	1.77	937	1.83	959	1.88
3400	772	1.43	795	1.50	818	1.56	842	1.63	865	1.69	888	1.76	910	1.82	932	1.88	953	1.93	974	1.99
3500	792	1.54	815	1.61	838	1.67	861	1.74	883	1.80	906	1.87	928	1.93	949	1.98	970	2.04	990	2.10
3600	812	1.65	834	1.72	857	1.79	880	1.85	902	1.92	924	1.98	945	2.04	966	2.10	986	2.16	1005	2.22

Air Volume (cfm)	External Static (in.w.g.)																			
	1.1		1.2		1.3		1.4		1.5		1.6		1.7		1.8		1.9		2.0	
	RPM	BHP	RPM	BHP	RPM	BHP	RPM	BHP	RPM	BHP	RPM	BHP	RPM	BHP	RPM	BHP	RPM	BHP	RPM	BHP
2400	861	1.16	886	1.21	911	1.26	937	1.30	963	1.35	988	1.41	1012	1.47	1034	1.53	1055	1.59	1076	1.65
2500	872	1.23	896	1.27	921	1.32	947	1.37	972	1.43	997	1.48	1019	1.55	1041	1.61	1061	1.68	1081	1.74
2600	883	1.30	908	1.35	933	1.40	958	1.45	982	1.50	1006	1.57	1027	1.63	1048	1.70	1068	1.77	1087	1.83
2700	895	1.37	920	1.42	944	1.47	969	1.53	992	1.59	1015	1.65	1036	1.72	1056	1.79	1075	1.86	1094	1.92
2800	908	1.45	932	1.50	956	1.56	980	1.62	1003	1.68	1025	1.75	1045	1.82	1064	1.89	1083	1.96	1102	2.02
2900	922	1.54	945	1.59	969	1.65	992	1.71	1014	1.78	1035	1.85	1055	1.92	1074	2.00	1092	2.07	1111	2.13
3000	936	1.63	959	1.68	982	1.74	1004	1.81	1026	1.88	1046	1.96	1065	2.03	1084	2.11	1102	2.18	1120	2.25
3100	950	1.73	973	1.78	995	1.85	1017	1.91	1037	1.99	1057	2.07	1076	2.15	1094	2.23	1112	2.31	1130	2.38
3200	965	1.83	987	1.89	1008	1.95	1029	2.03	1049	2.11	1068	2.19	1087	2.28	1105	2.36	1123	2.44	1141	2.51
3300	980	1.94	1001	2.00	1022	2.07	1042	2.15	1061	2.23	1080	2.32	1098	2.41	1116	2.50	1134	2.58	1152	2.65
3400	995	2.05	1015	2.12	1035	2.19	1054	2.28	1073	2.37	1092	2.46	1110	2.55	1128	2.64	1145	2.72	1163	2.79
3500	1010	2.17	1029	2.24	1048	2.32	1067	2.41	1086	2.51	1104	2.60	1122	2.70	1139	2.78	1157	2.86	1174	2.93
3600	1024	2.30	1043	2.38	1062	2.46	1080	2.55	1098	2.65	1116	2.75	1133	2.84	1151	2.93	1168	3.01	1186	3.08

BLOWER DATA

BELT DRIVE KIT SPECIFICATIONS - 036-074S

Model No.	Motor HP		No. of Speeds	Drive Kits and RPM Range							
	Nominal	Maximum		A01	A02	A03	A04	A05	A06	A07	A08
036	1	1.15	1	673-1010	---	---	---	897-1346	---	---	---
	2	2.3	1	673-1010	---	---	---	897-1346	---	---	---
048	1	1.15	1	---	745-1117	---	---	---	1071-1429	---	---
	2	2.3	1	---	745-1117	---	---	---	1071-1429	---	---
060	1	1.15	1	---	---	833-1250	---	---	---	1212-1548	---
	2	2.3	1	---	---	833-1250	---	---	---	1212-1548	---
074S	1	1.5	2	---	---	---	968-1340	---	---	---	1193-1591
	2	2.3	2	---	---	---	968-1340	---	---	---	1193-1591

BELT DRIVE KIT SPECIFICATIONS - 072H/074H/090S

Model No.	Motor HP		No. of Speeds	Drive Kits and RPM Range			
	Nominal	Maximum		AA01	AA02	AA03	AA04
072H	1	1.15	1	522-784	632-875	798-1105	---
	2	2.3	1	522-784	632-875	798-1105	---
074H	1	1.15	2	522-784	632-875	798-1105	---
	2	2.3	2	522-784	632-875	798-1105	---
090S4B	1	1.15	1	522-784	632-875	798-1105	---
	2	2.3	1	522-784	632-875	798-1105	---
	3	3.45	1	522-784	632-875	798-1105	921-1228
090S4T	2	2.3	2	522-784	632-875	798-1105	---

NOTE - Using total air volume and system static pressure requirements determine from blower performance tables rpm and motor hp required. Maximum usable hp of motors furnished are shown. In Canada, nominal motor hp is also maximum usable motor hp. If motors of comparable hp are used, be sure to keep within the service factor limitations outlined on the motor nameplate.

OPTIONS / ACCESSORIES AIR RESISTANCE FOR 024-074 MODELS - in. w.g.

Air Volume cfm	Wet Indoor Coil			Humiditrol Coil		Gas Heat		Economizer	Filters	
	024-048	060	072/074	024-048	060, 074	Medium Input	High Input		MERV 8	MERV 13
800	0.01	0.01	0.01	0.00	0.00	0.02	0.02	0.04	0.04	0.05
1000	0.02	0.02	0.01	0.00	0.00	0.02	0.02	0.04	0.04	0.07
1200	0.03	0.04	0.02	0.01	0.00	0.02	0.02	0.04	0.04	0.07
1400	0.04	0.05	0.03	0.02	0.01	0.02	0.03	0.04	0.04	0.07
1600	0.05	0.06	0.04	0.03	0.02	0.03	0.04	0.04	0.04	0.07
1800	0.06	0.07	0.05	0.04	0.02	0.03	0.05	0.05	0.05	0.07
2000	0.08	0.09	0.06	0.04	0.03	0.04	0.06	0.05	0.05	0.08
2200	0.09	0.10	0.07	---	0.04	0.04	0.07	0.05	0.05	0.08
2400	0.10	0.12	0.08	---	0.04	0.05	0.08	0.05	0.05	0.08
2600	0.11	0.13	0.09	---	0.05	0.05	0.09	0.06	0.05	0.08
2800	0.13	0.15	0.10	---	0.05	0.06	0.10	0.06	0.05	0.08
3000	0.14	0.16	0.12	---	0.06	0.07	0.11	0.06	0.05	0.08

OPTIONS / ACCESSORIES AIR RESISTANCE FOR 090 MODELS - in. w.g.

Air Volume cfm	Wet Indoor Coil	Humiditrol Coil	Gas Heat		Economizer	Filters	
			High Input			MERV 8	MERV 13
2400	0.08	0.04	0.03		0.05	0.05	0.08
2600	0.09	0.05	0.04		0.06	0.05	0.08
2800	0.10	0.05	0.04		0.06	0.05	0.08
3000	0.11	0.06	0.04		0.06	0.05	0.08
3200	0.12	0.06	0.04		0.06	0.06	0.09
3400	0.14	0.07	0.05		0.06	0.06	0.09
3600	0.15	0.07	0.05		0.06	0.06	0.10

BLOWER DATA

CEILING DIFFUSERS AIR RESISTANCE (in. w.g.)

Air Volume cfm	RTD9-65S Step-Down Diffuser			FD9-65S Flush Diffuser	RTD11-95S Step-Down Diffuser			FD11-95S Flush Diffuser
	2 Ends Open	1 Side & 2 Ends Open	All Ends & Sides Open		2 Ends Open	1 Side & 2 Ends Open	All Ends & Sides Open	
800	0.15	0.13	0.11	0.11	---	---	---	---
1000	0.19	0.16	0.14	0.14	---	---	---	---
1200	0.25	0.20	0.17	0.17	---	---	---	---
1400	0.33	0.26	0.20	0.20	---	---	---	---
1600	0.43	0.32	0.20	0.24	---	---	---	---
1800	0.56	0.40	0.30	0.30	0.13	0.11	0.09	0.09
2000	0.73	0.50	0.36	0.36	0.15	0.13	0.11	0.10
2200	0.95	0.63	0.44	0.44	0.18	0.15	0.12	0.12
2400	---	----	---	---	0.21	0.18	0.15	0.14
2600	---	----	---	---	0.24	0.21	0.18	0.17
2800	---	----	---	---	0.27	0.24	0.21	0.20
3000	---	----	---	---	0.32	0.29	0.25	0.25
3200	---	----	---	---	0.41	0.37	0.32	0.31
3400	---	----	---	---	0.50	0.45	0.39	0.37
3600	---	----	---	---	0.61	0.54	0.48	0.44

CEILING DIFFUSER AIR THROW DATA

Air Volume - cfm	¹ Effective Throw - ft.	
	Model No.	RTD9-65S
800	10 - 17	14 - 18
1000	10 - 17	15 - 20
1200	11 - 18	16 - 22
1400	12 - 19	17 - 24
1600	12 - 20	18 - 25
1800	13 - 21	20 - 28
2000	14 - 23	21 - 29
2200	16 - 25	22 - 30
Model No.	RTD11-95S	FD11-95S
2600	24 - 29	19 - 24
2800	25 - 30	20 - 28
3000	27 - 33	21 - 29
3200	28 - 35	22 - 29
3400	30 - 37	22 - 30
3600	25 - 33	22 - 24

¹ Effective throw based on terminal velocities of 75 ft. per minute.

POWER EXHAUST FAN PERFORMANCE

Return Air System Static Pressure - in. w.g.	Air Volume Exhausted cfm
0.00	2000
0.05	1990
0.10	1924
0.15	1810
0.20	1664
0.25	1507
0.30	1350
0.35	1210

ELECTRICAL DATA		DIRECT DRIVE ECM - 2 TON 2.5 TON ECM	
Model No.		KGB024S4E	KGB030S4E
¹ Voltage - 60hz		208/230V - 1 Ph	208/230V - 1 Ph
Compressor	Rated Load Amps	10.9	13.5
	Locked Rotor Amps	60	73
Outdoor Fan Motor	Full Load Amps	1.7	1.7
Service Outlet 115V GFI (amps)		15	15
Indoor Blower Motor	Horsepower	0.33	0.33
	Type	Direct (ECM)	Direct (ECM)
	Full Load Amps	2.9	2.9
² Maximum Overcurrent Protection	Unit Only	25	30
³ Minimum Circuit Ampacity	Unit Only	19	22
ELECTRICAL ACCESSORIES			
Disconnect	Standard Access	20W17	20W17
	Hinged Access	20W23	20W23

NOTE - All units have a minimum Short Circuit Current Rating (SCCR) of 5000 amps.

¹ Extremes of operating range are plus and minus 10% of line voltage.

² HACR type breaker or fuse.

³ Refer to National or Canadian Electrical Code manual to determine wire, fuse and disconnect size requirements.

ELECTRICAL DATA		DIRECT DRIVE ECM - 3 TON 4 TON 5 TON		
Model No.		KGB036S4E	KGB048S4E	KGB060S4E
¹ Voltage - 60hz		208/230V - 1 Ph	208/230V - 1 Ph	208/230V - 1 Ph
Compressor	Rated Load Amps	15.3	20	24.4
	Locked Rotor Amps	70	99	144
Outdoor Fan Motor	Full Load Amps	1.7	1.7	1.65
Power Exhaust (1) 0.33 HP	Full Load Amps	2.4	2.4	2.4
Service Outlet 115V GFI (amps)		15	15	15
Indoor Blower Motor	Horsepower	0.50	0.75	1.0
	Type	Direct (ECM)	Direct (ECM)	Direct (ECM)
	Full Load Amps	4.6	6.3	8.4
² Maximum Overcurrent Protection	Unit Only	40	50	60
	with (1) 0.33 HP Power Exhaust	40	50	60
³ Minimum Circuit Ampacity	Unit Only	26	33	41
	with (1) 0.33 HP Power Exhaust	28	36	43
ELECTRICAL ACCESSORIES				
Disconnect	Standard Access	20W17	20W17	20W20
	Hinged Access	20W23	20W23	20W26

NOTE - All units have a minimum Short Circuit Current Rating (SCCR) of 5000 amps.

¹ Extremes of operating range are plus and minus 10% of line voltage.

² HACR type breaker or fuse.

³ Refer to National or Canadian Electrical Code manual to determine wire, fuse and disconnect size requirements.

ELECTRICAL DATA**DIRECT DRIVE PSC - 3 TON**

Model No.		KGB036S4D		
		208/230V - 3 Ph	460V - 3 Ph	575V - 3 Ph
¹ Voltage - 60hz				
Compressor	Rated Load Amps	8.7	4	3.6
	Locked Rotor Amps	70	31	27
Outdoor Fan Motor	Full Load Amps	1.7	1.1	0.7
Power Exhaust (1) 0.33 HP	Full Load Amps	2.4	1.3	1
Service Outlet 115V GFI (amps)		15	15	20
Indoor Blower Motor	Horsepower	0.5	0.5	0.5
	Type	Direct (PSC)	Direct (PSC)	Direct (PSC)
	Full Load Amps	3.9	2	2
² Maximum Overcurrent Protection	Unit Only	25	15	15
	with (1) 0.33 HP Power Exhaust	25	15	15
³ Minimum Circuit Ampacity	Unit Only	17	9	8
	with (1) 0.33 HP Power Exhaust	19	10	9

ELECTRICAL ACCESSORIES

Disconnect	Standard Access	20W17	20W17	20W17
	Hinged Access	20W23	20W23	20W23

NOTE - All units have a minimum Short Circuit Current Rating (SCCR) of 5000 amps.

¹ Extremes of operating range are plus and minus 10% of line voltage.² HACR type breaker or fuse.³ Refer to National or Canadian Electrical Code manual to determine wire, fuse and disconnect size requirements.**ELECTRICAL DATA****DIRECT DRIVE PSC - 4 TON****KGB048S4D - STANDARD EFFICIENCY - DIRECT DRIVE PSC BLOWER**

		208/230V - 3 Ph	460V - 3 Ph	575V - 3 Ph
¹ Voltage - 60hz				
Compressor	Rated Load Amps	11	5.5	4.7
	Locked Rotor Amps	86	37	34
Outdoor Fan Motor	Full Load Amps	1.7	1.1	0.7
Power Exhaust (1) 0.33 HP	Full Load Amps	2.4	1.3	1
Service Outlet 115V GFI (amps)		15	1.3	1
Indoor Blower Motor	Horsepower	0.5	0.5	0.5
	Type	Direct (PSC)	Direct (PSC)	Direct (PSC)
	Full Load Amps	3.9	2	2
² Maximum Overcurrent Protection	Unit Only	30	15	15
	with (1) 0.33 HP Power Exhaust	30	15	15
³ Minimum Circuit Ampacity	Unit Only	20	10	9
	with (1) 0.33 HP Power Exhaust	22	12	10

ELECTRICAL ACCESSORIES

Disconnect	Standard Access	20W17	20W17	20W17
	Hinged Access	20W23	20W23	20W23

NOTE - All units have a minimum Short Circuit Current Rating (SCCR) of 5000 amps.

¹ Extremes of operating range are plus and minus 10% of line voltage.² HACR type breaker or fuse.³ Refer to National or Canadian Electrical Code manual to determine wire, fuse and disconnect size requirements.

ELECTRICAL DATA**DIRECT DRIVE PSC - 5 TON**

Model No.		KGB060S4D		
		208/230V - 3 Ph	460V - 3 Ph	575V - 3 Ph
¹ Voltage - 60hz				
Compressor	Rated Load Amps	16	7.8	5.7
	Locked Rotor Amps	110	52	38.9
Outdoor Fan Motor	Full Load Amps	1.65	0.8	1
Power Exhaust (1) 0.33 HP	Full Load Amps	2.4	1.3	1
Service Outlet 115V GFI (amps)		15	15	20
Indoor Blower Motor	Horsepower	0.75	0.75	0.75
	Type	Direct (PSC)	Direct (PSC)	Direct (PSC)
	Full Load Amps	4.9	2.5	2.5
² Maximum Overcurrent Protection	Unit Only	40	20	15
	with (1) 0.33 HP Power Exhaust	40	20	15
³ Minimum Circuit Ampacity	Unit Only	27	14	10
	with (1) 0.33 HP Power Exhaust	29	15	12

ELECTRICAL ACCESSORIES

Disconnect	Standard Access	20W20	20W20	20W20
	Hinged Access	20W26	20W26	20W26

NOTE - All units have a minimum Short Circuit Current Rating (SCCR) of 5000 amps.

¹ Extremes of operating range are plus and minus 10% of line voltage.

² HACR type breaker or fuse.

³ Refer to National or Canadian Electrical Code manual to determine wire, fuse and disconnect size requirements.

KGB PARTS ARRANGEMENT

FILTERS (4)

024, 030, 036, 048 16 X 20 X 2"
060, 072, 090: 20 X 20 X 2"

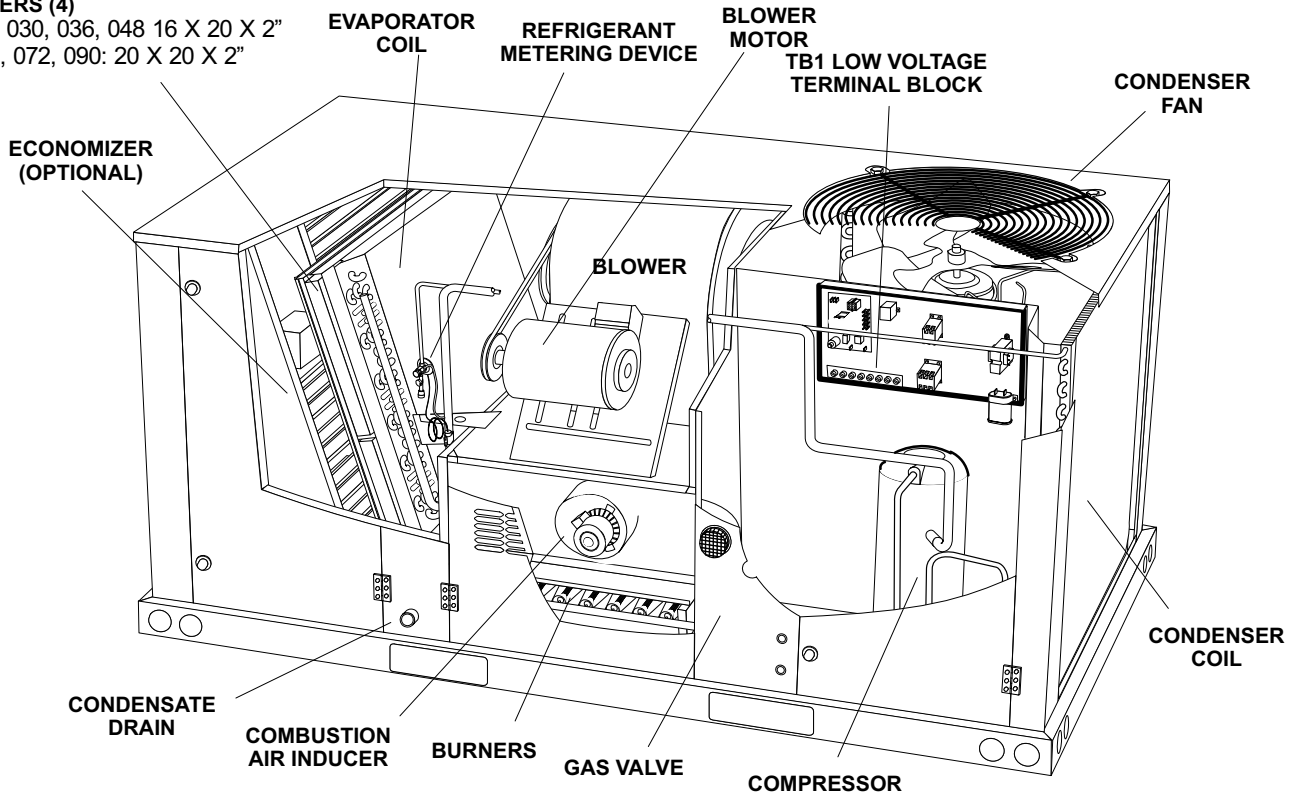

FIGURE 1

KGB CONTROL BOX

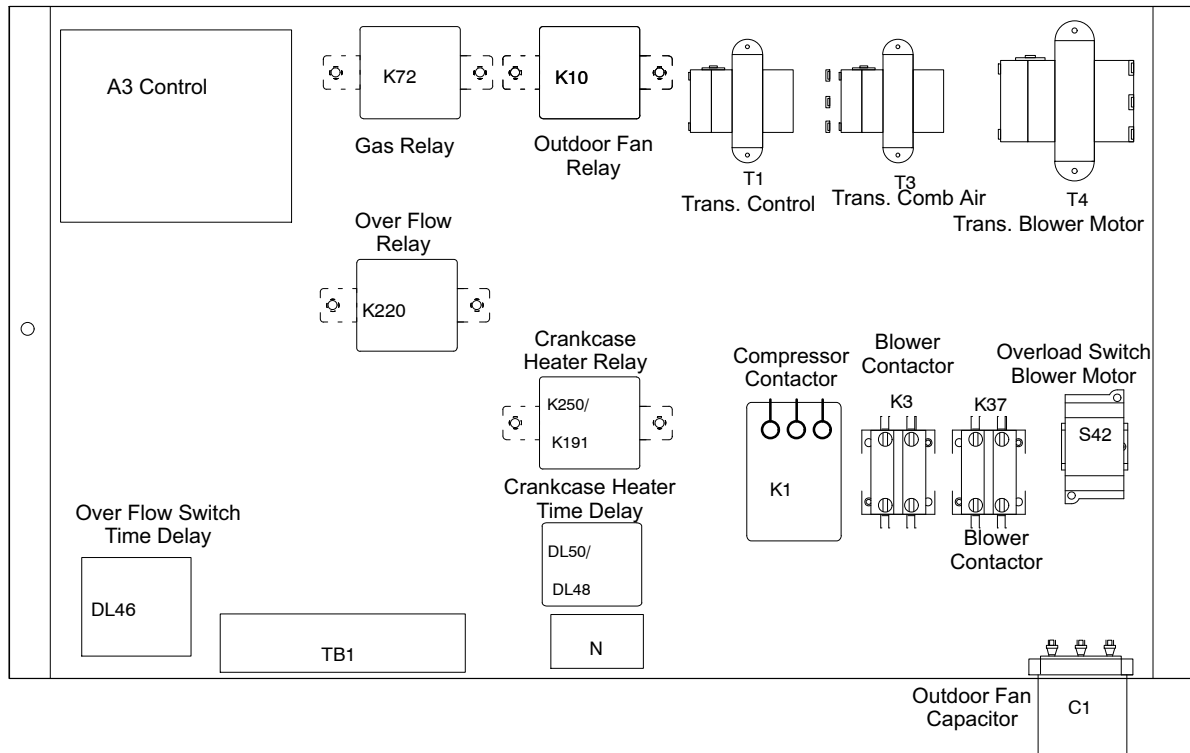

FIGURE 2

I-UNIT COMPONENTS

All 2 through 7-1/2 ton (7 through 21 kW) units are built to order units (BTO). The KGB unit components are shown in figure 1. All units come standard with removable unit panels. All L1, L2, and L3 wiring is color coded; L1 is red, L2 is yellow, and L3 is blue.

A-Control Box Components

KGB control box components are shown in figure 2. The control box is located in the upper right portion of the compressor compartment.

1-Control Transformer T1

All use a single line voltage to 24VAC transformer mounted in the control box. Transformer supplies power to control circuits in the unit. The transformer is rated at 70VA and is protected by a 3.5 amp circuit breaker (CB8). The 208/230 (Y) voltage transformers use two

primary voltage taps as shown in figure 3, while 460 (G) and 575 (J) voltage transformers use a single primary voltage tap.

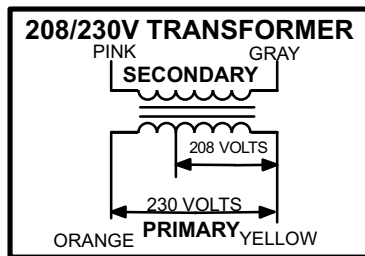

FIGURE 3

2-C. A. I. Transformers T3 (G, J voltage)

All (G) 460 and 575 (J) voltage units use transformer T3 mounted in the control box. The transformers have an output rating of 0.75A. T3 transformer supplies 230 VAC power to the combustion air inducer motor (B6).

3-Transformer T4 (J voltage)

All (J) 575 voltage direct drive units use transformer T4 mounted in the control box. T4 is a line voltage to 460V transformer to power the indoor blower. It is connected to line voltage and is powered at all times.

4-Terminal Strip TB1

All indoor thermostat connections will be to TB1 located in the control box. Thermostats without "occupied" and "unoccupied" modes and installed with economizer or motorized outdoor air equipped units, should have a jumper across terminals "R" and "OC".

5-Fan Capacitor C1 (three phase)

Fan capacitors C1 is used to assist in the start up of condenser fan B4. Ratings will be on side of capacitor or outdoor fan motor nameplate.

6-Dual Capacitor C12 (single phase)

A single dual capacitor is used for both the outdoor fan and compressor (see unit diagram). The fan side and the compressor side have different MFD ratings. See side of capacitor for ratings.

7-Compressor Contactor K1

In all KGB units, K1 energizes compressors B1 in response to thermostat demand. Three phase units use three pole double break contactors with a 24 volt coil. Single phase units use single pole double break contactors with a 24 volt coil.

8-Blower Delay DL3 &DL50 -074 Only

When second stage heat demand is satisfied DL3 causes a 180 second blower off delay.

DL50 causes a 1.5 second delay switching from high speed to low speed.

9-Relay K239 -074 Units Only

Relay K239 sends the Y1 demand "G" signal to K3 (through K250) to energize the blower on low speed and also sends the "W1" demand "G" signal to K37 (through K250) to energize the blower on high speed.

10-Relay K250 -074 Units Only

Relay K250 passes the "G" signal to contactor K3 energizing the blower on low speed. On a Y2 call K250 passes the signal to K37 energizing the blower on high speed and internal solenoid L34 energizing the compressor on high speed.

11-Blower Contactor K37 (074 only)

On two-speed operation K37 acts as the high speed blower contactor and K3 acts as the low speed contactor in response to blower demand.

12-Blower Contactor K3

On three phase units, K3 is a two pole double-break contactor with a 24VAC coil and on single phase units is a single pole double break contactor with a 24 volt coil. K3 energizes the indoor blower motor B3 in response to blower demand.

13-Condenser Fan Relay K10 (G, J voltage)

Outdoor fan relay K10 is an optional DPDT relay with a 24VAC coil. K10 energizes condenser fan B4.

14-Crankcase Heater Delay DL48 & Crankcase Heater Relay K191

Delay DL48 and relay K191 keep crankcase heater de-energized during and immediately following compressor shut down. They ensure the crankcase heater is off while compressor is energized.

15-Gas Relay K72 (two stage units)

Relay K72 is normally closed and controls combustion air inducer B6. K72 switches the inducer B6 to high speed in response to two stage heat demand.

16-Burner Control A3

⚠ WARNING	
	Shock hazard. Spark related components contain high voltage which can cause personal injury or death. Disconnect power before servicing. Control is not field repairable. Unsafe operation will result. If control is inoperable, simply replace the entire control.

The main control box (see figure 2) houses the burner control A3.

The ignition control provides four main functions: gas valve control, blower control, ignition, and flame sensing. The control has a green LED to show control status (table 1). The unit will usually ignite on the first trial and A3 allows three trials for ignition before locking out. The lockout time is 1 hour. After lockout, the ignition control automatically resets and provides three more attempts at ignition. Manual reset after lockout requires removing power from the control for more than 1 second or removing the thermostat call for heat for more than 1 second but no more than 20 seconds. 24 volt thermostat connections (P2) and heating component connections (J1) are made through separate jackplugs. See table 2 for thermostat terminations and table 3 for heating component terminations.

Flame rectification sensing is used on all units. Loss of flame during a heating cycle is indicated by an absence of flame signal (0 microamps). If this happens, the control will immediately restart the ignition sequence and then lock out if ignition is not gained after the third trial. See System Service Checks section for flame current measurement.

The control shuts off gas flow immediately in the event of a power failure. Upon restoration of gas and power, the control will restart the ignition sequence and continue until flame is established or system locks out.

TABLE 1

LED	STATUS
Slow Flash	Normal operation. No call for heat.
Fast Flash	Normal operation. Call for heat.
Steady Off	Internal Control Fault, No Power To Board or Gas Valve Relay Fault
Steady On	Control Internal Failure.
2 Flashes	Lockout. Failed to detect or sustain flame.
3 Flashes	Rollout switch open / Prove switch open or closed.
4 Flashes	Primary High Limit switch open.
5 Flashes	Flame sensed but gas valve not open.

TABLE 2

P2 TERMINAL DESIGNATIONS	
Pin #	Function
1	R 24 Volts to thermostat
2	W1 Heat Demand
3	Y Cool Demand
4	C Common
5	G Indoor Blower
6	BL OUT Indoor Blower Relay
7	W2 Second Stage Heat

TABLE 3

J1 TERMINAL DESIGNATIONS	
Pin #	Function
1	Limit Switch Out
2	Rollout Switch / Prove Switch Out
3	Gas Valve Common
4	Gas Valve Out
5	Rollout Switch / Prove Switch In
6	Limit Switch In

Operation

On a heating demand, the ignition control checks for a closed limit switch and open combustion air prove switch. Once this check is complete and conditions are correct, the ignition control then allows 30 seconds for the combustion air inducer to vent exhaust gases from the burners. When the combustion air inducer is purging the exhaust gases, the combustion air prove switch closes proving that the combustion air inducer is operating before allowing the ignition control to energize. When the combustion air prove switch is closed and the delay is over, the ignition control activates the gas valve, the spark electrode and the flame sensing electrode. Once the gas valve is energized the non-adjustable 40 second indoor blower delay period begins. Sparking stops immediately after flame is sensed or at the end of the 8 second trial for ignition.

The control then proceeds to “steady state” mode where all inputs are monitored to ensure the limit switch, rollout switch and prove switch are closed as well as flame is present. When the heat call is satisfied and the gas valve is de-energized, a combustion air inducer post purge period of 5 seconds begins along with a 120 second blower off delay.

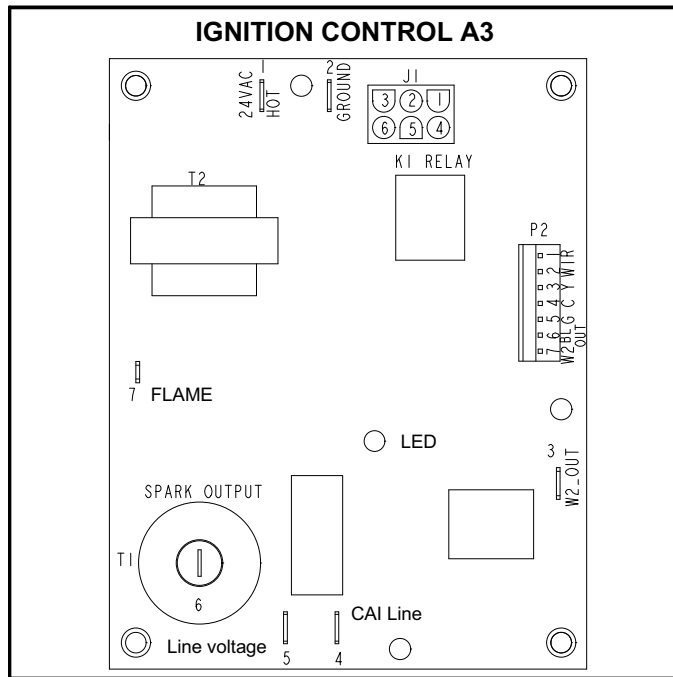

FIGURE 4

B-Cooling Components

All units use independent cooling circuits consisting of separate compressor, condenser coil and evaporator coil. See figure 5. One draw-through type condenser fan is used in KGB024/090 units. Units are equipped with belt-drive or direct drive blowers which draw air across the evaporator during unit operation.

Cooling may be supplemented by a factory- or field-installed economizer. The evaporator coil is slab type and uses a thermostatic expansion valve or fixed orifice assembly as the primary refrigerant metering device. Each evaporator is also equipped with enhanced fins and rifled tubing. In all units each compressor is protected by a freezestat (S49) on

the evaporator coil and a high pressure switch (S4) on the discharge line. See figure 5. A Low ambient switch (S11) is available as a field accessory for additional compressor protection.

1-Compressor B1

⚠ IMPORTANT

The Clean Air Act of 1990 bans the intentional venting of refrigerant (CFC's and HCFC's) as of July 1, 1992. Approved methods of recovery, recycling or reclaiming must be followed. Fines and/or incarceration may be levied for non-compliance.

All KGB024/090 units use one scroll compressor. See “SPECIFICATIONS” and “ELECTRICAL DATA” (table of contents) or compressor nameplate for compressor specifications. The KGB074 is equipped with a two-stage compressor.

⚠ WARNING

Electrical shock hazard. Compressor must be grounded. Do not operate without protective cover over terminals. Disconnect power before removing protective cover. Discharge capacitors before servicing unit. Failure to follow these precautions could cause electrical shock resulting in injury or death.

Each compressor is energized by a corresponding compressor contactor.

NOTE-Refer to the wiring diagram section for specific unit operation.

If Interlink compressor replacement is necessary, call 1-800-453-6669.

⚠ IMPORTANT

Some scroll compressors have an internal vacuum protector that will unload scrolls when suction pressure goes below 20 psig. A hissing sound will be heard when the compressor is running unloaded. Protector will reset when low pressure in system rises above 40 psig. **DO NOT REPLACE COMPRESSOR.**

KGB PLUMBING and S49 FREEZESTAT LOCATION

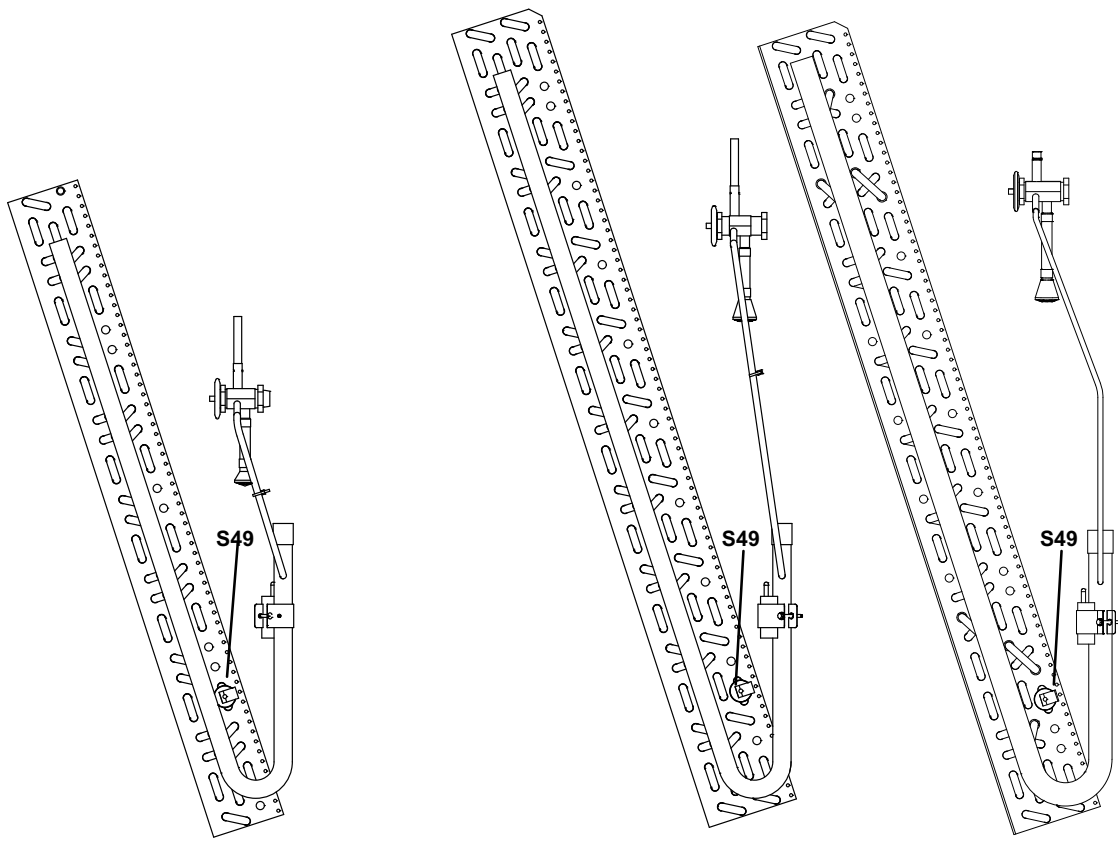
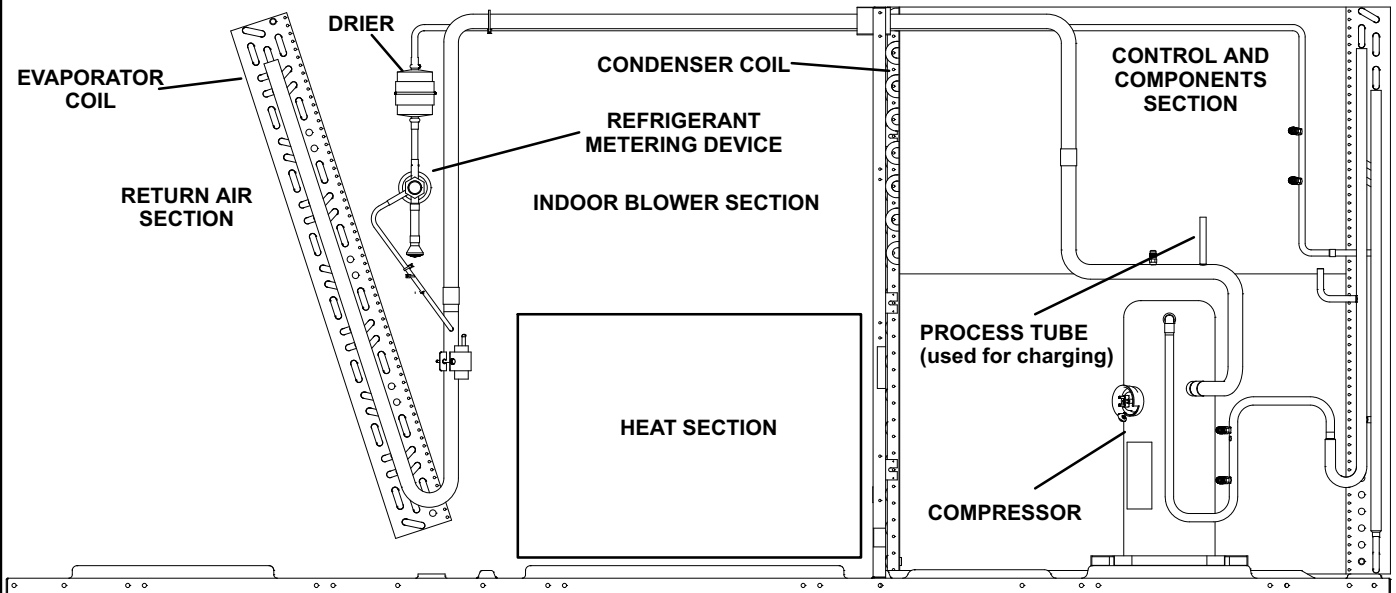

024S, 030S, 036S, 048S

072/074

060, 090

FIGURE 5

2-Freezestat S49

Each unit is equipped with a low temperature switch (freezestat) located on a return bend of each evaporator coil.

The freezestat is wired in series with the compressor contactor K1. The freezestat is a SPST N.C. auto-reset switch which opens at $29^{\circ}\text{F} \pm 3^{\circ}\text{F}$ ($-1.7^{\circ}\text{C} \pm 1.7^{\circ}\text{C}$) on a temperature drop and closes at $58^{\circ}\text{F} \pm 4^{\circ}\text{F}$ ($14.4^{\circ}\text{C} \pm 2.2^{\circ}\text{C}$) on a temperature rise. To prevent coil icing, freezestats open during compressor operation to temporarily disable the respective compressor until the coil temperature rises.

If the freezestats are tripping frequently due to coil icing, check the airflow / filters, economizer position and unit charge before allowing unit back in operation. Make sure to eliminate conditions which might promote evaporator ice buildup.

3-High Pressure Switch S4

The high pressure switch is an auto reset SPST N.C. switch which opens on a pressure rise.

S4 is located in the compressor discharge line and wired in series with the compressor contactor coil.

When discharge pressure rises to 640 ± 20 psig (4412 ± 138 kPa) (indicating a problem in the system) the switch opens and the respective compressor is de-energized (the economizer can continue to operate). When discharge pressure drops to 475 ± 30 psig (3275 ± 206 kPa), the switch closes.

4-Low Ambient Switches S11 (optional)

The low ambient switch is an auto-reset SPST N.O. pressure switch which allows for mechanical cooling operation at low outdoor temperatures. In all models the switch is located in each liquid line prior to the indoor coil section and is wired in series with outdoor fan B4. When S11 opens B4 is de-energized.

In G, J and M voltage units, S11 is wired in series with outdoor fan relay K10 coil and when opened breaks 24 volts to the coil, de-energizing outdoor fan B4.

When liquid pressure rises to 450 ± 10 psig (3102 ± 69 kPa), the switch closes and the condenser fan is energized. When discharge pressure in drops to 240 ± 10 psig (1655 ± 69 kPa), the switch opens and the condenser fan is de-energized. This intermittent fan operation results in higher evaporating temperature allowing the system to operate without icing the evaporator coil and losing capacity.

5-Low Temperature Switch S3 (optional) (compressor monitor)

S3 is a SPST bimetal thermostat which opens on tempera-

ture drop. It is wired in line with the 24VAC compressor contactor. When outdoor temperature drops below 40°F (4.5°C) the switch opens and de-energizes the compressor. When the compressor is de-energized the cooling demand is handled by the economizer. The switch automatically re-sets when outdoor temperature rises to 50°F (10°C).

C-Blower Compartment

1-Blower Wheels

All belt drive units use $10'' \times 10''$ (254 mm x 254 mm) blower wheels. The KGB024, 030, 036 and 048 direct drive units use $10'' \times 10''$ (254 mm x 254 mm) blower wheels also. The KCB060 direct drive units use $11'' \times 10''$ (279 mm x 254 mm) blower wheels. KG072/074 units use a $15'' \times 9''$ (381 mm x 228 mm) blower wheel.

2-Indoor Blower Motor Capacitor C4

All single phase blower motors are PSC and requires a run capacitor. Ratings may vary from each motor. See motor nameplate for capacitor ratings.

3-Indoor Blower Motor B3

All direct drive units use single phase PSC motors. Belt drive units use single or three phase motors (same as supply voltage). CFM adjustments on belt drive units are made by adjusting the motor pulley (sheave). CFM adjustments on direct drive units are made by changing speed taps. Motors are equipped with sealed ball bearings. All motor specifications are listed in the SPECIFICATIONS (table of contents) in the front of this manual. Units may be equipped with motors manufactured by various manufacturers, therefore electrical FLA and LRA specifications will vary. See unit rating plate for information specific to your unit.

⚠ IMPORTANT

Three phase scroll compressors must be phased sequentially for correct compressor and blower rotation. Follow "COOLING START-UP" section of installation instructions to ensure proper compressor and blower operation.

A-Blower Operation

Initiate blower demand at thermostat according to instructions provided with thermostat. Unit will cycle on thermostat demand. The following steps apply to applications using a typical electro-mechanical thermostat.

- 1- Blower operation is manually set at the thermostat sub-base fan switch. With fan switch in **ON** position, blowers will operate continuously.
- 2- With fan switch in **AUTO** position, the blowers will cycle with demand. Blowers and entire unit will be off when system switch is in **OFF** position.

B-Determining Unit CFM - Single-Speed, Direct Drive Blowers

- 1- The following measurements must be made with air filters in place.
- 2- With all access panels in place, measure static pressure external to unit (from supply to return). Add any additional air resistance for options and accessories shown in accessory air resistance tables. Blower performance data is based on static pressure readings taken in locations shown in figure 7.

Note - Static pressure readings can vary if not taken where shown.

- 3- Use figure 6 to determine the factory set blower speed.

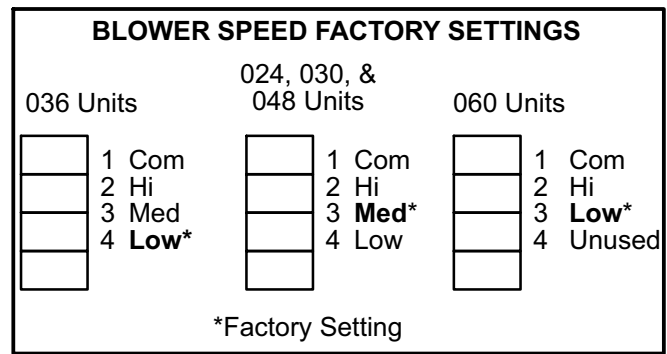

FIGURE 6

- 4- Use direct drive blower tables, the measured static pressure and the factory-set blower speed to determine CFM. If CFM is lower or higher than the design specified CFM, move the leads as shown in figure 8 for 208/230 volt units and figure 9 for 460/575 volt units.

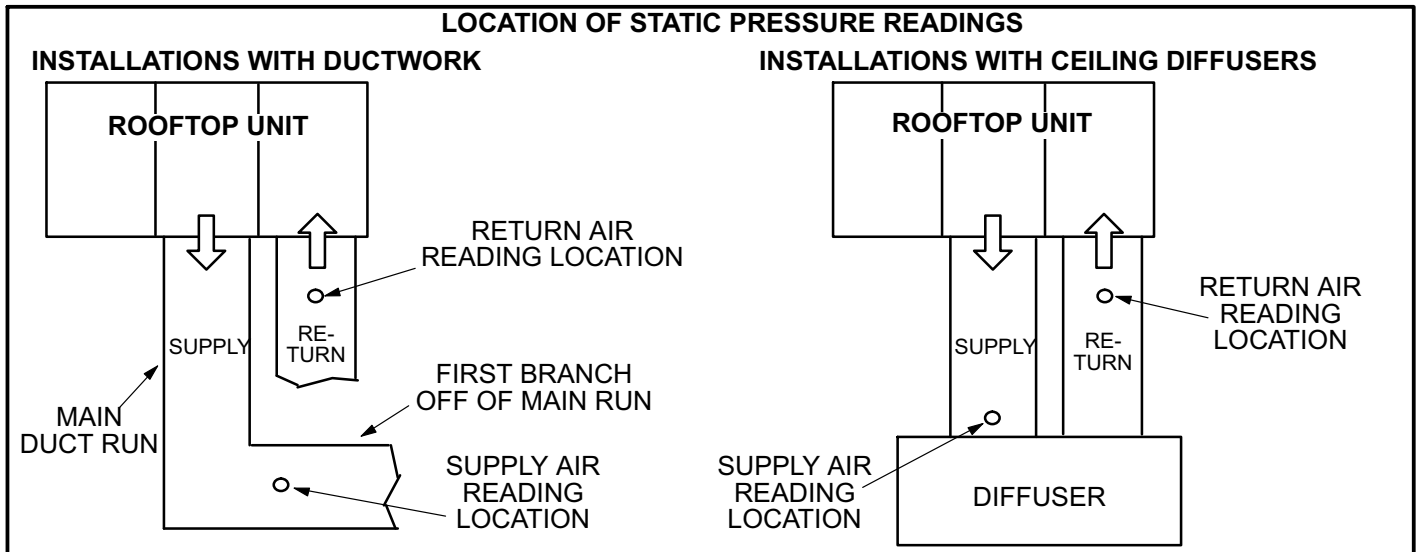

FIGURE 7

FIELD-ADJUSTABLE BLOWER SPEEDS - DIRECT DRIVE 208/230V

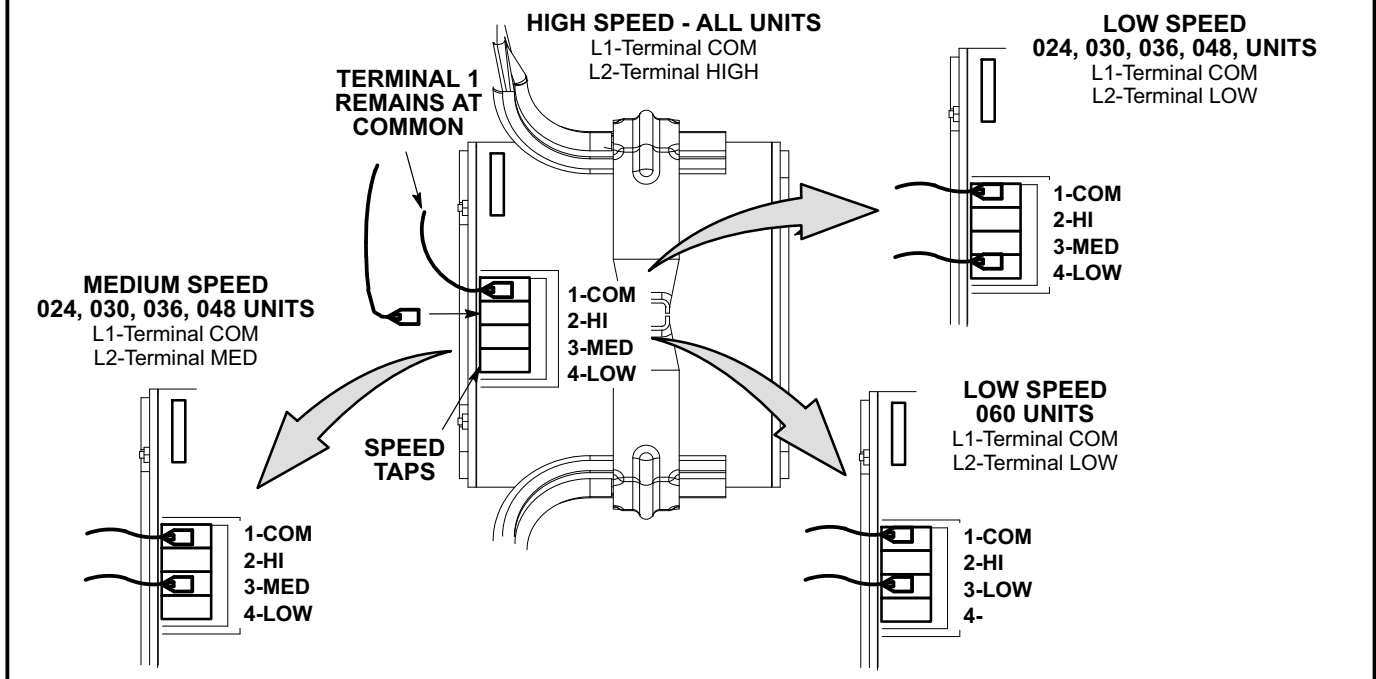

FIGURE 8

FIELD-ADJUSTABLE BLOWER SPEEDS - DIRECT DRIVE - 460/575V

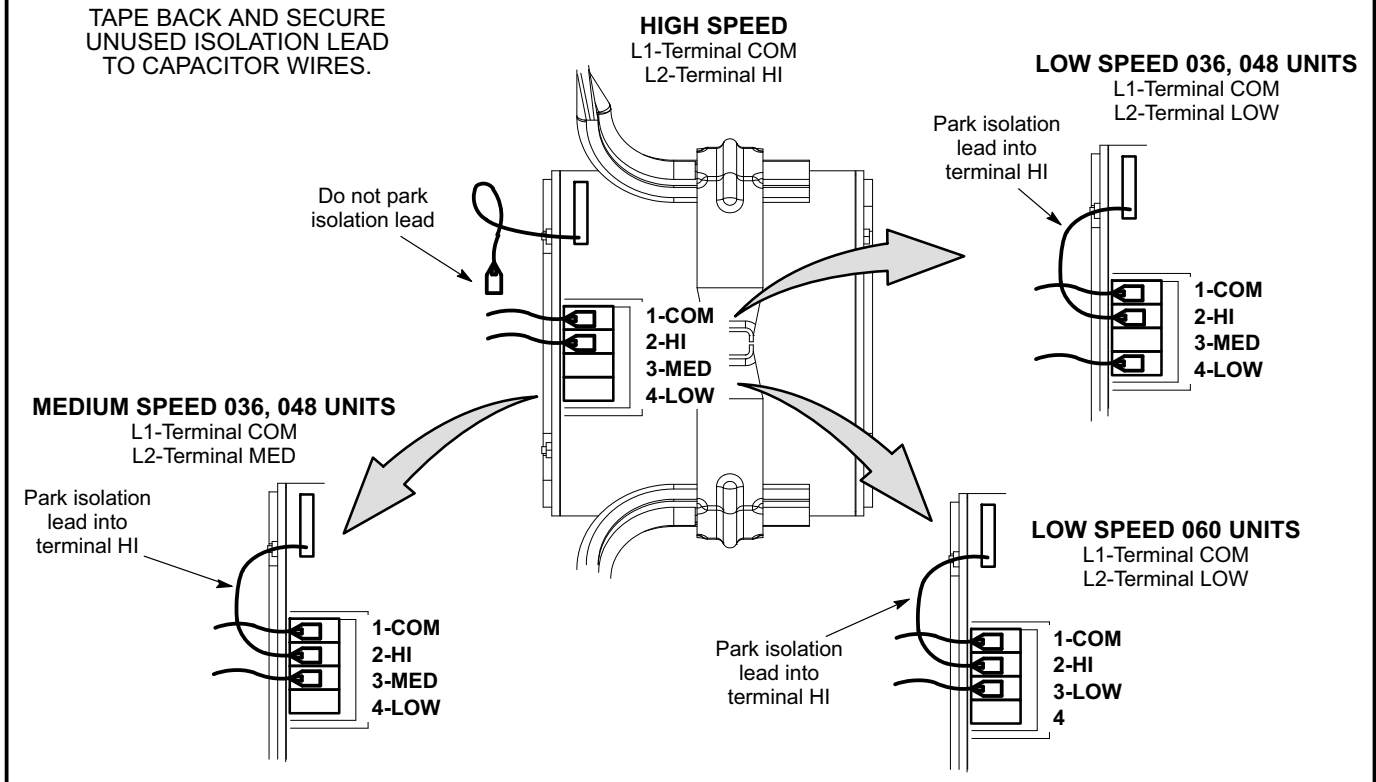

FIGURE 9

C-Determining Unit CFM - Multi-Stage, Direct Drive Blowers

- 1- Refer to multi-stage direct drive blower tables, the measured static pressure, and the factory-set blower speed to determine CFM.
- 2- If CFM is lower than the design specified CFM, move the leads as shown in figure 10 for 208/230 volt single phase units.

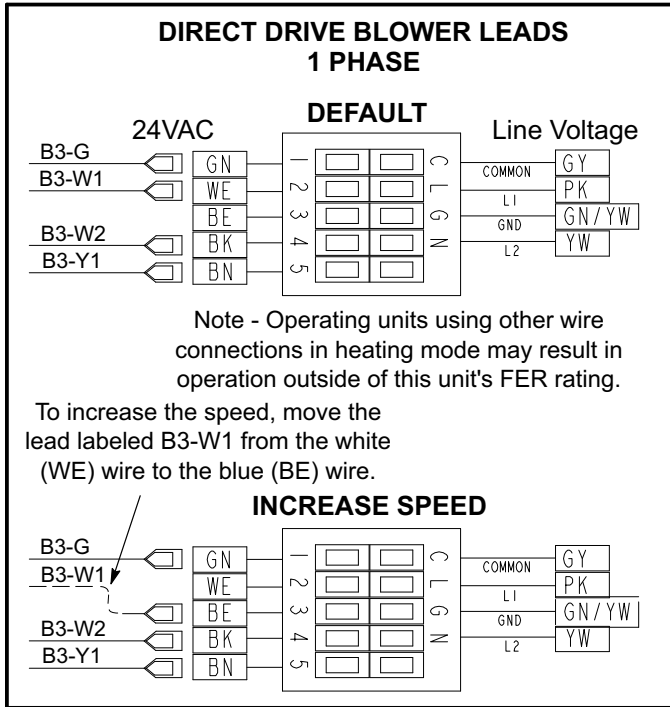

FIGURE 10

D-Determining Unit CFM - Belt Drive Blowers

IMPORTANT - KGB074, 090S4T blower (G thermostat) **CFM MUST BE ADJUSTED IN HIGH SPEED.** Disconnect factory-installed J350 low speed connector from P350. Connectors are located near the bottom of the control box. Connect J351 high speed connector to P350. Once blower CFM is set, J350 can be reconnected to operate the blower on low during ventilation only demands. See table 4.

- 1- The following measurements must be made with air filters in place.
- 2- With all access panels in place, measure static pressure external to unit (from supply to return). Blower performance data is based on static pressure readings taken in locations shown in figure 7.

Note - Static pressure readings can vary if not taken where shown.

TABLE 4
TWO-SPEED BLOWER OPERATION
KGB074, 090S4T UNITS

Thermostat	Blower Speed
G (P350/J350)*	Low
G (P350/J351)	High
W1	High
W2	High
Y1	Low
Y2	High
Dehum	High

*Factory-installed jack/plug connection.

- 3- Measure the indoor blower wheel RPM.
- 4- Referring to belt drive blower tables, use static pressure and RPM readings to determine unit CFM. Use the air resistance tables when installing units with any of the options or accessories listed.
- 5- The blower RPM can be adjusted at the motor pulley. Loosen Allen screw and turn adjustable pulley clockwise to increase CFM. Turn counterclockwise to decrease CFM. See figure 11 Do not exceed minimum and maximum number of pulley turns as shown in table 5.
- 6- *KGB074S4T and 090S4T Unit Only* - If low speed during ventilation is desired, replace J351 connector with J350.

TABLE 5
MINIMUM AND MAXIMUM PULLEY ADJUSTMENT

Belt	Min. Turns Open	Maxi. Turns Open
A Section	No minimum	5

E-Blower Belt Adjustment

Maximum life and wear can be obtained from belts only if proper pulley alignment and belt tension are maintained. Tension new belts after a 24-48 hour period of operation. This will allow belt to stretch and seat grooves. Make sure blower and motor pulley are aligned as shown in figure 12.

- 1- Loosen four bolts securing motor base to mounting frame. See figure 11.
- 2- *To increase belt tension* - Slide blower motor downward to tighten the belt. This increases the distance between the blower motor and the blower housing.
- 3- *To loosen belt tension* - Slide blower motor upward to loosen the belt. This decreases the distance between the blower motor and the blower housing.
- 4- Tighten four bolts securing motor base to the mounting frame.

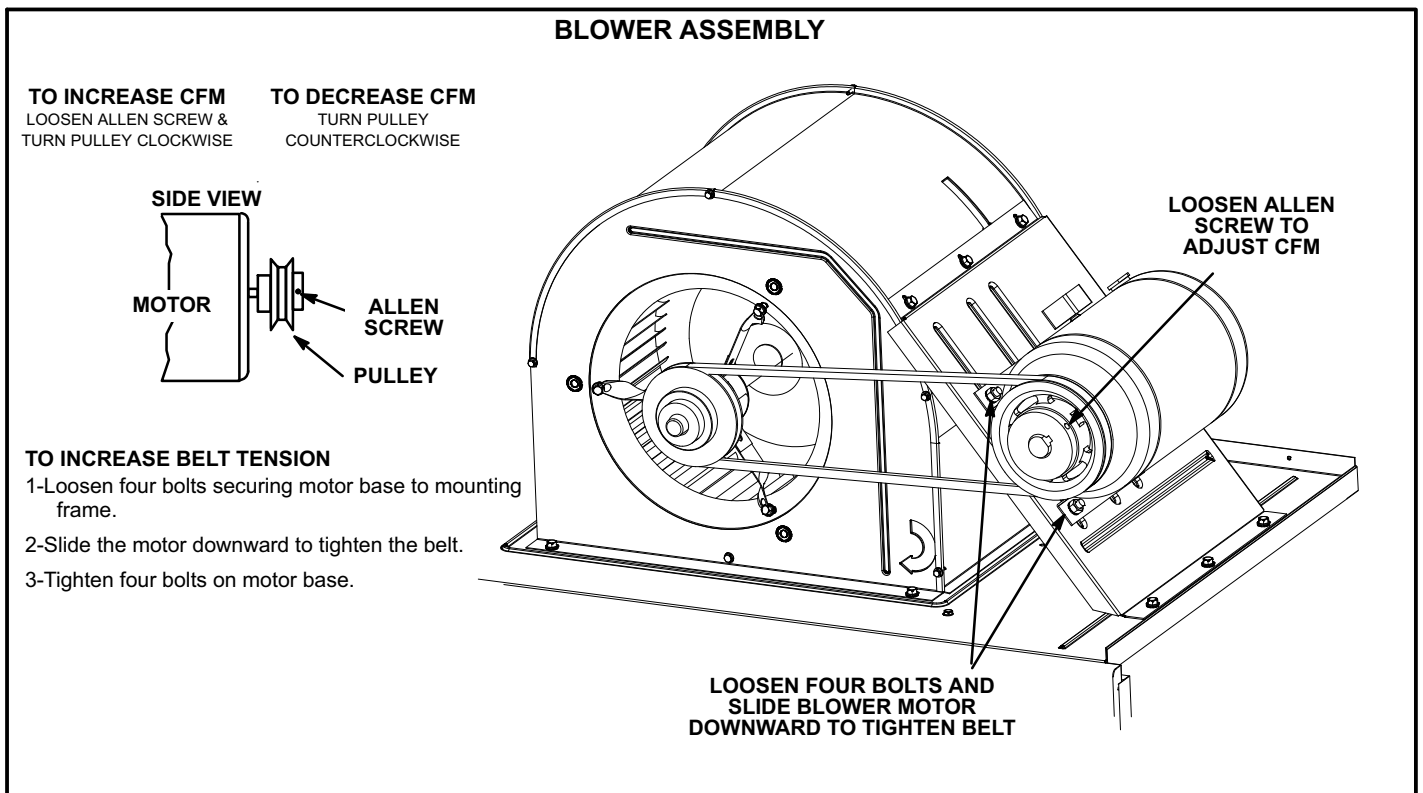

FIGURE 11

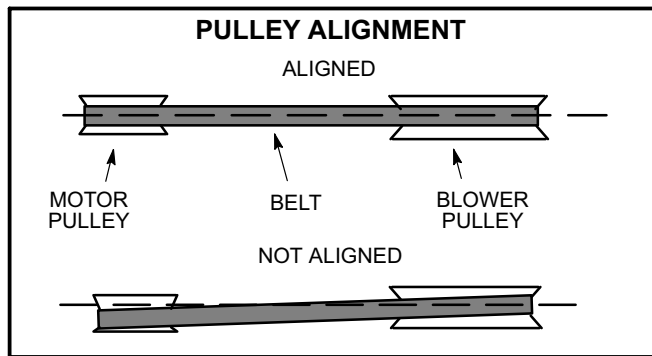

FIGURE 12

F-Blower Belt Adjustment - M Volt Units With 3 HP Blowers Equipped With A Belt Tensioner

- 1- Remove blower belt.
- 2- Remove bracket from blower housing. See figure 14.
- 3- Remove the screw from the back side of the bracket.
- 4- Move the tensioner to the appropriate adjustment hole and reinstall screw.
- 5- Replace bracket.
- 6- Replace blower belt. See figure 15.

G-Check Belt Tension - Units Not Equipped With A Belt Tensioner

Overtensioning belts shortens belt and bearing life. Check belt tension as follows:

- 1- Measure span length X. See figure 13.
- 2- Apply perpendicular force to center of span (X) with enough pressure to deflect belt 1/64" for every inch of span length or 1.5mm per 100mm of span length.

Example: Deflection distance of a 40" span would be 40/64" or 5/8".

Example: Deflection distance of a 400mm span would be 6mm.

- 3- Measure belt deflection force. For a used belt, the deflection force should be 5 lbs. (35kPa). A new belt deflection force should be 7 lbs. (48kPa).

A force below these values indicates an undertensioned belt. A force above these values indicates an overtensioned belt.

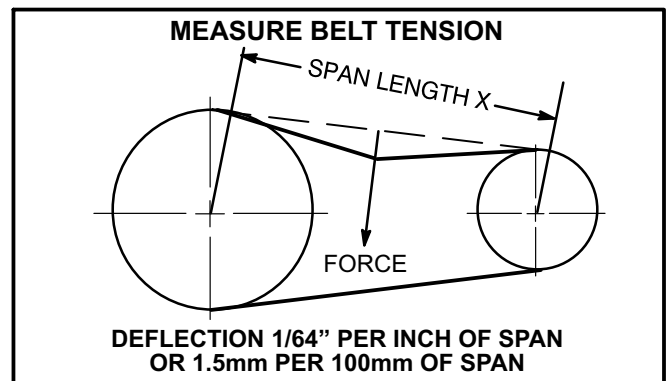

FIGURE 13

Initiate blower demand at thermostat according to instructions provided with thermostat. Unit will cycle on thermostat demand. The following steps apply to applications using a typical electro-mechanical thermostat.

H-Field-Furnished Blower Drives

For field-furnished blower drives, use belt drive blower tables to determine BHP and RPM required. Reference the drive kit specification table and manufacturer's drive number table.

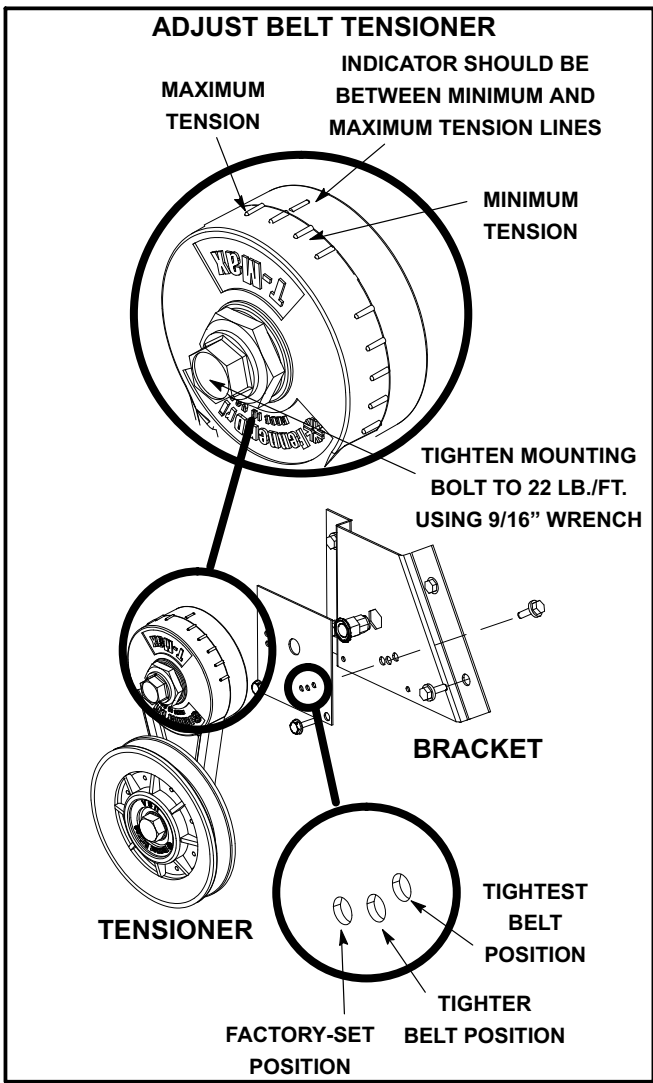

FIGURE 14

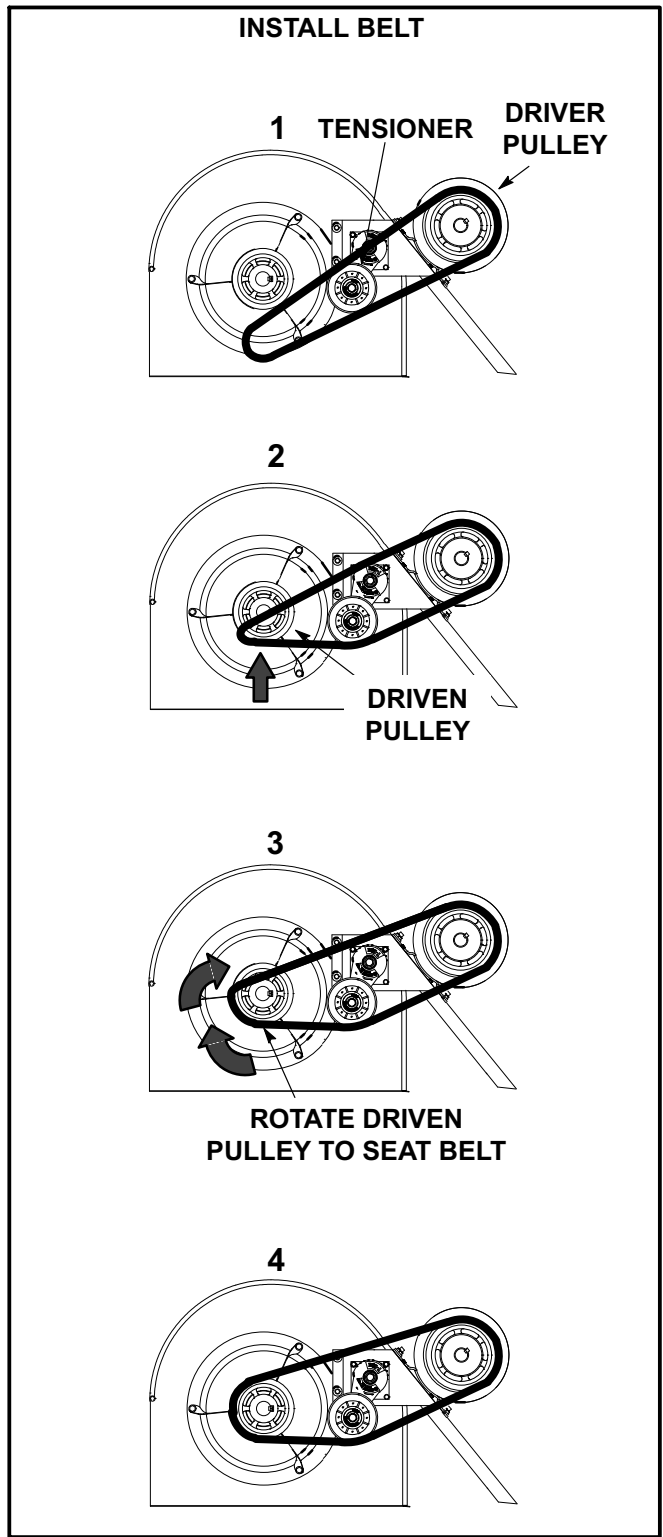

FIGURE 15

**TABLE 6
DRIVE COMPONENT MANUFACTURER'S NUMBERS**

Drive No.	DRIVE COMPONENTS					
	MOTOR PULLEY		BLOWER PULLEY		BELTS	
	Browning No.	OEM Part No.	Browning No.	OEM Part No.	Browning No.	OEM Part No.
A01	1VP34 X 7/8	31K6901	AK54 X 1	100244-19	A40	100245-17
A02	1VP34 X 7/8	31K6901	AK49 X 1	100244-18	A39	100245-16
A03	1VP34 X 7/8	31K6901	AK44X 1	100244-16	A39	100245-16
A04	1VP40 X 7/8	79J0301	AK49 X 1	100244-18	A41	100245-18
A05	1VP34 X 7/8	31K6901	AK41 X 1	100244-15	A38	100245-15
A06	1VP44 X 7/8	P-8-1488	AK51 X 1	18L2201	A41	100245-18
A07	1VP50 X 7/8	53J1501	AK54 X 1	100244-19	AX43	73K8201
A08	1VP44 X 7/8	P-8-1488	AK46 X 1	100244-17	A40	100245-17
AA01	1VP34 X 7/8	31K6901	AK69 X 1	37L4701	A51	13H0101
AA02*	1VP40 X 7/8	79J0301	BK80H	100788-03	A53	P-8-4951
AA03	1VP40 X 7/8	79J0301	AK59 X 1	31K6801	A50	100245-29
AA04	1VP44 X 7/8	P-8-1488	AK59 X 1	31K6801	A51	13H0101

*Split bushing supplier no.: H1; OEM no. 10073-04

D-GAS HEAT COMPONENTS

KGB024, 030, 036, 048, 060, 072, 074S units are available in 65,000 BTUH (19 kW) heat capacity. KG036, 048, 060, 072 074H and 090 units are available in 108,000 BTUH, (30.8 kW) heat capacity. KGA/KGB048, 060, 072 and 090 units are available in 150,000 BTUH (44 kW) heat sizes.

Two stage heat is available in units with 108,000 and 150,000 BTUH capacities.

KGA036, 048, 060, 072 and 090 units built prior to 01/01/2014 are equipped with 105,000 BTUH heating capacity.

Two stage heat units built prior to 01/01/2014 are equipped with 105,000 and 150,000 BTUH capacities. See Gas Heat Specifications on for more detail.

1-Heat Exchanger Figure 16

The KGB units use aluminized steel inshot burners with tubular aluminized steel heat exchangers and redundant gas valve. Burners in all units use a burner venturi to mix gas and air for proper combustion. Combustion takes place at each tube entrance. As hot combustion gases are drawn upward through each tube by the combustion air inducer, exhaust gases are drawn out the top and fresh air/gas mixture is drawn in at the bottom. Heat is transferred to the air stream from all surfaces of the heat exchanger tubes. The supply air blower forces air across the tubes to extract the heat of combustion. The shape of the tubes ensures maximum heat exchange.

The gas valves on two stage units accomplish staging by allowing more or less gas to the burners as called for by heating demand.

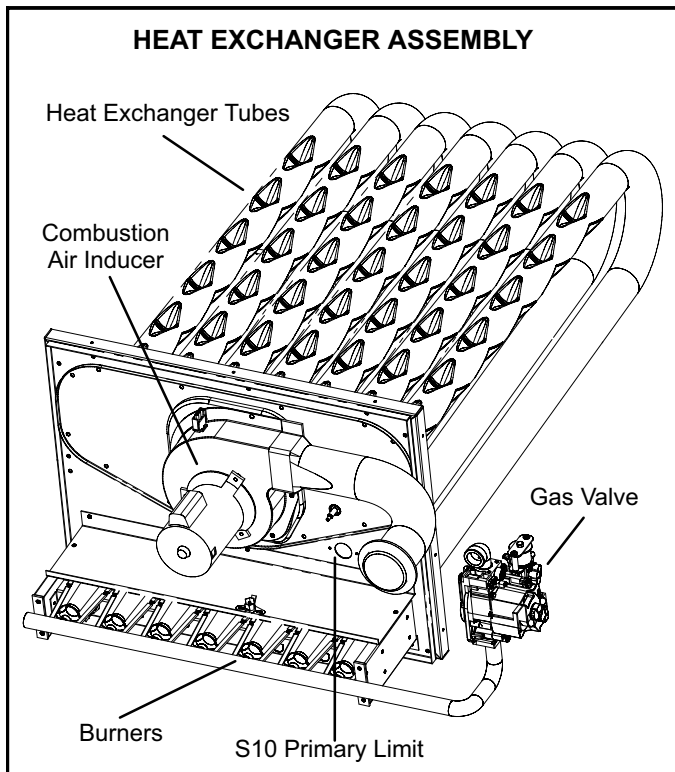

FIGURE 16

2-Burner Box Assembly (Figure 17)

The burner assembly consists of a spark electrode, flame sensing electrode and gas valve. Ignition board A3 controls all functions of the assembly.

Burners

All units use inshot burners. Burners are factory set and do not require adjustment. A peep hole with cover is furnished in the heating access panel for flame viewing. Always operate the unit with the access panel in place.

Burners can be removed individually for service. Burner maintenance and service is detailed in the SERVICE CHECKS section of this manual.

Orifice

Each burner uses an orifice which is matched to the burner input. The orifice is threaded into the burner manifold. The burner is supported by the orifice and will easily slide off for service once the mounting screws are removed from the burners.

NOTE-Do not use thread sealing compound on the orifices. Using thread sealing compound may plug the orifices.

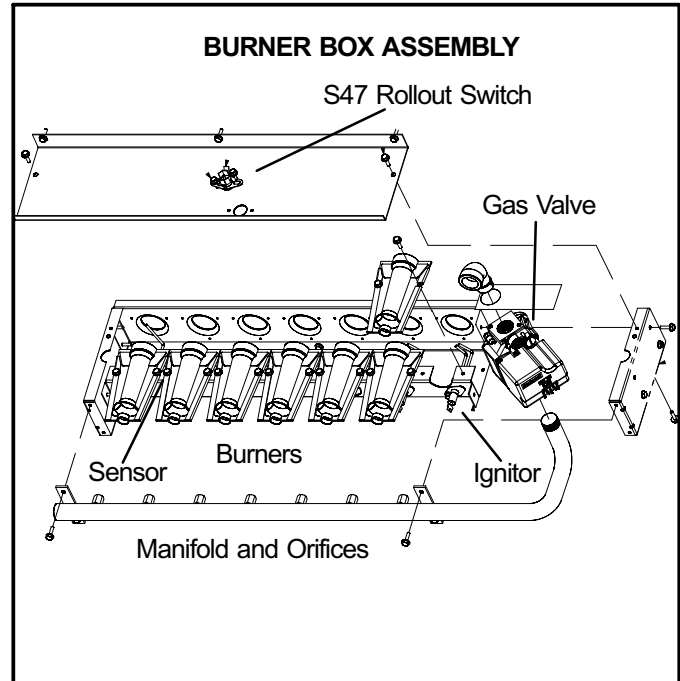

FIGURE 17

3-Primary High Temperature Limit S10

S10 is a SPST N.C. high temperature primary limit for gas heat in KGB024-090 units. S10 is located on the vestibule panel. See figure 16.

Primary limit S10 is wired to the ignition control A3. Its N.C. contacts open to de-energize the ignition control when excessive temperature is reached in the blower compartment. If the limit trips the blower relay coil K3 will be energized by ignition control A3. Limit set points are factory set and cannot be adjusted.

4-Flame Rollout Limit Switch S47

Flame rollout limit switch S47 is a SPST N.C. high temperature limit located just above the burner air intake opening in the burner enclosures (see figure 17). S47 is wired to the ignition control A3. When S47 senses flame rollout (indicating a blockage in the combustion air passages), the flame rollout limit trips, and the ignition control immediately closes the gas valve.

Limit S47 is factory preset to open at $340^{\circ}\text{F} \pm 16^{\circ}\text{F}$ on a temperature rise on all units. All flame rollout limits are manual reset.

5-Combustion Air Prove Switch S18

Prove switch S18 is a SPST N.O. switch located to the right of the induced draft assembly. S18 monitors combustion air inducer operation. Switch S18 is wired to the ignition control A3. The switch closes at *negative* $0.10''\text{W.C.} \pm 0.05''$ ($24.8 \text{ Pa} \pm 12.4 \text{ Pa}$) on pressure fall. This negative pressure fall and switch actuation allows the ignition sequence to continue (proves, by closing, that the combustion air inducer is operating before allowing the gas valve to open.) The combustion air prove switch is factory set and not adjustable.

6-Combustion Air Inducer B6

Combustion air inducers provide air to the corresponding burners while clearing the combustion chamber of exhaust gases. The inducer begins operating immediately upon receiving a thermostat demand and is de-energized when thermostat demand is satisfied.

The inducer uses a 208/230V single-phase PSC motor and a 5.24 in. x .96in. blower wheel. All motors operate at 3300RPM and are equipped with auto-reset overload protection. Inducers are supplied by various manufacturers. Ratings may vary by manufacturer. Specific inducer electrical ratings can be found on the unit rating plate.

On a heating demand (W1), the ignition control A3 initiates the heating cycle. A3 then allows 30 to seconds for the combustion air inducer to vent exhaust gases from the burners. When the combustion air inducer is purging the exhaust gases, the combustion air prove switch closes, proving that the combustion air inducer is operating before allowing the ignition sequence to continue. When the combustion air prove switch is closed and the delay is over, the ignition control activates the first stage operator of the gas valve (low fire), the spark and the flame sensing electrode. Sparking stops immediate-

ly after flame is sensed or at the end of the eight second trial for ignition.

On two stage natural gas units the inducer will operate on low speed for first stage heat (W1) and ramp up to high speed for second stage heat (W2).

All combustion air inducer motors are sealed and cannot be oiled. The inducer cannot be adjusted but can be disassembled for cleaning.

7-Combustion Air Motor Capacitor C3

The combustion air inducer motors in all KGA/KGB units require run capacitors. Capacitor C3 is connected to combustion air inducer B6. Ratings will be on side of capacitor or combustion air motor nameplate.

8-Gas Valves GV1

Units are equipped with a single stage gas valve (figure 20) or two stage gas valve (figure 21). On a call for first stage heat (low fire), the valve is energized by the ignition control simultaneously with the spark electrode. On a call for second stage heat (high fire), the second stage operator is energized directly from A3. A manual shut-off knob is provided on the valve for shut-off. Manual shut-off knob immediately closes both stages without delay. On both valves first stage (low fire) is quick opening (on and off in less than 3 seconds).

9-Spark Electrode (Ignitor) Figure 18

An electrode assembly is used for ignition spark. The electrode is mounted through holes under the right most burner location. The electrode tip protrudes into the flame envelope of the adjacent burner. The electrode assembly is fastened to burner supports and can be removed for service without removing any part of the burners.

During ignition, spark travels through the spark electrode (figure 18) and ignites the right burner. Flame travels from burner to burner until all are lit.

The spark electrode is connected to the ignition control by a 8 mm silicone-insulated stranded high voltage wire. The wire uses $1/4''$ (6.35 mm) female quick connect on both ends of the wire.

NOTE - If electrode wire must be replaced, wire and suppression must be same type cable.

The spark electrode assembly can be removed for inspection by removing the screw securing the electrode assembly and sliding it out of unit.

For proper unit operation, electrodes must be positioned and gapped correctly.

Spark gap may be checked with appropriately sized twist drills or feeler gauges. Disconnect power to the unit and remove electrode assembly. The gap should be between $0.125'' \pm 0.015''$ ($3.2 \text{ mm} \pm .4 \text{ mm}$). See figure 18.

▲ IMPORTANT

In order to maximize spark energy to electrode, high voltage wire should touch unit cabinet as little as possible.

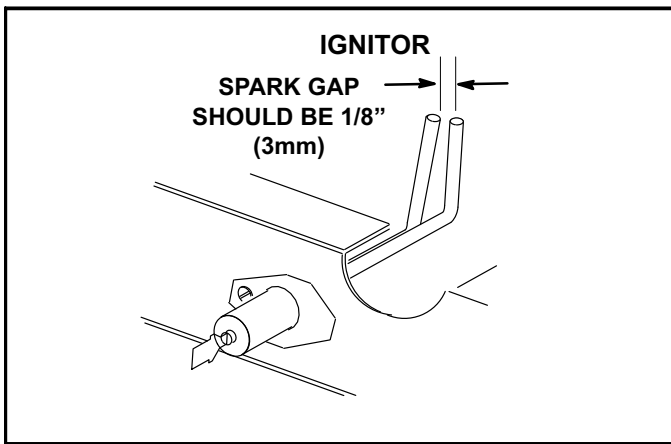

FIGURE 18

10-Flame Sensor Figure 19

A flame sensor is located under the left most side burner. The sensor is mounted through a hole in the burner support and the tip protrudes into the flame envelope of the left most burner. The sensor assembly is fastened to burner supports and can be removed for service without removing any part of the burners.

When flame is sensed by the flame sensor (indicated by microamp signal through the flame) sparking stops immediately or after the eight second trial for ignition. During operation, flame is sensed by current passed along the ground electrode (located on the spark electrode), through the flame and into the sensing electrode. The ignition control allows the gas valve to stay open as long as a flame signal (current passed through the flame) is sensed.

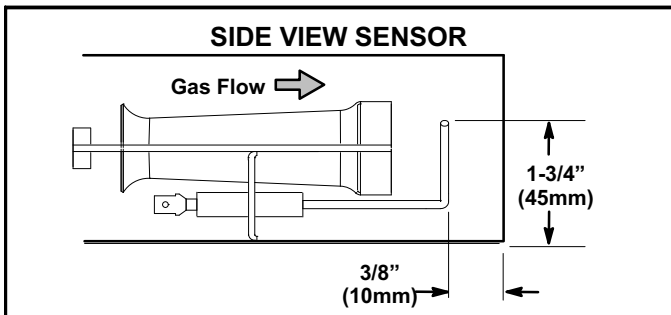

FIGURE 19

II-PLACEMENT AND INSTALLATION

Make sure the unit is installed in accordance with the installation instructions and all applicable codes. See accessories section for conditions requiring use of the optional roof mounting frame (T1CURB-AN or K1CURB-AN).

III-START UP - OPERATION

A-Preliminary and Seasonal Checks

- 1- Make sure the unit is installed in accordance with the installation instructions and applicable codes.
- 2- Inspect all electrical wiring, both field and factory installed for loose connections. Tighten as required. Refer to unit diagram located on inside of unit compressor access panel.
- 3- Check to ensure that refrigerant lines are in good condition and do not rub against the cabinet or other refrigerant lines.
- 4- Check voltage at the disconnect switch. Voltage must be within the range listed on the nameplate. If not, consult the power company and have the voltage corrected before starting the unit.
- 5- Recheck voltage and amp draw with unit running. If voltage is not within range listed on unit nameplate, stop unit and consult power company. Refer to unit nameplate for maximum rated load amps.
- 6- Inspect and adjust blower belt (see section on Blower Compartment - Blower Belt Adjustment).

B-Heating Start up

FOR YOUR SAFETY READ BEFORE LIGHTING

⚠ WARNING	
	Electric shock hazard. Can cause injury or death. Do not use this unit if any part has been under water. Immediately call a qualified service technician to inspect the unit and to replace any part of the control system and any gas control which has been under water.

⚠ WARNING	
	Danger of explosion. Can cause injury or product or property damage. If overheating occurs or if gas supply fails to shut off, shut off the manual gas valve to the appliance before shutting off electrical supply.

⚠ WARNING



Electric shock hazard. Can cause injury or death. Before attempting to perform any service or maintenance, turn the electrical power to unit **OFF** at disconnect switch(es). Unit may have multiple power supplies.

⚠ WARNING

SMOKE POTENTIAL

The heat exchanger in this unit could be a source of smoke on initial firing. Take precautions with respect to building occupants and property. Vent initial supply air outside when possible.

BEFORE LIGHTING smell all around the appliance area for gas. Be sure to smell next to the floor because some gas is heavier than air and will settle on the floor.

The gas valve may be equipped with either a gas control lever or gas control knob. Use only your hand to push the lever or turn the gas control knob. Never use tools. If the lever will not move or the knob will not push in or turn by hand, do not try to repair it. Call a qualified service technician. Force or attempted repair may result in a fire or explosion.

⚠ WARNING



Danger of explosion. Can cause injury or death. Do not attempt to light manually. Unit has a direct spark ignition system.

This unit is equipped with an automatic spark ignition system. There is no pilot. In case of a safety shutdown, move thermostat switch to **OFF** and return the thermostat switch to **HEAT** to reset ignition control.

A-Placing Unit In Operation

⚠ WARNING



Danger of explosion and fire. Can cause injury or product or property damage. You must follow these instructions exactly.

Gas Valve Operation (figures 20 and 21)

- 1- Set thermostat to lowest setting.
- 2- Turn off all electrical power to appliance.
- 3- This appliance is equipped with an ignition device which automatically lights the burner. Do **not** try to light the burner by hand.
- 4- Open or remove the heat section access panel.

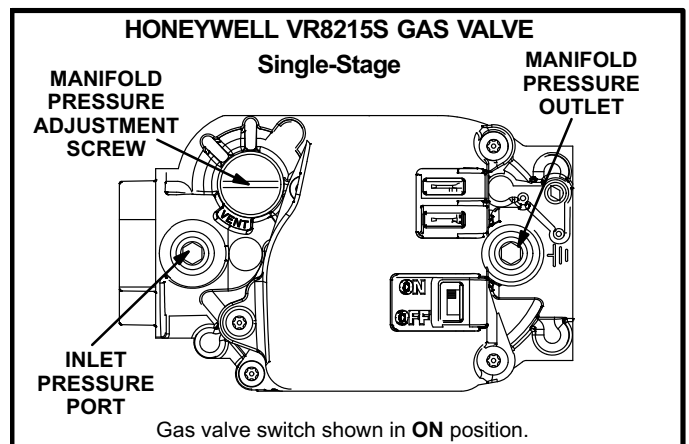

FIGURE 20

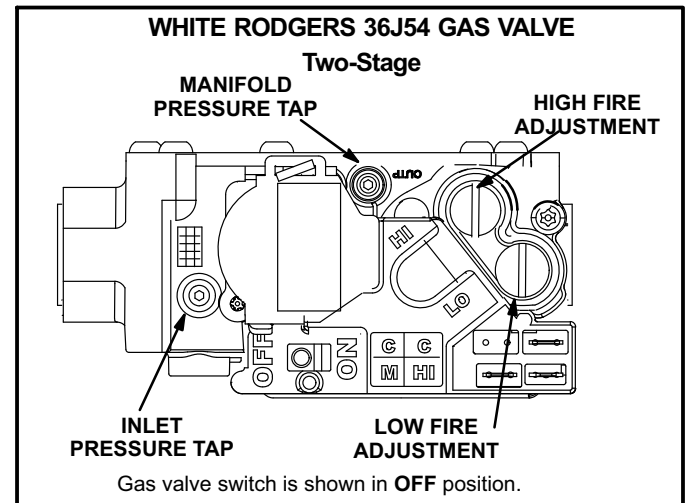

FIGURE 21

- 5- Switch gas valve to **OFF**. See figure 20 or 21 .
 - 6- Wait five (5) minutes to clear out any gas. If you then smell gas, **STOP!** Immediately call your gas supplier from a neighbor's phone. Follow the gas supplier's instructions. If you do not smell gas, go to the next step.
 - 7- Switch gas valve lever to **ON**. See figure 20 or 21 .
 - 8- Turn on all electrical power to appliance.
 - 9- Set thermostat to desired setting.
- NOTE - When unit is initially started, steps 1 through 8 may need to be repeated to purge air from gas line.*
- 10- If the appliance will not operate, follow the instructions "Turning Off Gas to Appliance" and call your service technician or gas supplier.

Turning Off Gas to Unit

- 1- If using an electromechanical thermostat, set to the lowest setting.
- 2- Before performing any service, turn off all electrical power to the appliance.
- 3- Open or remove the heat section access panel.
- 4- Switch gas valve to **OFF**.
- 5- Close or replace the heat section access panel.

C-Cooling Start up

Operation

- 1- Initiate first and second stage cooling demands according to instructions provided with thermostat.
- 2- **KGB024/090 No Economizer Installed in Unit** -A first-stage cooling demand (Y1) will energize compressor 1 and the condenser fan. An increased cooling demand (Y2) will not change operation.
Units Equipped With Economizer -
When outdoor air is acceptable, a first-stage cooling demand (Y1) will energize the economizer. An increased cooling demand (Y2) will energize compressor 1 and the condenser fan. When outdoor air is not acceptable unit will operate as though no economizer is installed.
- 3- **KGB074 No Economizer Installed in Unit** -
A first-stage cooling demand (Y1) will energize compressor 1 on low speed and the condenser fan. An increased cooling demand (Y2) will energize compressor 1 on high speed.
Units Equipped With Economizer -
When outdoor air is acceptable, a first-stage cooling demand (Y1) will energize the economizer. An increased cooling demand (Y2) will energize compressor 1 on low speed and the condenser fan. When outdoor air is not acceptable unit will operate as though no economizer is installed.
- 4- Units contain one refrigerant circuit or stage.
- 5- Unit is charged with R-410A refrigerant. See unit rating plate for correct amount of charge.
- 6- Refer to Cooling Operation and Adjustment section for proper method to check refrigerant charge.

Three Phase Scroll Compressor Voltage Phasing

Three phase scroll compressors must be phased sequentially to ensure correct compressor and blower rotation and operation. Compressor and blower are wired in phase at the factory.

- 1- Observe suction and discharge pressures and blower rotation on unit start-up.
- 2- Suction pressure must drop, discharge pressure must rise, and blower rotation must match rotation marking.

If pressure differential is not observed or blower rotation is not correct:

- 3- Disconnect all remote electrical power supplies.
- 4- Reverse any two field-installed wires connected to the line side of K1 contactor. Do not reverse wires at blower contactor.
- 5- Make sure the connections are tight.

Discharge and suction pressures should operate at their normal start-up ranges.

D-Safety or Emergency Shutdown

Turn off power to unit. Close manual and main gas valves.

IV-CHARGING

A-Refrigerant Charge and Check - All-Aluminum Coil

WARNING-Do not exceed nameplate charge under any condition.

This unit is factory charged and should require no further adjustment. If the system requires additional refrigerant, reclaim the charge, evacuate the system, and add required nameplate charge.

NOTE - System charging is not recommended below 60°F (15°C). In temperatures below 60°F (15°C), the charge must be weighed into the system.

If weighing facilities are not available, or to check the charge, use the following procedure:

IMPORTANT - Charge unit in standard cooling mode high compressor stage only.

- 1- Make sure outdoor coil is clean. Attach gauge manifolds and operate unit at full CFM in cooling mode with economizer disabled until system stabilizes (approximately five minutes). Make sure all outdoor air dampers are closed.
- 2- Compare the normal operating pressures (see table 7 through 14) to the pressures obtained from the gauges. Check unit components if there are significant differences.
- 3- Measure the outdoor ambient temperature and the suction pressure. Refer to the appropriate circuit charging curve to determine a target liquid temperature.

Note - Pressures are listed for sea level applications.

- 4- Use the same thermometer to accurately measure the liquid temperature (in the outdoor section).
 - If measured liquid temperature is higher than the target liquid temperature, add refrigerant to the system.
 - If measured liquid temperature is lower than the target liquid temperature, recover some refrigerant from the system.
- 5- Add or remove charge in increments. Allow the system to stabilize each time refrigerant is added or removed.
- 6- Continue the process until measured liquid temperature agrees with the target liquid temperature. Do not go below the target liquid temperature when adjusting charge. Note that suction pressure can change as charge is adjusted.
- 7- Example KG/KC 090: At 95°F outdoor ambient and a measured suction pressure of 130psig, the target liquid temperature is 99°F. For a measured liquid temperature of 106°F, add charge in increments until measured liquid temperature agrees with the target liquid temperature.

TABLE 7 580708-02

KGB/KCB024 Normal Operating Pressures											
Outdoor Coil Entering Air Temperature											
65 °F		75 °F		85 °F		95 °F		105 °F		115 °F	
Suct (psig)	Disc (psig)	Suct (psig)	Disc (psig)	Suct (psig)	Disc (psig)	Suct (psig)	Disc (psig)	Suct (psig)	Disc (psig)	Suct (psig)	Disc (psig)
113	220	114	255	116	302	116	355	118	416	122	498
121	223	123	253	145	296	125	354	129	411	129	492
139	234	143	256	145	299	145	343	146	400	148	460
160	233	164	261	167	300	169	345	171	397	172	458

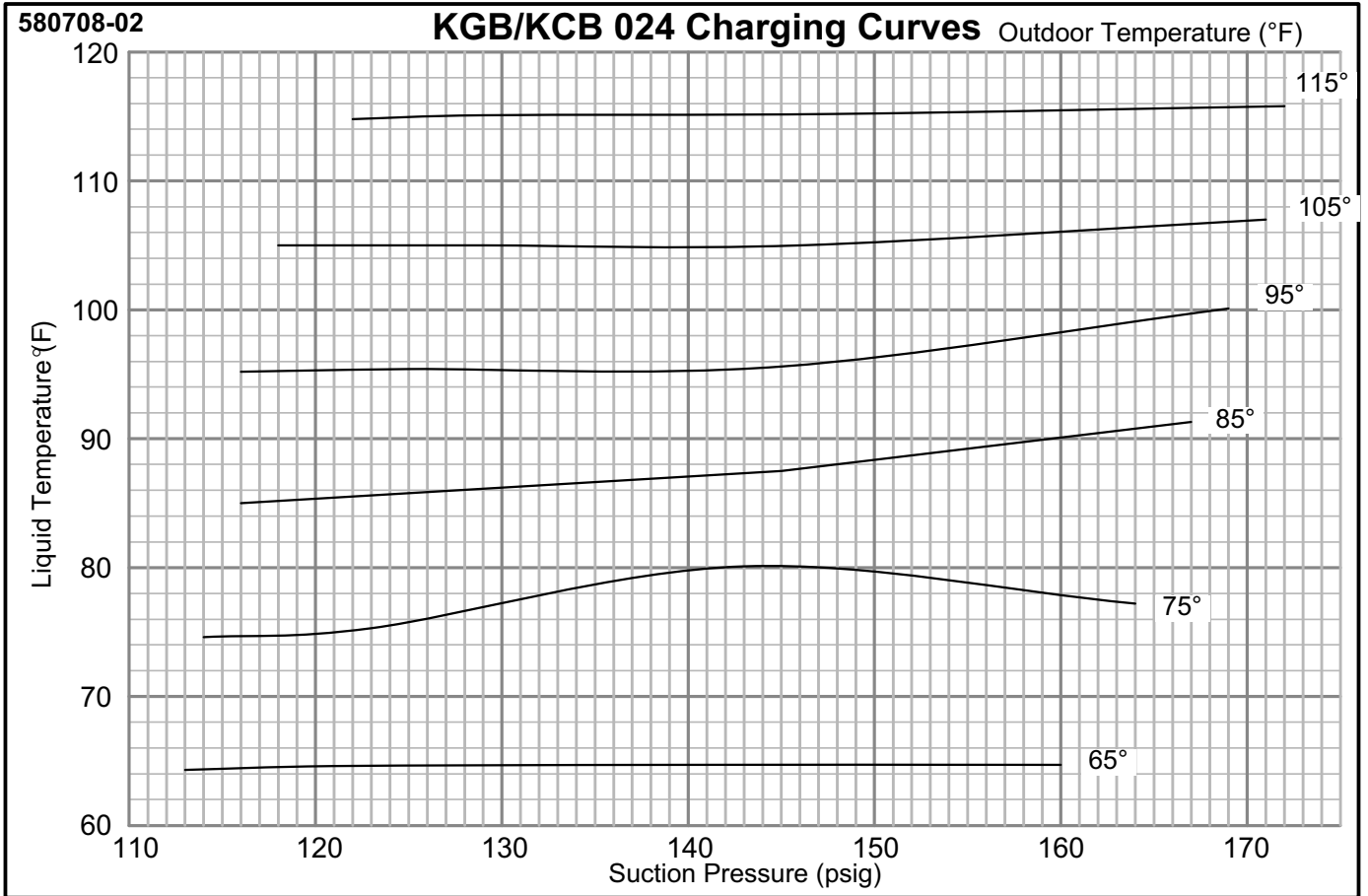

TABLE 8 580709-02

KGB/KCB030 Normal Operating Pressures

Outdoor Coil Entering Air Temperature

65 °F		75 °F		85 °F		95 °F		105 °F		115 °F	
Suct (psig)	Disc (psig)	Suct (psig)	Disc (psig)	Suct (psig)	Disc (psig)	Suct (psig)	Disc (psig)	Suct (psig)	Disc (psig)	Suct (psig)	Disc (psig)
114	222	115	262	117	309	120	367	122	474	126	575
123	221	124	258	125	306	128	355	130	434	134	568
143	228	144	260	148	301	150	348	151	404	172	473
161	237	165	270	167	310	171	356	174	407	178	458

580709-02

KGB/KCB 030 Charging Curves Outdoor Temperature (°F)

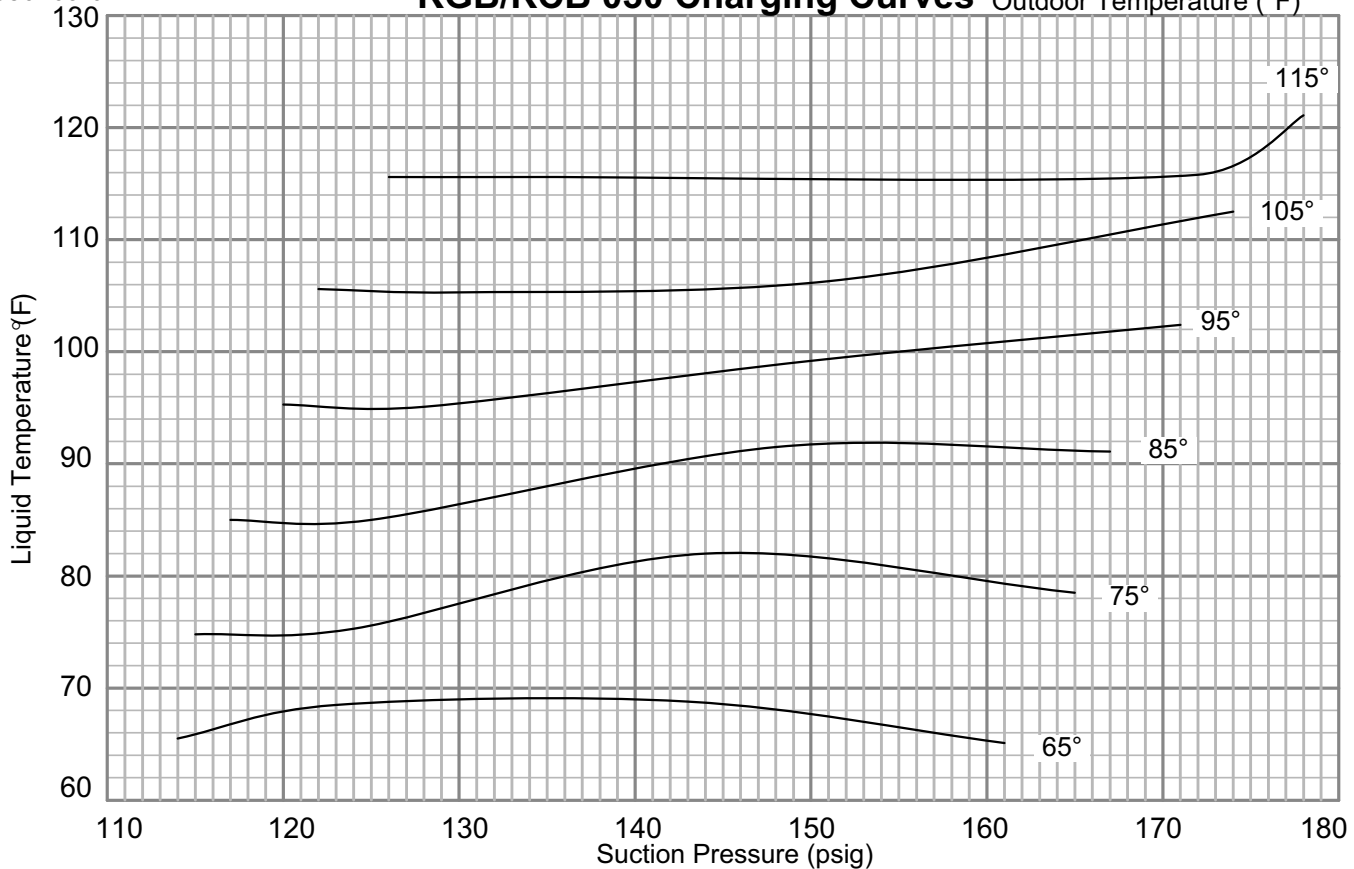

TABLE 9 580710-02

KGB/KCB036 Normal Operating Pressures											
Outdoor Coil Entering Air Temperature											
65 °F		75 °F		85 °F		95 °F		105 °F		115 °F	
Suct (psig)	Disc (psig)	Suct (psig)	Disc (psig)	Suct (psig)	Disc (psig)	Suct (psig)	Disc (psig)	Suct (psig)	Disc (psig)	Suct (psig)	Disc (psig)
113	231	115	265	117	305	118	355	120	412	123	485
122	232	124	268	126	309	129	355	130	412	132	475
137	243	141	276	144	317	146	362	149	414	151	474
152	261	157	293	162	331	166	374	169	423	172	479

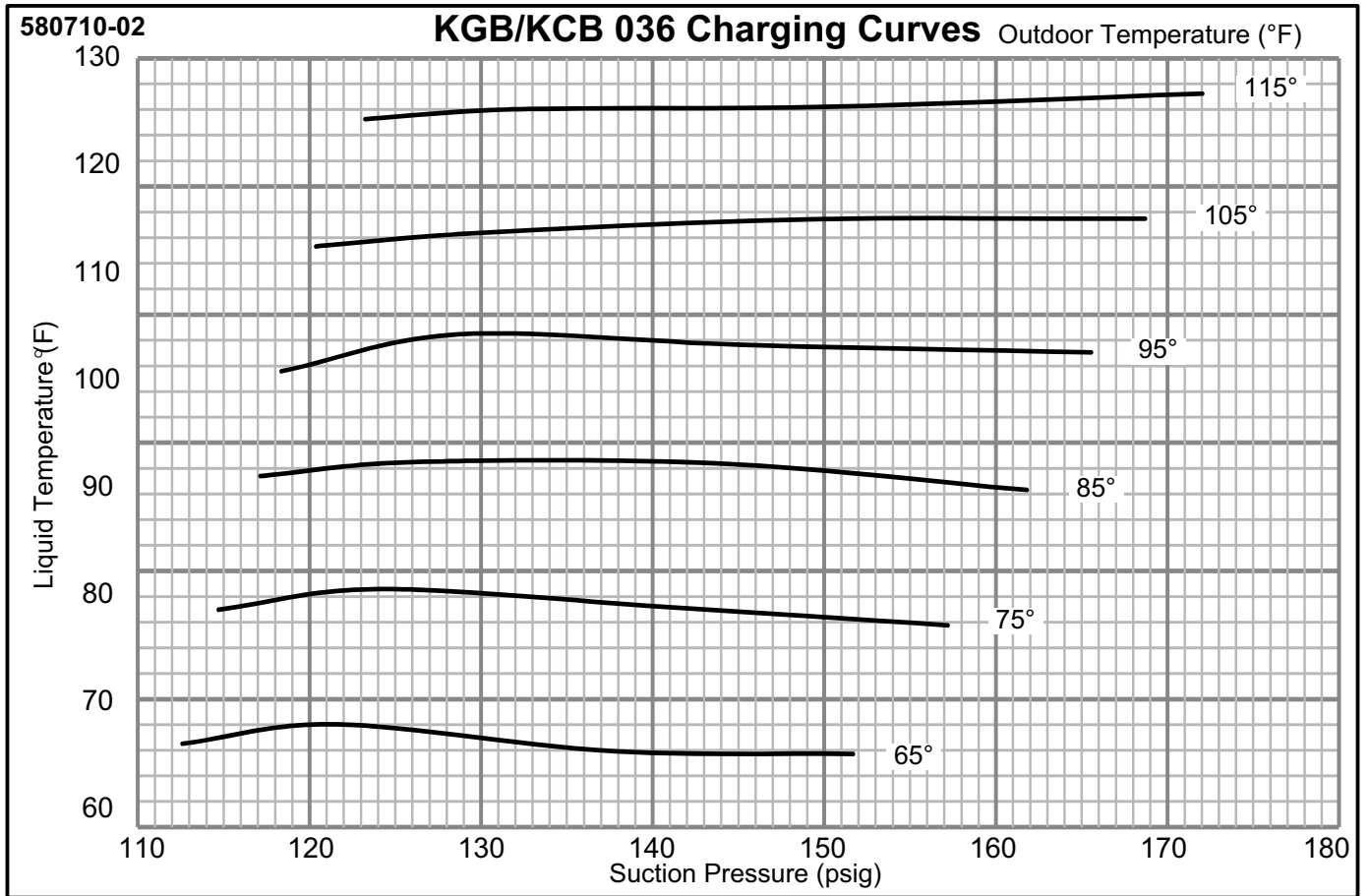

TABLE 10 580711-02

KGB/KCB048 Normal Operating Pressures

Outdoor Coil Entering Air Temperature											
65 °F		75 °F		85 °F		95 °F		105 °F		115 °F	
Suct (psig)	Disc (psig)	Suct (psig)	Disc (psig)	Suct (psig)	Disc (psig)	Suct (psig)	Disc (psig)	Suct (psig)	Disc (psig)	Suct (psig)	Disc (psig)
110	243	112	282	112	331	114	382	116	445	118	523
119	248	120	286	122	331	122	387	126	440	128	510
134	252	138	290	140	336	142	385	144	441	147	505
153	268	156	302	160	347	164	392	167	442	171	501

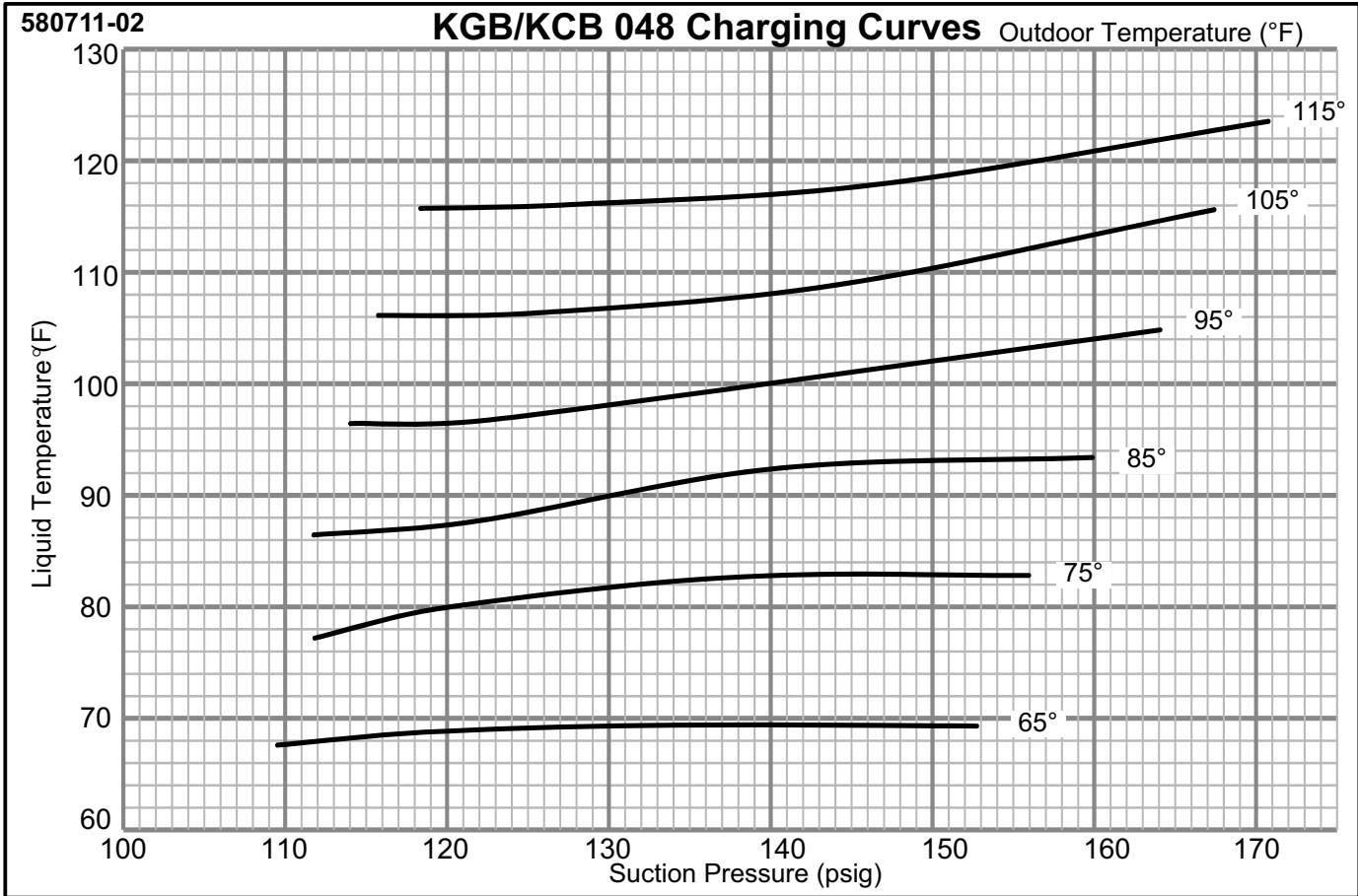

TABLE 11 580712-02

KGB/KCB 060 Normal Operating Pressures											
Outdoor Coil Entering Air Temperature											
65 °F		75 °F		85 °F		95 °F		105 °F		115 °F	
Suct (psig)	Disc (psig)	Suct (psig)	Disc (psig)	Suct (psig)	Disc (psig)	Suct (psig)	Disc (psig)	Suct (psig)	Disc (psig)	Suct (psig)	Disc (psig)
110	235	112	275	113	323	115	382	117	463	120	561
119	239	121	278	122	325	124	381	126	455	128	547
137	248	140	286	143	329	145	377	147	432	148	503
155	263	160	298	163	339	167	385	170	438	173	498

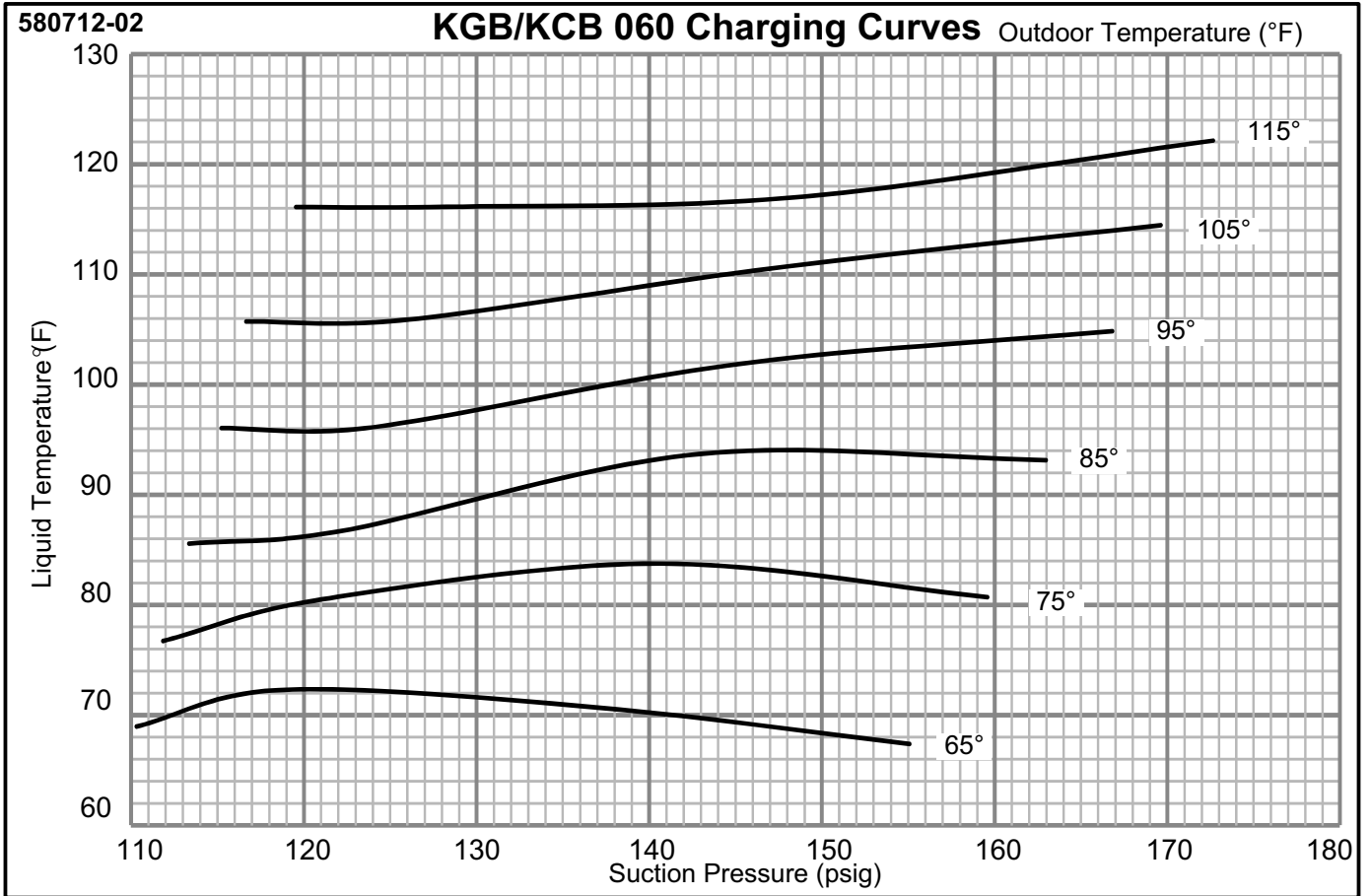

TABLE 12 580996-01

KGB/KCB 072H Normal Operating Pressures											
Outdoor Coil Entering Air Temperature											
65 °F		75 °F		85 °F		95 °F		105 °F		115 °F	
113	261	115	300	116	347	118	402	119	492	123	512
122	266	124	307	126	349	126	402	128	467	132	518
140	277	143	316	145	360	147	411	149	472	151	540
159	291	161	329	164	375	168	423	172	478	174	537

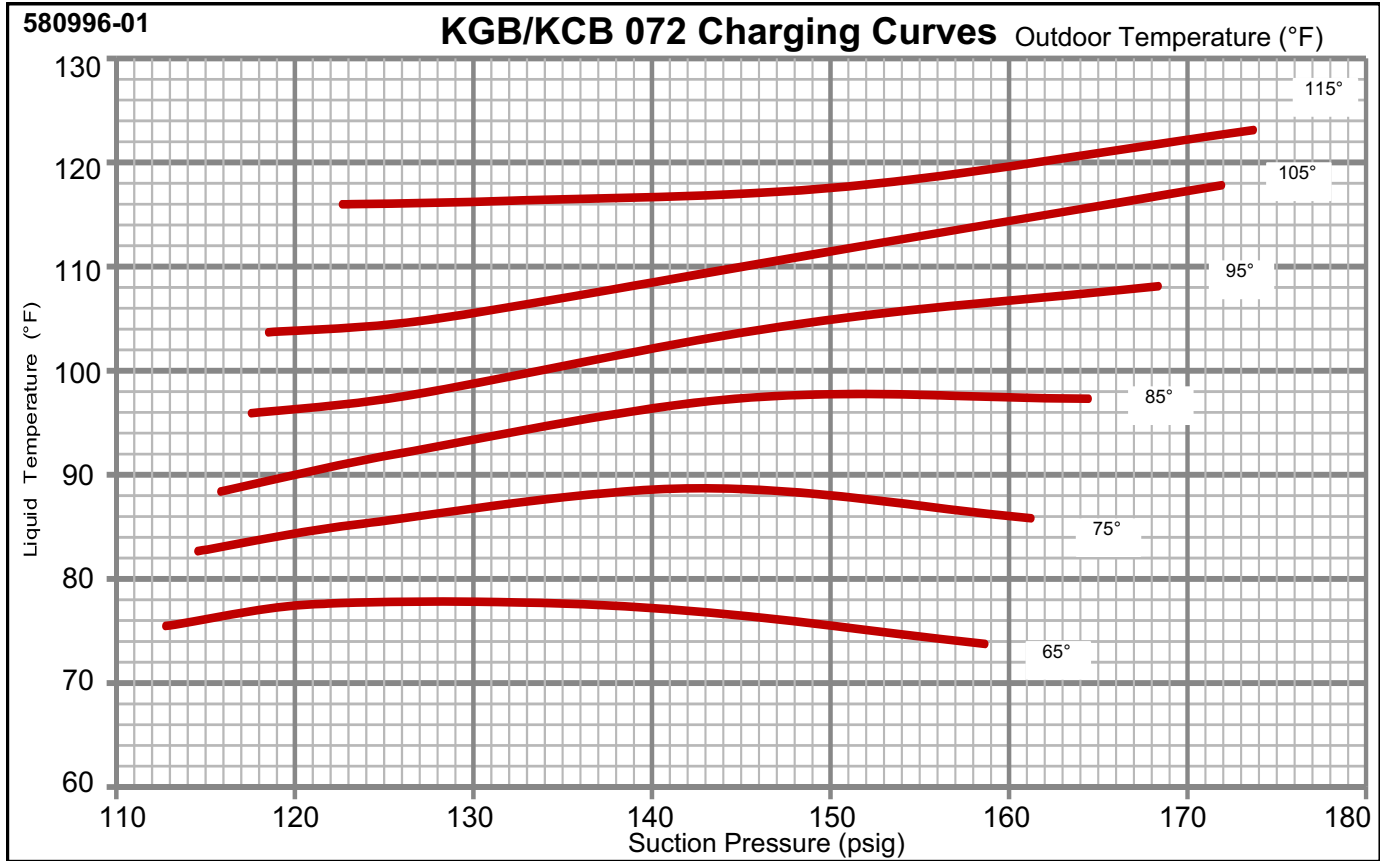

TABLE 13 580791-01

KGB/KCB 074S & H Normal Operating Pressures											
Outdoor Coil Entering Air Temperature											
65 °F		75 °F		85 °F		95 °F		105 °F		115 °F	
Suct (psig)	Disc (psig)	Suct (psig)	Disc (psig)	Suct (psig)	Disc (psig)	Suct (psig)	Disc (psig)	Suct (psig)	Disc (psig)	Suct (psig)	Disc (psig)
112	257	113	298	114	348	116	403	118	476	121	602
120	261	122	301	123	347	124	403	127	466	129	556
136	271	140	310	143	354	145	401	145	460	147	525
154	290	157	327	161	370	165	416	168	468	171	526

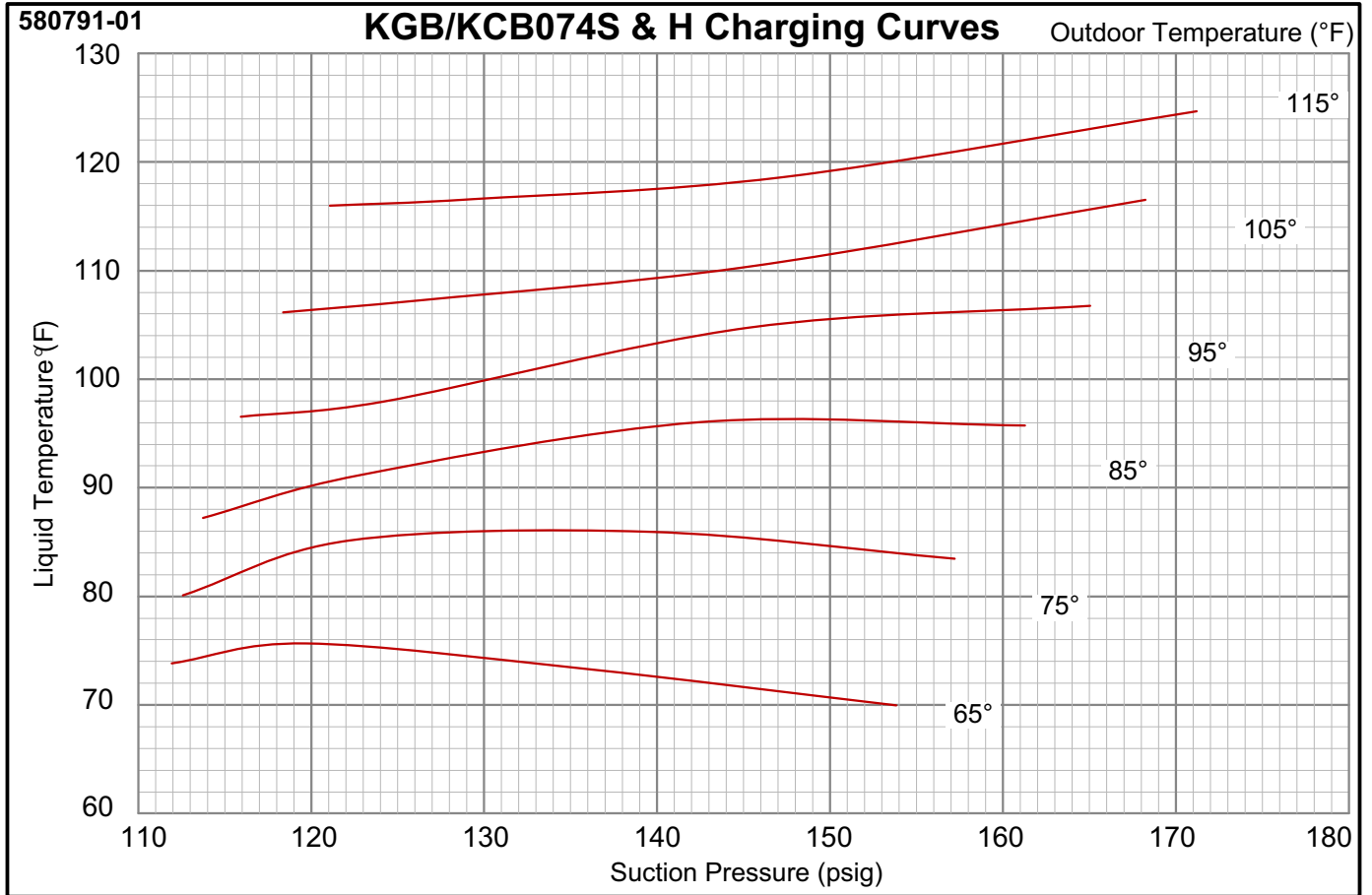
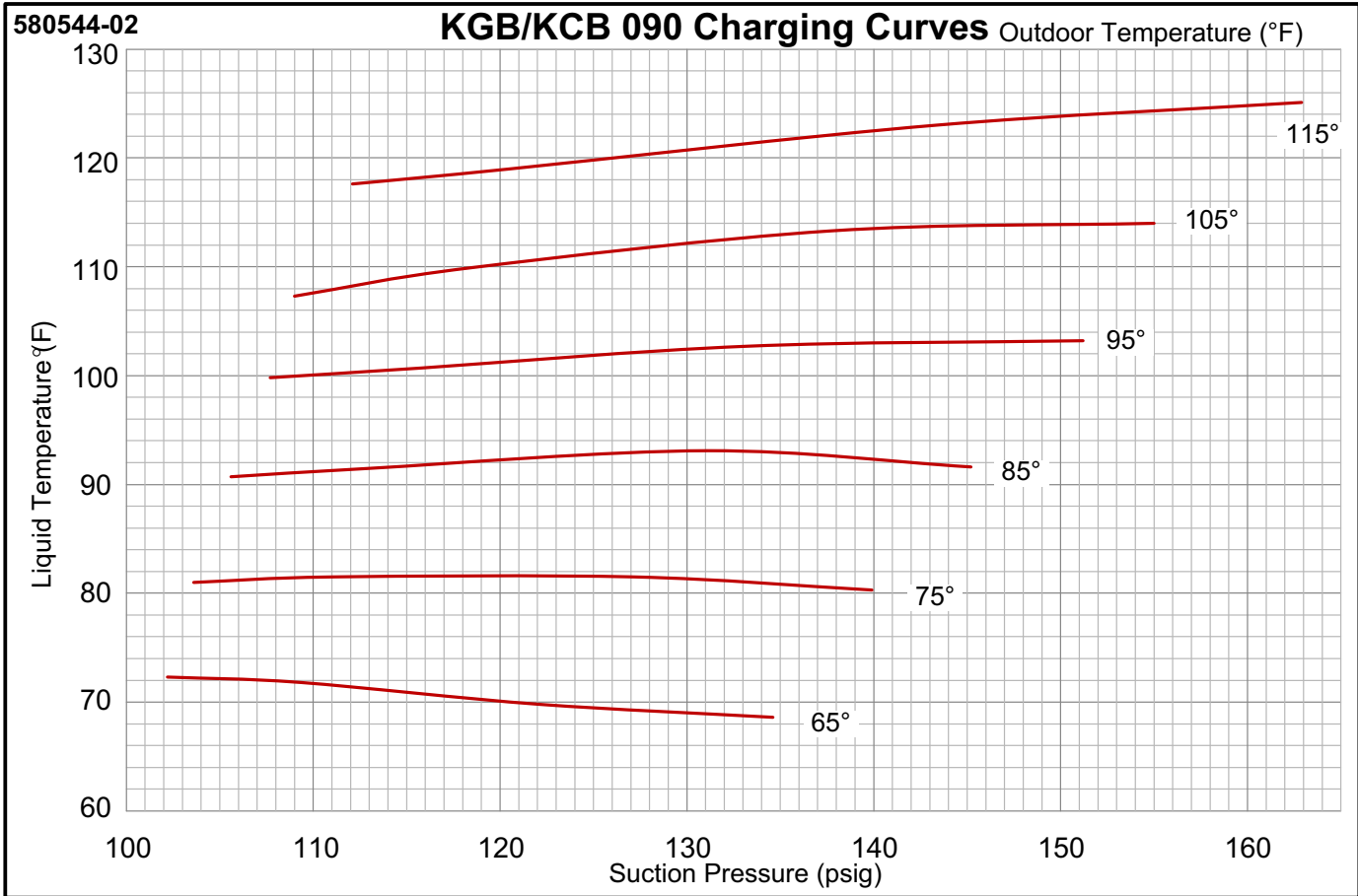

TABLE 14 580544-02

KGB/KCB 090 Normal Operating Pressures											
Outdoor Coil Entering Air Temperature											
65 °F		75 °F		85 °F		95 °F		105 °F		115 °F	
Suct (psig)	Disc (psig)	Suct (psig)	Disc (psig)	Suct (psig)	Disc (psig)	Suct (psig)	Disc (psig)	Suct (psig)	Disc (psig)	Suct (psig)	Disc (psig)
102	259	104	298	106	341	108	390	109	441	112	506
109	264	111	303	113	347	116	396	118	450	121	516
122	275	127	315	131	359	133	410	138	460	143	518
135	289	140	327	145	370	151	421	155	470	163	533



B-Refrigerant Charge and Check - Fin/Tube Coil

KG/KC 024S, 030S, 036S, 048S, 060S, 074S, 090S

WARNING-Do not exceed nameplate charge under any condition.

This unit is factory charged and should require no further adjustment. If the system requires additional refrigerant, re-claim the charge, evacuate the system, and add required nameplate charge.

NOTE - System charging is not recommended below 60°F (15°C). In temperatures below 60°F (15°C) , the charge must be weighed into the system.

If weighing facilities are not available, or to check the charge, use the following procedure:

IMPORTANT - Charge unit in standard cooling mode.

- 1- Attach gauge manifolds and operate unit in cooling mode with economizer disabled until system stabilizes (approximately five minutes). Make sure outdoor air dampers are closed.
- 2- Check each system separately with all stages operating.
- 3- Use a thermometer to accurately measure the outdoor ambient temperature.
- 4- Apply the outdoor temperature to table 15-21 to determine normal operating pressures. Pressures are listed for sea level applications at 80°F dry bulb and 67°F wet bulb return air.
- 5- Compare the normal operating pressures to the pressures obtained from the gauges. Minor variations in these pressures may be expected due to differences in installations. Significant differences could mean that the system is not properly charged or that a problem exists with some component in the system. **Correct any system problems before proceeding.**
- 6- If discharge pressure is high, remove refrigerant from the system. If discharge pressure is low, add refrigerant to the system.
 - Add or remove charge in increments.
 - Allow the system to stabilize each time refrigerant is added or removed.
- 7- Use the following approach method along with the normal operating pressures to confirm readings.

**TABLE 15 580942-01
KGB/KCB024S Fin/Tube - W & W/O Reheat**

Outdoor Coil Entering Air Temp	Discharge ±10psig	Suction ±5 psig
65° F	213	140
75° F	248	142
85° F	285	144
95° F	328	145
105° F	377	146
115° F	431	148

**TABLE 16 580943-01
KGB/KCB030S Fin/Tube - W & W/O Reheat**

Outdoor Coil Entering Air Temp	Discharge ±10psig	Suction ±5 psig
65° F	222	145
75° F	255	147
85° F	295	148
95° F	341	149
105° F	389	151
115° F	443	153

**TABLE 17 580944-01
KGB/KCB036S Fin/Tube - W & W/O Reheat**

Outdoor Coil Entering Air Temp	Discharge ±10psig	Suction ±5 psig
65° F	234	135
75° F	269	140
85° F	310	144
95° F	355	145
105° F	404	148
115° F	458	152

**TABLE 18 580945-01
KGB/KCB048S Fin/Tube - W & W/O Reheat**

Outdoor Coil Entering Air Temp	Discharge ±10psig	Suction ±5 psig
65° F	252	130
75° F	290	135
85° F	332	138
95° F	378	141
105° F	427	143
115° F	484	146

**TABLE 19 580946-01
KGB/KCB060S Fin/Tube - W & W/O Reheat**

Outdoor Coil Entering Air Temp	Discharge ±10psig	Suction ±5 psig
65° F	244	138
75° F	280	140
85° F	322	142
95° F	367	143
105° F	417	144
115° F	472	148

**TABLE 20 580947-01
KGB/KCB074S Fin/Tube - W & W/O Reheat**

Outdoor Coil Entering Air Temp	Discharge ±10psig	Suction ±5 psig
65° F	267	140
75° F	301	142
85° F	349	144
95° F	397	145
105° F	448	146
115° F	504	148

**TABLE 21 580948-01
KGB/KCB090S Fin/Tube - W & W/O Reheat**

Outdoor Coil Entering Air Temp	Discharge ±10psig	Suction ±5 psig
65° F	272	117
75° F	311	123
85° F	356	127
95° F	406	133
105° F	457	137
115° F	513	138

**C - Charge Verification - Approach Method
(Fin/Tube Coil Continued)**

- Using the same thermometer, compare liquid temperature to outdoor ambient temperature.

Approach Temperature = Liquid temperature (at condenser outlet) minus ambient temperature.

- Approach temperature should match values in table 22. An approach temperature greater than value shown indicates an undercharge. An approach temperature less than value shown indicates an overcharge.
- The approach method is not valid for grossly over or undercharged systems. Use table 15 through 21 as a guide for typical operating pressures.

**TABLE 22
APPROACH TEMPERATURE - Fin/Tube - TXV**

KG/KC Unit	Liquid Temp. Minus Ambient Temp.
024S, 030S, 036S, 090S	1°F ± 1 (0.6°C ± 0.5)
048S	2°F ± 1 (1.1°C ± 0.5)
060S	3°F ± 1 (1.7°C ± 0.5)
074S	4°F ± 1 (2.2°C ± 0.5)

**D - Charge Verification - Subcooling Method AHRI Testing
(Fin/Tube Coil Continued)**

- Attach gauge manifold to the liquid line. With the economizer disabled, operate the unit in **cooling mode (at high speed on 2-speed units)**.
- Use the liquid line pressure and a PT chart to determine the saturated liquid temperature.
- Measure the liquid line temperature at the condenser outlet.

Subcooling Temperature = Liquid Saturated Temperature Minus Liquid Temperature.

- The subcooling temperature should be as shown in figure 23. A subcooling temperature greater than this value indicates an overcharge. A subcooling temperature less than this value indicates an undercharge.

**TABLE 23
SUBCOOLING TEMPERATURE**

KCB/KGB Unit	Liquid Saturated Temp. Minus Liquid Temperature
024S	7°F ± 1 (3.9°C ± 0.5)
030S	8°F ± 1 (4.4°C ± 0.5)
036S, 060S	9.5°F ± 1 (5.2°C ± 0.5)
048S	11.5°F ± 1 (6.3°C ± 0.5)
074S	12.5°F ± 1 (6.9°C ± 0.5)
090S	10°F ± 1 (5.5°C ± 0.5)

V- SYSTEM SERVICE CHECKS

A-Heating System Service Checks

All KGB units are C.S.A. design certified without modification.

Before checking piping, check with gas company or authorities having jurisdiction for local code requirements. Refer to the KGB Installation instruction for more information.

1-Gas Piping

Gas supply piping must not allow more than 0.5"W.C. (124.3 Pa) drop in pressure between the gas meter and the unit. Supply gas pipe must not be smaller than the unit gas connection. Refer to installation instructions for details.

2-Testing Gas Piping

NOTE-In case emergency shutdown is required, turn off the main manual shut-off valve and disconnect the main power to the unit. These controls should be properly labeled by the installer.

When pressure testing gas lines, the gas valve must be disconnected and isolated. **Gas valves can be damaged if subjected to more than 0.5 psig [14"W.C. (3481 Pa)].** See figure 22.

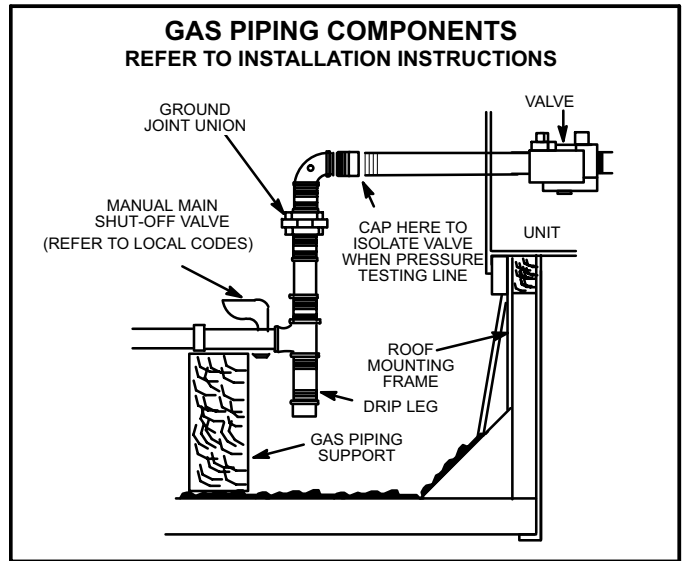

FIGURE 22

When checking piping connection for gas leaks, use the preferred means. Common kitchen detergents can cause harmful corrosion on various metals used in gas piping. The use of specialty Gas Leak Detector is strongly recommended. It is available through part number 31B2001. See CORP 8411-L10, for further details.

Do not use matches, candles, flame or any other source of ignition to check for gas leaks.

3-Testing Gas Supply Pressure

When testing gas supply pressure, connect test gauge to the inlet pressure tap located on unit gas valve GV1. Test supply gas pressure with unit firing at maximum rate (both stages energized). Make sure the reading falls within the range of the following values. Low pressure may result in erratic operation or "underfire." High pressure can result in permanent damage to the gas valve or "overfire." For natural gas units, operating pressure at the unit gas connection must be between 4.5"W.C. and 10.5"W.C. For L.P. gas units, operating pressure at the unit gas connection must be between 10.5"W.C. and 13.0"W.C.

On multiple unit installations, each unit should be checked separately while operating at maximum rate, beginning with the one closest to the supply gas main and progressing to the one furthest from the main. Multiple units should also be tested with and without the other units operating. Supply pressure must fall within the range listed in the previous paragraph.

4-Check and Adjust Manifold Pressure

After line pressure has been checked and adjusted, check manifold pressure. Move test gauge to the outlet pressure tap located on unit gas valve GV1. See figures 20 and 21 for location of pressure tap on the gas valve.

The manifold pressure is factory set and should not require adjustment. If manifold pressure is incorrect and no other source of improper manifold pressure can be found, the valve must be replaced. See figure 20 and 21 for location of gas valve (manifold pressure) adjustment screw.

All gas valves are factory regulated. The gas valve should completely and immediately cycle off in the event of gas or power failure. The manual shut-off knob can be used to immediately shut off gas supply.

⚠ CAUTION

For safety, connect a shut-off valve between the manometer and the gas tap to permit shut off of gas pressure to the manometer.

Manifold Adjustment Procedure

- 1- Connect test gauge to the outlet pressure tap on the gas valve. Start the unit (call for second stage heat) and allow five minutes for the unit to reach steady state.
- 2- While waiting for the unit to stabilize, notice the flame. The flame should be stable without flashback and should not lift from the burner heads. Natural gas should burn basically blue with some clear streaks. L.P. gas should burn mostly blue with some clear yellow streaks.
- 3- After allowing the unit to stabilize for five minutes, record the manifold pressure and compare to the values below.

- Natural Gas Units - Low Fire - 2.0" w.c.
- Natural Gas Units - High Fire - 3.5" w.c.
- LP Gas Units - Low Fire - 5.9" w.c.
- LP Gas Units - High Fire - 10.5" w.c.

5-Proper Gas Flow

Furnace should operate at least 5 minutes before checking gas flow. Determine time in seconds for two revolutions of gas through the meter. (Two revolutions assures a more accurate time.) Divide by two and compare to time in table 24. Seconds in table 24 are based on a 1 cu.ft. dial and gas value of 1000 btu/ft³ for natural and 2500 btu/ft³ for LP. Adjust manifold pressure on gas valve to match time needed.

NOTE - To obtain accurate reading, shut off all other gas appliances connected to meter.

TABLE 24

Unit Input Rate	Seconds for Natural	Seconds for Propane
65,000	55	138
105,000	34	86
108,000	33	83
150,000	24	60

⚠ IMPORTANT

Disconnect heating demand as soon as an accurate reading has been obtained.

6-Heat Exchanger

To Access or Remove Heat Exchanger From Unit:

- 1- Turn off gas and electric power.
- 2- Remove access panel(s) and unit center mullion.
- 3- Remove gas valve, manifold assembly and burners.
- 4- Remove combustion air inducer. Pay careful attention to the order in which gaskets and orifice are removed.
- 5- Support heat exchanger (to prevent it from falling when final screws are removed.)
- 6- Remove screws supporting heat exchanger.
- 7- To install heat exchanger, reverse procedure. Be sure to secure all wires and check plumbing and burner plate for airtight seal. Screws must be torqued to 35 in.-lbs. to ensure proper operation.

7-Flame Sensing

Flame current is an electrical current which passes from the ignition control through the sensor electrode during unit operation. The current passes from the sensor through the flame to the ground electrode (located on the flame electrode) to complete a safety circuit. The electrodes should be located so the tips are at least 1/2" (12.7 mm) inside the flame envelope. Do not bend electrodes. To measure flame current, follow the procedure on the following page:

NOTE-Electrodes are not field adjustable. Any alterations to the electrode may create a hazardous condition that can cause property or personal injury.

- 1- Disconnect power to unit.

- 2- Remove lead from sensing electrode and install a 0-50DC microamp meter in series between the sensing electrode and the sensing lead.
- 3- Reconnect power and adjust thermostat for heating demand.
- 4- When flame is established, microamp reading should be 0.5 to 1.0. Do not bend electrodes.
Drop out signal is .09 or less.
- 5- Disconnect power to unit before disconnecting meter. Make sure sensor wire is securely reconnected before reconnecting power to unit.

NOTE-If the meter scale reads 0, the leads are reversed. Disconnect power and reconnect leads for proper polarity.

B-Cooling System Service Checks

KGB units are factory charged and require no further adjustment; however, charge should be checked periodically using the approach method. The approach method compares actual liquid temperature with the outdoor ambient temperature. See section IV- CHARGING.

VI-MAINTENANCE

The unit should be inspected once a year by a qualified service technician.

⚠ WARNING

Electric shock hazard. Can cause injury or death. Before attempting to perform any service or maintenance, turn the electrical power to unit OFF at disconnect switch(es). Unit may have multiple power supplies.

⚠ CAUTION

Label all wires prior to disconnection when servicing controls. Wiring errors can cause improper and dangerous operation. Verify proper operation after servicing.

A-Filters

Units are equipped with temporary filters which must be replaced prior to building occupation. See table 25 for correct filter size. Refer to local codes or appropriate jurisdiction for approved filters. Approved filters should be checked monthly and replaced when necessary. Take note of air flow direction marking on filter frame when reinstalling filters

TABLE 25

Unit	Qty	Filter Size - inches (mm)
024, 030, 036, 048	4	16 X 20 X 2 (406 X 508 X 51)
072, 060, 090	4	20 X 20 X 2 (508 X 508 X 51)

NOTE-Filters must be U.L.C. certified or equivalent for use in Canada.

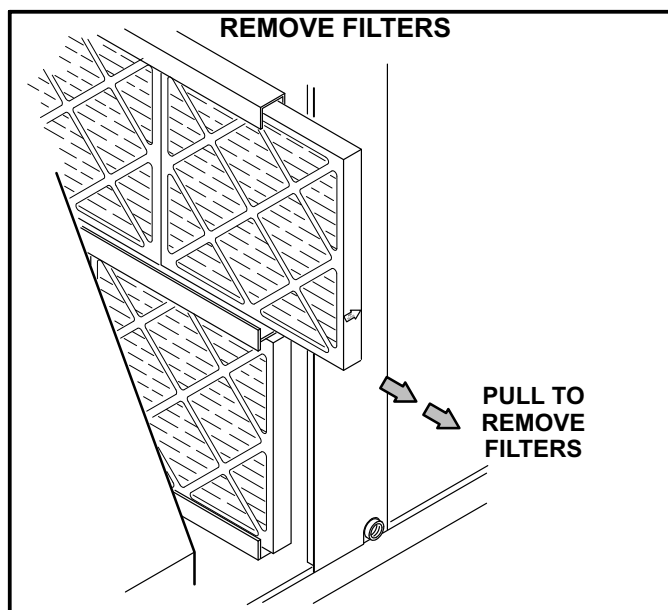

FIGURE 23

B-Lubrication

All motors are lubricated at the factory. No further lubrication is required.

C-Burners

Periodically examine burner flames for proper appearance during the heating season. Before each heating season examine the burners for any deposits or blockage which may have occurred.

Clean burners as follows:

- 1- Turn off both electrical power and gas supply to unit.
- 2- Remove burner compartment access panel.
- 3- Remove top burner box panel.
- 4- Remove two screws securing burners to burner support and lift the burners from the orifices. See figure 17. Clean as necessary.

⚠ WARNING

Danger of explosion. Can cause injury or death. Do not overtighten main burner mounting screws. Snug tighten only.

D-Combustion Air Inducer

A combustion air proving switch checks combustion air inducer operation before allowing power to the gas controller. Gas controller will not operate if inducer is obstructed.

Under normal operating conditions, the combustion air inducer wheel should be checked and cleaned prior to the heating season. However, it should be examined periodically during the heating season to establish an ideal cleaning schedule.

Clean combustion air inducer as follows:

- 1- Shut off power supply and gas to unit.
- 2- Remove the mullion on the right side of the heat section.
- 3- Disconnect pressure switch air tubing from combustion air inducer port.
- 4- Remove and retain screws securing combustion air inducer to flue box. Remove vent connector. See figure 16.
- 5- Clean inducer wheel blades with a small brush and wipe off any dust from housing. Take care not to damage exposed fan blades. Clean accumulated dust from front of flue box cover.
- 6- Return combustion air inducer motor and vent connector to original location and secure with retained screws. It is recommended that gaskets be replaced during re-assembly.
- 7- Replace mullion.
- 8- Clean combustion air inlet louvers on heat access panel using a small brush.

E-Flue Passageway and Flue Box

Remove flue box cover only when necessary for equipment repair. Clean inside of flue box cover and heat exchanger tubes with a wire brush when flue box cover has to be removed. Install a new flue box cover gasket and replace cover. Make sure edges around flue box cover are tightly sealed.

F-Supply Blower Wheel

Annually inspect supply air blower wheel for accumulated dirt or dust. Turn off power before attempting to remove access panel or to clean blower wheel.

G-Evaporator Coil

Inspect and clean coil at beginning of each cooling season. Clean using mild detergent or commercial coil cleanser. Flush coil and condensate drain with water taking care not to get insulation, filters and return air ducts wet.

H-Condenser Coil

All-Aluminum Environ Coils

Clean condenser coil annually with water and inspect monthly during the cooling season.

Clean the all-aluminum coil by spraying the coil steadily and uniformly from top to bottom. Do not exceed 900 psi or a 45° angle; nozzle must be at least 12 inches from the coil face. Take care not to fracture the braze between the fins and refrigerant tubes. Reduce pressure and work cautiously to prevent damage.

VII-ACCESSORIES

The accessories section describes the application of most of the optional accessories which can be factory or field installed to the KGB units.

A-T1CURB / K1CURB

When installing the KGB units on a combustible surface for downflow discharge applications, the T1CURB / K1CURB 8 inch, 14-inch, 18 inch or 24-inch height roof mounting frame is used. The roof mounting frames are recommended in all other applications but not required. If the KGB units are not mounted on a flat (roof) surface, they MUST be supported under all edges and under the middle of the unit to prevent sagging. The units MUST be mounted level within 1/16" per linear foot or 5mm per meter in any direction.

The assembled mounting frame is shown in figure 24. Refer to the roof mounting frame installation instructions for details of proper assembly and mounting. The roof mounting frame MUST be squared to the roof and level before mounting. Plenum system MUST be installed before the unit is set on the mounting frame. Typical roof curbing and flashing is shown in figure 25. Refer to the roof mounting frame installation instructions for proper plenum construction and attachment.

B-Transitions

Optional supply/return transitions T1TRAN10AN1 is available for use with the KGB 2, 2.5, 3, 4 and 5 units and the T1TRAN20N-1 is available for the 6 and 7-1/2 ton units utilizing optional K1CURB roof mounting frames. Transition must be installed in the K1CURB mounting frame before mounting the unit to the frame. Refer to the manufacturer's instructions included with the transition for detailed installation procedures.

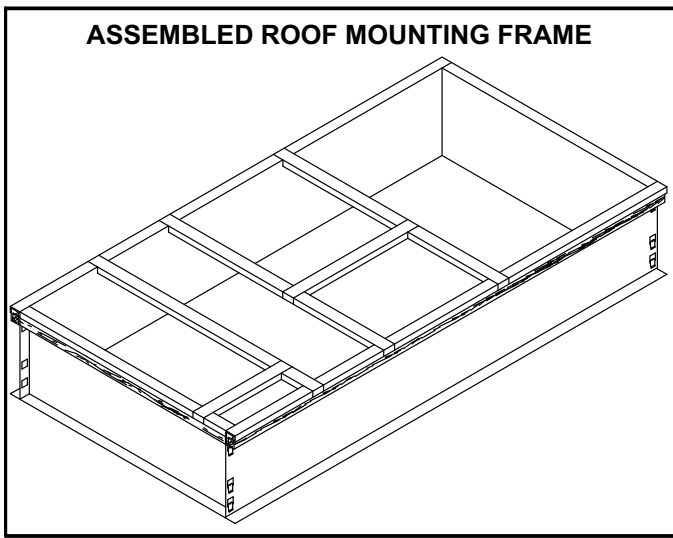

FIGURE 24

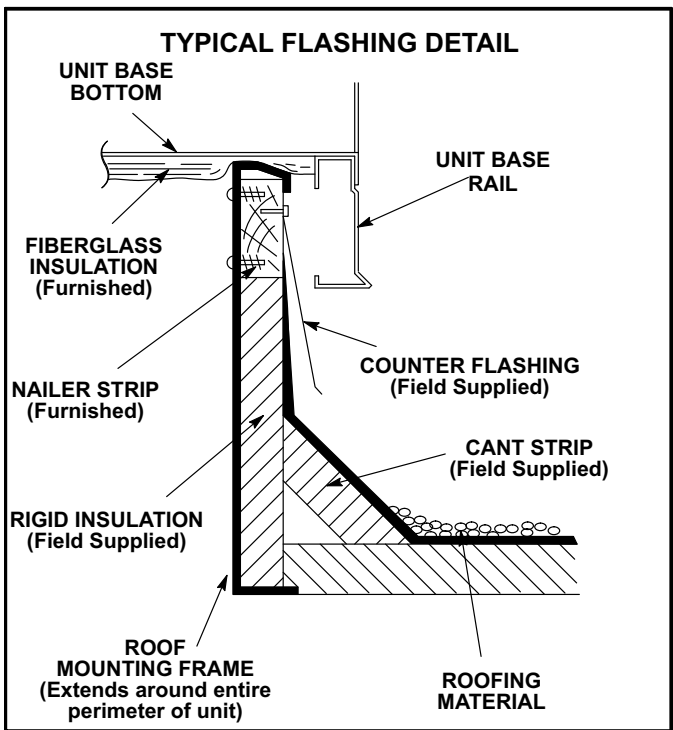

FIGURE 25

C-Outdoor Air Dampers

T1DAMP11A-1 is available for KGA 2, 2.5, 3, 4 and 5 ton unit and T1DAMP11N-1 is available for the KGA/KGB 6 and 7-1/2 ton units. Both sets include the outdoor air hood. A motorized kit (T1DAMP21AN1) can be ordered separately for all KGB unit sizes. The dampers may be manually or motor (M) operated to allow up to 25 percent outside air into the system at all times (see figure 26). Washable filter supplied with the outdoor air dampers can be cleaned with water and a mild detergent. It should be sprayed with Filter Handicoater when dry prior to re-installation. Filter Handicoater is R.P. Products coating no. 418 and is available as Part No. P-8-5069.

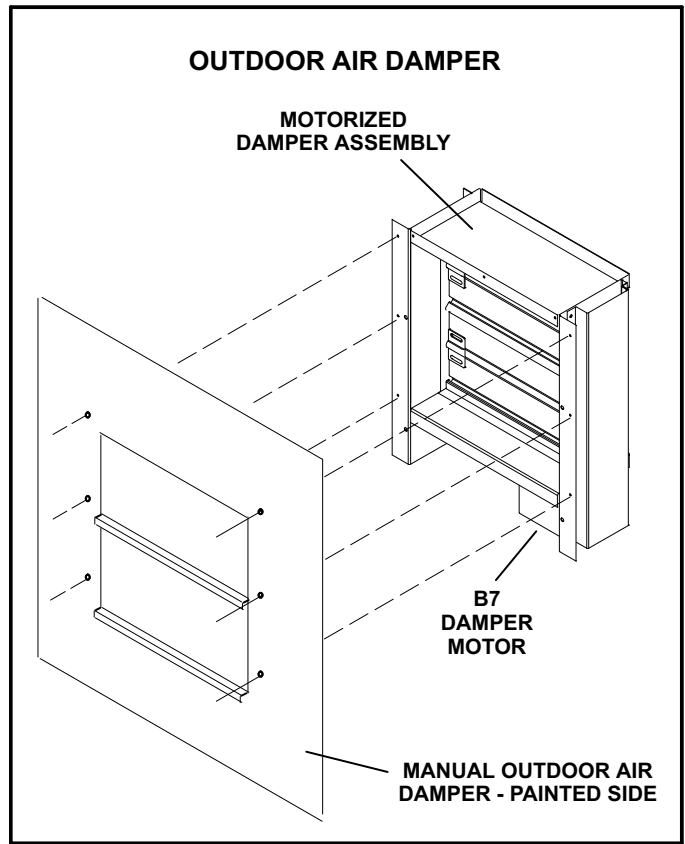

FIGURE 26

D-Supply and Return Diffusers (all units)

Optional flush mount diffuser/return FD9-65 and FD11-95 and extended mount diffuser/return RTD9-65 and RTD11-95 are available for use with all KGB units. Refer to manufacturer's instructions included with transition for detailed installation procedures.

E-Economizer

(Field or Factory Installed)

Unit may contain an optional factory-installed economizer equipped with an A6 enthalpy control and an A7 outdoor enthalpy sensor. The modulating economizer opens fully to use outdoor air for free cooling when temperature is suitable and opens to minimum position during the occupied time period.

The A6 enthalpy control is located in the economizer access area. See figure 27. The A7 enthalpy sensor is located on the division panel between horizontal supply and return air sections.

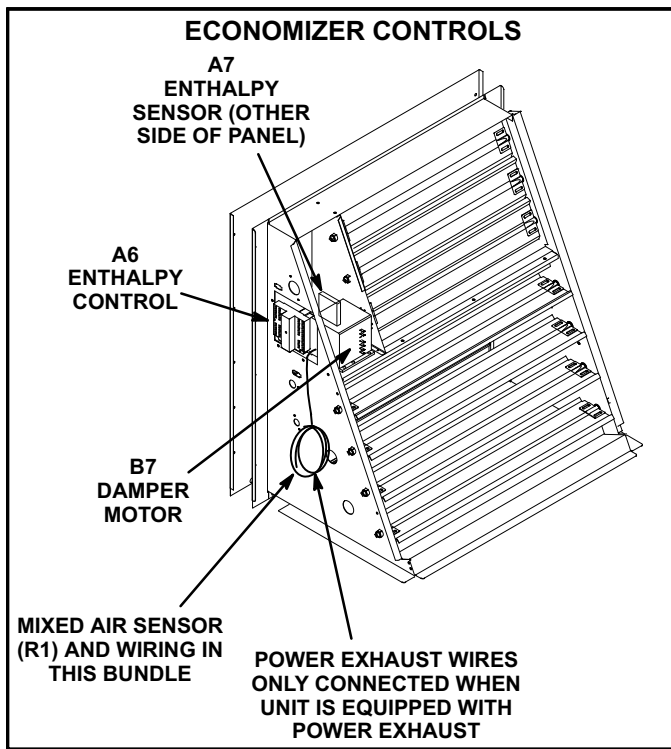

FIGURE 27

Optional Sensors

An optional differential sensor (A62) may be used with the A7 outdoor sensor to compare outdoor air enthalpy to return air enthalpy. When the outdoor air enthalpy is below the return air enthalpy, outdoor air is used for free cooling.

Mixed air sensor (R1) may be used to modulate dampers to 55°F (13°C) discharge air.

An optional IAQ sensor (A63) may be used to lower operating costs by controlling outdoor air based on CO₂ level or room occupancy (also called demand control ventilation or DCV). Damper minimum position can be set lower than traditional minimum air requirements; dampers open to traditional ventilation requirements when CO₂ level reaches DCV (IAQ) setpoint.

Refer to instructions provided with sensors for installation.

A6 Enthalpy Control LEDs

A steady green Free Cool LED indicates that outdoor air is suitable for free cooling.

When an optional IAQ sensor is installed, a steady green DCV LED indicates that the IAQ reading is higher than setpoint requiring more fresh air. See figure 28.

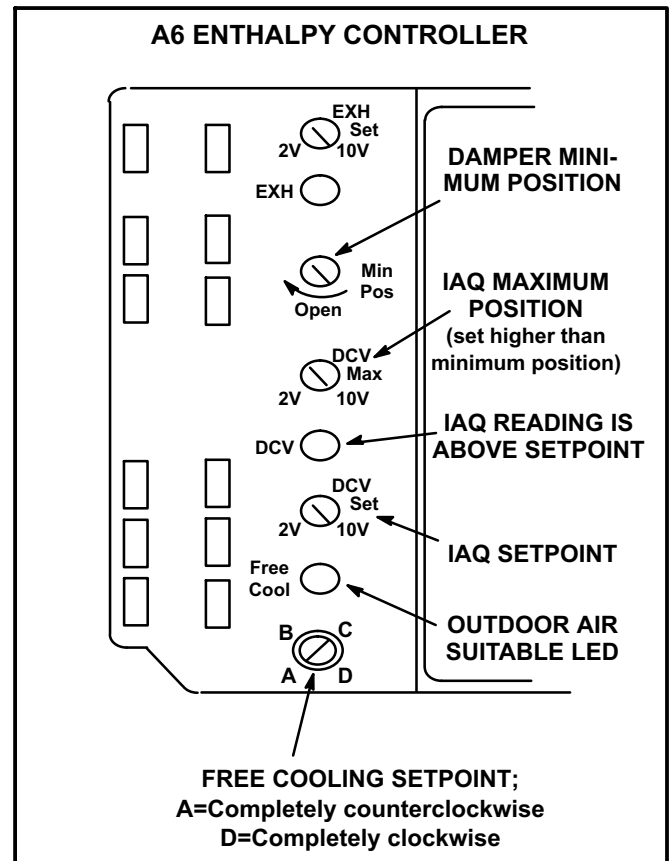

FIGURE 28

Free Cooling Setpoint

Outdoor air is considered suitable when temperature and humidity are less than the free cooling setpoints shown in table 26. Setting A is recommended. See figure 28. At setting A, free cooling will be energized when outdoor air is approximately 73°F (23°C) and 50% relative humidity. If indoor air is too warm or humid, lower the setpoint to B. At setting B, free cooling will be energized at 70°F (21°C) and 50% relative humidity.

When an optional A62 differential sensor is installed, turn A6 enthalpy control free cooling setpoint potentiometer completely clockwise to position "D".

TABLE 26
ENTHALPY CONTROL SETPOINTS

Control Setting	Free Cooling Setpoint At 50% RH
A	73° F (23° C)
B	70° F (21° C)
C	67° F (19° C)
D	63° F (17° C)

Damper Minimum Position

NOTE - A jumper is factory-installed between TB1 R and OC terminals to maintain occupied status (allowing minimum fresh air). When using an electronic thermostat or energy management system with an occupied/unoccupied feature, remove jumper.

- 1- Set thermostat to occupied mode if the feature is available. Make sure jumper is in place between TB1 terminals R and OC if using a thermostat which does not have the feature.
- 2- Rotate MIN POS SET potentiometer to approximate desired fresh air percentage.

Note - Damper minimum position can be set lower than traditional minimum air requirements when an IAQ sensor is specified. Dampers will open to DCV MAX setting (if CO₂ is above setpoint) to meet traditional ventilation requirements.

- 3- Measure outdoor air temperature. Mark the point on the bottom line of chart 1 and label the point "A" (40°F, 4°C shown).
- 4- Measure return air temperature. Mark that point on the top line of chart 1 and label the point "B" (74°F, 23°C shown).
- 5- Measure mixed air (outdoor and return air) temperature. Mark that point on the top line of chart 1 and label point "C" (70°F, 21°C shown).
- 6- Draw a straight line between points A and B.
- 7- Draw a vertical line through point C.

- 8- Draw a horizontal line where the two lines meet. Read the percent of fresh air intake on the side.
- 9- If fresh air percentage is less than desired, adjust MIN POS SET potentiometer higher. If fresh air percentage is more than desired, adjust MIN POS SET potentiometer lower. Repeat steps 3 through 8 until calculation reads desired fresh air percentage.

DCV Set and Max Settings

Adjust settings when an optional IAQ sensor is installed.

The DCV SET potentiometer is factory-set at approximately 50% of the potentiometer range. Using a standard 1-2000ppm CO₂ sensor, dampers will start to open when the IAQ sensor reads approximately 1000ppm. Adjust the DCV SET potentiometer to the approximate setting specified by the controls contractor. Refer to figure 28.

The DCV MAX potentiometer is factory-set at approximately 50% of the potentiometer range or 6VDC. Dampers will open approximately half way when CO₂ rises above setpoint. Adjust the DCV MAX potentiometer to the approximate setting specified by the controls contractor. Refer to figure 28.

Note - DCV Max must be set higher than economizer minimum position setting for proper demand control ventilation.

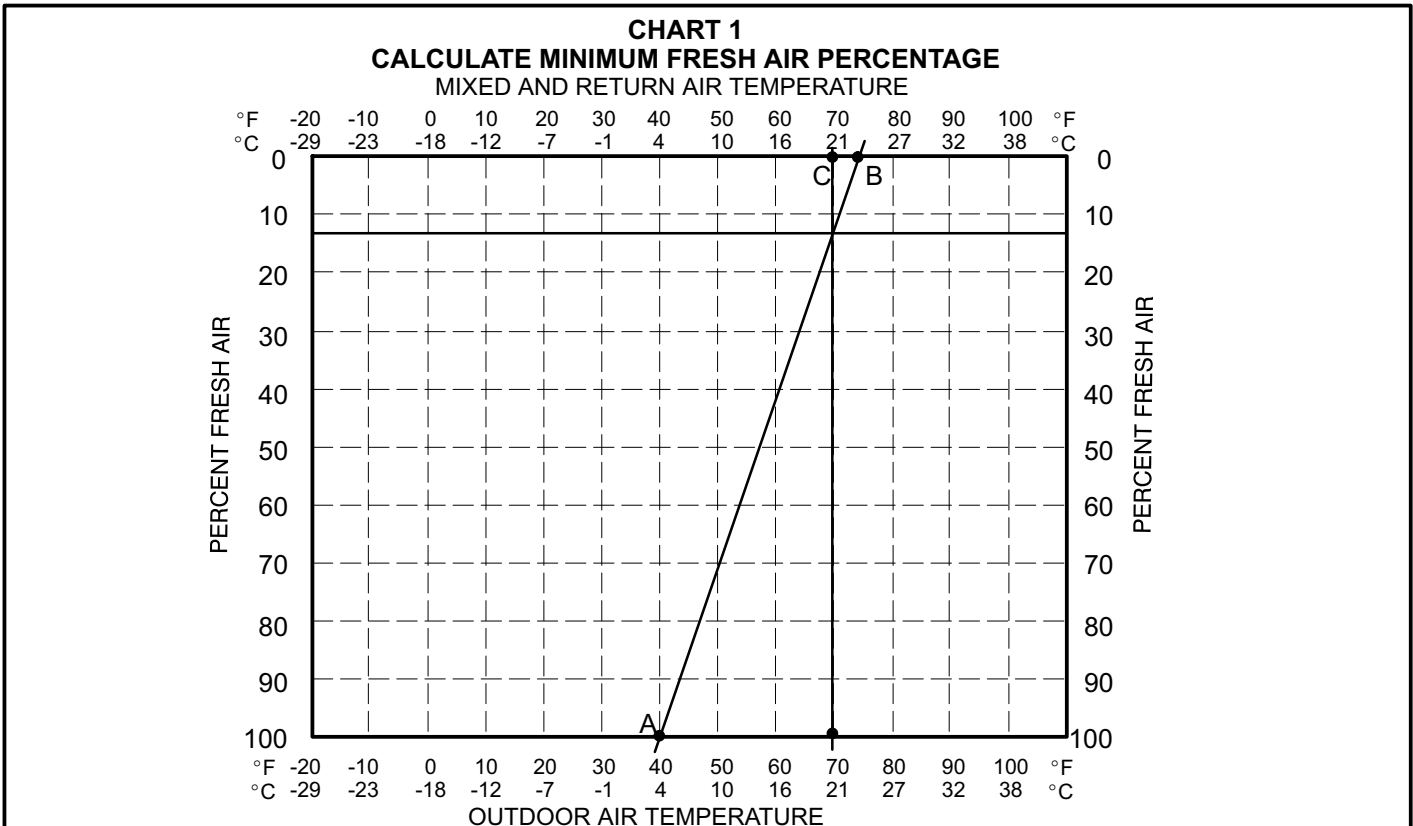

Economizer Operation

The occupied time period is determined by the thermostat or energy management system.

Outdoor Air Not Suitable:

During the unoccupied time period dampers are closed.

During the occupied time period a cooling demand will open dampers to minimum position and mechanical cooling functions normally.

During the occupied time period dampers will open to DCV MAX when IAQ reading is above setpoint (regardless of thermostat demand or outdoor air suitability).

Outdoor Air Suitable:

See table 27 for economizer operation with a standard two-stage thermostat.

During the occupied period, dampers will open to DCV MAX when IAQ reading is above setpoint (regardless of thermostat demand or outdoor air suitability). DCV MAX will NOT override damper full-open position. When an R1 mixed air sensor for modulating dampers is installed, DCV MAX may override damper free cooling position when occupancy is high and outdoor air temperatures are low. If R1 senses discharge air temperature below 45°F (7°C), dampers will move to minimum position until discharge air temperature rises to 48°F (9°C).

B-Outdoor Air Dampers

Optional manual and motorized outdoor air dampers provide fresh outdoor air. The motorized damper assembly opens to minimum position during the occupied time period and remains closed during the unoccupied period. Manual damper assembly is set at installation and remains in that position.

Set damper minimum position in the same manner as economizer minimum position. Adjust motorized damper position using the thumbwheel on the damper motor. See figure 29. Manual damper fresh air intake percentage can be determined in the same manner.

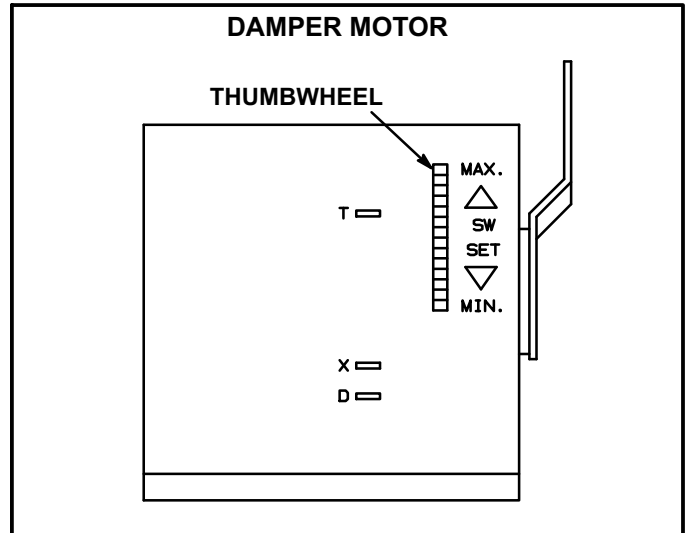

FIGURE 29

F-Power Exhaust Relay K65 (power exhaust units)

Power exhaust relay K65 is a DPDT relay with a 24VAC coil. K65 is used in all KGB units equipped with the optional power exhaust dampers. K65 is energized by the economizer enthalpy control A6, after the economizer dampers reach 50% open (adjustable) When K65 closes, exhaust fan B10 is energized.

G-Power Exhaust Fans

T1PWRE10A available for KGB 3, 4 and 5 ton units and T1PWRE10N available for 6 and 7-1/2 ton units, provide exhaust air pressure relief and also run when return air dampers are closed and supply air blowers are operating. See figure 30 and installation instructions for more detail.

TABLE 27
ECONOMIZER OPERATION

OUTDOOR AIR IS SUITABLE FOR FREE COOLING – FREE COOL LED “ON”

THERMOSTAT DEMAND	DAMPER POSITION		MECHANICAL COOLING
	UNOCCUPIED	OCCUPIED	
OFF	CLOSED	CLOSED	NO
G	CLOSED	MINIMUM	NO
Y1	OPEN*	OPEN*	NO
Y2	OPEN*	OPEN*	STAGE 1

*Dampers will modulate to maintain 55°F (13°C) supply air when an R1 mixed air sensor is installed.

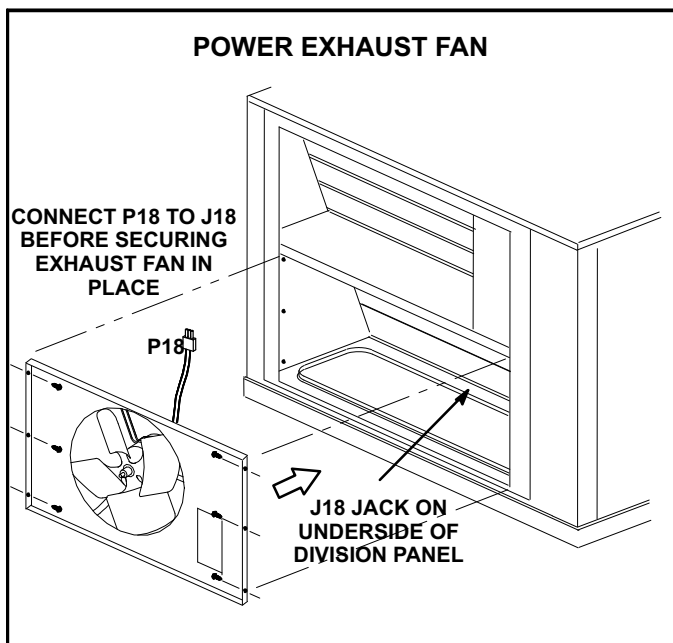

FIGURE 30

H-Optional Cold Weather Kit

Electric heater is available to automatically control the minimum temperature in the gas burner compartment. Heater is C.S.A. certified to allow cold weather operation of unit down to -60°F (-50°C).

The kit includes the following parts:

- 1- The strip heater (HR6) is located as close as possible to the gas valve. The strip heater is rated at 500 Watts
- 2- A thermostat mounting box is installed on the wall of the compressor compartment. Included in the box are the following thermostat switches:
 - a - Thermostat switch (S59) is an auto-reset SPST N.C. switch which opens on a temperature drop. The switch is wired in series with 24v power and the combustion air blower switch. When the temperature drops below -30°F (-35°C) the switch opens and the gas heat section is de-energized. The switch automatically resets when the heating compartment temperature reaches -10°F (-12°C).
 - b - Thermostat switch (S60) is an auto-reset SPST N.C. switch which opens on a temperature rise. The switch is wired in series with HR6. When the temperature rises above 20°F (-7°C) the switch opens and the electric heater is de-energized. The switch automatically resets when the heating compartment temperature reaches -10°F (23.3°C).
 - c - Thermostat switch (S61) is an auto-reset SPST N.O. switch which closes on a temperature drop. The switch is wired in series with HR6. When temperature drops below 20°F (-7°C) the switch closes and electric heater is energized. The switch automatically opens when heating compartment temperature reaches 70°F (21°C).

I-Control Systems

Three different types of control systems may be used with the KGB series units. All thermostat wiring is connected to TB1 located in the control box. Each thermostat has additional control options available. See thermostat installation instructions for more detail.

- 1- Electro-mechanical thermostat (13F06)
The electro-mechanical thermostat is a two stage heat / two stage cool thermostat with dual temperature levers. A non-switching or manual system switch subbase may be used.
- 2- Electronic thermostat (see price book)
Any two stage heat / two stage cool electronic thermostat may be used.
- 3- Honeywell T7300 thermostat (60L59)
The Honeywell T7300 thermostat is a programmable, internal or optional remote temperature sensing thermostat. The T7300 provides occupied and unoccupied changeover control.

J-Smoke Detectors A17 and A64

Photoelectric smoke detectors are a field installed option. The smoke detectors can be installed in the supply air duct (A64), return air section (A17), or in both the supply duct and return air section.

K-Dirty Filter Switch S27

The dirty filter switch senses static pressure increase indicating a dirty filter condition. The switch is N.O. and closes at $1''\text{ W.C.}$ (248.6 Pa) The switch is mounted in the filter section on the left unit mullion.

L-Indoor Air Quality (CO₂) Sensor A63

The indoor air quality sensor monitors CO₂ levels and reports the levels to the economizer enthalpy control A6. Controller A6 adjusts the economizer dampers according to the CO₂ levels. The sensor is mounted next to the indoor thermostat or in the return air duct. Refer to the indoor air quality sensor installation instructions for proper adjustment.

M-LP / Propane Kit

All units require a natural to LP /propane kit. The kit for single stage units include one LP spring , seven burner orifices, and three stickers. Two stage kits include the same but has a prove switch used to lock out first stage on the combustion air inducer. For more detail refer to the natural to LP gas changeover kit installation instructions.

N-Drain Pan Overflow Switch S149 (optional)

The overflow switch is used to interrupt cooling operation when excessive condensate collects in the drain pan. The N.O. overflow switch is controlled by K220 and DL46 relays, located in the unit control panel. When the overflow switch closes, 24VAC power is interrupted and after a five-second delay unit compressors are de-energized. Once the condensate level drops below the set level, the switch will open. After a five-minute delay the compressor will be energized.

VIII-Wiring Diagrams and Sequence of Operation

KGB024/060 P VOLTAGE UNIT DIAGRAM

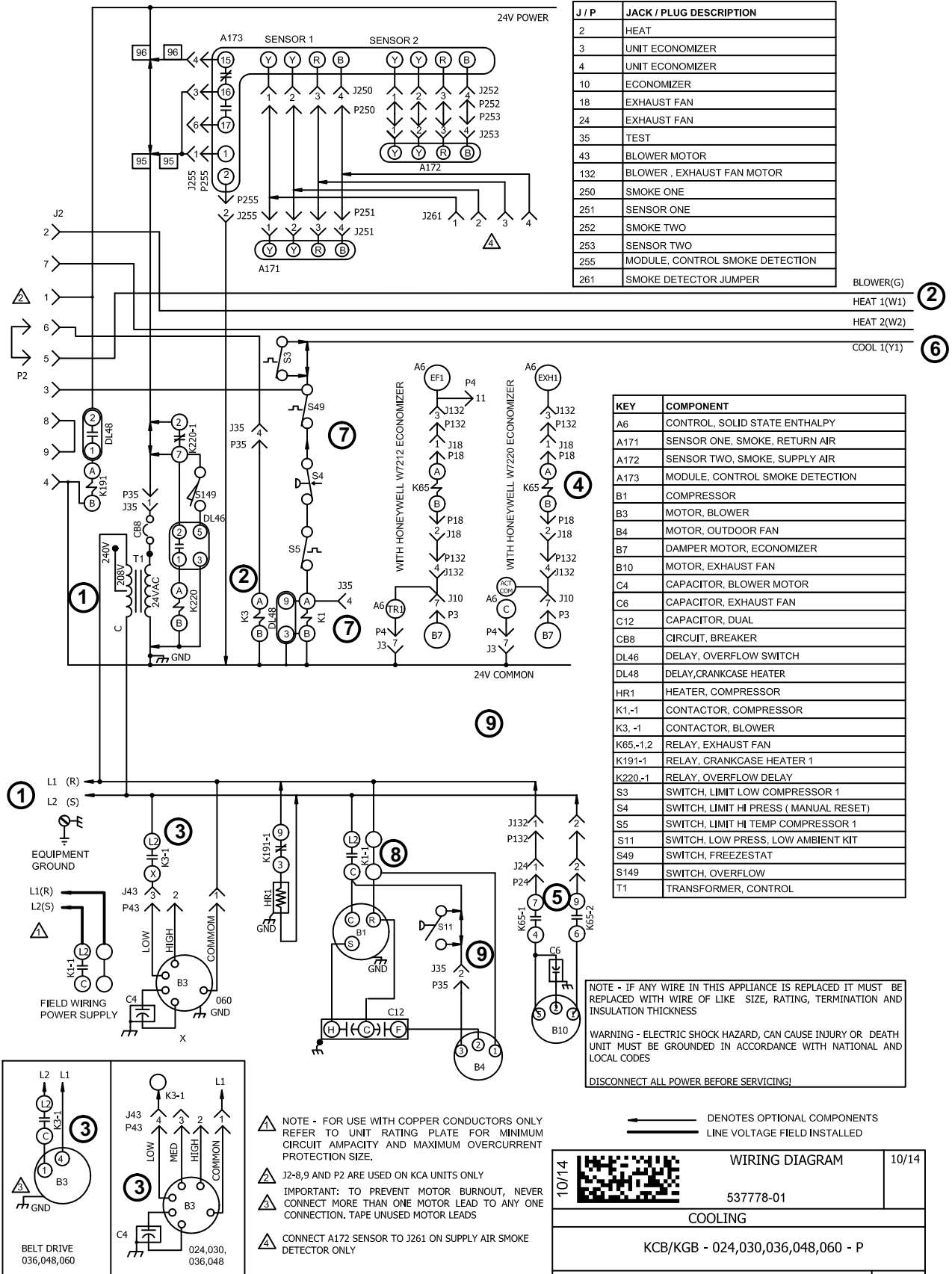

J / P	JACK / PLUG DESCRIPTION
2	HEAT
3	UNIT ECONOMIZER
4	UNIT ECONOMIZER
10	ECONOMIZER
18	EXHAUST FAN
24	EXHAUST FAN
35	TEST
43	BLOWER MOTOR
132	BLOWER , EXHAUST FAN MOTOR
250	SMOKE ONE
251	SENSOR ONE
252	SMOKE TWO
253	SENSOR TWO
255	MODULE, CONTROL SMOKE DETECTION
261	SMOKE DETECTOR JUMPER

KEY	COMPONENT
A6	CONTROL, SOLID STATE ENTHALPY
A171	SENSOR ONE, SMOKE, RETURN AIR
A172	SENSOR TWO, SMOKE, SUPPLY AIR
A173	MODULE, CONTROL SMOKE DETECTION
B1	COMPRESSOR
B3	MOTOR, BLOWER
B4	MOTOR, OUTDOOR FAN
B7	DAMPER MOTOR, ECONOMIZER
B10	MOTOR, EXHAUST FAN
C4	CAPACITOR, BLOWER MOTOR
C6	CAPACITOR, EXHAUST FAN
C12	CAPACITOR, DUAL
CB8	CIRCUIT, BREAKER
DL46	DELAY, OVERFLOW SWITCH
DL48	DELAY, CRANKCASE HEATER
HR1	HEATER, COMPRESSOR
K1,-1	CONTACTOR, COMPRESSOR
K3,-1	CONTACTOR, BLOWER
K65,-1,2	RELAY, EXHAUST FAN
K191-1	RELAY, CRANKCASE HEATER 1
K220,-1	RELAY, OVERFLOW DELAY
S3	SWITCH, LIMIT LOW COMPRESSOR 1
S4	SWITCH, LIMIT HI PRESS (MANUAL RESET)
S5	SWITCH, LIMIT HI TEMP COMPRESSOR 1
S11	SWITCH, LOW PRESS, LOW AMBIENT KIT
S49	SWITCH, FREEZESTAT
S149	SWITCH, OVERFLOW
T1	TRANSFORMER, CONTROL

NOTE - IF ANY WIRE IN THIS APPLIANCE IS REPLACED IT MUST BE REPLACED WITH WIRE OF LIKE SIZE, RATING, TERMINATION AND INSULATION THICKNESS

WARNING - ELECTRIC SHOCK HAZARD, CAN CAUSE INJURY OR DEATH UNIT MUST BE GROUNDED IN ACCORDANCE WITH NATIONAL AND LOCAL CODES

DISCONNECT ALL POWER BEFORE SERVICING!

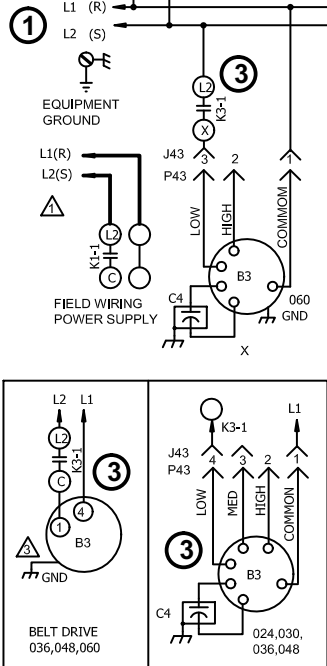

- ⚠ NOTE - FOR USE WITH COPPER CONDUCTORS ONLY REFER TO UNIT RATING PLATE FOR MINIMUM CIRCUIT AMPACITY AND MAXIMUM OVERCURRENT PROTECTION SIZE.
- ⚠ J2-8,9 AND P2 ARE USED ON KCA UNITS ONLY
- ⚠ IMPORTANT: TO PREVENT MOTOR BURNOUT, NEVER CONNECT MORE THAN ONE MOTOR LEAD TO ANY ONE CONNECTION. TAPE UNUSED MOTOR LEADS
- ⚠ CONNECT A172 SENSOR TO J261 ON SUPPLY AIR SMOKE DETECTOR ONLY

← DENOTES OPTIONAL COMPONENTS
 — LINE VOLTAGE FIELD INSTALLED

10/14	WIRING DIAGRAM	10/14
537778-01		
COOLING		
KCB/KGB - 024,030,036,048,060 - P		
SECTION B		REV 0
Supersedes 537631-01	New Form No. 537778-01	

KGB036/090 G, J, M & Y VOLTAGE UNIT DIAGRAM

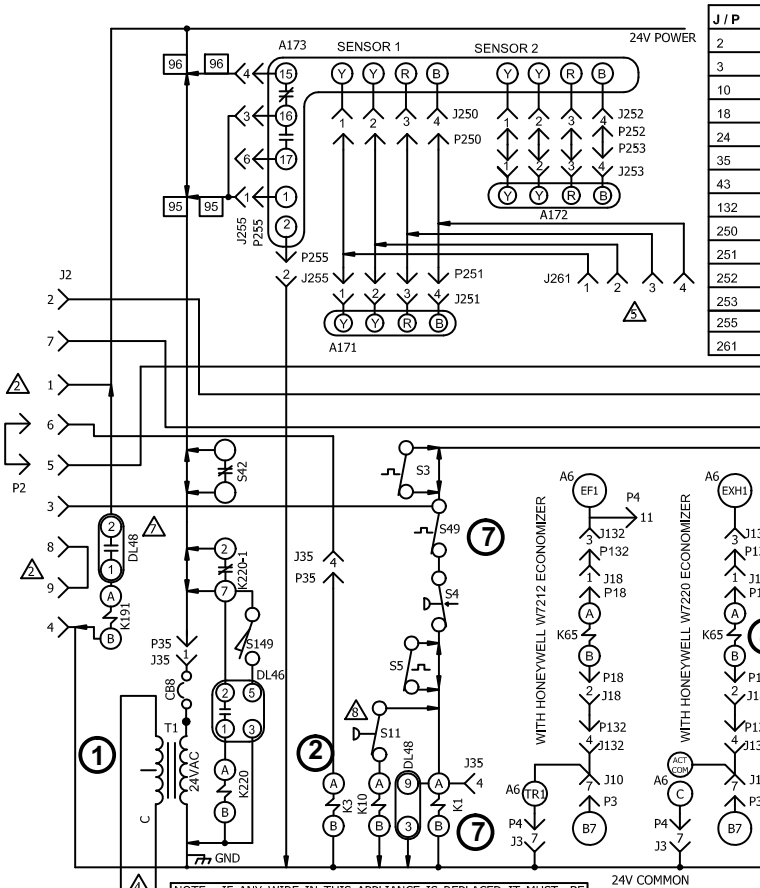

J / P	JACK / PLUG DESCRIPTION
2	HEAT
3	UNIT ECONOMIZER
10	ECONOMIZER
18	EXHAUST FAN
24	EXHAUST FAN
35	TEST
43	BLOWER MOTOR
132	BLOWER , EXHAUST FAN MOTOR
250	SMOKE ONE
251	SENSOR ONE
252	SMOKE TWO
253	SENSOR TWO
255	MODULE, CONTROL SMOKE DETECTION
261	SMOKE DETECTOR JUMPER

BLOWER(G) **2**
 HEAT 1(W1) **6**
 HEAT 2(W2)
 COOL 1(Y1)

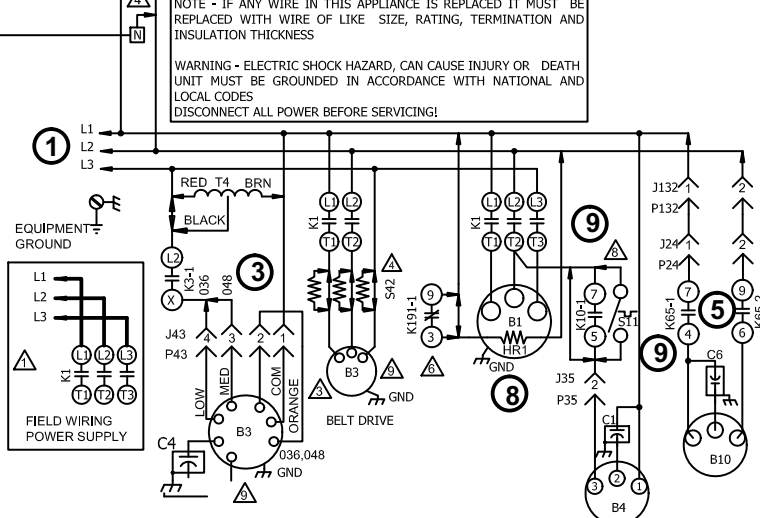

NOTE - IF ANY WIRE IN THIS APPLIANCE IS REPLACED IT MUST BE REPLACED WITH WIRE OF LIKE SIZE, RATING, TERMINATION AND INSULATION THICKNESS

WARNING - ELECTRIC SHOCK HAZARD, CAN CAUSE INJURY OR DEATH UNIT MUST BE GROUNDED IN ACCORDANCE WITH NATIONAL AND LOCAL CODES

DISCONNECT ALL POWER BEFORE SERVICING!

KEY	COMPONENT
A6	CONTROL, SOLID STATE ENTHALPY
A171	SENSOR ONE, SMOKE, RETURN AIR
A172	SENSOR TWO, SMOKE, SUPPLY AIR
A173	MODULE, CONTROL SMOKE DETECTION
B1	COMPRESSOR
B3	MOTOR, BLOWER
B4	MOTOR, OUTDOOR FAN
B7	DAMPER MOTOR, ECONOMIZER
B10	MOTOR, EXHAUST FAN
C1	CAPACITOR, OUTDOOR FAN
C4	CAPACITOR, BLOWER MOTOR
C6	CAPACITOR, EXHAUST FAN
CB8	CIRCUIT, BREAKER
DL46	DELAY, OVERFLOW SWITCH
DL48	DELAY, CRANKCASE HEATER
HR1	HEATER, COMPRESSOR
K1-1	CONTACTOR, COMPRESSOR
K3-1	CONTACTOR, BLOWER
K10-1	RELAY, OUTDOOR FAN 1
K65-1,2	RELAY, EXHAUST FAN
K191-1	RELAY, CRANKCASE HEATER 1
K220-1	RELAY, OVERFLOW DELAY
S3	SWITCH, LIMIT LOW COMPRESSOR 1
S4	SWITCH, LIMIT HI PRESS (MANUAL RESET)
S5	SWITCH, LIMIT HI TEMP COMPRESSOR 1
S11	SWITCH, LOW PRESS, LOW AMBIENT KIT
S42	SWITCH, OVERLOAD RELAY BLOWER MOTOR
S49	SWITCH, FREEZESTAT
S149	SWITCH, OVERFLOW
T1	TRANSFORMER, CONTROL
T4	TRANSFORMER, BLOWER MOTOR

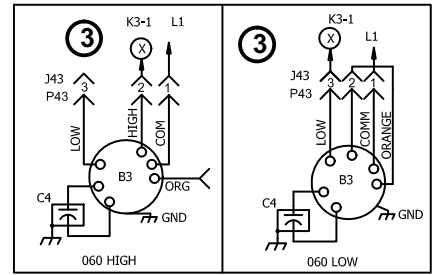

- ⚠ DL48, K191 FACTORY INSTALLED KC,GB 036,048,060
- ⚠ S11 OPTION - Y VOLT K10-1 OPTION G,J VOLT
- ⚠ SEE SECTION E DIAGRAMS FOR 2 - SPEED BELT DRIVE SYSTEMS

- ⚠ NOTE - FOR USE WITH COPPER CONDUCTORS ONLY REFER TO UNIT RATING PLATE FOR MINIMUM CIRCUIT AMPACITY AND MAXIMUM OVERCURRENT PROTECTION SIZE.
- ⚠ J2-8,9 AND P2 ARE USED ON KCA UNITS ONLY
- ⚠ IMPORTANT: TO PREVENT MOTOR BURNOUT, NEVER CONNECT MORE THAN ONE MOTOR LEAD TO ANY ONE CONNECTION. TAPE UNUSED MOTOR LEADS
- ⚠ S42, N USED ON M VOLT UNITS
- ⚠ CONNECT A172 SENSOR TO J261 ON SUPPLY AIR SMOKE DETECTOR ONLY
- ⚠ HR1 FIELD OPTION ON KCA/KGA 036,048,060

08/15		WIRING DIAGRAM	08/15
	537777-01		
COOLING			
KCA,B/KGA,B-036,048,060,072,074,090- G,J,M,Y			
SECTION B			REV. 1
Supersedes		New Form No.	
537630-01		537777-01	

⚡ DENOTES OPTIONAL COMPONENTS
 LINE VOLTAGE FIELD INSTALLED

KGB024/090 P, Y, G, J & M Voltage Sequence of Operation

Power:

1. Line voltage from unit disconnect energizes transformer T1. T1 provides 24VAC power to terminal strip TB1. TB1 provides 24VAC to the unit cooling, heating and blower controls.

Blower Operation:

2. Indoor thermostat terminal G energizes blower contactor K3 with 24VAC.
3. N.O. K3 closes, energizing blower B3.

Economizer Operation:

4. The economizer control module receives a demand and energizes exhaust fan relay K65 with 24VAC at 50% outside air damper open (adjustable).
5. N.O. K65-1 and N.O. K65-2 both close, energizing exhaust fan motor B10.

Cooling Demand

6. First stage cooling demand Y1 and G is energized by the thermostat. G energizes blower.
7. 24VAC is routed through TB1 to N.C. freezeestat S49, and optional N.C. high pressure switch S4. Compressor contactor K1 is energized.
8. N.O. K1-1 close energizing compressor B1.

9. **Single Phase P Voltage Units**

Optional N.O. low ambient switch S11 closes to energize condenser fan B4.

Three Phase Y Voltage Units

Optional N.O. low ambient switch S11 closes to energize condenser fan B4.

Three Phase G, J & M Voltage Units

Optional N.O. low ambient switch S11 closes to energize condenser fan relay K10.

N.O. contacts K10-1 close energizing condenser fan B4 .

KGB-074 Two-Stage Units

10. First-stage cooling demand Y1 and G is energized by the thermostat. G energizes blower.
11. *Following from step 7* K1 energizes compressor, condenser fan and blower B1 on low speed.
12. Second-stage cooling demand Y2 energizes compressor B1, condenser fan and blower B1 on high speed.

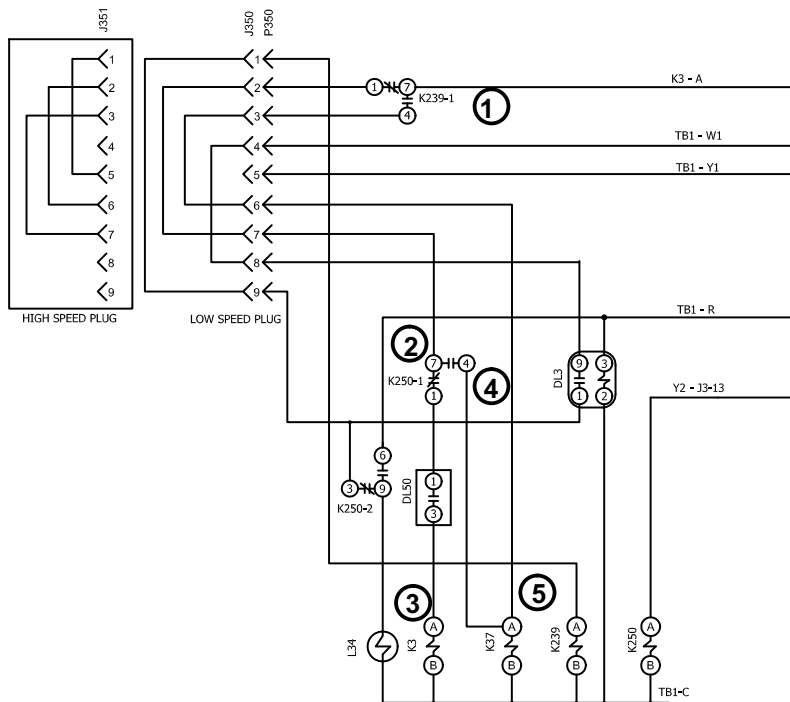

J / P	JACK / PLUG DESCRIPTION
350	BLOWER HI/LO MECHANICAL SWITCHING
351	BLOWER HI/LO MECHANICAL SWITCHING

KEY	COMPONENT
B3	MOTOR, BLOWER
DL3	DELAY, GAS 2.180 SEC DELAY ON BREAK
DL50	DELAY, 1.5 SEC. DELAY ON MAKE
K3, -1	CONTACTOR, BLOWER
K37	RELAY, BLOWER
K239	RELAY, Y1/W1 HI-LO SWITCHING RELAY
K250	RELAY, Y2 HIGH SPEED BLOWER
L34	SOLENOID, TWO STAGE COMPRESSOR

④ DENOTES OPTIONAL COMPONENTS
 LINE VOLTAGE FIELD INSTALLED

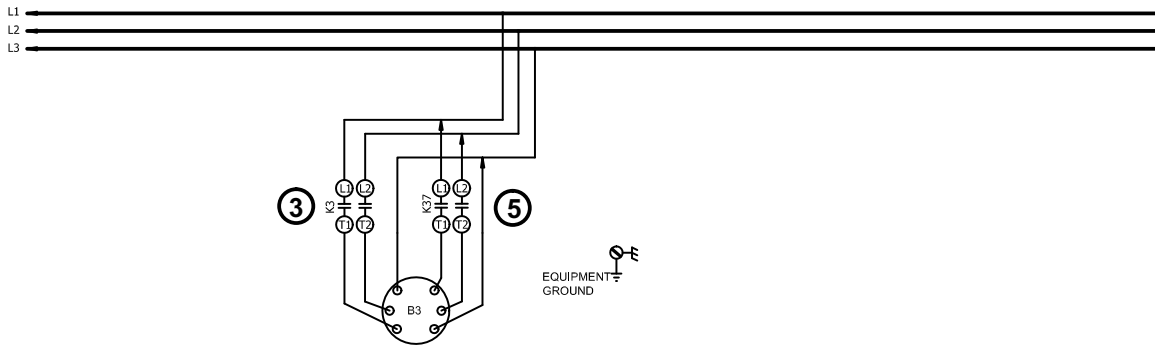

KGB-074 Two-Stage Units

1. **First-stage cooling demand Y1** and G is energized by the thermostat. G energizes blower.
2. Relay K239 directs voltage through relay K250 to energize contactor K3.
3. Blower contactor K3 energizes blower B3 on low speed.
4. **Second-stage cooling demand Y2** energizes relay K250 to redirect voltage to contactor K37
5. Contactor K37 energizes blower B3 on high speed.

08/15		WIRING DIAGRAM	08/15
		537822-01	
COOLING			
2 SPEED A - BOX AND A+ - BOX - G,J,M,Y			
SECTION E			REV. 0
Supersedes		New Form No. 537822-01	

GAS HEAT FOR KGB024/090 UNITS

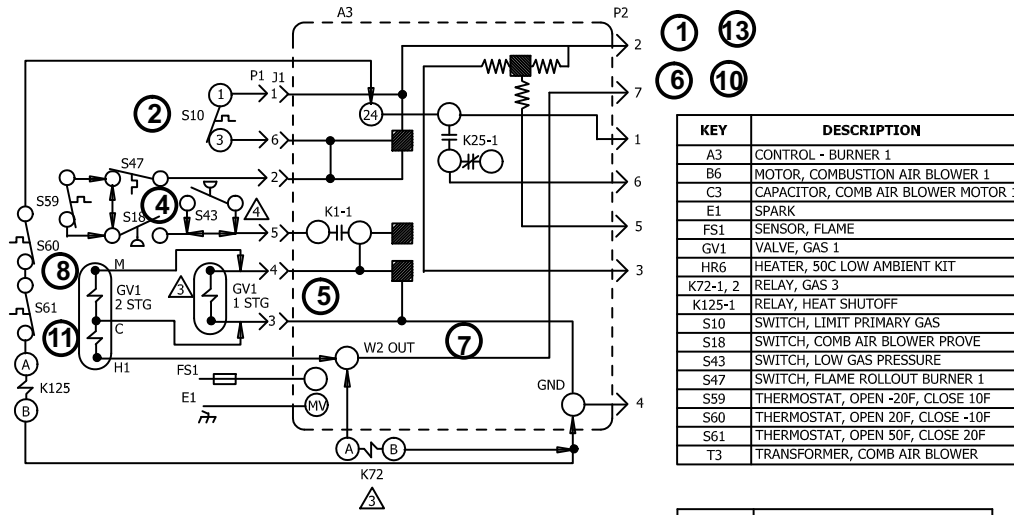

INDICATES MICRO PROCESSOR
 DENOTES OPTIONAL COMPONENTS

J/P	JACK/PLUG DESCRIPTION
1	GAS LIMIT
2	HEAT
19	COMB AIR BLOWER
21	COMB AIR BLOWER 2

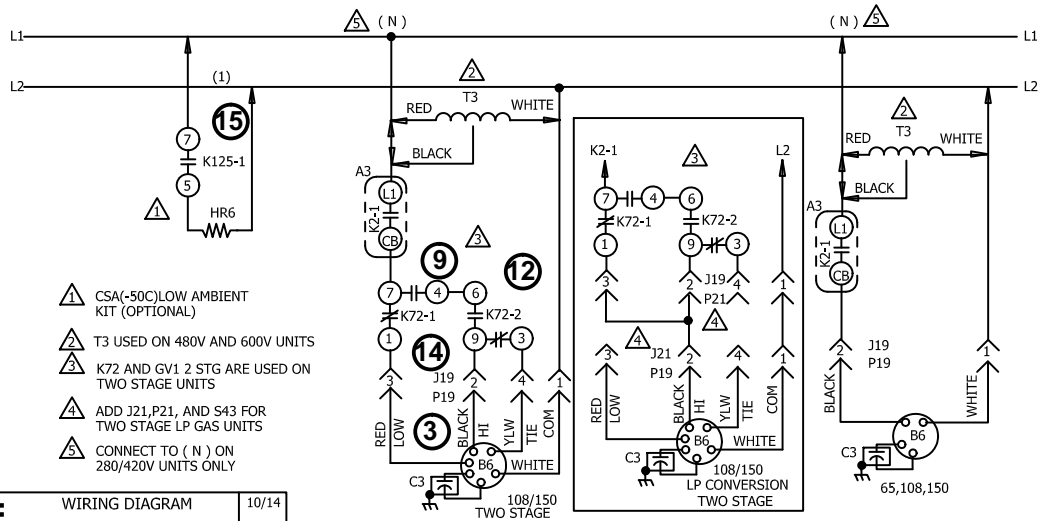

10/14		WIRING DIAGRAM 537776-01	10/14
HEATING			
GAS HEAT - KGA, KGB - 65 THRU 150 UNITS			
SECTION A		REV. 0	
Supersedes 537061-02		New Form No. 537776-01	

First Stage Heat:

1. The thermostat initiates W1 heating demand.
2. 24VAC is routed from TB1 to ignition control A3. A3 proves N.C. primary limit S10 and N.C. rollout switch S47.
3. Combustion air inducer blower B6 is energized.
4. After the combustion air inducer B6 has reached full speed, the combustion air proving switch S18 contacts close.
5. After a 30 second delay A3 energizes the ignitor and gas valve GV1 on first stage.

Second Stage Heat:

6. With first stage heat operating, an additional heating demand from the thermostat initiates W2.
7. A second stage heating demand is received by ignition control A3.
8. A3 energizes gas valve GV1 on second stage.
9. Relay K72-1 terminals 1 and 7 open, 7 and 4 close. K72-2 terminals 6 and 9 close and 9 and 3 open, energizing combustion air inducer B6 on high speed.

End of Second Stage Heat:

10. Heating demand is satisfied. Terminal W2 (second stage) is de-energized.
11. Second stage heat is de-energized on GV1 by ignition control A3.
12. K72 terminals 4 and 7 open and 1 and 7 close. K72 terminals 6 and 9 open, 9 and 3 close. Combustion air inducer B6 is now on low speed.

End of First Stage Heat:

13. Heating demand is satisfied. Terminal W1 (first stage) is de-energized.
14. Ignition A3 is de-energized in turn de-energizing gas valve GV1 and combustion air inducer B6.

Optional Low Ambient Kit:

(C.S.A. -50° C Low Ambient Kit)

15. Line voltage is routed through the N.C. low ambient kit thermostats S60 and S61, to energize low ambient kit heater HR6.

ELECTRONIC OR ELECTROMECHANICAL THERMOSTAT

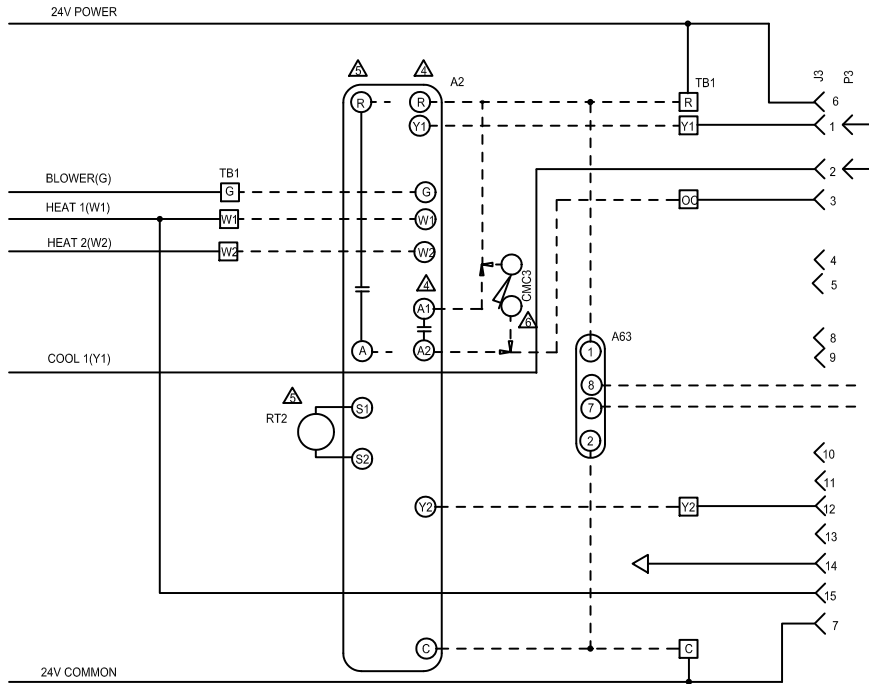

KEY	COMPONENT
A2	SENSOR-ELECTRONIC
A63	SENSOR-CO2
CMC3	CLOCK-TIME
J3	JACK-UNIT ECONOMIZER
P3	PLUG-LESS ECONOMIZER
RT2	SENSOR-REMOTE THERMOSTAT
TB1	TERMINAL STRIP-CLASS II VOLTAGE

- △ THERMOSTAT SUPPLIED BY USER
- △ REMOVE P3 WHEN ECONOMIZER IS USED
- △ J3 MAXIMUM LOAD 20VA 24VAC CLASS II
- △ T7300 THERMOSTAT
- △ T88220 TOUCHSCREEN THERMOSTAT
- △ TIME CLOCK CONTACTS (OPT) CLOSED OCCUPIED

DESIGNATES OPTIONAL WIRING
 CLASS II FIELD WIRING

06/13	WIRING DIAGRAM	06/13
537637-01		
ACCESSORIES		
ELECTRONIC OR ELECTROMECHANICAL THERMOSTAT FOR K SERIES		
SECTION C		REV 0
Supersedes 537483-01	New Form No. 537637-01	

POWER:

- Terminal strip TB1 found in the main control box supplies thermostat components with 24VAC.

OPERATION:

- TB1 receives data from the electronic thermostat A2 (Y1, Y2, W1, W2, G) and energizes the appropriate components for heat or cool demand.

ECONOMIZER

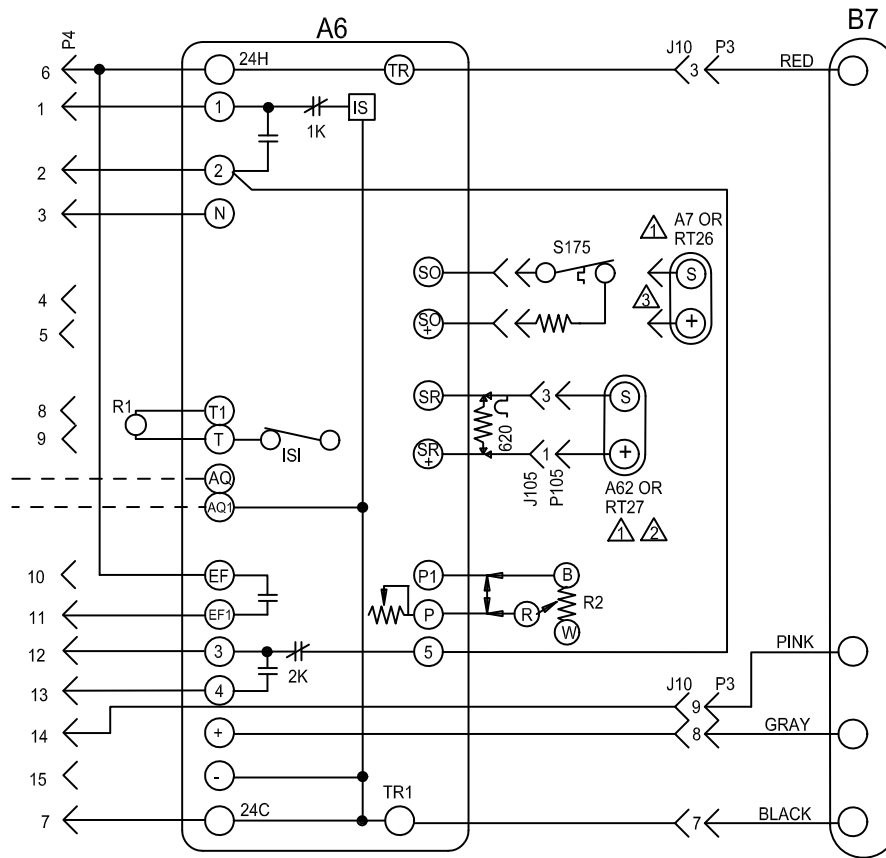

KEY	COMPONENT
A6	CONTROL-SOLID STATE ENTHALPY
A7	SENSOR-SOLID STATE ENTHALPY
A62	SENSOR-ENTHALPY, INDOOR
B7	MOTOR-DAMPER, ECONOMIZER
J10	JACK, ECONOMIZER
P3	PLUG, ECONOMIZER
P4	PLUG-ECONOMIZER
R1	SENSOR-MIXED AIR OR SUPPLY AIR
R2	POT-MINIMUM POSITION
RT26	SENSOR-OUTDOOR AIR TEMP
RT27	SENSOR-INDOOR AIR TEMP
S175	THERMOSTAT, SENSIBLE AIR

- ⚠ RT26 AND RT27, TEMPERATURE SENSORS MAY BE USED INSTEAD OF A7 AND A62 ENTHALPY SENSORS
- ⚠ A62 ENTHALPY SENSOR OR RT27 USED FOR DIFFERENTIAL SENSING
- ⚠ OPTIONAL OUTDOOR AIR THERMOSTAT TO REPLACE RT26 SENSIBLE SENSOR

DESIGNATES OPTIONAL WIRING
 CLASS II FIELD WIRING

08/15	 537620-01	08/15
ACCESSORIES		
ECONOMIZER LANDMARK A-BOX		
SECTION D1		REV 1
Supersedes Form No. 537484-01	New Form No. 537620-01	

SEQUENCE OF OPERATION

POWER:

1. Terminal strip TB1 found in the main control panel energizes the economizer components with 24VAC.

OPERATION:

2. Enthalpy sensor A7 and A62 (if differential enthalpy is used) communicates to the economizer control module A6 when to power the damper motor B7.
3. Economizer control module A6 supplies B7 with 0 - 10 VDC to control the positioning of economizer.
4. The damper actuator provides 2 to 10 VDC position feedback.

OUTDOOR AIR DAMPER

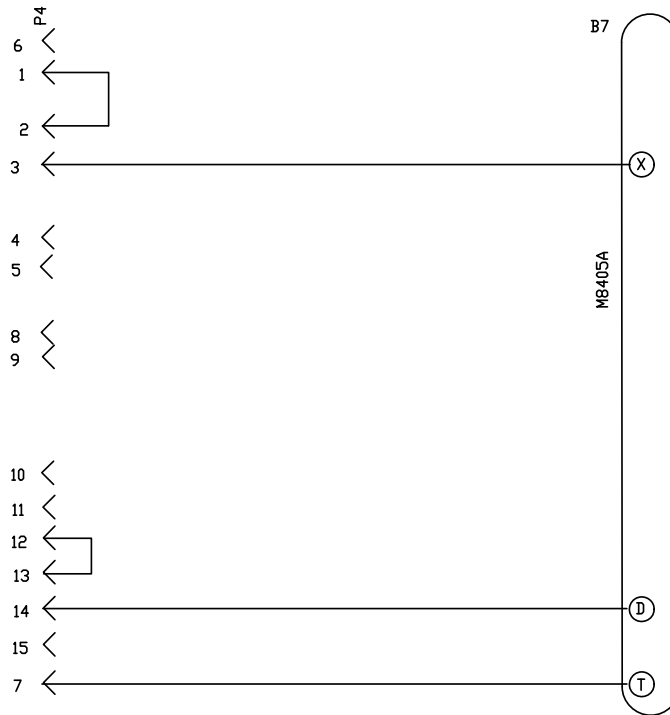

KEY	DESCRIPTION
B7	MOTOR-DAMPER, ECONOMIZER
P4	PLUG-ECONOMIZER

DESIGNATES OPTIONAL WIRING
 CLASS II FIELD WIRING

	WIRING DIAGRAM	11/07
ACCESSORIES		
MOTORIZED OAD FOR KCA/KGA,TCA/TGA UNITS		
ECONOMIZER SECTION D2		
Supersedes Form No.	New Form No. 534,489W	

© 2007

Litho U.S.A.

SEQUENCE OF OPERATION

OPERATION:

Occupied Mode

1. 24 volt signal from terminal "OC" on TB1 opens B7 dampers to minimum position.

Unoccupied Mode

2. Dampers remain closed.