

Service Literature

LGH156H through 300U

The LGH156H, 180H, 180U, 210H, 240H, 240U, 300S and 300U. (LGH156H/300S) units are configured to order units (CTO) with a wide selection of factory installed options.

LGH156H is available in 260,000 Btuh or 360,000 Btuh (76.2 or 105.5 kW) and has the option for single stage heat in 169,000 Btuh (49.5 kW).

LGH180H, 180U, 210H, 240H, 240U, 300S and 300U units are available in 260,000, 360,000 or 480,00 Btuh (76.2, 105.5 or 140.7 kW) heating inputs.

The LGH180H/U and 210H also has an optional single stage heat in 169,000 Btuh (49.5 kW).

Gas heat sections are designed with aluminized steel tube heat exchangers with stainless steel as an option.

Cooling capacities range from 13 to 25 tons (45.7 to 88 kW). LGH156H, 180H, and 210H utilize three compressors while LGH180U, 240H, 240U, 300S and 300U utilize four compressors.

Units are designed for R410A refrigerant. See unit nameplate. Operating pressures and pressure switch settings are significantly higher than R22 charged units. Service equipment must be rated for R410A.

Multi-Stage Air Volume MSAV[®] blower option is available. The VFD-driven blower will operate at lower speeds when demand is low and increase to higher speeds when demand is high.

Variable speed VAV system is available as an option which enables supply duct static measurement to control blower CFM and discharge air temperature to control cooling stages.

All LGH units are designed to accept any of several different energy management thermostat control systems with minimum field wiring. Factory- or field-provided control options connect to the unit through Smartwire[™] connectors. When "plugged in" the controls become an integral part of the unit wiring.

Information contained in this manual is intended for use by qualified service technicians only. All specifications are subject to change. Procedures outlined in this manual are presented as a recommendation only and do not supersede or replace local or state codes.

If the unit must be lifted for service, rig unit by attaching four cables to the holes located in the unit base rail (two holes at each corner). Refer to the installation instructions for the proper rigging technique.

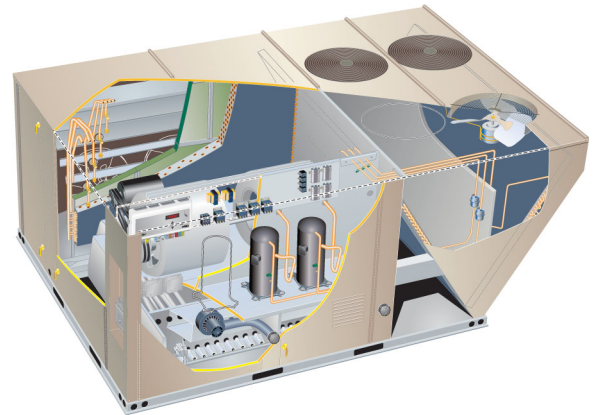

⚠ WARNING

Improper installation, adjustment, alteration, service or maintenance can cause property damage, personal injury or loss of life. Installation and service must be performed by a qualified installer or service agency.

⚠ WARNING



Electric shock hazard. Can cause injury or death. Before attempting to perform any service or maintenance, turn the electrical power to unit OFF at disconnect switch(es). Unit may have multiple power supplies.

Table of Contents

Options / Accessories	Page 2
Specifications	Page 9
Blower Data	Page 15
Electrical Data	Page 18
Unit Parts Arrangement	Page 23
I-Unit Components	Page 23
Control Box Parts Arrangement	Page 24
II-Placement and Installation	Page 46
III-Charging	Page 46
IV-Start Up - Operation	Page 79
V-System Service Checks	Page 83
High Altitude	Page 85
VI-Maintenance	Page 86
VII-Accessories	Page 87
VIII-Hot Gas Re-Heat	Page 91
IX-Staged Blower	Page 95
XI-Wiring and Operation Sequence	Page 102

OPTIONS / ACCESSORIES

Item Description	Model Number	Catalog Number	Unit Model No				
			156	180	210	240	300
COOLING SYSTEM							
Condensate Drain Trap	PVC - C1TRAP20AD2	76W26	OX	OX	OX	OX	OX
	Copper - C1TRAP10AD2	76W27	OX	OX	OX	OX	OX
Conventional Fin/Tube Condenser Coil (replaces Environ™ Coil System)		Factory	O	O	O	O	O
Corrosion Protection		Factory	O	O	O	O	O
Drain Pan Overflow Switch	E1SNSR71AD1	68W88	OX	OX	OX	OX	OX
Efficiency	High		O	O	O	O	
	Standard						O
Refrigerant Type		R-410A	O	O	O	O	O
Service valves (not for Environ™ Coil System or Humiditrol® Dehumidification)		Factory	O	O	O	O	O
HEATING SYSTEM							
Bottom Gas Piping Kit	C1GPKT01C-1	85M31	OX	OX	OX	OX	OX
Combustion Air Intake Extensions (order two)	LTACA1K10/15	89L97	X	X	X	X	X
Gas Heat Input	Low - 169,000 Btuh	Factory	O	O	O		
	Standard - 260,000 Btuh	Factory	O	O	O	O	O
	Medium - 360,000 Btuh	Factory	O	O	O	O	O
	High - 480,000 Btuh	Factory		O	O	O	O
Low Temperature Vestibule Heater	208/230V-3ph - C1LTVH10C-2Y	13X66	OX	OX	OX	OX	OX
	460V-3ph - C1LTVH10C-2G	13X67	OX	OX	OX	OX	OX
	575V-3ph - C1LTVH10C-2J	13X68	OX	OX	OX	OX	OX
LPG/Propane Conversion Kits (Order 2 kits)	Low Heat - C1PROP25C11	14N28	X	X	X		
	Standard Heat - C1PROP25C11	14N28	X	X	X	X	X
	Medium Heat - C1PROP26C11	14N29	X	X	X	X	X
	High Heat - C1PROP27C11	14N30		X	X	X	X
Stainless Steel Heat Exchanger		Factory	O	O	O	O	O
Vertical Vent Extension Kit (Order two kits)	C1EXTN2021	42W16	X	X	X	X	X
BLOWER - SUPPLY AIR							
Blower Option	CAV (Constant Air Volume)	Factory	O	O	O	O	O
	VAV (Variable Air Volume) supply air blower option (Without VFD Bypass Control)	Factory	O	O		O	
MSAV® (Multi-Stage Air Volume) supply air blower option (With VFD Bypass Control)		Factory	O	O	O	O	O
		Factory	O	O	O	O	O
Motors - CAV (Constant Air Volume)	Belt Drive (standard efficiency) - 2 hp	Factory	O				
	Belt Drive (standard or high efficiency) - 3 hp	Factory	O	O	O		
	Belt Drive (standard efficiency) - 5 hp	Factory	O	O	O	O	O
	Belt Drive (standard efficiency) - 7.5 hp	Factory		O	O	O	O
	Belt Drive (standard efficiency) - 10 hp	Factory				O	O
Motors - VAV (Variable Air Volume)	Belt Drive (standard or high efficiency) - 2 hp	Factory	O				
	Belt Drive (standard or high efficiency) - 3 hp	Factory	O	O			
	Belt Drive (standard efficiency) - 5 hp	Factory	O	O		O	
	Belt Drive (standard efficiency) - 7.5 hp	Factory		O		O	
	Belt Drive (standard efficiency) - 10 hp	Factory				O	
Motors - MSAV® (Multi-Stage Air Volume)	Belt Drive (standard efficiency) - 2 hp	Factory	O				
	Belt Drive (standard efficiency) - 3 hp	Factory	O	O	O		
	Belt Drive (standard efficiency) - 5 hp	Factory	O	O	O	O	O
	Belt Drive (standard efficiency) - 7.5 hp	Factory		O	O	O	O
	Belt Drive (standard efficiency) - 10 hp	Factory				O	O
Drive Kits See Blower Data Tables for usage and selection	Kit #1 535-725 rpm	Factory	O	O	O		
	Kit #2 710-965 rpm	Factory	O	O	O		
	Kit #3 685-856 rpm	Factory	O	O	O	O	O
	Kit #4 850-1045 rpm	Factory	O	O	O	O	O
	Kit #5 945-1185 rpm	Factory	O	O	O	O	O
	Kit #6 850-1045 rpm	Factory		O	O	O	O
	Kit #7 945-1185 rpm	Factory		O	O	O	O
	Kit #8 1045-1285 rpm	Factory		O	O	O	O
	Kit #10 1045-1285 rpm	Factory				O	O
	Kit #11 1135-1365 rpm	Factory				O	O
	Blower Belt Auto-Tensioner	Factory	O	O	O	O	O

NOTE - Catalog and model numbers shown are for ordering field installed accessories.

OX - Configure To Order (Factory Installed) or Field Installed

O = Configure To Order (Factory Installed)

X = Field Installed

OPTIONS / ACCESSORIES

Item Description	Model Number	Catalog Number	Unit Model No				
			156	180	210	240	300
CONTROLS							
Blower Proving Switch	C1SNSR35FF1	53W65	OX	OX	OX	OX	OX
Commercial Controls	Prodigy® Control System - BACnet® Module - C0CTRL60AE1L	59W51	OX	OX	OX	OX	OX
	Prodigy® Control System - LonTalk® Module - C0CTRL65FF1	54W27	OX	OX	OX	OX	OX
	Novar® LSE	Factory	O	O	O	O	O
L Connection® Building Automation System		---	X	X	X	X	X
Dirty Filter Switch	E1SNSR55C-1	53W68	OX	OX	OX	OX	OX
Fresh Air Tempering	C1SNSR75AD1	58W63	OX	OX	OX	OX	OX
General Purpose Control Kit	E1GPBK30C1	13J78	X	X	X	X	X
Smoke Detector - Supply or Return (Power board and one sensor)	C1SNSR44C-1	83W40	OX	OX	OX	OX	OX
Smoke Detector - Supply and Return (Power board and two sensors)	C1SNSR43C-1	83W41	OX	OX	OX	OX	OX
INDOOR AIR QUALITY							
Air Filters							
Healthy Climate® High Efficiency Air Filters 24 x 24 x 2 (Order 6 per unit)	MERV 8 - C1FLTR15C-1-	54W67	OX	OX	OX	OX	OX
	MERV 13 - C1FLTR40C-1-	52W40	OX	OX	OX	OX	OX
Replacement Media Filter With Metal Mesh Frame (includes non-pleated filter media)	C1FLTR30C-1-	44N61	OX	OX	OX	OX	OX
Indoor Air Quality (CO₂) Sensors							
Sensor - Wall-mount, off-white plastic cover with LCD display	C0SNSR50AE1L	77N39	X	X	X	X	X
Sensor - Wall-mount, off-white plastic cover, no display	C0SNSR52AE1L	87N53	X	X	X	X	X
Sensor - Black plastic case with LCD display, rated for plenum mounting	C0SNSR51AE1L	87N52	X	X	X	X	X
Sensor - Wall-mount, black plastic case, no display, rated for plenum mounting	C0MISC19AE1	87N54	X	X	X	X	X
CO ₂ Sensor Duct Mounting Kit - for downflow applications	C0MISC19AE1-	85L43	X	X	X	X	X
Aspiration Box - for duct mounting non-plenum rated CO ₂ sensors (87N53 or 77N39)	C0MISC16AE1-	90N43	X	X	X	X	X
UVC Germicidal Light Kit							
¹ Healthy Climate® UVC Light Kit (110/230v-1ph)		54W65	X	X	X	X	X
ELECTRICAL							
Voltage 60 hz	208/230V - 3 phase	Factory	O	O	O	O	O
	460V - 3 phase	Factory	O	O	O	O	O
	575V - 3 phase	Factory	O	O	O	O	O
HACR Circuit Breakers		Factory	O	O	O	O	O
Short-Circuit Current Rating (SCCR) of 100kA (includes Phase/Voltage Detection)		Factory	O	O	O	O	O
Disconnect Switch (see Disconnect Table for usage, page 51)	80 amp - E1DISC080C-1	54W88	OX	OX	OX	OX	OX
	150 amp - E1DISC150C-1	54W89	OX	OX	OX	OX	OX
	250 amp - C1DISC250A-D1	90W82					OX
GFI Service Outlets	15 amp non-powered, field-wired (208/230V, 460V, 575V) LTAGFIK10/15	74M70	OX	OX	OX	OX	OX
	15 amp factory-wired and powered (208/230V, 460V, 575V)	Factory	O	O	O	O	O
	20 amp non-powered, field-wired (575V only) C1GFCI20FF1	67E01	OX	OX	OX	OX	OX
Weatherproof Cover for GFI	C1GFCI99FF1	10C89	X	X	X	X	X
Phase/Voltage Detection (Optional for CAV options only, furnished with MSAV® option)		Factory	O	O	O	O	O

¹ Lamps operate on 110-230V single-phase power supply. Step-down transformer must be field supplied for field installation in 460V and 575V rooftop units (transformer is furnished for factory installed light kits). Alternately, a separate 110V power supply may be used to directly power the UVC ballast(s).

NOTE - Catalog and model numbers shown are for ordering field installed accessories.

OX - Configure To Order (Factory Installed) or Field Installed

O = Configure To Order (Factory Installed)

X = Field Installed

OPTIONS / ACCESSORIES

Item Description	Model Number	Catalog Number	Unit Model No				
			156	180	210	240	300
ECONOMIZER							
High Performance Economizer (Approved for California Title 24 Building Standards AMCA Class 1A Certified)							
High Performance Economizer Downflow or Horizontal Applications - Includes Outdoor Air Hood. Order Downflow or Horizontal Barometric Relief Dampers separately.	E1ECON17C-2	16Y98	OX	OX	OX	OX	OX
Economizer Controls							
Differential Enthalpy (Not for Title 24)	Order 2 - C1SNSR64FF1	53W64	OX	OX	OX	OX	OX
Sensible Control	Sensor is Furnished	Factory	O	O	O	O	O
Single Enthalpy (Not for Title 24)	C1SNSR64FF1	53W64	OX	OX	OX	OX	OX
Global Control	Sensor Field Provided	Factory	O	O	O	O	O
Building Pressure Control	E1GPBK20C1	13J77	X	X	X	X	X
Outdoor Air CFM Control	E1GPBK10C1	13J76	X	X	X	X	X
Barometric Relief Dampers With Exhaust Hood							
Downflow Barometric Relief Dampers	C1DAMP50C	54W78	OX	OX	OX	OX	OX
Horizontal Barometric Relief Dampers	LAGEDH18/24	16K99	X	X	X	X	X
OUTDOOR AIR							
Outdoor Air Dampers With Outdoor Air Hood							
Motorized	C1DAMP20C-1	13U04	OX	OX	OX	OX	OX
Manual	C1DAMP10C-2	13U05	OX	OX	OX	OX	OX
POWER EXHAUST							
Standard Static	208/230V - C1PWRE11C-1Y	75W90	OX	OX	OX	OX	OX
	460V - C1PWRE11C-1G	75W91	OX	OX	OX	OX	OX
	575V - C1PWRE11C-1J	75W92	OX	OX	OX	OX	OX
SCCR Rated, Standard Static	208/230V - C1PWRE11C-1Y	75W90	OX	OX	OX	OX	OX
	460V - C1PWRE11C-2G	17J93	OX	OX	OX	OX	OX
	575V - C1PWRE11C-2J	17J98	OX	OX	OX	OX	OX
HUMIDITROL® CONDENSER REHEAT OPTION (CAV AND MSAV®) MODELS ONLY							
Humiditrol Dehumidification Option		Factory	O	O	O	O	O
Humidity Sensor Kit, Remote mounted (required)	C0SNSR31AE-1	17M50	X	X	X	X	X
CABINET							
Combination Coil/Hail Guards	Environ™ Coil System - C1GARD52C12	15T92	X				
	Environ™ Coil System - C1GARD52C22	15T93		X	X	X	X
	Conventional Fin/Tube Condenser Coil - C1GARD51C11	13T08	X				
	Conventional Fin/Tube Condenser Coil - C1GARD51C21	13T12		X	X	X	X

NOTE - Catalog and model numbers shown are for ordering field installed accessories.

OX - Configure To Order (Factory Installed) or Field Installed

O = Configure To Order (Factory Installed)

X = Field Installed

OPTIONS / ACCESSORIES

Item Description	Model Number	Catalog Number	Unit Model No				
			156	180	210	240	300
ROOF CURBS							
Hybrid Roof Curbs, Downflow							
8 in. height	C1CURB70C-1	11F58	X	X	X	X	X
14 in. height	C1CURB71C-1	11F59	X	X	X	X	X
18 in. height	C1CURB72C-1	11F60	X	X	X	X	X
24 in. height	C1CURB73C-1	11F61	X	X	X	X	X
Adjustable Pitch Curb							
14 in. height	L1CURB55C	43W26	X	X	X	X	X
Standard Roof Curbs, Horizontal - Requires Horizontal Return Air Panel Kit							
26 in. height - slab applications	C1CURB14C-1	11T89	X	X	X	X	
30 in. height - slab applications	C1CURB15C-1	11T90					X
37 in. height - rooftop applications	C1CURB16C-1	11T96	X	X	X	X	
41 in. height - rooftop applications	C1CURB17C-1	11T97					X
Insulation Kit For Standard Horizontal Roof Curbs							
for C1CURB14C-1 (26 in.)	C1INSU11C-1	73K32	X	X	X	X	
for C1CURB15C-1 (30 in.)	C1INSU12C-1	73K33					X
for C1CURB16C-1 (37 in.)	C1INSU13C-1	73K34	X	X	X	X	
for C1CURB17C-1 (41 in.)	C1INSU14C-1	73K35					X
Horizontal Return Air Panel Kit							
Required for Horizontal Applications with Roof Curb	C1HRAP10C-1	87M00	X	X	X	X	X
CEILING DIFFUSERS							
Step-Down - Order one	RTD11-185S	13K63	X	X			
	RTD11-275S	13K64			X	X	X
Flush - Order one	FD11-185S	13K58	X	X			
	FD11-275S	13K59			X	X	X
Transitions (Supply and Return) - Order one	C1DIFF33C-1	12X68	X	X			
	C1DIFF34C-1	12X70			X	X	X

NOTE - Catalog and model numbers shown are for ordering field installed accessories.

OX - Configure To Order (Factory Installed) or Field Installed

O = Configure To Order (Factory Installed)

X = Field Installed

OPTIONS / ACCESSORIES

Item Description	Model Number	Catalog Number	Unit Model No.		
			180U	240U	300U
COOLING SYSTEM					
Condensate Drain Trap	PVC - C1TRAP20AD2	76W26	OX	OX	OX
	Copper - C1TRAP10AD2	76W27	OX	OX	OX
Corrosion Protection		Factory	O	O	O
Drain Pan Overflow Switch	E1SNSR71AD1	68W88	OX	OX	OX
Refrigerant Type		R-410A	O	O	O
HEATING SYSTEM					
Bottom Gas Piping Kit	C1GPKT01C-1	85M31	OX	OX	OX
Combustion Air Intake Extensions (order two)	LTACA1K10/15	89L97	X	X	X
Gas Heat Input	Low - 169,000 Btuh	Factory	O		
	Standard - 260,000 Btuh	Factory	O	O	O
	Medium - 360,000 Btuh	Factory	O	O	O
	High - 480,000 Btuh	Factory	O	O	O
Low Temperature Vestibule Heater	208/230V-3ph - C1LTVH10C-2Y	13X66	OX	OX	OX
	460V-3ph - C1LTVH10C-2G	13X67	OX	OX	OX
	575V-3ph - C1LTVH10C-2J	13X68	OX	OX	OX
LPG/Propane Conversion Kits (Order 2 kits)	Low Heat - C1PROP25C11	14N28	X		
	Standard Heat - C1PROP25C11	14N28	X	X	X
	Medium Heat - C1PROP26C11	14N29	X	X	X
	High Heat - C1PROP27C11	14N30	X	X	X
Stainless Steel Heat Exchanger		Factory	O	O	O
Vertical Vent Extension Kit (Order two kits)	C1EXTN2021	42W16	X	X	X
BLOWER - SUPPLY AIR					
Blower	MSAV (multi-stage air volume) blower option (With VFD Bypass Control)	Factory	O	O	O
	MSAV (multi-stage air volume) blower option (Without VFD Bypass Control)	Factory	O	O	O
Motors - MSAV (multi-stage air volume)	Belt Drive (standard efficiency) - 3 hp	Factory	O		
	Belt Drive (standard efficiency) - 5 hp	Factory	O	O	O
	Belt Drive (standard efficiency) - 7.5 hp	Factory	O	O	O
	Belt Drive (standard efficiency) - 10 hp	Factory		O	O
Drive Kits See Blower Data Tables for usage and selection	Kit #1 535-725 rpm	Factory	O		
	Kit #2 710-965 rpm	Factory	O		
	Kit #3 685-856 rpm	Factory	O	O	O
	Kit #4 850-1045 rpm	Factory	O	O	O
	Kit #5 945-1185 rpm	Factory	O	O	O
	Kit #6 850-1045 rpm	Factory	O	O	O
	Kit #7 945-1185 rpm	Factory	O	O	O
	Kit #8 1045-1285 rpm	Factory	O	O	O
	Kit #10 1045-1285 rpm	Factory		O	O
	Kit #11 1135-1365 rpm	Factory		O	O
	Blower Belt Auto-Tensioner	Factory	O	O	O
CONTROLS					
Blower Proving Switch	C1SNSR35FF1	53W65	OX	OX	OX
Commercial Controls	Prodigy® Control System - BACnet® Module - C0CTRL60AE1L	59W51	OX	OX	OX
	Prodigy® Control System - LonTalk® Module - C0CTRL65FF1	54W27	OX	OX	OX
	Novar® LSE	Factory	O	O	O
	L Connection® Building Automation System	- - -	X	X	X
Dirty Filter Switch	E1SNSR55C-1	53W68	OX	OX	OX
Fresh Air Tempering	C1SNSR75AD1	58W63	OX	OX	OX
General Purpose Control Kit	E1GPBK30C1	13J78	X	X	X
Smoke Detector - Supply or Return (Power board and one sensor)	C1SNSR44C-1	83W40	OX	OX	OX
Smoke Detector - Supply and Return (Power board and two sensors)	C1SNSR43C-1	83W41	OX	OX	OX

NOTE - Catalog and model numbers shown are for ordering field installed accessories.

OX - Configure To Order (Factory Installed) or Field Installed

O = Configure To Order (Factory Installed)

X = Field Installed

OPTIONS / ACCESSORIES

Item Description	Model Number	Catalog Number	Unit Model No.			
			180U	240U	300U	
INDOOR AIR QUALITY						
Air Filters						
Healthy Climate® High Efficiency Air Filters 24 x 24 x 2 (Order 6 per unit)	MERV 8 - C1FLTR15C-1-	54W67	OX	OX	OX	
	MERV 13 - C1FLTR40C-1-	52W40	OX	OX	OX	
Replacement Media Filter With Metal Mesh Frame (includes non-pleated filter media)	C1FLTR30C-1-	44N61	OX	OX	OX	
Indoor Air Quality (CO₂) Sensors						
Sensor - Wall-mount, off-white plastic cover with LCD display	C0SNSR50AE1L	77N39	X	X	X	
Sensor - Wall-mount, off-white plastic cover, no display	C0SNSR52AE1L	87N53	X	X	X	
Sensor - Black plastic case with LCD display, rated for plenum mounting	C0SNSR51AE1L	87N52	X	X	X	
Sensor - Wall-mount, black plastic case, no display, rated for plenum mounting	C0MISC19AE1	87N54	X	X	X	
CO ₂ Sensor Duct Mounting Kit - for downflow applications	C0MISC19AE1-	85L43	X	X	X	
Aspiration Box - for duct mounting non-plenum rated CO ₂ sensors (87N53 or 77N39)	C0MISC16AE1-	90N43	X	X	X	
UVC Germicidal Light Kit						
¹ Healthy Climate® UVC Light Kit (110/230v-1ph)		54W65	X	X	X	
ELECTRICAL						
Voltage 60 hz	208/230V - 3 phase	Factory	O	O	O	
	460V - 3 phase	Factory	O	O	O	
	575V - 3 phase	Factory	O	O	O	
HACR Circuit Breakers		Factory	O	O	O	
Short-Circuit Current Rating (SCCR) of 100kA		Factory	O	O	O	
Disconnect Switch (see Disconnect Table for usage, page 30)	80 amp - E1DISC080C-1	54W88	OX	OX	OX	
	150 amp - E1DISC150C-1	54W89	OX	OX	OX	
GFI Service Outlets	15 amp non-powered, field-wired (208/230V, 460V, 575V)	LTAGFIK10/15	74M70	OX	OX	OX
	15 amp factory-wired and powered (208/230V, 460V, 575V)	Factory		O	O	O
	20 amp non-powered, field-wired (575V only)	C1GFCI20FF1	67E01	OX	OX	OX
Weatherproof Cover for GFI	C1GFCI99FF1	10C89	X	X	X	
ECONOMIZER						
High Performance Economizer (Approved for California Title 24 Building Standards / AMCA Class 1A Certified)						
High Performance Economizer Downflow or Horizontal Applications - Includes Outdoor Air Hood. Order Downflow or Horizontal Barometric Relief Dampers separately.	E1ECON17C-2	16Y98	OX	OX	OX	
Economizer Controls						
Differential Enthalpy (Not for Title 24)	Order 2 - C1SNSR64FF1	53W64	OX	OX	OX	
Sensible Control	Sensor is Furnished	Factory	O	O	O	
Single Enthalpy (Not for Title 24)	C1SNSR64FF1	53W64	OX	OX	OX	
Global Control	Sensor Field Provided	Factory	O	O	O	
Building Pressure Control	E1GPBK20C1	13J77	X	X	X	
Outdoor Air CFM Control	E1GPBK10C1	13J76	X	X	X	
Barometric Relief Dampers With Exhaust Hood						
Downflow Barometric Relief Dampers	C1DAMP50C	54W78	OX	OX	OX	
Horizontal Barometric Relief Dampers	LAGEDH18/24	16K99	X	X	X	

¹ Lamps operate on 110-230V single-phase power supply. Step-down transformer must be field supplied for field installation in 460V and 575V rooftop units (transformer is furnished for factory installed light kits). Alternately, a separate 110V power supply may be used to directly power the UVC ballast(s).

NOTE - Catalog and model numbers shown are for ordering field installed accessories.

OX - Configure To Order (Factory Installed) or Field Installed

O = Configure To Order (Factory Installed)

X = Field Installed

OPTIONS / ACCESSORIES

Item Description	Model Number	Catalog Number	Unit Model No.		
			180U	240U	300U
OUTDOOR AIR					
Outdoor Air Dampers With Outdoor Air Hood					
Motorized	C1DAMP20C-1	13U04	OX	OX	OX
Manual	C1DAMP10C-2	13U05	OX	OX	OX
POWER EXHAUST					
Standard Static	208/230V - C1PWRE11C-1Y	75W90	OX	OX	OX
	460V - C1PWRE11C-1G	75W91	OX	OX	OX
	575V - C1PWRE11C-1J	75W92	OX	OX	OX
SCCR Rated, Standard Static	208/230V - C1PWRE11C-1Y	75W90	OX	OX	OX
	460V - C1PWRE11C-2G	17J93	OX	OX	OX
	575V - C1PWRE11C-2J	17J98	OX	OX	OX
CABINET					
Combination Coil/Hail Guards	C1GARD51C21	13T12	X	X	X
ROOF CURBS					
Hybrid Roof Curbs, Downflow					
8 in. height	C1CURB70C-1	11F58	X	X	X
14 in. height	C1CURB71C-1	11F59	X	X	X
18 in. height	C1CURB72C-1	11F60	X	X	X
24 in. height	C1CURB73C-1	11F61	X	X	X
Adjustable Pitch Curb					
14 in. height	L1CURB55C	43W26	X	X	X
Standard Roof Curbs, Horizontal - Requires Horizontal Return Air Panel Kit					
26 in. height - slab applications	C1CURB14C-1	11T89	X	X	X
37 in. height - rooftop applications	C1CURB16C-1	11T96	X	X	X
Insulation Kit For Standard Horizontal Roof Curbs					
for C1CURB14C-1	C1INSU11C-1-	73K32	X	X	X
for C1CURB16C-1	C1INSU13C-1-	73K34	X	X	X
Horizontal Return Air Panel Kit					
Required for Horizontal Applications with Roof Curb	C1HRAP10C-1-	87M00	X	X	X
CEILING DIFFUSERS					
Step-Down - Order one	RTD11-185S	13K63	X		
	RTD11-275S	13K64		X	X
Flush - Order one	FD11-185S	13K58	X		
	FD11-275S	13K59		X	X
Transitions (Supply and Return) - Order one	C1DIFF33C-1	12X68	X		
	C1DIFF34C-1	12X70		X	X

NOTE - Catalog and model numbers shown are for ordering field installed accessories.

OX - Configure To Order (Factory Installed) or Field Installed

O = Configure To Order (Factory Installed)

X = Field Installed

SPECIFICATIONS

General Data		Nominal Tonnage	13 Ton	13 Ton	13 Ton	
		Model Number	LGH156H4B	LGH156H4V	LGH156H4M	
		Efficiency Type	High	High	High	
		Blower Type	CAV (Constant Air Volume)	VAV (Variable Air Volume)	MSAV® (Multi-Stage Air Volume)	
Cooling Performance	Gross Cooling Capacity - Btuh		154,000	152,000	154,000	
	¹ Net Cooling Capacity - Btuh		150,000	148,000	150,000	
	AHRI Rated Air Flow - cfm		5000	4600	5000	
	Total Unit Power - kW		12.5	12.3	12.5	
	¹ EER (Btuh/Watt)		12.0	12.0	12.0	
	² IEER (Btuh/Watt)		13.2	14.5	14.1	
Refrigerant Charge	Refrigerant Type		R-410A	R-410A	R-410A	
	Environ™ Coil System	Circuit 1	5 lbs. 12 oz.	5 lbs. 0 oz.	5 lbs. 12 oz.	
		Circuit 2	5 lbs. 4 oz.	5 lbs. 8 oz.	5 lbs. 4 oz.	
		Circuit 3	5 lbs. 10 oz.	5 lbs. 0 oz.	5 lbs. 10 oz.	
	Environ™ Coil System with Humiditrol®	Circuit 1	5 lbs. 14 oz.	---	5 lbs. 14 oz.	
		Circuit 2	5 lbs. 8 oz.	---	5 lbs. 8 oz.	
		Circuit 3	5 lbs. 12 oz.	---	5 lbs. 12 oz.	
	Conventional Fin/Tube Coil Option	Circuit 1	10 lbs. 0 oz.	---	10 lbs. 0 oz.	
		Circuit 2	10 lbs. 0 oz.	---	10 lbs. 0 oz.	
		Circuit 3	9 lbs. 8 oz.	---	9 lbs. 8 oz.	
	Conventional Fin/Tube With Humiditrol®	Circuit 1	12 lbs. 0 oz.	---	12 lbs. 0 oz.	
		Circuit 2	12 lbs. 0 oz.	---	12 lbs. 0 oz.	
		Circuit 3	9 lbs. 8 oz.	---	9 lbs. 8 oz.	
	Gas Heating Options Available			Page 14		
	Compressor Type (number)			Scroll (3)	Scroll (3)	Scroll (3)
Outdoor Coils	Net face area (total) - sq. ft.		41.4	41.4	41.4	
	Environ™ (Fin/Tube)	Number of rows	1 (2)	1 (2)	1 (2)	
		Fins per inch	23 (20)	23 (20)	23 (20)	
Outdoor Coil Fans	Motor - (No.) horsepower		(3) 1/3	(3) 1/3	(3) 1/3	
	Motor rpm		1075	1075	1075	
	Total Motor watts		1100	1100	1100	
	Diameter - (No.) in.		(3) 24	(3) 24	(3) 24	
	Number of blades		3	3	3	
	Total Air volume - cfm		12,000	12,000	12,000	
Indoor Coils	Net face area (total) - sq. ft.		21.4	21.4	21.4	
	Tube diameter - in.		3/8	3/8	3/8	
	Number of rows		3	3	3	
	Fins per inch		14	14	14	
	Drain connection - No. and size		(1) 1 in. FPT	(1) 1 in. FPT	(1) 1 in. FPT	
	Expansion device type		Balance port TXV, removable head			
³ Indoor Blower and Drive Selection	Nominal motor output		2 hp, 3 hp, 5 hp			
	Max. usable motor output (US)		2.3 hp, 3.45 hp, 5.75 hp			
	Motor - Drive kit number		2 hp Kit 1 535-725 rpm Kit 2 710-965 rpm 3 hp Std. Eff. Kit 1 535-725 rpm Kit 2 710-965 rpm 3 hp High. Eff. Kit 3 685-856 rpm Kit 4 850-1045 rpm 5 hp Kit 3 - 685-856 rpm Kit 4 850-1045 rpm Kit 5 945-1185 rpm			
	Blower wheel nominal D x W - in.		(2) 15 x 15 in.	(2) 15 x 15 in.	(2) 15 x 15 in.	
	Filters	Type of filter		Fiberglass, disposable		
		Number and size - in.		(6) 24 x 24 x 2		
	Electrical characteristics			208/230V, 460V or 575V - 60 hertz - 3 phase		

NOTE - Net capacity includes evaporator blower motor heat deduction. Gross capacity does not include evaporator blower motor heat deduction.

¹ AHRI Certified to AHRI Standard 340/360; 95°F outdoor air temperature and 80°F db/67°F wb entering evaporator air; minimum external duct static pressure.

² Integrated Energy Efficiency Ratio tested according to AHRI Standard 340/360.

³ Using total air volume and system static pressure requirements determine from blower performance tables rpm and motor output required. Maximum usable output of motors furnished are shown. In Canada, nominal motor output is also maximum usable motor output. If motors of comparable output are used, be sure to keep within the service factor limitations outlined on the motor nameplate.

NOTE - Units equipped with MSAV® (Multi-Stage Air Volume) option are limited to a motor service factor of 1.0.

SPECIFICATIONS

General Data		Nominal Tonnage Model Number Efficiency Type Blower Type	15 Ton	15 Ton	15 Ton	17.5 Ton	17.5 Ton
			LGH180H4B	LGH180H4V	LGH180H4M	LGH210H4B	LGH210H4M
			High	High	High	High	High
			CAV (Constant Air Volume)	VAV (Variable Air Volume)	MSAV® (Multi-Stage Air Volume)	CAV (Constant Air Volume)	MSAV® (Multi-Stage Air Volume)
Cooling Performance	Gross Cooling Capacity - Btuh		176,000	176,000	176,000	204,000	204,000
	¹ Net Cooling Capacity - Btuh		172,000	172,000	172,000	198,000	198,000
	AHRI Rated Air Flow - cfm		5250	5250	5250	6125	6125
	Total Unit Power - kW		14.3	14.3	14.3	16.5	16.5
	¹ EER (Btuh/Watt)		12.0	12.0	12.0	12.0	12.0
	² IEER (Btuh/Watt)		13.5	15.2	13.7	13.0	14.0
Refrigerant Charge	Refrigerant Type		R-410A	R-410A	R-410A	R-410A	R-410A
	Environ™ Coil System	Circuit 1	6 lbs. 0 oz.	5 lbs. 4 oz.	6 lbs. 0 oz.	6 lbs. 12 oz.	6 lbs. 12 oz.
		Circuit 2	5 lbs. 10 oz.	5 lbs. 8 oz.	5 lbs. 10 oz.	6 lbs. 14 oz.	6 lbs. 14 oz.
		Circuit 3	5 lbs. 14 oz.	5 lbs. 8 oz.	5 lbs. 14 oz.	6 lbs. 14 oz.	6 lbs. 14 oz.
	Environ™ Coil System with Humiditrol®	Circuit 1	6 lbs. 8 oz.	---	6 lbs. 8 oz.	7 lbs. 4 oz.	7 lbs. 4 oz.
		Circuit 2	5 lbs. 12 oz.	---	5 lbs. 12 oz.	7 lbs. 0 oz.	7 lbs. 0 oz.
		Circuit 3	6 lbs. 9 oz.	---	6 lbs. 9 oz.	6 lbs. 4 oz.	6 lbs. 4 oz.
	Conventional Fin/Tube Coil Option	Circuit 1	12 lbs. 8 oz.	---	12 lbs. 8 oz.	13 lbs. 0 oz.	13 lbs. 0 oz.
		Circuit 2	12 lbs. 8 oz.	---	12 lbs. 8 oz.	13 lbs. 0 oz.	13 lbs. 0 oz.
		Circuit 3	12 lbs. 8 oz.	---	12 lbs. 8 oz.	13 lbs. 0 oz.	13 lbs. 0 oz.
	Conventional Fin/Tube With Humiditrol®	Circuit 1	14 lbs. 8 oz.	---	14 lbs. 8 oz.	15 lbs. 0 oz.	15 lbs. 0 oz.
		Circuit 2	14 lbs. 8 oz.	---	14 lbs. 8 oz.	15 lbs. 0 oz.	15 lbs. 0 oz.
		Circuit 3	12 lbs. 8 oz.	---	12 lbs. 8 oz.	13 lbs. 0 oz.	13 lbs. 0 oz.
	Gas Heating Options Available			Page 14			
	Compressor Type (number)			Scroll (3)	Scroll (3)	Scroll (3)	Scroll (3)
Outdoor Coils	Net face area (total) - sq. ft.		55.2	55.2	55.2	55.2	55.2
	Environ™ (Fin/Tube)	Number of rows	1 (2)	1 (2)	1 (2)	1 (2)	1 (2)
Fins per inch		23 (20)	23 (20)	23 (20)	23 (20)	23 (20)	
Outdoor Coil Fans	Motor - (No.) horsepower		(4) 1/3	(4) 1/3	(4) 1/3	(6) 1/3	(6) 1/3
	Motor rpm		1075	1075	1075	1075	1075
	Total Motor watts		1500	1500	1500	1950	1950
	Diameter - (No.) in.		(4) 24	(4) 24	(4) 24	(6) 24	(6) 24
	Number of blades		3	3	3	3	3
	Total Air volume - cfm		16,000	16,000	16,000	20,000	20,000
Indoor Coils	Net face area (total) - sq. ft.		21.4	21.4	21.4	21.4	21.4
	Tube diameter - in.		3/8	3/8	3/8	3/8	3/8
	Number of rows		3	3	3	4	4
	Fins per inch		14	14	14	14	14
	Drain connection - No. and size		(1) 1 in. FPT	(1) 1 in. FPT	(1) 1 in. FPT	(1) 1 in. FPT	(1) 1 in. FPT
		Expansion device type		Balance port TXV, removable head			
³ Indoor Blower and Drive Selection	Nominal motor output		3 hp, 5 hp, 7.5 hp				
	Max. usable motor output (US)		3.45 hp, 5.75 hp, 8.62 hp				
	Motor - Drive kit number		3 hp Std. Eff. Kit 1 535-725 rpm Kit 2 710-965 rpm 3 hp High. Eff. Kit 3 - 685-856 rpm Kit 4 850-1045 rpm 5 hp Kit 3 685-856 rpm Kit 4 850-1045 rpm Kit 5 945-1185 rpm 7.5 hp Kit 6 850-1045 rpm Kit 7 945-1185 rpm Kit 8 1045-1285 rpm				
	Blower wheel nominal D x W - in.		(2) 15 x 15				
	Filters	Type of filter		Fiberglass, disposable			
		Number and size - in.		(6) 24 x 24 x 2			
	Electrical characteristics			208/230V, 460V or 575V - 60 hertz - 3 phase			

NOTE - Net capacity includes evaporator blower motor heat deduction. Gross capacity does not include evaporator blower motor heat deduction.

¹ AHRI Certified to AHRI Standard 340/360; 95°F outdoor air temperature and 80°F db/67°F wb entering evaporator air; minimum external duct static pressure.

² Integrated Energy Efficiency Ratio tested according to AHRI Standard 340/360.

³ Using total air volume and system static pressure requirements determine from blower performance tables rpm and motor output required. Maximum usable output of motors furnished are shown. In Canada, nominal motor output is also maximum usable motor output. If motors of comparable output are used, be sure to keep within the service factor limitations outlined on the motor nameplate.

NOTE - Units equipped with MSAV® (Multi-Stage Air Volume) option are limited to a motor service factor of 1.0.

SPECIFICATIONS

General Data		Nominal Tonnage	20 Ton	20 Ton	20 Ton
		Model Number	LGH240H4B	LGH240H4V	LGH240H4M
		Efficiency Type	High	High	High
		Blower Type	CAV (Constant Air Volume)	VAV (Variable Air Volume)	MSAV® (Multi-Stage Air Volume)
Cooling Performance	Gross Cooling Capacity - Btuh		238,000	238,000	238,000
	¹ Net Cooling Capacity - Btuh		230,000	230,000	230,000
	AHRI Rated Air Flow - cfm		6400	6400	6400
	Total Unit Power - kW		19.2	19.2	19.2
	¹ EER (Btuh/Watt)		12.0	12.0	12.0
	² IEER (Btuh/Watt)		13.2	16.0	14.5
Refrigerant Charge	Refrigerant Type		R-410A	R-410A	R-410A
	Environ™ Coil System	Circuit 1	6 lbs. 4 oz.	6 lbs. 2 oz.	6 lbs. 4 oz.
		Circuit 2	6 lbs. 2 oz.	6 lbs. 6 oz.	6 lbs. 2 oz.
		Circuit 3	5 lbs. 14 oz.	6 lbs. 0 oz.	5 lbs. 14 oz.
		Circuit 4	5 lbs. 6 oz.	6 lbs. 10 oz.	5 lbs. 6 oz.
	Environ™ Coil System with Humiditrol®	Circuit 1	6 lbs. 4 oz.	---	6 lbs. 4 oz.
		Circuit 2	5 lbs. 10 oz.	---	5 lbs. 10 oz.
		Circuit 3	4 lbs. 14 oz.	---	4 lbs. 14 oz.
		Circuit 4	4 lbs. 14 oz.	---	4 lbs. 14 oz.
	Conventional Fin/Tube Coil Option	Circuit 1	10 lbs. 0 oz.	---	10 lbs. 0 oz.
		Circuit 2	10 lbs. 0 oz.	---	10 lbs. 0 oz.
		Circuit 3	10 lbs. 0 oz.	---	10 lbs. 0 oz.
		Circuit 4	8 lbs. 12 oz.	---	8 lbs. 12 oz.
	Conventional Fin/Tube With Humiditrol®	Circuit 1	12 lbs. 0 oz.	---	12 lbs. 0 oz.
		Circuit 2	12 lbs. 0 oz.	---	12 lbs. 0 oz.
		Circuit 3	10 lbs. 0 oz.	---	10 lbs. 0 oz.
Circuit 4		8 lbs. 12 oz.	---	8 lbs. 12 oz.	
Gas Heating Options Available			Page 14		
Compressor Type (number)			Scroll (4)	Scroll (4)	Scroll (4)
Outdoor Coils	Net face area (total) - sq. ft.		55.2	55.2	55.2
	Environ™ (Fin/Tube)	Number of rows Fins per inch	1 (2) 23 (20)	1 (2) 23 (20)	1 (2) 23 (20)
Outdoor Coil Fans	Motor - (No.) horsepower		(6) 1/3	(6) 1/3	(6) 1/3
	Motor rpm - Total Motor watts		1075 - 1950	1075 - 1950	1075 - 1950
	Diameter - (No.) in. - No. of blades		(6) 24 - 3	(6) 24 - 3	(6) 24 - 3
	Total Air volume - cfm		20,000	20,000	20,000
Indoor Coils	Net face area (total) - sq. ft.		21.4	21.4	21.4
	Tube diameter - in.		3/8	3/8	3/8
	Number of rows		4	4	4
	Fins per inch		14	14	14
	Drain connection - No. and size		(1) 1 in. FPT	(1) 1 in. FPT	(1) 1 in. FPT
	Expansion device type	Balance port TXV, removable head			
³ Indoor Blower and Drive Selection	Nominal motor output	5 hp, 7.5 hp, 10 hp			
	Maximum usable motor output (US Only)	5.75 hp, 8.62 hp, 11.5 hp			
	Motor - Drive kit number	5 hp Kit 3 685-856 rpm Kit 4 850-1045 rpm Kit 5 945-1185 rpm 7.5 hp Kit 6 850-1045 rpm Kit 7 945-1185 rpm Kit 8 1045-1285 rpm 10 hp Kit 7 945-1185 rpm Kit 10 1045-1285 rpm Kit 11 1135-1365 rpm			
	Blower wheel nom. D x W - in.	(2) 15 x 15			
Filters	Type of filter	Fiberglass, disposable			
	Number and size - in.	(6) 24 x 24 x 2			
Electrical characteristics			208/230V, 460V or 575V - 60 hertz - 3 phase		

NOTE - Net capacity includes evaporator blower motor heat deduction. Gross capacity does not include evaporator blower motor heat deduction.

¹ AHRI Certified to AHRI Standard 340/360; 95°F outdoor air temperature and 80°F db/67°F wb entering evaporator air; minimum external duct static pressure.

² Integrated Energy Efficiency Ratio tested according to AHRI Standard 340/360.

³ Using total air volume and system static pressure requirements determine from blower performance tables rpm and motor output required. Maximum usable output of motors furnished are shown. In Canada, nominal motor output is also maximum usable motor output. If motors of comparable output are used, be sure to keep within the service factor limitations outlined on the motor nameplate.

NOTE - Units equipped with MSAV® (Multi-Stage Air Volume) option are limited to a motor service factor of 1.0.

SPECIFICATIONS

General Data		Nominal Tonnage	25 Ton	25 Ton
		Model Number	LGH300S4B	LGH300S4M
Efficiency Type		Blower Type	Standard	Standard
		Blower Type	CAV (Constant Air Volume)	MSAV® (Multi-Stage Air Volume)
Cooling Performance	Gross Cooling Capacity - Btuh		281,000	281,000
	¹ Net Cooling Capacity - Btuh		270,000	270,000
	AHRI Rated Air Flow - cfm		8400	8400
	Total Unit Power - kW		25.7	25.7
	¹ EER (Btuh/Watt)		10.5	10.5
	² IEER (Btuh/Watt)		11.6	13.8
Refrigerant Charge		Refrigerant Type	R-410A	R-410A
Charge	Environ™ Coil System	Circuit 1	6 lbs. 4 oz.	6 lbs. 4 oz.
		Circuit 2	5 lbs. 10 oz.	5 lbs. 10 oz.
		Circuit 3	6 lbs. 6 oz.	6 lbs. 6 oz.
		Circuit 4	6 lbs. 0 oz.	6 lbs. 0 oz.
	Environ™ Coil System with Humiditrol®	Circuit 1	7 lbs. 8 oz.	7 lbs. 8 oz.
		Circuit 2	6 lbs. 4 oz.	6 lbs. 4 oz.
		Circuit 3	6 lbs. 2 oz.	6 lbs. 2 oz.
		Circuit 4	5 lbs. 14 oz.	5 lbs. 14 oz.
	Conventional Fin/Tube Coil Option	Circuit 1	10 lbs. 8 oz.	10 lbs. 8 oz.
		Circuit 2	10 lbs. 0 oz.	10 lbs. 0 oz.
		Circuit 3	9 lbs. 12 oz.	9 lbs. 12 oz.
		Circuit 4	9 lbs. 12 oz.	9 lbs. 12 oz.
	Conventional Fin/Tube With Humiditrol®	Circuit 1	12 lbs. 12 oz.	12 lbs. 12 oz.
		Circuit 2	11 lbs. 12 oz.	11 lbs. 12 oz.
		Circuit 3	9 lbs. 12 oz.	9 lbs. 12 oz.
		Circuit 4	9 lbs. 12 oz.	9 lbs. 12 oz.
Gas Heating Options Available			Page 14	
Compressor Type (number)			Scroll (4)	Scroll (4)
Outdoor Coils	Net face area (total) - sq. ft.		55.2	55.2
	Environ™ (Fin/Tube)	Number of rows	1 (2)	1 (2)
Fins per inch			23 (20)	23 (20)
Outdoor Coil Fans	Motor - (No.) horsepower		(6) 1/3	(6) 1/3
	Motor rpm - Total Motor watts		1075 - 1950	1075 - 1950
	Diameter - (No.) in. - No. of blades		(6) 24 - 3	(6) 24 - 3
	Total Air volume - cfm		20,000	20,000
Indoor Coils	Net face area (total) - sq. ft.		21.4	21.4
	Tube diameter - in.		3/8	3/8
	Number of rows		4	4
	Fins per inch		14	14
	Drain connection - No. and size		(1) 1 in. FPT	(1) 1 in. FPT
	Expansion device type		Balance port TXV, removable head	
³ Indoor Blower and Drive Selection	Nominal motor output		5 hp, 7.5 hp, 10 hp	
	Maximum usable motor output (US Only)		5.75 hp, 8.62 hp, 11.5 hp	
	Motor - Drive kit number		5 hp Kit 3 685-856 rpm Kit 4 850-1045 rpm Kit 5 945-1185 rpm 7.5 hp Kit 6 850-1045 rpm Kit 7 945-1185 rpm Kit 8 1045-1285 rpm 10 hp Kit 7 945-1185 rpm Kit 10 1045-1285 rpm Kit 11 1135-1365 rpm	
	Blower wheel nom. D x W - in.		(2) 15 x 15	
Filters	Type of filter		Fiberglass, disposable	
	Number and size - in.		(6) 24 x 24 x 2	
Electrical characteristics			208/230V, 460V or 575V - 60 hertz - 3 phase	

NOTE - Net capacity includes evaporator blower motor heat deduction. Gross capacity does not include evaporator blower motor heat deduction.

¹ AHRI Certified to AHRI Standard 340/360; 95°F outdoor air temperature and 80°F db/67°F wb entering evaporator air; minimum external duct static pressure.

² Integrated Energy Efficiency Ratio tested according to AHRI Standard 340/360.

³ Using total air volume and system static pressure requirements determine from blower performance tables rpm and motor output required. Maximum usable output of motors furnished are shown. In Canada, nominal motor output is also maximum usable motor output. If motors of comparable output are used, be sure to keep within the service factor limitations outlined on the motor nameplate.

NOTE - Units equipped with MSAV® (Multi-Stage Air Volume) option are limited to a motor service factor of 1.0.

SPECIFICATIONS

General Data		Nominal Tonnage	15 Ton	20 Ton	25 Ton
	Model Number		LGH180U4M	LGH240U4M	LGH300U4M
	Efficiency Type		Ultra	Ultra	Ultra
	Blower Type		MSAV (Multi-Stage Air Volume)	MSAV (Multi-Stage Air Volume)	MSAV (Multi-Stage Air Volume)
Cooling Performance	Gross Cooling Capacity - Btuh		185,300	241,000	272,000
	¹ Net Cooling Capacity - Btuh		180,000	234,000	265,000
	AHRI Rated Air Flow - cfm		5,200	6400	8400
	Total Unit Power - kW		14.2	19.5	25.2
	¹ EER (Btuh/Watt)		12.7	12.0	10.5
	² IEER (Btuh/Watt)		20.2	20.0	17.5
Refrigerant Charge	Refrigerant Type		R-410A	R-410A	R-410A
	Circuit 1		20 lbs. 0 oz.	21 lbs. 4 oz.	23 lbs. 8 oz.
	Circuit 2		20 lbs. 8 oz.	22 lbs. 0 oz.	21 lbs. 0 oz.
Gas Heating Options Available		See page 14>			
Compressor Type (number)			Tandem Scroll (4)	Tandem Scroll (4)	Tandem Scroll (4)
Outdoor Coils	Net face area (total) - sq. ft.		55.2	55.2	55.2
	Tube Diameter - in.		3/8	3/8	3/8
	Number of rows		2	2	2
	Fins per inch		20	20	20
Outdoor Coil Fans	Motor - (No.) horsepower		(6) 1/3 ECM	(6) 1/3 ECM	(6) 1/3 ECM
	Motor rpm		530 - 895	590 - 955	590 - 955
	Total Motor watts		210 - 860	555 - 1740	555 - 1740
	Diameter - (No.) in.		(6) 24	(6) 24	(6) 24
	Number of blades		3	3	3
	Total Air volume - cfm		16,000	19,500	19,500
Indoor Coils	Net face area (total) - sq. ft.		21.4	21.4	21.4
	Tube diameter - in.		3/8	3/8	3/8
	Number of rows		4	4	3
	Fins per inch		14	14	14
	Drain connection - No. and size		(1) 1 in. FPT	(1) 1 in. FPT	(1) 1 in. FPT
	Expansion device type		Balance port TXV, removable head		
³ Indoor Blower and Drive Selection	Nominal motor output		3 hp, 5 hp, 7.5 hp	5 hp, 7.5 hp, 10 hp	
	Maximum usable motor output (US Only)		3.45 hp, 5.75 hp, 8.62 hp	5.75 hp, 8.62 hp, 11.5 hp	
	Motor - Drive kit number		3 hp Std. Eff. Kit 1 535-725 rpm Kit 2 710-965 rpm 3 hp High. Eff. Kit 3 - 685-856 rpm Kit 4 850-1045 rpm 5 hp Kit 3 685-856 rpm Kit 4 850-1045 rpm Kit 5 945-1185 rpm 7.5 hp Kit 6 850-1045 rpm Kit 7 945-1185 rpm Kit 8 1045-1285 rpm	5 hp Kit 3 685-856 rpm Kit 4 850-1045 rpm Kit 5 945-1185 rpm 7.5 hp Kit 6 850-1045 rpm Kit 7 945-1185 rpm Kit 8 1045-1285 rpm 10 hp Kit 7 945-1185 rpm Kit 10 1045-1285 rpm Kit 11 1135-1365 rpm	5 hp Kit 3 685-856 rpm Kit 4 850-1045 rpm Kit 5 945-1185 rpm 7.5 hp Kit 6 850-1045 rpm Kit 7 945-1185 rpm Kit 8 1045-1285 rpm 10 hp Kit 7 945-1185 rpm Kit 10 1045-1285 rpm Kit 11 1135-1365 rpm
	Blower wheel nominal D x W - in.		(2) 15 x 15	(2) 15 x 15	(2) 15 x 15
Filters	Type of filter	Fiberglass, disposable			
	Number and size - in.	(6) 24 x 24 x 2			
Electrical characteristics		208/230V, 460V or 575V - 60 hertz - 3 phase			

NOTE - Net capacity includes evaporator blower motor heat deduction. Gross capacity does not include evaporator blower motor heat deduction.

¹ AHRI Certified to AHRI Standard 340/360; 95°F outdoor air temperature and 80°F db/67°F wb entering evaporator air; minimum external duct static pressure.

² Integrated Energy Efficiency Ratio tested according to AHRI Standard 340/360.

³ Using total air volume and system static pressure requirements determine from blower performance tables rpm and motor output required. Maximum usable output of motors furnished are shown. In Canada, nominal motor output is also maximum usable motor output. If motors of comparable output are used, be sure to keep within the service factor limitations outlined on the motor nameplate.

NOTE – MSAV® (Multi-Stage Air Volume) drive is limited to a motor service factor of 1.0.

SPECIFICATIONS - GAS HEAT

Usage Data		Model Number	LGH156 LGH180 LGH210	LGH156 LGH180 LGH210 LGH240 LGH300	LGH180 LGH210 LGH240 LGH300	
		Heat Input Type	Low (L)	Standard (S)	Medium (M)	High (H)
		Number of Gas Heat Stages	1	2	2	2
Gas Heating Performance (Two-Stage)	Input - Btuh	First Stage	169,000	169,000	234,000	312,000
		Second Stage	N/A	260,000	360,000	480,000
	Output - Btuh	First Stage	135,000	---	---	---
		Second Stage	N/A	208,000	288,000	384,000
¹ Gas Heating Performance (Four-Stage)	Input - Btuh	First Stage	N/A	84,500	117,000	156,000
		Second Stage	N/A	169,000	234,000	312,000
		Third Stage	N/A	214,000	297,000	396,000
		Fourth Stage	N/A	260,000	360,000	480,000
	Output - Btuh	First Stage	135,000	---	---	---
		Second Stage	N/A	---	---	---
		Third Stage	N/A	---	---	---
		Fourth Stage	N/A	208,000	288,000	384,000
Temperature Rise Range - °F		15 - 45	15 - 45	30 - 60	40 - 70	
Thermal Efficiency		80.0%	80.0%	80.0%	80.0%	
Gas Supply Connections		1 in. npt	1 in. npt	1 in. npt	1 in. npt	
Recommended Gas Supply Pressure - in. w.g.	Natural	7	7	7	7	
	LPG/Propane	11	11	11	11	

¹ Four-stage gas heating is enabled when zone sensor, Discharge Air Control, or fresh air tempering mode is selected. (Available when using the CS8500 thermostat or when connected to Building Automation Systems using BACnet, LonTalk, or S-Bus protocols)

HIGH ALTITUDE DERATE

Units may be installed at altitudes up to 2000 feet above sea level without any modification.

At altitudes above 2000 feet, units must be derated to match gas manifold pressures shown in table below.

At altitudes above 4500 feet unit must be derated 2% for each 1000 feet above sea level.

NOTE – This is the only permissible derate for these units.

TWO-STAGE

Gas Heat Type (Two-Stage)	Altitude - ft.	Gas Manifold Pressure - in. w.g.		Input Rate Natural Gas or LPG/Propane - Btuh	
		Natural Gas	LPG/Propane Gas	First Stage	Second Stage
Low (L)	No adjustment required				
Standard (S)	2001 - 4500	3.4	9.6	169,000	249,000
Medium (M)	2001 - 4500	3.4	9.6	234,000	345,000
High (H)	2001 - 4500	3.4	9.6	312,000	460,000

FOUR-STAGE

¹ Gas Heat Type (Four-Stage)	Altitude - ft.	Gas Manifold Pressure - in. w.g.		Input Rate Natural Gas or LPG/Propane - Btuh			
		Natural Gas	LPG/Propane Gas	First Stage	Second Stage	Third Stage	Fourth Stage
Low (L)	No adjustment required						
Standard (S)	2001 - 4500	3.4	9.6	84,000	169,000	209,000	249,000
Medium (M)	2001 - 4500	3.4	9.6	117,000	234,000	289,000	345,000
High (H)	2001 - 4500	3.4	9.6	156,000	312,000	386,000	460,000

¹ Four-Stage Gas Heating is field configured.

BLOWER DATA

FACTORY INSTALLED BELT DRIVE KIT SPECIFICATIONS

Motor Efficiency	Nominal hp	Maximum hp	Drive Kit Number	RPM Range
Standard or High	2	2.30	1	535 - 725
Standard or High	2	2.30	2	710 - 965
Standard	3	3.45	1	535 - 725
Standard	3	3.45	2	710 - 965
High	3	3.45	3	685 - 856
High	3	3.45	4	850 - 1045
Standard	5	5.75	3	685 - 856
Standard	5	5.75	4	850 - 1045
Standard	5	5.75	5	945 - 1185
Standard	7.5	8.63	6	850 - 1045
Standard	7.5	8.63	7	945 - 1185
Standard	7.5	8.63	8	1045 - 1285
Standard	10	11.50	7	945 - 1185
Standard	10	11.50	10	1045 - 1285
Standard	10	11.50	11	1135 - 1365

NOTE - Using total air volume and system static pressure requirements determine from blower performance tables rpm and motor output required. Maximum usable output of motors furnished are shown. In Canada, nominal motor output is also maximum usable motor output. If motors of comparable output are used, be sure to keep within the service factor limitations outlined on the motor nameplate.

NOTE - Units equipped with MSAV® (Multi-Stage Air Volume) option are limited to a motor service factor of 1.0.

FACTORY INSTALLED OPTIONS/FIELD INSTALLED ACCESSORY AIR RESISTANCE

Air Volume cfm	Wet Indoor Coil		Humiditrol® Condenser Reheat Coil	Gas Heat Exchanger			Economizer	Filters		Horizontal Roof Curb	
	156H, 180H	210H, 240H, 300S		Low/Standard Heat	Medium Heat	High Heat		MERV 8	MERV 13	156H thru 240H	300S
	in. w.g.	in. w.g.	in. w.g.	in. w.g.	in. w.g.	in. w.g.	in. w.g.			in. w.g.	
2750	.01	.02	.01	.02	.04	.05	---	.01	.03	.03	-
3000	.01	.02	.01	.03	.04	.05	---	.01	.03	.04	-
3250	.01	.03	.01	.03	.05	.06	---	.01	.04	.04	.01
3500	.01	.03	.02	.03	.05	.06	---	.01	.04	.05	.01
3750	.01	.03	.02	.04	.06	.07	---	.01	.04	.05	.01
4000	.02	.04	.02	.04	.06	.07	---	.01	.04	.06	.02
4250	.02	.04	.02	.04	.06	.08	---	.01	.05	.07	.02
4500	.02	.05	.02	.05	.07	.09	---	.01	.05	.07	.02
4750	.02	.05	.02	.05	.08	.10	---	.02	.05	.08	.03
5000	.02	.05	.02	.05	.09	.11	---	.02	.06	.08	.03
5250	.02	.06	.03	.06	.10	.12	---	.02	.06	.09	.04
5500	.02	.07	.03	.06	.10	.13	---	.02	.06	.10	.04
5750	.03	.07	.03	.06	.11	.14	---	.02	.07	.11	.05
6000	.03	.08	.03	.07	.12	.15	---	.03	.07	.11	.06
6250	.03	.08	.03	.07	.12	.16	.01	.03	.07	.12	.07
6500	.03	.09	.04	.08	.13	.17	.02	.03	.08	.13	.08
6750	.04	.10	.04	.08	.14	.18	.03	.03	.08	.14	.08
7000	.04	.10	.04	.09	.15	.19	.04	.04	.08	.15	.09
7250	.04	.11	.04	.09	.16	.20	.05	.04	.09	.16	.10
7500	.05	.12	.05	.10	.17	.21	.06	.04	.09	.17	.11
8000	.05	.13	.05	.11	.19	.24	.09	.05	.10	.19	.13
8500	.06	.15	.05	.12	.20	.26	.11	.05	.10	.21	.15
9000	.07	.16	.06	.13	.23	.29	.14	.06	.11	.24	.17
9500	.08	.18	.07	.14	.25	.32	.16	.07	.12	.26	.19
10,000	.08	.20	.07	.16	.27	.35	.19	.07	.12	.29	.21
10,500	.09	.22	.08	.17	.30	.38	.22	.08	.13	.31	.24
11,000	.11	.24	.08	.18	.31	.40	.25	.09	.14	.34	.27

BLOWER DATA

POWER EXHAUST FAN PERFORMANCE

Return Air System Static Pressure	Air Volume Exhausted
in. w.g.	cfm
0.00	8630
0.05	8210
0.10	7725
0.15	7110
0.20	6470
0.25	5790
0.30	5060
0.35	4300
0.40	3510
0.45	2690
0.50	1840

CEILING DIFFUSER AIR RESISTANCE - in. w.g.

Air Volume cfm	Step-Down Diffuser						Flush Diffuser	
	RTD11-185S			RTD11-275S			FD11-185S	FD11-275S
	2 Ends Open	1 Side/2 Ends Open	All Ends & Sides Open	2 Ends Open	1 Side/2 Ends Open	All Ends & Sides Open		
5000	.51	.44	.39	---	---	---	.27	---
5200	.56	.48	.42	---	---	---	.30	---
5400	.61	.52	.45	---	---	---	.33	---
5600	.66	.56	.48	---	---	---	.36	---
5800	.71	.59	.51	---	---	---	.39	---
6000	.76	.63	.55	.36	.31	.27	.42	.29
6200	.80	.68	.59	---	---	---	.46	---
6400	.86	.72	.63	---	---	---	.50	---
6500	---	---	---	.42	.36	.31	---	.34
6600	.92	.77	.67	---	---	---	.54	---
6800	.99	.83	.72	---	---	---	.58	---
7000	1.03	.87	.76	.49	.41	.36	.62	.40
7200	1.09	.92	.80	---	---	---	.66	---
7400	1.15	.97	.84	---	---	---	.70	---
7500	---	---	---	.51	.46	.41	---	.45
7600	1.20	1.02	.88	---	---	---	.74	---
8000	---	---	---	.59	.49	.43	---	.50
8500	---	---	---	.69	.58	.50	---	.57
9000	---	---	---	.79	.67	.58	---	.66
9500	---	---	---	.89	.75	.65	---	.74
10,000	---	---	---	1.00	.84	.73	---	.81
10,500	---	---	---	1.10	.92	.80	---	.89
11,000	---	---	---	1.21	1.01	.88	---	.96

CEILING DIFFUSER AIR THROW DATA - ft.

Model No.	Air Volume cfm	¹ Effective Throw Range - ft.		Model No.	Air Volume cfm	¹ Effective Throw Range - ft.	
		RTD11-185S Step-Down	FD11-185S Flush			RTD11-275S Step-Down	FD11-275S Flush
156 180	5600	39 - 49	28 - 37	210 240 300	7200	33 - 38	26 - 35
	5800	42 - 51	29 - 38		7400	35 - 40	28 - 37
	6000	44 - 54	40 - 50		7600	36 - 41	29 - 38
	6200	45 - 55	42 - 51		7800	38 - 43	40 - 50
	6400	46 - 55	43 - 52		8000	39 - 44	42 - 51
	6600	47 - 56	45 - 56		8200	41 - 46	43 - 52
					8400	43 - 49	44 - 54
					8600	44 - 50	46 - 57
					8800	47 - 55	48 - 59

¹ Throw is the horizontal or vertical distance an airstream travels on leaving the outlet diffuser before the maximum velocity is reduced to 50 ft. per minute. Four sides open.

ELECTRICAL DATA**13 TON****13 TON HIGH EFFICIENCY****LGH156H4**

¹ Voltage - 60hz		208/230V - 3 Ph			460V - 3 Ph			575V - 3 Ph		
Compressor 1	Rated Load Amps	14.5			6.3			6		
	Locked Rotor Amps	98			55			41		
Compressor 2	Rated Load Amps	14.5			6.3			6		
	Locked Rotor Amps	98			55			41		
Compressor 3	Rated Load Amps	14.5			6.3			6		
	Locked Rotor Amps	98			55			41		
Outdoor Fan Motors (3)	Full Load Amps	2.4			1.3			1		
	(total)	(7.2)			(3.9)			(3)		
Power Exhaust (2) 0.33 HP	Full Load Amps	2.4			1.3			1		
	(total)	(4.8)			(2.6)			(2)		
Service Outlet 115V GFI (amps)		15			15			20		
Indoor Blower Motor	Horsepower	2	3	5	2	3	5	2	3	5
	Full Load Amps	7.5	10.6	16.7	3.4	4.8	7.6	2.7	3.9	6.1
² Maximum Overcurrent Protection	Unit Only	70	70	80	30	35	35	30	30	30
	With (2) 0.33 HP Power Exhaust	80	80	90	35	35	40	30	30	35
³ Minimum Circuit Ampacity	Unit Only	62	65	72	28	30	33	26	27	29
	With (2) 0.33 HP Power Exhaust	67	70	77	31	32	35	28	29	31

ELECTRICAL DATA**15 TON****15 TON HIGH EFFICIENCY****LGH180H4**

¹ Voltage - 60hz		208/230V - 3 Ph			460V - 3 Ph			575V - 3 Ph		
Compressor 1	Rated Load Amps	13.2			6.3			4.9		
	Locked Rotor Amps	93			60			41		
Compressor 2	Rated Load Amps	13.2			6.3			4.9		
	Locked Rotor Amps	93			60			41		
Compressor 3	Rated Load Amps	13.2			6.3			4.9		
	Locked Rotor Amps	93			60			41		
Outdoor Fan Motors (4)	Full Load Amps	2.4			1.3			1		
	(total)	(9.6)			(5.2)			(4)		
Power Exhaust (2) 0.33 HP	Full Load Amps	2.4			1.3			1		
	(total)	(4.8)			(2.6)			(2)		
Service Outlet 115V GFI (amps)		15			15			20		
Indoor Blower Motor	Horsepower	3	5	7.5	3	5	7.5	3	5	7.5
	Full Load Amps	10.6	16.7	24.2	4.8	7.6	11	3.9	6.1	9
² Maximum Overcurrent Protection	Unit Only	70	80	100	35	40	45	25	30	35
	With (2) 0.33 HP Power Exhaust	80	90	100	35	40	50	30	30	40
³ Minimum Circuit Ampacity	Unit Only	64	71	80	31	34	38	24	27	30
	With (2) 0.33 HP Power Exhaust	68	75	85	34	37	41	26	29	32

NOTE - All units have a minimum Short Circuit Current Rating (SCCR) of 5000 amps.

¹ Extremes of operating range are plus and minus 10% of line voltage.² HACR type breaker or fuse.³ Refer to National or Canadian Electrical Code manual to determine wire, fuse and disconnect size requirements.⁴ Factory installed circuit breaker not available.

ELECTRICAL DATA

17.5 TON

17.5 TON HIGH EFFICIENCY

LGH210H4

¹ Voltage - 60hz		208/230V - 3 Ph			460V - 3 Ph			575V - 3 Ph		
Compressor 1	Rated Load Amps	15.6			7.8			5.8		
	Locked Rotor Amps	110			52			38.9		
Compressor 2	Rated Load Amps	15.6			7.8			5.8		
	Locked Rotor Amps	110			52			38.9		
Compressor 3	Rated Load Amps	19.6			8.2			6.6		
	Locked Rotor Amps	136			66.1			55.3		
Outdoor Fan Motors (6)	Full Load Amps (total)	2.4 (14.4)			1.3 (7.8)			1 (6)		
Power Exhaust (2) 0.33 HP	Full Load Amps (total)	2.4 (4.8)			1.3 (2.6)			1 (2)		
Service Outlet 115V GFI (amps)		15			15			20		
Indoor Blower Motor	Horsepower	3	5	7.5	3	5	7.5	3	5	7.5
	Full Load Amps	10.6	16.7	24.2	4.8	7.6	11	3.9	6.1	9
² Maximum Overcurrent Protection	Unit Only	100	100	110	45	45	50	35	35	40
	With (2) 0.33 HP Power Exhaust	100	110	110	45	50	50	35	40	45
³ Minimum Circuit Ampacity	Unit Only	81	87	96	39	42	46	30	32	36
	With (2) 0.33 HP Power Exhaust	86	92	101	42	44	48	32	34	38

ELECTRICAL DATA

20 TON

20 TON HIGH EFFICIENCY

LGH240H4

¹ Voltage - 60hz		208/230V - 3 Ph			460V - 3 Ph			575V - 3 Ph		
Compressor 1	Rated Load Amps	13.2			6.3			4.9		
	Locked Rotor Amps	93			60			41		
Compressor 2	Rated Load Amps	13.2			6.3			4.9		
	Locked Rotor Amps	93			60			41		
Compressor 3	Rated Load Amps	13.2			6.3			4.9		
	Locked Rotor Amps	93			60			41		
Compressor 4	Rated Load Amps	13.2			6.3			4.9		
	Locked Rotor Amps	93			60			41		
Outdoor Fan Motors (6)	Full Load Amps (total)	2.4 (14.4)			1.3 (7.8)			1 (6)		
Power Exhaust (2) 0.33 HP	Full Load Amps (total)	2.4 (4.8)			1.3 (2.6)			1 (2)		
Service Outlet 115V GFI (amps)		15			15			20		
Indoor Blower Motor	Horsepower	5	7.5	10	5	7.5	10	5	7.5	10
	Full Load Amps	16.7	24.2	30.8	7.6	11	14	6.1	9	11
² Maximum Overcurrent Protection	Unit Only	100	110	125	50	50	60	35	45	50
	With (2) 0.33 HP Power Exhaust	100	125	125	50	60	60	40	45	50
³ Minimum Circuit Ampacity	Unit Only	89	98	106	43	47	51	34	37	40
	With (2) 0.33 HP Power Exhaust	93	103	111	46	50	54	36	39	42

NOTE - All units have a minimum Short Circuit Current Rating (SCCR) of 5000 amps.

¹ Extremes of operating range are plus and minus 10% of line voltage.² HACR type breaker or fuse.³ Refer to National or Canadian Electrical Code manual to determine wire, fuse and disconnect size requirements.⁴ Factory installed circuit breaker not available.

ELECTRICAL DATA

25 TON

25 TON STANDARD EFFICIENCY

LGH300S4

¹ Voltage - 60hz		208/230V - 3 Ph			460V - 3 Ph			575V - 3 Ph		
Compressor 1	Rated Load Amps	19.6			8.2			6.6		
	Locked Rotor Amps	136			66.1			55.3		
Compressor 2	Rated Load Amps	19.6			8.2			6.6		
	Locked Rotor Amps	136			66.1			55.3		
Compressor 3	Rated Load Amps	22.4			10.6			7.7		
	Locked Rotor Amps	149			75			54		
Compressor 4	Rated Load Amps	22.4			10.6			7.7		
	Locked Rotor Amps	149			75			54		
Outdoor Fan Motors (6)	Full Load Amps (total)	2.4 (14.4)			1.3 (7.8)			1 (6)		
Power Exhaust (2) 0.33 HP	Full Load Amps (total)	2.4 (4.8)			1.3 (2.6)			1 (2)		
Service Outlet 115V GFI (amps)		15			15			20		
Indoor Blower Motor	Horsepower	5	7.5	10	5	7.5	10	5	7.5	10
	Full Load Amps	16.7	24.2	30.8	7.6	11	14	6.1	9	11
² Maximum Overcurrent Protection	Unit Only	125	150	150	60	70	70	50	50	50
	With (2) 0.33 HP Power Exhaust	150	150	150	60	70	70	50	50	60
³ Minimum Circuit Ampacity	Unit Only	121	129	137	56	60	63	45	46	49
	With (2) 0.33 HP Power Exhaust	126	134	142	59	62	66	45	48	51

NOTE - All units have a minimum Short Circuit Current Rating (SCCR) of 5000 amps.

¹ Extremes of operating range are plus and minus 10% of line voltage.

² HACR type breaker or fuse.

³ Refer to National or Canadian Electrical Code manual to determine wire, fuse and disconnect size requirements.

⁴ Factory installed circuit breaker not available.

ELECTRICAL ACCESSORIES

DISCONNECTS

Voltage	208V	240V	208V	240V	208V	240V	460V	460V	460V	575V	575V	575V
Model No.	LGH156H4											
Blower Motor HP	2		3		5		2	3	5	2	3	5
Unit Only	54W88	54W88	54W88	54W88	54W88	54W88	54W88	54W88	54W88	54W88	54W88	54W88
Unit w/ Power Exhaust	54W88	54W88	54W88	54W88	54W88	54W88	54W88	54W88	54W88	54W88	54W88	54W88
Model No.	LGH180H4											
Blower Motor HP	3		5		7.5		3	5	7.5	3	5	7.5
Unit Only	54W88	54W88	54W88	54W88	54W89	54W89	54W88	54W88	54W88	54W88	54W88	54W88
Unit w/ Power Exhaust	54W88	54W88	54W89	54W89	54W89	54W89	54W88	54W88	54W88	54W88	54W88	54W88
Model No.	LGH210H4											
Blower Motor HP	3		5		7.5		3	5	7.5	3	5	7.5
Unit Only	54W89	54W89	54W89	54W89	54W89	54W89	54W88	54W88	54W88	54W88	54W88	54W88
Unit w/ Power Exhaust	54W89	54W89	54W89	54W89	54W89	54W89	54W88	54W88	54W88	54W88	54W88	54W88
Model No.	LGH240H4											
Blower Motor HP	5		7.5		10		5	7.5	10	5	7.5	10
Unit Only	54W89	54W89	54W89	54W89	54W89	54W89	54W88	54W88	54W88	54W88	54W88	54W88
Unit w/ Power Exhaust	54W89	54W89	54W89	54W89	54W89	54W89	54W88	54W88	54W88	54W88	54W88	54W88
Model No.	LGH300S4											
Blower Motor HP	5		7.5		10		5	7.5	10	5	7.5	10
Unit Only	54W89	54W89	54W89	54W89	54W89	54W89	54W88	54W88	54W88	54W88	54W88	54W88
Unit w/ Power Exhaust	54W89	54W89	54W89	54W89	90W82	90W82	54W88	54W88	54W88	54W88	54W88	54W88

ELECTRICAL DATA **15 TON**

15 TON ULTRA HIGH EFFICIENCY (R-410A) LGH180U4M

¹ Voltage - 60hz		208/230V - 3 Ph			460V - 3 Ph			575V - 3 Ph		
Compressor 1	Rated Load Amps	13.1			6.1			4.4		
	Locked Rotor Amps	83.1			41			33		
Compressor 2	Rated Load Amps	13.1			6.1			4.4		
	Locked Rotor Amps	83.1			41			33		
Compressor 3	Rated Load Amps	13.1			6.1			4.4		
	Locked Rotor Amps	83.1			41			33		
Compressor 4	Rated Load Amps	13.1			6.1			4.4		
	Locked Rotor Amps	83.1			41			33		
Outdoor Fan Motors (6)	Full Load Amps (total)	2.8 (16.8)			1.4 (8.4)			1.1 (6.6)		
Power Exhaust (2) 0.33 HP	Full Load Amps (total)	2.4 (4.8)			1.3 (2.6)			1 (2)		
Service Outlet 115V GFI (amps)		15			15			20		
Indoor Blower Motor	Horsepower	3	5	7.5	3	5	7.5	3	5	7.5
	Full Load Amps	10.6	16.7	24.2	4.8	7.6	11	3.9	6.1	9
² Maximum Overcurrent Protection	Unit Only	90	100	110	45	45	50	30	35	40
	With (2) 0.33 HP Power Exhaust	100	110	125	45	50	60	35	35	45
³ Minimum Circuit Ampacity	Unit Only	84	91	100	40	43	47	30	32	36
	With (2) 0.33 HP Power Exhaust	88	95	105	42	45	50	32	34	38

NOTE - All units have a minimum Short Circuit Current Rating (SCCR) of 5000 amps.

¹ Extremes of operating range are plus and minus 10% of line voltage.

² HACR type breaker or fuse.

³ Refer to National or Canadian Electrical Code manual to determine wire, fuse and disconnect size requirements.

ELECTRICAL DATA **20 TON**

20 TON ULTRA HIGH EFFICIENCY (R-410A) LGH240U4M

¹ Voltage - 60hz		208/230V - 3 Ph			460V - 3 Ph			575V - 3 Ph		
Compressor 1	Rated Load Amps	13.5			8			5		
	Locked Rotor Amps	109			59			40		
Compressor 2	Rated Load Amps	13.5			8			5		
	Locked Rotor Amps	109			59			40		
Compressor 3	Rated Load Amps	13.5			8			5		
	Locked Rotor Amps	109			59			40		
Compressor 4	Rated Load Amps	13.5			8			5		
	Locked Rotor Amps	109			59			40		
Outdoor Fan Motors (6)	Full Load Amps (total)	2.8 (16.8)			1.4 (8.4)			1.1 (6.6)		
Power Exhaust (2) 0.33 HP	Full Load Amps (total)	2.4 (4.8)			1.3 (2.6)			1 (2)		
Service Outlet 115V GFI (amps)		15			15			20		
Indoor Blower Motor	Horsepower	5	7.5	10	5	7.5	10	5	7.5	10
	Full Load Amps	16.7	24.2	30.8	7.6	11	14	6.1	9	11
² Maximum Overcurrent Protection	Unit Only	100	125	125	50	60	70	40	45	50
	With (2) 0.33 HP Power Exhaust	110	125	125	60	60	70	40	45	50
³ Minimum Circuit Ampacity	Unit Only	92	102	110	50	55	58	35	38	41
	With (2) 0.33 HP Power Exhaust	97	106	115	53	57	61	37	40	43

NOTE - All units have a minimum Short Circuit Current Rating (SCCR) of 5000 amps.

¹ Extremes of operating range are plus and minus 10% of line voltage.

² HACR type breaker or fuse.

³ Refer to National or Canadian Electrical Code manual to determine wire, fuse and disconnect size requirements.

⁴ Factory installed circuit breaker not available.

ELECTRICAL DATA

25 TON

25 TON ULTRA HIGH EFFICIENCY (R-410A)

LGH300U4M

¹ Voltage - 60hz		208/230V - 3 Ph			460V - 3 Ph			575V - 3 Ph		
Compressor 1	Rated Load Amps	19.6			8.2			6.6		
	Locked Rotor Amps	136			66.1			55.3		
Compressor 2	Rated Load Amps	19.6			8.2			6.6		
	Locked Rotor Amps	136			66.1			55.3		
Compressor 3	Rated Load Amps	19.6			8.2			6.6		
	Locked Rotor Amps	136			66.1			55.3		
Compressor 4	Rated Load Amps	19.6			8.2			6.6		
	Locked Rotor Amps	136			66.1			55.3		
Outdoor Fan Motors (6)	Full Load Amps (total)	2.8 (16.8)			1.4 (8.4)			1.1 (6.6)		
Power Exhaust (2) 0.33 HP	Full Load Amps (total)	2.4 (4.8)			1.3 (2.6)			1 (2)		
Service Outlet 115V GFI (amps)		15			15			20		
Indoor Blower Motor	Horsepower	5	7.5	10	5	7.5	10	5	7.5	10
	Full Load Amps	16.7	24.2	30.8	7.6	11	14	6.1	9	11
² Maximum Overcurrent Protection	Unit Only	125	150	150	60	60	70	45	50	50
	With (2) 0.33 HP Power Exhaust	125	150	150	60	60	70	45	50	50
³ Minimum Circuit Ampacity	Unit Only	117	126	134	51	55	59	59	45	47
	With (2) 0.33 HP Power Exhaust	122	131	139	54	58	62	62	47	49

NOTE - All units have a minimum Short Circuit Current Rating (SCCR) of 5000 amps.

¹ Extremes of operating range are plus and minus 10% of line voltage.

² HACR type breaker or fuse.

³ Refer to National or Canadian Electrical Code manual to determine wire, fuse and disconnect size requirements.

⁴ Factory installed circuit breaker not available.

ELECTRICAL ACCESSORIES

DISCONNECTS

Voltage	208V	230V	208V	230V	208V	230V	460V	460V	460V	575V	575V	575V
Model No.	LGH180U4M											
Blower Motor HP	3		5		7.5		3	5	7.5	3	5	7.5
Unit Only	54W88	54W88	54W88	54W88	54W89	54W89	54W88	54W88	54W88	54W88	54W88	54W88
Unit w/ Power Exhaust	54W88	54W88	54W89	54W89	54W89	54W89	54W88	54W88	54W88	54W88	54W88	54W88
Model No.	LGH240U4M											
Blower Motor HP	5		7.5		10		5	7.5	10	5	7.5	10
Unit Only	54W89	54W89	54W89	54W89	54W89	54W89	54W88	54W88	54W88	54W88	54W88	54W88
Unit w/ Power Exhaust	54W89	54W89	54W89	54W89	54W89	54W89	54W88	54W88	54W88	54W88	54W88	54W88
Model No.	LGH300U4M											
Blower Motor HP	5		7.5		10		5	7.5	10	5	7.5	10
Unit Only	54W89	54W89	54W89	54W89	54W89	54W89	54W88	54W88	54W88	54W88	54W88	54W88
Unit w/ Power Exhaust	54W89	54W89	54W89	54W89	54W89	54W89	54W88	54W88	54W88	54W88	54W88	54W88

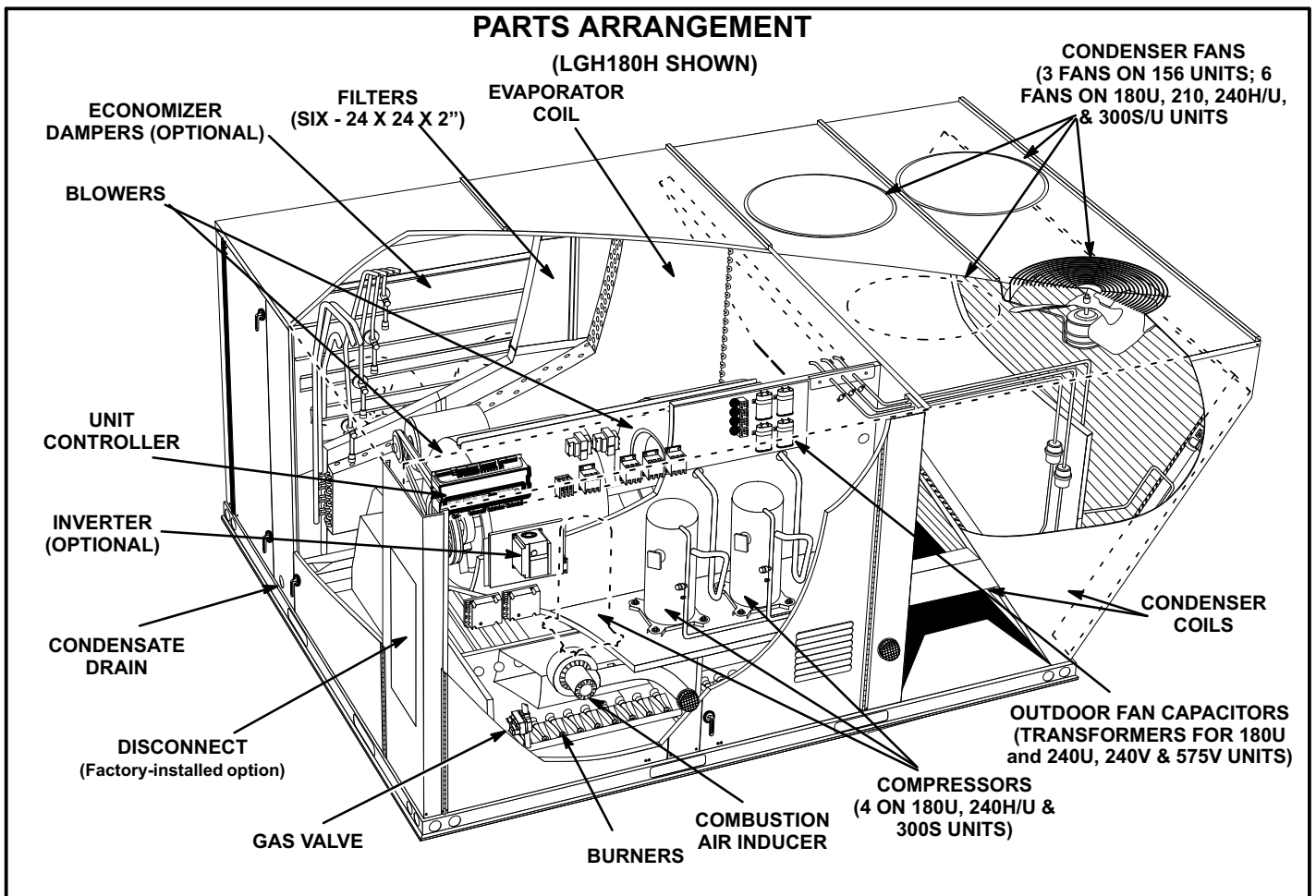

FIGURE 1

I-UNIT COMPONENTS

CAUTION

As with any mechanical equipment, contact with sharp sheet metal edges can result in personal injury. Take care while handling this equipment and wear gloves and protective clothing.

All 13 through 25 ton (45.7 through 88 kW) units are configured to order units (CTO). Unit components are shown in figures 1. All units come standard with hinged unit panels. The unit panels may be held open with the door rod located inside the unit. All L1, L2 and L3 wiring is color coded; L1 is red, L2 is yellow and L3 is blue.

A-Control Box Components

ELECTROSTATIC DISCHARGE (ESD)

Precautions and Procedures

CAUTION



Electrostatic discharge can affect electronic components. Take precautions to neutralize electrostatic charge by touching your hand and tools to metal prior to handling the control.

Control box components are shown in figure 3. The control box is located in the upper portion of the compressor compartment.

1-Disconnect Switch S48

Units with higher SCCR rating may be equipped with a disconnect switch S48. Other factory or field installed optional circuit breakers may be used, such as CB10. S48 and CB10 are toggle or twist-style switches, which can be used by the service technician to disconnect power to the unit.

2-Control Transformer T1

All use a single line voltage to 24VAC transformer mounted in the control box. Transformer supplies power to control circuits in the unit. The transformer is rated at 70VA and is protected by a 3.5 amp circuit breaker (CB8). The 208/230 (Y) voltage transformers use two

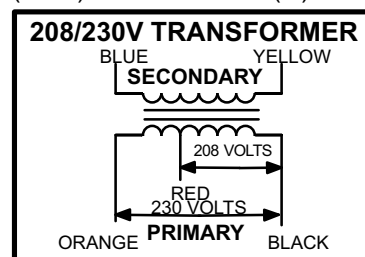

FIGURE 2

primary voltage taps as shown in figure 2, while 460 (G) and 575 (J) voltage transformers use a single primary voltage tap.

3-Contactor Transformer T18

T18 is a single line voltage to 24VAC transformer used in all LGH 13 to 25 ton units. Transformer T18 is protected by a 3.5 amp circuit breaker (CB18). T18 is identical to transformer T1. The transformer supplies 24VAC power to the contactors.

CONTROL BOX PARTS ARRANGEMENT

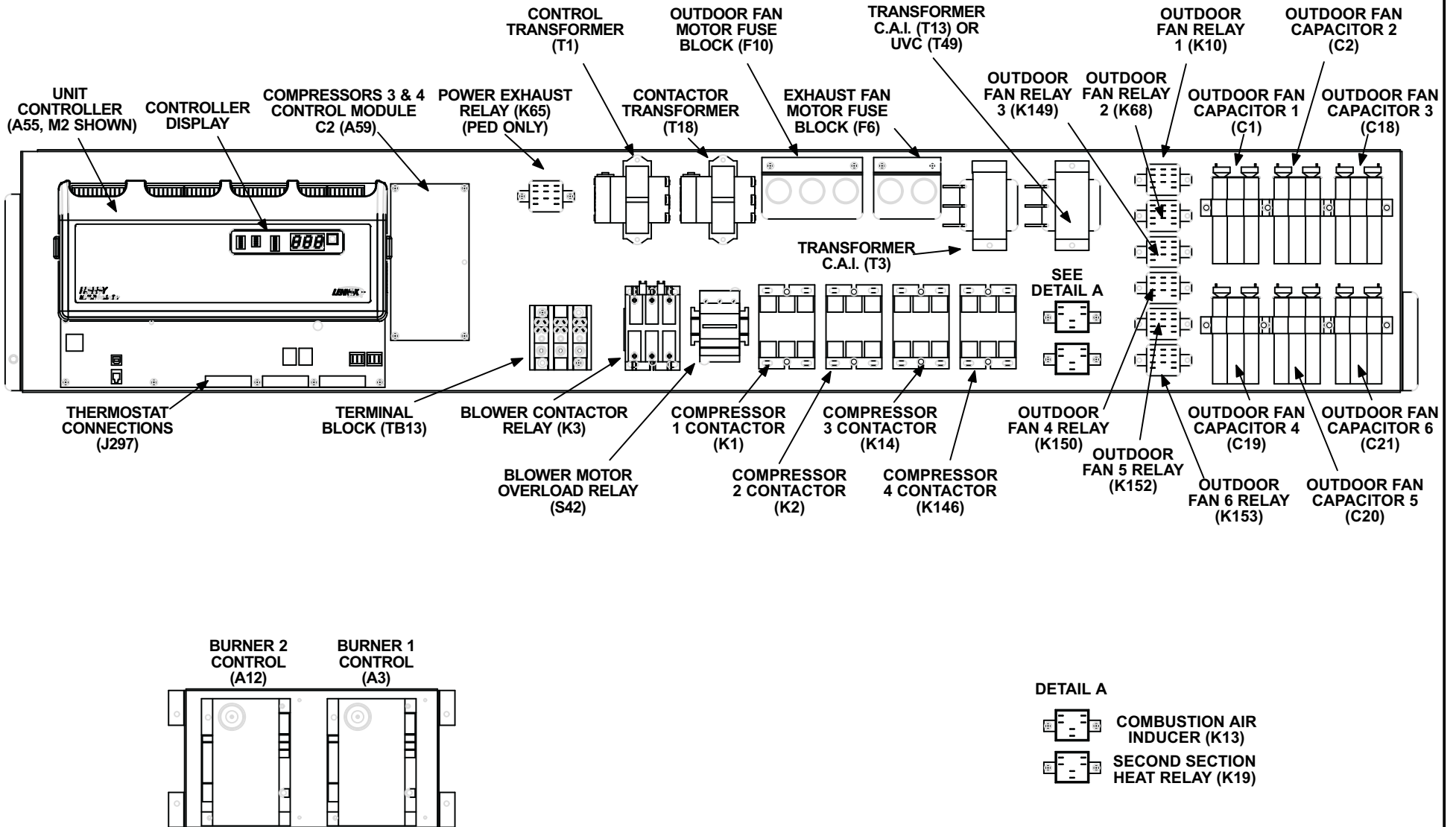

FIGURE 3

CONTROL BOX PARTS ARRANGEMENT (ADD ONS FOR 180U, 240U & 300U)

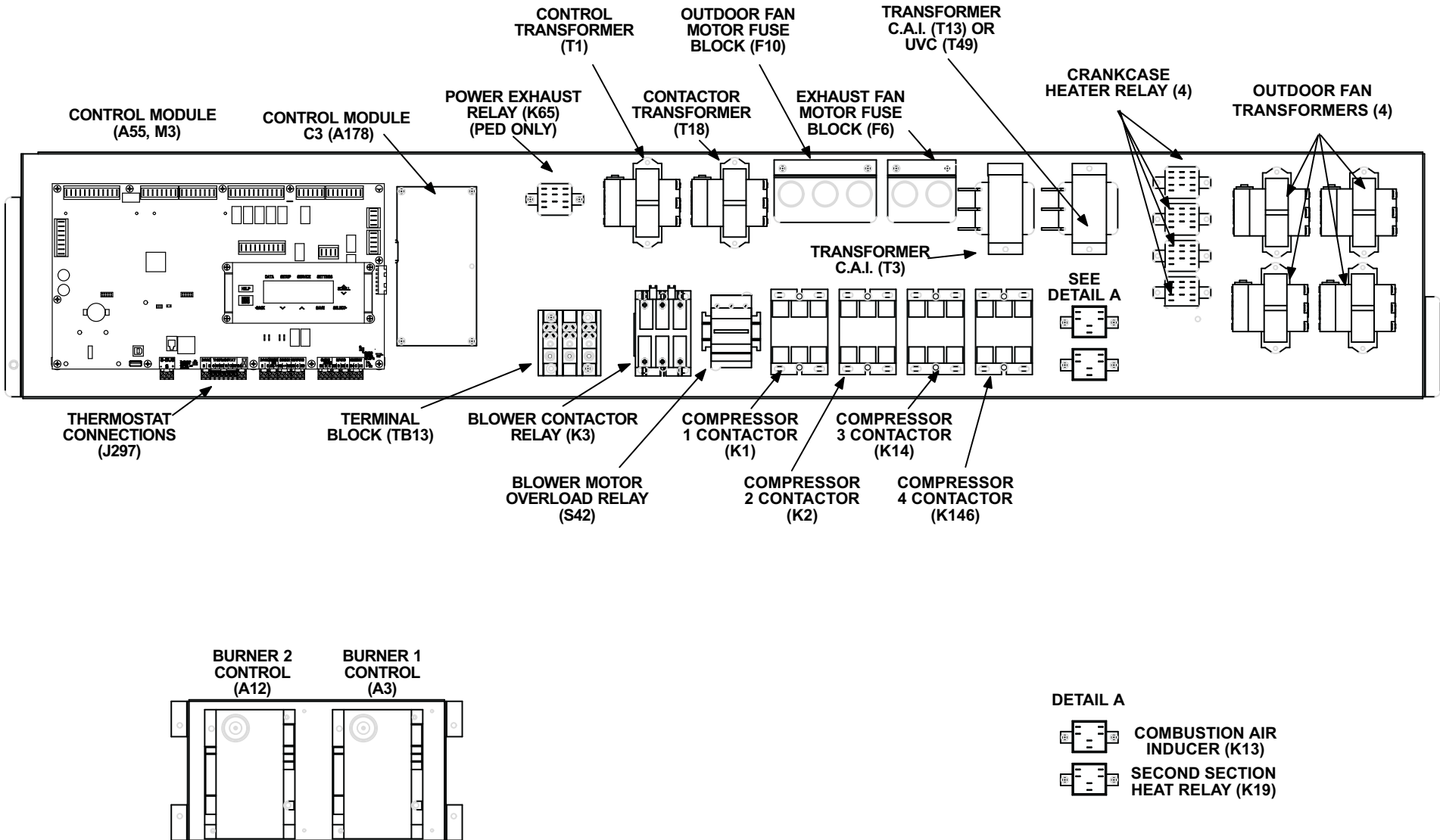

FIGURE 4

4-C. A. I. Transformers T3, T13 (575V units)

All 575 (J) voltage units use transformer T3 and T13. The auto voltage to 230VAC transformers are mounted in the control box. The transformers have an output rating of 0.5A. T3 transformer supplies 230 VAC power to combustion air blower motor (B6), while T13 transformer supplies power to combustion air blower motor (B15) in all units.

T13 also provides 230VAC to optional Ultraviolet Germicidal (UVC) Lamps.

5-Terminal Block TB13

TB13 terminal block distributes line voltage power to the line voltage items in the unit.

6-Outdoor Fan Motor Fuse Block & Fuses F10 Power Exhaust Fan Motor Fuse Block and Fuses F6.

STD SCCR 240V, 300V and higher rated SCCR units have three line voltage fuses F10 provide overcurrent protection to all condenser fans. Two line voltage fuses F6 provide overcurrent protection to the two optional power exhaust fans. The fuses are rated at 30A in all 208/230V units but 10A in the 208/230V 240U and 300U models.

7-Outdoor Fan Capacitors C1, C2, C18, C19, C20, C21 (not used in 180U, 240U, 300U)

C1, C2, & C18:	All units
C19:	180, 210, 240, 300 Units
C20 & C21:	210, 240, 300 Units

Fan capacitors C1, C2, C18, C19, C20 and C21 are 370V / 10 MFD capacitors used to assist in the start up of condenser fans B4, B5, B21, B22, B23 and B24 respectively.

8-Compressor Contactor K1, K2, K14, K146

K1, K2, K14:	All units
K146:	180, 240, 300

All compressor contactors are three-pole-double-break contactors with 24VAC coils. K1 and K2 (energized by A55) energizes compressors B1 and B2 in response to first stage cool demand. K14 and K146 (energized by A59) energize compressors B13 and B20 in response to second stage cool demand. In 180U, 240U, 300U units, K14 and K146 is energized by A178 in response to second stage cool demand.

9-Outdoor Fan Relay K10, K68, K149, K150, K152, K153

K10 & K68:	All units
K149 & K150:	180, 210, 240, 300
K152 & K153:	240, 300

Outdoor fan relays are DPDT relays with a 24VAC coil.

In 156 units, K10 energizes fan 1 B4 and K68 energizes fan 2 B5 and fan 3 B21.

In 180H units, K10 energizes fan 1 B4, K68 energizes fan 2 B5, K149 energizes fan 3 B21 and K150 energizes fan 4 B22.

In 210, 240H and 300 units, K10 energizes fan 1 B4, K68 energizes fan 2 B5, K149 energizes fan 3 B21, K150 energizes fan 4 B22, K152 energizes fan 5 B23 and K153 energizes fan 6 B24.

In 180U, 240U, 300U units, K10 energizes fan 1 B4, K68 energizes fan 2 B5, K149 energizes fan 3 B21, K150 energizes fan 4 B22, K152 energizes fan 5 B23 and K153 energizes fan 6 B24.

10-Blower Contactor K3

Blower contactor K3, used in all units, is a three-pole-double-break contactor with a 24VAC coil used to energize the indoor blower motor B3 in response to blower demand. K3 is energized by Unit Controller (A55). Optional Staged-Blower units which are not equipped with a bypass option will not have a K3.

11-Combustion Air Inducer Relay K13

Combustion air inducer relay K13, used in all units, is a DPDT relay with a 24VAC coil. K13 is energized by the A55 Unit Controller after a first stage heating demand from the thermostat. K13 remains energized throughout the heating demand. When energized, K13 N.O. contacts close to energize combustion air blower and begin a heating sequence. Pressure switch S18, located in the compressor compartment, closes as combustion air static pressure falls to "prove" combustion air inducer operation. When S18 closes, the ignition controls and gas valves are energized to begin a heating sequence.

12-Combustion Air Inducer Relay K19 (second burner section)

Combustion air inducer relay K19 is a DPDT relay with a 24 VAC coil. K19 is energized by A55 Unit Controller after a first stage heating demand from the thermostat. K19 remains energized throughout the first stage heating demand. When energized, K19 N.O. contacts close to energize the second heat section combustion air blower and begin second section heating sequence. Prove switch S45, located in the compressor compartment, closes as combustion air static pressure falls to "prove" combustion air blower operation. When S45 closes, the second section of the ignition control and gas valve are energized to begin the second section heating sequence.

13-Ultraviolet Germicidal Lamp (UVC) Trans- former T49

UVC transformer T49 is used by units of all voltages except 208/230V and 575V which are equipped with a UVC. The auto voltage to 230VAC transformer is installed in the control box. The transformer has an output rating of 0.5 amps. T49 transformer supplies 230VAC power to the UVC lamp.

14-Burner Controls A3 & A12

Units have two burner controls. A3 controls gas heat section one and A12 controls gas heat section two. The first gas heat section and the second gas heat section burner controls are identical. Both burner controls are factory set and are not adjustable. The control makes three attempts at ignition and then locks out the system if ignition is not obtained after the third trial. Reset after lockout requires only breaking and remaking thermostat demand. The control shuts off gas flow immediately in the event of a gas or power failure. Upon restoration of gas and power, the control will restart the ignition sequence and continue until flame is established or system locks out. For a more detailed description see the Gas Heat Components section.

15-Power Exhaust Relay K65 (PED units)

Power exhaust relay K65 is a N.O. DPDT relay with a 24VAC coil. K65 is used in units equipped with the optional power exhaust dampers. K65 is energized by the A55 Unit Controller, after the economizer dampers reach 50% open (adjustable in ECTO). When K65 closes, the exhaust fans B10 and B11 are energized.

16-Blower Motor Overload Relay S42

Two hp high efficiency blower motors and M-volt unit blower motors are equipped with an overload relay. High efficiency blower motors and M-volt unit blower motors manufactured before Dec. 19, 2010, are equipped with the relay.

The relay (S42) is connected in line with the blower motor to monitor the current flow to the motor. When the relay senses an overload condition, a set of normally closed contacts open to de-energize pin #1 in plug P299 of the A55 Unit Controller. A55 de-energizes all outputs. Units will be equipped with a relay manufactured by Telemecanique figure 5 or Siemens figure 6.

17-Variable Frequency Drive A96 (optional)

Staged-Blower units are equipped with a VFD which alters the supply power frequency and voltage to the blower motor. Blower speed is staged depending on the compressor stages, heating demand, ventilation demand, or

smoke alarm. The amount of airflow for each stage is pre-set from the factory. Airflow can be adjusted by changing ECTO parameters in the A55 Unit Controller. The VFD is located below the Unit Controller.

18-VFD Power To Motor Contactor K202 (optional)

Contactor is used in Staged-Blower units equipped with a VFD bypass option. The three-pole 40 amp contactor with a 24VAC coil is energized by the A55 Unit Controller. K202 allows power from the VFD to the B3 blower motor in response to blower demand.

19-Inverter Start Forward Rotation Relay K203 (optional)

Relay is used in optional Staged-Blower units and is a three-pole double-throw relay with a 24VAC coil. K203 is energized by the A55 Unit Controller and provides input to the A96 VFD to start blower forward rotation. K203 also de-energizes K3 allowing A96 to control B3 blower.

20-Unit Controller A55

The Unit Controller provides all unit control functions, unit status information, unit diagnostics, programmable parameters and USB verification and profile sharing. Refer to the Unit Controller guide provided with the unit. Thermostat wires are connected to J297 on the Unit Controller.

21-Compressor 3 & 4 Controller A59 & A178

The compressor 3 & 4 control module A59 controls two additional compressor stages. A59 includes all inputs and outputs required for compressor and fan control, compressor stage diagnostics and low ambient control.

The M3 unit controller is only compatible with L-Connection sensors provided with the unit or purchased separately as specified in the Product Specification. Tables 1 through 4 show thermistor and pressure transducer readings.

Temperature Sensors

The return air (RT16) and discharge air (RT6) duct probes and the outdoor air (RT17) are all two wire thermistors. The resistance vs. temperature table is shown below:

**Table 1
Resistance vs. Temperature**

Temp. °F (°C)	Resistance +/-2%	Temperature °F (°C)	Resistance +/-2%	Temp. °F (°C)	Resistance +/-2%
-40 (-40)	335,671	40 (4.4)	26,106	90 (32.2)	7,332
-20 (-28.9)	164,959	50 (10)	19,904	100 (37.8)	5,826
0 (-17.8)	85,323	60 (15.6)	15,313	120 (48.9)	3,756
20 (-6.7)	46,218	70 (21.1)	11,884	130 (54.4)	3,047
30 (-1.1)	34,566	80 (26.7)	9,298		

Room Sensors

Room sensor (A2) is a two-wire thermistor with 1k series resistor.

**Table 2
Two-Wire Thermistor**

Temp. °F (°C)	Resistance +/-2%	Temperature °F (°C)	Resistance +/-2%	Temp. °F (°C)	Resistance +/-2%
40 (4.4)	27,102	60 (15.6)	16,313	80 (26.7)	10,299
45 (7.2)	23,764	65 (18.3)	14,474	85 (29.4)	9,249
50 (10)	20,898	70 (21.1)	12,882	90 (32.2)	8,529
55 (12.8)	18,433	75 (23.9)	11,498		

Carbon Dioxide Sensor

The indoor carbon dioxide sensor (A63) is an analog sensor with a 0-10VDC output over a carbon dioxide range of 0-2000 ppm as shown in the following table. The sensor is powered with 24VAC.

**Table 3
Carbon Dioxide Range**

Carbon Dioxide PPM	DC V	Carbon Dioxide PPM	DC Voltage	Carbon Dioxide PPM	DC Voltage	Carbon Dioxide PPM	DC V
0	0	600	3	1200	6	1800	9
200	1	800	4	1400	7	2000	10
400	2	1000	5	1600	8		

VAV Supply Static Sensor

The supply duct differential static pressure sensor (A30) is an analog sensor with a 0-10VDC output over a range of 0-5"w.c. as shown in the following table. The sensor is powered with 24VAC.

**Table 4
Static Pressure**

Pressure "w.c.	DC Voltage	Pressure "w.c.	DC Voltage	Pressure "w.c.	DC Voltage	Pressure "w.c.	DC Voltage
0	0	1.5	3	3	6	4.5	9
0.5	1	2	4	3.5	7	5	10
1	2	2.5	5	4	8		

Relative Humidity Sensor - Optional

The indoor relative humidity sensor (A91) is an analog sensor with a 0-10VDC output over a relative humidity range of 0-100% relative humidity. The sensor is powered with 24VAC.

Enthalpy Sensor - Optional

The optional enthalpy sensors (A7 and A63) used with the economizer have an output of 4-20mA. The sensor is powered with 18VAC provided by M3 unit control.

Economizer Differential Pressure Sensor - Optional

Rooftop units installed with Smart Airflow™ will have a Pressure Transducer (PT5) present in the economizer. PT5 requires 5VDC power supply (P266-5 and {P266-6) and gives 0.25 VDC to 4 VDC output (P266-4) corresponding to 0" water column and 2" water column respectively. For all practical purposes the output should be less than 1.2" water column if not an error code is stored and service alarm output is turned on.

22-VFD Controller (GP board) A133 (Staged-Blower units)

The GP board A133 controls and monitors the status of the VFD A96. The board sends the signal to start the VFD forward rotation and also sends a 0-10VDC signal to the VFD to control the speed of the blower rotation. A133 also reports VFD malfunctions to the A55.

23-Second-Stage Power Exhaust Relay K231 (Staged-Blower units equipped with power exhaust)

The second power exhaust fan is controlled by K231. A133 will enable K231 only when the blower reaches 70% of full speed (adjustable ECTO). This prevents a negative building pressure when the blower is operating in low

speed. Refer to the Unit Controller manual and ECTO labels on the unit.

24-Outdoor Fan Transformers T5, T59 (460V & 575V units)

All 460 (G) and 575 (J) voltage 180U, 240U and 300U units use transformer T5 and T59. The auto voltage to 230VAC transformers are mounted in the control box. The transformers have an output rating of 0.5A. T5 transformer supplies 230 VAC power to outdoor fans B4, B5 and B21. T13 transformer supplies 230V to outdoor fans B22, B23 and B24.

25-Fuse F61 (Higher SCCR units only)

Fuse F61 is used on units with higher SCCR rating. F61 provides overcurrent protection to compressor and other cooling components. F61 and S48 are located inside a sheet metal enclosure in the unit left front corner mullion.

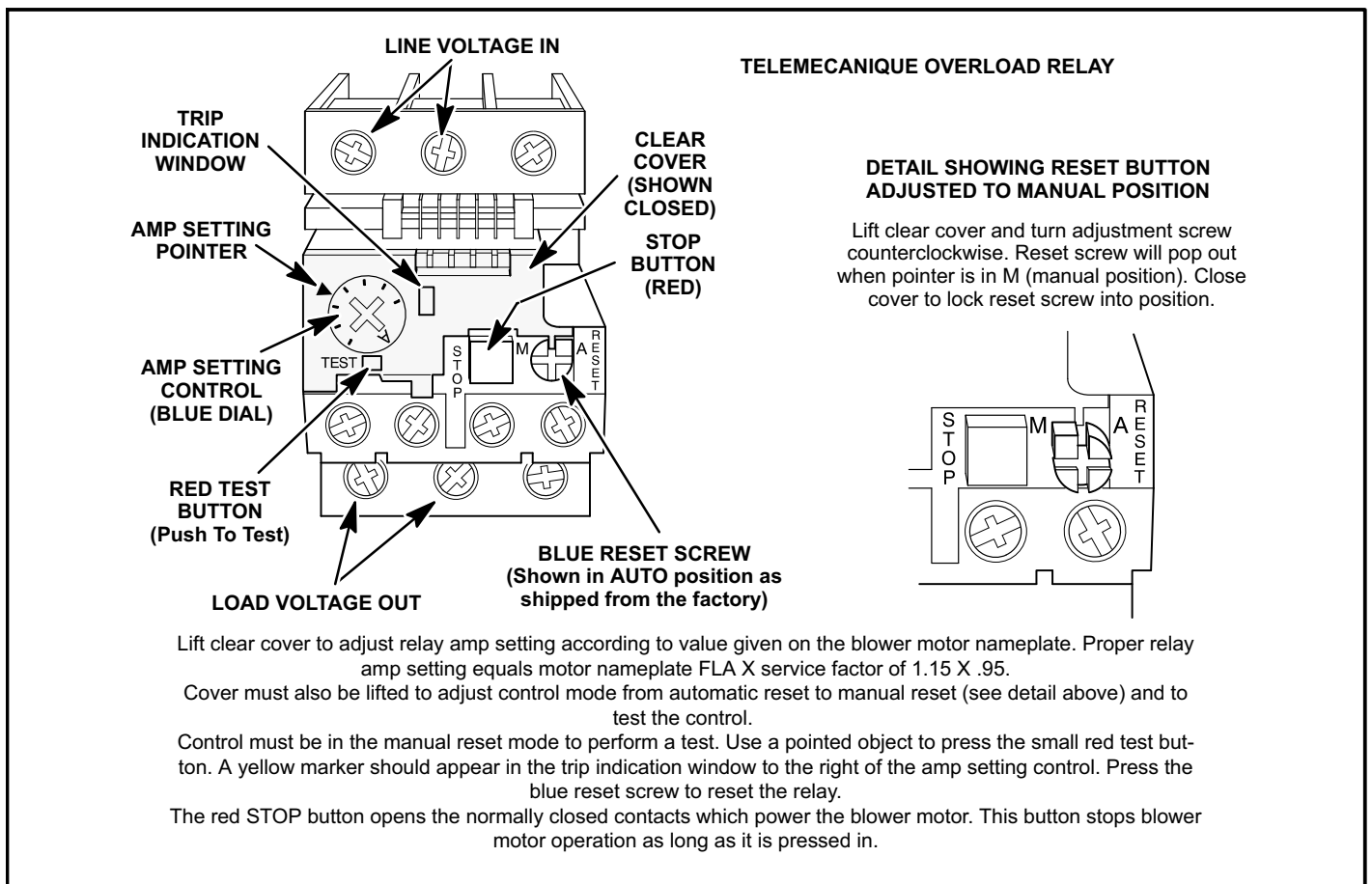
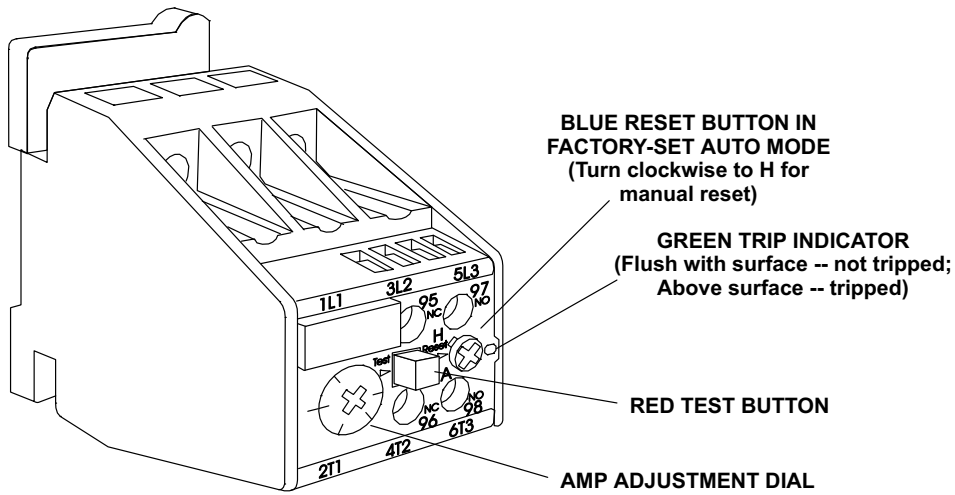

FIGURE 5

SIEMENS OVERLOAD RELAY



Adjust relay amp setting according to value given on the blower motor nameplate. Proper relay amp setting equals motor nameplate FLA X service factor of 1.15 X .95.

Use small slotted screwdriver to adjust control mode from automatic reset (A) to manual reset (H). Control must be in the manual reset mode (H) to perform a test. Press the red test button. Green trip indicator should pop out. Press the blue reset screw to reset the relay.

FIGURE 6

156H, 180H, 210H PLUMBING, COMPRESSOR AND REFRIGERANT CIRCUITS DETAIL

156 VAV, 180 VAV ONLY
EVAPORATOR COIL
(not to scale)

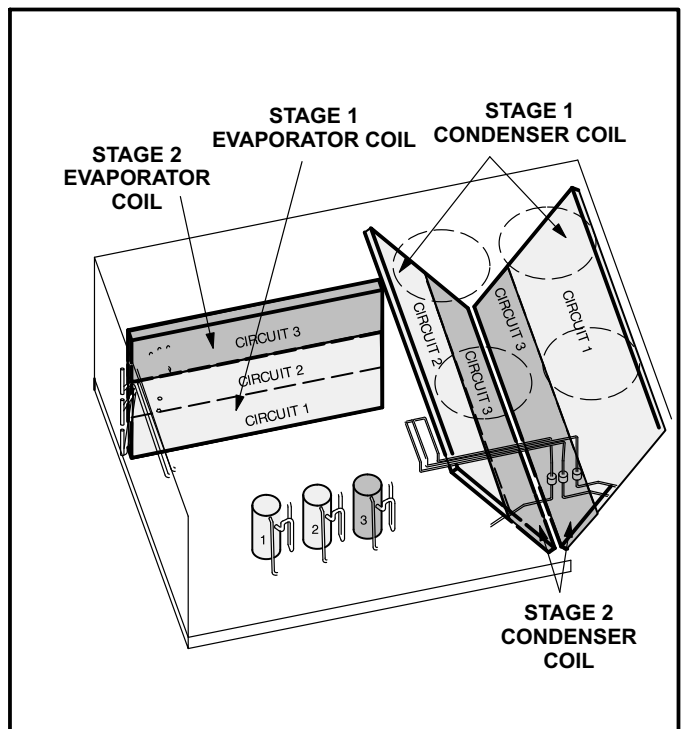
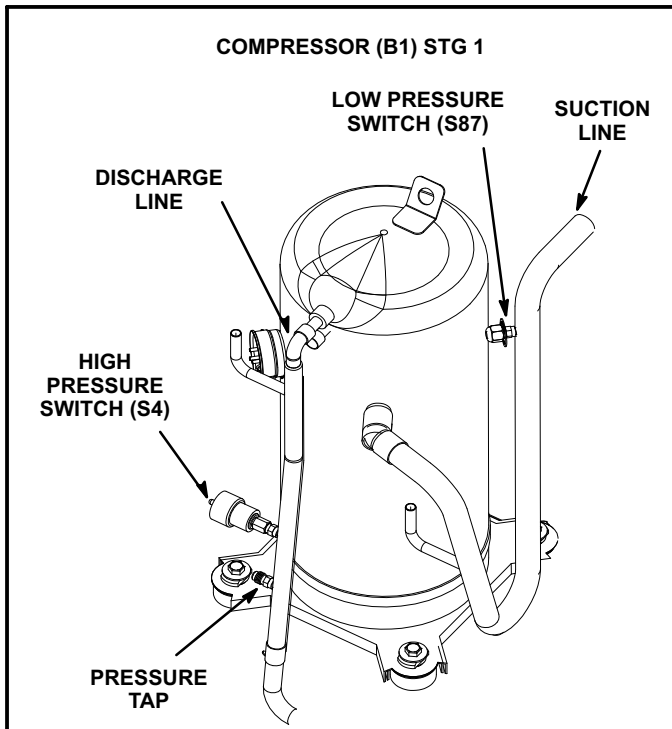
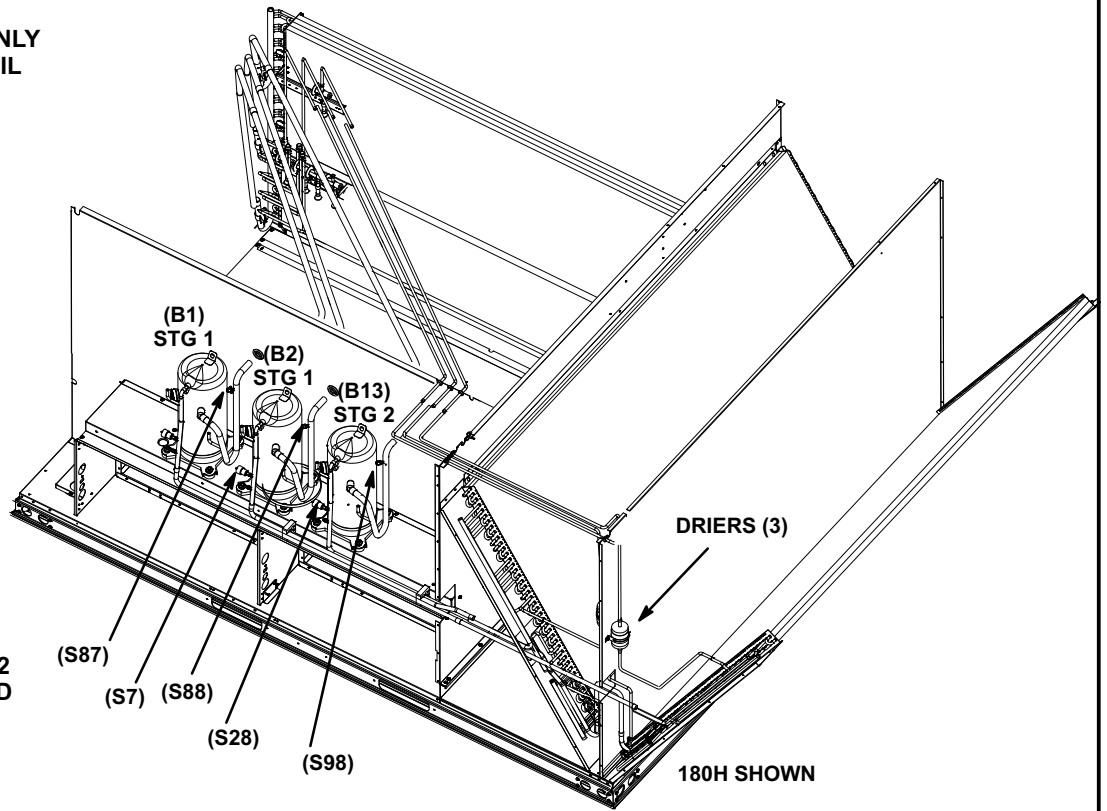
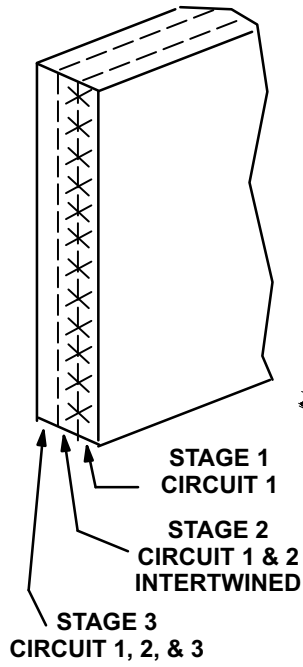

FIGURE 7

240H, 300S, 300U PLUMBING, COMPRESSOR AND REFRIGERANT CIRCUITS DETAIL

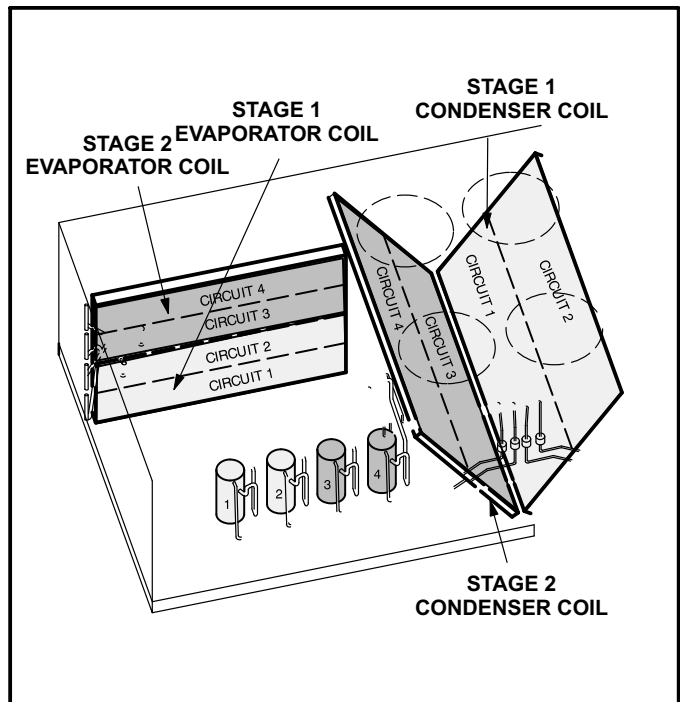
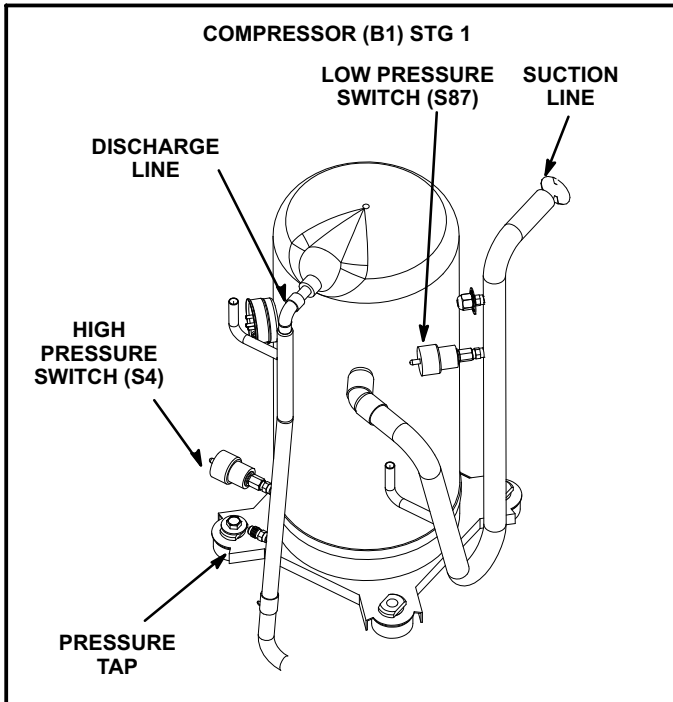
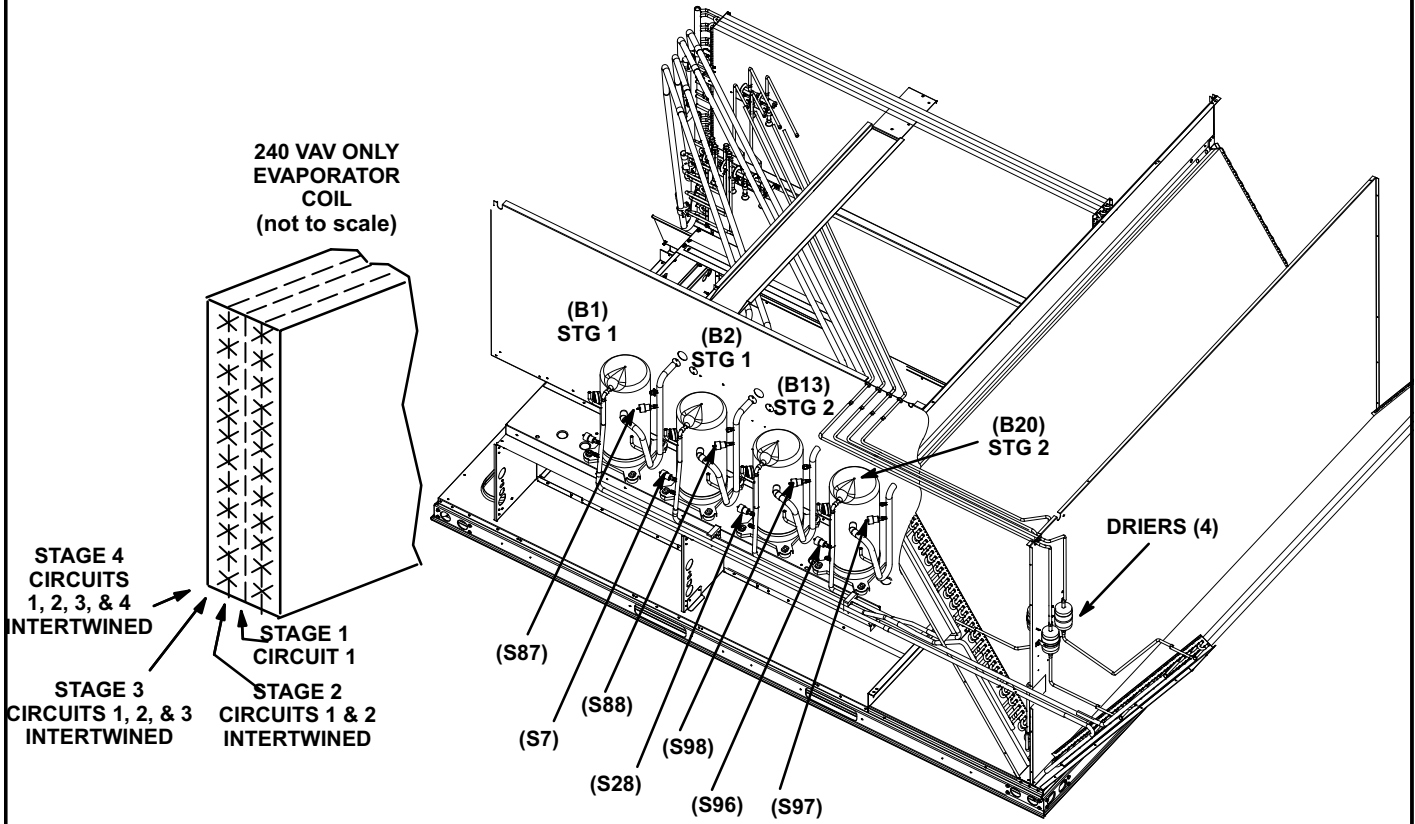
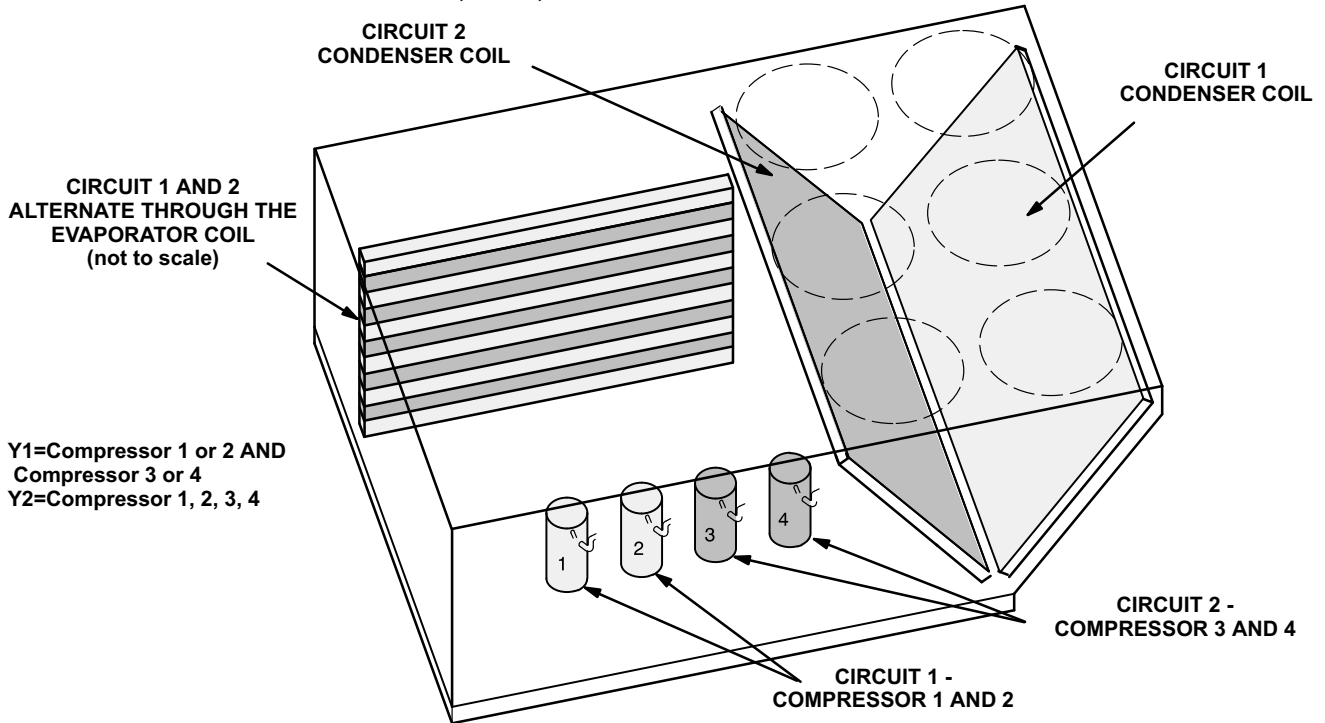

FIGURE 8

180U, 240U, 300U REFRIGERANT CIRCUITS



180U, 240U, 300U COMPRESSOR DETAIL

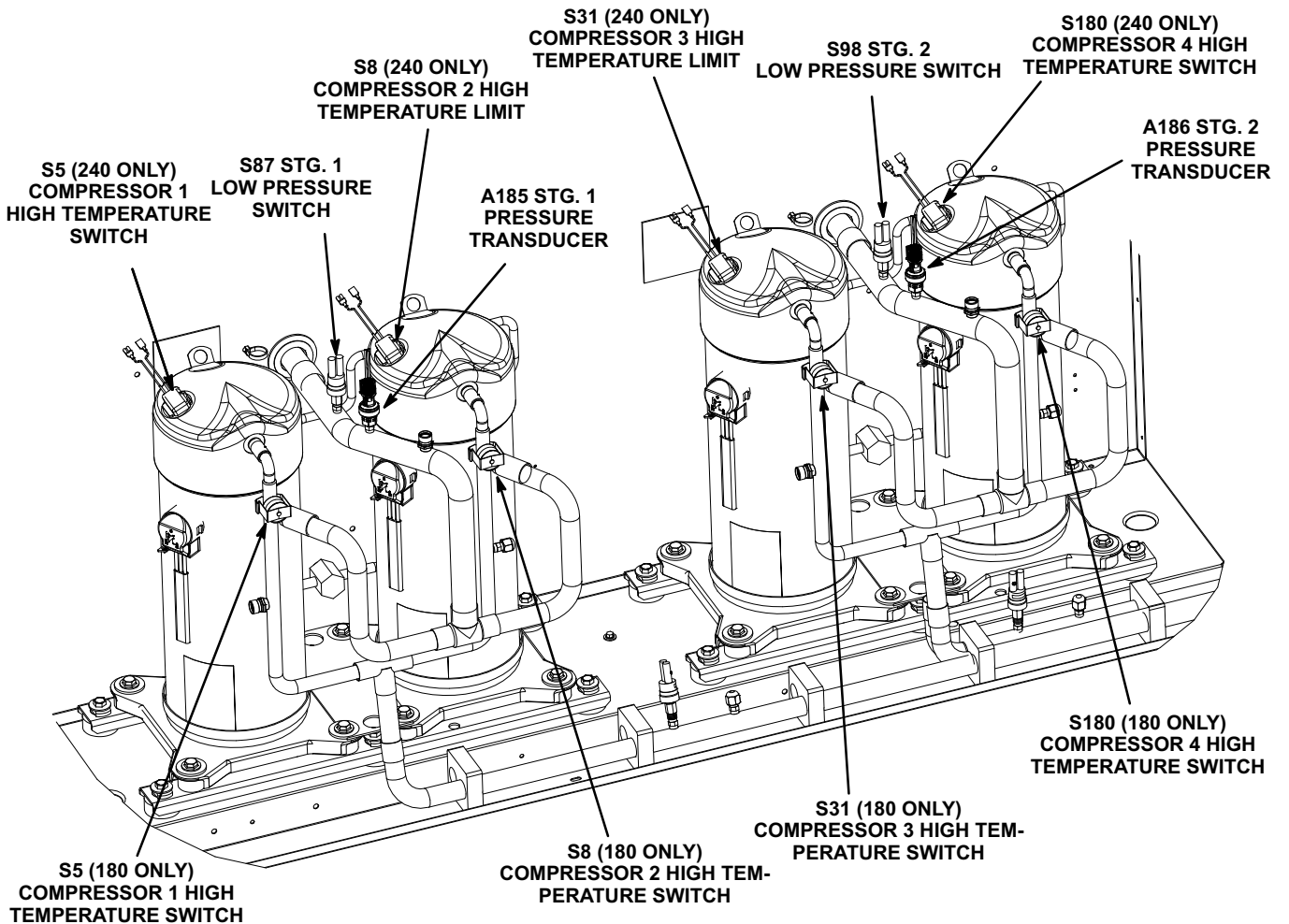

FIGURE 9

B-Cooling Components

All standard and high efficiency units use independent cooling circuits consisting of separate compressors, condenser coils and evaporator coils. See figure 7 for 156, 180 and 210 units and figure 8 for 240 and 300 units. Ultra high efficiency units use independent cooling circuits consisting of two compressors, one condenser coil, and one evaporator coil per circuit. See figure 9 for 180U, 240U and 300U unit details.

Three draw-through type condenser fans are used in LGH156 units, four draw-through type condenser fans are used in LGH180H units and six draw-through type condenser fans are used in LGH180U, LGH210, 240 and 300 units. All units are equipped with belt-drive blowers which draw air across the evaporator during unit operation.

Cooling may be supplemented by a factory- or field-installed economizer. The evaporators used for standard and high efficiency units are slab type and are stacked. Ultra units use an intertwined evaporator. Each evaporator uses a thermostatic expansion valve as the primary expansion device. Each evaporator is also equipped with enhanced fins and rifled tubing. In all units each compressor is protected by a crankcase heater, high pressure switch and low pressure switch. Additional protection is provided by low ambient switches and freezestats (on each evaporator).

1-Compressors B1, B2, B13 (all units) B20 (180U, 240, 300)

All units use scroll compressors. LGH156, 180H and 210 use 3 compressors and LGH180U, 240 and 300 use four compressors. On standard and high efficiency units all compressors are equipped with independent cooling circuits. On ultra high efficiency units two compressors share a common cooling circuit. Compressor capacity may vary from stage to stage. In all cases, the capacity of each compressor is added to reach the total capacity of the unit. See "SPECIFICATIONS" and "ELECTRICAL DATA" (table of contents) or compressor nameplate for compressor specifications.

WARNING

Electrical shock hazard. Compressor must be grounded. Do not operate without protective cover over terminals. Disconnect power before removing protective cover. Discharge capacitors before servicing unit. Failure to follow these precautions could cause electrical shock resulting in injury or death.

Each compressor is energized by a corresponding compressor contactor.

NOTE-Refer to the wiring diagram section for specific unit operation.

If Interlink compressor replacement is necessary, call 1-800-4-LENNOX (1-800-453-6669).

IMPORTANT

Some scroll compressors have an internal vacuum protector that will unload scrolls when suction pressure goes below 20 psig. A hissing sound will be heard when the compressor is running unloaded. Protector will reset when low pressure in system rises above 40 psig. DO NOT REPLACE COMPRESSOR.

2-Crankcase Heaters HR1, HR2, HR5 (all units) HR11 (180U, 240, 300)

All LGH units use insertion type heaters. Heater HR1 is installed around compressor B1, heater HR2 compressor B2, HR5 compressor B13 and HR11 compressor B20.

3-High Pressure Switches S4, S7, S28, S96

S4 all units

S7 all standard and high efficiency units only

S28 all units

S96 240H and 300

The high pressure switches is an auto-reset SPST N.C. switch which opens on a pressure rise. All units are equipped with this switch. The switch is located in the compressor discharge line and is wired in series with the compressor contactor coil through A55 unit controller or A178 compressor 3 and 4 controller (earlier units will have A59 compressor 3 and 4 controller).

For standard and high efficiency units S4 (first circuit), S7 (second circuit), S28 (third circuit) and S96 (fourth circuit) are wired in series with the respective compressor contactor coils. In the ultra high efficiency units, S4 is wired in series with B1 and B2 compressor contactors and S28 is wired in series with B13 and B20 compressor contactors. When discharge pressure rises to 640 ± 10 psig (4413 ± 69 kPa) (indicating a problem in the system) the switch opens and the respective compressor(s) is de-energized (the economizer can continue to operate). When discharge pressure drops to 475 ± 20 psig (3275 ± 138 kPa) the pressure switch will close re-energizing the compressor(s).

Main control A55 has a three-strike counter before locking out. This means the control allows three high pressure trips per one thermostat demand. The control can be reset by breaking and remaking the thermostat demand or manually resetting the control.

4-Low Ambient Switches S11, S84, S85 (all units) S94 (240, 300)

S11 all units

S84 all standard and high efficiency units only

S85 all units

S94 240H and 300

The low ambient switch is an auto-reset SPST N.O. pressure switch which allows for mechanical cooling operation at low outdoor temperatures. All units are equipped with this switch. In all models a switch is located in each liquid line prior to the indoor coil section.

In LGH180H/210 units, S11 (compressor one) is wired to the Unit Controller (A55) and S84 (compressor two) and S85 (compressor three) are wired in parallel to the Unit Controller. In LGH240H/300 units, S11 (compressor one) and S84 (compressor 2) are wired in parallel to the Unit Controller; S85 (compressor 3) and S94 (compressor four) are wired in parallel to the Unit Controller. In 180U, 240U and 300U models, S11 (compressor 1 and 2) and S85 (compressor 3 and 4) are wired to unit controller A55.

When liquid pressure drops to 240 ± 10 psig (1655 ± 69 kPa), the switch opens and the Unit Controller will cycle condenser fans via the following outdoor fan relays:

K10 and K68 (156H, 180H, 210H, 300)
K149 and K150 (180H, 210, 240H, 300 units)
K152 and K153 (180U, 210, 240, 300 units)

When liquid pressure rises to 450 ± 10 psig (3102 ± 69 kPa), the switch closes and re-energizes the condenser fans.

The Unit Controller cycles fans based on the low ambient pressure switch inputs and outdoor ambient temperature.

This intermittent fan operation results in higher evaporating temperature allowing the system to operate without icing the evaporator coil and losing capacity.

5-Low Pressure Switches S87, S88, S97, S98

S87 all units
S88 all standard and high efficiency units only
S97 240H, 300
S98 all units

The low pressure switch is an auto-reset SPST N.O. switch (held N.C. by refrigerant pressure) which opens on a pressure drop. All units are equipped with this switch. The switch is located in the compressor suction line.

On standard and high efficiency units, S87 (compressor one), S88 (compressor two), S98 (compressor three) and S97 (compressor four) are wired in series with the contactor coils through the A55 Unit Controller. On ultra high efficiency units S87 (compressor one and two) and S98 (compressor three and four) are wired in series with the contactor coils through the A55 Unit Controller

The Unit Controller A55 governs the low pressure switches by shunting the switches during start up until pressure is stabilized. After the shunt period, the control has a three-strike counter, during a single thermostat demand, before the compressor(s) is locked out. The control is reset by breaking and remaking the thermostat demand or manually resetting the control.

When suction pressure drops to 40 ± 5 psig (276 ± 34 kPa), (indicating low pressure), the switch opens and the compressor(s) is de-energized. The switch automatically resets when pressure in the suction line rises to 90 ± 5 psig (620 ± 34 kPa).

6-Service Valve (optional)

Units may be equipped with service valves located in the discharge and liquid lines. The service valves are manually operated valves used for service operation.

7-Filter Drier (all units)

Units have a filter drier located in the liquid line of each refrigerant circuit at the exit of each condenser coil. The drier removes contaminants and moisture from the system.

8-Freezestats S49, S50, S53 (all units) and S95 (240, 300)

S49 all units
S50 all standard and high efficiency units only
S53 180U, 240U, 300U
S95 240H, 300

Each unit is equipped with a low temperature switch (freezestat) located on the return bend of each evaporator coil. S49 (first circuit), S50 (second circuit), S53 (third circuit) and S95 (fourth circuit) are located on the corresponding evaporator coils.

Each freezestat is wired in series with the compressor contactor coil(s) through the unit control box to the A55 Unit Controller. Each freezestat is a SPST N.C. auto-reset switch which opens at $29^{\circ}\text{F} \pm 3^{\circ}\text{F}$ ($-1.7^{\circ}\text{C} \pm 1.7^{\circ}\text{C}$) on a temperature drop and closes at $58^{\circ}\text{F} \pm 4^{\circ}\text{F}$ ($14.4^{\circ}\text{C} \pm 2.2^{\circ}\text{C}$) on a temperature rise. To prevent coil icing, freezestats open during compressor operation to temporarily disable the respective compressor(s) until the coil warms sufficiently to melt any accumulated frost.

If the freezestats are tripping frequently due to coil icing, check the unit charge, airflow and filters before allowing unit back in operation. Make sure to eliminate conditions which might promote evaporator ice buildup.

9-Condenser Fans B4, B5, B21 (all units), B22 (180-300), B23, B24 (180U, 210-300S, 300U)

See SPECIFICATIONS tables at the front of this manual for specifications of condenser fans used in all units. All condenser fans used have single-phase motors. The fan assembly may be removed for servicing and cleaning.

10-Pressure Transducer A185 &A186 (180U, 240U & 300U)

Ultra high efficiency units are equipped with a pressure transducer located on the common suction line. The Unit Controller uses the input from the transducer A185, sensors RT37 and RT38 (stage one) and transducer A186 sensor RT39 and RT40 (second stage) to calculate sump superheat for each compressor. The Unit Controller uses this information to optimize system reliability.

Verify the sensor value using the menu path:

MAIN MENU > DATA > IN/OUTPUTS > SENSORS > LOCAL
A185 and A186 should read within +/- 10 psi of actual suction pressure.

11-High Temperature Limit Switch S5, S8, S31 & S180 (180U, 240U & 300U)

These high temperature limit switches are N.C and wired in series with the compressor contactors. When opened due to high temperature the compressor contactors are de-energized, de-energizing the compressors. S5 and S8 are in series with contactors K1 and K2 and compressors B1 and B2. S31 and S180 are in series with contactors K14 and K146 and compressors B13 and B20. See unit diagram.

C-Blower Compartment

The blower compartment is located between the evaporator coil and the compressor / control section on the opposite side of the condenser coil. The blower assembly is accessed by disconnecting the blower motor wiring (and all other plugs) and removing the screws on either side of the sliding base. The base pulls out as shown in figure 10.

1-Blower Wheels

All units have two 15 in. x 15 in. (381 mm x 381 mm) blower wheels. Both wheels are driven by one motor.

2-Indoor Blower Motor B3

All units use three-phase single-speed blower motors. CFM adjustments are made by adjusting the motor pulley (sheave). Motors are equipped with sealed ball bearings. All motor specifications are listed in the SPECIFICATIONS (table of contents) in the front of this manual. Units may be equipped with motors manufactured by various manufacturers, therefore electrical FLA and LRA specifications will vary. See unit rating plate for information specific to your unit.

OPERATION / ADJUSTMENT

Staged-Blower Units - The blower rotation will always be correct on staged-blower units. Checking blower rotation is not a valid method of determining voltage phasing for incoming power.

Staged-Blower Units and Units Equipped With Optional Voltage or Phase Detection - The Unit Controller checks the incoming power during start-up. If the voltage or phase is incorrect, the Unit Controller will display an alarm and the unit will not start.

Variable Air Volume Units - Refer to the Variable Air Volume Start-Up section.

1. The following measurements must be made with a dry indoor coil. Run blower (G demand) without a cooling demand. Measure the indoor blower shaft RPM. Air filters must be in place when measurements are taken.

2. With all access panels in place, measure static pressure external to unit (from supply to return). Blower performance data is based on static pressure readings taken in locations shown in figure 11.

Note - Static pressure readings can vary if not taken where shown.

3. Referring to page 17, use static pressure and RPM readings to determine unit CFM. Use page 18 when installing units with any of the optional accessories listed.
4. The blower RPM can be adjusted at the motor pulley. Loosen Allen screw and turn adjustable pulley clockwise to increase CFM. Turn counterclockwise to decrease CFM. See figure 10. Do not exceed minimum and maximum number of pulley turns as shown in table 5.

**TABLE 5
MINIMUM AND MAXIMUM PULLEY ADJUSTMENT**

Belt	Minimum Turns Open	Maximum Turns Open
A Section	No minimum	5
B Section	1*	6

*No minimum number of turns open when B belt is used on pulleys 6" O.D. or larger.

⚠ IMPORTANT

Three Phase Scroll Compressor Voltage Phasing

Three phase scroll compressors must be phased sequentially to ensure correct compressor and blower* rotation and operation. Compressor and blower are wired in phase at the factory. Power wires are color-coded as follows: line 1-red, line 2-yellow, line 3-blue.

1-Observe suction and discharge pressures and blower* rotation on unit start-up.

2-Suction pressure must drop, discharge pressure must rise and blower* rotation must match rotation marking.

If pressure differential is not observed or blower* rotation is not correct:

3-Disconnect all remote electrical power supplies.

4-Reverse any two field-installed wires connected to the line side of S48 disconnect or TB13 terminal strip. Do not reverse wires at blower contactor.

5-Make sure the connections are tight.

Discharge and suction pressures should operate at their normal start-up ranges.

***Supply air VFD motors should rotate in the correct direction; verify scroll compressor rotation separately. Contact technical support if the VFD blower is rotating incorrectly.**

Blower Operation

NOTE-The following is a generalized procedure and does not apply to all thermostat control systems.

- 1- Blower operation is dependent on the thermostat control system option that has been installed in the units. Refer to operation sequence of the control system installed for detailed descriptions of blower operation.
- 2- Generally, blower operation is set at the thermostat fan switch. With the fan switch in "ON" position and the **OCP** input is "ON", the blower operates continuously. With the fan switch in "AUTO" position, the blower cycles with demand.
- 3- In most cases, the blower and entire unit will be off when the system switch is in the "OFF" position. The only exception is immediately after a heating demand when the blower control keeps the blower on until all heat is extracted from the heat exchanger.

Determining Unit Air Volume

IMPORTANT - Staged-Blower units are factory-set to run the blower at full speed when there is a blower (G) demand without a heating or cooling demand. Refer to the field-provided, design specified CFM for all modes of operation. Use the following procedure to adjust motor pulley to deliver the highest CFM called for in the design spec. See Staged-Blower Start-Up section to set blower CFM for all modes once the motor pulley is set.

On VAV units duct static feedback will control indoor blower CFM for beltdrive with a VFD.

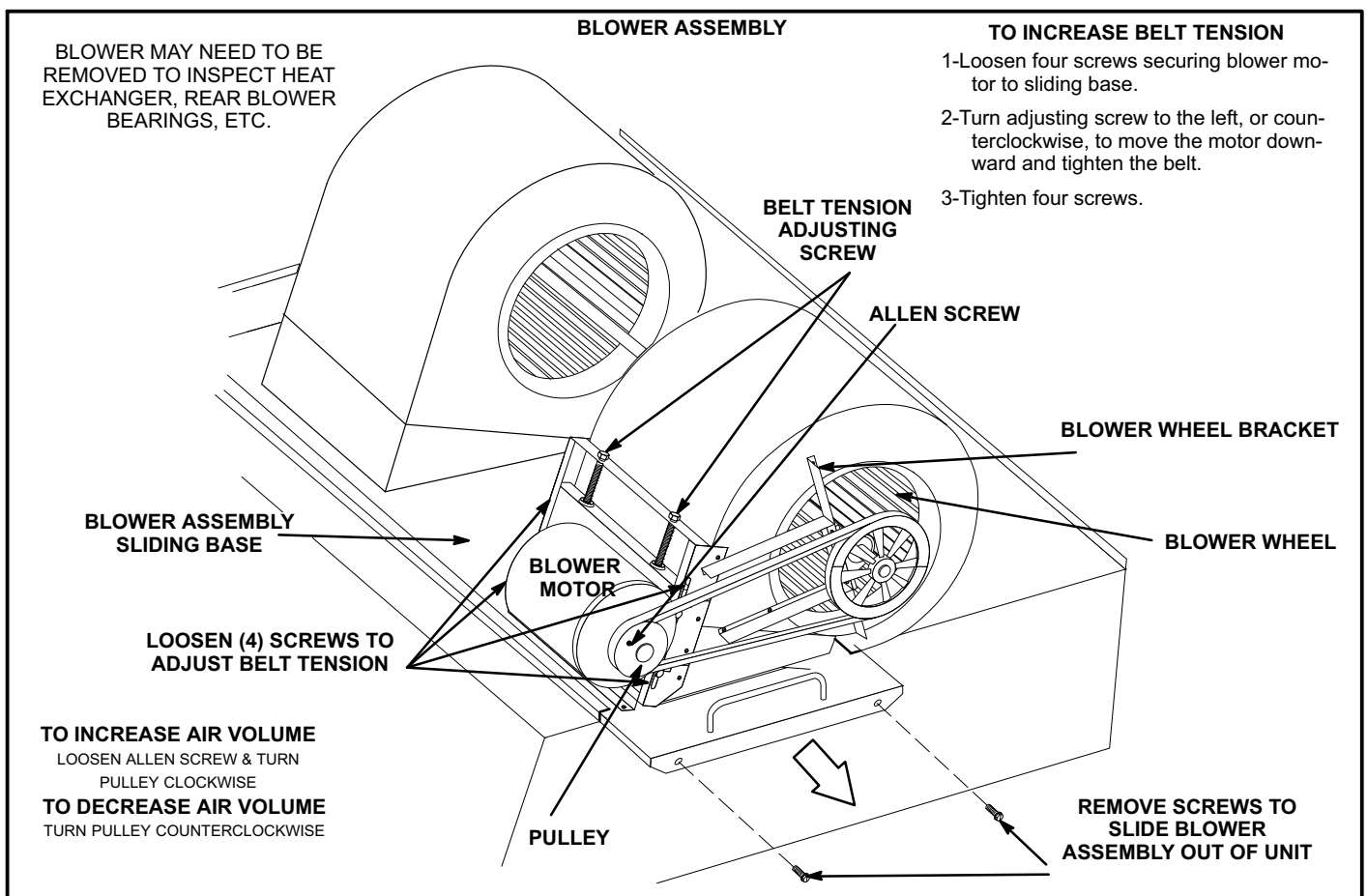

FIGURE 10

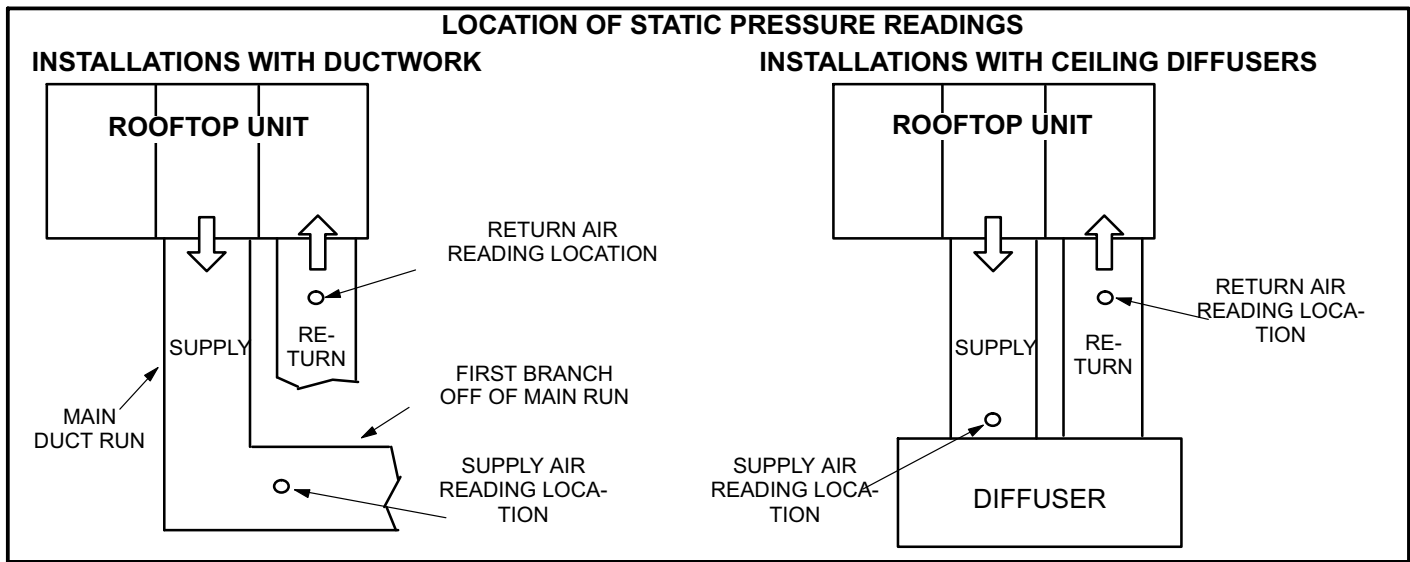

FIGURE 11

- 1- The following measurements must be made with a dry indoor coil. Run blower without cooling demand. Air filters must be in place when measurements are taken.
- 2- With all access panels in place, measure static pressure external to unit (from supply to return). Blower performance data is based on static pressure readings taken in locations shown in figure 11.

Note - Static pressure readings can vary if not taken where shown.

- 3- Measure the indoor blower wheel RPM.
- 4- Refer to blower tables in BLOWER DATA (table of contents) in the front of this manual. Use static pressure and RPM readings to determine unit air volume.
- 5- The RPM can be adjusted at the motor pulley. Loosen Allen screw and turn adjustable pulley clockwise to increase RPM. Turn counterclockwise to decrease RPM. See figure 10.

Blower Belt Adjustment

Maximum life and wear can be obtained from belts only if proper pulley alignment and belt tension are maintained. Tension new belts after a 24-48 hour period of operation. This will allow belt to stretch and seat into pulley grooves. Make sure blower and motor pulley are aligned as shown in figure 12 for standard blowers and figure 13 for units equipped with an optional belt tensioner.

Standard Blowers

1. Loosen four screws securing blower motor to sliding base. See figure 10.
2. *To increase belt tension -*
Turn belt tension adjusting screw to the left, or counterclockwise, to tighten the belt. This increases the distance between the blower motor and the blower housing.

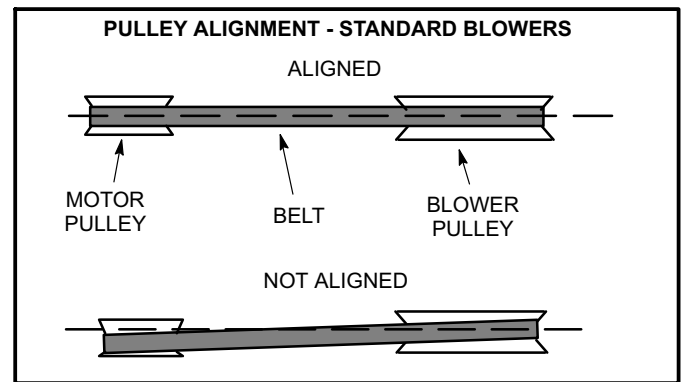

FIGURE 12

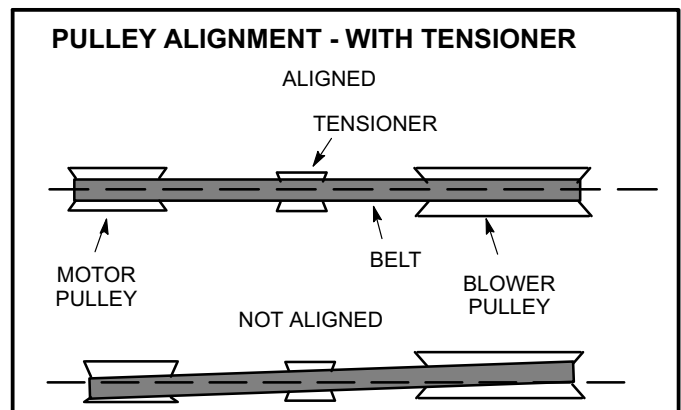

FIGURE 13

To loosen belt tension -

Turn the adjusting screw to the right, or clockwise to loosen belt tension.

3. Tighten four screws securing blower motor to sliding base once adjustments have been made.

Blowers Equipped With Belt Tensioner

1. Loosen the bolt in the center of the tensioner. See figure 14.
2. Place belt over all three pulleys.
3. Using a 15/16" wrench, turn the tensioner nut until marks align as shown in figure 14.
4. Hold the tensioner with marks aligned and tighten the bolt to 22 ft.lbs. using the 9/16" wrench.

PULLEY ALIGNMENT - WITH TENSIONER

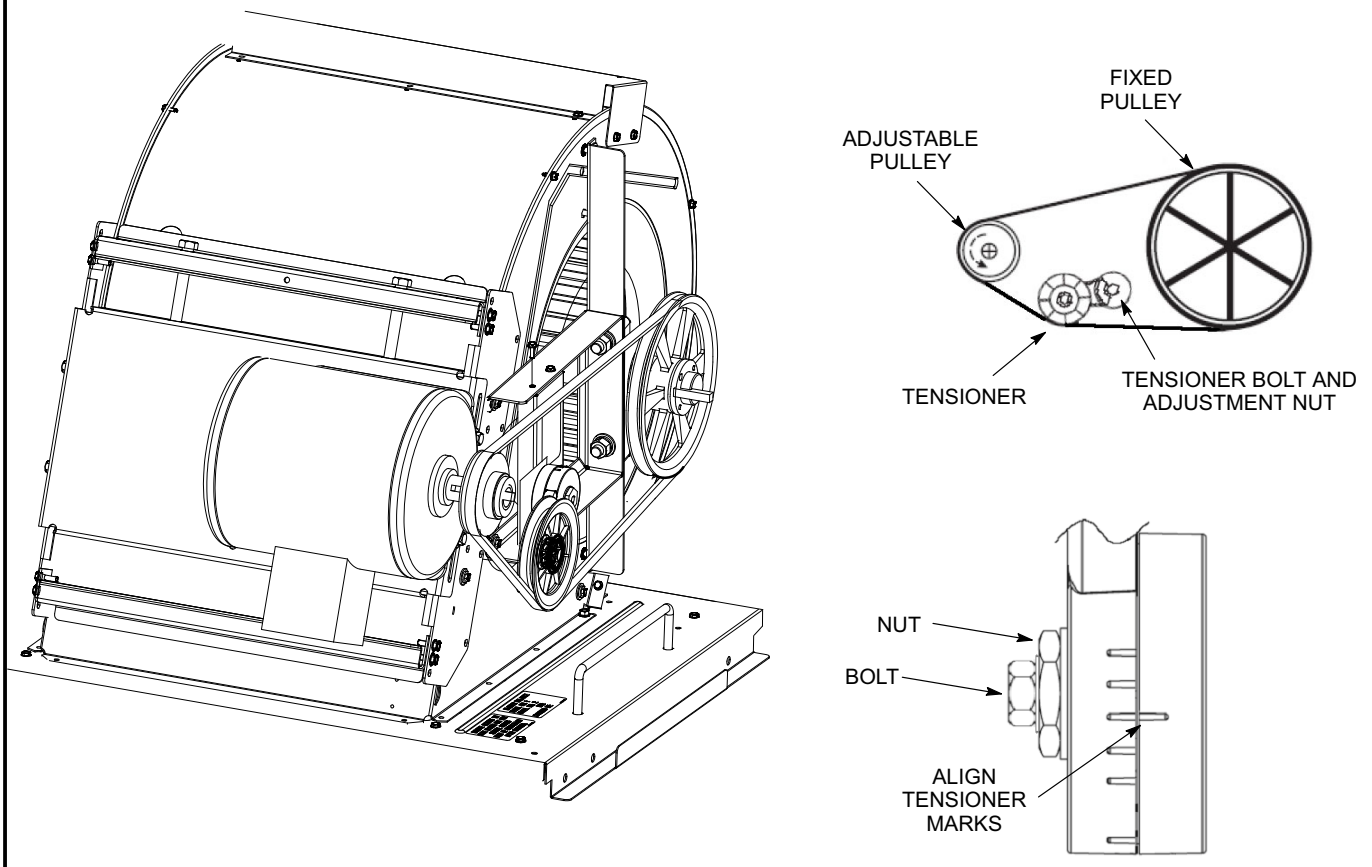

FIGURE 14

Check Belt Tension

Overtensioning belts shortens belt and bearing life. Check belt tension as follows:

1. Measure span length X. See figure 15.
2. Apply perpendicular force to center of span (X) with enough pressure to deflect belt $1/64$ " for every inch of span length or 1.5mm per 100mm of span length.

Example: Deflection distance of a 40" span would be $40/64$ " or $5/8$ ".

Example: Deflection distance of a 400mm span would be 6mm.

3. Measure belt deflection force. For a used belt, the deflection force should be 5 lbs. (35kPa) . A new belt deflection force should be 7 lbs. (48kPa).

A force below these values indicates and undertensioned belt. A force above these values indicates an overtensioned belt.

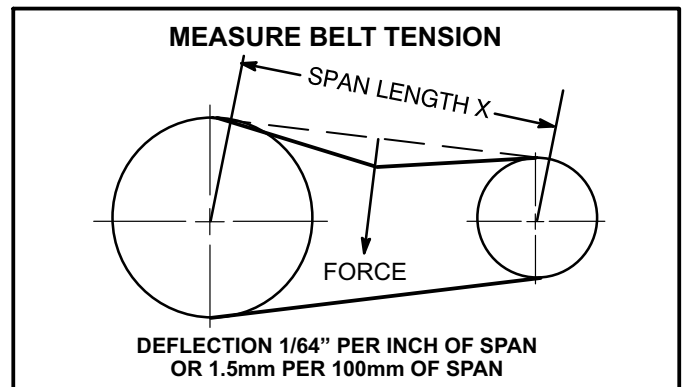

FIGURE 15

Field-Furnished Blower Drives

For field-furnished blower drives, Refer to blower tables in BLOWER DATA section to determine BHP and RPM required. Reference table 6 and 7 to determine the manufacturer's model number.

TABLE 6

Drive No.	H.P.	DRIVE COMPONENTS					
		RPM		ADJUSTABLE SHEAVE		FIXED SHEAVE	
		Min	Max	Supplier No.	OEM Part No.	Supplier No.	OEM Part No.
1	2 & 3 Std.	535	725	1VP40x7/8	79J0301	BK95 x 1-7/16	80K1601
2	2 & 3 Std.	710	965	1VP40x7/8	79J0301	BK72 x 1-7/16	100244-13
3	3 High & 5	685	865	1VP50x1-1/8	P-8-1977	BK100 x 1-7/16	39L1301
4	3 High & 5	850	1045	1VP65x1-1/8	100239-03	BK110H	100788-06
5	5	945	1185	1VP60x1-1/8	41C1301	BK90H x 1-7/16	100788-04
6	7.5	850	1045	1VP65x1-3/8	78M7101	BK110H	100788-06
7	7.5 & 10	945	1185	1VP60x1-3/8	78L5501	BK90H x 1-7/16	100788-04
8	7.5	1045	1285	1VP65x1-3/8	78M7101	BK90H x 1-7/16	100788-04
10	10	1045	1285	1VP65x1-3/8	78M7101	1B5V86	78M8301
11	10	1135	1365	1VP65x1-3/8	78M7101	1B5V80	100240-05

TABLE 7

Drive No.	H.P.	DRIVE COMPONENTS							
		RPM		BELTS (STD.)		BELTS (WITH TENSIONER)		SPLIT BUSHING	
		Min	Max	Supplier No.	OEM Part No.	Supplier No.	OEM Part No.	Supplier No.	OEM Part No.
1	2 & 3 Std.	535	725	BX59	59A5001	BX60	100245-10	N/A	N/A
2	2 & 3 Std.	710	965	BX55	63K0501	BX56	100245-11	N/A	N/A
3	3 High & 5	685	865	BX61	93J9801	BX62	57A7701	N/A	N/A
4	3 High & 5	850	1045	BX65	100245-08	BX67	100245-09	H-1-7/16	49M6201
5	5	945	1185	BX61	93J9801	BX62	57A7701	H-1-7/16	49M6201
6	7.5	850	1045	BX66	97J5901	BX67	100245-09	H-1-7/16	49M6201
7	7.5 & 10	945	1185	BX62	57A7701	BX64	97J5801	H-1-7/16	49M6201
8	7.5	1045	1285	BX64	97J5801	BX65	100245-08	H-1-7/16	49M6201
10	10	1045	1285	5VX660	100245-20	5VX680	100245-35	B-1-7/16	100246-01
11	10	1135	1365	5VX660	100245-20	5VX670	100245-21	B-1-7/16	100246-01

D-GAS HEAT COMPONENTS

See SPECIFICATIONS tables or unit nameplate for Btuh capacities. Units are equipped with two identical gas heat sections (gas heat section one and gas heat section two). Flexible pipe will feed supply gas to both sections. If for service the flexible connection must be broken, hand tighten then turn additional 1/4" with a wrench for metal to metal seal (do not overtighten).

NOTE - Do not use thread sealing compound on flex pipe flare connections.

1-Control Box Components A3, A12, A55, T3, T13, K13 and K19

⚠ WARNING	
	Shock hazard. Spark related components contain high voltage which can cause personal injury or death. Disconnect power before servicing. Control is not field repairable. Unsafe operation will result. If control is inoperable, simply replace the entire control.

The main control box (see figure 3) houses the burner controls A3 and A12, A55 Unit Controller, combustion air blower transformers T3 and T13, combustion air blower relay K13 and second heat section relay K19. For a description of the components see section I-A. A more detailed description of burner controls A3 and A12 is given below.

Burner Ignition Control A3, A12

The ignition controls are located in the control box and are manufactured by UTEC or Kidde Fenwal. See table 8 for LED codes.

The ignition control provides three main functions: gas valve control, ignition and flame sensing. The unit will usually ignite on the first attempt; however, the ignition attempt sequence provides three trials for ignition before locking out. The lockout time for the control is 5 minutes. After lockout, the ignition control automatically resets and provides three more attempts at ignition. Manual reset after lockout requires breaking and remaking power to the ignition control. See figure 16 for a normal ignition sequence and figure 17 for the ignition attempt sequence with retries (nominal timings given for simplicity). Specific timings for the ignition controls are shown in figure 18.

TABLE 8

UTEC	
LED Flashes	Indicates
Steady Off	No power or control hardware fault.
Steady On	Power applied. Control OK.
3 Flashes	Ignition lockout from too many trials.
4 Flashes	Ignition lockout from too many flame losses within single call for heat.
5 Flashes	Control hardware fault detected.
Kidde Fenwal	
LED Flashes	Indicates
Steady On	Internal control failure.
2 Flashes	Flame with no call for heat.
3 Flashes	Ignition lockout.
Steady On	Power applied. Control OK.
3 Flashes	Ignition lockout from too many trials.
4 Flashes	Ignition lockout from too many flame losses within single call for heat.

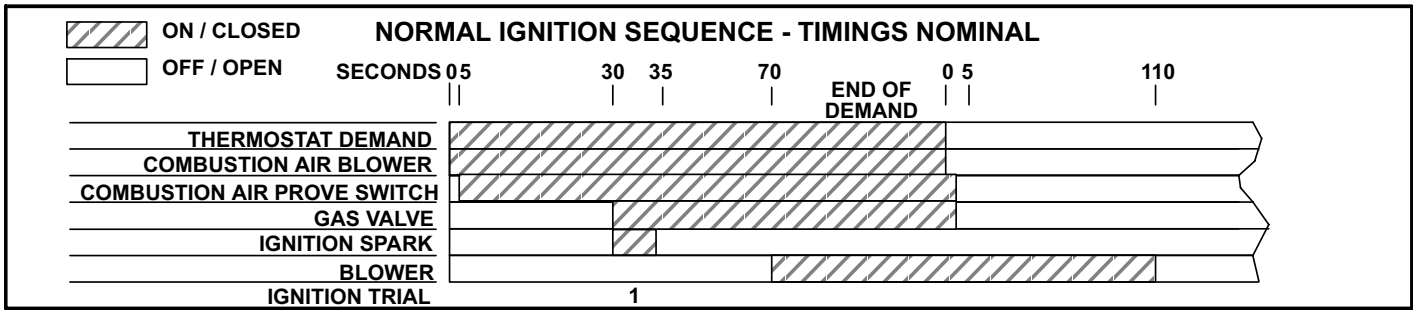

FIGURE 16

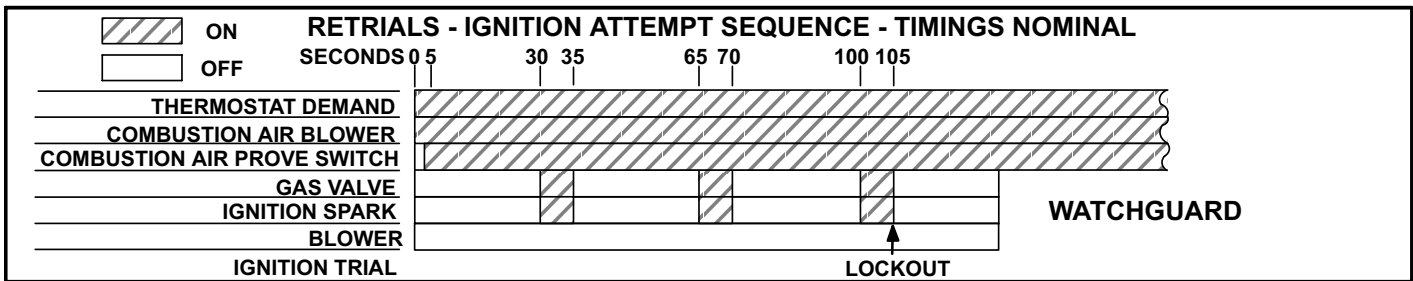

FIGURE 17

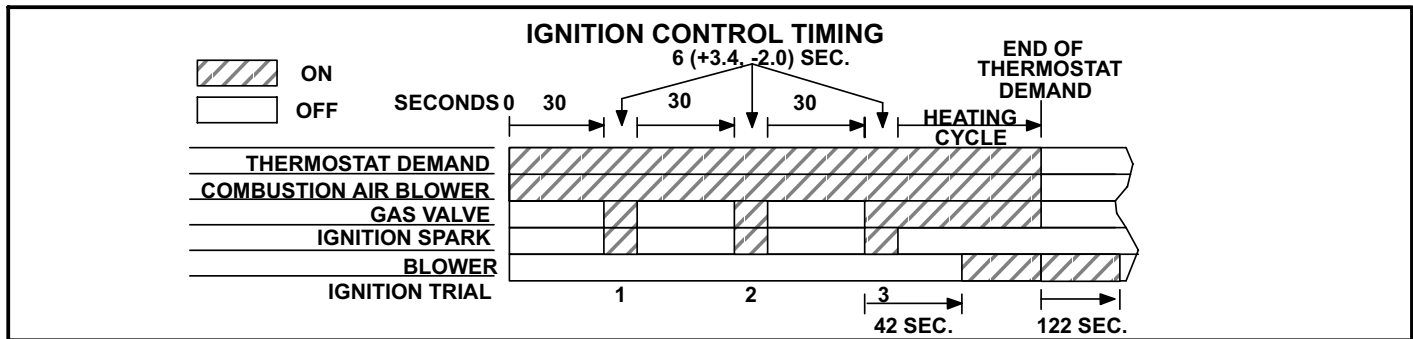

FIGURE 18

Flame rectification sensing is used on all units. Loss of flame during a heating cycle is indicated by an absence of flame signal (0 microamps). If this happens, the control will immediately restart the ignition sequence and then lock out if ignition is not gained after the third trial. See System Service Checks section for flame current measurement.

The control shuts off gas flow immediately in the event of a power failure. Upon restoration of gas and power, the control will restart the ignition sequence and continue until flame is established or system locks out.

On a heating demand, the ignition control is energized by the A55 Unit Controller. The ignition control then allows 30 to 40 seconds for the combustion air blower to vent exhaust gases

from the burners. When the combustion air blower is purging the exhaust gases, the combustion air prove switch is closing proving that the combustion air blower is operating before allowing the ignition control to energize. When the combustion air prove switch is closed and the delay is over, the ignition control activates gas valve, the spark electrode and the flame sensing electrode. Sparking stops immediately after flame is sensed. The combustion air blower continues to operate throughout the heating demand. If the flame fails or if the burners do not ignite, the ignition control will attempt to ignite the burners up to two more times. If ignition cannot be obtained after the third attempt, the control will lock out. The ignition control is not adjustable.

2-Heat Exchanger (Figure 19)

Units use aluminized steel inshot burners with matching tubular aluminized (stainless steel is an option) steel heat exchangers and two-stage redundant gas valves. LGH156/300 uses two eleven-tube/burners for high heat, two six-tube/burners for standard or low heat and two nine-tube/burners for medium heat. Burners in all units use a burner venturi to mix gas and air for proper combustion. Combustion takes place at each tube entrance. As hot combustion gases are drawn upward through each tube by

the combustion air blower, exhaust gases are drawn out the top and fresh air/gas mixture is drawn in at the bottom. Heat is transferred to the air stream from all surfaces of the heat exchanger tubes. The supply air blowers, controlled by the Unit Controller A55, force air across all surfaces of the tubes to extract the heat of combustion. The shape of the tubes ensures maximum heat exchange.

The gas valves accomplish staging by allowing more or less gas to the burners as called for by heating demand.

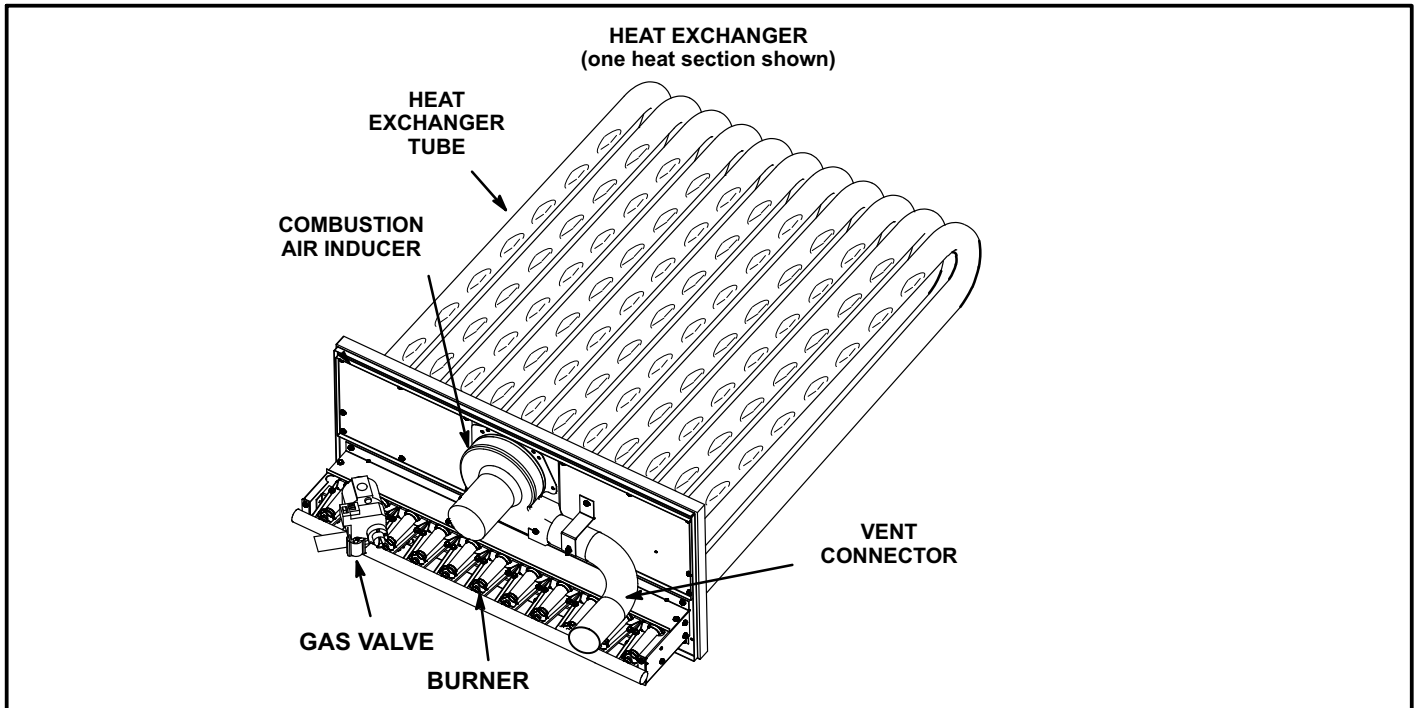

FIGURE 19

3-Burner Assembly (Figure 20)

The burners are controlled by the spark electrode, flame sensing electrode, gas valve and combustion air blower. The spark electrode, flame sensing electrode and gas valve are directly controlled by ignition control. Ignition control and combustion air blower is controlled by Unit Controller A55.

Burners

All units use inshot burners (see figures 20 and 21). Burners are factory set and do not require adjustment. A peep hole with cover is furnished in the heating access panel for flame viewing. Always operate the unit with the access panel in place.

Burners can be removed individually for service. Burner maintenance and service is detailed in the SERVICE CHECKS section of this manual.

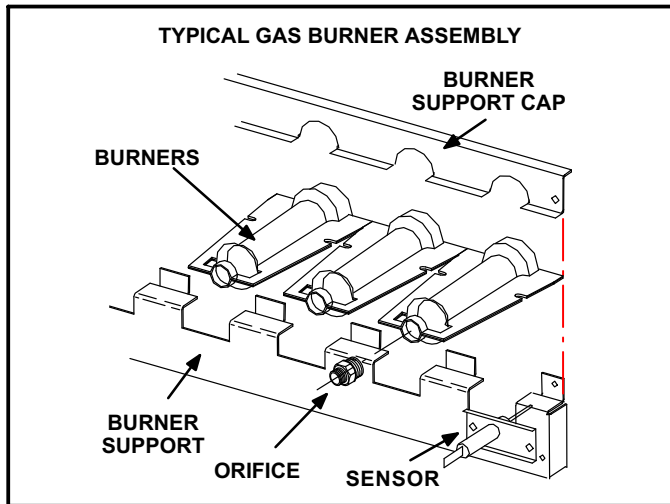

FIGURE 20

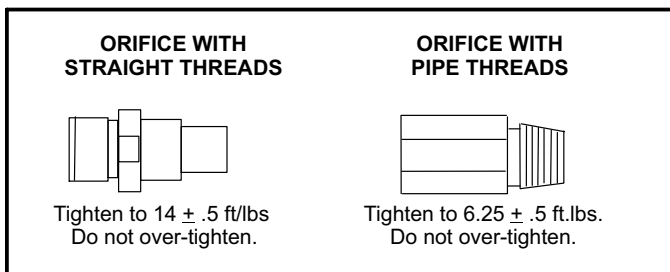

FIGURE 21

Orifice

Each burner uses an orifice (two types figure 21) which is precisely matched to the burner input. **Install only the orifices with the same threads.** The orifice is threaded into the burner manifold. The burner is supported by the orifice and will easily slide off for service.

NOTE-Do not use thread sealing compound on the orifices. Using thread sealing compound may plug the orifices.

Each orifice and burner are sized specifically to the unit. Refer to Lennox Repair Parts Listing for correct sizing information.

NOTE- In primary and secondary high temperature limits S10 and S99 the ignition circuits in both gas heat sections one and two are immediately de-energized when terminals 1-3 open and the indoor blower motor is immediately energized when terminals 1-2 close. This is the primary and secondary safety shut-down function of the unit.

4-Primary High Temperature Limits S10 & S99

S10 is the primary high temperature limit for gas heat section one and S99 is the primary high temperature limit for gas heat section two.

In LGH156/300 units, S10 and S99 are located on the drip shield behind the blower housing. In this location S10 and S99 also serve as secondary limits. See figure 22.

Primary limit S10 is wired to the Unit Controller A55 which energizes burner 1 control (A3), while primary limit S99 is wired to the A55 Unit Controller which energizes burner 2 control (A12). Its N.C. contacts open to de-energize the ignition control when excessive temperature is reached in the blower compartment. At the same time, the N.O. contacts of S10 and S99 close energizing the blower relay coil K3 through control A55. If either limit trips the blower will be energized. Limits settings are factory set and cannot be adjusted. If limit must be replaced same type and set point must be used. See Lennox Repair Parts Handbook.

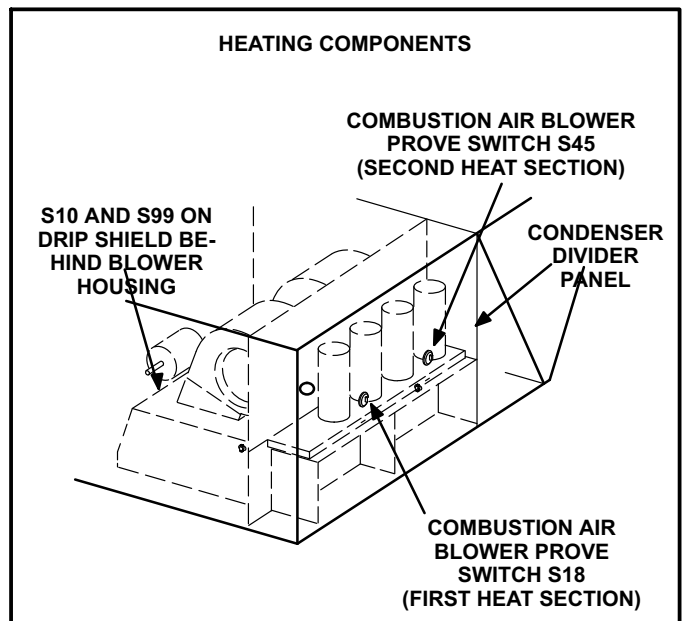

FIGURE 22

5-Flame Rollout Limits S47, S69

Flame rollout limits S47 on first heat section and S69 on second heat section are SPST N.C. high temperature limits located just above the burner air intake opening in the burner enclosures (see figure19). Both switches are wired to the A55 Unit Controller. When S47 or S69 senses flame rollout (indicating a blockage in the combustion air passages), the corresponding flame rollout limit trips and the ignition control immediately closes the gas valve.

Limit S47 and S69 in standard heat units are factory preset to open at 250°F ± 12°F (121.1°C ± 6.7°C) on a temperature rise, while on high heat units both limits open at 270°F ± 12°F (132.2°C ± 6.7°C) on a temperature rise. All flame rollout limits are manual reset.

6-Combustion Air Prove Switches S18, S45

Prove switches S18 (first heat section) and S45 (second heat section) are located in the compressor compartment. Both are identical SPST N.O. switches and monitor combustion air inducer operation. Switch S18 and S45 are wired to the A55 Unit Controller.

The switch closes on a *negative* pressure fall. This negative pressure fall and switch actuation allows the ignition sequence to continue (proves, by closing, that the combustion air inducer is operating before allowing the gas valve to open.) The combustion air prove switch is factory set and not adjustable. The switch will automatically open on a pressure rise (less negative pressure). Table 9 shows prove switch settings.

TABLE 9
S18 & S45 Prove Switch Settings

Close " w.c. (Pa)	Open " w.c. (Pa)
0.25 ± 5 (62.3±12.4)	0.10±5 (24.8±12.4)

7-Combustion Air Inducers B6 & B15

Combustion air blowers B6 on the first heat section and B15 on the second heat section, are identical blowers which provide fresh air to the corresponding burners while clearing the combustion chamber of exhaust gases. The blowers begin operating immediately upon receiving a thermostat demand and are de-energized immediately when thermostat demand is satisfied.

Both combustion air blowers use a 208/230 or 460V single-phase PSC motor and a 4.81in. x 1.25in. (122mm x 32mm) blower wheel. All motors operate at 3200 or 3450 RPM and are equipped with auto-reset overload protection. Blowers are supplied by various manufacturers. Ratings may vary by manufacturer. Specific blower electrical ratings can be found on the unit rating plate.

All combustion air blower motors are sealed and cannot be oiled. The blower cannot be adjusted but can be disassembled for cleaning.

8-Combustion Air Motor Capacitors C3 & C11

The combustion air blower motors in all LGH units require run capacitors. Capacitor C3 is connected to combustion air blower B6 and C11 is connected to combustion air blower B15. Both capacitors are rated at 3 or 4 MFD for 208/230 CAB and 4 MFD for 460V CAB.

9-Gas Valves GV1 & GV3

Gas valves GV1 and GV3 are identical. The gas valves are two-stage redundant valves. Units are equipped with valves manufactured by Honeywell. On both valves first stage (low fire) is quick opening (on and off in less than 3 seconds). On the Honeywell second stage is quick opening. On a call for first stage heat (low fire), the valve is energized by the ignition control simultaneously with the spark electrode. On a call for second stage heat (high fire), the second stage operator is energized directly from A55 (GV1, GV3). The Honeywell valve is adjustable for both low fire and high fire. A manual shut-off knob is provided on the valve for shut-off. Manual shut-off knob immediately closes both stages without delay. Figure 23 shows gas valve components. Table 10 shows factory gas valve regulation for LGH series units. Optional factory installed gas valves for single stage heat only, are available for the LGH156, 180 and 210. Gas valves are wired without W2 eliminating two stage heat.

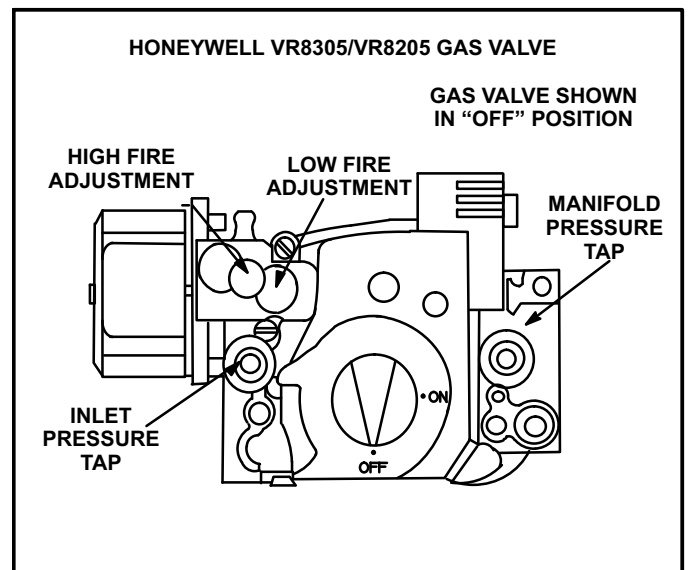

FIGURE 23

TABLE 10
GAS VALVE REGULATION FOR LGH UNITS

Maximum Inlet Pressure	Operating Pressure (outlet) Factory Setting			
	Natural		L.P	
	Low	High	Low	High
13.0"W.C. 3232Pa	1.6±0.2"W.C. 398±50Pa	3.7±0.3"W.C. 920±75Pa	5.5±0.3"W.C. 1368±75Pa	10.5±0.5"W.C. 2611±7124Pa

10-Spark Electrodes

An electrode assembly is used for ignition spark. Two identical electrodes are used (one for each gas heat section). The electrode is mounted through holes on the left-most end of the burner support. The electrode tip protrudes into the flame envelope of the adjacent burner. The electrode assembly is fastened to burner supports and can be removed for service without removing any part of the burners.

During ignition, spark travels through the spark electrode (figure 24) and ignites the left burner. Flame travels from burner to burner until all are lit.

The spark electrode is connected to the ignition control by a 8 mm silicone-insulated stranded high voltage wire. The wire uses 1/4" (6.35 mm) female quick connect on the electrode end and female spark plug-type terminal on the ignition control end.

NOTE- IN ORDER TO MAXIMIZE SPARK ENERGY TO ELECTRODE, HIGH VOLTAGE WIRE SHOULD TOUCH UNIT CABINET AS LITTLE AS POSSIBLE.

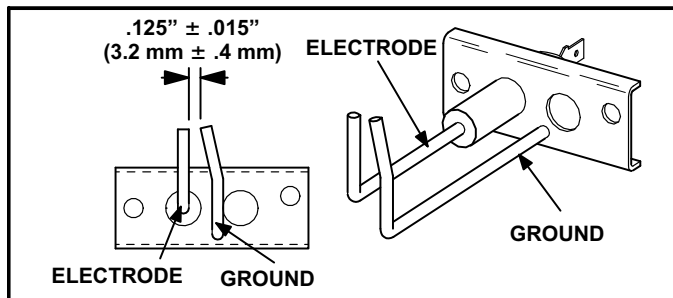

FIGURE 24

11-Flame Sensors

A flame sensor is located on the right side of each burner support. The sensor is mounted through a hole in the burner support and the tip protrudes into the flame envelope of the right most burner. The sensor assembly is fastened to burner supports and can be removed for service without removing any part of the burners.

When flame is sensed by the flame sensor (indicated by microamp signal through the flame) sparking stops immediately. During operation, flame is sensed by current passed along the ground electrode (located on the spark electrode), through the flame and into the sensing electrode. The ignition control allows the gas valve to stay open as long as a flame signal (current passed through the flame) is sensed.

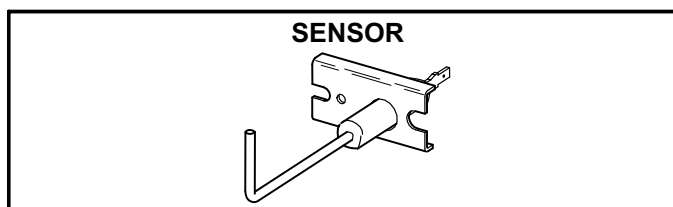

FIGURE 25

II-PLACEMENT AND INSTALLATION

Make sure the unit is installed in accordance with the installation instructions and all applicable codes. See accessories section for conditions requiring use of the optional roof mounting frame.

III-CHARGING

⚠ WARNING

Refrigerant can be harmful if it is inhaled. Refrigerant must be used and recovered responsibly. Failure to follow this warning may result in personal injury or death.

⚠ IMPORTANT

Units equipped with Hot Gas Re-Heat system MUST be charged in standard cooling mode.

A-Aluminum Coils

WARNING-Do not exceed nameplate charge under any condition.

This unit is factory charged and should require no further adjustment. If the system requires additional refrigerant, reclaim the charge, evacuate the system, and add required nameplate charge.

NOTE - System charging is not recommended below 60°F (15°C). In temperatures below 60°F (15°C), the charge must be weighed into the system.

If weighing facilities are not available, or to check the charge, use the following procedure:

IMPORTANT - Charge unit in standard cooling mode.

1. Make sure outdoor coil is clean. Attach gauge manifolds and operate unit at full CFM in cooling mode with economizer disabled until system stabilizes (approximately five minutes). Make sure all outdoor air dampers are closed.
2. Check each system separately with all stages operating. Compare the normal operating pressures (see tables 11 - 23) to the pressures obtained from the gauges. Check unit components if there are significant differences.
3. Measure the outdoor ambient temperature and the suction pressure. Refer to the appropriate circuit charging curves to determine a target liquid temperature.

Note - Pressures are listed for sea level applications.

4. Use the same thermometer to accurately measure the liquid temperature (in the outdoor section).
 - If measured liquid temperature is higher than the target liquid temperature, add refrigerant to the system.
 - If measured liquid temperature is lower than the target liquid temperature, recover some refrigerant from the system.
5. Add or remove charge in increments. Allow the system to stabilize each time refrigerant is added or removed.
6. Continue the process until measured liquid temperature agrees with the target liquid temperature. Do not go below the target liquid temperature when adjusting charge. Note that suction pressure can change as charge is adjusted.

7. Example LGH/LCH180H Circuit 1: At 95°F outdoor ambient and a measured suction pressure of 130psig, the target liquid temperature is 96.5°F. For a measured liquid temperature of 106°F, add charge in increments until measured liquid temperature agrees with the target liquid temperature.

**TABLE 11
LGH/LCH156H NORMAL OPERATING PRESSURES - ALUMINUM COIL**

Normal Operating Pressures												
	Outdoor Coil Entering Air Temperature											
	65 °F		75 °F		85 °F		95 °F		105 °F		115 °F	
	Suct (psig)	Disc (psig)	Suct (psig)	Disc (psig)	Suct (psig)	Disc (psig)	Suct (psig)	Disc (psig)	Suct (psig)	Disc (psig)	Suct (psig)	Disc (psig)
Circuit 1	110	241	112	279	115	321	117	367	119	419	122	472
	118	245	121	282	124	324	127	370	129	420	131	474
	137	255	140	292	142	333	145	378	148	431	152	484
	154	266	160	304	163	346	163	392	171	441	174	496
Circuit 2	111	249	112	287	113	328	116	374	118	423	121	474
	119	253	120	291	122	332	124	378	127	428	129	481
	137	263	139	301	142	342	145	387	146	438	149	490
	153	276	158	313	162	356	164	402	167	451	171	505
Circuit 3	115	256	116	294	118	335	120	381	122	429	124	480
	123	261	125	299	128	340	130	386	132	436	133	488
	140	273	143	311	146	353	149	398	152	449	154	502
	157	284	162	324	166	367	169	413	171	462	174	515

**TABLE 12
LGH/LCH156H REHEAT NORMAL OPERATING PRESSURES - ALUMINUM COIL**

Normal Operating Pressures												
	Outdoor Coil Entering Air Temperature											
	65 °F		75 °F		85 °F		95 °F		105 °F		115 °F	
	Suct (psig)	Disc (psig)	Suct (psig)	Disc (psig)	Suct (psig)	Disc (psig)	Suct (psig)	Disc (psig)	Suct (psig)	Disc (psig)	Suct (psig)	Disc (psig)
Circuit 1	113	238	113	278	113	342	115	380	117	450	119	540
	121	242	124	279	123	324	124	375	125	438	127	521
	138	250	141	287	144	328	146	372	145	428	147	492
	156	261	160	298	164	338	167	383	170	432	171	488
Circuit 2	111	244	112	284	114	329	116	384	119	451	121	537
	120	246	121	286	122	331	124	383	127	445	130	518
	138	254	140	290	142	335	143	384	145	439	148	504
	157	264	161	300	164	342	166	390	168	442	170	499
Circuit 3	114	249	115	291	116	340	117	397	120	465	121	552
	123	252	124	294	125	342	126	396	128	459	131	538
	142	261	144	300	145	345	146	397	108	454	150	521
	161	272	165	311	168	355	170	404	172	458	175	516

**TABLE 13
LGH/LCH156H VAV NORMAL OPERATING PRESSURES - ALUMINUM COIL**

Normal Operating Pressures												
	Outdoor Coil Entering Air Temperature											
	65 °F		75 °F		85 °F		95 °F		105 °F		115 °F	
	Suct (psig)	Disc (psig)	Suct (psig)	Disc (psig)	Suct (psig)	Disc (psig)	Suct (psig)	Disc (psig)	Suct (psig)	Disc (psig)	Suct (psig)	Disc (psig)
Circuit 1	101	232	103	271	104	315	106	372	109	434	111	511
	109	234	111	275	113	317	114	367	118	425	119	500
	128	239	130	277	132	319	134	367	136	420	139	481
	141	245	147	284	153	326	156	373	159	424	158	479
Circuit 2	108	235	110	273	111	320	113	370	115	441	117	531
	117	238	119	276	121	319	123	367	125	426	126	506
	134	246	138	283	140	325	142	372	144	426	146	489
	149	253	156	292	161	334	164	380	167	433	166	490
Circuit 3	119	252	121	291	123	336	125	386	126	445	129	507
	129	256	131	295	133	339	134	387	137	445	139	510
	146	264	150	303	153	346	156	394	158	446	161	505
	161	274	167	313	172	357	176	404	180	456	181	513

**TABLE 14
LGH/LCH180H CAV/STAGED NORMAL OPERATING PRESSURES - ALUMINUM COIL**

Normal Operating Pressures												
	Outdoor Coil Entering Air Temperature											
	65 °F		75 °F		85 °F		95 °F		105 °F		115 °F	
	Suct (psig)	Disc (psig)	Suct (psig)	Disc (psig)	Suct (psig)	Disc (psig)	Suct (psig)	Disc (psig)	Suct (psig)	Disc (psig)	Suct (psig)	Disc (psig)
Circuit 1	104	235	106	275	105	326	106	389	110	466	113	552
	114	238	118	275	115	319	117	378	119	447	122	527
	130	245	134	281	136	320	136	365	138	424	141	483
	146	253	153	289	157	330	159	374	162	421	165	478
Circuit 2	100	241	103	281	104	327	105	379	109	442	112	513
	111	244	112	282	113	327	115	379	116	445	119	507
	128	249	132	286	131	331	132	377	135	434	139	488
	144	257	151	295	154	336	158	382	158	439	161	498
Circuit 3	106	241	110	278	110	326	111	380	114	447	117	536
	118	242	115	282	120	326	120	380	123	437	126	512
	134	250	138	287	140	328	139	378	142	431	145	491
	151	260	157	298	160	340	163	385	165	435	167	494

**TABLE 15
LGH/LCH180H CAV/STAGED REHEAT NORMAL OPERATING PRESSURES - ALUMINUM COIL**

Normal Operating Pressures												
	Outdoor Coil Entering Air Temperature											
	65 °F		75 °F		85 °F		95 °F		105 °F		115 °F	
	Suct (psig)	Disc (psig)	Suct (psig)	Disc (psig)	Suct (psig)	Disc (psig)	Suct (psig)	Disc (psig)	Suct (psig)	Disc (psig)	Suct (psig)	Disc (psig)
Circuit 1	103	242	106	277	109	319	110	374	112	444	-	-
	112	243	114	279	117	325	119	368	120	437	122	514
	130	249	133	286	136	326	137	374	139	425	142	489
	143	275	149	306	155	334	158	378	158	417	166	485
Circuit 2	107	249	109	284	110	330	111	374	113	430	-	-
	115	252	116	288	119	334	120	378	121	430	122	492
	131	260	134	297	136	337	138	380	140	436	143	488
Circuit 3	143	287	148	317	156	346	160	391	157	428	167	500
	111	246	112	285	112	342	114	403	116	489	-	-
	119	247	120	288	122	337	123	389	124	471	129	551
	138	254	140	292	142	336	143	383	143	450	147	517
	154	265	159	302	163	341	165	389	168	441	171	505

**TABLE 16
LGH/LCH180H VAV NORMAL OPERATING PRESSURES - ALUMINUM COIL**

Normal Operating Pressures												
	Outdoor Coil Entering Air Temperature											
	65 °F		75 °F		85 °F		95 °F		105 °F		115 °F	
	Suct (psig)	Disc (psig)	Suct (psig)	Disc (psig)	Suct (psig)	Disc (psig)	Suct (psig)	Disc (psig)	Suct (psig)	Disc (psig)	Suct (psig)	Disc (psig)
Circuit 1	102	234	104	273	106	311	108	358	111	411	114	471
	110	235	112	276	114	314	116	360	119	410	122	470
	123	242	127	283	130	320	132	367	135	418	138	476
	135	251	141	290	145	333	149	380	152	431	155	486
Circuit 2	103	236	105	273	107	315	109	363	111	417	113	472
	110	239	113	276	115	317	117	362	120	415	122	475
	123	246	127	283	132	324	135	370	138	421	141	477
	134	253	141	290	146	332	152	377	156	429	160	481
Circuit 3	115	243	117	280	119	321	121	369	124	419	126	477
	123	246	126	282	128	324	130	368	133	419	135	477
	136	256	141	293	145	334	152	384	152	430	155	485
	150	272	155	304	161	345	166	391	171	439	175	490

**TABLE 17
LGH/LCH210H NORMAL OPERATING PRESSURES - ALUMINUM COIL**

Normal Operating Pressures												
	Outdoor Coil Entering Air Temperature											
	65 °F		75 °F		85 °F		95 °F		105 °F		115 °F	
	Suct (psig)	Disc (psig)	Suct (psig)	Disc (psig)	Suct (psig)	Disc (psig)	Suct (psig)	Disc (psig)	Suct (psig)	Disc (psig)	Suct (psig)	Disc (psig)
Circuit 1	110	228	113	262	114	302	116	349	118	402	119	466
	119	231	121	266	123	305	125	352	127	405	128	466
	136	238	139	271	141	312	143	358	146	409	149	464
	152	246	157	277	161	319	165	363	169	414	171	472
Circuit 2	112	232	111	267	113	312	115	358	116	414	119	479
	121	235	123	272	125	311	127	357	126	415	129	476
	137	242	141	278	144	317	146	365	149	415	151	471
	153	253	159	289	164	333	168	374	171	425	174	478
Circuit 3	105	241	106	284	108	327	110	375	112	429	115	489
	112	244	115	282	118	323	121	369	121	428	123	487
	130	251	132	289	135	332	138	378	141	428	145	484
	146	261	151	297	156	339	159	386	163	437	165	495

**TABLE 18
LGH/LCH210H REHEAT NORMAL OPERATING PRESSURES - ALUMINUM COIL**

Normal Operating Pressures												
	Outdoor Coil Entering Air Temperature											
	65 °F		75 °F		85 °F		95 °F		105 °F		115 °F	
	Suct (psig)	Disc (psig)	Suct (psig)	Disc (psig)	Suct (psig)	Disc (psig)	Suct (psig)	Disc (psig)	Suct (psig)	Disc (psig)	Suct (psig)	Disc (psig)
Circuit 1	109	234	111	270	114	311	115	357	118	410	121	472
	119	237	120	274	122	314	125	360	127	412	130	472
	137	246	140	281	143	321	146	365	146	417	150	473
	152	260	158	292	162	330	166	373	170	421	173	476
Circuit 2	113	240	115	276	114	320	115	369	117	420	122	478
	122	244	123	281	125	321	125	369	127	423	130	481
	139	254	143	291	146	330	148	374	150	424	152	480
	154	267	160	302	165	341	169	384	172	431	176	486
Circuit 3	111	239	113	277	116	319	115	371	117	427	121	488
	119	243	128	281	123	326	125	374	127	430	130	489
	135	252	139	291	143	332	145	379	148	432	150	490
	149	265	155	303	160	344	164	390	168	438	173	496

**TABLE 19
LGH/LCH240H CAV/STAGED NORMAL OPERATING PRESSURES - ALUMINUM COIL**

Normal Operating Pressures												
	Outdoor Coil Entering Air Temperature											
	65 °F		75 °F		85 °F		95 °F		105 °F		115 °F	
	Suct (psig)	Disc (psig)	Suct (psig)	Disc (psig)	Suct (psig)	Disc (psig)	Suct (psig)	Disc (psig)	Suct (psig)	Disc (psig)	Suct (psig)	Disc (psig)
Circuit 1	107	249	109	286	111	331	113	391	116	450	118	513
	115	251	118	285	120	332	122	383	125	443	128	513
	134	255	136	291	139	334	141	383	143	441	146	506
	156	269	160	305	164	352	163	393	166	451	168	508
Circuit 2	105	236	106	277	109	320	112	373	114	445	116	538
	114	239	116	275	117	323	119	372	122	438	125	530
	131	245	134	279	136	322	138	372	140	427	144	489
	153	257	157	291	161	337	161	377	164	433	167	486
Circuit 3	110	247	112	286	114	330	115	386	117	444	119	507
	119	251	121	289	122	334	123	384	126	442	128	512
	136	259	139	298	141	341	144	389	145	445	147	506
	157	276	162	314	166	358	166	399	168	457	170	511
Circuit 4	104	240	106	276	108	319	110	372	111	435	115	492
	113	244	114	280	117	320	117	371	120	432	123	497
	128	251	131	289	133	331	136	376	139	430	142	486
	149	264	154	301	157	345	157	387	161	442	165	493

**TABLE 20
LGH/LCH240H CAV/STAGED REHEAT NORMAL OPERATING PRESSURES - ALUMINUM COIL**

Normal Operating Pressures												
	Outdoor Coil Entering Air Temperature											
	65 °F		75 °F		85 °F		95 °F		105 °F		115 °F	
	Suct (psig)	Disc (psig)	Suct (psig)	Disc (psig)	Suct (psig)	Disc (psig)	Suct (psig)	Disc (psig)	Suct (psig)	Disc (psig)	Suct (psig)	Disc (psig)
Circuit 1	111	252	112	288	112	334	114	386	116	441	118	502
	119	256	121	294	122	337	123	387	125	440	127	499
	136	266	140	303	142	345	145	391	147	446	148	499
	140	268	155	314	160	356	164	402	168	451	172	505
Circuit 2	108	246	109	282	110	326	112	379	114	438	116	512
	116	248	118	286	119	330	120	379	122	426	125	501
	133	257	137	294	138	335	140	382	142	440	145	494
	138	259	152	303	158	345	161	390	165	437	168	492
Circuit 3	115	248	117	285	118	327	121	375	124	426	127	479
	121	252	125	290	128	332	129	378	131	429	135	484
	135	260	140	299	144	341	148	388	152	442	153	493
	141	262	154	308	160	353	164	399	169	450	173	504
Circuit 4	112	243	114	278	115	319	118	365	116	425	120	479
	118	246	122	283	125	324	126	369	127	418	129	479
	133	254	137	291	141	332	145	377	148	430	150	481
	138	257	151	301	157	344	161	389	166	437	170	491

**TABLE 21
LGH/LCH240H VAV NORMAL OPERATING PRESSURES - ALUMINUM COIL**

Normal Operating Pressures												
	Outdoor Coil Entering Air Temperature											
	65 °F		75 °F		85 °F		95 °F		105 °F		115 °F	
	Suct (psig)	Disc (psig)	Suct (psig)	Disc (psig)	Suct (psig)	Disc (psig)	Suct (psig)	Disc (psig)	Suct (psig)	Disc (psig)	Suct (psig)	Disc (psig)
Circuit 1	98	238	101	276	102	318	105	367	108	413	110	467
	107	240	109	278	111	321	113	368	116	418	119	474
	124	248	127	284	129	325	132	372	134	422	137	478
	143	255	145	293	148	333	152	380	154	428	157	482
Circuit 2	101	230	103	267	105	309	108	360	110	407	113	462
	109	232	111	268	113	311	116	358	118	411	121	467
	125	239	129	274	132	315	135	362	137	413	140	471
	141	245	145	283	150	323	154	371	158	419	161	474
Circuit 3	113	249	115	287	117	329	119	381	121	432	123	488
	122	252	124	290	126	333	127	381	129	434	131	492
	139	263	142	299	145	341	147	388	149	441	152	498
	159	275	159	313	164	353	167	402	169	451	172	508
Circuit 4	117	242	119	281	120	324	122	377	124	428	127	486
	125	246	127	285	129	329	131	377	133	430	135	490
	139	256	145	293	148	335	151	389	153	436	156	495
	158	268	161	308	166	348	171	396	174	446	177	504

**TABLE 22
LGH/LCH300S NORMAL OPERATING PRESSURES - ALUMINUM COIL**

Normal Operating Pressures												
	Outdoor Coil Entering Air Temperature											
	65 °F		75 °F		85 °F		95 °F		105 °F		115 °F	
	Suct (psig)	Disc (psig)	Suct (psig)	Disc (psig)	Suct (psig)	Disc (psig)	Suct (psig)	Disc (psig)	Suct (psig)	Disc (psig)	Suct (psig)	Disc (psig)
Circuit 1	105	248	109	283	109	330	110	381	112	432	114	486
	114	250	117	291	117	338	119	384	121	432	123	487
	127	253	134	300	137	343	140	388	141	444	144	501
	142	265	149	308	154	349	159	399	163	449	167	503
Circuit 2	103	236	105	272	107	318	108	373	109	428	111	484
	112	238	114	278	116	325	116	374	118	425	120	482
	127	246	131	285	135	327	137	377	140	433	142	491
	141	254	146	294	150	332	156	385	160	437	164	495
Circuit 3	104	258	105	302	107	345	109	399	111	456	114	519
	112	263	114	308	115	354	117	403	120	463	123	524
	131	297	133	320	136	367	138	410	140	465	142	526
	147	313	147	334	152	381	156	423	160	476	165	537
Circuit 4	100	246	103	289	104	329	105	381	107	437	110	500
	109	253	110	293	112	337	114	383	116	443	119	505
	126	281	127	303	131	349	133	391	136	443	139	499
	141	296	143	321	149	370	152	410	157	462	161	521

**TABLE 23
LGH/LCH300S REHEAT NORMAL OPERATING PRESSURES - ALUMINUM COIL**

Normal Operating Pressures												
	Outdoor Coil Entering Air Temperature											
	65 °F		75 °F		85 °F		95 °F		105 °F		115 °F	
	Suct (psig)	Disc (psig)	Suct (psig)	Disc (psig)	Suct (psig)	Disc (psig)	Suct (psig)	Disc (psig)	Suct (psig)	Disc (psig)	Suct (psig)	Disc (psig)
Circuit 1	108	259	110	299	112	353	113	396	114	452	117	510
	118	263	119	303	120	348	123	396	125	450	128	510
	133	275	137	314	139	357	142	407	144	460	148	516
	149	288	154	326	159	370	162	416	166	468	171	527
Circuit 2	106	253	107	293	109	348	111	389	113	445	115	509
	116	257	118	296	119	340	120	391	122	445	125	506
	133	267	136	307	139	349	142	398	142	452	145	512
	148	280	153	318	158	360	161	407	164	460	168	521
Circuit 3	110	258	109	304	110	363	111	405	113	463	116	535
	119	263	122	304	123	350	122	405	124	463	126	526
	135	274	139	316	142	360	145	410	148	463	151	520
	149	288	155	329	159	375	163	422	168	475	172	536
Circuit 4	105	251	107	290	107	347	109	390	110	449	113	511
	114	256	117	294	119	338	119	388	121	446	123	509
	128	268	133	308	136	349	139	397	142	449	144	510
	141	282	147	320	152	363	156	408	160	462	165	521

LGH/LCH156 CAV/STAGED CHARGING CURVE CIRCUIT 1 - 580551-03 Outdoor Temperature (°F)

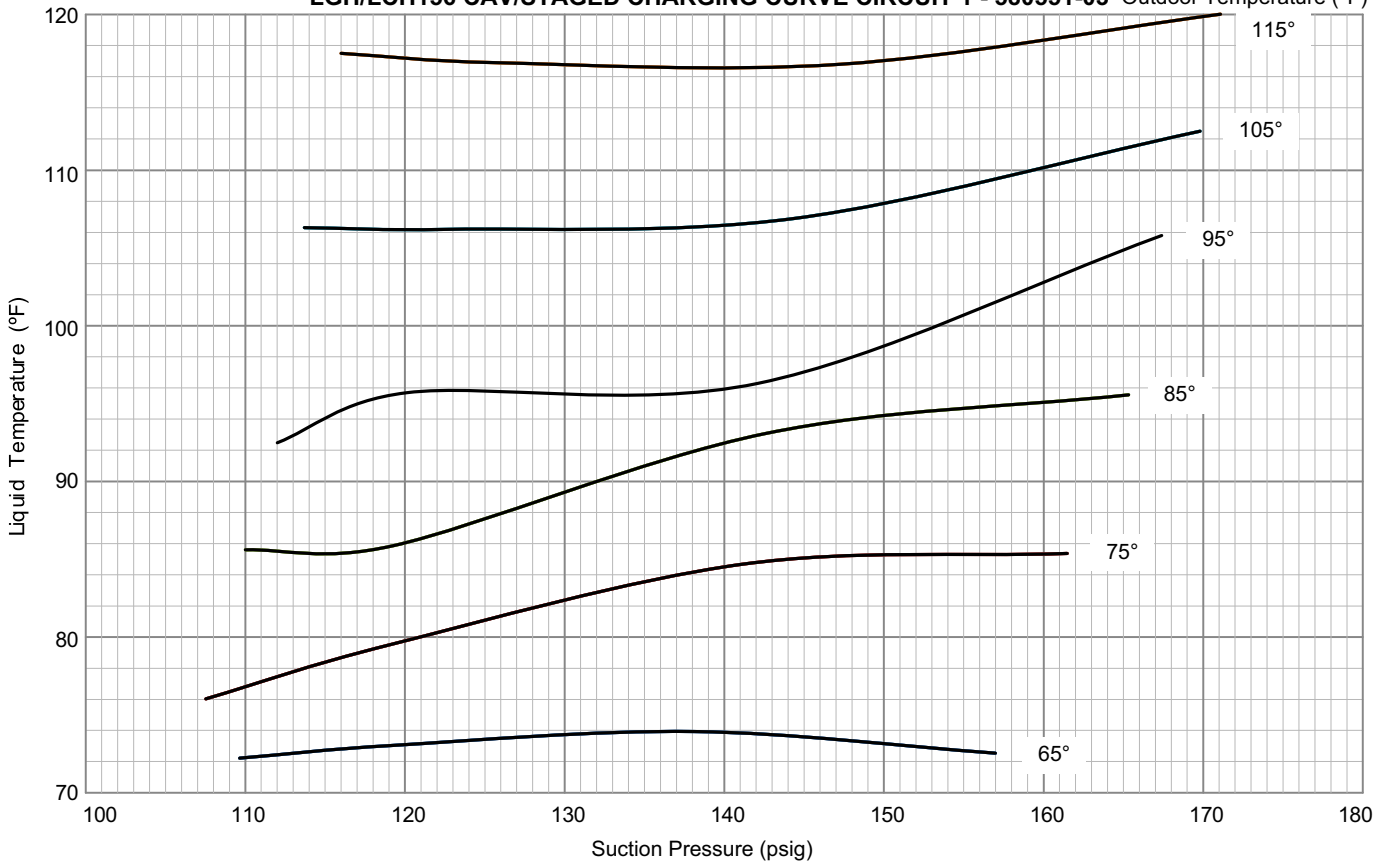

LGH/LCH156 CAV/STAGED CHARGING CURVE CIRCUIT 2 - 580551-03 Outdoor Temperature (°F)

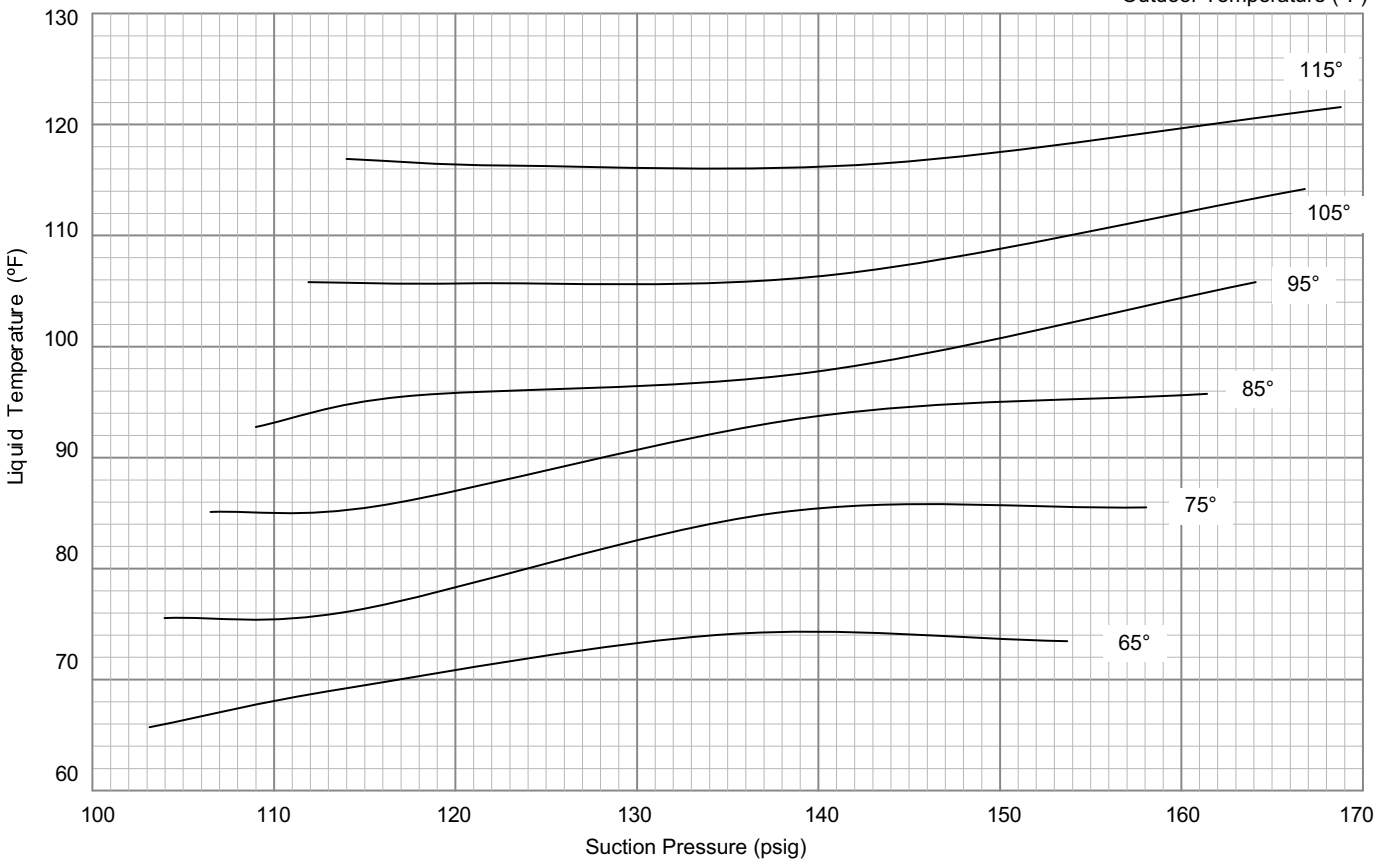

LGH/LCH156 CAV/STAGED CHARGING CURVE CIRCUIT 3 - 580551-03 Outdoor Temperature (°F)

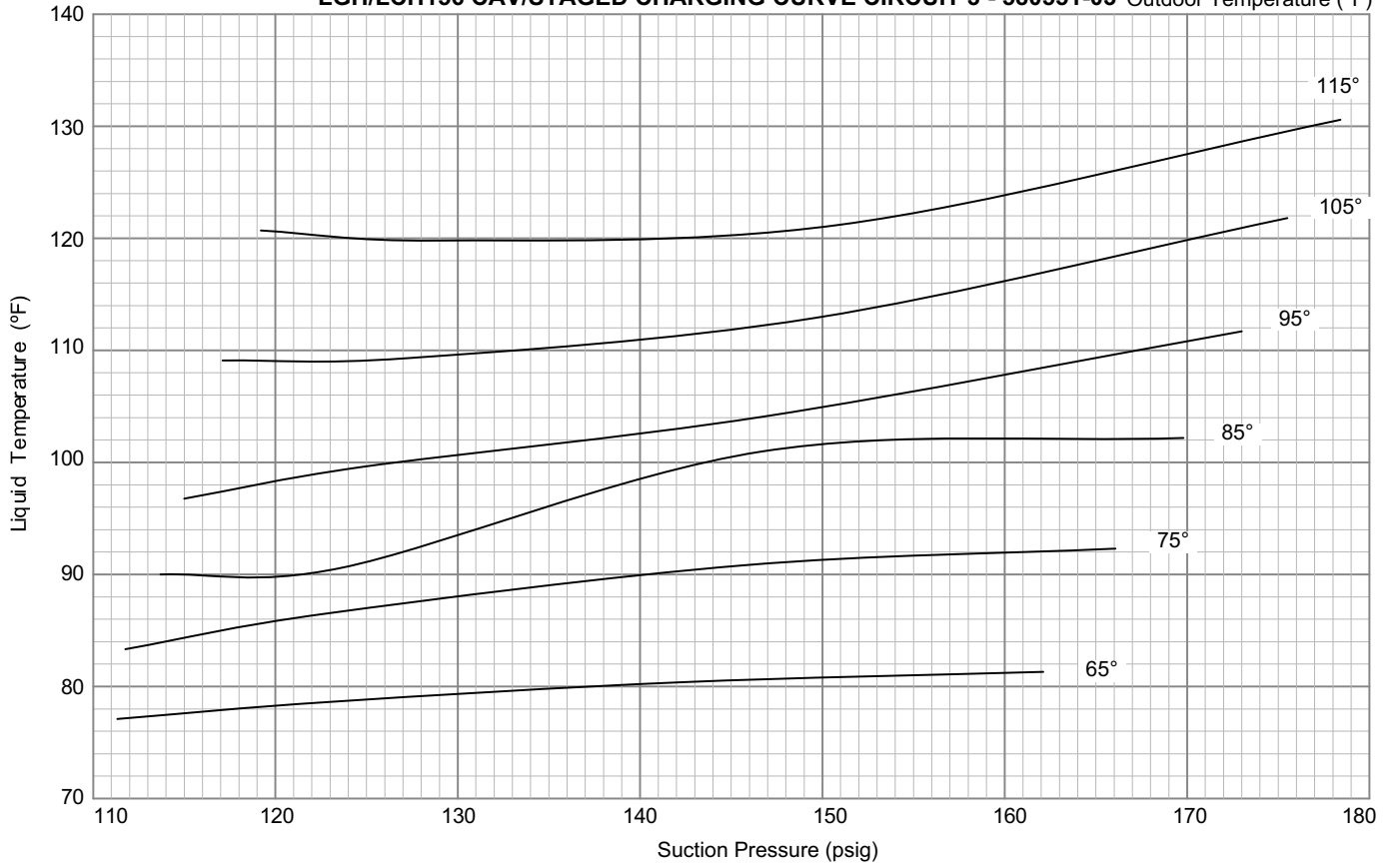

LGH/LCH156 CAV/STAGED REHEAT CHARGING CURVES CIRCUIT 1 - 580907-02 Outdoor Temperature (°F)

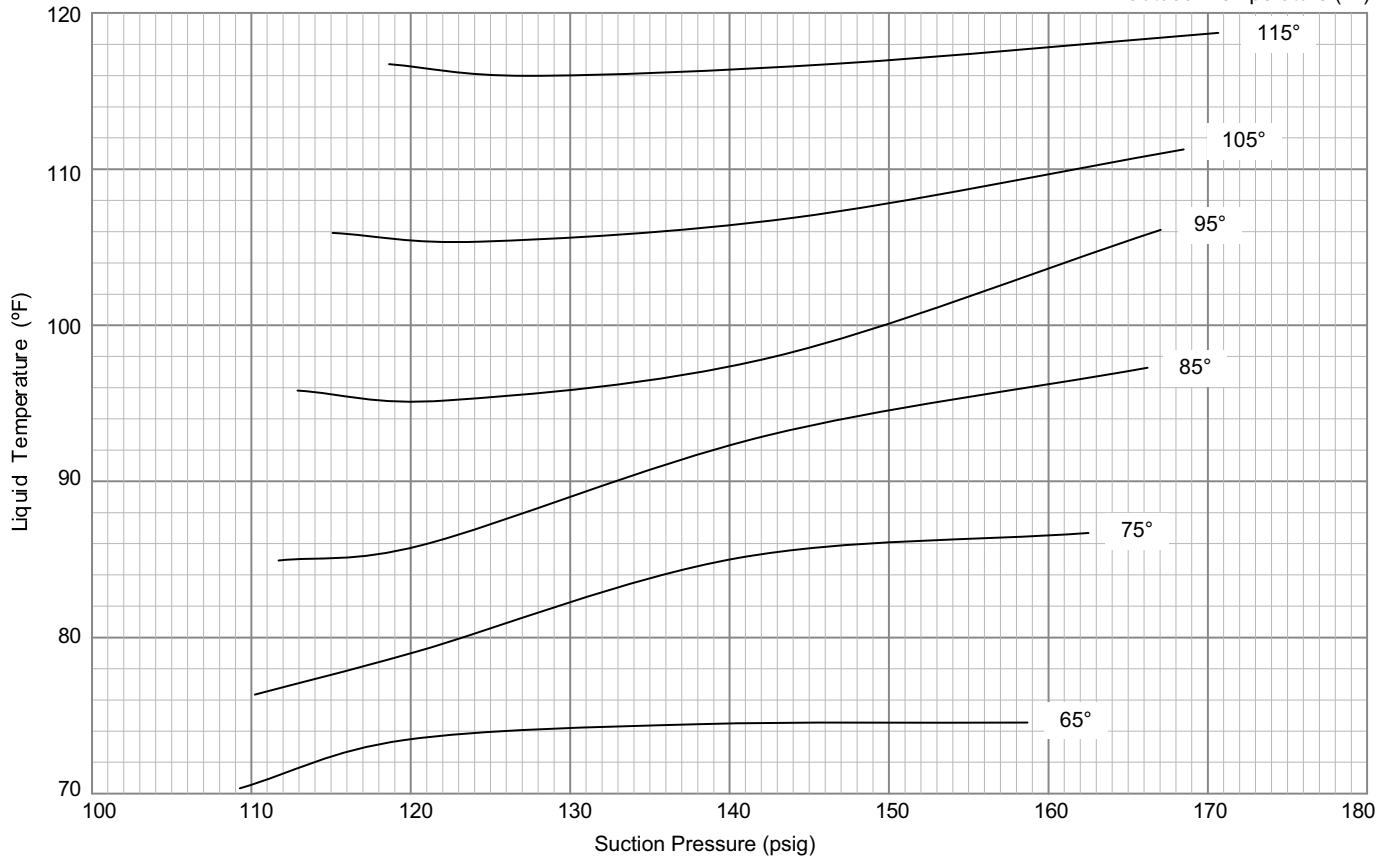

LGH/LCH156 CAV/STAGED REHEAT CHARGING CURVE CIRCUIT 2 - 580907-02 Outdoor Temperature (°F)

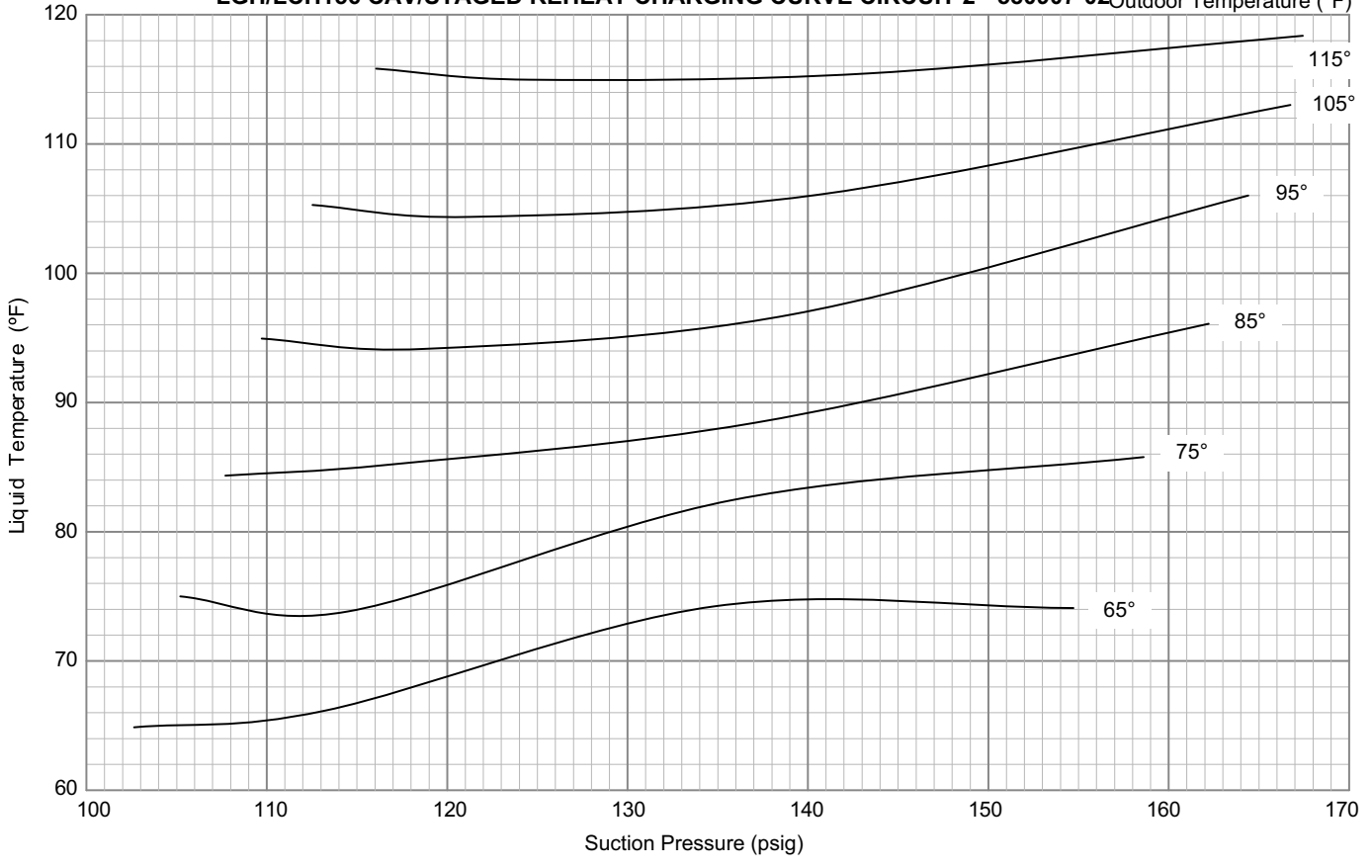

LGH/LCH156 CAV/STAGED REHEAT CHARGING CURVE CIRCUIT 3 - 580907-02 Outdoor Temperature (°F)

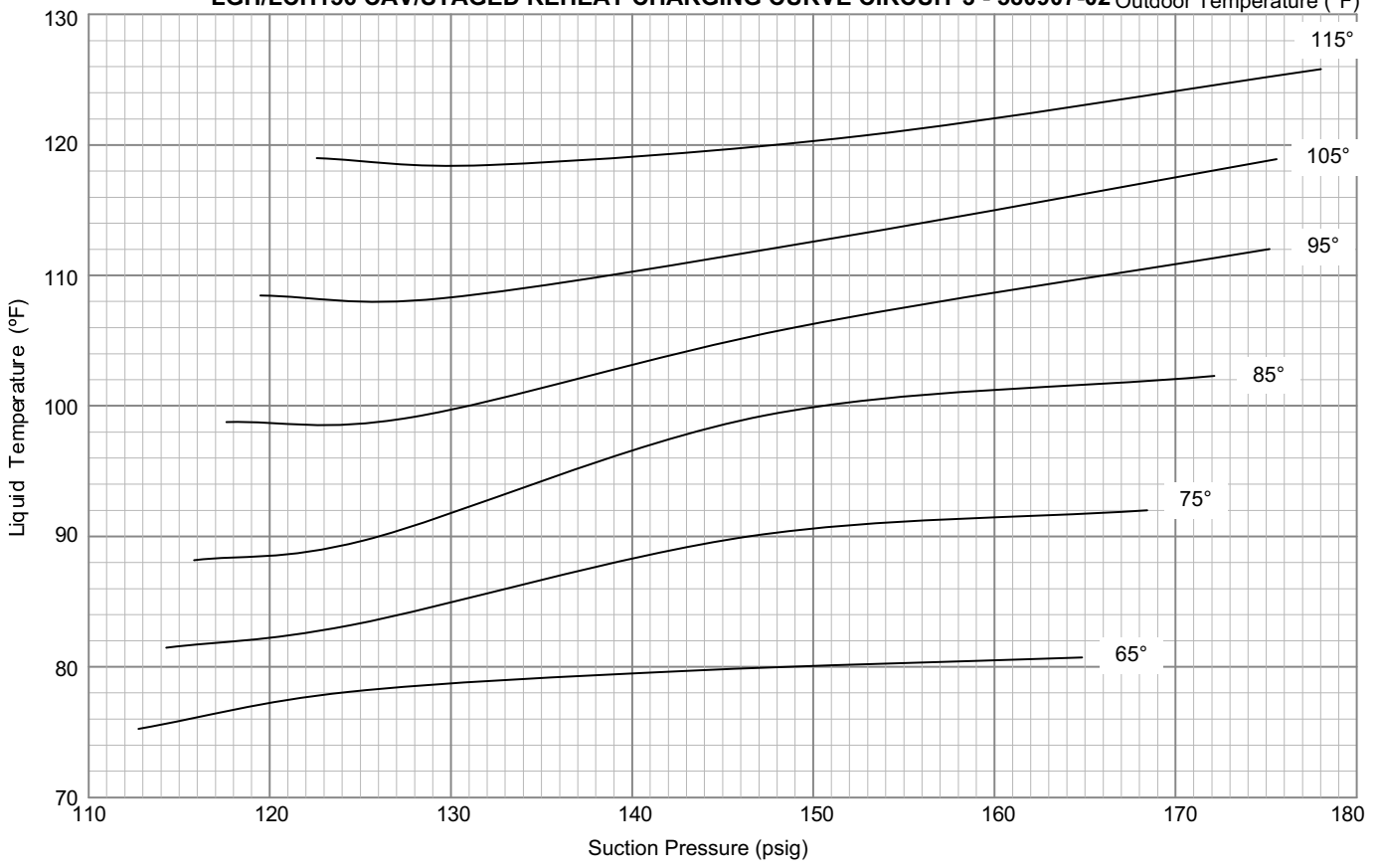

LGH/LCH156 VAV CHARGING CURVE CIRCUIT 1 - 580950-01

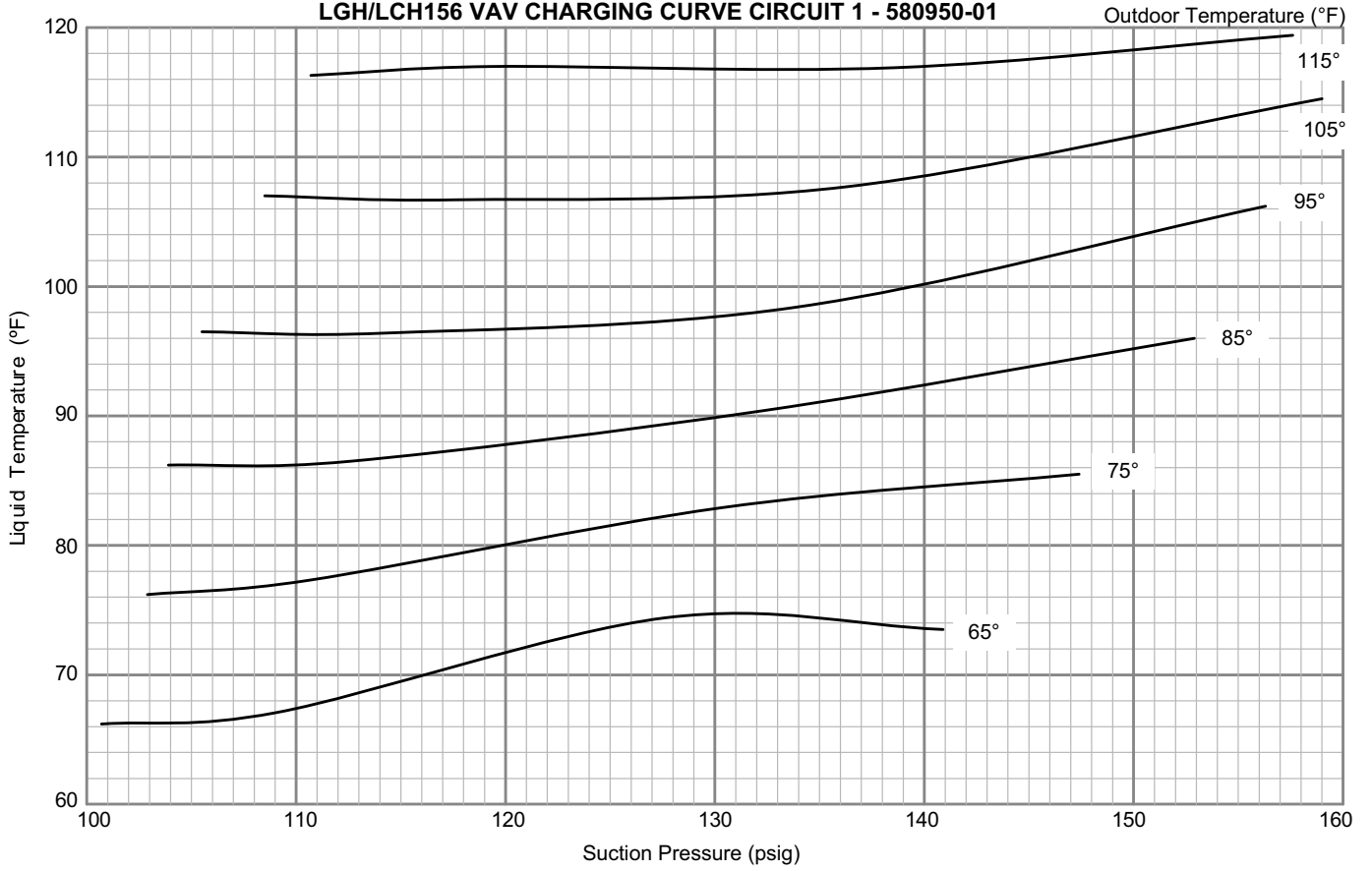

LGH/LCH156 VAV CHARGING CURVE CIRCUIT 2 - 580950-01

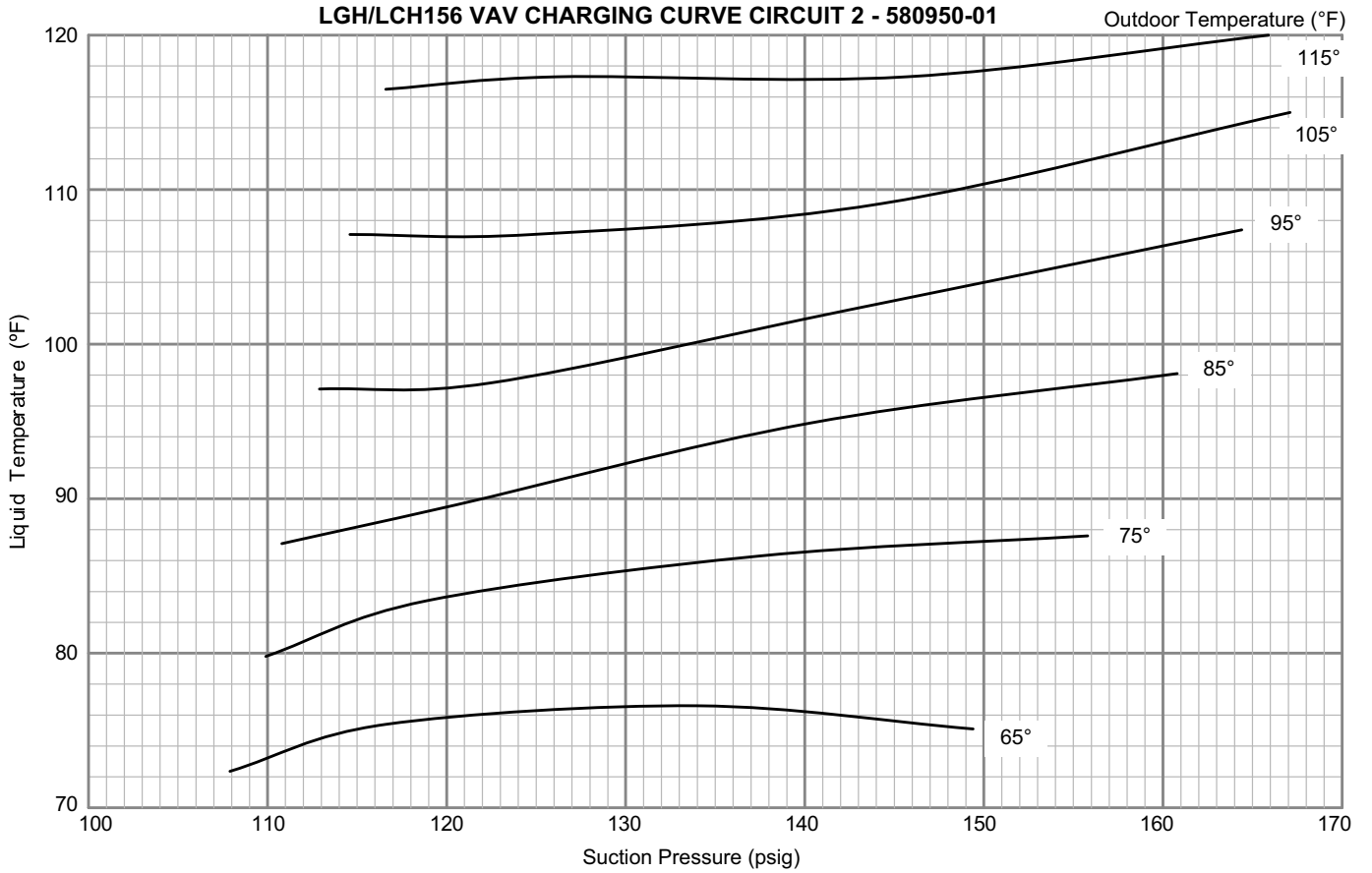

LGH/LCH156 VAV CHARGING CURVE CIRCUIT 3 - 580950-01

Outdoor Temperature (°F)

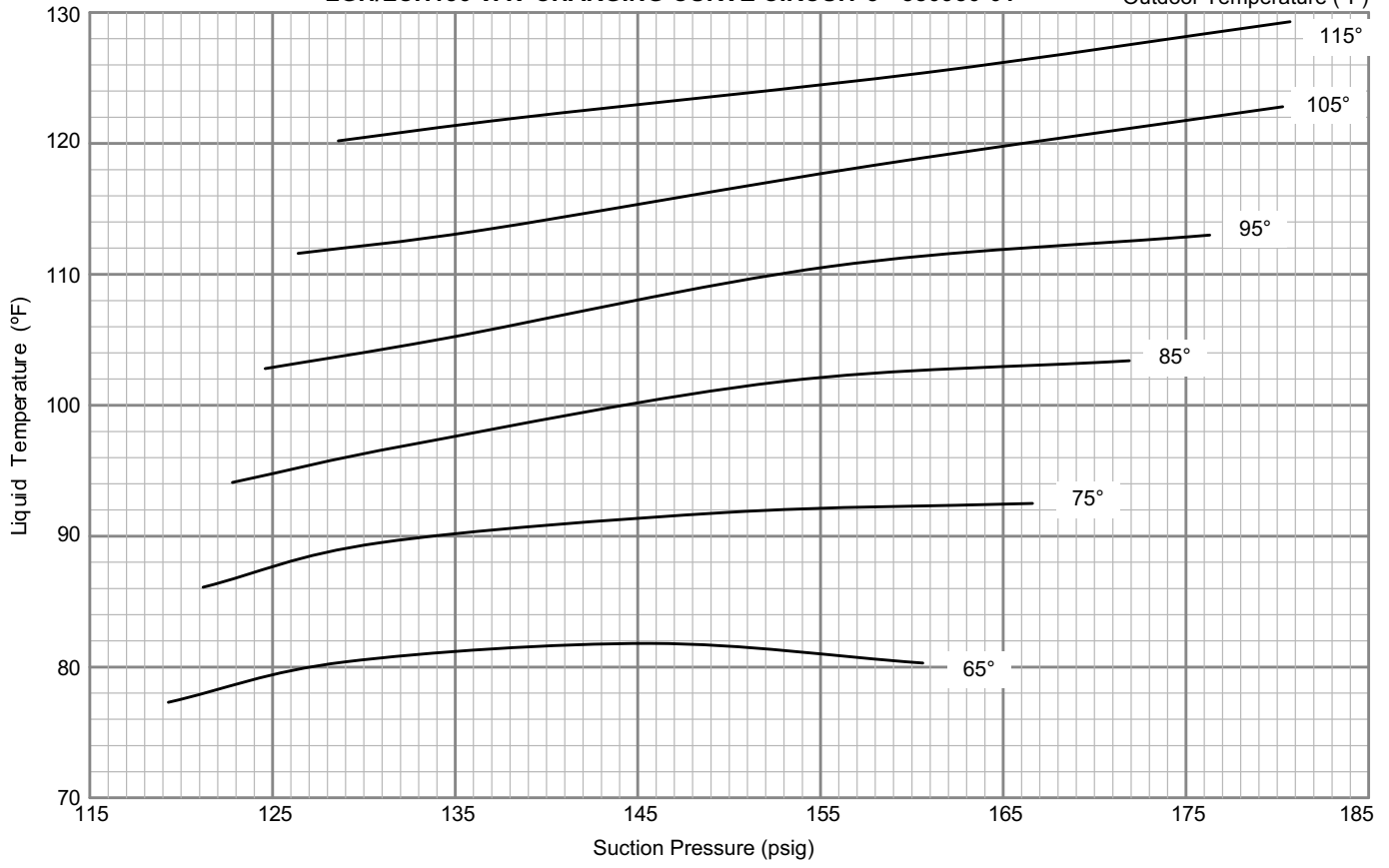

LGH/LCH180 CAV/STAGED CHARGING CURVES CIRCUIT 1

Outdoor Temperature (°F)

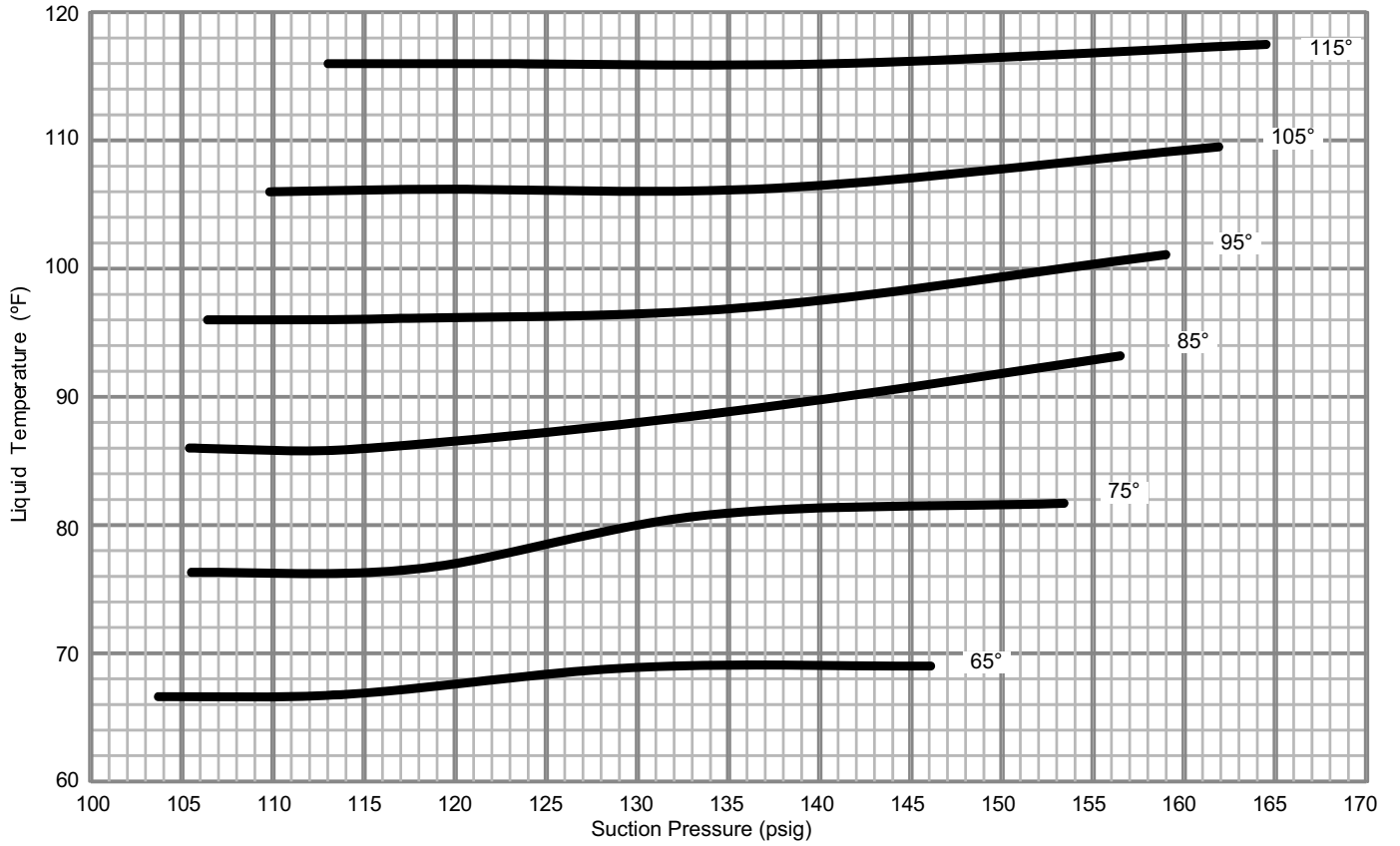

LGH/LCH180 CAV/STAGED CHARGING CURVES CIRCUIT 2

Outdoor Temperature (°F)

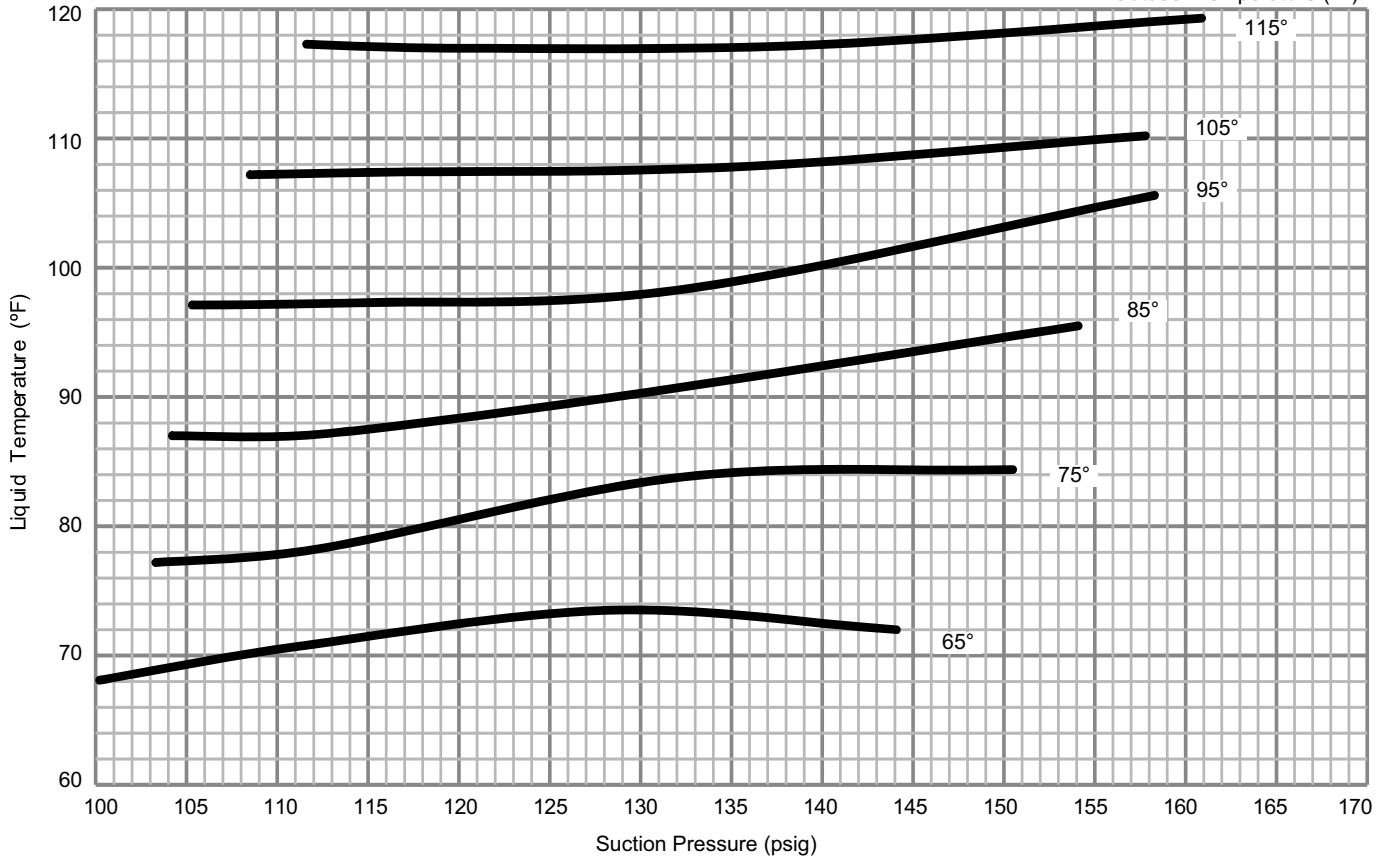

LGH/LCH180 CAV/STAGED CHARGING CURVES CIRCUIT 3

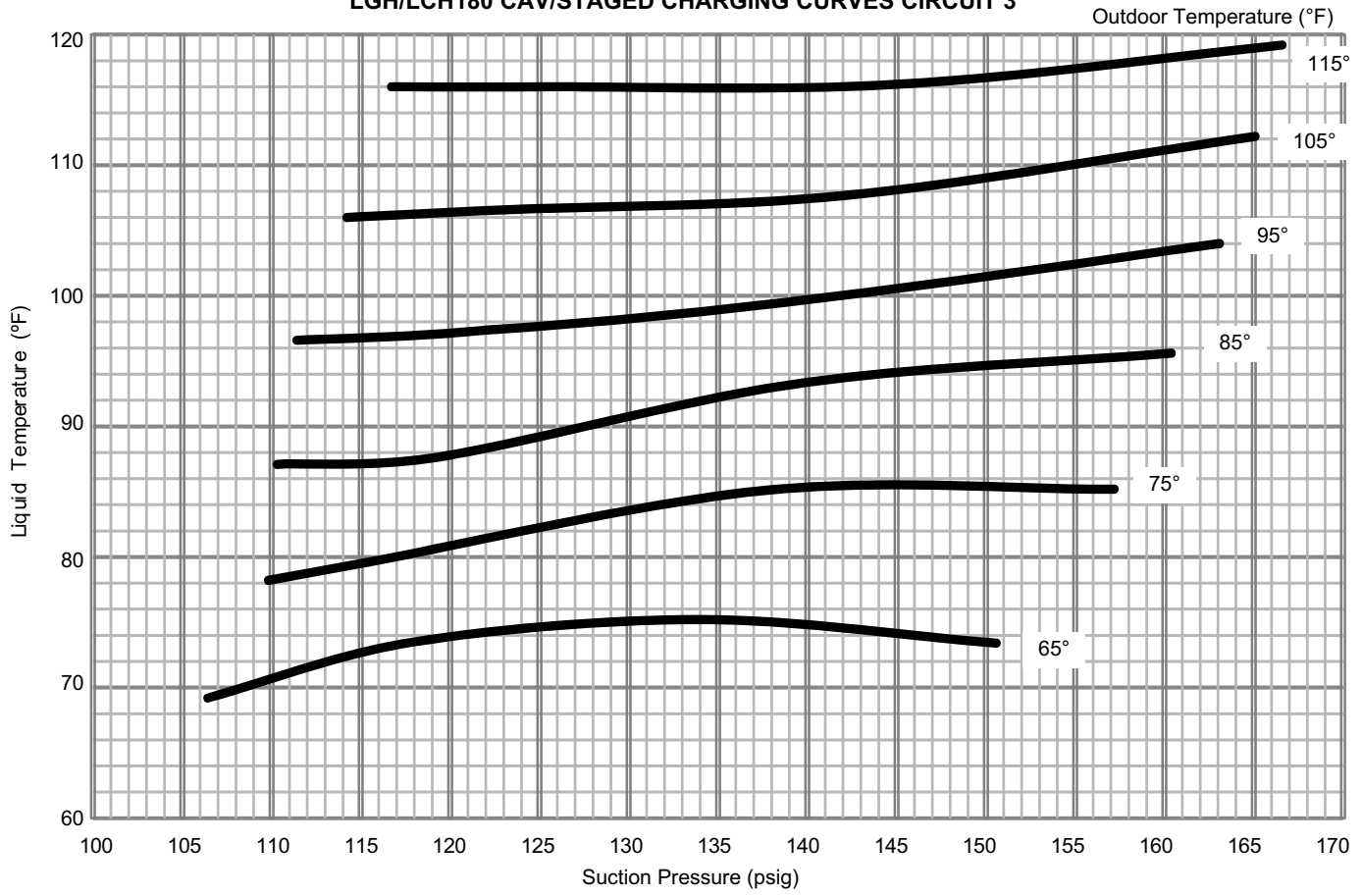

LGH/LCH180 CAV/STAGED REHEAT CHARGING CURVES CIRCUIT 1 Outdoor Temperature (°F)

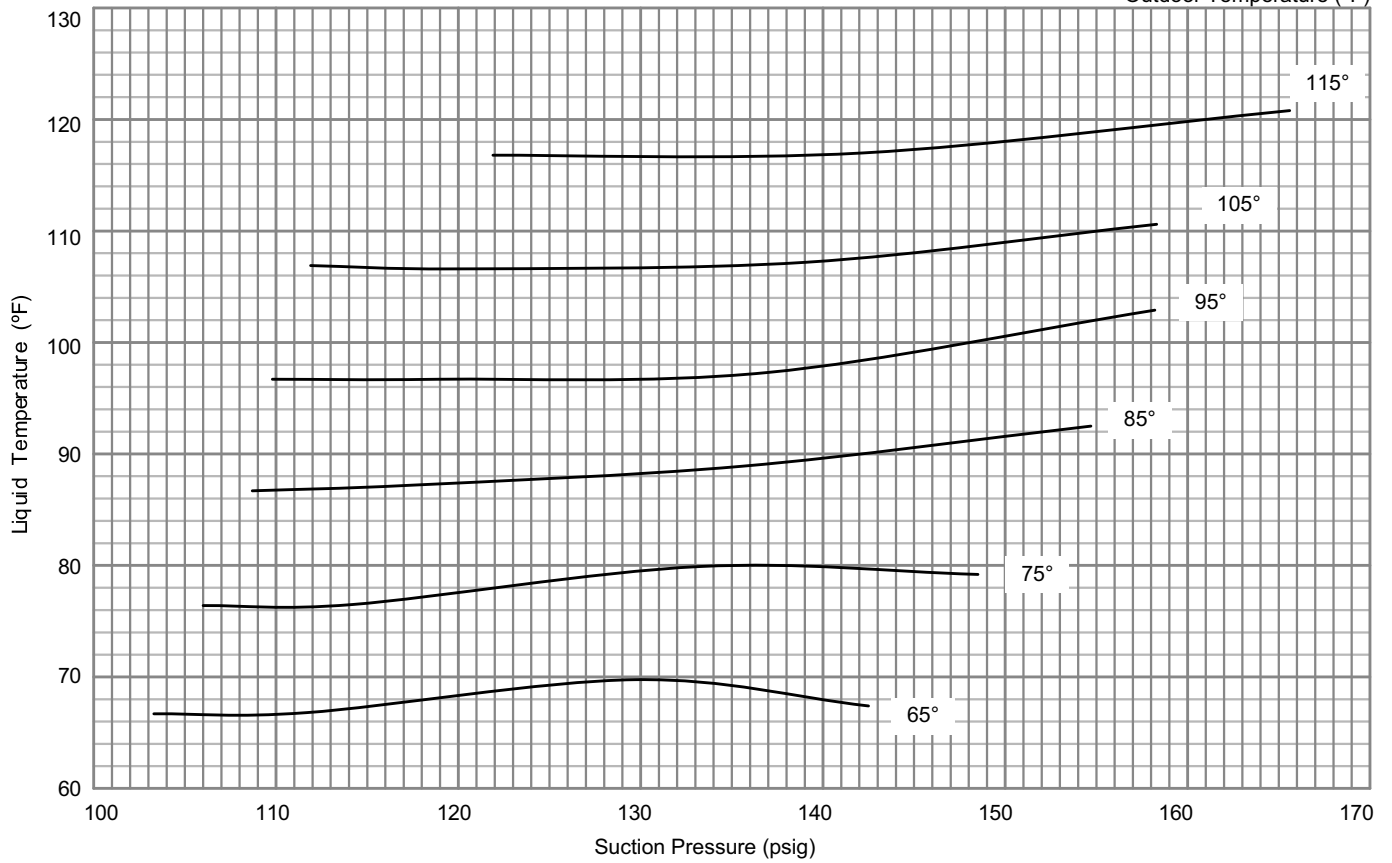

LGH/LCH180 CAV/STAGED REHEAT CHARGING CURVES CIRCUIT 2 Outdoor Temperature (°F)

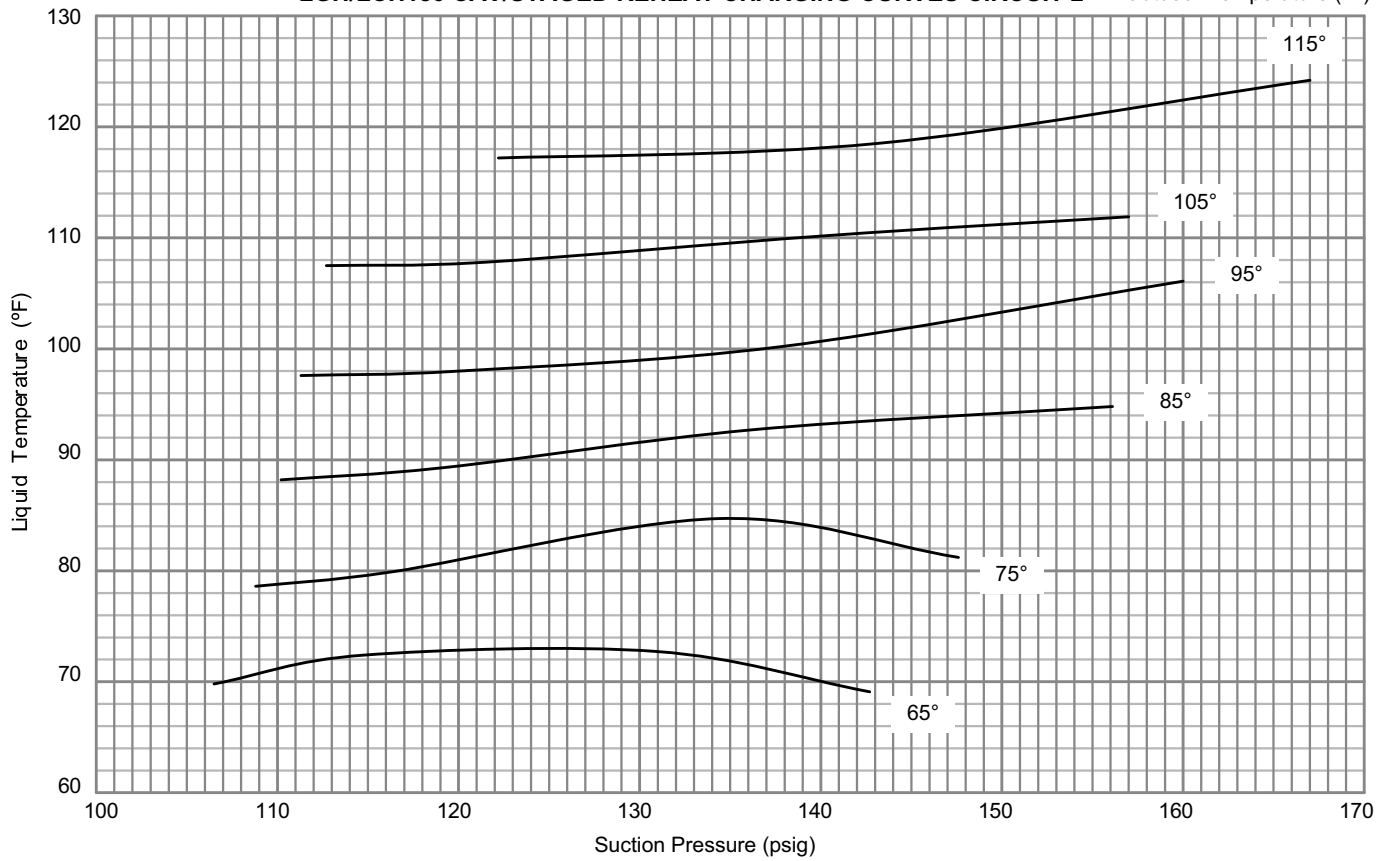

LGH/LCH180 CAV/STAGED REHEAT CHARGING CURVES CIRCUIT 3 Outdoor Temperature (°F)

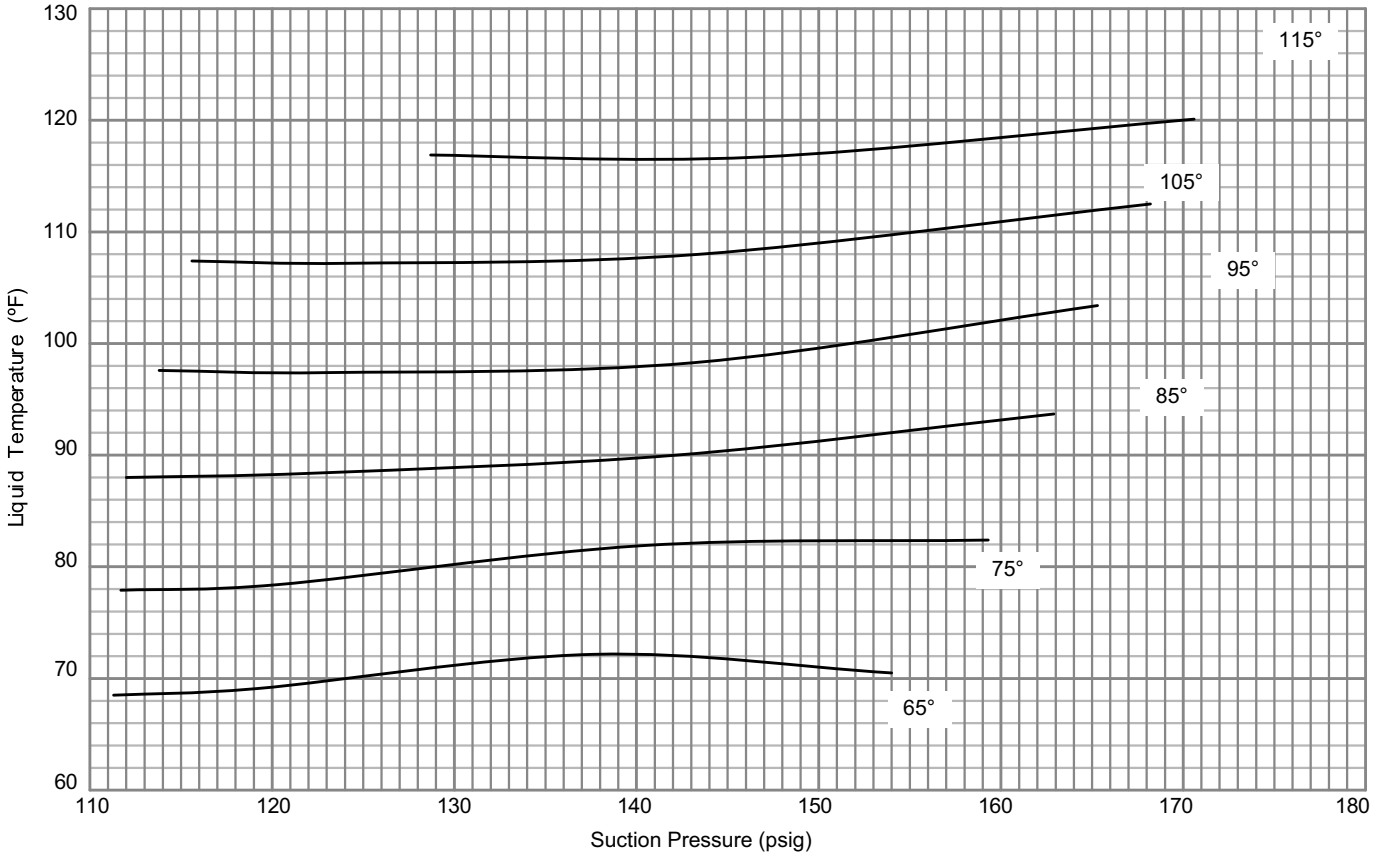

LGH/LCH180 VAV CHARGING CURVES CIRCUIT 1 Outdoor Temperature (°F)

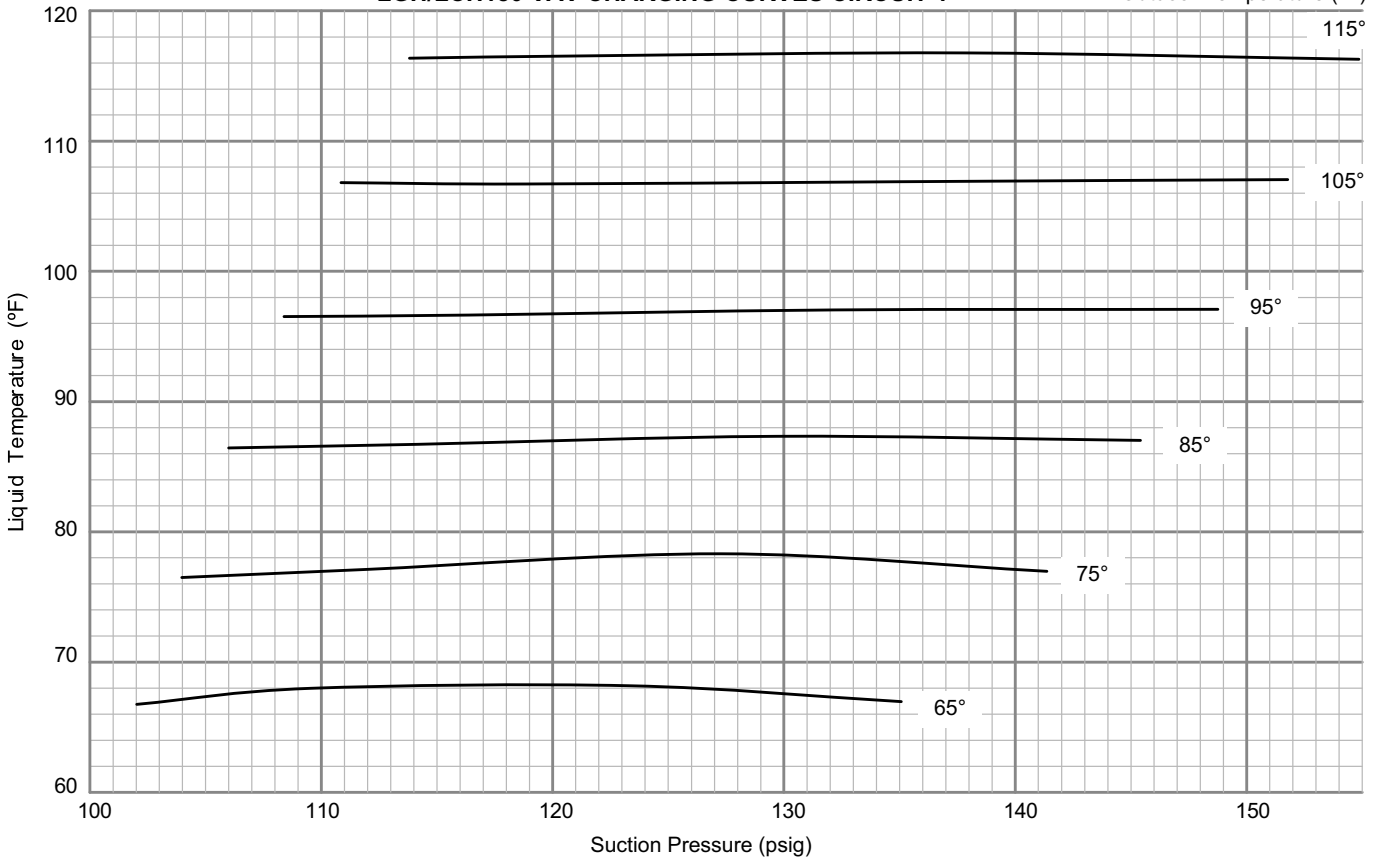

LGH/LCH180 VAV CHARGING CURVES CIRCUIT 2

Outdoor Temperature (°F)

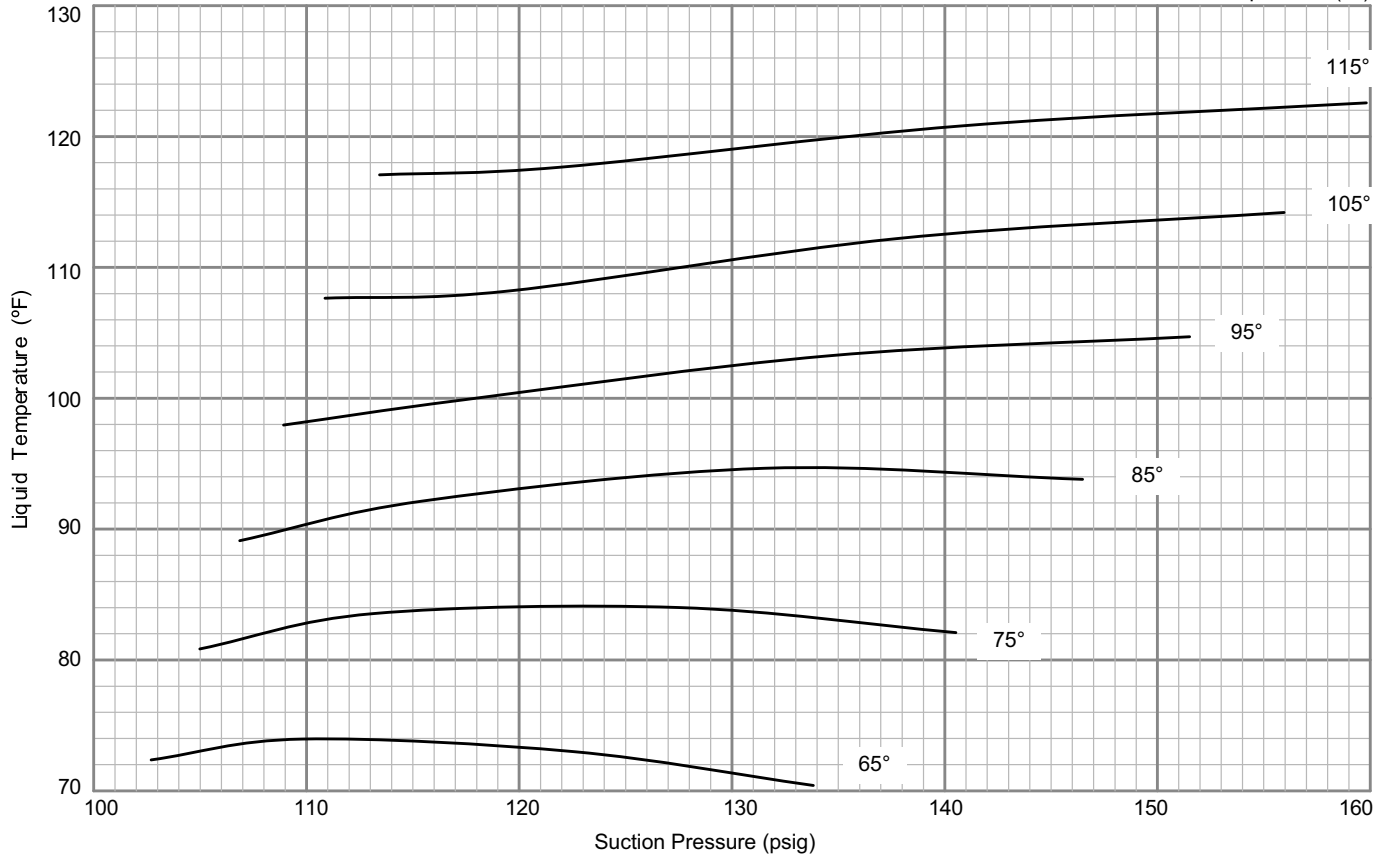

LGH/LCH180 VAV CHARGING CURVES CIRCUIT 3

Outdoor Temperature (°F)

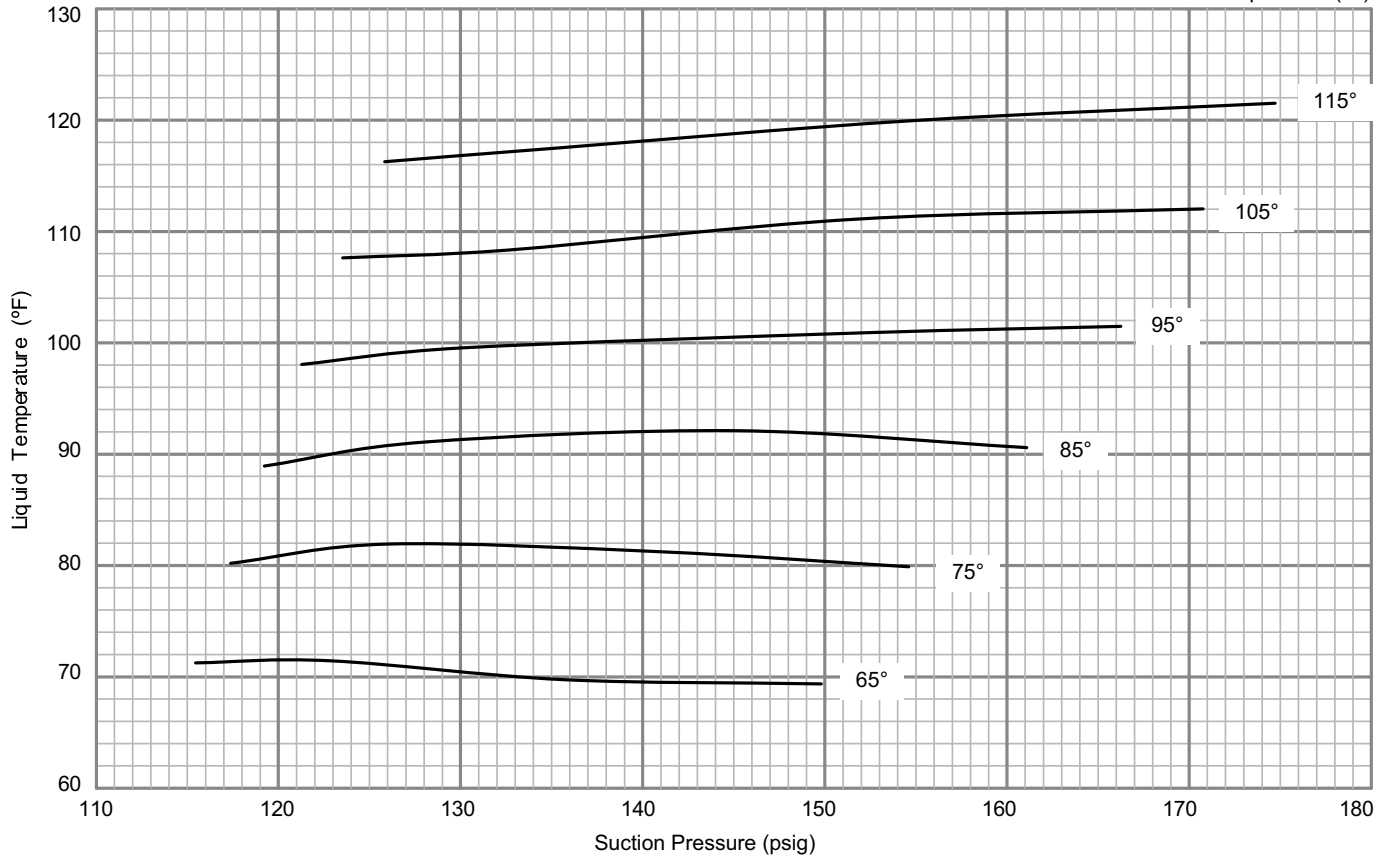

LGH/LCH210 CHARGING CURVE CIRCUIT 1

Outdoor Temperature (°F)

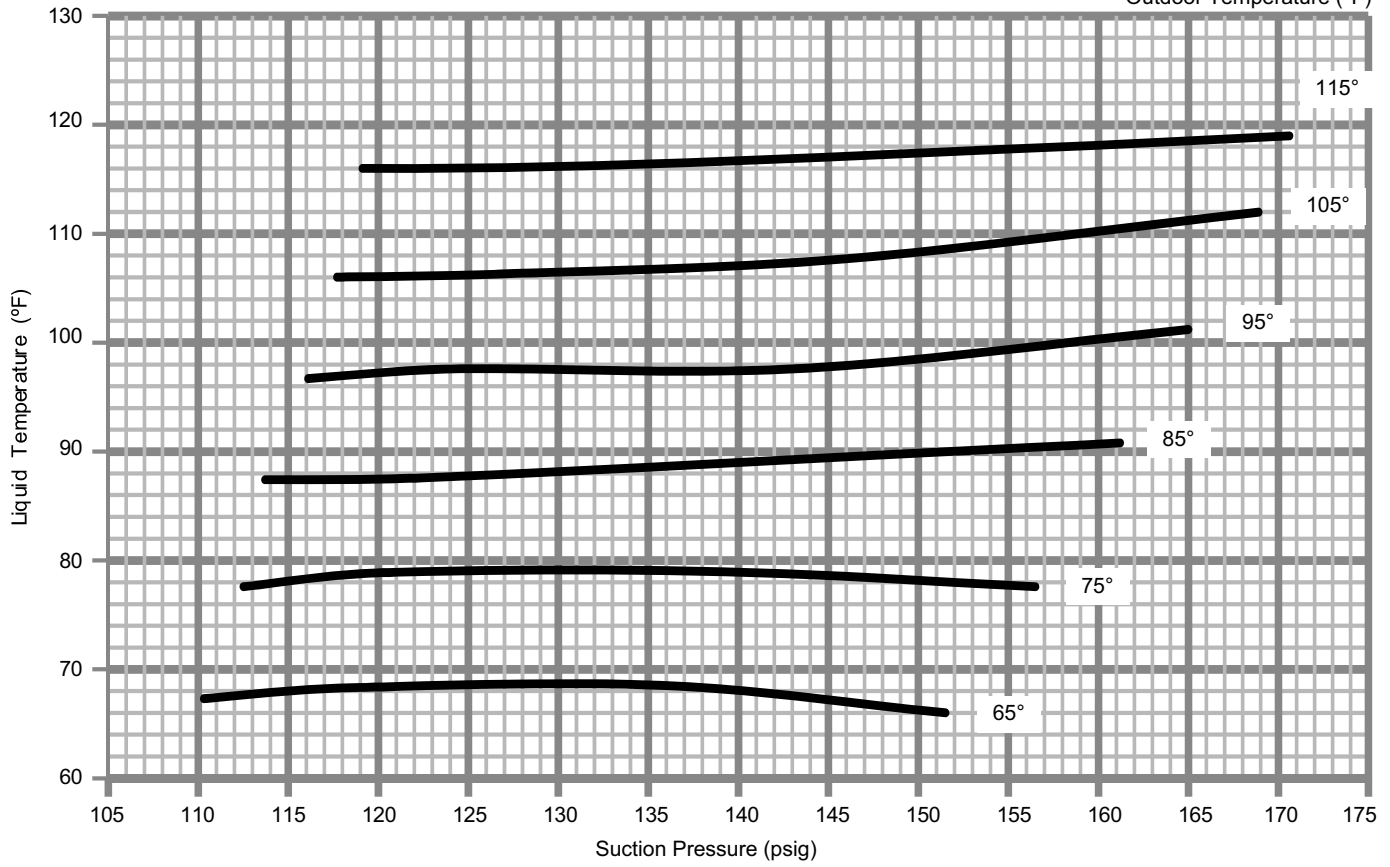

LGH/LCH210 CHARGING CURVE CIRCUIT 2

Outdoor Temperature (°F)

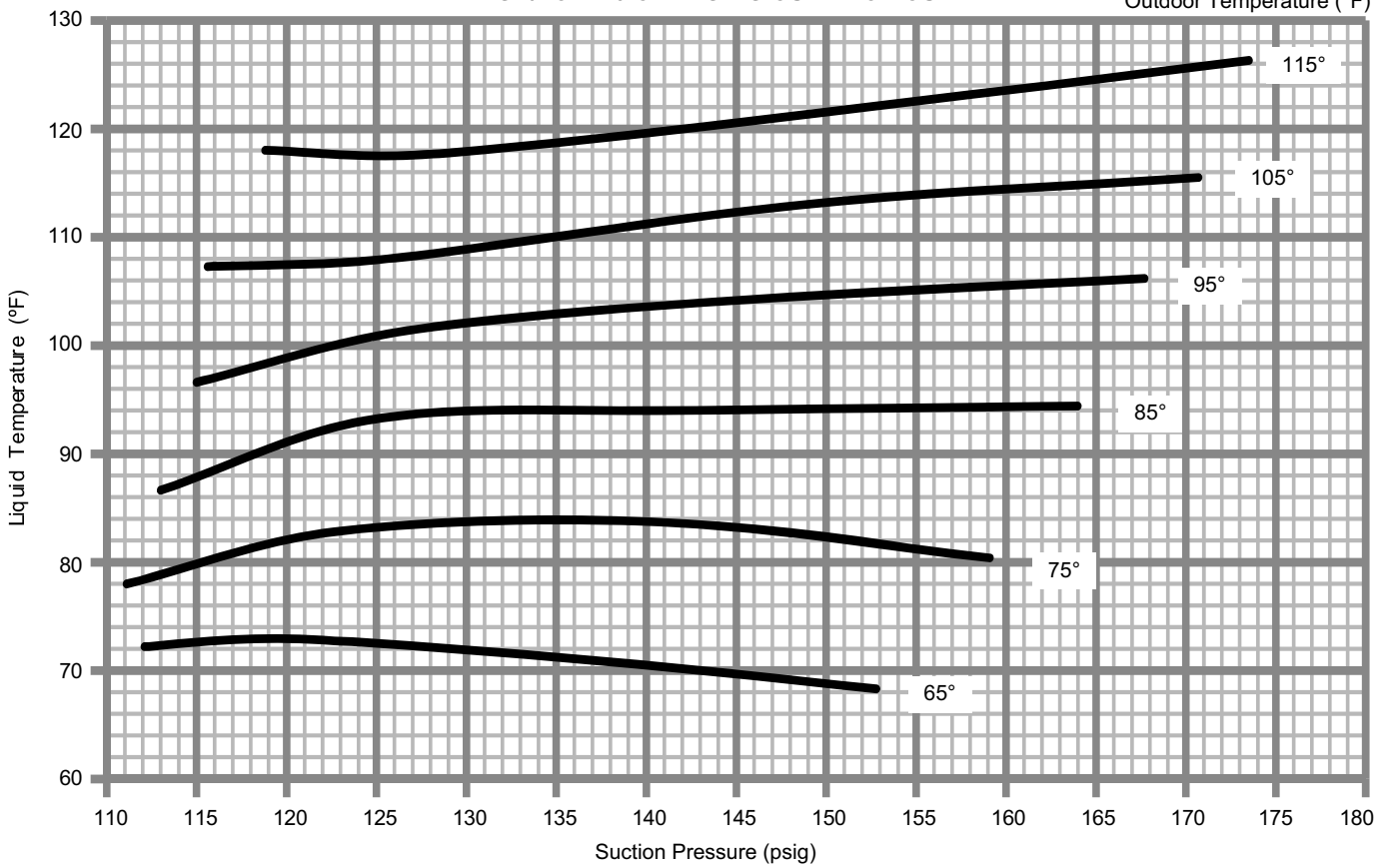

LGH/LCH210 CHARGING CURVE CIRCUIT 3

Outdoor Temperature (°F)

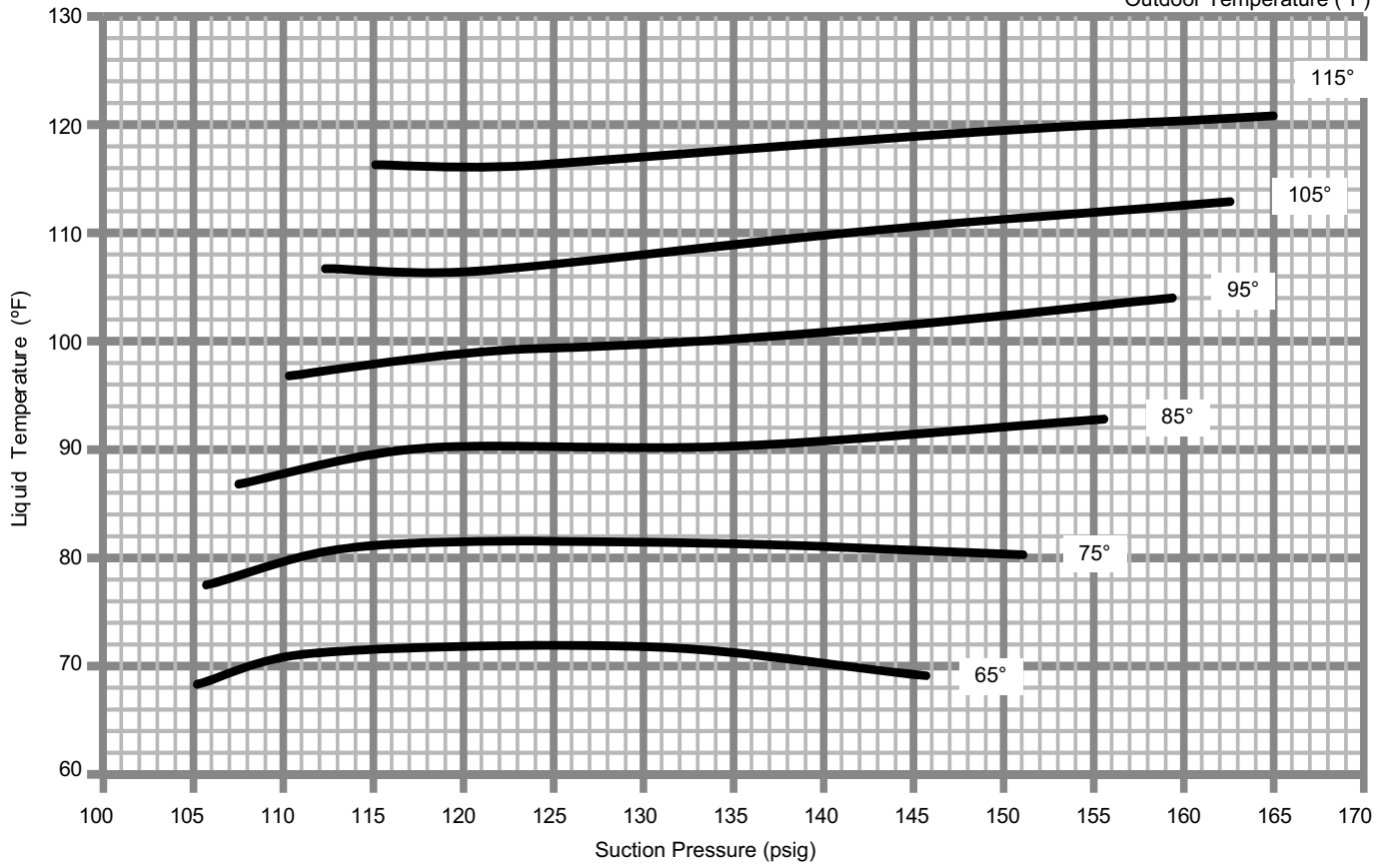

LGH/LCH210 REHEAT CHARGING CURVES CIRCUIT 1

Outdoor Temperature (°F)

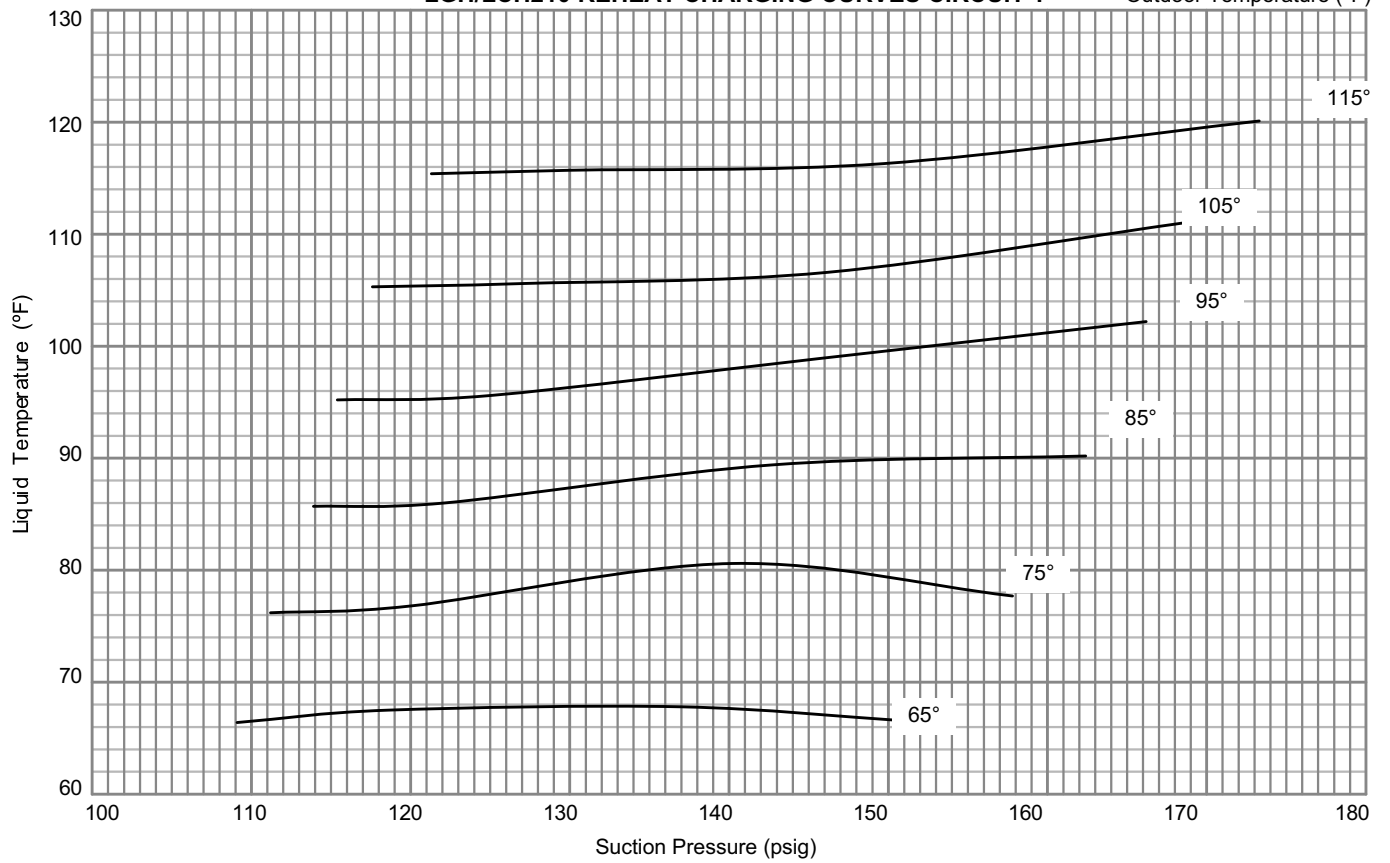

LGH/LCH210 REHEAT CHARGING CURVES CIRCUIT 2

Outdoor Temperature (°F)

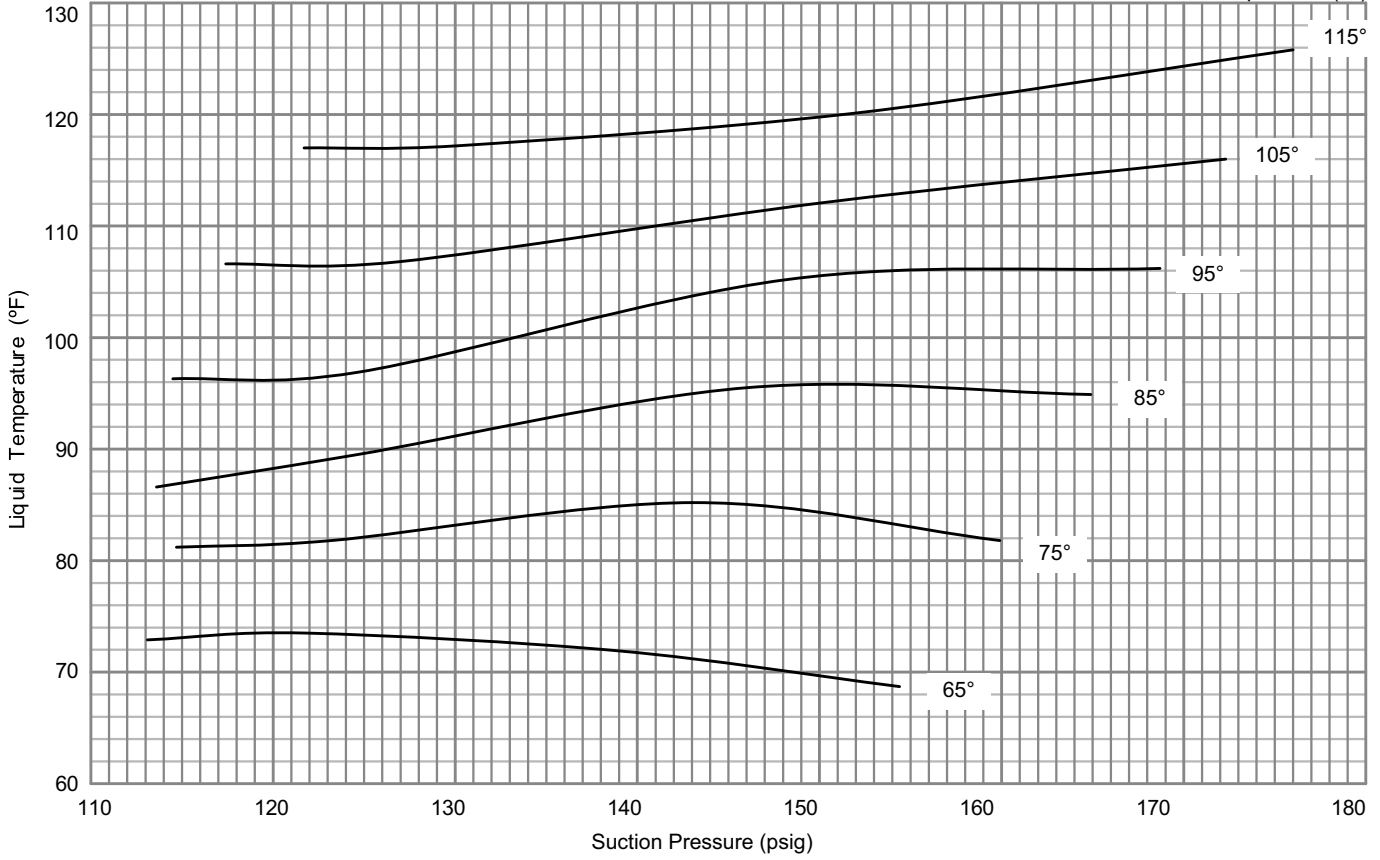

LGH/LCH210 REHEAT CHARGING CURVES CIRCUIT 3

Outdoor Temperature (°F)

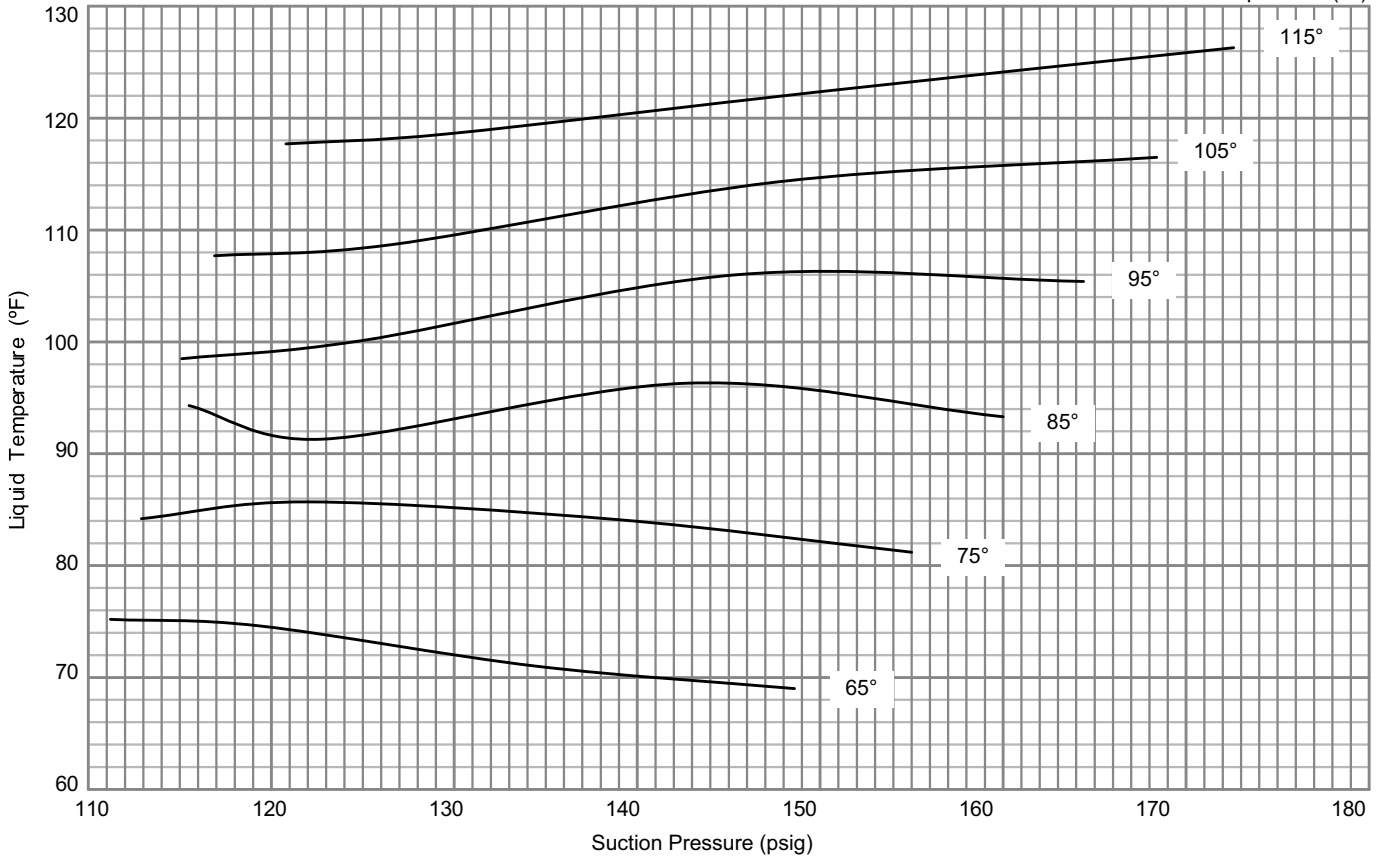

LGH/LCH240 CAV/STAGED CHARGING CURVES CIRCUIT 1

Outdoor Temperature (°F)

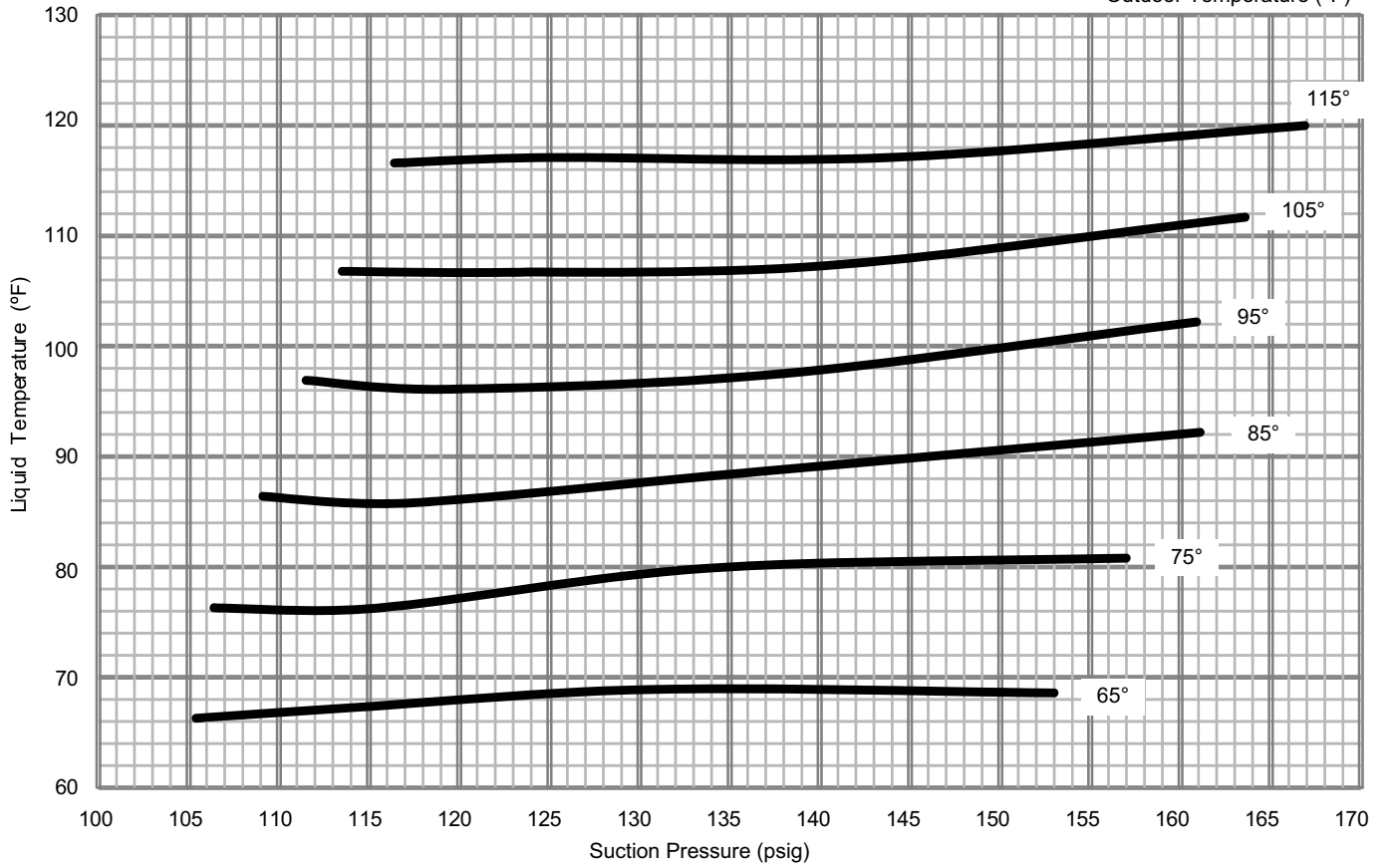

LGH/LCH240 CAV/STAGED CHARGING CURVES CIRCUIT 2

Outdoor Temperature (°F)

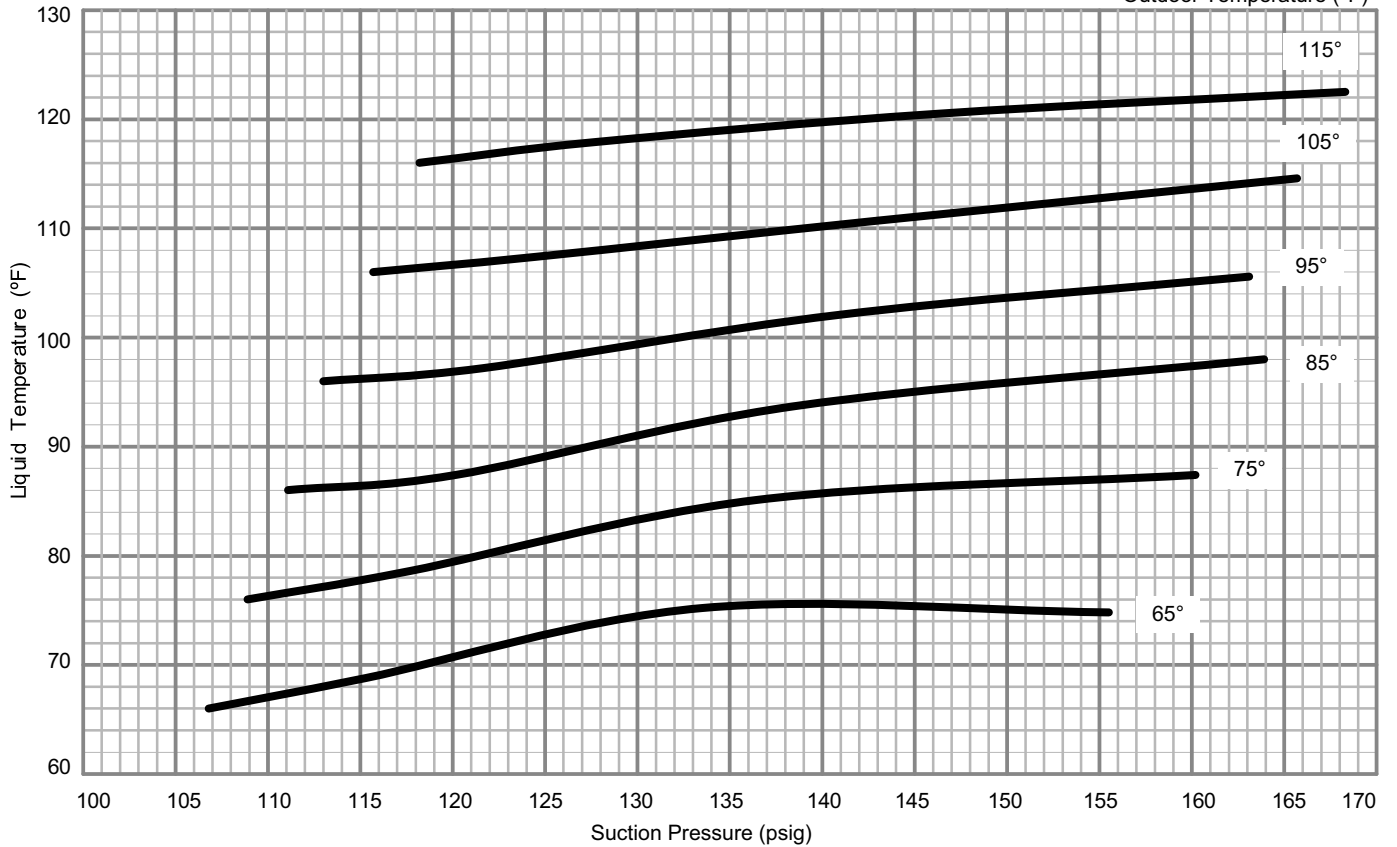

LGH/LCH240 CAV/STAGED CHARGING CURVES CIRCUIT 3

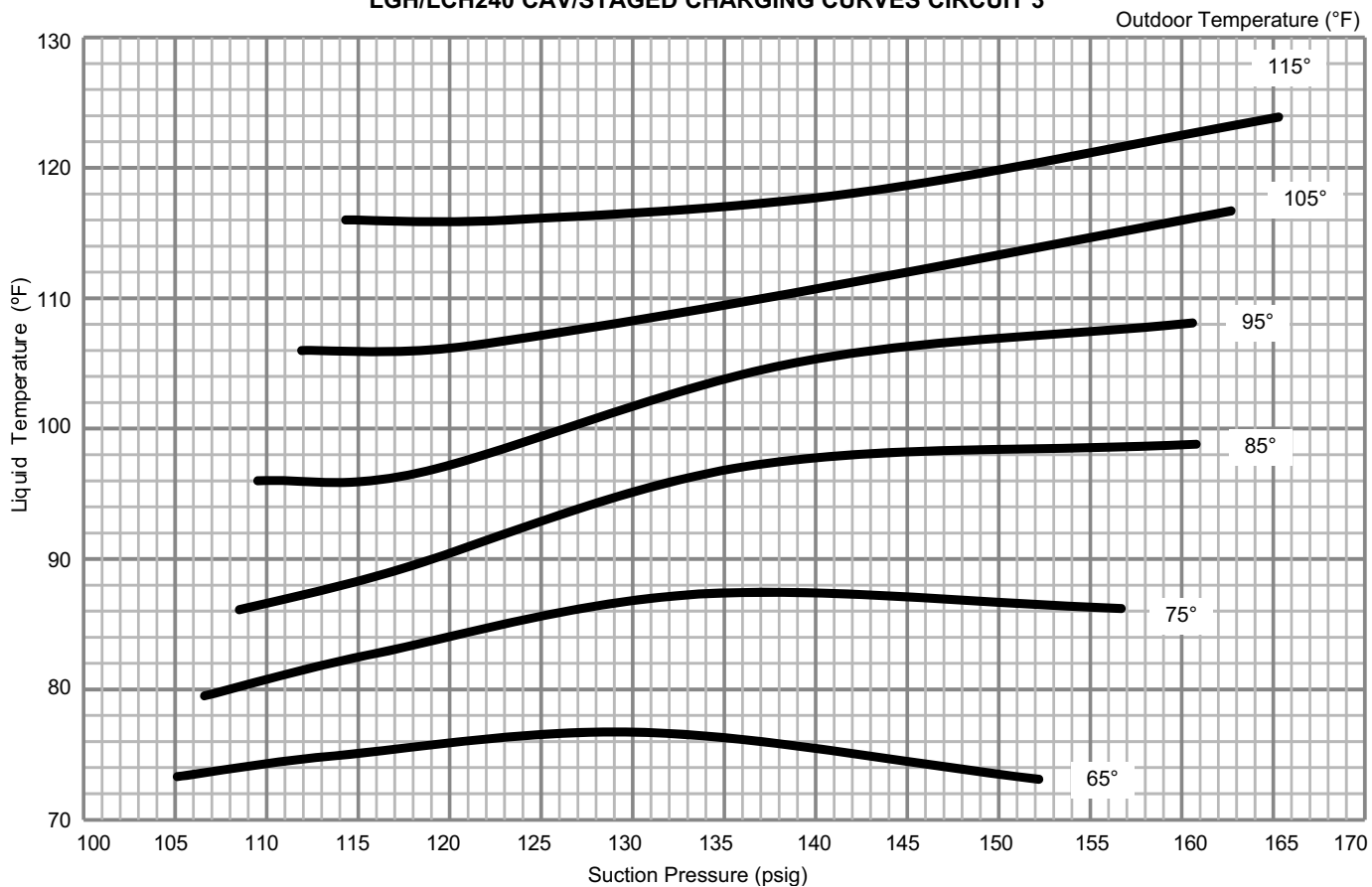

LGH/LCH240 CAV/STAGED CHARGING CURVES CIRCUIT 4

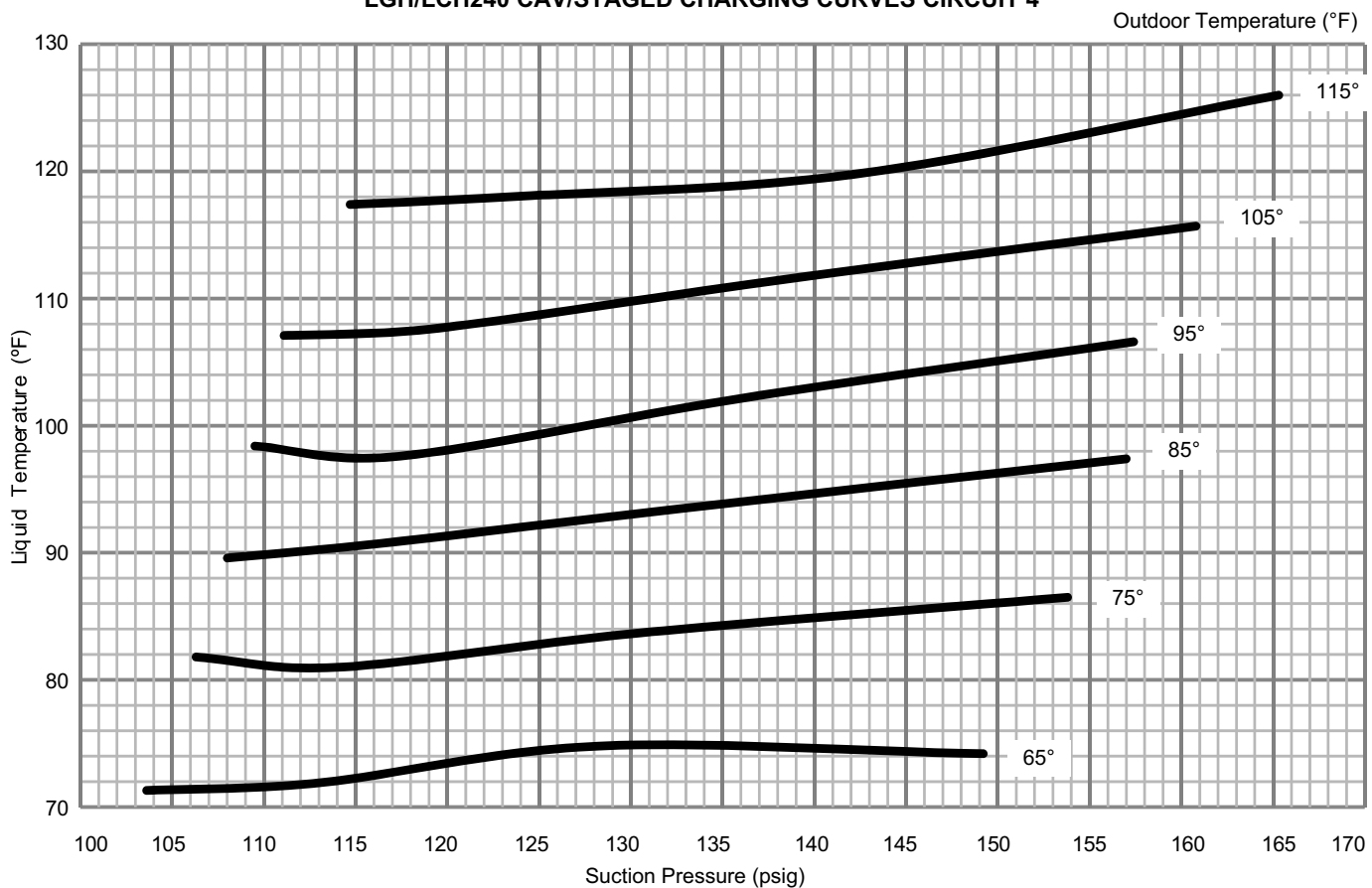

LGH/LCH240 CAV/STAGED REHEAT CHARGING CURVES CIRCUIT 1

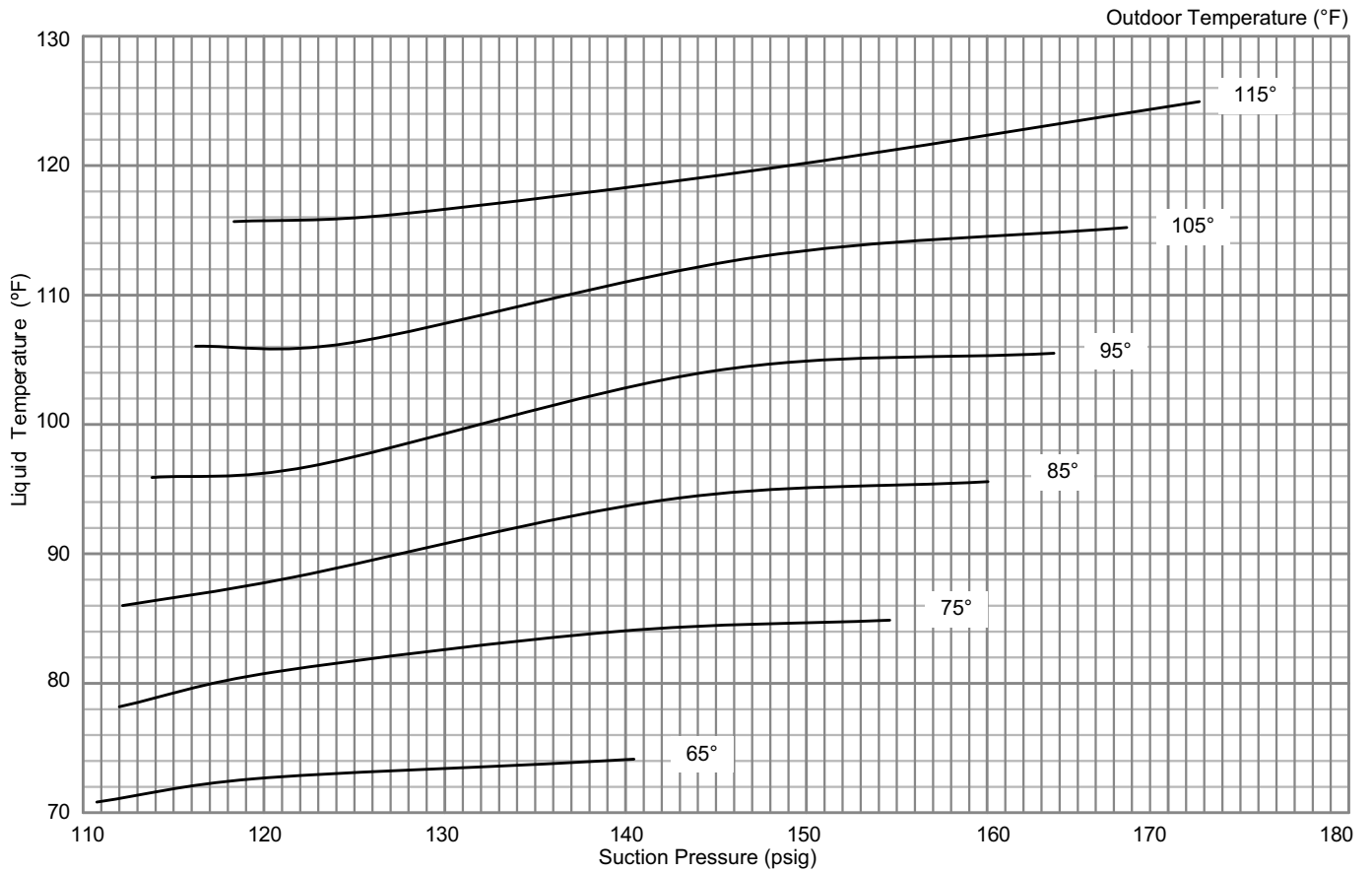

LGH/LCH240 CAV/STAGED REHEAT CHARGING CURVES CIRCUIT 2

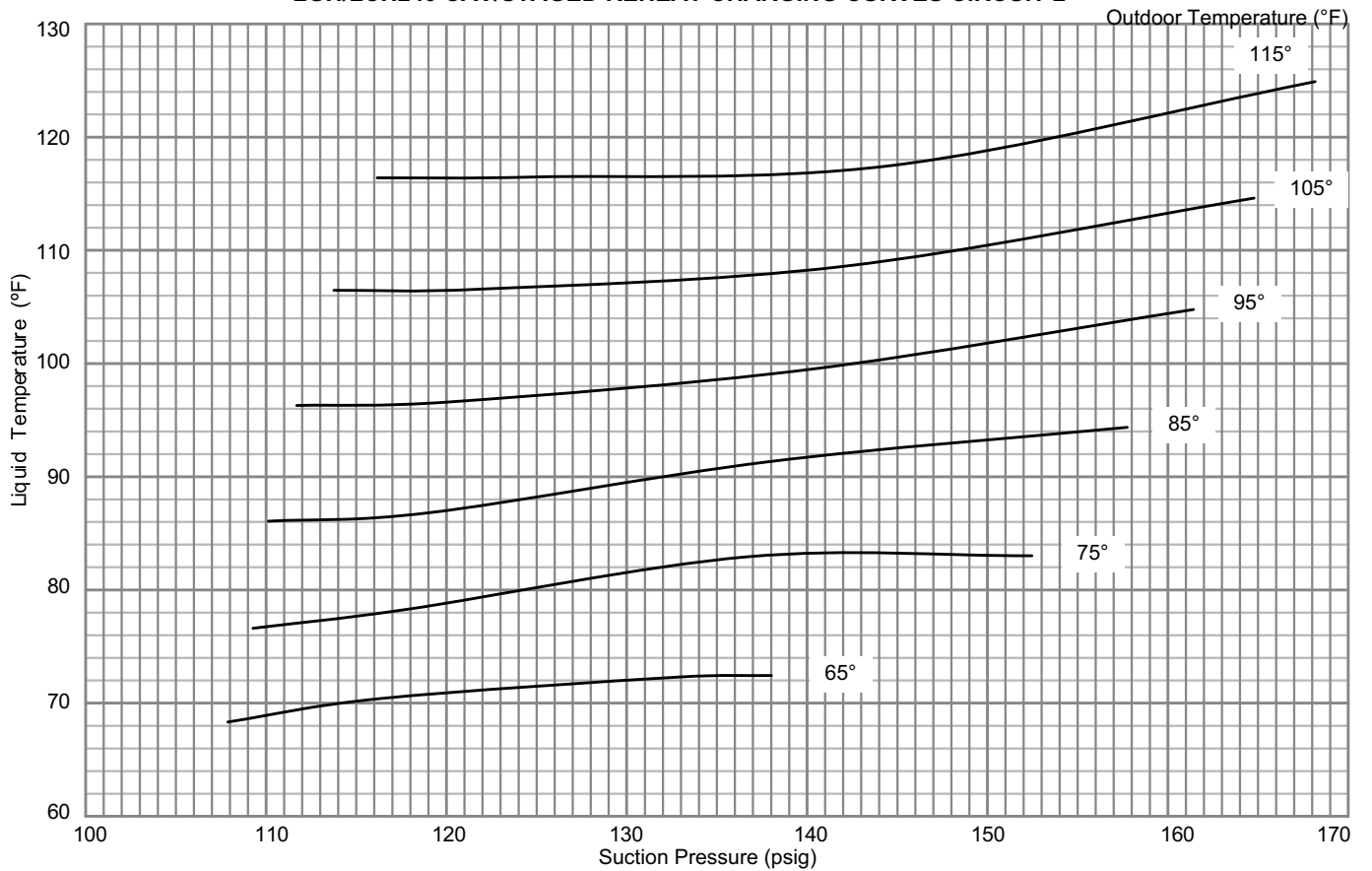

LGH/LCH240 CAV/STAGED REHEAT CHARGING CURVES CIRCUIT 3

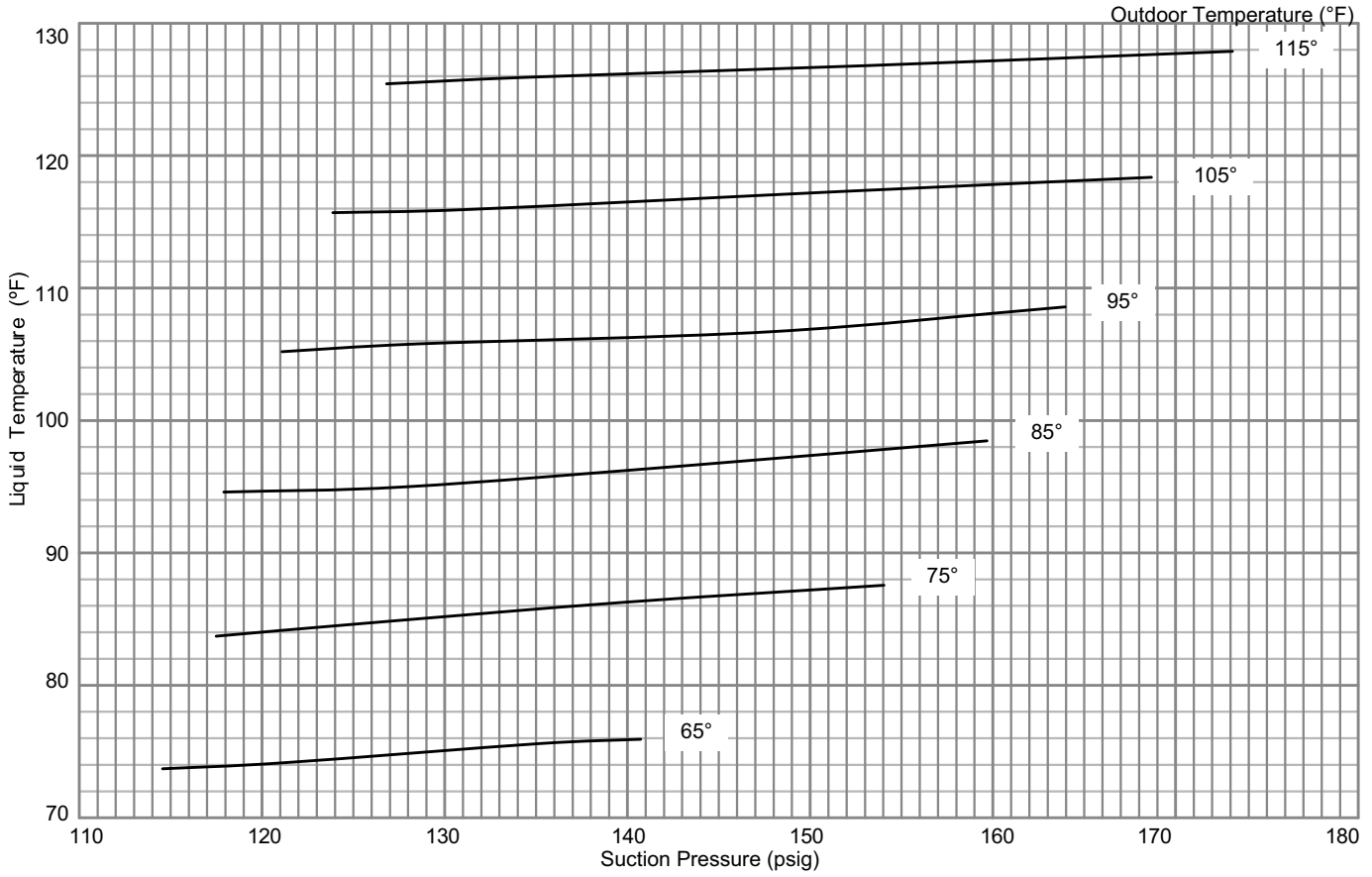

LGH/LCH240 CAV/STAGED REHEAT CHARGING CURVES CIRCUIT 4

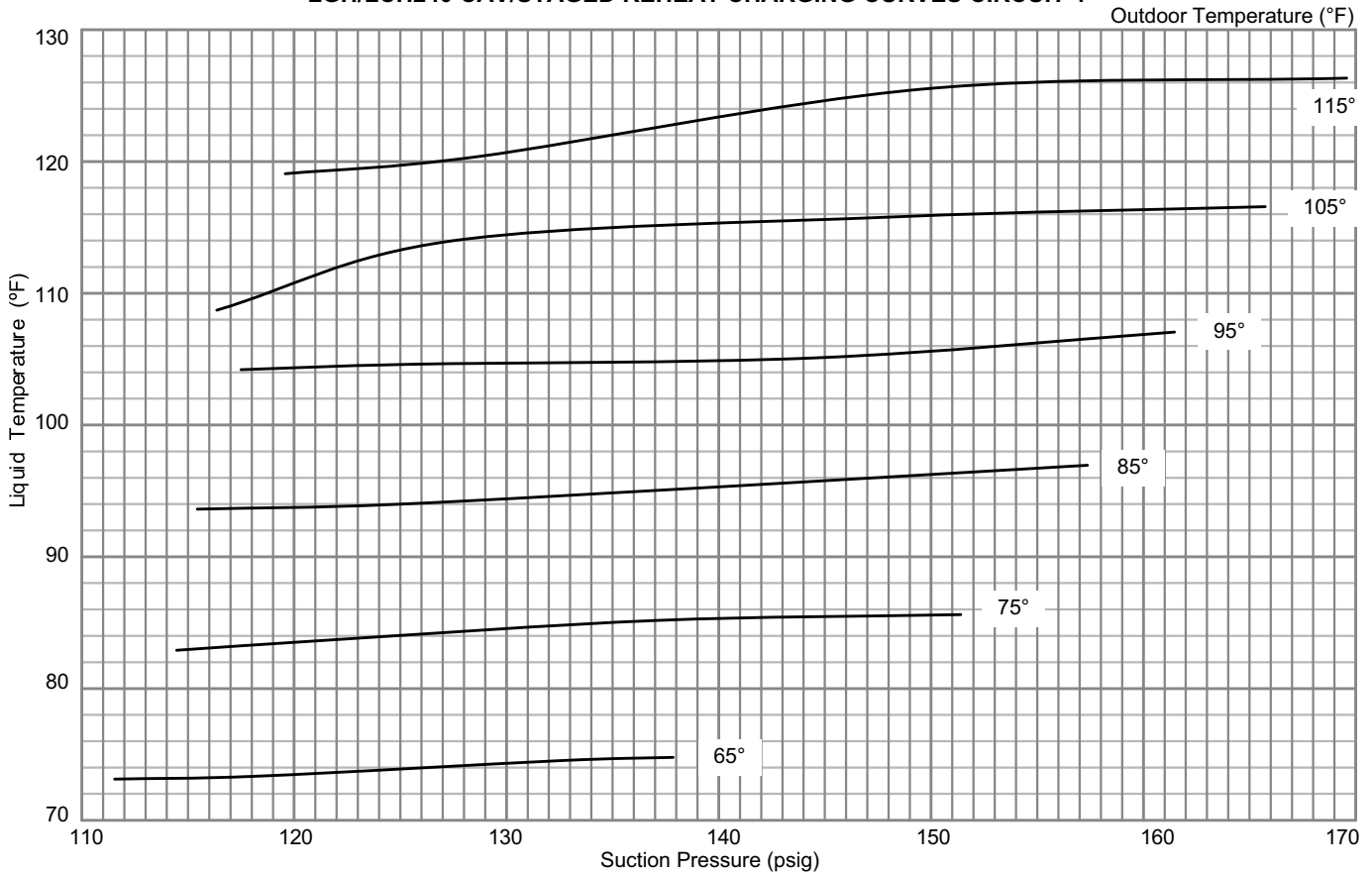

LGH/LCH240 VAV CHARGING CURVES CIRCUIT 1

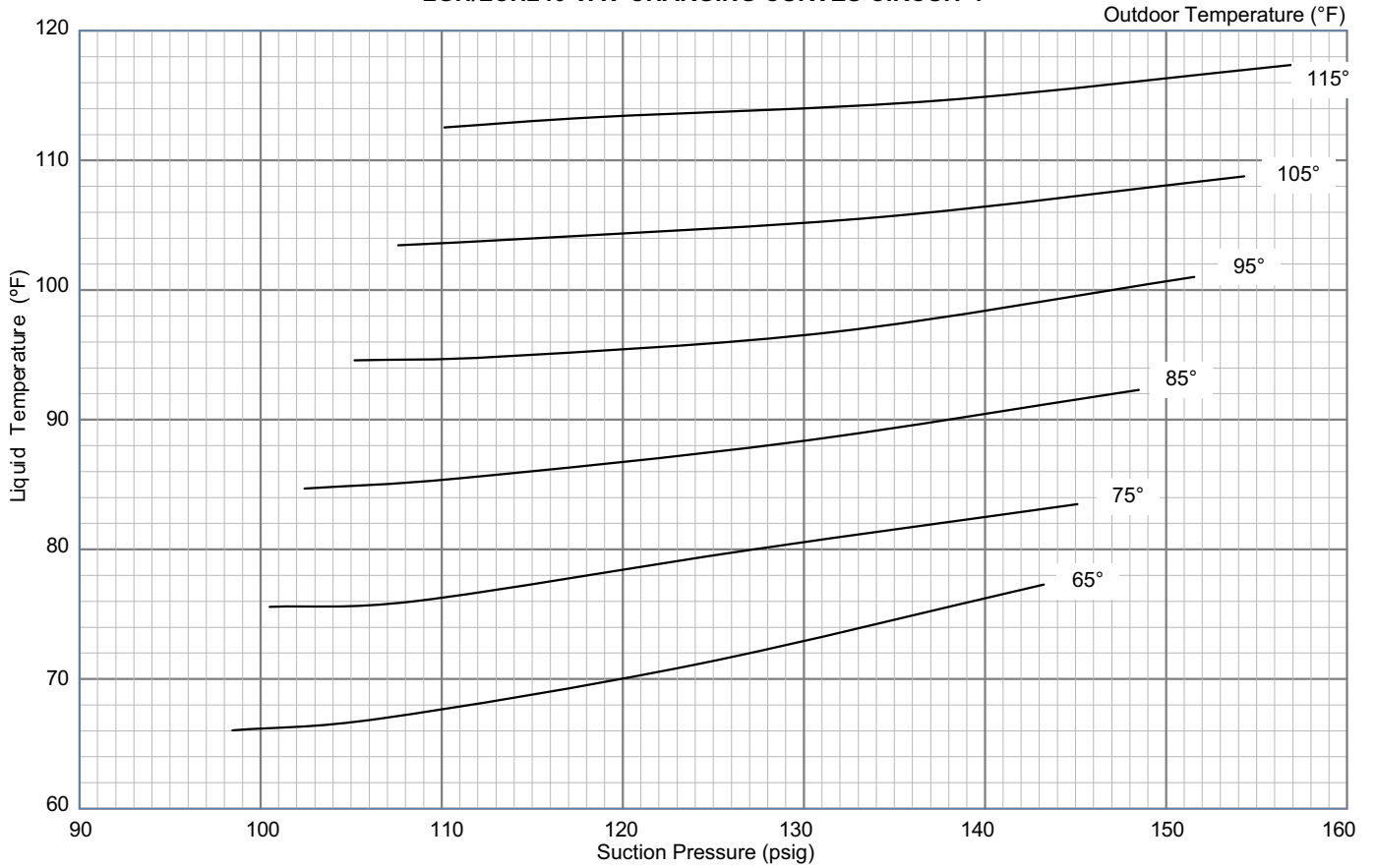

LGH/LCH240 VAV CHARGING CURVES CIRCUIT 2

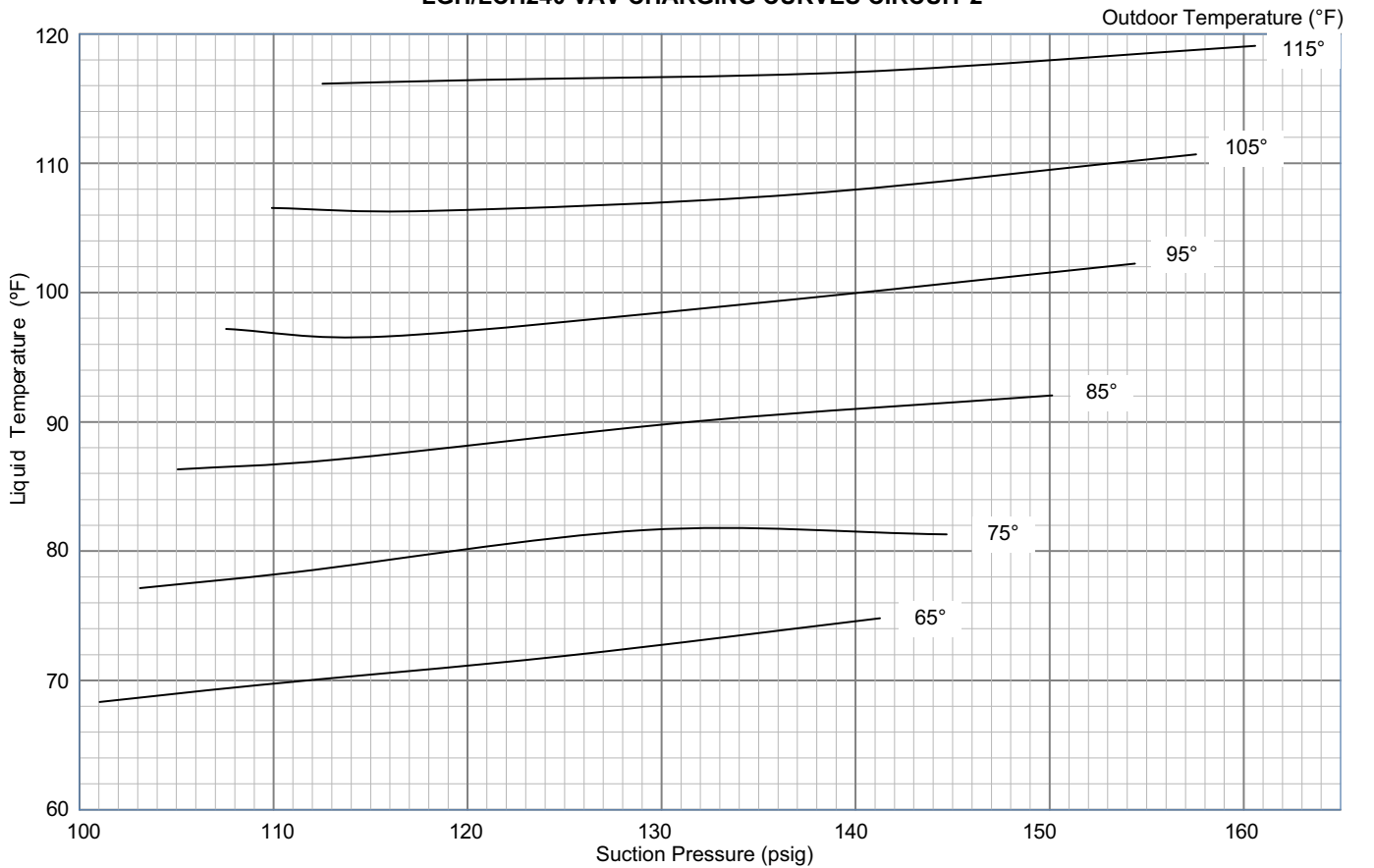

LGH/LCH240 VAV CHARGING CURVES CIRCUIT 3

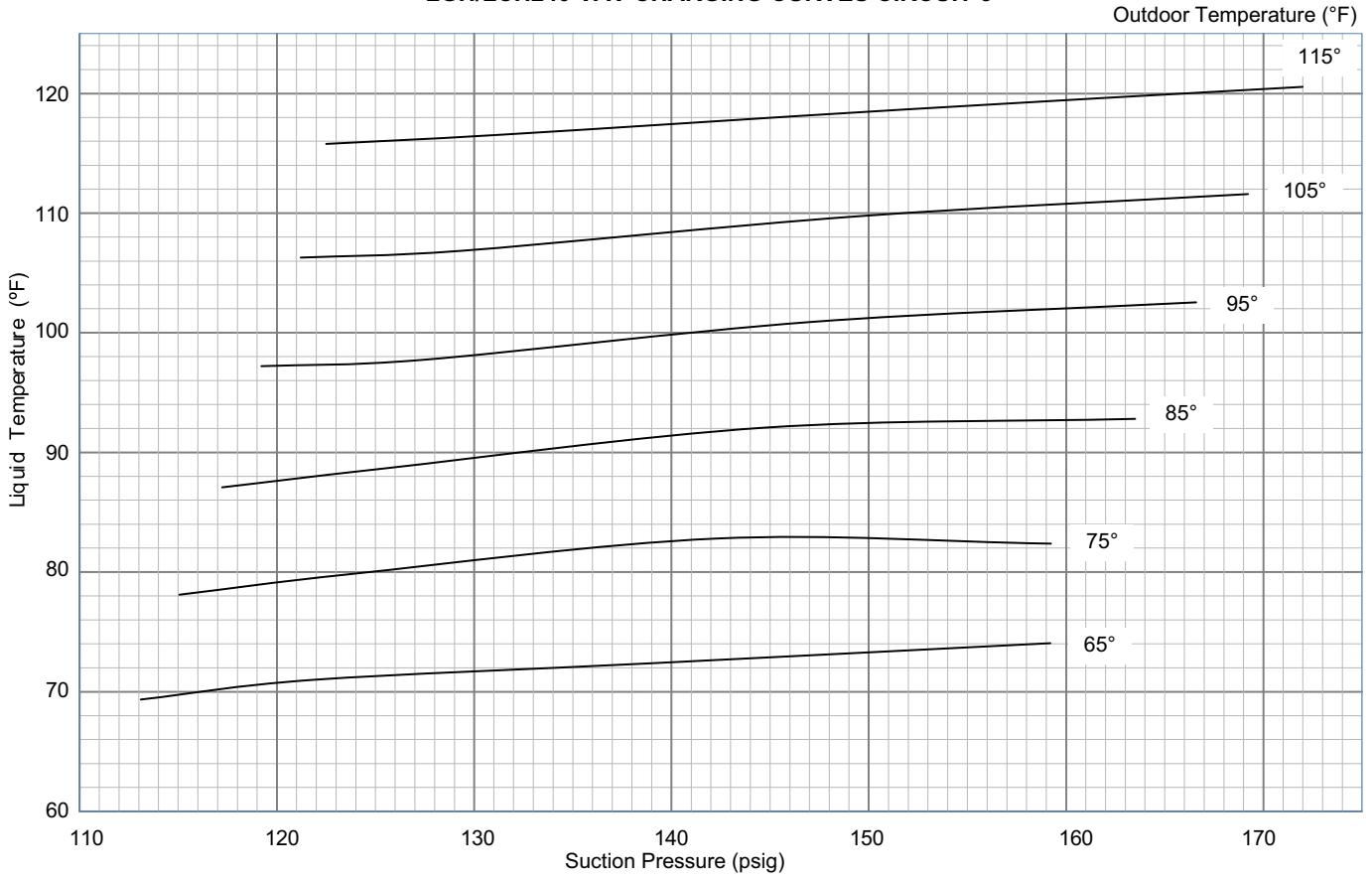

LGH/LCH240 VAV CHARGING CURVES CIRCUIT 4

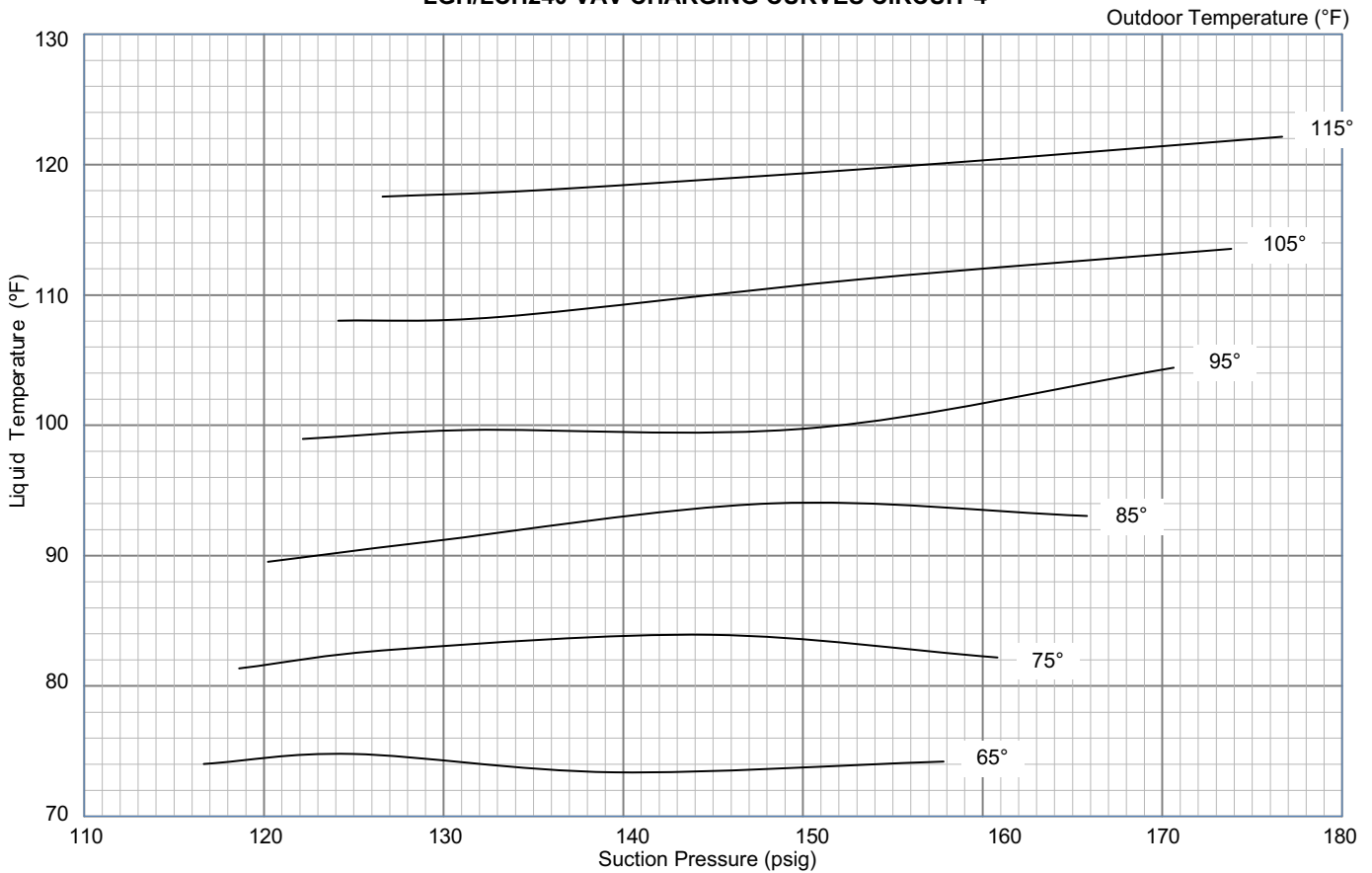

LGH/LCH300S CHARGING CURVE CIRCUIT 1

Outdoor Temperature (°F)

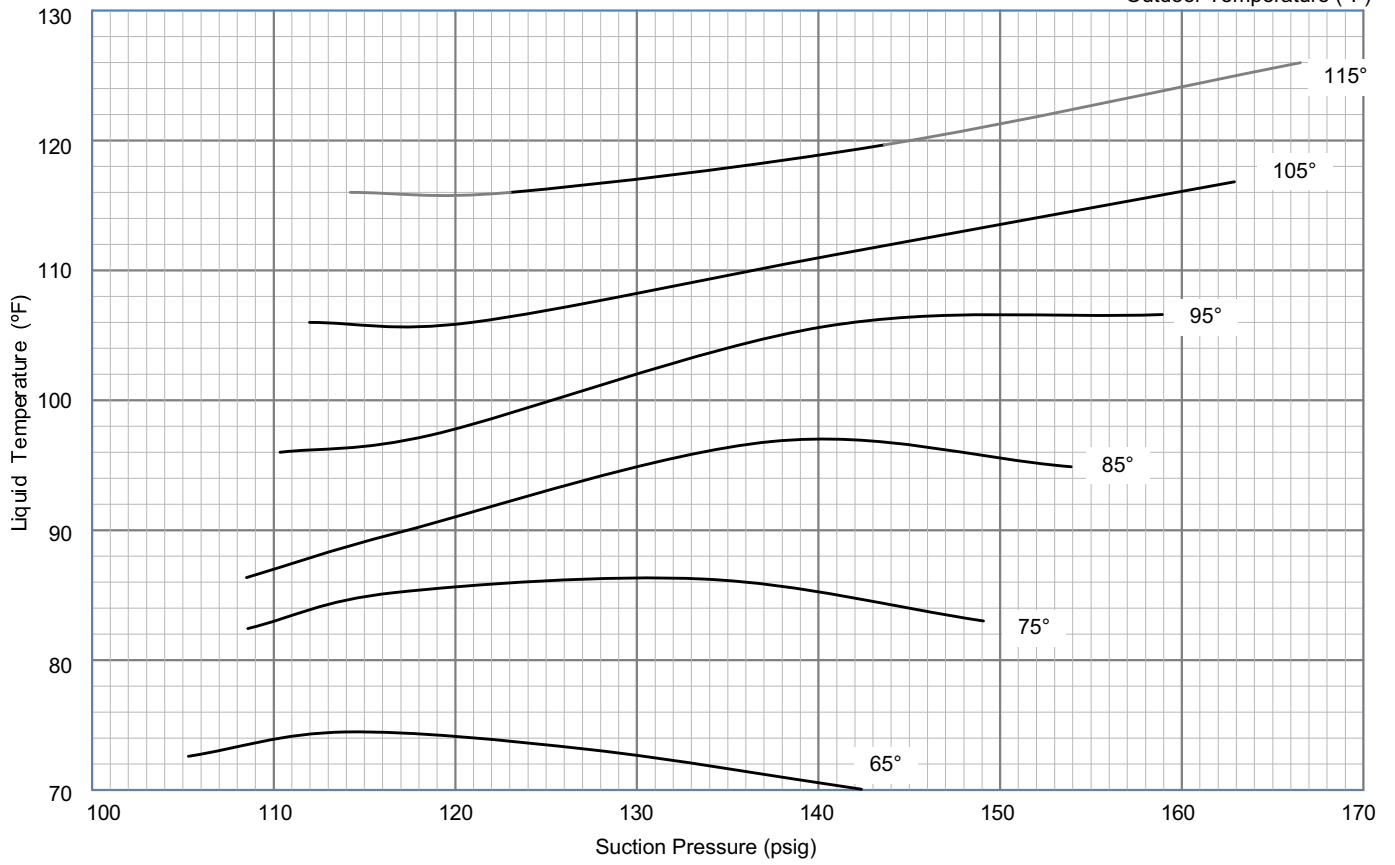

LGH/LCH300S CHARGING CURVE CIRCUIT 2

Outdoor Temperature (°F)

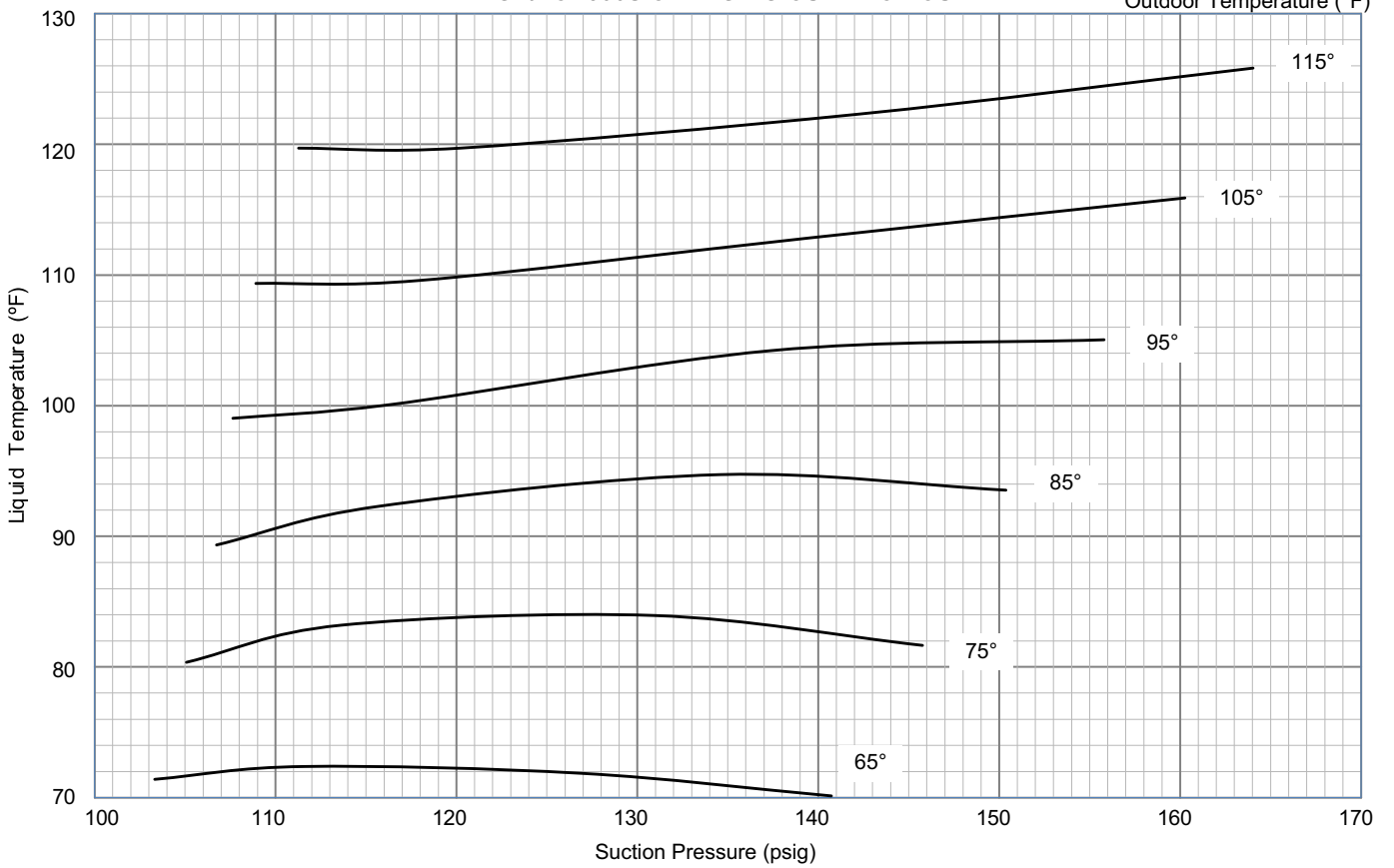

LGH/LCH300S CHARGING CURVE CIRCUIT 3

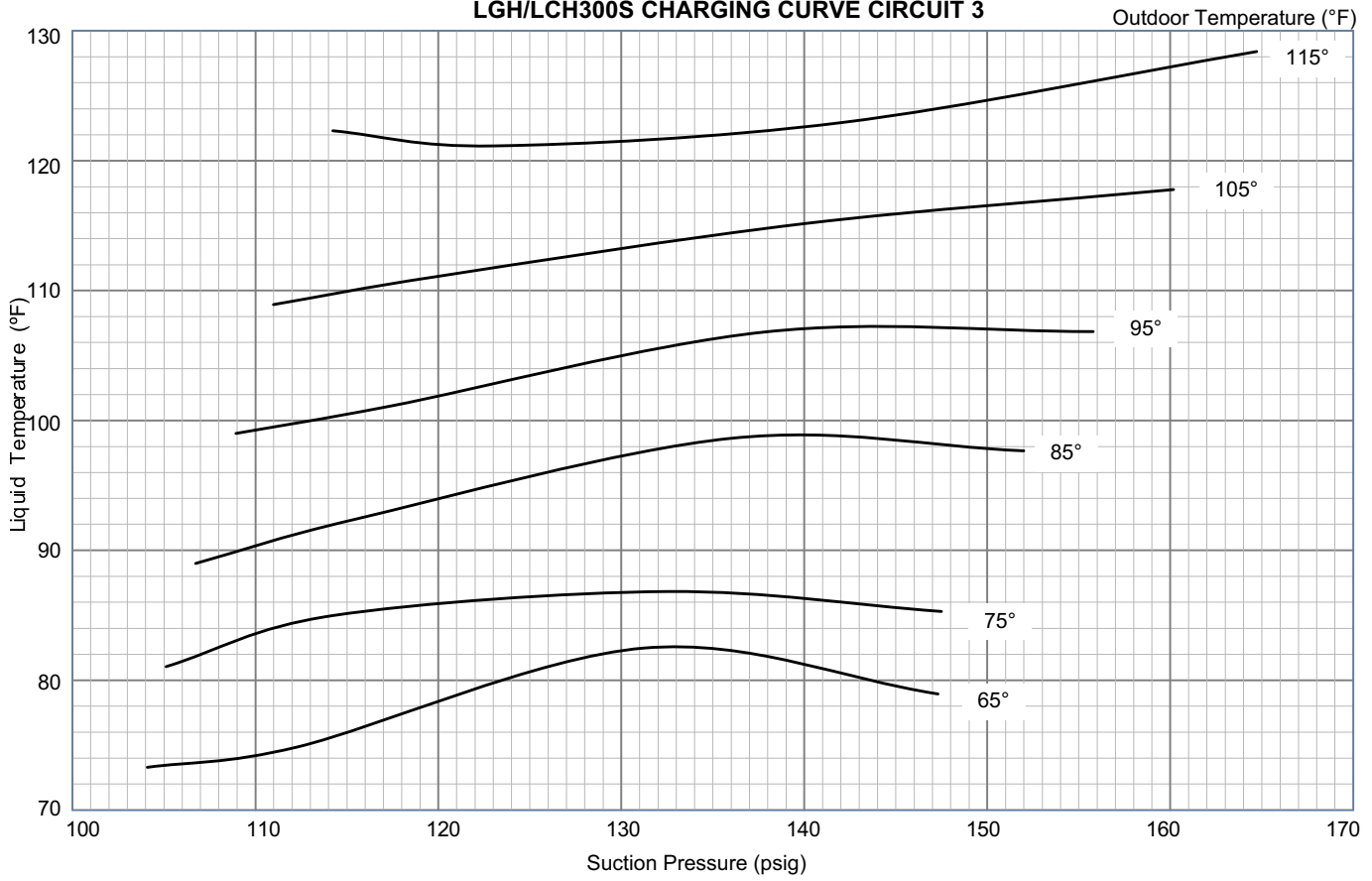

LGH/LCH300S CHARGING CURVE CIRCUIT 4

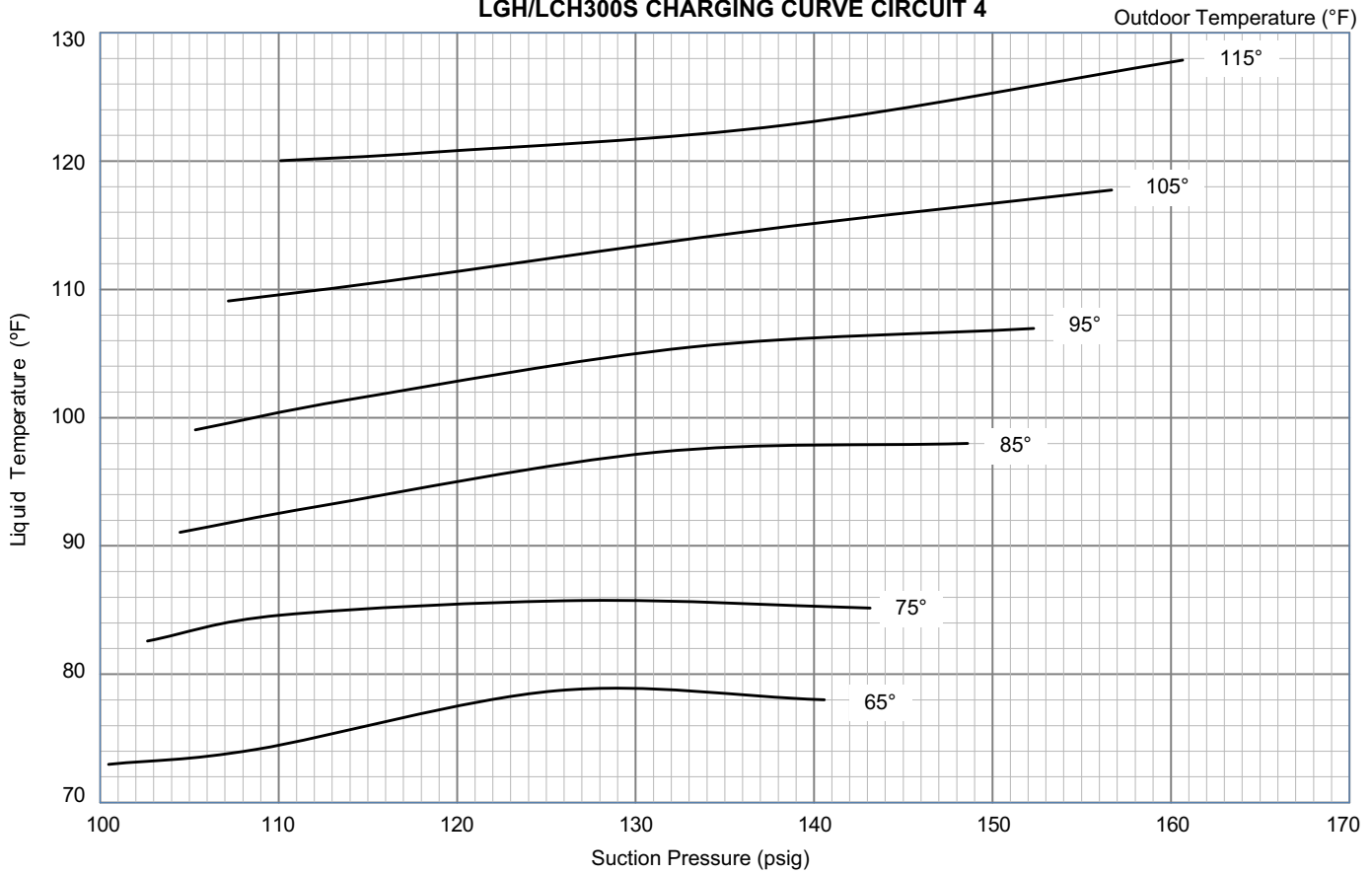

LGH/LCH300S REHEAT CHARGING CURVE CIRCUIT 1 Outdoor Temperature (°F)

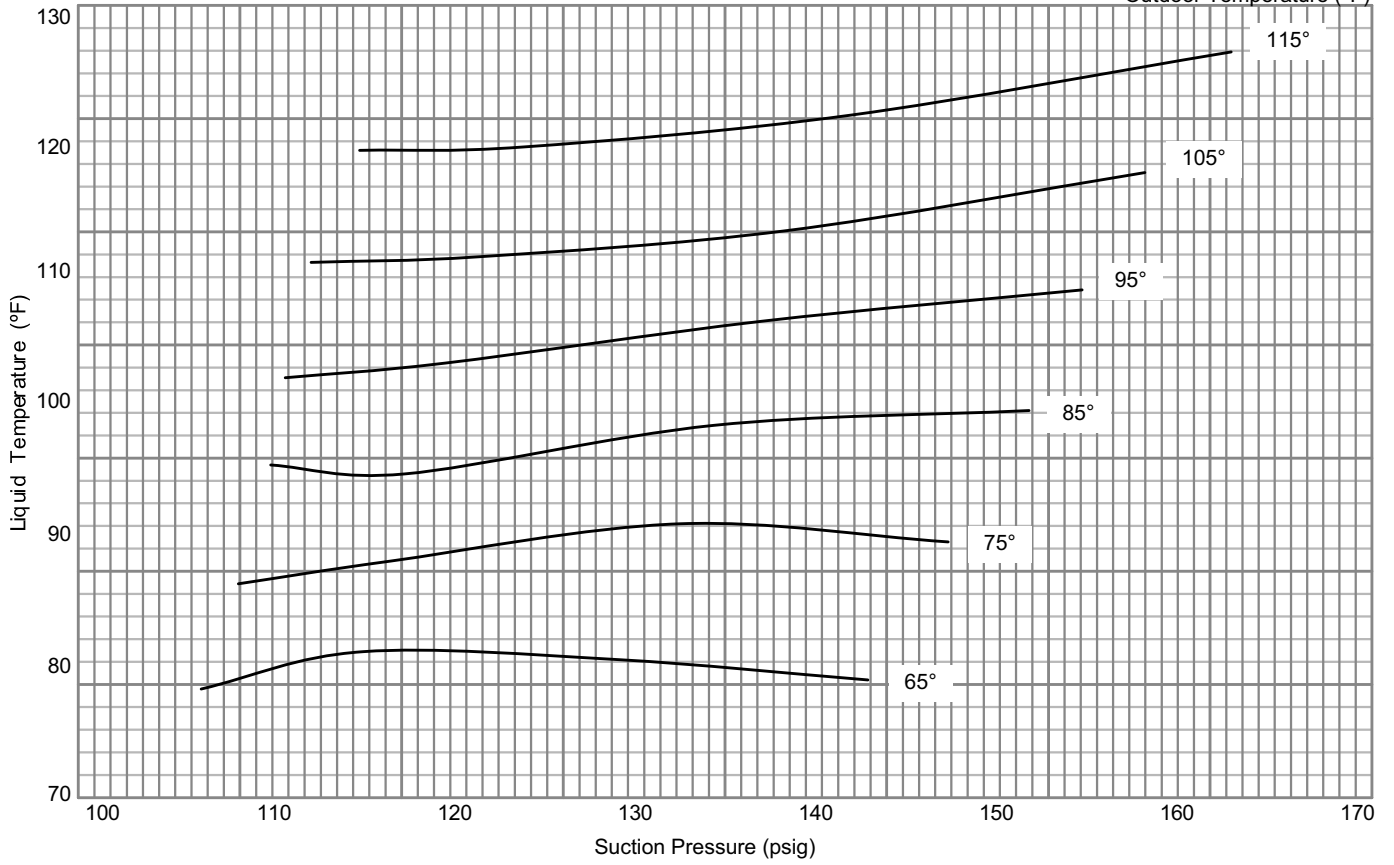

LGH/LCH300S REHEAT CHARGING CURVE CIRCUIT 2 Outdoor Temperature (°F)

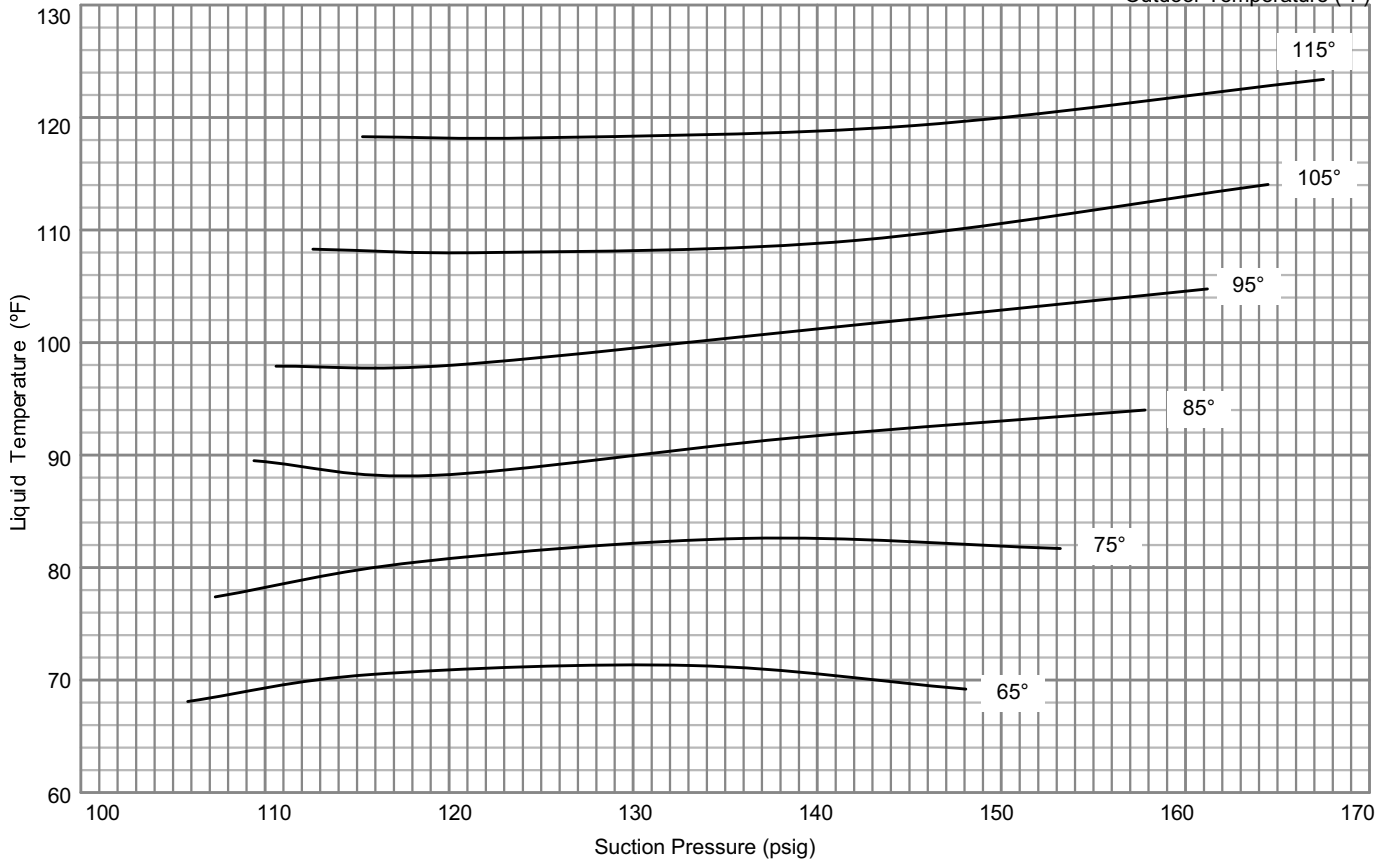

LGH/LCH300S REHEAT CHARGING CURVE CIRCUIT 3

Outdoor Temperature (°F)

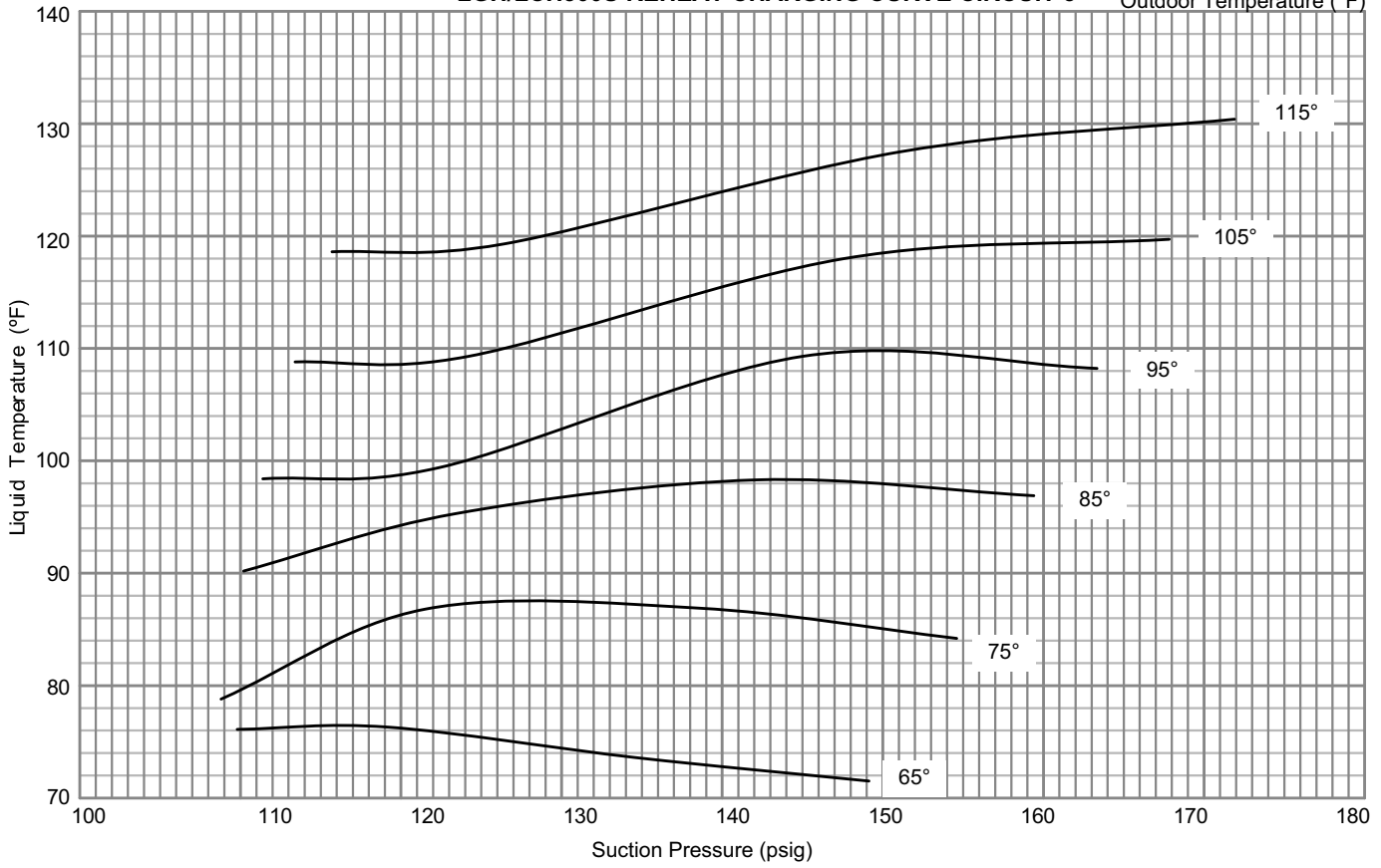

LGH/LCH300S REHEAT CHARGING CURVE CIRCUIT 4

Outdoor Temperature (°F)

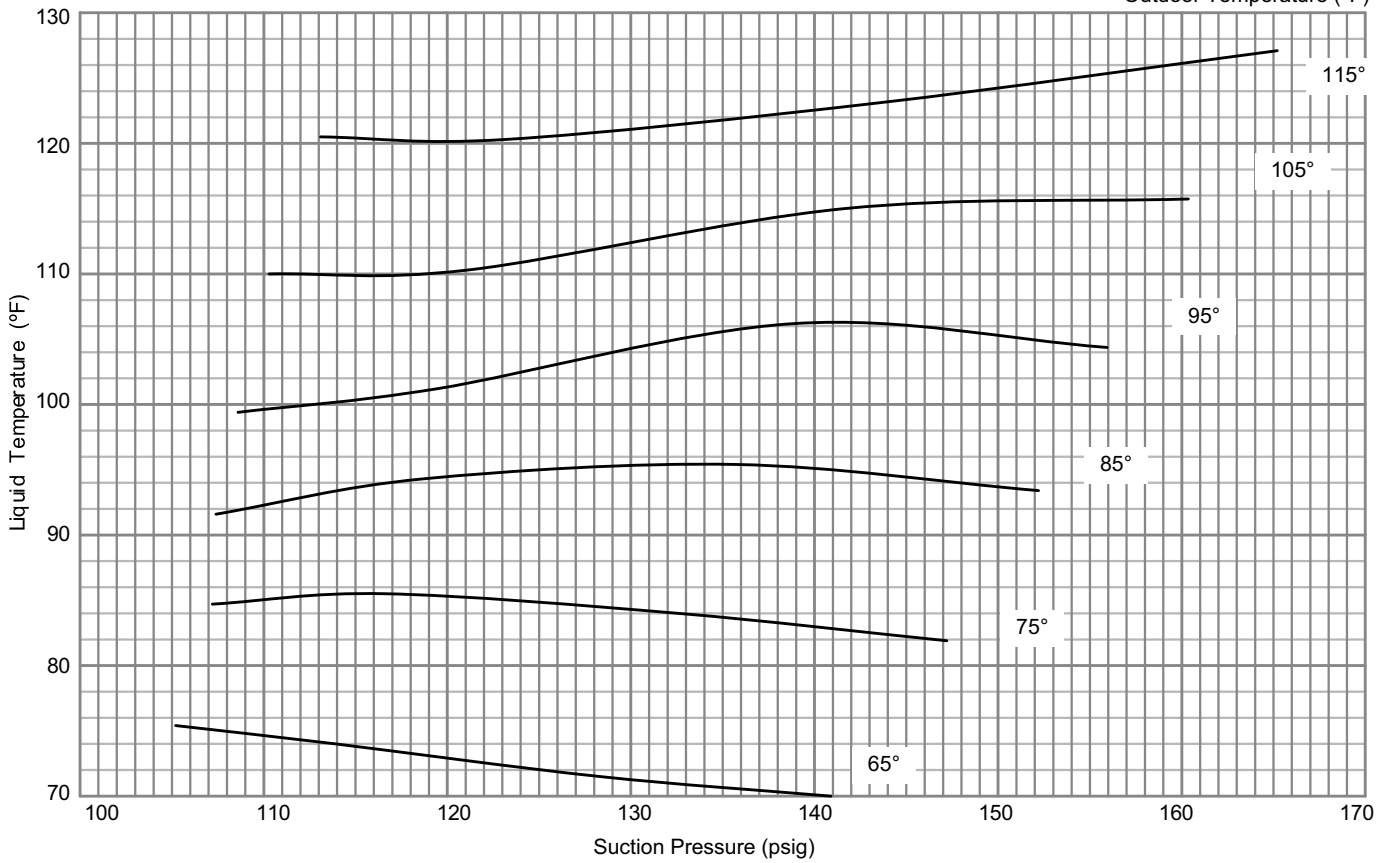

B-Fin/Tube Coil

WARNING-Do not exceed nameplate charge under any condition. This unit is factory charged and should require no further adjustment. If the system requires additional refrigerant, *reclaim the charge, evacuate the system and add required nameplate charge.*

NOTE - System charging is not recommended below 60°F (15°C). In temperatures below 60°F (15°C), the charge *must* be weighed into the system.

If weighing facilities are not available, or to check the charge, use the following procedure:

IMPORTANT - Charge unit in normal cooling mode.

1. Attach gauge manifolds and operate unit in cooling mode with economizer disabled until system stabilizes (approximately five minutes). Make sure all outdoor air dampers are closed.
2. Check each system separately with all stages operating.
3. Use a thermometer to accurately measure the outdoor ambient temperature.
4. Apply the outdoor temperature to tables 24 through 35 to determine normal operating pressures. Pressures are listed for sea level applications at 80°F dry bulb and 67°F wet bulb return air.
5. Compare the normal operating pressures to the pressures obtained from the gauges. Minor variations in these pressures may be expected due to differences in installations. Significant differences could mean that the system is not properly charged or that a problem exists with some component in the system. **Correct any system problems before proceeding.**
6. If discharge pressure is high, remove refrigerant from the system. If discharge pressure is low, add refrigerant to the system.
 - Add or remove charge in increments.
 - Allow the system to stabilize each time refrigerant is added or removed.
7. Use the following approach method along with the normal operating pressures to confirm readings.

TABLE 24
LG/LC Series 156H Std.

Outdoor Coil Entering Air Temp	Circuit 1		Circuit 2		Circuit 3	
	Dis. ±10 psig	Suc. ±5 psig	Dis. ±10 psig	Suc. ±5 psig	Dis. ±10 psig	Suc. ±5 psig
65°F	255	136	263	136	273	140
75°F	292	139	301	139	311	144
85°F	333	141	342	141	353	146
95°F	378	144	387	143	398	148
105°F	431	148	438	145	449	150
115°F	484	150	490	146	502	152

TABLE 25
LG/LC Series 156H Reheat

Outdoor Coil Entering Air Temp	Circuit 1		Circuit 2		Circuit 3	
	Dis. ±10 psig	Suc. ±5 psig	Dis. ±10 psig	Suc. ±5 psig	Dis. ±10 psig	Suc. ±5 psig
65°F	265	134	273	135	273	140
75°F	302	138	311	138	311	144
85°F	343	140	352	140	353	146
95°F	388	143	397	142	398	148
105°F	441	147	448	144	449	150
115°F	494	149	500	145	502	152

TABLE 26
LG/LC Series 180H Std.

Outdoor Coil Entering Air Temp	Circuit 1		Circuit 2		Circuit 3	
	Dis. ±10 psig	Suc. ±5 psig	Dis. ±10 psig	Suc. ±5 psig	Dis. ±10 psig	Suc. ±5 psig
65°F*	248	137	257	135	259	137
75°F	285	139	294	137	296	137
85°F	328	143	336	139	338	140
95°F	374	146	383	141	385	144
105°F	425	148	433	144	435	147
115°F	479	151	488	147	488	151

TABLE 27
LG/LC Series 180H Reheat

Outdoor Coil Entering Air Temp	Circuit 1		Circuit 2		Circuit 3	
	Dis. ±10 psig	Suc. ±5 psig	Dis. ±10 psig	Suc. ±5 psig	Dis. ±10 psig	Suc. ±5 psig
65°F*	258	136	267	133	259	137
75°F	295	138	304	135	296	137
85°F	338	142	346	137	338	140
95°F	384	145	393	139	385	144
105°F	435	147	443	142	435	147
115°F	488	150	498	145	488	151

TABLE 28
LG/LC Series 180U

Outdoor Coil Entering Air Temp	Circuit 1		Circuit 2	
	Dis. ±10 psig	Suc. ±5 psig	Dis. ±10 psig	Suc. ±5 psig
65°F	246	135	256	136
75°F	282	138	293	139
85°F	324	140	336	142
95°F	368	142	387	145
105°F	407	145	421	147
115°F	461	148	475	151

TABLE 29
LG/LC Series 210H Std.

Outdoor Coil En- tering Air Temp	Circuit 1		Circuit 2		Circuit 3	
	Dis. ±10 psig	Suc. ±5 psig	Dis. ±10 psig	Suc. ±5 psig	Dis. ±10 psig	Suc. ±5 psig
65°F*	246	138	252	142	264	138
75°F	284	142	294	145	306	140
85°F	326	145	335	147	348	142
95°F	373	148	380	149	393	144
105°F	422	150	430	151	441	145
115°F	472	153	482	154	492	148

TABLE 30
LG/LC Series 210H Reheat

Outdoor Coil En- tering Air Temp	Circuit 1		Circuit 2		Circuit 3	
	Dis. ±10 psig	Suc. ±5 psig	Dis. ±10 psig	Suc. ±5 psig	Dis. ±10 psig	Suc. ±5 psig
65°F*	258	136	264	141	264	138
75°F	296	140	306	144	306	140
85°F	338	143	347	146	348	142
95°F	385	146	392	148	393	144
105°F	434	148	442	150	441	145
115°F	484	151	494	153	492	148

TABLE 31
LG/LC Series 240H Std.

Outdoor Coil En- tering Air Temp	Circuit 1		Circuit 2		Circuit 3		Circuit 4	
	Dis. ±10 psig	Suc. ±5 psig	Dis. ±10 psig	Suc. ±5 psig	Dis. ±10 psig	Suc. ±5 psig	Dis. ±10 psig	Suc. ±5 psig
65°F*	255	137	246	132	260	141	252	135
75°F	291	140	284	137	298	144	290	137
85°F	332	142	325	140	340	146	331	139
95°F	378	145	371	142	385	148	377	141
105°F	428	148	421	145	436	150	428	143
115°F	481	151	473	148	488	153	479	145

TABLE 32
LG/LC Series 240H Reheat

Outdoor Coil En- tering Air Temp	Circuit 1		Circuit 2		Circuit 3		Circuit 4	
	Dis. ±10 psig	Suc. ±5 psig	Dis. ±10 psig	Suc. ±5 psig	Dis. ±10 psig	Suc. ±5 psig	Dis. ±10 psig	Suc. ±5 psig
65°F*	270	13	261	130	260	141	252	135
75°F	306	137	299	135	298	144	290	137
85°F	347	140	340	137	340	146	331	139
95°F	393	143	386	140	385	148	377	141
105°F	443	145	436	143	436	150	428	143
115°F	496	148	488	145	488	153	479	145

TABLE 33
LG/LC Series 240U

Outdoor Coil En- tering Air Temp	Circuit 1		Circuit 2	
	Dis. ±10 psig	Suc. ±5 psig	Dis. ±10 psig	Suc. ±5 psig
65°F	251	127	262	128
75°F	290	132	303	133
85°F	331	135	347	136
95°F	376	137	394	139
105°F	426	141	443	142
115°F	479	144	495	145

TABLE 34
LG/LC Series 300S Std.

Outdoor Coil En- tering Air Temp	Circuit 1		Circuit 2		Circuit 3		Circuit 4	
	Dis. ±10 psig	Suc. ±5 psig	Dis. ±10 psig	Suc. ±5 psig	Dis. ±10 psig	Suc. ±5 psig	Dis. ±10 psig	Suc. ±5 psig
65°F	272	129	273	128	280	129	277	127
75°F	311	132	303	131	321	131	317	129
85°F	357	134	349	133	367	133	363	130
95°F	403	137	397	137	418	135	406	134
105°F	451	139	453	140	475	138	471	136
115°F	502	142	506	142	532	144	529	140

TABLE 35
LG/LC Series 300S Reheat

Outdoor Coil En- tering Air Temp	Circuit 1		Circuit 2		Circuit 3		Circuit 4	
	Dis. ±10 psig	Suc. ±5 psig	Dis. ±10 psig	Suc. ±5 psig	Dis. ±10 psig	Suc. ±5 psig	Dis. ±10 psig	Suc. ±5 psig
65°F	285	128	284	128	280	129	277	127
75°F	324	132	315	130	321	131	317	129
85°F	368	134	358	132	367	133	363	130
95°F	418	136	406	136	418	136	406	135
105°F	466	138	462	138	475	138	471	136
115°F	517	141	515	141	532	144	529	140

TABLE 36
LG/LC Series 300U Std. - 580965-01

Outdoor Coil En- tering Air Temp	Circuit 1		Circuit 2	
	Dis. ±10 psig	Suc. ±5 psig	Dis. ±10 psig	Suc. ±5 psig
65°F	268	119	265	113
75°F	313	128	309	120
85°F	358	135	351	126
95°F	409	140	405	131
105°F	470	143	463	136
115°F	532	151	505	127

C-Charge Verification - Approach Method - AHRI Testing (Fin/Tube Coil)

- Using the same thermometer, compare liquid temperature to outdoor ambient temperature.

Approach Temperature = Liquid temperature (at condenser outlet) minus ambient temperature.

- Approach temperature should match values in table 37. An approach temperature greater than value shown indicates an undercharge. An approach temperature less than value shown indicates an overcharge.
- The approach method is not valid for grossly over or undercharged systems. Use tables 24 through 35 as a guide for typical operating pressures.

**TABLE 37
APPROACH TEMPERATURES - FIN/TUBE COIL**

L Series Unit	Liquid Temp. Minus Ambient Temp.			
	1st Stage	2nd Stage	3rd Stage	4th Stage
156H Std.	9°F ± 1 (5.0°C ±0.5)	9°F ± 1 (5.0°C ±0.5)	11°F ± 1 (6.1°C ±0.5)	NA
156H Reheat	6°F ± 1 (3.3°C ±0.5)	6°F ± 1 (3.3°C ±0.5)	11°F ± 1 (6.1°C ±0.5)	NA
180H Std.	6°F ± 1 (3.3°C ±0.5)	6°F ± 1 (3.3°C ±0.5)	6°F ± 1 (3.3°C ±0.5)	NA
180H Reheat	4°F ± 1 (2.2°C ±0.5)	4°F ± 1 (2.2°C ±0.5)	6°F ± 1 (3.3°C ±0.5)	NA
180U	5°F ± 1 (2.8°C ±0.5)	6.5°F ± 1 (3.6°C ±0.5)	NA	NA
210H Std.	6°F ± 1 (3.3°C ±0.5)	6°F ± 1 (3.3°C ±0.5)	7°F ± 1 (3.9°C ±0.5)	NA
210H Reheat	4°F ± 1 (2.2°C ±0.5)	4°F ± 1 (2.2°C ±0.5)	7°F ± 1 (3.9°C ±0.5)	NA
240H Std.	6°F ± 1 (3.3°C ±0.5)	6°F ± 1 (3.3°C ±0.5)	7°F ± 1 (3.9°C ±0.5)	7°F ± 1 (3.9°C ±0.5)
240H Reheat	4°F ± 1 (2.2°C ±0.5)	4°F ± 1 (2.2°C ±0.5)	8°F ± 1 (4.4°C ±0.5)	8°F ± 1 (4.4°C ±0.5)
240U	4°F ± 1 (2.2°C ±0.5)	6.5°F ± 1 (3.6°C ±0.5)	NA	NA
300S Std.	5°F ± 1 (2.8°C ±0.5)	5°F ± 1 (2.8°C ±0.5)	8°F ± 1 (4.4°C ±0.5)	8°F ± 1 (4.4°C ±0.5)
300S Reheat	3°F ± 1 (1.7°C ±0.5)	3°F ± 1 (1.7°C ±0.5)	8°F ± 1 (4.4°C ±0.5)	8°F ± 1 (4.4°C ±0.5)
300U	4°F ± 1 (2.2°C ±0.5)	10°F ± 1 (5.5°C ±0.5)	NA	NA

IV-STARTUP - OPERATION

Refer to startup directions and to the unit wiring diagram when servicing. See unit nameplate for minimum circuit ampacity and maximum fuse size.

A-Preliminary and Seasonal Checks

- Make sure the unit is installed in accordance with the installation instructions and applicable codes.
- Inspect all electrical wiring, both field and factory installed for loose connections. Tighten as required. Refer to unit diagram located on inside of unit control box cover.
- Check to ensure that refrigerant lines are in good condition and do not rub against the cabinet or other refrigerant lines.
- Check voltage. Voltage must be within the range listed on the nameplate. If not, consult power company and have the voltage corrected before starting the unit.
- Recheck voltage and amp draw with unit running. If voltage is not within range listed on unit nameplate, stop unit and consult power company. Refer to unit nameplate for maximum rated load amps.
- Inspect and adjust blower belt (see section on Blower Compartment - Blower Belt Adjustment).

B-Cooling Startup See figure 26 and 27

NOTE-Crankcase heaters must be energized 24 hours before attempting to start compressor. Set thermostat so that there is no demand to prevent compressor from cycling. Apply power to unit.

- Initiate first and second stage cooling demands according to instructions provided with thermostat.
- First-stage thermostat demand will energize compressors 1 and 2 on all standard and high efficient units. Second-stage thermostat demand will energize compressor 3 on all standard and high efficiency units and compressor 4 on LGH240H/300. First-stage thermostat demand will energize one compressor from each circuit on ultra high efficiency units. Second-stage thermostat demand will energize the remaining two compressors, one in each circuit, on ultra high efficiency units.
- Units contain three or four refrigerant circuits or stages.
- Each refrigerant circuit is separately charged with refrigerant. See unit rating plate for correct amount of charge.

NOTE - Refer to III-CHARGING for proper method to check refrigerant charge.

156, 180H, & 210 REFRIGERANT CIRCUITS

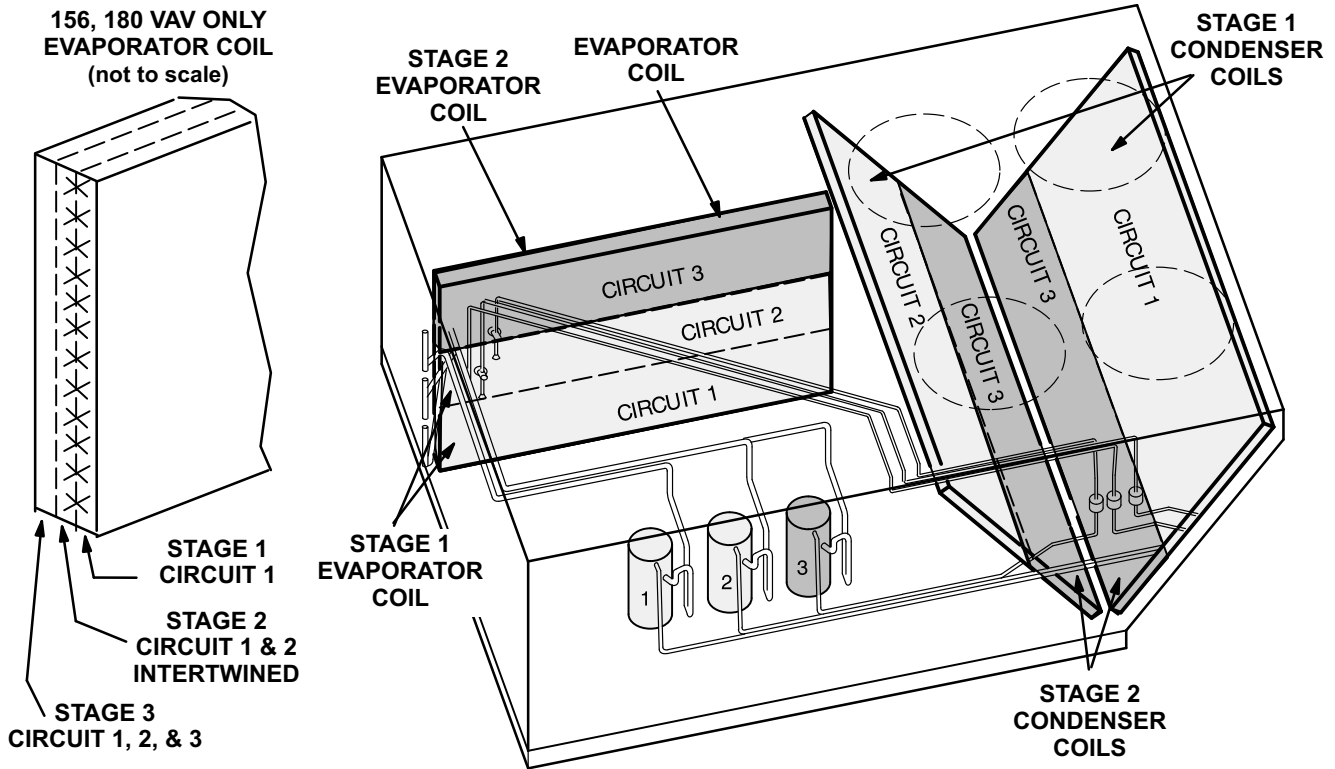

240H & 300S REFRIGERANT CIRCUITS

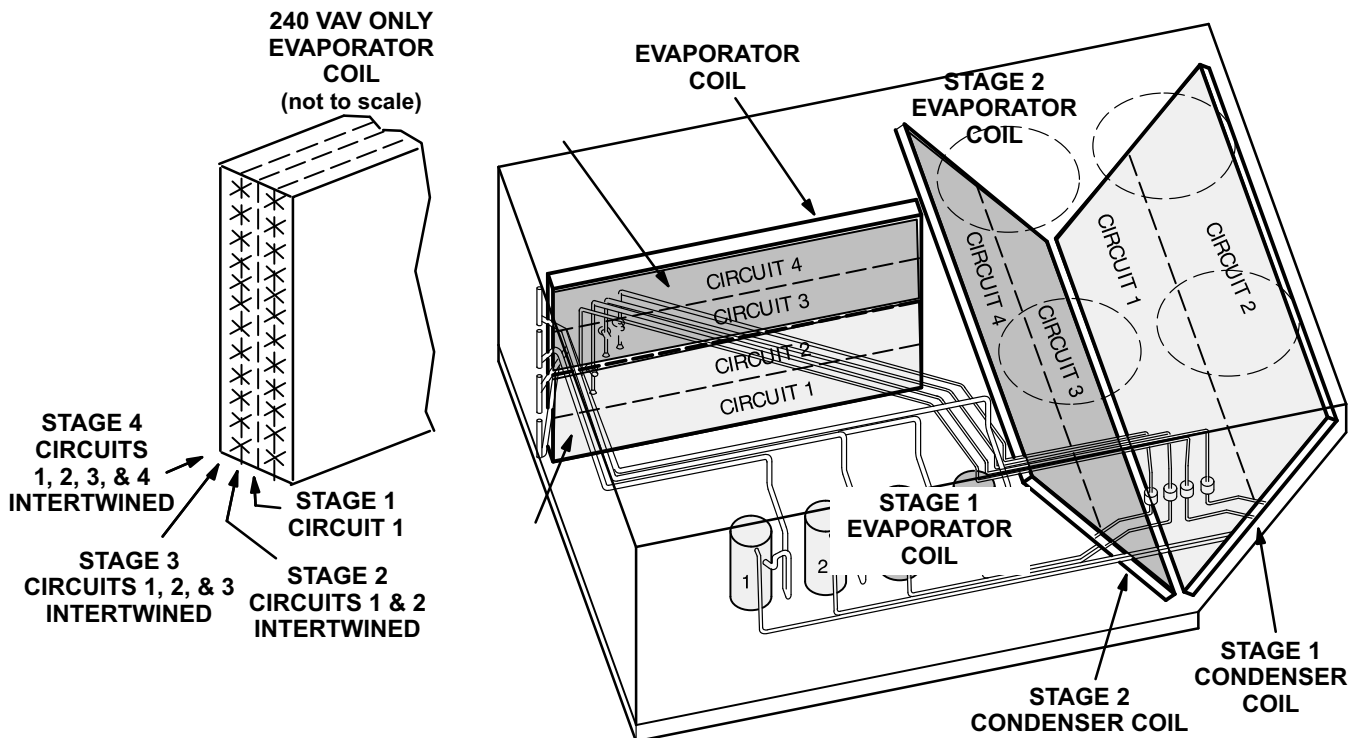
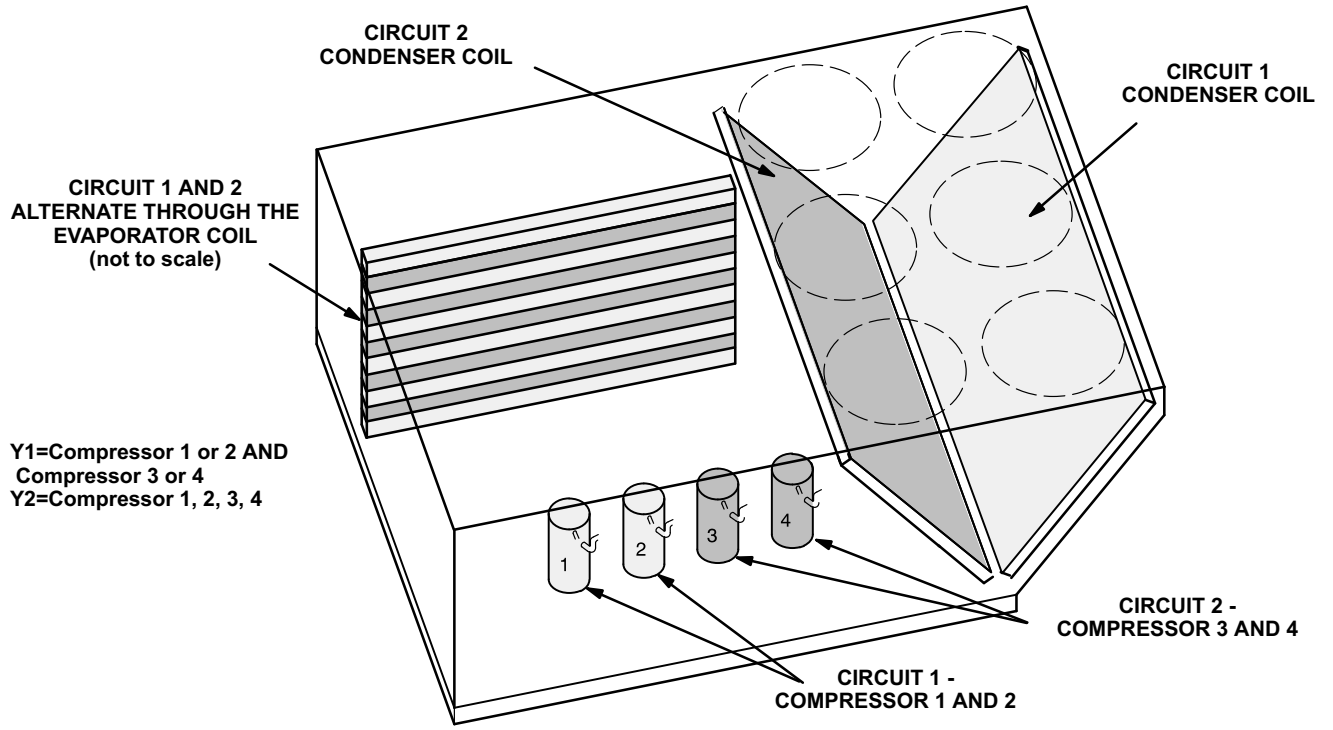

FIGURE 26

REFRIGERANT CIRCUITS - 180U, 240U, 300U



180U & 240U COMPRESSOR DETAIL

FIGURE 27

C-Heating Startup

FOR YOUR SAFETY READ BEFORE LIGHTING

! WARNING	
	Danger of explosion. Can cause injury or product or property damage. If overheating occurs or if gas supply fails to shut off, shut off the manual gas valve to the appliance before shutting off electrical supply.

! WARNING	
	Electric shock hazard. Can cause injury or death. Before attempting to perform any service or maintenance, turn the electrical power to unit OFF at disconnect switch(es). Unit may have multiple power supplies.

BEFORE LIGHTING smell all around the appliance area for gas. Be sure to smell next to the floor because some gas is heavier than air and will settle on the floor.

Use only your hand to push in or turn the gas control knob. Never use tools. If the knob will not push in or turn by hand, do not try to repair it, call a qualified service technician. Force or attempted repair may result in a fire or explosion.

! IMPORTANT	
This unit is equipped with an automatic spark ignition system. Do not attempt to light manually.	

In case of a safety shutdown, move thermostat switch to **OFF** and return the thermostat switch to **HEAT** to reset ignition control.

Placing Furnace In Operation

Gas Valve Operation for Honeywell VR8205Q/VR8305Q (figure 28)

- 1- Set thermostat to lowest setting.
- 2- Turn off all electrical power to appliance.
- 3- This appliance is equipped with an ignition device which automatically lights the burner. Do **not** try to light the burner by hand.
- 4- Open or remove the heat section access panel.
- 5- Turn the knob on the gas valve clockwise  to "**OFF**". Do not force.

- 6- Wait five (5) minutes to clear out any gas. If you then smell gas, **STOP!** Immediately call your gas supplier from a neighbor's phone. Follow the gas supplier's instructions. If you do not smell gas, go to the next step.

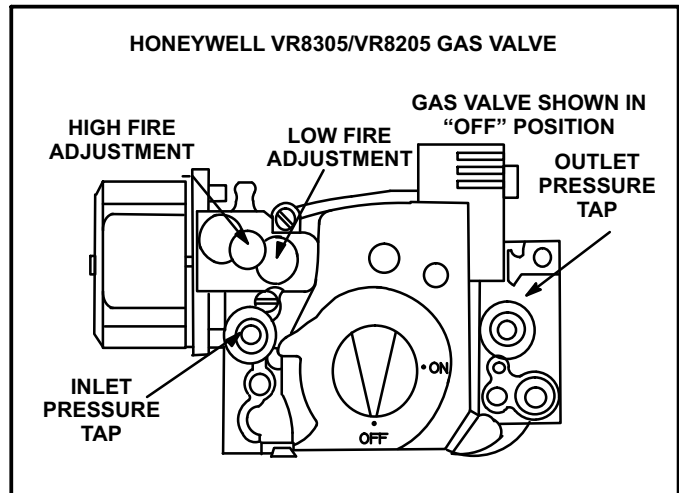



FIGURE 28

- 7- Turn the knob on the gas valve counterclockwise  to "**ON**". Do not force.
- 8- Close or replace the heat section access panel.
- 9- Turn on all electrical power to appliance.
- 10- Set thermostat to desired setting.
- 11- The combustion air inducer will start. The burners will light within 40 seconds.
- 12- If the appliance does not light the first time (gas line not fully purged), it will attempt up to two more ignitions before locking out.
- 13- If lockout occurs, repeat steps 1 through 10.
- 14- If the appliance will not operate, follow the instructions "Turning Off Gas to Appliance" and call your service technician or gas supplier.

Turning Off Gas to Appliance

- 1- If using an electromechanical thermostat, set to the lowest setting.
- 2- Before performing any service, turn off all electrical power to the appliance.
- 3- Open or remove the heat section access panel.
- 4- Turn the knob on the gas valve clockwise  to "**OFF**". Do not force.

D-Safety or Emergency Shutdown

Turn off power to the unit. Close manual and main gas valves.

V- SYSTEMS SERVICE CHECKS

A-Heating System Service Checks

All LGH units are ETL/CSA design certified without modification.

Before checking piping, check with gas company or authorities having jurisdiction for local code requirements. Refer to the LGH Installation, Operation and Maintenance instruction for more information.

1-Gas Piping

Gas supply piping must not allow more than 0.5"W.C. (124.3 Pa) drop in pressure between the gas meter and the unit. Supply gas pipe must not be smaller than the unit gas connection. Refer to installation instructions for details.

2-Testing Gas Piping

NOTE-In case emergency shutdown is required, turn off the main manual shut-off valve and disconnect the main power to the unit. These controls should be properly labeled by the installer.

When pressure testing gas lines, the gas valve must be disconnected and isolated. **Gas valves can be damaged if subjected to more than 0.5 psig [14"W.C. (3481 Pa)].** See figure 29.

When checking piping connection for gas leaks, use the preferred means. Common kitchen detergents can cause harmful corrosion on various metals used in gas piping. The use of specialty Gas Leak Detector is strongly recommended. It is available through Lennox under part number 31B2001. See CORP 8411-L10, for further details.

Do not use matches, candles, flame or any other source of ignition to check for gas leaks.

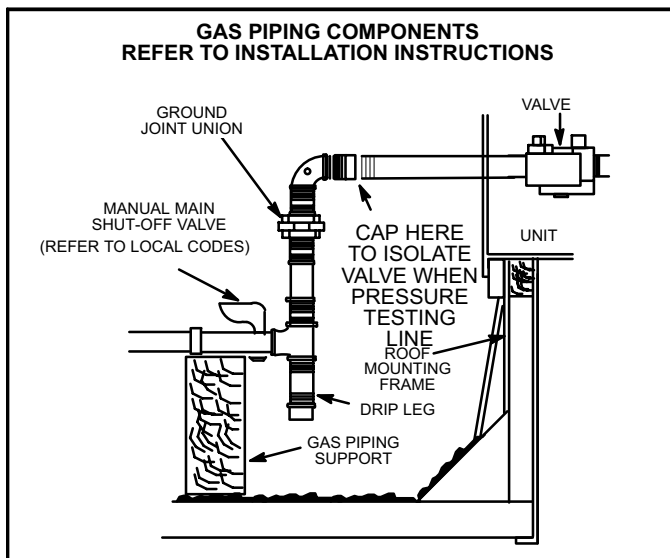

FIGURE 29

3-Testing Gas Supply Pressure

When testing gas supply pressure, connect test gauge to the inlet pressure tap located on unit gas valve GV1 and or GV3. Test supply gas pressure with unit firing at maximum rate (both stages energized). Make sure the reading falls within the range of the following values. Low pressure may result in erratic operation or "underfire." High pressure can result in permanent damage to the gas valve or "overfire." For natural gas units, operating pressure at the unit gas connection must be between 4.7"W.C. and 10.5"W.C. (1168 Pa and 2610 Pa). For L.P. gas units, operating pressure at the unit gas connection must be between 10.8"W.C. and 13.5"W.C. (2685.3 Pa and 3356.7 Pa).

On multiple unit installations, each unit should be checked separately while operating at maximum rate, beginning with the one closest to the supply gas main and progressing to the one furthest from the main. Multiple units should also be tested with and without the other units operating. Supply pressure must fall within the range listed in the previous paragraph.

4-Check and Adjust Manifold Pressure

After line pressure has been checked and adjusted, check manifold pressure. Move test gauge to the outlet pressure tap located on unit gas valve GV1 and or GV3. See figure 28 for location of pressure tap on the gas valve.

The manifold pressure is factory set and should not require adjustment. If manifold pressure is incorrect and no other source of improper manifold pressure can be found, the valve must be replaced. See figure 28 for location of gas valve (manifold pressure) adjustment screw.

All gas valves are factory regulated. The gas valve should completely and immediately cycle off in the event of gas or power failure. The manual shut-off knob can be used to immediately shut off gas supply.

CAUTION

For safety, connect a shut-off valve between the manometer and the gas tap to permit shut off of gas pressure to the manometer.

Manifold Adjustment Procedure

- 1- Connect test gauge to the outlet pressure tap on the gas valve. Start the unit (call for second stage heat) and allow five minutes for the unit to reach steady state.
- 2- While waiting for the unit to stabilize, notice the flame. The flame should be stable without flashback and should not lift from the burner heads. Natural gas should burn basically blue with some clear streaks. L.P. gas should burn mostly blue with some clear yellow streaks.
- 3- After allowing the unit to stabilize for five minutes, record the manifold pressure and compare to the values given in table 10.

CAUTION

Disconnect heating demand as soon as an accurate reading has been obtained.

Combustion gases

Flue products must be analyzed and compared to the unit specifications. Problems detected during the inspection may make it necessary to temporarily shut down the furnace until the items can be repaired or replaced.

5-Proper Gas Flow

To check for proper gas flow to burners, determine Btuh input from unit rating plate or the gas heating capacity in the SPECIFICATIONS tables. Divide this input rating by the Btuh per cubic foot of available gas. Result is the number of cubic feet per hour required. Determine the flow of gas through gas meter for two minutes and multiply by 30 to get hourly flow of gas to the burners.

NOTE - To obtain accurate reading, shut off all other gas appliances connected to meter.

6-Inshot Burner

Burners are factory set for maximum air and cannot be adjusted. Always operate unit with access panel in place. A peep hole is furnished in the heating access panel for flame viewing. Natural gas should burn basically blue with some clear streaks. L.P. gas should burn mostly blue with some clear yellow streaks.

Figure 30 shows how to remove burner assembly.

- 1- Turn off power to unit and shut off gas supply.
- 2- Remove screws holding the burner support cap.
- 3- Slide each burner off its orifice.
- 4- Clean and reassemble (reverse steps 1-3).
- 5- Be sure to secure all wires and check plumbing.
- 6- Turn on power to unit. Follow lighting instructions attached to unit and operate unit in heating mode. Check burner flames. They should be blue with yellow streaks.

7-Spark Electrode Gap

The spark electrode assembly can be removed for inspection by removing two screws securing the electrode assembly and sliding it out of unit.

For proper unit operation, electrodes must be positioned and gapped correctly.

Spark gap may be checked with appropriately sized twist drills or feeler gauges. Disconnect power to the unit and remove electrode assembly. The gap should be between 0.125" ± 0.015" (3.2 mm ± .4 mm). See figure 24.

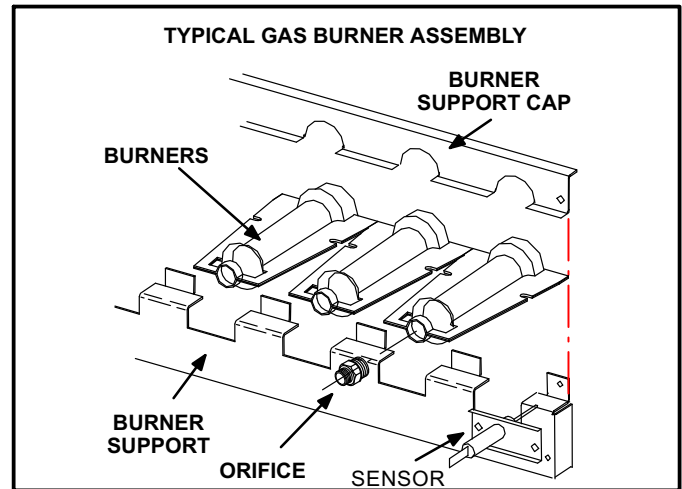

FIGURE 30

8-Heat Exchanger

To Access or Remove Heat Exchanger From Unit:

- 1- Turn off gas and electric power.
- 2- Remove access panel(s) and unit center mullion.
- 3- Remove gas valve, manifold assembly and burners.
- 4- Remove combustion air inducer and flue box. Pay careful attention to the order in which gaskets and orifice are removed.
- 5- Support heat exchanger (to prevent it from falling when final screws are removed.)
- 6- Remove screws supporting heat exchanger.
- 7- To install heat exchanger, reverse procedure. Be sure to secure all wires and check plumbing and burner plate for airtight seal. Screws must be torqued to 35 in.-lbs. to ensure proper operation.

9-Flame Sensing

Flame current is an electrical current which passes from the ignition control through the sensor electrode during unit operation. The current passes from the sensor through the flame to the ground electrode (located on the flame electrode) to complete a safety circuit. The electrodes should be located so the tips are at least 1/2" (12.7 mm) inside the flame envelope. Do not bend electrodes. To measure flame current, follow the procedure on the following page:

NOTE-Electrodes are not field adjustable. Any alterations to the electrode may create a hazardous condition that can cause property or personal injury.

- 1- Disconnect power to unit.
- 2- Remove lead from sensing electrode and install a 0-50DC microamp meter in series between the sensing electrode and the sensing lead.
- 3- Reconnect power and adjust thermostat for heating demand.
- 4- When flame is established, compare reading to table 38. Do not bend electrodes.
- 5- Disconnect power to unit before disconnecting meter. Make sure sensor wire is securely reconnected before reconnecting power to unit.

TABLE 38

Manufacturer	Nominal Signal Microamps	Drop Out
UTEC	0.5 - 1.0	.09

NOTE-If the meter scale reads 0, the leads are reversed. Disconnect power and reconnect leads for proper polarity.

10-Combustion Air Inducer

The combustion air inducer is factory set and is not field adjustable. However, operation should be monitored to ensure proper operation. The combustion air inducer is used to draw fresh air into the combustion chamber while simultaneously expelling exhaust gases. The inducer operates throughout the heating cycle.

On a heating demand, the ignition control is energized by the A55 Unit Controller. The ignition control then allows 30 to 40 seconds for the combustion air inducer to vent exhaust gases from the burners. When the combustion air inducer is purging the exhaust gases, the combustion air prove switch is closing proving that the combustion air inducer is operating before allowing the ignition control to energize. When the combustion air prove switch is closed and the delay is over, the ignition control activates the first stage operator of the gas valve (low fire), the spark and the flame sensing electrode. Sparking stops immediately after flame is sensed.

11-High Altitude

Units may be installed at altitudes up to 2000 feet (610 m) above sea level without any modification. At altitudes above 2000 feet (610 m), units must be derated to match gas manifold pressures shown in table below.

NOTE — This is the only permissible derate for these units.

Altitude - ft. (m)	Natural Gas		LPG/Propane	
	in. w.g.	kPa	in. w.g.	kPa
2001 - 3000 (610 - 915)	3.6	0.90	10.2	2.54
3001 - 4000 (915 - 1220)	3.5	0.87	9.9	2.46
4001 - 5000 (1220 - 1525)	3.4	0.85	9.6	2.39
5001 - 6000 (1525 - 1830)	3.3	0.82	9.4	2.34
6001 - 7000 (1830 - 2135)	3.2	0.80	9.1	2.26

B-Cooling System Service Checks

LGH units are factory charged and require no further adjustment; however, charge should be checked periodically using the approach method. The approach method compares actual liquid temperature with the outdoor ambient temperature. See section III- CHARGING.

NOTE-When unit is properly charged discharge line pressures should approximate those in tables NO TAG through NO TAG.

1-Oil Check Injection Procedure 180U, 240U, 300U

- 1- Run the unit in full load (both compressors running) for a minimum of thirty (30) minutes or until compressor sump superheat is above 20°F.
- 2- Check the oil level of the tandem compressor assembly using the sight glass installed in the oil equalization line near the base of the compressors. The oil level should be visible in the sight glass, preferably in the middle.
- 3- If the oil level is not visible in the sight glass continue on to steps 4-17 to add oil to the tandem compressor system(POE 32-3MAF oil recommended). The A/C Re-New Injector kit, part number 4057-99, Lennox catalogue number Y6630 is recommended for use when adding oil to a system.
- 4- With the unit running in full load, connect the high side manifold gauge hose to the open pressure tap fitting on the common discharge line (see Figure 31). Briefly crack the high side manifold gauge valve to purge the high side and middle manifold gauge hoses.
- 5- Connect the oil injector container to the middle manifold gauge hose. Remove the container from the lid (the end attached to the middle manifold gauge hose).
- 6- Attach a hose to the opposite end of the oil container which has a female, screw-on pressure tap fitting on one end and a shut-off valve on the other end (this hose is provided and is already attached to the oil container in the recommended injection kit listed above).
- 7- Clean the oil container of contaminants and debris. With the shut-off valve closed, add 4 fl. oz. of oil to the oil container (POE 32-3MAF oil recommended).
- 8- Re-install the lid, attached to the middle manifold gauge hose, onto the oil container.
- 9- With the shut-off valve closed, briefly crack the high side manifold gauge valve to pressurize the hoses and oil container.
- 10-Lightly thread the hose coming from the oil container onto the pressure tap fitting provided on the oil equalization line located near the base of the compressors (See Figure 31). Do not depress the Schrader Valve..
- 11-Briefly crack the shut-off valve to purge the hose going to the oil equalization line. While the shut-off valve is cracked, fully tighten the hose fitting onto the oil equalization line port.
- 12-Open the shut-off valve to allow the middle manifold gauge hose and the oil container to pressurize with suction pressure.
- 13-Open the high side manifold gauge valve for no more than 2 seconds to allow the contents of the oil container to flow into the oil equalization line.

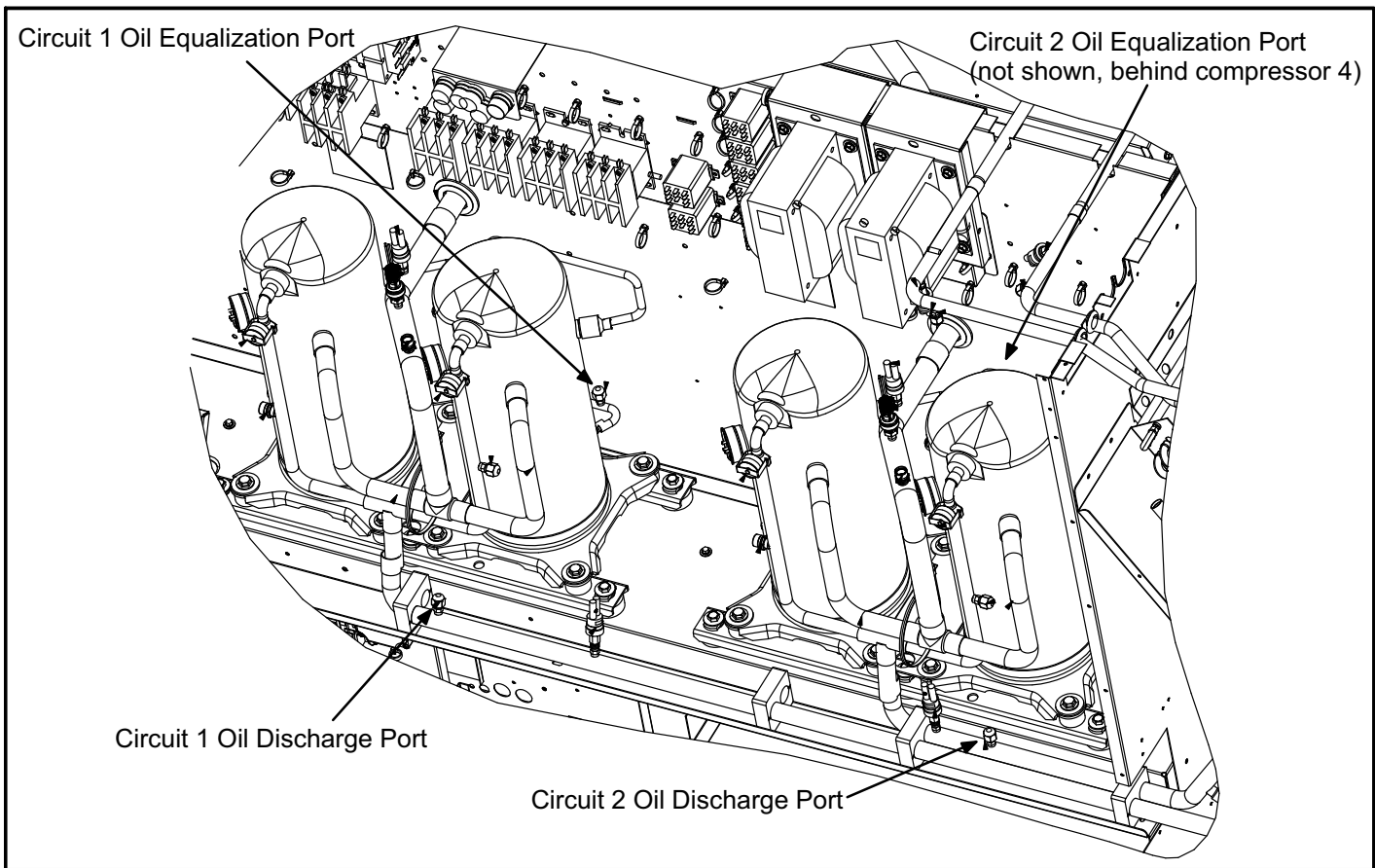

FIGURE 31

- 14- Allow the unit to continue to run in full load for a minimum of 5 minutes to allow the new oil level to stabilize. Re-check the oil level of the tandem compressor assembly.
- 15- If oil level is still not visible, close the shut-off valve on the hose attached to the oil equalization port and repeat steps 4 - 14 until oil level is in the middle of the sight glass.
- 16- Close the shut-off valve and disconnect hose from the oil equalization line..
- 17- Turn unit off and allow high side and low side pressures to equalize. Disconnect high side manifold gauge hose from the common discharge line.

B-Lubrication

All motors and blower wheels used in LGH units are lubricated; no further lubrication is required.

C-Supply Air Blower Wheel

Annually inspect supply air blower wheel for accumulated dirt or dust. Turn off power before attempting to remove access panel or to clean blower wheel.

D-Evaporator Coil

Inspect and clean coil at beginning of each season. Clean using mild detergent or commercial coil cleanser. Check condensate drain pan and line, if necessary. Flush coil and condensate drain with water taking care not to get insulation, filters and return air ducts wet. Check connecting lines and coil for evidence of oil and refrigerant leaks.

E-Condenser Coil

Clean condenser coil annually with detergent or commercial coil cleaner and inspect monthly during the cooling season. Check connecting lines and coil for evidence of oil and refrigerant leaks.

F-Electrical

- 1- Check all wiring for loose connections.
- 2- Check for correct voltage at unit (unit operating).
- 3- Check amp-draw on both condenser fan motor and blower motor.
 Fan Motor Rating Plate _____ Actual _____
 Indoor Blower Motor Rating Plate _____ Actual _____

VI-MAINTENANCE

! WARNING	
	<p>Electric shock hazard. Can cause injury or death. Before attempting to perform any service or maintenance, turn the electrical power to unit OFF at disconnect switch(es). Unit may have multiple power supplies.</p>

A-Filters

LGH units use six 24 X 24 X 2" fiberglass throw-away type filters. Filters may be accessed through the economizer / filter access door. Filters should be checked monthly (or more frequently in severe use) and cleaned or replaced regularly. Take note of the "AIR FLOW DIRECTION" marking on the filter frame when re-installing.

VII-ACCESSORIES

The accessories section describes the application of most of the optional accessories which can be factory or field installed to the LGH units.

A-Roof Curbs

When installing the LGH units on a combustible surface for downflow discharge applications, the Lennox hybrid C1CURB70C-1 8-in height, C1CURB71C-1 14-in height, C1CURB72C-01 18-in height and C1CURB73C-1 24-in roof mounting frame is used. The assembled hybrid mounting frame is shown in figure 32. Refer to the roof mounting frame installation instructions for details of proper assembly and mounting. The roof mounting frame MUST be squared to the roof and level before mounting. Plenum system MUST be installed before the unit is set on the mounting frame. Typical roof curbing and flashing is shown in figure 33. Refer to the roof mounting frame installation instructions for proper plenum construction and attachment.

For horizontal discharge applications, use the standard C1URB14C-1 26-in or C1CURB16C-1 37-in height roof mounting frame. This frame converts unit from down-flow to horizontal air flow. The 37 inch horizontal frame meets National Roofing Code requirements. The roof mounting frames are recommended in all other applications but not required. If the LGH units are not mounted on a flat (roof) surface, they MUST be supported under all edges and under the middle of the unit to prevent sagging. The units MUST be mounted level within 1/16" per linear foot or 5mm per meter in any direction.

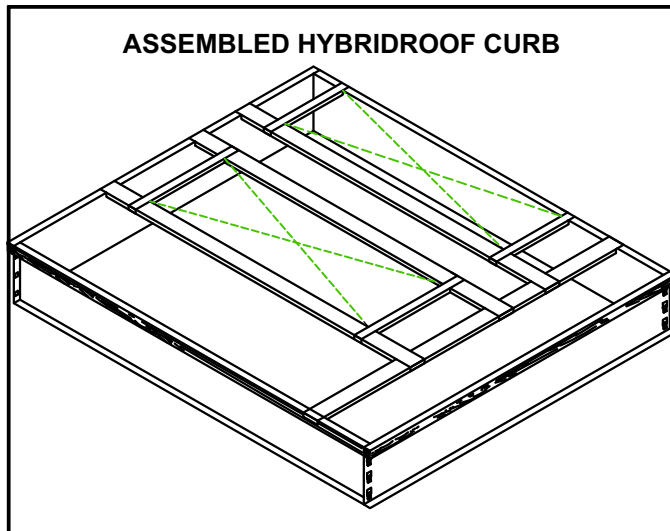

FIGURE 32

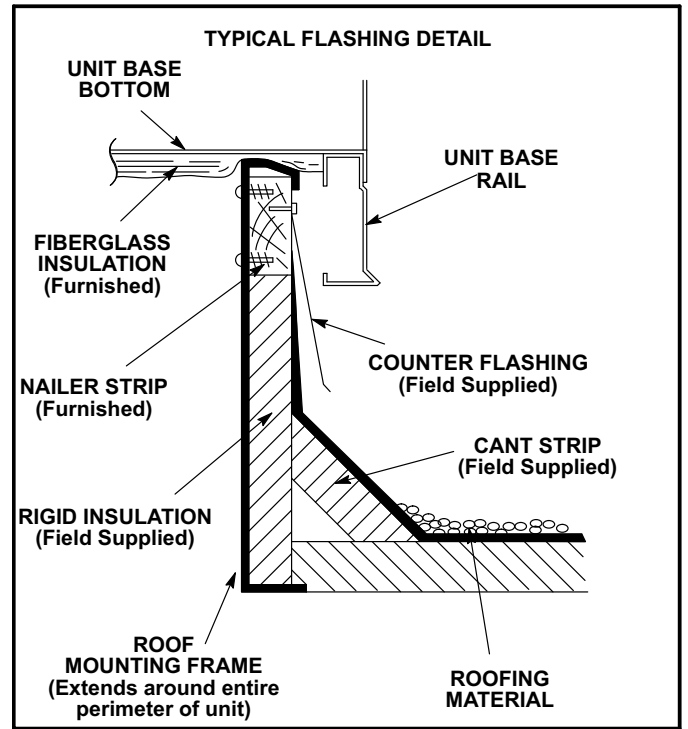

FIGURE 33

B-Transitions

Optional supply/return transitions C1DIFF33C-1 and C1DIFF34C-1 are available for use with LGH series units utilizing optional C1CURB roof curbs. Transition must be installed in the roof curb before mounting the unit to the frame. Refer to the manufacturer's instructions included with the transition for detailed installation procedures.

C-C1DAMP10 & E1DAMP20 Outdoor Air Dampers

C1DAMP10C and E1DAMP20C (figure 34) consist of a set of dampers which may be manually or motor operated to allow up to 25 percent outside air into the system at all times (see figure 34). Either air damper can be installed in LGH units. Washable filter supplied with the outdoor air dampers can be cleaned with water and a mild detergent. It should be sprayed with Filter Handicoater when dry prior to reinstallation. Filter Handicoater is R.P. Products coating no. 418 and is available as Lennox Part No. P-8-5069.

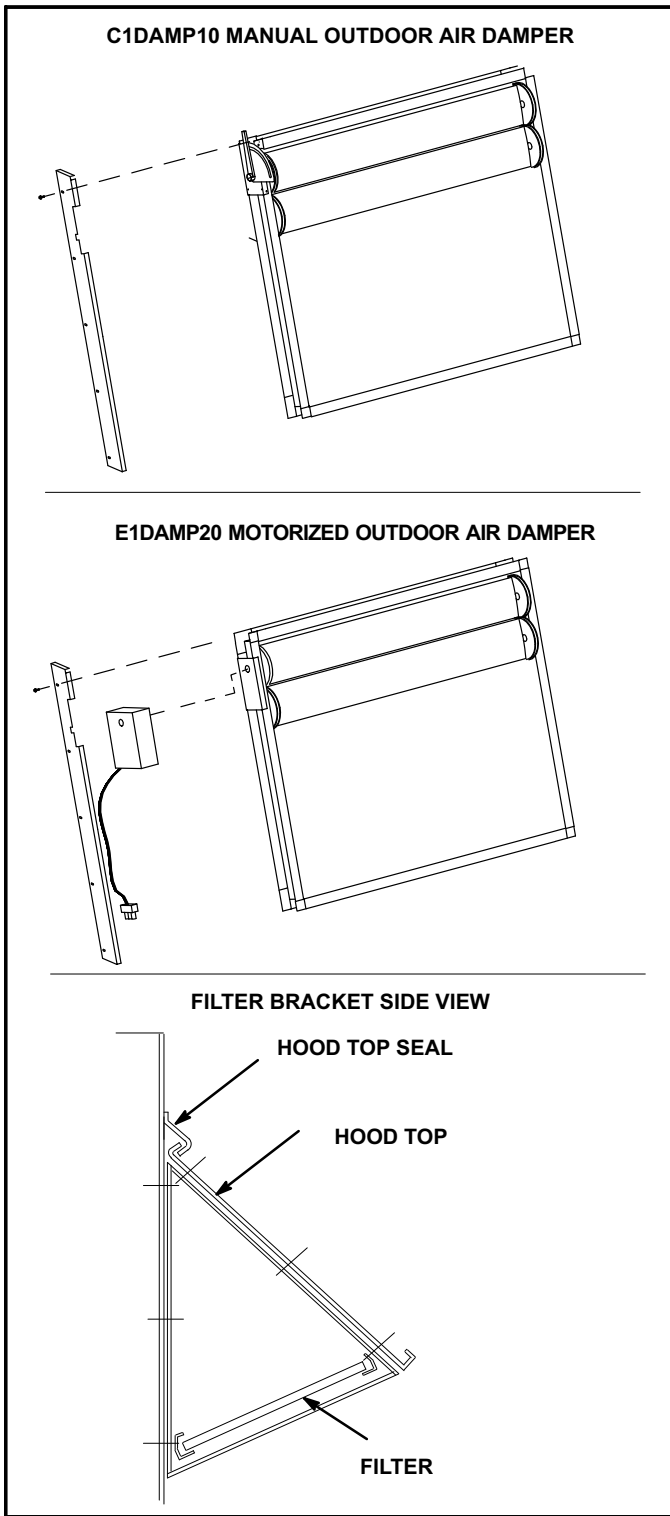

FIGURE 34

D-Supply and Return Diffusers

Optional flush mount diffuser/return FD11 and extended mount diffuser/return RTD11 are available for use with all LGH units. Refer to manufacturer's instructions included with transition for detailed installation procedures.

E-E1ECON15C-2 Standard and E1ECON17C-1 High Performance Economizer (Field or Factory Installed)

The optional economizer can be used with downflow and horizontal air discharge applications. The economizer uses outdoor air for free cooling when temperature and/or humidity is suitable. An economizer hood is furnished with the economizer.

NOTE - Gravity exhaust dampers are required with power exhaust.

The economizer is controlled by the A55 Unit Controller.

The economizer will operate in one of four modes. Each mode requires a different A55 Unit Controller DIP switch setting. Each mode also requires different sensors.

The following is a brief description. See economizer installation instruction for more detail.

1-"TMP" MODE (SENSIBLE TEMPERATURE)

In the "TMP" mode, the IMC uses input from the factory installed RT6 Supply Air Sensor, RT16 Return Air Sensor and RT17 Outdoor Air Sensor to determine suitability of outside air and economizer damper operation. When outdoor sensible temperature is less than return air sensible temperature, outdoor air is used for cooling. This may be supplemented by mechanical cooling to meet comfort demands. This application does not require additional optional sensors.

2-"ODE" MODE (OUTDOOR ENTHALPY)

The "ODE" or outdoor enthalpy mode requires a field-provided and -installed Honeywell C7400 enthalpy sensor (16K96). The sensor monitors outdoor air temperature and humidity (enthalpy). When outdoor air enthalpy is below the enthalpy control setpoint, the economizer modulates to allow outdoor air for free cooling.

3-"DIF" MODE (DIFFERENTIAL ENTHALPY)

The "DIF" or differential enthalpy mode requires two field-provided and -installed Honeywell C7400 enthalpy sensors (16K97). One sensor is installed in the outside air opening and the other sensor is installed in the return air opening. When the outdoor air enthalpy is below the return air enthalpy, the economizer opens to bring in outdoor air for free cooling.

4-"GLO" MODE (GLOBAL)

Global Mode - The "GLO" or global mode is used with an energy management system which includes a global control feature. Global control is used when multiple units (in one location) respond to a single outdoor air sensor. Each energy management system uses a specific type of outdoor sensor which is installed and wired by the controls contractor.

Motorized Outdoor Air Damper - The "GLO" mode is also used when a motorized outdoor air damper is installed in the system.

NOTE - All economizer modes of operation will modulate dampers to 55° F (13° C) supply air.

F-Gravity Exhaust Dampers

C1DAMP50C dampers (figure 35) are used in downflow and LAGEDH are used in horizontal air discharge applications. LAGEDH gravity exhaust dampers are installed in the return air plenum. The dampers must be used any time an economizer or power exhaust fans are applied to LGH series units. An exhaust hood is furnished with the gravity exhaust damper.

Gravity exhaust dampers allow exhaust air to be discharged from the system when an economizer and/or power exhaust is operating. Gravity exhaust dampers also prevent outdoor air infiltration during unit off cycle. See installation instructions for more detail.

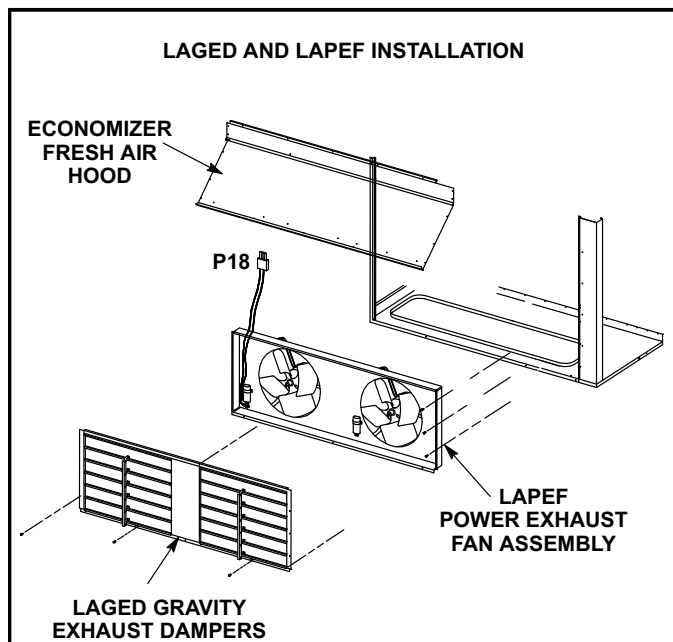

FIGURE 35

G-C1PWRE10 Power Exhaust Fans

C1PWRE10 power exhaust fans are used in downflow applications only. C1PWRE10 fans require optional downflow gravity exhaust dampers and E1ECON15 economizers. Power exhaust fans provide exhaust air pressure relief and also run when return air dampers are closed and supply air blowers are operating. Figure 35 shows the location of the power exhaust fans. See installation instructions for more detail.

H-Optional Cold Weather Kit (Canada only)

Electric heater is available to automatically control the minimum temperature in the gas burner compartment. Heater is C.G.A. certified to allow cold weather operation of unit down to -60° F (-50° C).

The kit includes the following parts:

- 1- The strip heater (HR6) is located as close as possible to the gas valve. The strip heater is rated at 500 Watts (line voltage).
- 2- A thermostat mounting box is installed on the vestibule of the heating compartment. Included in the box are the following thermostat switches:
 - a - Thermostat switch (S59) is an auto-reset SPST N.C. switch which opens on a temperature drop. The switch is wired in series with 24v power and the combustion air blower switch. When the temperature drops below -30° F (-35° C) the switch opens and the gas heat section is de-energized. The switch automatically resets when the heating compartment temperature reaches -10° F (-12° C).
 - b - Thermostat switch (S60) is an auto-reset SPST N.C. switch which opens on a temperature rise. The switch is wired in series with K125 coil. When the temperature rises above 20° F (-7° C) the switch opens and the electric heater is de-energized through K125. The switch automatically resets when the heating compartment temperature reaches -10° F (23.3° C).
 - c - Thermostat switch (S61) is an auto-reset SPST N.O. switch which closes on a temperature drop. The switch is wired in series with K125 coil. When temperature drops below 20° F (-7° C) the switch closes and electric heater is energized through K125. The switch automatically opens when heating compartment temperature reaches 76° F (24° C).

I-Control Systems

The A55 Unit Controller provides all control function for the rooftop unit. Default operation requires a standard room thermostat or direct digital controller (DDC). The A55 can also control the unit from a zone temperature sensor. The A55 Unit Controller is a network controller when daisy-chained to the L Connection® Network Control System. For ease of configuration, the A55 can be connected to a PC with Unit Controller PC software installed.

J-Smoke Detectors A171, A172, A173

Photoelectric smoke detectors are a factory- and field-installed option. The smoke detectors can be installed in the supply air section (A172), return air section (A171), or in both the supply and return air section. Smoke detection control module (A173) is located below the control panel. Wiring for the smoke detectors are shown on the temperature control section (C) wiring diagram in back of this manual.

K-Blower Proving Switch S52

The blower proving switch monitors blower operation and locks out the unit in case of blower failure. The switch is N.O. and closes at .15" W.C. (3.3 Pa) The switch is mounted on the middle left corner of the blower support panel. Wiring for the blower proving switch is shown on the temperature control section (C) wiring diagram in back of this manual.

L-Dirty Filter Switch S27

The dirty filter switch senses static pressure increase indicating a dirty filter condition. The switch is N.O. and closes at 1" W.C. (248.6 Pa) The switch is mounted on the top corner of the economizer. Wiring for the dirty filter switch is shown on the temperature control section (C) wiring diagram in back of this manual.

M-LP / Propane Kit

Units require two (one for each gas heat section) natural to LP/propane kit. The kit includes one gas valve, eleven burner orifices and three stickers. For more detail refer to the natural to LP gas changeover kit installation instructions.

N-Indoor Air Quality (CO₂) Sensor A63

The indoor air quality sensor monitors CO₂ levels and reports the levels to the A55 Unit Controller. The board adjusts the economizer dampers according to the CO₂ levels. The sensor is mounted next to the indoor thermostat or in the return air duct. Refer to the indoor air quality sensor installation instructions for proper adjustment. Wiring for the indoor air quality switch is shown on the temperature control section (C) wiring diagram in back of this manual.

O-Optional UVC Lights

The Healthy Climate® germicidal light emits ultraviolet (UVC) energy that has been proven effective in reducing microbial life forms (viruses, bacteria, yeasts and molds) in the air.

UVC germicidal lamps greatly reduce the growth and proliferation of mold and other bio-aerosols (bacteria and viruses) on illuminated surfaces.

Germicidal lamps are NOT intended to be used for removal of active mold growth. Existing mold growth must be appropriately removed PRIOR to installation of the germicidal lamp.

Refer closely to UVC light installation instruction warnings when servicing units.

P-Drain Pan Overflow Switch S149 (optional)

The overflow switch is used to interrupt cooling operation when excessive condensate collects in the drain pan.

The N.C. overflow switch is connected to the M2 Unit Controller (A55) through DI-3. When the switch opens, the Unit Controller will shut off the unit. After a five-minute time out, the Unit Controller will verify the overflow switch position and restart the unit (if the switch has closed). The Unit Controller has a three-strike counter before the unit locks out. This means the Unit Controller will allow the overflow switch to open three times per thermostat demand. If the unit locks out, a reset of the Unit Controller is required after the switch has closed to restore unit operation.

VIII-FACTORY-INSTALLED Hot Gas Re-Heat

General

Hot Gas Re-Heat units provide a dehumidifying mode of operation. These units contain a reheat coil adjacent to and downstream of the evaporator coil. Reheat coil solenoid valves, L14 and L30, route hot discharge gas from the compressor to the reheat coil. Return air pulled across the evaporator coil is cooled and dehumidified; the reheat coil adds heat to supply air.

See figure 36 for 156, 180 and 210 reheat refrigerant routing, figure 37 for 156, 180 and 210 normal cooling refrigerant routing, figure 38 for 240 and 300S reheat refrigerant routing and figure 39 for 240 and 300S normal cooling refrigerant routing.

L14 and L30 Reheat Coil Solenoid Valves

When Unit Controller (P298-5 or J299-8) indicates room conditions require dehumidification, L14 and L30 reheat valves are energized (Unit Controller P269-3 or P269-4) and refrigerant is routed to the reheat coil.

Reheat Setpoint

Reheat is factory-set to energize when indoor relative humidity rises above 60% (default). The reheat setpoint can be adjusted by changing Unit Controller *Settings - Control* menu. A setting of 100% will operate reheat from an energy management system digital output. The reheat setpoint can also be adjusted using an optional Network Control Panel (NCP).

Reheat will terminate when the indoor relative humidity falls 3% (57% default) or the digital output de-energizes. The reheat deadband can be adjusted at *Settings - Control* menu.

A91 Humidity Sensor

Relative humidity should correspond to the sensor (A91) output voltage listed in table 39. For example: if indoor air relative humidity is $80\% \pm 3\%$, the humidity sensor output should read 8.00VDC.

Check the sensor output annually for accuracy. Keep the air intake openings on the sensor clean and free of obstructions and debris.

TABLE 39

Relative Humidity (%RH \pm 3%)	Sensor Output (VDC)
20	2.00
30	3.00
40	4.00
50	5.00
60	6.00
70	7.00
80	8.00
90	9.00

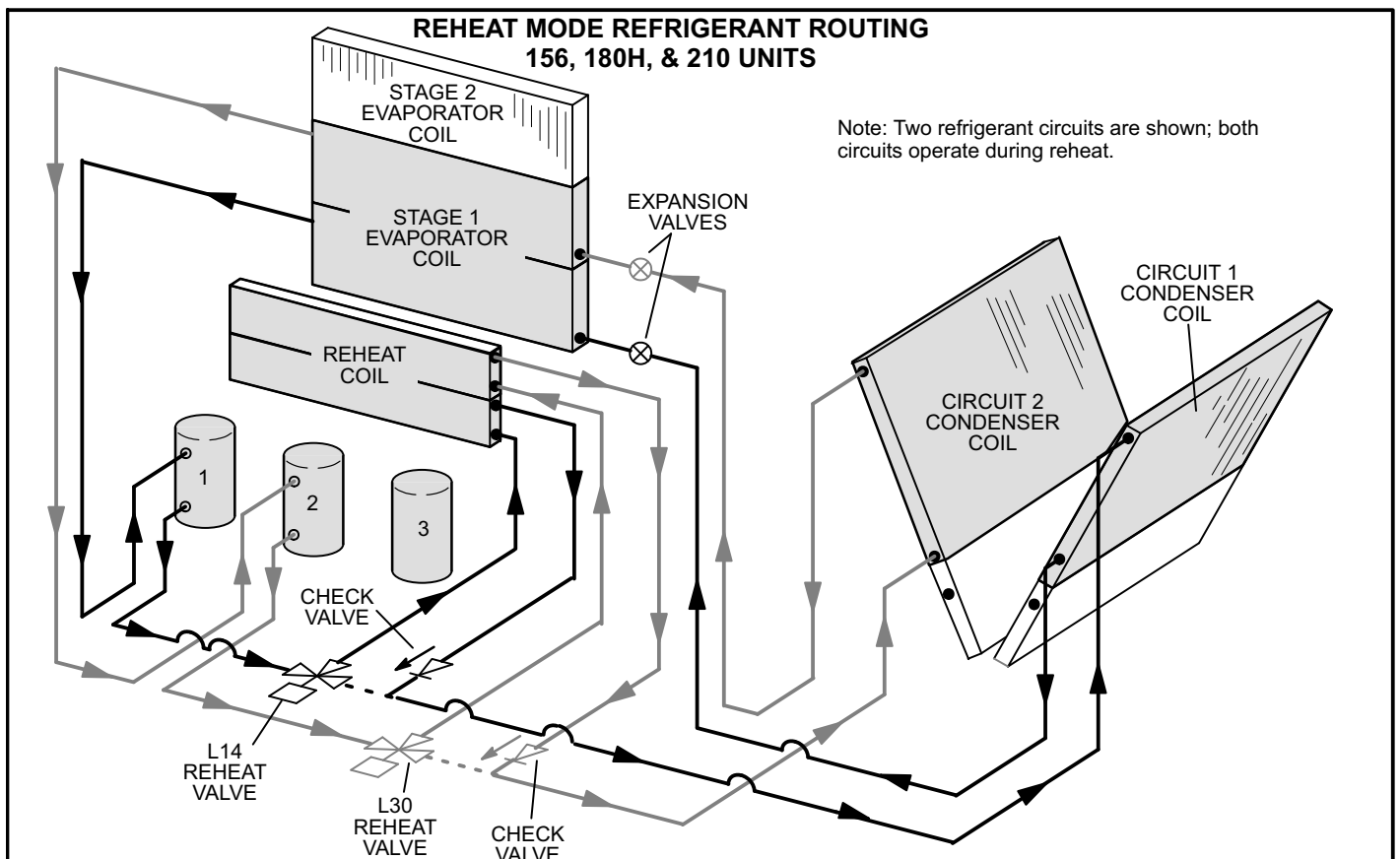

FIGURE 36

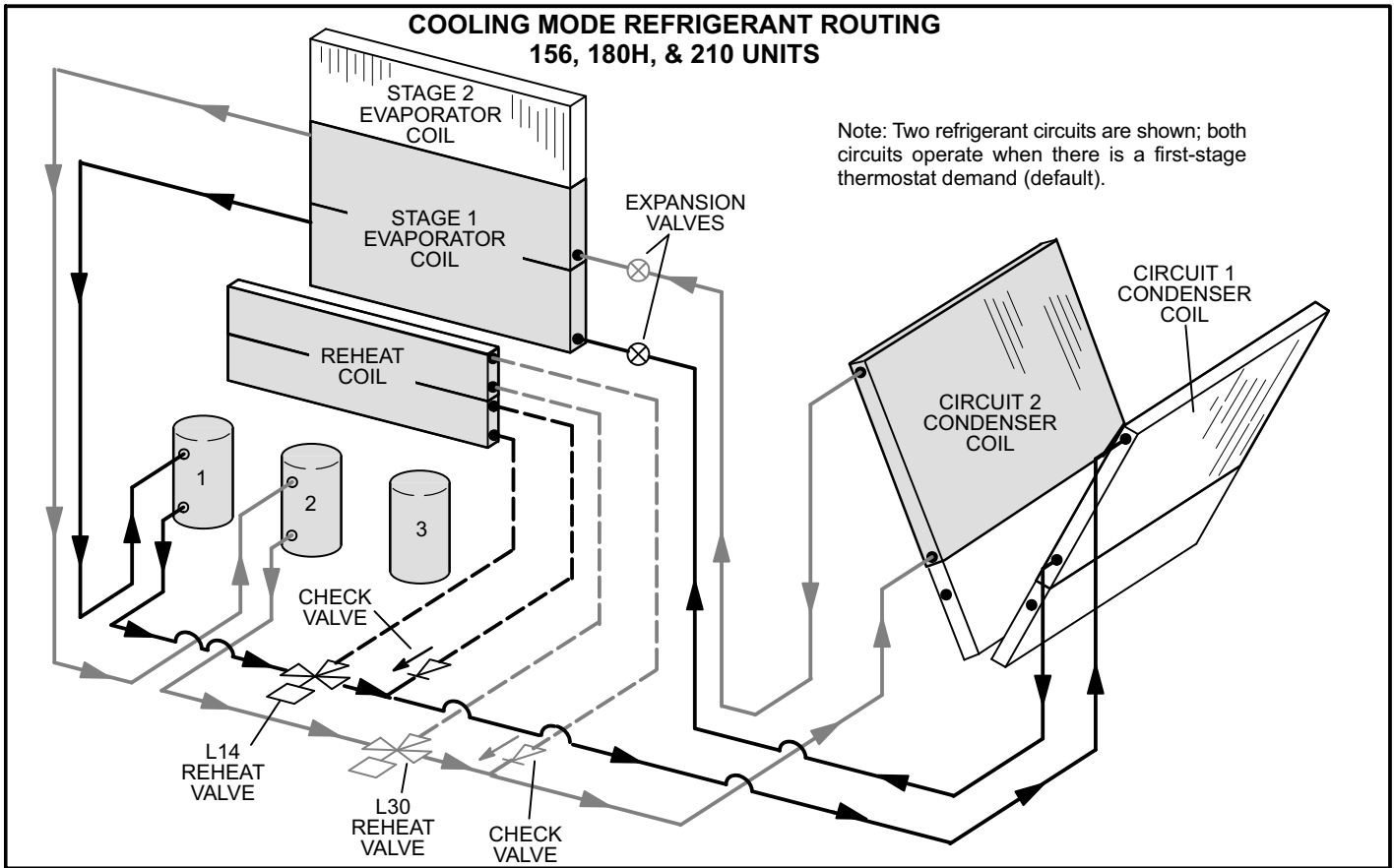

FIGURE 37

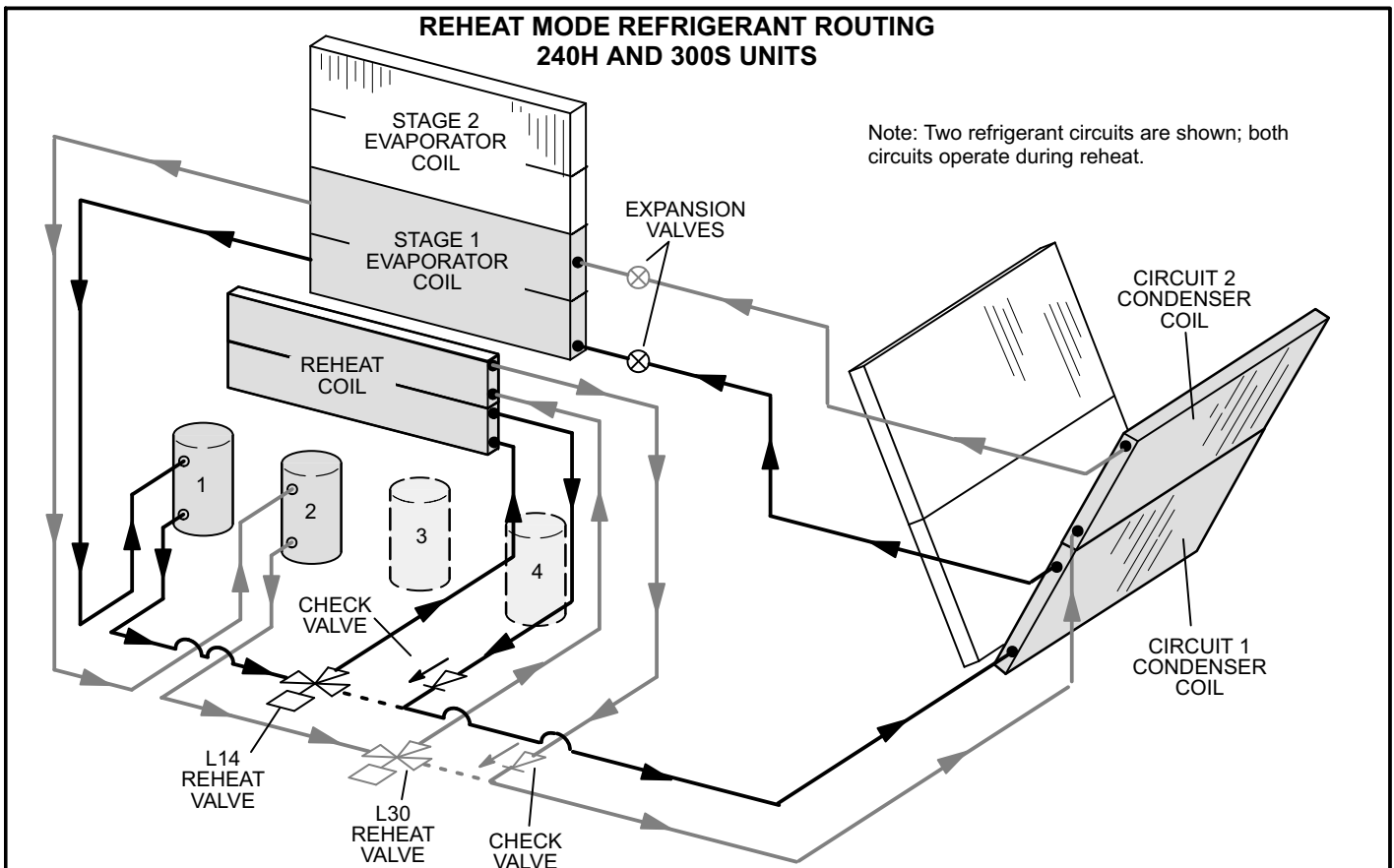

FIGURE 38

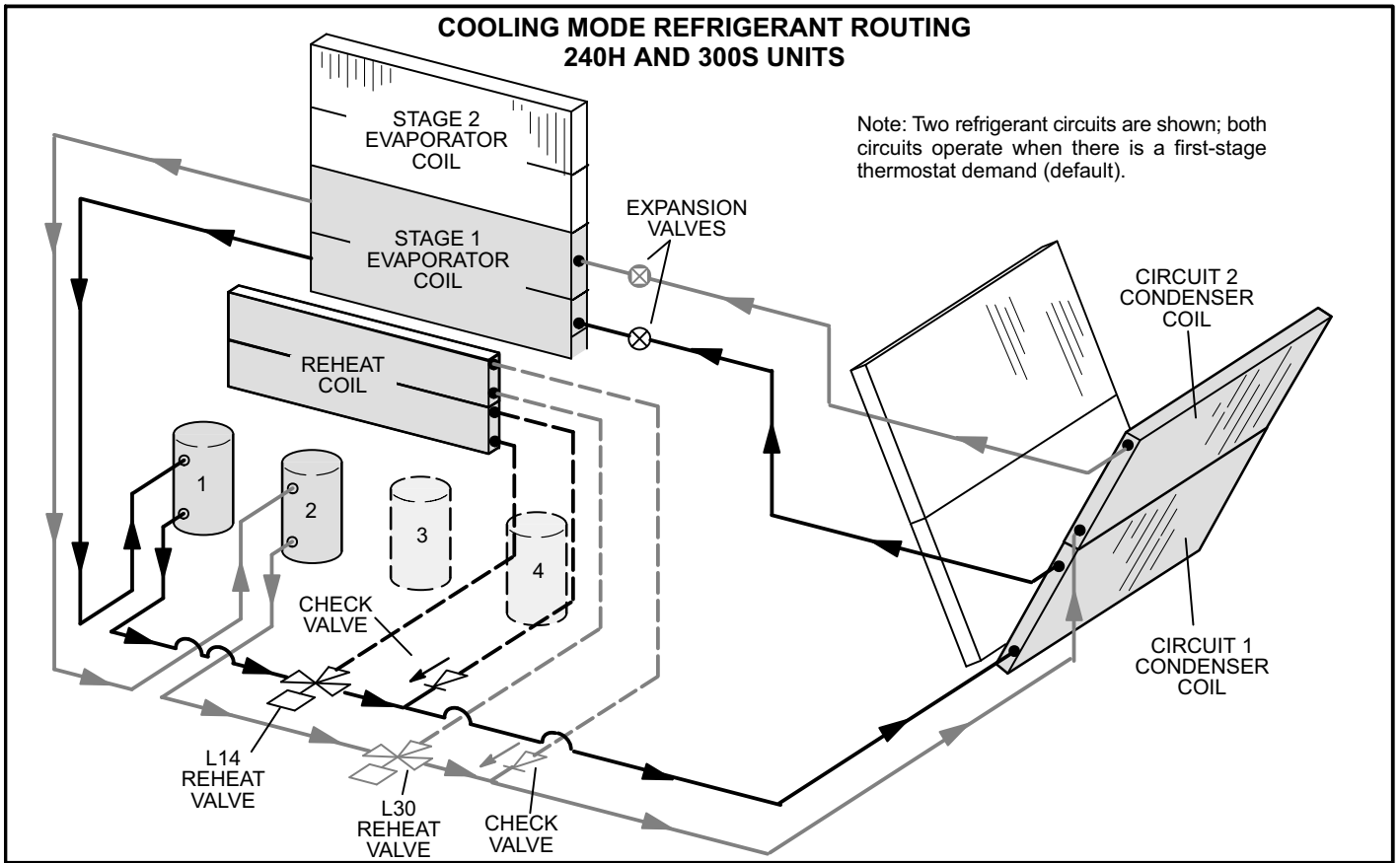

FIGURE 39

⚠ WARNING

Product contains fiberglass wool. Disturbing the insulation in this product during installation, maintenance, or repair will expose you to fiberglass wool. Breathing this may cause lung cancer. (Fiberglass wool is known to the State of California to cause cancer.) Fiberglass wool may also cause respiratory, skin and eye irritation. To reduce exposure to this substance or for further information, consult material safety data sheets available from address shown on unit nameplate or contact your supervisor.

Check-Out

Test Hot gas re-heat operation using the following procedure.

1. Make sure reheat is wired as shown in wiring section.
2. Make sure unit is in local thermostat mode.
3. Select Unit Controller *Service - Test*.

The blower, compressor 1 and compressor 2 (reheat) should be operating. Reheat mode will appear on the Unit Controller display.

4. Deselect Unit Controller *Service - Test*.

Compressor 1 and 2 (reheat) should de-energize,, blower should still be energized.

Default Reheat Operation

Reheat will operate as shown in table 40 once three conditions are met:

1. Blower must be operating.
2. System must be in occupied mode.
3. System must NOT be operating in heating mode.

IMPORTANT - Free cooling does not operate during reheat.

For other reheat control options, refer to the Unit Controller manual.

Additional Cooling Stages

Units are shipped from the factory to provide two stages of cooling.

Three stages of cooling is available in zone sensor mode. Three stages of cooling is also available by installing a transfer relay and a three-stage thermostat. Refer to the Main Control Operation section in the Unit Controller manual when using the transfer relay.

Four stages of cooling is available in zone sensor mode on units with four compressors (240, 300S).

Compressors are not de-energized when unit operation changes from cooling to reheat or from reheat to cooling. Instead, L14 and L30 reheat valves are energized (reheat) or de-energized (cooling).

NOTE - Another thermostat staging option is available which allows both compressors to be energized during free cooling. See Unit Controller manual for details.

**TABLE 40
REHEAT OPERATION**

Two-Stage Thermostat - Default		
T'stat and Humidity Demands	Operation	
	156, 180, 210 (3-Compressors)	240, 300S (4-Compressors)
Reheat Only	Compressor 1 & 2 Reheat	Compressor 1 & 2 Reheat
Reheat & Y1	Compressor 1 & 2 Reheat and Compressor 3 Cooling ¹	Compressor 1 & 2 Reheat and Compressor 3 & 4 Cooling ¹
Reheat & Y1 & Y2	Compressor 1, 2, & 3 Cooling ³	Compressor 1, 2, 3 & 4 Cooling ³
Three-Stage Thermostat (Transfer relay required)		
T'stat and Humidity Demands	Operation	
	156, 180, 210 (3-Compressors)	240, 300S (4-Compressors)
Reheat Only	Compressor 1 & 2 Reheat	Compressor 1 & 2 Reheat
Reheat & Y1	Compressor 1 & 2 Reheat and Compressor 3 Cooling ¹	Compressor 1 & 2 Reheat and Compressor 3 Cooling ¹
Reheat Y1 & Y2	Compressor 1, & 2, Cooling ²	Compressor 1 & 2 Reheat and Compressor 3, & 4 Cooling ³
Reheat Y1 & Y2 & Y3	Compressor 1, 2, & 3 Cooling ³	Compressor 1, 2, 3, & 4 Cooling ⁴
Four-Stage Zone Sensor Mode		
Cooling* and Humidity** Demands	Operation	
	156, 180, 210 (3-Compressors)	240, 300S (4-Compressors)
Reheat Only	Compressor 1 & 2 Reheat	Compressor 1 & 2 Reheat
Reheat & Y1	Compressor 1 & 2 Reheat and Compressor 3 Cooling ¹	Compressor 1 & 2 Reheat and Compressor 3 Cooling ¹
Reheat & Y1 & Y2	Compressor 1, & 2, Cooling ²	Compressor 1 & 2 Reheat and Compressor 3 & 4 Cooling ²
Reheat & Y1 & Y2 & Y3	Compressor 1, 2, & 3 Cooling ³	Compressor 1, 2, & 3 Cooling ³
Reheat & Y1 & Y2 & Y3 & Y4	Compressor 1, 2, & 3 Cooling ⁴	Compressor 1, 2, 3, & 4 Cooling ⁵

*Cooling stage is initiated when zone temperature is higher than the cooling setpoint plus the appropriate stage differential.

**Reheat demand is initiated when relative humidity is higher than relative humidity setpoint.

¹If there is no reheat demand and outdoor air is suitable, free cooling will operate.

²If there is no reheat demand and outdoor air is suitable, free cooling and compressor 1 will operate.

³If there is no reheat demand and outdoor air is suitable, free cooling and compressor 1 and 2 will operate.

⁴If there is no reheat demand and outdoor air is suitable, free cooling, compressor 1, 2 and 3 will operate.

⁵If there is no reheat demand and outdoor air is suitable, free cooling, compressor 1, 2, 3 and 4 will operate.

The following conditions must be met before reheat will be energized:
(factory-default; see Unit Controller manual for other options)

- | | |
|-------------------------------------|--|
| 1- Blower must be operating. | 3- System must NOT be operating in heating mode. |
| 2- System must be in occupied mode. | |

IX--Staged-Blower

Start-Up

A-Design Specifications

Use table 41 to fill in field-provided, design specified blower CFM for appropriate unit.

If only high and low cooling design specifications are provided, set the medium cooling CFM at the high or low cooling design spec or any CFM between.

B-Set Maximum CFM

Use table 41 to determine highest blower CFM for appropriate unit. Adjust the blower pulley to deliver that amount of CFM with only the blower operating. See *Determining Unit CFM* in the Blower Operation and Adjustment section.

TABLE 41
Blower CFM Design Specifications

Unit	TStat or Zone Control Stages	Blower Speed	Design Specified CFM
156, 180, 210	2	Htg.	
		Clg. High	
		Clg. Low	
		Ventilation	
156, 180, 210	3 or 4	Htg.	
		Clg. High	
		Clg. Med.	
		Clg. Low	
		Ventilation	
240, 300	2	Htg.	
		Clg. High	
		Clg. Low	
		Ventilation	
240, 300	3	Htg.	
		Clg. High	
		Clg. Med.	
		Clg. Low	
		Ventilation	
240, 300	4	Htg.	
		Clg. High	
		Clg. Med. High	
		Clg. Med. Low	
		Clg. Low	
		Ventilation	

*Available blower speeds vary by unit and thermostat stages.

C-Enter Design Specifications Into M2 and M3 Controller

Use the following menu to enter the blower design specified CFM into the Unit Controller. Make sure blower CFM is within limitations shown in tables 42 and 43. Refer to the Unit Controller manual provided with unit.

M2 - *Settings / Control / Guided Setup* (enter information as prompted by the Unit Controller if not already done).

M3 - *SETUP > TEST & BALANCE > BLOWER >*

Advanced Guided Setup (enter information as prompted by the Unit Controller if not already done).

Setup Equipment / Change Staged-Blower Settings? / Yes

*Blower / Heat CFM
Cooling High CFM¹
Cooling Low CFM¹
Vent CFM*

¹The Unit Controller will prompt when more cooling stages are available depending on the number of compressors and the control mode.

D-Set Damper Minimum Position

To maintain required minimum ventilation air volumes when the unit is in the occupied mode, two minimum damper positions must be set. The Unit Controller will open the dampers to “Min OCP Blwr Low” when blower CFM is BELOW a “mid-point” CFM. The Unit Controller will open the damper to “Min OCP Blwr High” when blower CFM is at or ABOVE the “mid-point” CFM.

The Unit Controller will calculate the “midpoint” CFM.

Set Minimum Position 1

Use the following menu in the Unit Controller to set “Min OCP Blwr Low” for the blower CFM below the “midpoint” CFM. When navigating into this menu, the Unit Controller will bring on the corresponding blower speed and allow damper position adjustment.

M2 - *Settings / Control / Staged-Blower / Damper / Low Speed*

M3 - *SETTINGS > RTU OPTIONS > EDIT PARAMETER > ENTER DATA ID - 9 > MIN DAMPER LOW BLOWER = X.X%*

Measure the intake air CFM. If the CFM is lower than the design specified CFM for ventilation air, use the Unit Controller to increase the damper percent open. If the CFM is higher than specified, decrease the damper percent open.

Note - Intake air CFM can also be determined using the outdoor air temperature, return air temperature and mixed air temperature. Refer to the economizer or outdoor air damper installation instructions.

Set Minimum Position 2

Use the same menu in the Unit Controller to set “Min OCP Blwr High” for the blower CFM above the “midpoint” CFM. When navigating into this menu, the Unit Controller will bring on the corresponding blower speed and allow damper position adjustment.

M2 - Settings / Control / Staged-Blower / Damper / High Speed

M3 - SETTINGS > RTU OPTIONS > DAMPER > MIN DAMPER POSITION BLOWR ON HIGH = X.X%

Measure the intake air CFM. If the CFM is lower than the design specified CFM for ventilation air, use the Unit Controller to increase the damper percent open. If the CFM is higher than specified, decrease the damper percent open.

Note - Intake air CFM can also be determined using the outdoor air temperature, return air temperature and mixed air temperature. Refer to the economizer or outdoor air damper installation instructions.

E-VFD Bypass

M2 Controller

The supply air VFD is factory-set to by-pass the VFD manually. To by-pass the VFD and operate the blower in the constant air volume mode, use the following Unit Controller menu and set to “engaged”:

Settings / Control / Staged-Blower / VFD Bypass

To configure the unit to by-pass the VFD automatically, use the following Unit Controller menu and set to “automatic”:

Settings / Install / New M2 / Staged-Blower VFD Bypass

Caution - Units not equipped with a VFD will be set to Settings / Control / Staged-Blower VFD Bypass / None. The blower motor could be damaged and/or result in product or property damage if the setting is changed to automatic or manual.

M3 Controller

The supply air inverter is factory-set to by-pass the inverter manually. To by-pass the inverter and operate the blower in the constant air volume mode, use the following Unit Controller menu and set to “engaged”:

SETTINGS > RTU OPTIONS > BLOWER > VFD BY-PASS

To configure the unit to by-pass the inverter automatically, use the following Unit Controller menu.

SETUP > INSTALL

Press SAVE until the menu reads:

CONFIGURATION ID 1

Change the 6th character position to A for automatic by-pass option.

Press SAVE

Caution - Units not equipped with an inverter will have the 6th character set to N, indicating the inverter is not by-passed. The blower motor could be damaged and/or result in product or property damage if the setting is changed to automatic or manual.

**TABLE 42
MINIMUM AND MAXIMUM CFM**

Gas Heat Minimum CFM		
Unit	Gas Heat Size	Airflow CFM
LGH156-300S	Low, Std. Med.	4500
LGH180-300S	High	5125
Electric Heat Minimum CFM		
Unit	Heat Size (kW)	Airflow CFM
LCH156	All	5200
LCH180-300S	All	6000
Cooling Minimum CFM - 220 CFM/ton		
Unit	Blower Speed	Airflow CFM
LGH/LCH156	Low, Med. Low, Med., Med. High	2860
LGH/LCH180	Low, Med. Low, Med., Med. High	3300
LGH/LCH210	Low, Med. Low, Med., Med. High	3850
LGH/LCH240	Low, Med. Low, Med., Med. High	4400
LGH/LCH300S	Low, Med. Low, Med., Med. High	5500
Cooling Minimum CFM - 280 CFM/ton		
Unit	Blower Speed	Airflow CFM
LGH/LCH156	High	3640
LGH/LCH180	High	4200
LGH/LCH210	High	4900
LGH/LCH240	High	5600
LGH/LCH300S	High	7000
Smoke and Ventilation Minimum CFM - 150 CFM/ton		
Unit	Not Applicable	Airflow CFM
LGH/LCH156	NA	1950
LGH/LCH180	NA	2250
LGH/LCH210	NA	2625
LGH/LCH240	NA	3000
LGH/LCH300S	NA	3750
Heating and Cooling Maximum CFM - 480 CFM/ton		
Unit	Blower Speed	Airflow CFM
LGH/LCH156	High	6240
LGH/LCH180	High	7200
LGH/LCH210	High	8400
LGH/LCH240	High	9600
LGH/LCH300S	High	12000

**TABLE 43
MINIMUM AND MAXIMUM CFM - 180U, 240U, 300U**

Gas Heat Minimum CFM		
Unit	Gas Heat Size	Airflow CFM
LGH180U/240U/300U	Low, Std., Med.	4500
LGH180U/240U/300U	High	5125
Electric Heat Minimum CFM		
Unit	Heat Size (kW)	Airflow CFM
LCH180U/240U/300U	All	6000
Cooling 1 Minimum CFM - 130 CFM/ton		
Unit	Blower Speed	Airflow CFM
LGH/LCH180U	Low	1950
LGH/LCH240U	Low	2600
LGH/LCH300U	Low	3250
Cooling 2 Minimum CFM - 160 CFM/ton		
Unit	Blower Speed	Airflow CFM
LGH/LCH180U	Med. Low	2400
LGH/LCH240U	Med. Low	3200
LGH/LCH300U	Med. Low	4000
Cooling 3 Minimum CFM - 190 CFM/ton		
Unit	Blower Speed	Airflow CFM
LGH/LCH180U	High	2850
LGH/LCH240U	High	3800
LGH/LCH300U	High	4750
Cooling 4 Minimum CFM - 220 CFM/ton		
Unit	Blower Speed	Airflow CFM
LGH/LCH180U	High	3300
LGH/LCH240U	High	4400
LGH/LCH300U	High	5500
Smoke and Ventilation Minimum CFM - 150 CFM/ton		
Unit	Not Applicable	Airflow CFM
LGH/LCH180U		2250
LGH/LCH240U		3000
LGH/LCH300U		3750
Heating and Cooling Maximum CFM - 480 CFM/ton		
Unit	Blower Speed	Airflow CFM
LGH/LCH180U	High	7200
LGH/LCH240U	High	9600
LGH/LCH300U	High	12000
Gas Heat Minimum CFM		
Unit	Gas Heat Size	Airflow CFM
LGH180U/240U	Low, Std., Med.	4500
LGH180U//240U	High	5125

Operation

This is a summary of cooling operation.

Note - During a dehumidification demand the blower operates at the highest speed. Free cooling is locked-out during reheat operation. Refer to reheat start-up and operation section for details.

A-Two-Stage T'Stat; 3- and 4-Compressor Units

1-Economizer With Outdoor Air Suitable

Y1 Demand -

Compressors Off
Blower Cooling Low
Dampers modulate

Y2 Demand -

Compressors Off
Blower Cooling High
Dampers Modulate

156, 180H, 210, 240H, 300S - If dampers are at maximum open for three minutes, compressor 1 and 2 are energized and blower stays on cooling high.

180U, 240U, 300U - If dampers are at maximum open for three minutes, two compressors (one from each circuit) are energized and blower stays on cooling high.

2-No Economizer or Outdoor Air Not Suitable

Y1 Demand -

First-stage Compressors On
Blower Cooling Low
Dampers Minimum Position

Y2 Demand -

All Compressors On
Blower Cooling High
Dampers Minimum Position

B-Three-Stage T'Stat, 3 and 4 Compressor Units AND Zone Sensor (4 Clg. Stages), 3-Compressor Units

1-Economizer With Outdoor Air Suitable

Three-Compressor Units:

Y1 Demand -

Compressors Off
Blower Cooling Low
Dampers Modulate

Y2 Demand -

Compressors Off
Blower Cooling High
Dampers Modulate

Note - If dampers are at maximum open for three minutes, compressor 1 is energized and blower stays on cooling high.

Y3 Demand -

Compressors 1 and 2 On
Blower Cooling High
Dampers Maximum Open

Y4 Demand -

All Compressors On
Blower Cooling High
Dampers Maximum Open

Four-Compressor Units:

Y1 Demand -

Compressors Off
Blower Cooling Low
Dampers modulate

Y2 Demand -

Compressors Off
Blower Cooling High
Dampers Modulate

156, 180H, 210, 240H, 300S - If dampers are at maximum open for three minutes, compressors 1 and 2 are energized and blower stays on cooling high.

180U, 240U, 300U - If dampers are at maximum open for three minutes, two compressors (one from each circuit) are energized and blower stays on cooling high.

Y3 Demand -

Compressors 1, 2 and 3 On
180U, 240U, 300U, any three compressors are on
Blower Cooling High
Dampers Maximum Open

2-No Economizer or Outdoor Air Not Suitable

Three-Compressor Units:

Y1 Demand -

Compressor 1 On
Blower Cooling Low

Y2 Demand -

Compressors 1 and 2 On
Blower Cooling Medium

Y3 or Y4 Demand -

All Compressors On
Blower Cooling High

Four-Compressor Units:

Y1 Demand -

Compressors 1 and 2 On
180U, 240U - Two Compressors On
(one from each circuit)
Blower Cooling Low

Y2 Demand -

Compressors 1, 2 and 3 On
180U, 240U, 300U any three compressors are On
Blower Cooling Medium

Y3 Demand -

All Compressors On
Blower Cooling High

C-Zone Sensor (4 Clg. Stages), 4-Compressor Units

1-Economizer With Outdoor Air Suitable

Y1 Demand -

Compressors Off
Blower Cooling Low
Dampers modulate

Y2 Demand -

Compressors Off
Blower Cooling High
Dampers Modulate

156, 180H, 210, 240H, 300S - If dampers are at maximum open for three minutes, compressor 1 is energized and blower stays on cooling high.

180U, 240U, 300U - If dampers are at maximum open for three minutes, two compressors (one from each circuit) are energized and blower stays on cooling high.

Y3 Demand -

Compressors 1 and 2 On
180U, 240U, 300U - Two Compressors On
(one from each circuit)
Blower Cooling High
Dampers Maximum Open

Y4 Demand -

All Compressors On
Blower Cooling High
Dampers Maximum Open

2-No Economizer or Outdoor Air Not Suitable

Y1 Demand -

Compressor 1 On
180U, 240U, 300U - Two Compressors On
(one from each circuit)
Blower Cooling Low

Y2 Demand -

Compressors 1 and 2 On
180U, 240U, 300U - Two Compressors On
(one from each circuit)
Blower Cooling Medium Low

Y3 Demand -

Compressors 1, 2 and 3 On
180U, 240U, 300U, any three compressors are On
Blower Cooling Medium High

Y4 Demand -

All Compressors On
Blower Cooling High

X--VAV System

NOTE - Units equipped a Variable Frequency Drive (VFD) are designed to operate on balanced, three-phase power. Operating units on unbalanced three-phase power will reduce the reliability of all electrical components in the unit. Unbalanced power is a result of the power delivery system supplied by the local utility company. Factory-installed inverters are sized to drive blower motors with an equivalent current rating using balanced three-phase power. If unbalanced three-phase power is supplied; the installer must replace the existing factory-installed inverter with an inverter that has a higher current rating to allow for the imbalance.

Refer to the installation instructions for additional information and available replacements.

Units may contain an optional supply air blower equipped with a variable frequency drive A96 (VFD) which varies supply air CFM.

The supply air VFD (A96) is located near the compressors. See figure 2.

A-Start-Up

1. A pressure transducer (A30) is shipped in a box in the blower compartment. Install the transducer according to manufacturer's instructions.

Note - Make sure the transducer is installed in the main duct at least 2/3 of the distance away from the unit.

2. Two twisted pairs of shielded cable must be used to connect the pressure transducer. See figure 1. J/P300 connector is hanging in the control box.

3. Open all zone dampers and/or boxes.

4. Locate the A55 Unit Controller. Refer to figure 2.

5. Use the Unit Controller to calibrate the blower CFM. Select the **SETUP->TEST & BALANCE->BLOWER** menu to start the blower. The Unit Controller will display the percent of blower speed. Adjust blower speed percentage to meet design airflow specifications. Allow blower speed to stabilize.

6. Press SAVE to display the current static pressure. If the static pressure meets the design specification, press SAVE again to set the setpoint. If the static pressure does not meet the design specification, adjust the pressure and press SAVE to set the setpoint.

7. Record new setpoints in table 1.

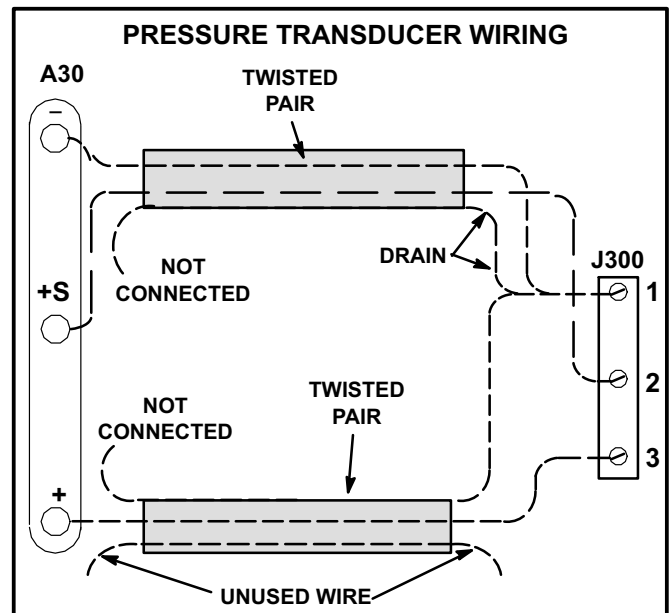

FIGURE 1

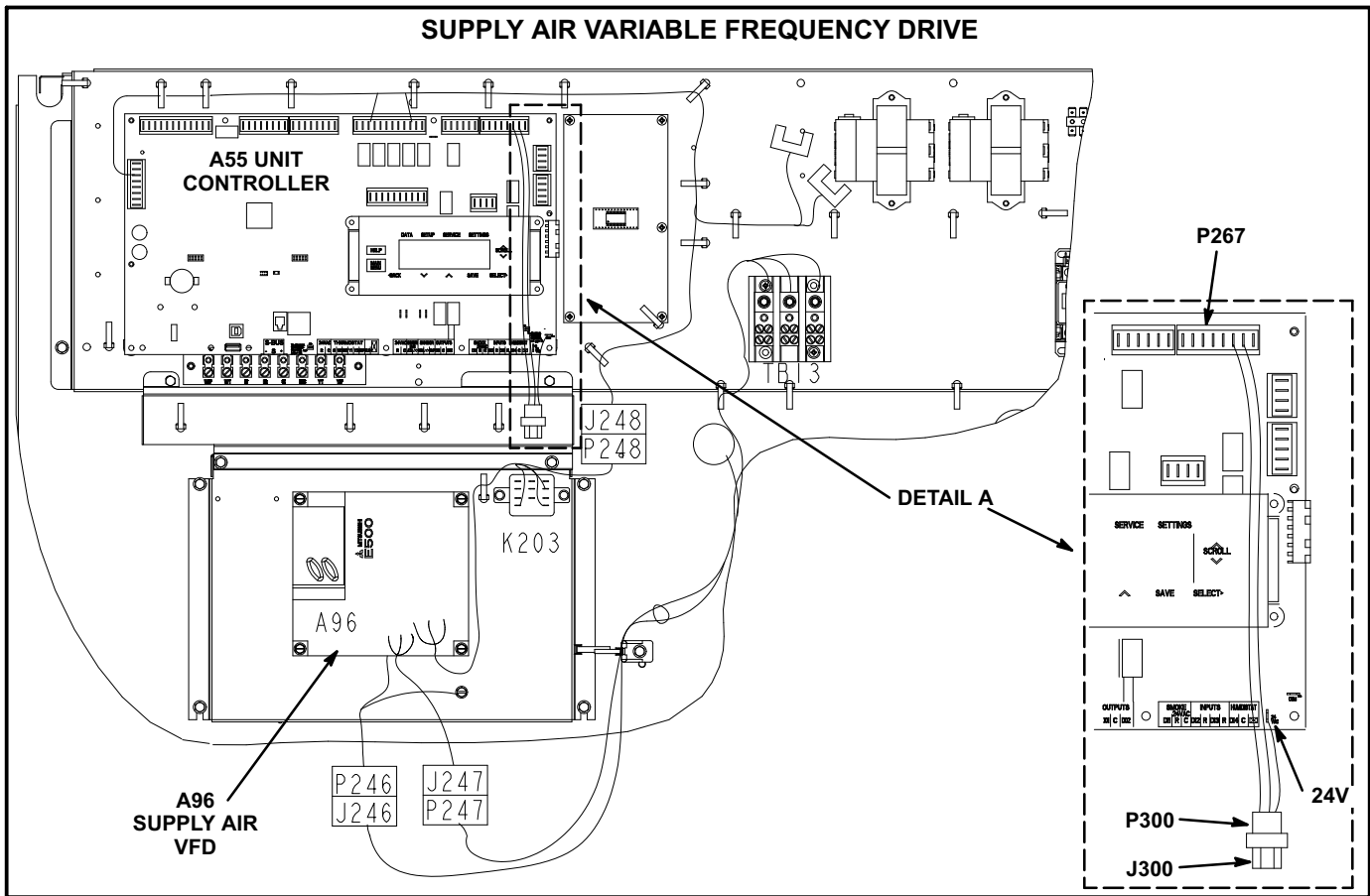

FIGURE 2

Note - The Unit Controller will lock-out the unit for 5 minutes if static pressure exceeds 2.0" w.c. for 20 seconds. The Unit Controller will permanently shut down the unit after three occurrences. See Unit Controller parameters 110, 42, and 43 to adjust default values.

8. If the desired CFM cannot be met with current pulley setup, refer to the *Blower Operation and Adjustments* section to adjust CFM.

B-Unit Operation

Use the Unit Controller to check unit mechanical operation. See the *Service - Test* section of the Unit Controller manual.

**TABLE 1
RECORD ADJUSTED SETPOINTS**

Parameter	Setpoint Description	Setpoint "w.c.	Display Setting
386	Smoke		
387	Ventilation		
388	Heating		
389	Cooling		

C-Supply Air VFD Bypass (Optional)

IMPORTANT - All dampers must be open to prevent damage to duct work and dampers.

1. Turn off all power to unit.

2. Locate J/P247 and J/P248 connectors near the VFD. See figure 3.
3. Disconnect P247 from J247 and connect J249 to P247. See figure 4.
4. Disconnect J248 from P248 and connect connect P248 jumper plug to J248. P248 jumper plug is attached to the J248 wire harness near the J248 jack connector. See figure 5.
5. Locate VFD control relay K203 on the lower control panel next to terminal strip TB24. See figure 3.
6. Locate wires labeled K203-A and K203-B in area shown in figure 3. Disconnect insulated terminals.
7. Locate wires labeled K3-A and K3-B coming from K3 blower relay. Connect to K203-A to K3-A and K203-B to K3-B.
8. Restore power to unit. Blower will operate in constant air volume (CAV) mode.
9. Check the indoor blower motor nameplate for full load amperage (FLA) value. Measure the amp readings from the indoor blower motor operating in bypass mode. If measured amps are higher than nameplate FLA value, decrease the CFM by opening (turning counterclockwise) the motor pulley. See figure 10. Do not exceed minimum and maximum number of pulley turns as shown in table 5.

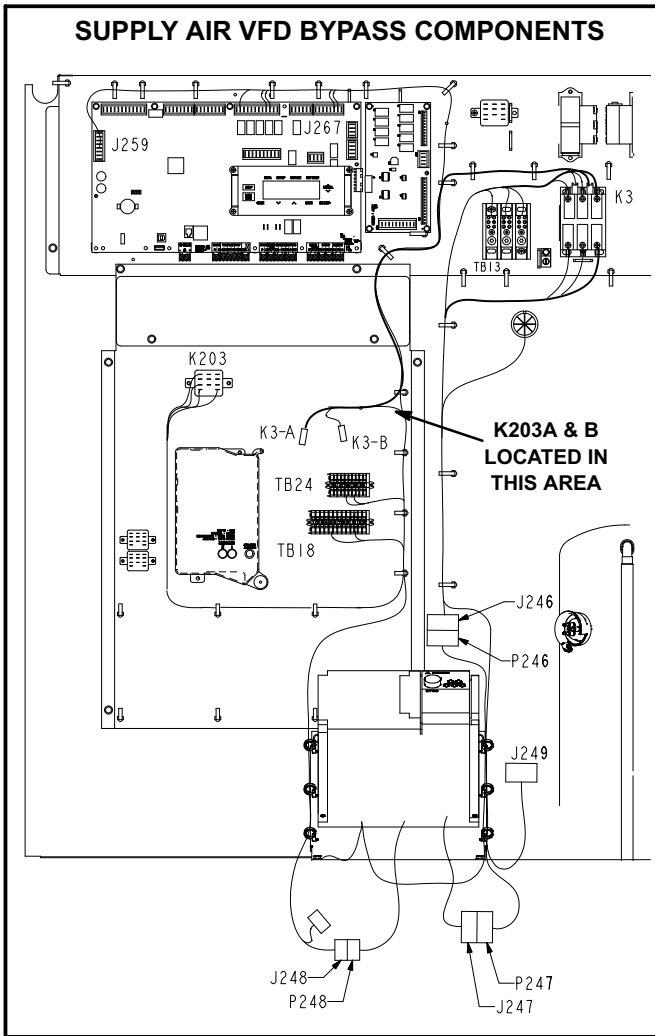

FIGURE 3

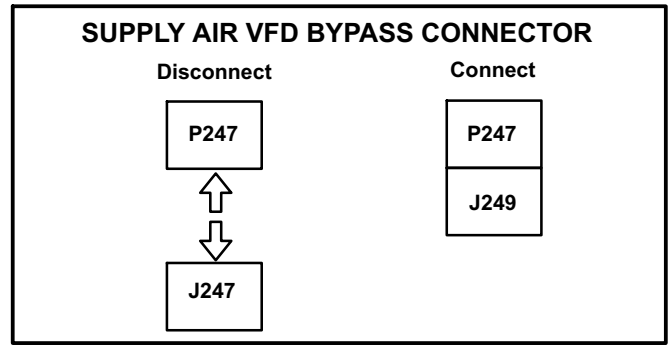

FIGURE 4

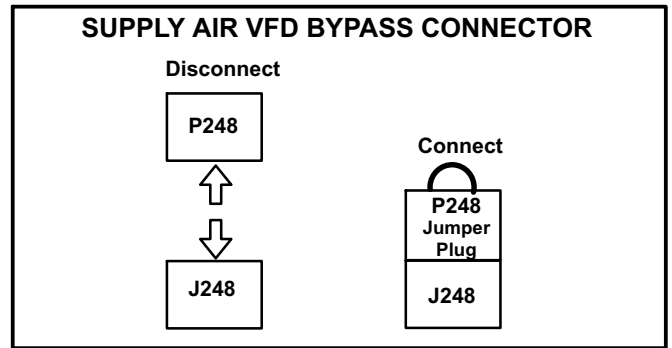

FIGURE 5

LGH156 UNIT DIAGRAM

- △ S42 USED ON "M" VOLTAGE UNITS AND UNITS WITH HIGH EFFICIENCY MOTORS
- △ ONLY USED IN UNIT WITH HUMIDITROL OPTION
- △ EXTERNAL HUMIDITROL CONTACTS
- △ S49, S50 AND S53 ARE PART OF 5VDC CIRCUIT
- △ S5, S8, S31 USED ON UNITS WITH INTERLINK COMPRESSORS ONLY
- △ B10 AND B11 NOT USED ON UNITS WITH ERV
- △ USED ON LCH AND UNITS WITH ERV SINGLE POINT POWER. SEE ERV DIAGRAM
- △ USED ON UNITS WITH ERV SINGLE POINT POWER
- △ F6 USED ON Y-VOLT UNITS AND ALL SCOR OPTION UNITS WITH POWER EXHAUST
- △ REFER TO UNIT DIAGRAM SECTION B3 WHEN INVERTER IS USED
- △ NOTE: FOR USE WITH COPPER CONDUCTORS ONLY. REFER TO UNIT RATING PLATE FOR MINIMUM CIRCUIT AMPACITY AND MAXIMUM OVERCURRENT PROTECTION SIZE.
- △ F10 USED ON UNITS WITH SCOR OPTION. F61 USED ON LGH UNITS WITH SCOR OPTION
- △ CB10 NOT AVAILABLE ON UNITS WITH SCOR OPTION
- △ MOVE WIRE FROM 240 TO 208 TAP ON TRANSFORMER FOR 208 VOLT APPLICATIONS

— DENOTES OPTIONAL COMPONENTS
 — LINE VOLTAGE FIELD INSTALLED

2018/08	537700-03	10/18
DIAGRAM		
COOLING		
LCH/LGH - 156 - G, J, M, Y		
SECTION B		
Supersedes	New Form No.	REV. 0
537700-02	537700-03	

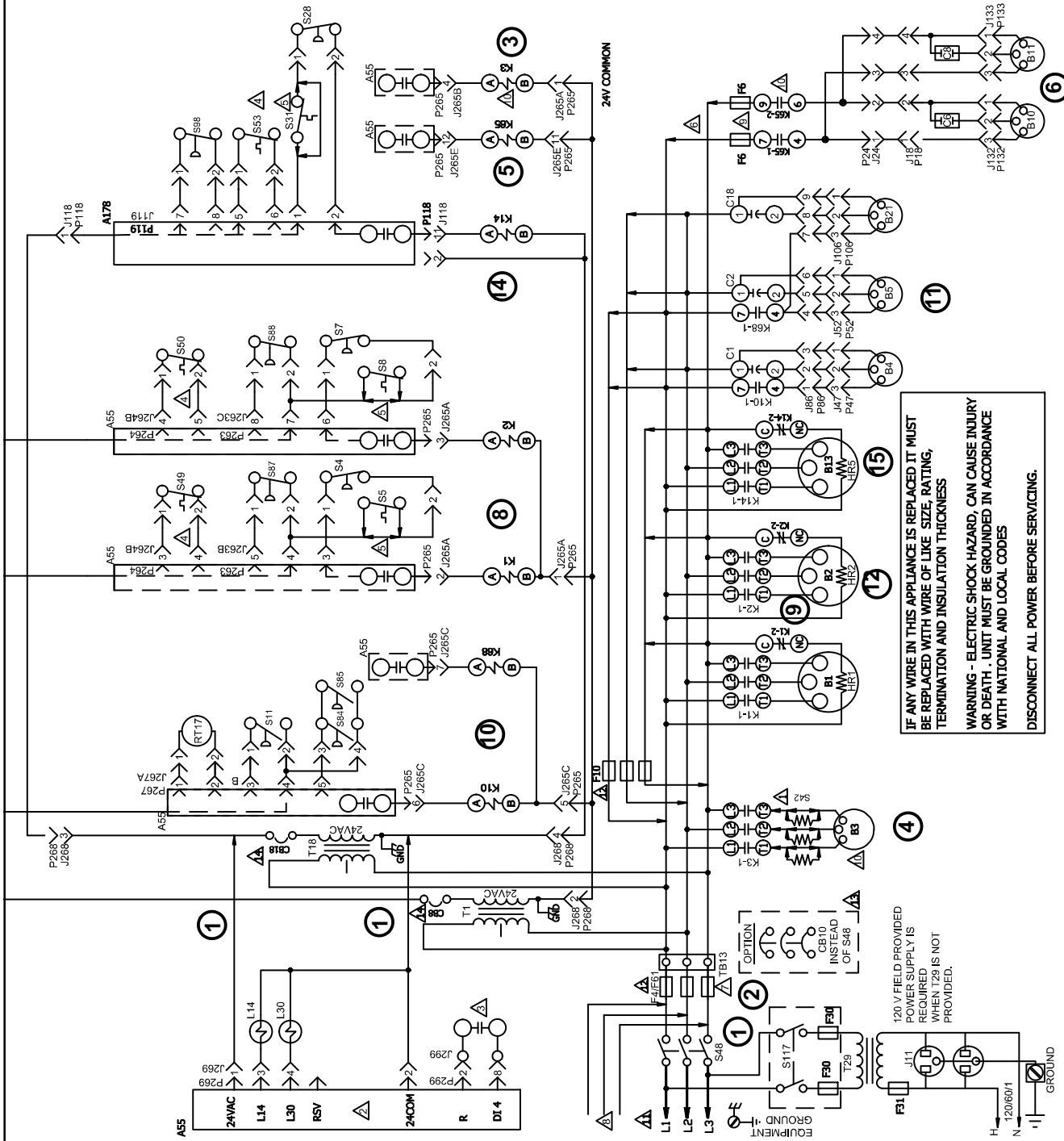

LGH156 DIAGRAM KEY DESCRIPTION

KEY	COMPONENT
A55	PANEL, MAIN BOARD LENNOX
A178	PANEL, COMP 3 & 4 AND 2ND STAGE HEAT - C3
B1	COMPRESSOR 1
B2	COMPRESSOR 2
B3	MOTOR, BLOWER
B4	MOTOR, OUTDOOR FAN 1
B5	MOTOR, OUTDOOR FAN 2
B10	MOTOR, EXHAUST FAN 1
B11	MOTOR, EXHAUST FAN 2
B13	COMPRESSOR 3
B21	MOTOR, OUTDOOR FAN 3
C1	CAPACITOR, OUTDOOR FAN 1
C2	CAPACITOR, OUTDOOR FAN 2
C6	CAPACITOR, EXHAUST FAN 1
C8	CAPACITOR, EXHAUST FAN 2
C18	CAPACITOR, OUTDOOR FAN 3
CB8	CIRCUIT, BREAKER T1
CB10	CIRCUIT BREAKER, MAIN DISCONNECT UNIT
CB18	CIRCUIT, BREAKER T18
F4	FUSE, MAIN UNIT
F6	FUSE, EXHAUST FAN
F10	FUSE, OUTDOOR FAN MOTOR
F30	FUSE, TRANSFORMER T29 PRIMARY
F31	FUSE, TRANSFORMER T29 SECONDARY
F61	FUSE, UNIT SCCR OPTION
HR1	HEATER COMPRESSOR 1
HR2	HEATER COMPRESSOR 2
HR5	HEATER COMPRESSOR 3
J11	JACK, GFI, RECEPTACLE
K1, -1	CONTACTOR, COMPRESSOR 1
K2, -1	CONTACTOR, COMPRESSOR 2
K3, -1	CONTACTOR, BLOWER
K10,-1,2	RELAY, OUTDOOR FAN 1
K14	CONTACTOR, COMPRESSOR 3
K65 - 1,2	RELAY, EXHAUST FAN
K68,-1	RELAY, OUTDOOR FAN 2
L14	VALVE, SOLENOID REHEAT VALVE 1
L30	VALVE, SOLENOID REHEAT VALVE 2
RT17	SENSOR, OUTDOOR AIR
S4	SWITCH, LIMIT HI PRESS COMPRESSOR 1
S5	SWITCH, LIMIT TEMP COMPRESSOR 1
S7	SWITCH, LIMIT HI PRESS COMPRESSOR 2
S8	SWITCH, LIMIT HI TEMP COMPRESSOR 2
S11	SWITCH, LOW PRESS, LOW AMBIENT COMP 1
S28	SWITCH, LIMIT HI PRESS COMPRESSOR 3
S31	SWITCH, LIMIT HI TEMP COMPRESSOR 3
S42	SWITCH, OVERLOAD RELAY BLOWER MOTOR
S48	SWITCH, DISCONNECT
S49	SWITCH, FREEZE STAT COMPRESS 1
S50	SWITCH, FREEZE STAT COMPRESS 2
S53	SWITCH, FREEZE STAT COMPRESS 3
S84	SWITCH, LOW PRESS, LOW AMBIENT COMP 2
S85	SWITCH, LOW PRESS, LOW AMBIENT COMP 3
S87	SWITCH, LOW PRESS, COMP 1
S88	SWITCH, LOW PRESS, COMP 2
S98	SWITCH, LOW PRESS, COMP 3
S117	SWITCH, GFI
T1	TRANSFORMER, CONTROL
T18	TRANSFORMER, CONTACTOR
T29	TRANSFORMER, GFI
TB13	TERMINAL STRIP, POWER DISTRIBUTION

J/P	JACK/PLUG DESCRIPTION
18	EXHAUST FAN COMP
24	EXHAUST FAN
47	OUTDOOR FAN 1
52	OUTDOOR FAN 2
86	OUTDOOR FAN INTERFACE
106	OUTDOOR FAN 3
118	COMPRESSOR 3 AND 4, CONTROL
119	COMPRESSOR 3 AND 4, INPUT
132	EXHAUST FAN MOTOR 1
133	EXHAUST FAN MOTOR 2
263	HIGH AND LOW PRESSURE SWITCHES
264	BLOWER DECK
265	CONTACTORS AND RELAYS
267	OUTDOOR FAN AREA
268	TRANSFORMER POWER
269	REHEAT CONTROL
299	HUMIDITROL SAFETY INTERFACE

LGH180 UNIT DIAGRAM

- ▲ 542 USED ON "M" VOLTAGE UNITS
- ▲ ONLY IN UNITS WITH HUMIDITROL OPTION
- ▲ EXTERNAL HUMIDITROL CONTACTS
- ▲ S49 AND S50 ARE PART OF 5VDC CIRCUIT
- ▲ S5, S8, S31 USED ON UNITS WITH INTERLINK COMPRESSORS ONLY
- ▲ B10 AND B11 NOT USED ON UNITS WITH ERV
- ▲ USED ON LCH AND UNITS WITH ERV SINGLE POINT POWER. SEE ERV DIAGRAM
- ▲ USED ON UNITS WITH ERV SINGLE POINT POWER
- ▲ F6 USED ON Y-VOLT UNITS WITH FIELD INSTALLED POWER EXHAUST
- ▲ REFER TO UNIT DIAGRAM SECTION B3 WHEN INVERTER IS USED
- ▲ NOTE: FOR USE WITH COPPER CONDUCTORS ONLY. REFER TO UNIT RATING PLATE FOR MINIMUM CIRCUIT AMPACITY AND MAXIMUM OVERCURRENT PROTECTION SIZE.
- ▲ F10 USED ON UNITS WITH SCCR OPTION. F61 USED ON LGH UNITS WITH SCCR OPTION
- ▲ CB10 NOT AVAILABLE ON UNITS WITH SCCR OPTION
- ▲ MOVE WIRE FROM 240 TO 208 TAP ON TRANSFORMER FOR 208 VOLT APPLICATIONS
- ▲ DENOTES OPTIONAL COMPONENTS
- LINE VOLTAGE FIELD INSTALLED

WIRING DIAGRAM	09/18
537701-03	
COOLING	
LCH, LGH 180 - G, J, M, Y	
SECTION B	
New Form No.	REV. 0
Supersedes	537701-02

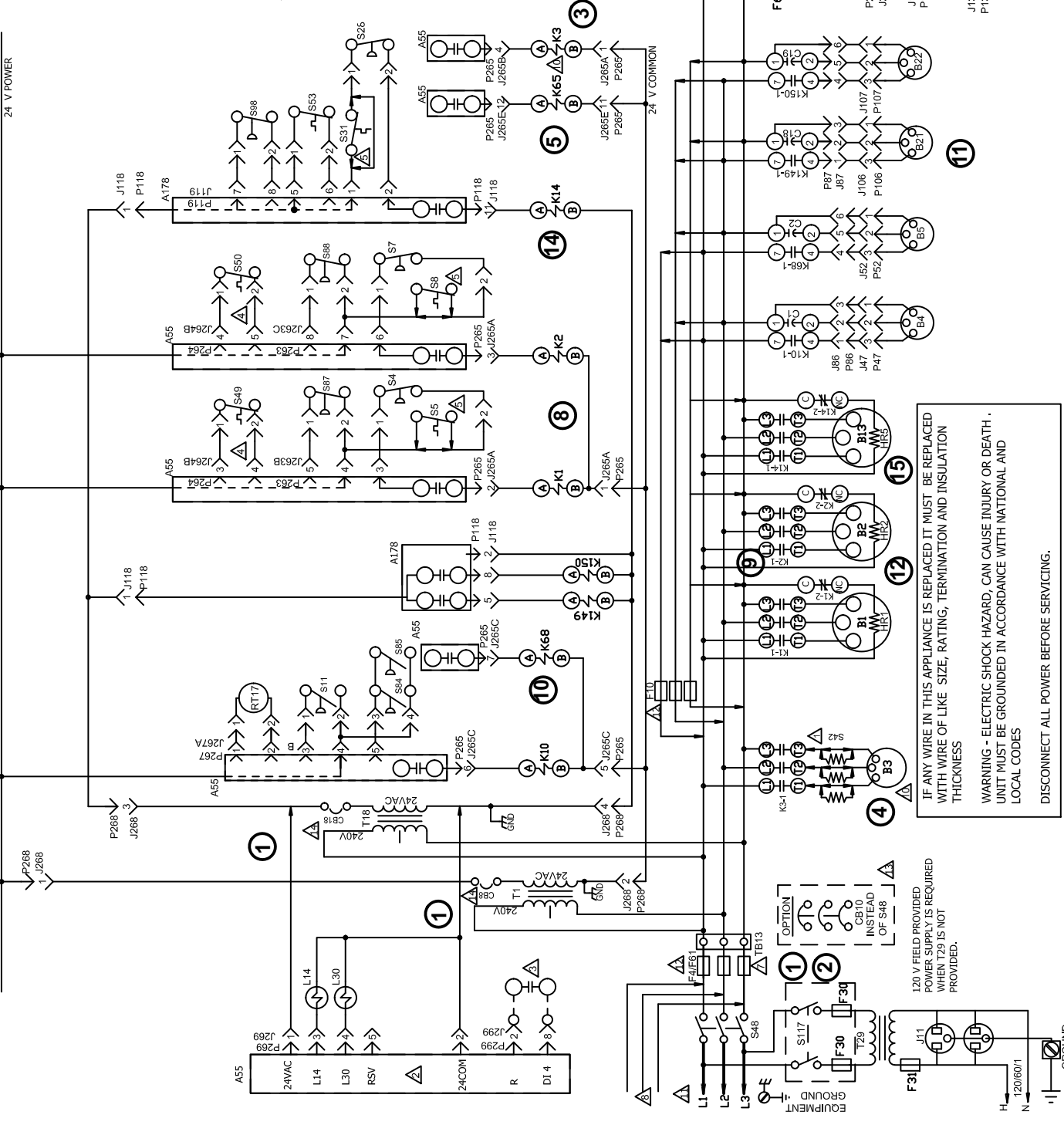

IF ANY WIRE IN THIS APPLIANCE IS REPLACED IT MUST BE REPLACED WITH WIRE OF LIKE SIZE, RATING, TERMINATION AND INSULATION THICKNESS

WARNING - ELECTRIC SHOCK HAZARD. CAN CAUSE INJURY OR DEATH. UNIT MUST BE GROUND IN ACCORDANCE WITH NATIONAL AND LOCAL CODES

DISCONNECT ALL POWER BEFORE SERVICING.

120 V FIELD PROVIDED POWER SUPPLY IS REQUIRED WHEN T29 IS NOT PROVIDED.

LGH180 KEY DESCRIPTION

KEY	COMPONENT
A55	PANEL, MAIN
A178	PANEL, COMP 3 & 4 AND 2ND STAGE HEAT - C3
B1	COMPRESSOR 1
B2	COMPRESSOR 2
B3	MOTOR, BLOWER
B4	MOTOR, OUTDOOR FAN 1
B5	MOTOR, OUTDOOR FAN 2
B10	MOTOR, EXHAUST FAN 1
B11	MOTOR, EXHAUST FAN 2
B13	COMPRESSOR 3
B21	MOTOR, OUTDOOR FAN 3
B22	MOTOR, OUTDOOR FAN 4
C1	CAPACITOR, OUTDOOR FAN 1
C2	CAPACITOR, OUTDOOR FAN 2
C6	CAPACITOR, EXHAUST FAN 1
C8	CAPACITOR, EXHAUST FAN 2
C18	CAPACITOR, OUTDOOR FAN 3
C19	CAPACITOR, OUTDOOR FAN 4
CB8	CIRCUIT, BREAKER T1
CB10	CIRCUIT BREAKER, MAIN DISCONNECT UNIT
CB18	CIRCUIT, BREAKER T18
F4	FUSE, MAIN UNIT
F6	FUSE, EXHAUST FAN
F10	FUSE, OUTDOOR FAN MOTOR
F30	FUSE, TRANSFORMER T29 PRIMARY
F31	FUSE, TRANSFORMER T29 SECONDARY
F61	FUSE, UNIT SCOR OPTION
HR1	HEATER COMPRESSOR 1
HR2	HEATER COMPRESSOR 2
HR5	HEATER COMPRESSOR 3
J11	JACK, GFI, RECEPTACLE
K1,-1	CONTACTOR, COMPRESSOR 1
K2,-1	CONTACTOR, COMPRESSOR 2
K3,-1	CONTACTOR, BLOWER
K10,-1	RELAY, OUTDOOR FAN 1
K14,-1	CONTACTOR, COMPRESSOR 3
K65,-1,2	RELAY, EXHAUST FAN
K68,-1	RELAY, OUTDOOR FAN 2
K149,-1	RELAY, OUTDOOR FAN 3
K150,-1	RELAY, OUTDOOR FAN 4
L14	VALVE, SOLENOID REHEAT VALVE 1
L30	VALVE, SOLENOID REHEAT VALVE 2
RT17	SENSOR, OUTDOOR AIR
S4	SWITCH, LIMIT HI PRESS COMPRESS 1
S5	SWITCH, LIMIT HI TEMP COMPRESSOR 1
S7	SWITCH, LIMIT HI PRESS COMPRESS 2
S8	SWITCH, LIMIT HI TEMP COMPRESSOR 2
S11	SWITCH, LOW PRESS, LOW AMBIENT COMP 1
S28	SWITCH, LIMIT HI PRESS COMPRESS 3
S31	SWITCH, LIMIT HI TEMP COMPRESSOR 3
S42	SWITCH, OVERLOAD RELAY BLOWER MOTOR

S48	SWITCH, DISCONNECT
S49	SWITCH, FREEZE STAT COMPRESS 1
S50	SWITCH, FREEZE STAT COMPRESS 2
S53	SWITCH, FREEZE STAT COMPRESS 3
S84	SWITCH, LOW PRESS, LOW AMBIENT COMP 2
S85	SWITCH, LOW PRESS, LOW AMBIENT COMP 3
S87	SWITCH, LOW PRESS, COMP 1
S88	SWITCH, LOW PRESS, COMP 2
S98	SWITCH, LOW PRESS, COMP 3
S117	SWITCH, GFI
T1	TRANSFORMER, CONTROL
T18	TRANSFORMER, CONTACTOR
T29	TRANSFORMER, GFI
TB13	TERMINAL STRIP, POWER DISTRIBUTION

J/P	JACK/PLUG DESCRIPTION
18	EXHAUST FAN COMP
24	EXHAUST FAN
47	OUTDOOR FAN 1
52	OUTDOOR FAN 2
86	OUTDOOR FAN INTERFACE 1
87	OUTDOOR FAN INTERFACE 2
106	OUTDOOR FAN 3
107	OUTDOOR FAN 4
118	COMPRESSOR 3 AND 4, CONTROL
119	COMPRESSOR 3 AND 4, INPUT
132	EXHAUST FAN MOTOR 1
133	EXHAUST FAN MOTOR 2
263	HIGH AND LOW PRESSURE SWITCHES
264	BLOWER DECK
265	CONTACTORS AND RELAYS
267	OUTDOOR FAN AREA
268	TRANSFORMER POWER
269	REHEAT CONTROL
299	HUMIDITROL INTERFACE/SAFETY

LGH210 UNIT DIAGRAM

- △ S42 USED ON "M" VOLTAGE UNITS
- △ ONLY IN UNITS WITH HUMIDITROL OPTION
- △ EXTERNAL HUMIDITROL CONTACTS
- △ S49 AND S50 ARE PART OF 5VDC CIRCUIT COMPRESSORS ONLY
- △ S5, S8, S31 USED ON UNITS WITH INTERLINK
- △ B10, B11 NOT USED ON UNITS WITH ERV
- △ USED ON LCH AND UNITS WITH ERV SINGLE POINT POWER. SEE ERV DIAGRAM
- △ USED ON UNITS WITH ERV SINGLE POINT POWER
- △ F6 ONLY USED ON 240VOLT UNITS WITH FIELD INSTALLED POWER EXHAUST
- △ REFER TO UNIT DIAGRAM SECTION B3 WHEN INVERTER IS USED
- △ NOTE: FOR USE WITH COPPER CONDUCTORS MINIMUM CIRCUIT AMPACITY AND MAXIMUM OVERCURRENT PROTECTION SIZE.
- △ F10 USED ON UNITS WITH SCOR OPTION; F61 USED ON LCH UNITS WITH SCOR OPTION
- △ C610 NOT AVAILABLE ON UNITS WITH SCOR OPTION
- △ MOVE WIRE FROM 240 TO 208 TAP ON TRANSFORMER FOR 208 VOLT APPLICATIONS
- DENOTES OPTIONAL COMPONENTS
- LINE VOLTAGE FIELD INSTALLED

08/18	WIRING DIAGRAM
2018/08	537702-03
COOLING	
LCH, LGH - 210 G, J, Y	
SECTION B	
Supersedes:	New Form No.
537702-02	537702-03
REV. 0	

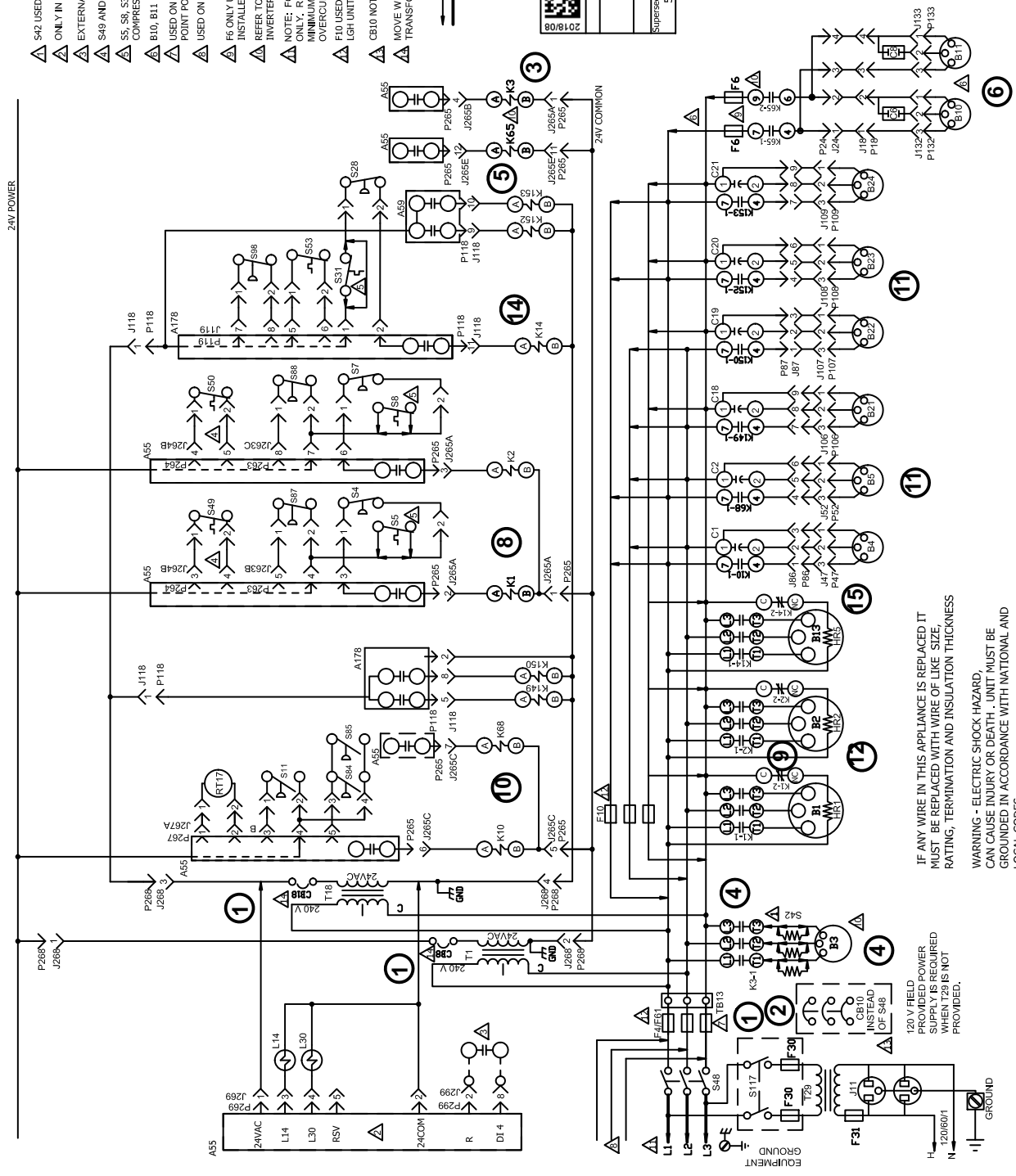

IF ANY WIRE IN THIS APPLIANCE IS REPLACED IT MUST BE REPLACED WITH WIRE OF LIKE SIZE, RATING, TERMINATION AND INSULATION THICKNESS.

WARNING - ELECTRIC SHOCK HAZARD. CAN CAUSE INJURY OR DEATH - UNIT MUST BE GROUNDED IN ACCORDANCE WITH NATIONAL AND LOCAL CODES.

DISCONNECT ALL POWER BEFORE SERVICING.

120 V FIELD PROVIDED POWER SUPPLY IS REQUIRED WHEN T29 IS NOT PROVIDED.

LGH210 KEY DESCRIPTION

KEY	COMPONENT
A55	PANEL, MAIN
A178	PANEL, COMP 3 & 4 AND 2ND STAGE HEAT - C3
B1	COMPRESSOR 1
B2	COMPRESSOR 2
B3	MOTOR, BLOWER
B4	MOTOR, OUTDOOR FAN 1
B5	MOTOR, OUTDOOR FAN 2
B10	MOTOR, EXHAUST FAN 1
B11	MOTOR, EXHAUST FAN 2
B13	COMPRESSOR 3
B21	MOTOR, OUTDOOR FAN 3
B22	MOTOR, OUTDOOR FAN 4
B23	MOTOR, OUTDOOR FAN 5
B24	MOTOR, OUTDOOR FAN 6
C1	CAPACITOR, OUTDOOR FAN 1
C2	CAPACITOR, OUTDOOR FAN 2
C6	CAPACITOR, EXHAUST FAN 1
C8	CAPACITOR, EXHAUST FAN 2
C18	CAPACITOR, OUTDOOR FAN 3
C19	CAPACITOR, OUTDOOR FAN 4
C20	CAPACITOR, OUTDOOR FAN 5
C21	CAPACITOR, OUTDOOR FAN 6
CB8	CIRCUIT, BREAKER T1
CB10	CIRCUIT BREAKER, MAIN DISCONNECT UNIT
CB18	CIRCUIT, BREAKER T18
F4	FUSE, MAIN UNIT
F6	FUSE, EXHAUST FAN
F10	FUSE, OUTDOOR FAN MOTOR
F30	FUSE, TRANSFORMER T29 PRIMARY
F31	FUSE, TRANSFORMER T29 SECONDARY
F61	FUSE, UNIT SCOR OPTION
HR1	HEATER COMPRESSOR 1
HR2	HEATER COMPRESSOR 2
HR5	HEATER COMPRESSOR 3
J11	JACK, GFI, RECEPTACLE
K1,-1	CONTACTOR, COMPRESSOR 1
K2,-1	CONTACTOR, COMPRESSOR 2
K3,-1	CONTACTOR, BLOWER
K10,-1	RELAY, OUTDOOR FAN 1
K14,-1	CONTACTOR, COMPRESSOR 3
K65-1,2	RELAY, EXHAUST FAN
K68,-1	RELAY, OUTDOOR FAN 2
K149,-1	RELAY, OUTDOOR FAN 3
K150,-1	RELAY, OUTDOOR FAN 4
K152,-1	RELAY, OUTDOOR FAN 5
K153,-1	RELAY, OUTDOOR FAN 6
L14	VALVE, SOLENOID REHEAT COIL 1
L30	VALVE, SOLENOID REHEAT COIL 2
RT17	SENSOR, OUTDOOR AIR
S4	SWITCH, LIMIT HI PRESS COMPRESS 1
S5	SWITCH, LIMIT HI TEMP COMPRESSOR 1
S7	SWITCH, LIMIT HI PRESS COMPRESS 2
S8	SWITCH, LIMIT HI TEMP COMPRESSOR 2
S11	SWITCH, LOW PRESS, LOW AMBIENT KIT COMP 1
S28	SWITCH, LIMIT HI PRESS COMPRESS 3
S31	SWITCH, LIMIT HI TEMP COMPRESSOR 3
S42	SWITCH, OVERLOAD RELAY BLOWER MOTOR
S48	SWITCH, DISCONNECT
S49	SWITCH, FREEZE STAT COMPRESS 1
S50	SWITCH, FREEZE STAT COMPRESS 2

S53	SWITCH, FREEZE STAT COMPRESS 3
S84	SWITCH, LOW PRESS, LOW AMBIENT KIT COMP 2
S85	SWITCH, LOW PRESS, LOW AMBIENT KIT COMP 3
S87	SWITCH, LOW PRESS, COMP 1
S88	SWITCH, LOW PRESS, COMP 2
S98	SWITCH, LOW PRESS, COMP 3
S117	SWITCH, GFI
T1	TRANSFORMER, CONTROL
T18	TRANSFORMER, CONTACTOR
T29	TRANSFORMER, GFI
TB13	TERMINAL STRIP, POWER DISTRIBUTION

J/P	JACK/PLUG DESCRIPTION
18	EXHAUST FAN COMP
24	EXHAUST FAN
47	OUTDOOR FAN 1
52	OUTDOOR FAN 2
86	OUTDOOR FAN INTERFACE
87	OUTDOOR FAN INTERFACE 2
106	OUTDOOR FAN 3
107	OUTDOOR FAN 4
108	OUTDOOR FAN 5
109	OUTDOOR FAN 6
118	COMPRESSOR 3 AND 4, CONTROL
119	COMPRESSOR 3 AND 4, INPUT
132	EXHAUST FAN MOTOR 1
133	EXHAUST FAN MOTOR 2
263	HIGH AND LOW PRESSURE SWITCHES
264	BLOWER DECK
265	CONTACTORS AND RELAYS
267	OUTDOOR FAN AREA
268	TRANSFORMER POWER
269	HUMIDITROL POWER/CONTROL
299	HUMIDITROL INTERFACE/SAFETY

LGH240/300 UNIT DIAGRAM

08/18	WIRING DIAGRAM
537703-03	
COOLING	
LCH, LGH - 240, 300 - G, J, M, Y	
SECTION B	
New Form No.	537703-02
Supersedes	537703-03

- △ S42 USED ON "M" VOLTAGE UNITS AND UNITS WITH 10HP MOTORS
- △ ONLY ON UNITS WITH HUMIDITROL OPTION
- △ EXTERNAL HUMIDITROL CONTACTS
- △ F6 AND F10 FUSES ARE USED ON "Y" VOLTAGE UNITS AND SCCR OPTION UNITS
- △ S49 AND S50 ARE PART OF 5VDC CIRCUIT
- △ S5, S8, S31, S180 USED ON UNITS WITH INTERLINK COMPRESSORS ONLY
- △ B10, B11 NOT USED ON UNITS WITH ERV
- △ USED ON LCH AND UNITS WITH ERV SINGLE POINT POWER. SEE ERV DIAGRAM
- △ USED ON UNITS WITH ERV SINGLE POINT POWER
- △ REFER TO UNIT DIAGRAM SECTION B3 WHEN INVERTER IS USED
- △ NOTE: FOR USE WITH COPPER CONDUCTORS ONLY. REFER TO UNIT RATING PLATE FOR MINIMUM CIRCUIT AMPACITY AND MAXIMUM OVERCURRENT PROTECTION SIZE.
- △ F61 USED ON ALL UNITS WITH LGH UNITS SCCR OPTION
- △ CB10 NOT AVAILABLE ON UNITS WITH SCCR OPTION
- △ MOVE WIRE FROM 240 TO 208 TAP ON TRANSFORMER FOR 208 VOLT APPLICATIONS

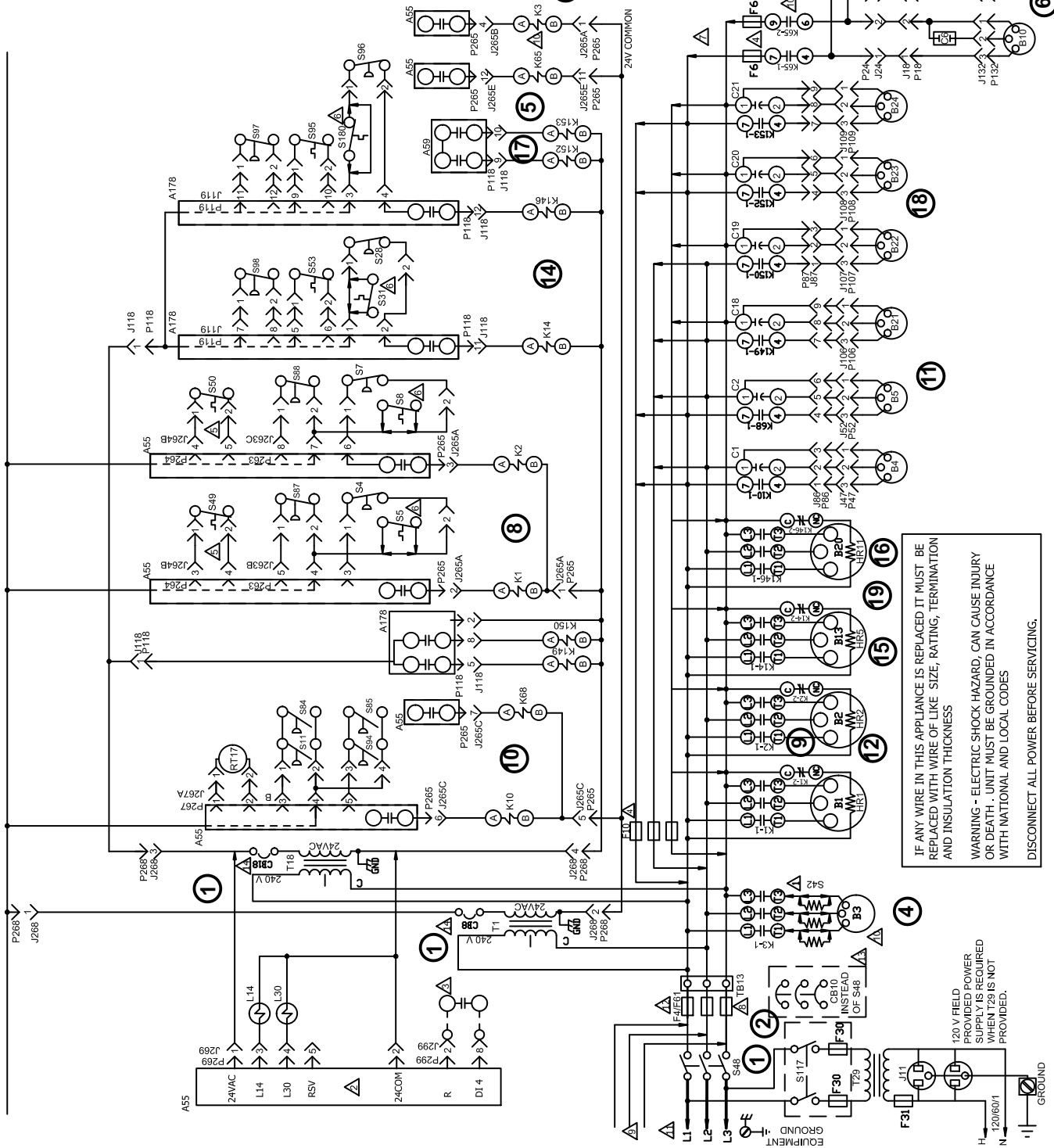

— DENOTES OPTIONAL COMPONENTS
 — LINE VOLTAGE FIELD INSTALLED

IF ANY WIRE IN THIS APPLIANCE IS REPLACED IT MUST BE REPLACED WITH WIRE OF LIKE SIZE, RATING, TERMINATION AND INSULATION THICKNESS

WARNING - ELECTRIC SHOCK HAZARD, CAN CAUSE INJURY OR DEATH. UNIT MUST BE GROUNDED IN ACCORDANCE WITH NATIONAL AND LOCAL CODES

DISCONNECT ALL POWER BEFORE SERVICING.

120V FIELD SUPPLY IS REQUIRED WHEN T29 IS NOT PROVIDED.

LGH240/300 KEY DESCRIPTION

KEY	COMPONENT
A55	MAIN CONTROL BOARD
A178	PANEL, COMP 3 & 4 AND STAGE HEAT - C3
B1	COMPRESSOR 1
B2	COMPRESSOR 2
B3	MOTOR, BLOWER
B4	MOTOR, OUTDOOR FAN 1
B5	MOTOR, OUTDOOR FAN 2
B10	MOTOR, EXHAUST FAN 1
B11	MOTOR, EXHAUST FAN 2
B13	COMPRESSOR 3
B20	COMPRESSOR 4
B21	MOTOR, OUTDOOR FAN 3
B22	MOTOR, OUTDOOR FAN 4
B23	MOTOR, OUTDOOR FAN 5
B24	MOTOR, OUTDOOR FAN 6
C1	CAPACITOR, OUTDOOR FAN 1
C2	CAPACITOR, OUTDOOR FAN 2
C6	CAPACITOR, EXHAUST FAN 1
C8	CAPACITOR, EXHAUST FAN 2
C18	CAPACITOR, OUTDOOR FAN 3
C19	CAPACITOR, OUTDOOR FAN 4
C20	CAPACITOR, OUTDOOR FAN 5
C21	CAPACITOR, OUTDOOR FAN 6
CB8	CIRCUIT, BREAKER T1
CB10	CIRCUIT BREAKER, MAIN DISCONNECT UNIT
CB18	CIRCUIT, BREAKER T18
F4	FUSE, MAIN UNIT
F6	FUSE, EXHAUST FAN
F10	FUSE, OUTDOOR FAN MOTOR
F30	FUSE, TRANSFORMER T29 PRIMARY
F31	FUSE, TRANSFORMER T29 SECONDARY
F61	FUSE, UNIT SCCR OPTION
HR1	HEATER COMPRESSOR 1
HR2	HEATER COMPRESSOR 2
HR5	HEATER COMPRESSOR 3
HR11	HEATER COMPRESSOR 4
J11	JACK, GFI, RECEPTACLE
K1, -1	CONTACTOR, COMPRESSOR 1
K2, -1	CONTACTOR, COMPRESSOR 2
K3, -1	CONTACTOR, BLOWER
K10,-1,2	RELAY, OUTDOOR FAN 1
K14, -1	CONTACTOR, COMPRESSOR 3
K65-1,2	RELAY, EXHAUST FAN
K68,-1	RELAY, OUTDOOR FAN 2
K146,-1	CONTACTOR, COMPRESSOR 4
K149,-1	RELAY, OUTDOOR FAN 3
K150,-1	RELAY, OUTDOOR FAN 4
K152,-1	RELAY, OUTDOOR FAN 5
K153,-1,2	RELAY, OUTDOOR FAN 6
L14	VALVE, SOLENOID REHEAT COIL 1
L30	VALVE, SOLENOID REHEAT COIL 2
RT17	SENSOR, OUTDOOR AIR
S4	SWITCH, LIMIT HI PRESS COMPRESS 1
S5	SWITCH, LIMIT HI TEMP COMPRESSOR 1
S7	SWITCH, LIMIT HI PRESS COMPRESS 2
S8	SWITCH, LIMIT HI TEMP COMPRESSOR 2
S11	SWITCH, LOW PRESS, LOW AMBIENT COMP 1
S28	SWITCH, LIMIT HI PRESS COMPRESS 3
S31	SWITCH, LIMIT HI TEMP COMPRESSOR 3
S42	SWITCH, OVERLOAD RELAY BLOWER MOTOR
S48	SWITCH, DISCONNECT

S49	SWITCH, FREEZE STAT COMPRESS 1
S50	SWITCH, FREEZE STAT COMPRESS 2
S53	SWITCH, FREEZE STAT COMPRESS 3
S84	SWITCH, LOW PRESS, LOW AMBIENT KIT COMP 2
S85	SWITCH, LOW PRESS, LOW AMBIENT KIT COMP 3
S87	SWITCH, LOW PRESS, COMP 1
S88	SWITCH, LOW PRESS, COMP 2
S94	SWITCH, LOW PRESS, LOW AMBIENT KIT COMP 4
S95	SWITCH, FREEZE STAT COMPRESS 4
S96	SWITCH, LIMIT HI PRESS COMPRESS 4
S97	SWITCH, LOW PRESS, COMP 4
S98	SWITCH, LOW PRESS, COMP 3
S117	SWITCH, GFI
S180	SWITCH, LIMIT HI TEMP COMPRESSOR 4
T1	TRANSFORMER, CONTROL
T18	TRANSFORMER, CONTACTOR
T29	TRANSFORMER, GFI
TB13	TERMINAL STRIP, POWER DISTRIBUTION

J/P	JACK/PLUG DESCRIPTION
18	POWER EXHAUST HARNESS
24	RELAY TO EXHAUST FANS
47	POWER TO OUTDOOR FAN 1
52	POWER TO OUTDOOR FAN 2
86	OUTDOOR FAN INTERFACE
87	OUTDOOR FAN INTERFACE 2
106	POWER TO OUTDOOR FAN 3
107	POWER TO OUTDOOR FAN 4
108	POWER TO OUTDOOR FAN 5
109	POWER TO OUTDOOR FAN 6
118	COMPRESSOR 3 AND 4, CONTROL
119	COMPRESSOR 3 AND 4, INPUT
132	POWER TO EXHAUST FAN MOTOR 1
133	POWER TO EXHAUST FAN MOTOR 2
263	HIGH AND LOW PRESSURE SWITCHES
264	BLOWER DECK
265	CONTACTORS AND RELAYS
267	OUTDOOR FAN AREA
268	24V POWER FROM TRANSFORMERS TO A55
269	HUMIDITROL
299	HUMIDITROL INTERFACE TO A55

Sequence of Operation LGH156/300

POWER:

1. Line voltage from TB2, unit disconnect S48, or other factory or field installed optional power disconnects, such as CB10, energizes transformer T1 and T18. Transformer T1 provides 24VAC power to the A55 Unit Controller and T18 provides 24VAC power to A59 Compressor 3 and 4 Controller. The two controllers provide 24VAC power to the unit cooling, heating and blower controls and thermostat.
2. Terminal block TB13 is also energized when the unit disconnect closes. TB13 supplies line voltage to compressor crankcase heaters, compressors, blower motors and fan motors.

BLOWER OPERATION (OCP INPUT MUST BE ON):

3. The A55 Unit Controller receives a demand from thermostat terminal G. A55 energizes blower contactor K3 with 24VAC.
4. N.O. K3-1 closes, energizing blower B3.

ECONOMIZER OPERATION:

5. The A55 Unit Controller receives a demand and energizes exhaust fan relay K65 with 24VAC at 50% (travel) outside air damper open (adjustable).
6. N.O. K65-1 and K65-2 both close, energizing exhaust fan motors B10 and B11.

1ST STAGE COOLING (BOTH COMPRESSORS B1 AND B2 ARE ENERGIZED):

7. First stage cooling demand energizes Y1 and G in the thermostat. G energizes blower, if blower is not already running (see step 3).
8. 24VAC is routed to the A55 Unit Controller. After A55 proves N.C. low pressure switch S87 and S88, N.C. freezestat S49 and S50 and N.C. high pressure switch S4 and S7, compressor contactors K1 and K2 are energized.
9. N.O. contacts K1-1 and K2-1 close energizing compressor B1 and B2.

10. A55 Unit Controller and A178 Compressor 3 and 4 Controller energize fan contactor K10 (all units), K68 (all units), K149 (180H-300S only), K150 (180/210H only), K152 (210H only), K153 (210H only) based on low ambient switch S11 and S84 inputs and predefined control logic.
11. N.O. contact K10-1 (all units), K68-1 (all units), K149-1 (180H-300S only), K150-1 (180H/210H only), K152-1 (210H only), K153-1 (210H only) close energizing fan B4 (all units), B5 (all units), B21 (all units), B22 (180H/210H only), B23 (210H only), B24 (210H only).
12. Relay contacts K10-1 (210H), K10-2 (156H, 240H, 300S) or K68-1 (180H) open de-energizing compressor 1, 2 and 3 crankcase heater HR1 (all units), HR2 (all units) and HR5 (156H-210H only).

2ND STAGE COOLING (B13 IN 156H-210H AND BOTH B13 AND B20 IN 240H AND 300S ARE ENERGIZED):

13. Second stage cooling demand energizes Y2.
 14. 24VAC is routed to A59 Compressor 3 and 4 Controller. After A59 proves N.C. low pressure switches S98 and S97, N.C. freezestats S53 and S95 and N.C. high pressure switches S28 and S96, compressor contactors K14 and K146 are energized.
- NOTE: LGH156-210 units will be equipped with S98, S53, S28 and K14 only.*
15. N.O. contacts K14-1 close energizing compressor B13.
 16. N.O. contacts K146-1 close energizing compressor B20 (LGH240/300 only).
 17. A59 Compressor 3 and 4 Controller energizes fan contactor K150, K152, K153 (240H/300S only) based on low ambient switch S85 and S94 inputs and predefined Controller logic.
 18. N.O. contacts K150-1, K152-1 and K153-1 (240H/300S only) close energizing condenser fan B22, B23 and B24 (240H/300S only).
 19. N.C. contacts K153-2 (240H/300S only) open de-energizing compressor 3 and 4 crankcase heater HR5 and HR11 (240/300S only).

LGH180U/240U/300U UNIT DIAGRAM

201905	WIRING DIAGRAM	05/19
537717-04		
COOLING -MSAV NO BYPASS		
LCH/LGH - 180, 240, 300 ULTRA - G, J, Y		
SECTION B		REV. 0
Supersedes	New Form No.	
537717-03	537717-04	

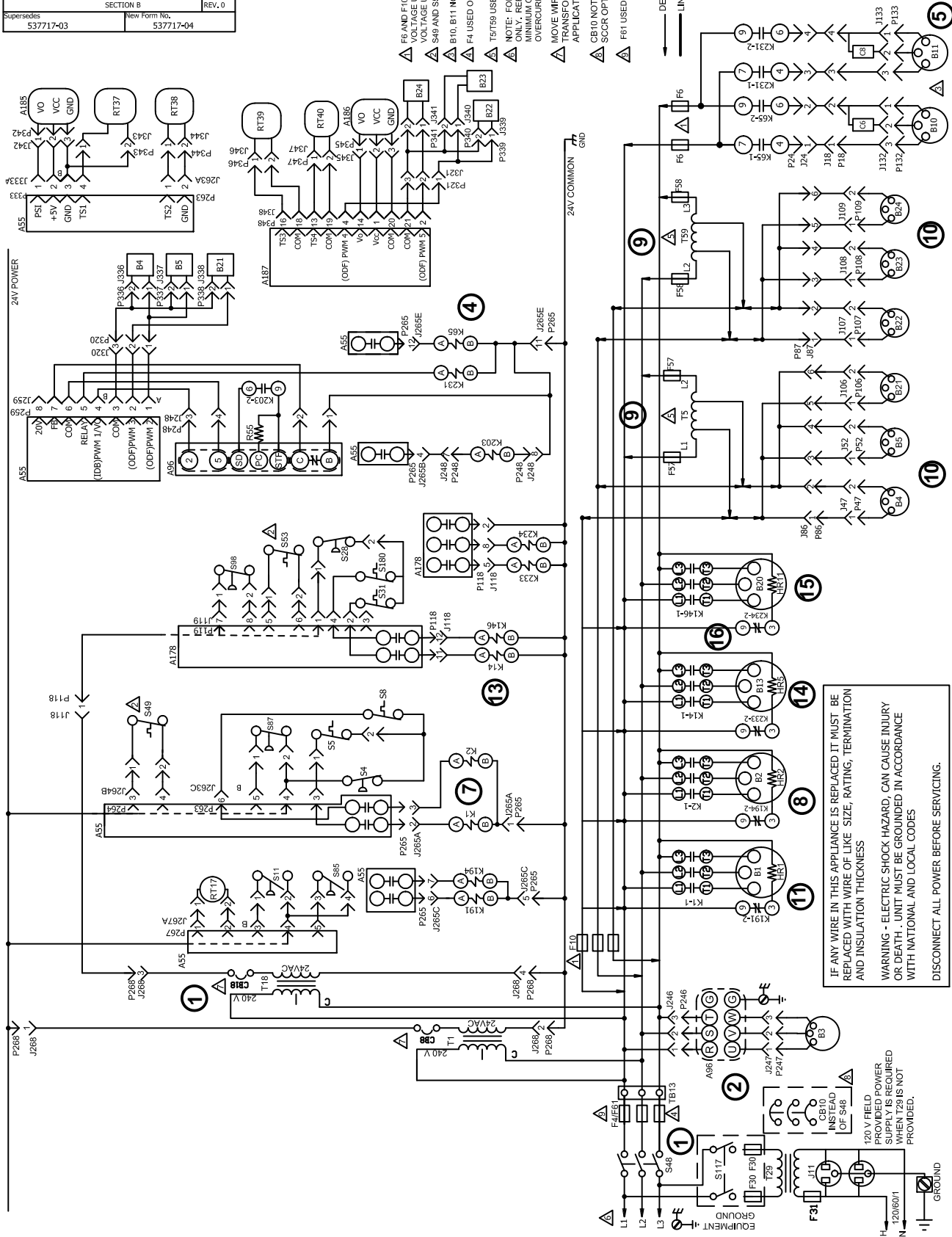

- △ F6 AND F10 FUSES ARE USED ON ALL "Y" VOLTAGE UNITS AND SCOR OPTION G & J VOLTAGE UNITS
- △ S49 AND S53 ARE PART OF 5VDC CIRCUIT
- △ B10, B11 NOT USED ON UNITS WITH ERV
- △ F4 USED ON LCH UNITS
- △ T9189 USED ON ALL G & J VOLTAGE UNITS
- NOTE: FOR USE WITH COPPER CONDUCTORS ONLY. REFER TO UNIT RATING PLATE FOR MINIMUM CIRCUIT AMPACITY AND MAXIMUM OVERCURRENT PROTECTION SIZE.
- △ MOVE WIRE FROM 240 TO 208 TAP ON TRANSFORMER FOR 208 VOLT APPLICATIONS
- △ CB10 NOT AVAILABLE ON UNITS WITH SCOR OPTION
- △ F81 USED ON LGH UNITS SCOR OPTION

— DENOTES OPTIONAL COMPONENTS
 — LINE VOLTAGE FIELD INSTALLED

IF ANY WIRE IN THIS APPLIANCE IS REPLACED IT MUST BE REPLACED WITH WIRE OF LIKE SIZE, RATING, TERMINATION AND INSULATION THICKNESS
 WARNING - ELECTRIC SHOCK HAZARD, CAN CAUSE INJURY OR DEATH - UNIT MUST BE GROUNDED IN ACCORDANCE WITH NATIONAL AND LOCAL CODES
 DISCONNECT ALL POWER BEFORE SERVICING.

120V FIELD POWER SUPPLY IS REQUIRED WHEN T29 IS NOT PROVIDED.

LGH180U, 240U, 300U KEY DESCRIPTION

J/P	JACK/PLUG DESCRIPTION
18	POWER EXHAUST HARNESS
24	RELAY TO EXHAUST FANS
47	MOTOR, OUTDOOR FAN 1
52	MOTOR, OUTDOOR FAN 2
86	OUTDOOR FANS 1
87	OUTDOOR FANS 2
106	MOTOR, OUTDOOR FAN 3
107	MOTOR, OUTDOOR FAN 4
108	MOTOR, OUTDOOR FAN 5
109	MOTOR, OUTDOOR FAN 6
118	COMPRESSOR 3 AND 4, CONTROL A178
119	COMPRESSOR 3 AND 4, INPUT
132	POWER TO EXHAUST FAN MOTOR 1
133	POWER TO EXHAUST FAN MOTOR 2
246	POWER TO VFD
247	VFD TO MTR
248	VFD CONTROL
259	BLOWER ECM MOTOR
263	HIGH AND LOW PRESSURE SWITCHES
264	BLOWER DECK AREA
265	CONTACTORS AND RELAYS
267	OUTDOOR FAN AREA
268	24V POWER FROM TRANSFORMERS TO A55
320	OD FAN CONTROL SET 1
321	OD FAN CONTROL SET 2
333	0-5V TRANSDUCER INPUT
336	OD FAN CONTROL, B4
337	OD FAN CONTROL, B5
338	OD FAN CONTROL, B21
339	OD FAN CONTROL, B22
340	OD FAN CONTROL, B23
341	OD FAN CONTROL, B24
342	COMPRESSOR PRESSURE TRANSDUCER STG 1
343	TEMPERATURE SENSOR COMPRESSOR 1
344	TEMPERATURE SENSOR COMPRESSOR 2
345	COMPRESSOR PRESSURE TRANSDUCER STG 2
346	TEMPERATURE SENSOR COMPRESSOR 3
347	TEMPERATURE SENSOR COMPRESSOR 4
348	CONTROL GENERAL PURPOSE GP3

KEY	COMPONENT
A55	MAIN CONTROL BOARD
A96	CONTROL INVERTER
A178	PANEL, COMP 3&4, C3 2nd STAGE HEAT
A185	TRANSDUCER TANDEM COMPRESSOR STG 1
A186	TRANSDUCER TANDEM COMPRESSOR STG 2
A187	CONTROL GENERAL PURPOSE GP3
B1	COMPRESSOR 1
B2	COMPRESSOR 2
B3	MOTOR, BLOWER
B4	MOTOR, OUTDOOR FAN 1
B5	MOTOR, OUTDOOR FAN 2
B10	MOTOR, EXHAUST FAN 1
B11	MOTOR, EXHAUST FAN 2
B13	COMPRESSOR 3
B20	COMPRESSOR 4
B21	MOTOR, OUTDOOR FAN 3
B22	MOTOR, OUTDOOR FAN 4
B23	MOTOR, OUTDOOR FAN 5
B24	MOTOR, OUTDOOR FAN 6
C6	CAPACITOR, EXHAUST FAN 1
C8	CAPACITOR, EXHAUST FAN 2
CB8	CIRCUIT, BREAKER T1
CB10	CIRCUIT BREAKER, MAIN DISCONNECT UNIT
CB18	CIRCUIT, BREAKER T18
F4	FUSE, MAIN UNIT
F6	FUSE, EXHAUST FAN
F10	FUSE, OUTDOOR FAN MOTOR
F30	FUSE, TRANSFORMER T29 PRIMARY
F31	FUSE, TRANSFORMER T29 SECONDARY
F57	FUSE, TRANSFORMER T5 PRIMARY
F58	FUSE, TRANSFORMER T59 PRIMARY
F61	FUSE, UNIT SCCR OPTION
HR1	HEATER COMPRESSOR 1
HR2	HEATER COMPRESSOR 2
HR5	HEATER COMPRESSOR 3
HR11	HEATER 1, COMPRESSOR 4
J11	JACK, GFI, RECEPTACLE
K1, -1	CONTACTOR, COMPRESSOR 1
K2, -1	CONTACTOR, COMPRESSOR 2
K3-1	RELAY-CONTRACTOR, BLOWER
K14, -1	CONTACTOR, COMPRESSOR 3
K65-1,2	RELAY, EXHAUST FAN
K146-1	CONTACTOR, COMPRESSOR 4
K191-2	RELAY, CRANKCASE HEATER 1
K194-2	RELAY, CRANKCASE HEATER 2
K202-1	RELAY, INVERTER
K203-2	RELAY, CONTROL INVERTER
K231-1,2	RELAY, EXHAUST FAN 2
K233-2	RELAY, CRANKCASE HEATER 3
K234-2	RELAY, CRANKCASE HEATER 4
R55	RESISTOR, VFD LOADING, A96
RT17	SENSOR, OUTDOOR AIR
RT37	SENSOR THERMISTOR 1, COMPRESSOR 1
RT38	SENSOR THERMISTOR 2, COMPRESSOR 2
RT39	SENSOR THERMISTOR 3, COMPRESSOR 3
RT40	SENSOR THERMISTOR 4, COMPRESSOR 4
S4	SWITCH, LIMIT HI PRESS COMPRESS 1
S5	SWITCH, LIMIT HI TEMP COMPRESSOR 1
S8	SWITCH, LIMIT HI TEMP COMPRESSOR 2
S11	SWITCH, LOW PRESS, LOW AMBIENT COMP 1
S28	SWITCH, LIMIT HI PRESS COMPRESS 3
S31	LIMIT, HIGH TEMP COMPRESSOR 3
S48	SWITCH, DISCONNECT
S49	SWITCH, FREEZE STAT COMPRESS 1
S53	SWITCH, FREEZE STAT COMPRESS 3
S85	SWITCH, LOW PRESS, LOW AMBIENT KIT COMP 3
S87	SWITCH, LOW PRESS, COMP 1
S98	SWITCH, LOW PRESS, COMP 3
S117	SWITCH, GFI
S180	LIMIT, HIGH TEMP COMPRESSOR 4
T1	TRANSFORMER, CONTROL
T5	TRANSFORMER, OUTDOOR FAN MOTOR
T18	TRANSFORMER, CONTACTOR
T29	TRANSFORMER, GFI
T59	TRANSFORMER, OUTDOOR FAN MOTOR
TB13	TERMINAL STRIP, POWER DISTRIBUTION

Sequence of Operation LGH180U, 240U, 300U

POWER:

1. Line voltage from TB2, unit disconnect S48, or other factory or field installed optional power disconnects, such as CB10, energizes transformer T1 and T18. Transformer T1 provides 24VAC power to the A55 Unit Controller and T18 provides 24VAC power to A59 Compressor 3 and 4 Controller. The two controllers provide 24VAC power to the unit cooling, heating and blower controls and thermostat.
2. Terminal block TB13 is also energized when the unit disconnect closes. TB13 supplies line voltage to compressor crankcase heaters, compressors, blower motors and fan motors.
7. 24VAC is routed to the A55 Unit Controller. After A55 proves N.C. low pressure switch S87, N.C. freezestat S49, and N.C. high pressure switch S4, high temperature limits S5 and S8, compressor contactors K1 and K2 are energized.
8. N.O. contacts K1-1 and K2-1 close energizing compressor B1 and B2.
9. A55 Unit Controller and A178 Compressor 3 and 4 Controller energize fan transformers T5 and T59 based on low ambient switch S11 and S85 inputs and predefined control logic.
10. Transformer T5 energizes outdoor fans B4, B5 and B21. Transformer T59 energizes outdoor fan B22, B23 and B24.

BLOWER OPERATION (OCP INPUT MUST BE ON):

3. See Staged No Bypass and Staged With Bypass next 2 pages.

ECONOMIZER OPERATION:

4. The A55 Unit Controller receives a demand and energizes exhaust fan relay K65 and K231 with 24VAC at 50% (travel) outside air damper open (adjustable).
5. N.O. K65-1, K65-2, K231-01 and K231-02 close, energizing exhaust fan motors B10 and B11.

1ST STAGE COOLING

6. First stage cooling demand energizes Y1 and G in the thermostat. G energizes blower, if blower is not already running (see step 3).

2ND STAGE COOLING

12. Second stage cooling demand energizes Y2.
13. 24VAC is routed to A178 Compressor 3 and 4 Controller. After A178 proves N.C. low pressure switch S98, N.C. freezestat S53, and N.C. high pressure switch S28, high temperature limits S31 and S180, compressor contactors K14 and K146 are energized
14. N.O. contacts K14-1 close energizing compressor B13.
15. N.O. contacts K146-1 close energizing compressor B20.
16. N.C. contacts K233-2 and K234-01 open de-energizing compressor 3 and 4 crankcase heater HR5 and HR11.

Staged-Blower UNITS - NO BYPASS

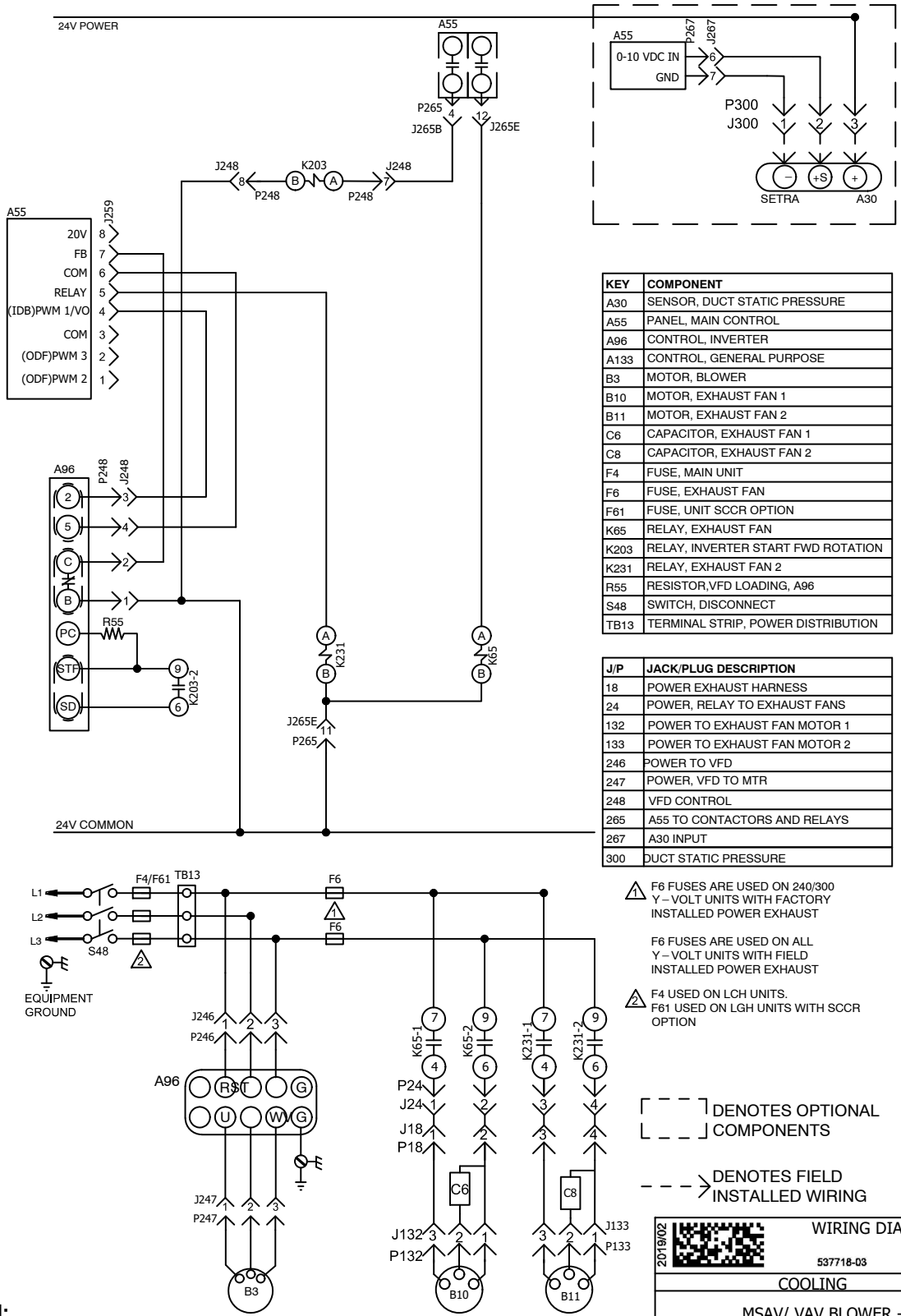

KEY	COMPONENT
A30	SENSOR, DUCT STATIC PRESSURE
A55	PANEL, MAIN CONTROL
A96	CONTROL, INVERTER
A133	CONTROL, GENERAL PURPOSE
B3	MOTOR, BLOWER
B10	MOTOR, EXHAUST FAN 1
B11	MOTOR, EXHAUST FAN 2
C6	CAPACITOR, EXHAUST FAN 1
C8	CAPACITOR, EXHAUST FAN 2
F4	FUSE, MAIN UNIT
F6	FUSE, EXHAUST FAN
F61	FUSE, UNIT SCCR OPTION
K65	RELAY, EXHAUST FAN
K203	RELAY, INVERTER START FWD ROTATION
K231	RELAY, EXHAUST FAN 2
R55	RESISTOR, VFD LOADING, A96
S48	SWITCH, DISCONNECT
TB13	TERMINAL STRIP, POWER DISTRIBUTION

J/P	JACK/PLUG DESCRIPTION
18	POWER EXHAUST HARNESS
24	POWER, RELAY TO EXHAUST FANS
132	POWER TO EXHAUST FAN MOTOR 1
133	POWER TO EXHAUST FAN MOTOR 2
246	POWER TO VFD
247	POWER, VFD TO MTR
248	VFD CONTROL
265	A55 TO CONTACTORS AND RELAYS
267	A30 INPUT
300	DUCT STATIC PRESSURE

⚠ F6 FUSES ARE USED ON 240/300 Y-VOLT UNITS WITH FACTORY INSTALLED POWER EXHAUST

F6 FUSES ARE USED ON ALL Y-VOLT UNITS WITH FIELD INSTALLED POWER EXHAUST

⚠ F4 USED ON LCH UNITS.
F61 USED ON LGH UNITS WITH SCCR OPTION

--- DENOTES OPTIONAL COMPONENTS
- - - DENOTES FIELD INSTALLED WIRING

OPERATION:

1. A55 energizes the K203 relay coil.
2. K203-2 N.O. contacts close to start A96 forward rotation signal STF.
3. A133 controls the second stage power exhaust relay K231 coil through pin #5. K231-1 and -2 N.O. contacts will close to start the second power exhaust fan when A133 energizes the K231 coil.
4. Blower B3 speed is controlled by a 0-10VDC signal from A133 AO1 to A96 terminal 2.
5. A96 status is monitored by A133 through N.C. contacts B-C on A96.

2019/02		WIRING DIAGRAM	02/19
		537718-03	
COOLING			
MSAV/ VAV BLOWER - NO BYPASS			
SECTION B3		REV. 1	
Supersedes 537718-02	New Form No. 537718-03		

Staged-Blower UNITS - WITH BYPASS

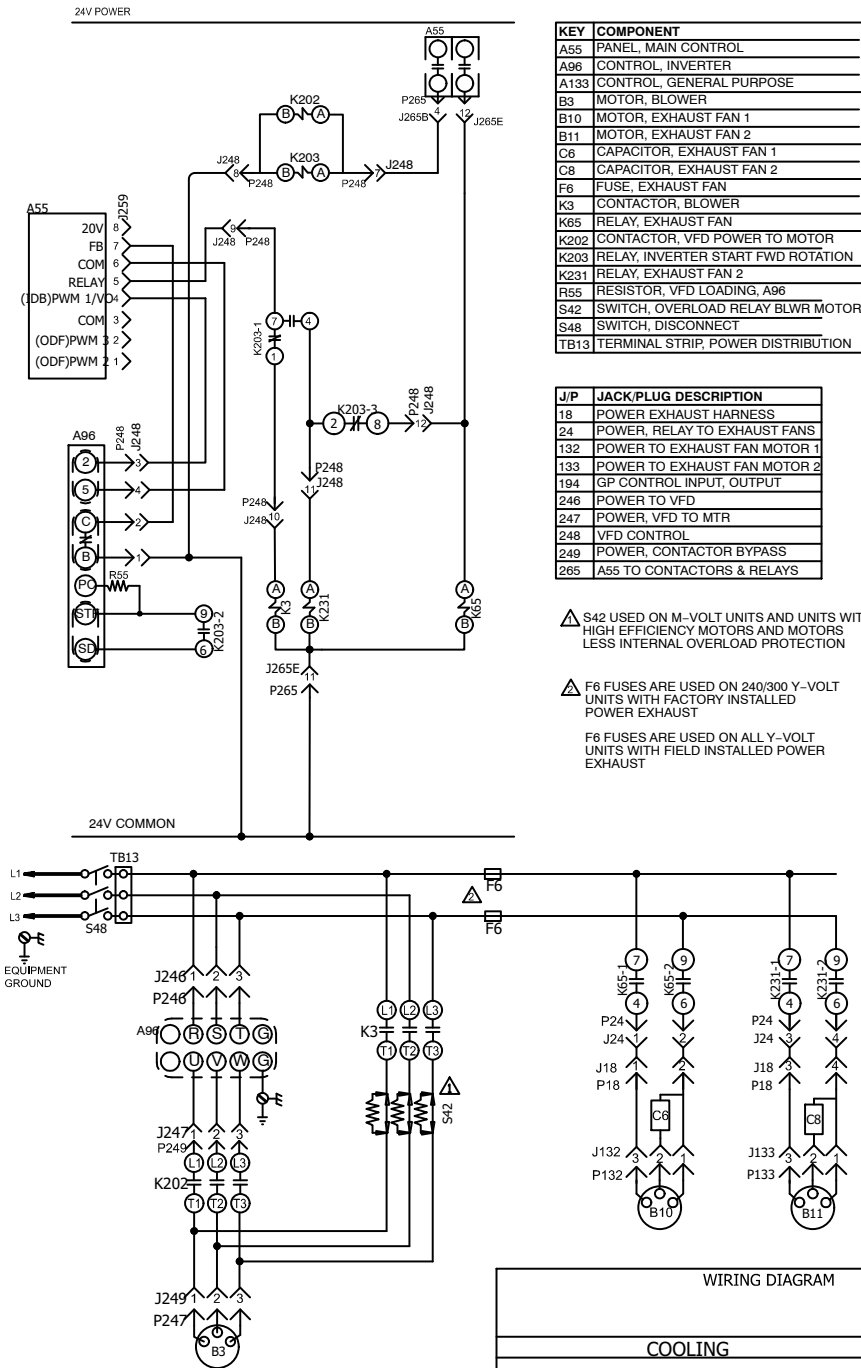

KEY	COMPONENT
A55	PANEL, MAIN CONTROL
A96	CONTROL, INVERTER
A133	CONTROL, GENERAL PURPOSE
B3	MOTOR, BLOWER
B10	MOTOR, EXHAUST FAN 1
B11	MOTOR, EXHAUST FAN 2
C6	CAPACITOR, EXHAUST FAN 1
C8	CAPACITOR, EXHAUST FAN 2
F6	FUSE, EXHAUST FAN
K3	CONTACTOR, BLOWER
K65	RELAY, EXHAUST FAN
K202	CONTACTOR, VFD POWER TO MOTOR
K203	RELAY, INVERTER START FWD ROTATION
K231	RELAY, EXHAUST FAN 2
R55	RESISTOR, VFD LOADING, A96
S42	SWITCH, OVERLOAD RELAY BLWR MOTOR
S48	SWITCH, DISCONNECT
TB13	TERMINAL STRIP, POWER DISTRIBUTION

J/P	JACK/PLUG DESCRIPTION
18	POWER EXHAUST HARNESS
24	POWER, RELAY TO EXHAUST FANS
132	POWER TO EXHAUST FAN MOTOR 1
133	POWER TO EXHAUST FAN MOTOR 2
194	GP CONTROL INPUT, OUTPUT
246	POWER TO VFD
247	POWER, VFD TO MTR
248	VFD CONTROL
249	POWER, CONTACTOR BYPASS
265	A55 TO CONTACTORS & RELAYS

⚠ S42 USED ON M-VOLT UNITS AND UNITS WITH HIGH EFFICIENCY MOTORS AND MOTORS LESS INTERNAL OVERLOAD PROTECTION

⚠ F6 FUSES ARE USED ON 240/300 Y-VOLT UNITS WITH FACTORY INSTALLED POWER EXHAUST

F8 FUSES ARE USED ON ALL Y-VOLT UNITS WITH FIELD INSTALLED POWER EXHAUST

WIRING DIAGRAM		03/17
COOLING		
MSAV BLOWER - WITH BYPASS		
SECTION B3		REV. 0
Supersedes 537391-01	New Form No. 537719-02	

1. A55 energizes K202 and K203 relay coils.
2. K203-1 N.O. contacts close and K203-3 N.C. contacts open to allow A133 to control the second stage power exhaust relay K231 coil through pin #5. K231-1 and -2 N.O. contacts will close to start the second power exhaust fan B11 when A133 energizes K231 coil.
3. K203-1 N.C. contacts open to de-energize K3 relay coil. K3 contacts open to interrupt power to B3 blower motor through K3 N.O. relay contacts.
4. K202 contacts close to allow power to B3 blower motor from A96.
5. K203-2 N.O. contacts close to start A96 forward rotation signal STF.
6. Blower B3 speed is controlled by a 0-10VDC signal from A133 AO1 to A96 terminal 2.
7. A96 status is monitored by A133 through N.C. contacts B-C on A96.

GAS HEAT DIAGRAM

NOTE - On single stage heat, terminal H1 on gas valve GV1 and GV3 is not connected to terminal H2 on A55 Unit Controller.

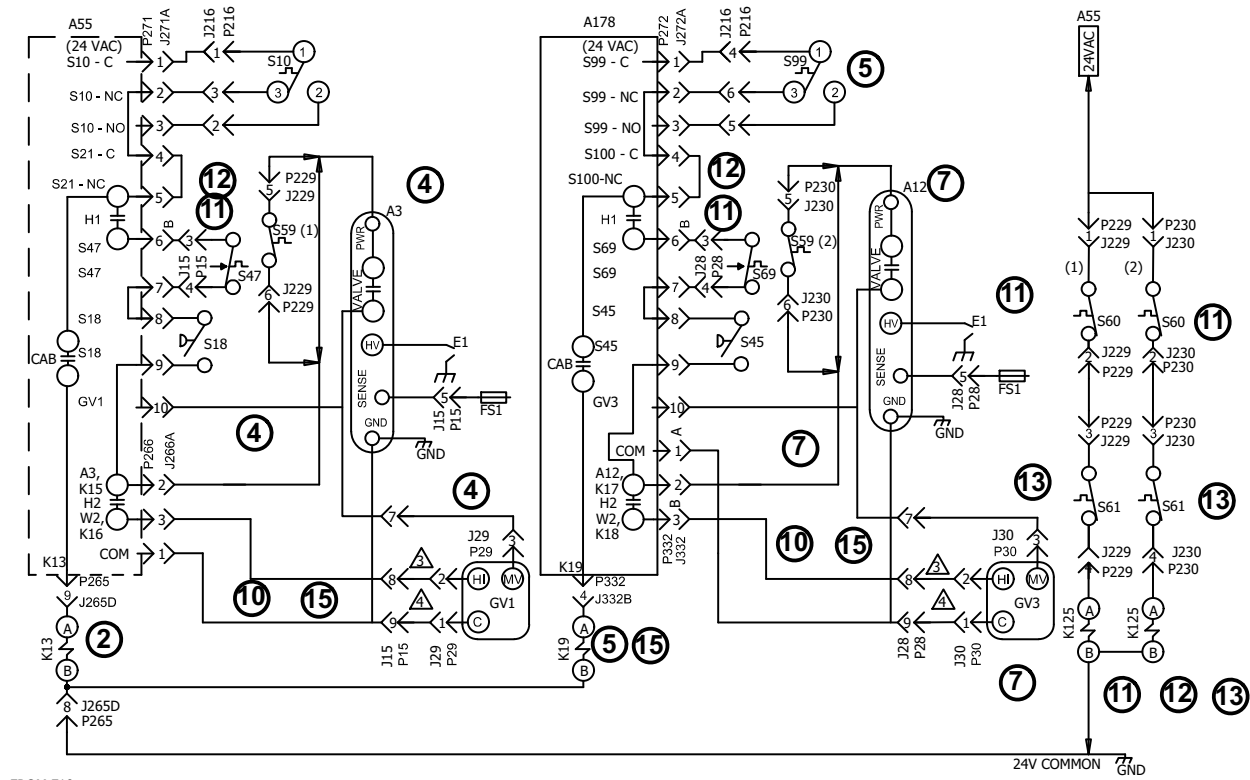

FROM F10

KEY	DESCRIPTION
A3	CONTROL, BURNER 1
A12	CONTROL, BURNER 2
A55	PANEL, MAIN CONTROL LENNOX
A178	PANEL, COMP 3 & 4, 2nd STAGE HEAT - C
B6	MOTOR COMBUSTION AIR BLOWER 1
B15	MOTOR COMBUSTION AIR BLOWER 2
C3	CAPACITOR, COMB AIR BLOWER 1
C11	CAPACITOR, COMB AIR BLOWER 2
E1	SPARK
F10	FUSE, OUTDOOR FAN MOTOR
FS1	SENSOR, FLAME
GV1	VALVE, GAS 1
GV3	VALVE, GAS 2
HR6	HEATER, -50C LOW AMBIENT KIT
K13,-1	RELAY, COMBUSTION AIR BLOWER 1
K19,-1	RELAY, COMBUSTION AIR BLOWER 2
K125,-1	RELAY, HEAT SHUT OFF
S10	SWITCH, LIMIT PRIMARY GAS
S18	SWITCH, COMB AIR BLOWER 1 PROOF
S45	SWITCH, COMB AIR BLOWER 2 PROOF
S47	SWITCH, FLAME ROLLOUT BURNER
S59	TSTAT, OPEN -20F, CLOSE 10F
S60	TSTAT, OPEN 20F, CLOSE -10F
S61	TSTAT, OPEN 50F, CLOSE 20F
S69	SWITCH, FLAME ROLLOUT 2
S99	SWITCH, LIMIT PRIMARY BURNER 2
T3	TRANSFORMER, COMB AIR BLOWER 1
T13	TRANSFORMER, COMB AIR BLOWER 2

J/P	DESCRIPTION
15	BURNER 1
19	COMBUSTION AIR BLOWER 1
21	COMBUSTION AIR BLOWER 2
28	BURNER 2
29	GAS 1 HONEY WELL VALVE
30	GAS 2 HONEY WELL VALVE
216	PRIMARY LIMIT 1
228	VESTIBULE HEATER
229	VESTIBULE HEATER CONTROL 1
230	VESTIBULE HEATER CONTROL 2
265	CONTACTOR RELAY
266	HEATING CONTROL STG 1
271	HEATING SENSORS STG 1
272	HEATING SENSORS STG 2
332	HEATING CONTROL STG 2

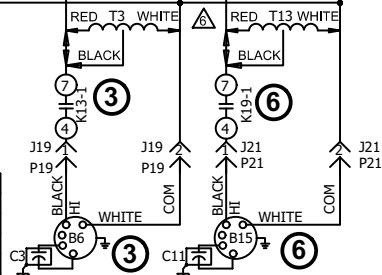

- ▲ CSA (-50C) LOW AMBIENT KIT (OPTIONAL)
- ▲ T3 AND T13 USED ON 575 V UNITS ONLY
- ▲ P15-8 TO GV1-2, P28-8 TO GV3-2, ARE OMITTED FOR LOW FIRE UNITS
- ▲ J/P 29 AND J/P 30 ONLY USED ON LGH 260, 360 AND 480 UNITS WITH HONEYWELL GAS VALVES
- ▲ F10 USED ON 240H/300S Y VOLTS, ULTRA Y VOLT UNIT AND ALL NON ULTRA UNITS WITH SCCR OPTIONS
- ▲ T3 AND T13 NOT CONNECT TO F10 ON 575V SCCR UNITS

← DENOTES OPTIONAL COMPONENTS

2018/07		WIRING DIAGRAM 537695-04	07/18
COOLING -MSAV NO BYPASS GAS HEAT FOR LGH/SGC 169,260,360 AND 480			
SECTION B			REV 0
Supersedes 537695-03		New Form No. 537695-04	

SEQUENCE OF OPERATION GAS HEAT FOR LGH156/300 UNITS

FIRST STAGE HEAT:

1. Heating demand initiates at W1 in thermostat.
2. 24VAC is routed to the A55 Unit Controller. After A55 proves N.C. primary limit S10, the combustion air blower relay K13 is energized.
3. N.O. K13-1 contacts close allowing line voltage (or transformer T3 in 575V only) to energize combustion air blower B6.
4. After the combustion air blower B6 has reached full speed, the combustion air proving switch (S18) contacts close. The A55 routes 24VAC through N.C. burner 1 flame rollout switch S47 and the closed contacts of the combustion air proving switch (S18) to energize the ignition module A3. After a 30 second delay A3 energizes the gas valve GV1 on low fire.
5. As steps 2, 3 and 4 occur, A55 proves N.C. primary gas heat limit S99 and the combustion air blower relay K19 is energized.
6. N.O. K19-1 contacts close allowing line voltage (or transformer T13 in 575V only) to energize combustion air blower B15.
7. After the combustion air blower B15 has reached full speed, the combustion air proving switch (S45) contacts close. The A55 routes 24VAC through N.C. burner 2 flame rollout switch S69 and the closed contacts of the combustion air proving switch (S45) to energize the ignition module A12. After a 30 second delay A12 energizes gas valve GV3 on low fire.

SECOND STAGE HEAT:

8. With first stage heat operating, an additional heating demand initiates W2 in the thermostat.
9. A second stage heating demand is received by A55.

10. A55 will energize the corresponding gas valves GV1 and GV3 on high fire.

OPTIONAL LOW AMBIENT KIT (C.G.A. -50° C LOW AMBIENT KIT):

11. When heat section temperature drops below -20°F, S59 opens and de-energized A3 and A12 ignition controls. At the same temperature, S60 closes and energizes K125. K125-1 contacts close energizing HR6 Cold Weather Kit electric heat.
12. When heat section temperature rises to 10°F, S59 closes allowing power to A3 and A12 ignition controls. At the same temperature, S60 opens and de-energizes K125. K125-1 contacts open de-energizing HR6 Cold Weather Kit electric heat.
13. If heat section temperature rises above 50°F, S61 will open and de-energize K125. K125-1 contacts will open and de-energize HR6 Cold Weather Kit electric heat. If heat section temperature drops to 20°F, S61 will close and allow power to K125.

END OF SECOND STAGE HEAT:

14. Heating demand is satisfied. Terminal W2 is de-energized.
15. High fire on GV1 and GV3 are de-energized by the A55.

END OF FIRST STAGE HEAT:

16. Heating demand is satisfied. Terminal W1 is de-energized.
17. Ignition module A3 is de-energized by A55 in turn de-energizing GV1. Combustion blower relay K13 is also de-energized. At the same instant, ignition module A12 is de-energized by A55 in turn de-energizing GV3. K19 combustion air blower relay is also de-energized.

ELECTRONIC OR ELECTROMECHANICAL THERMOSTAT

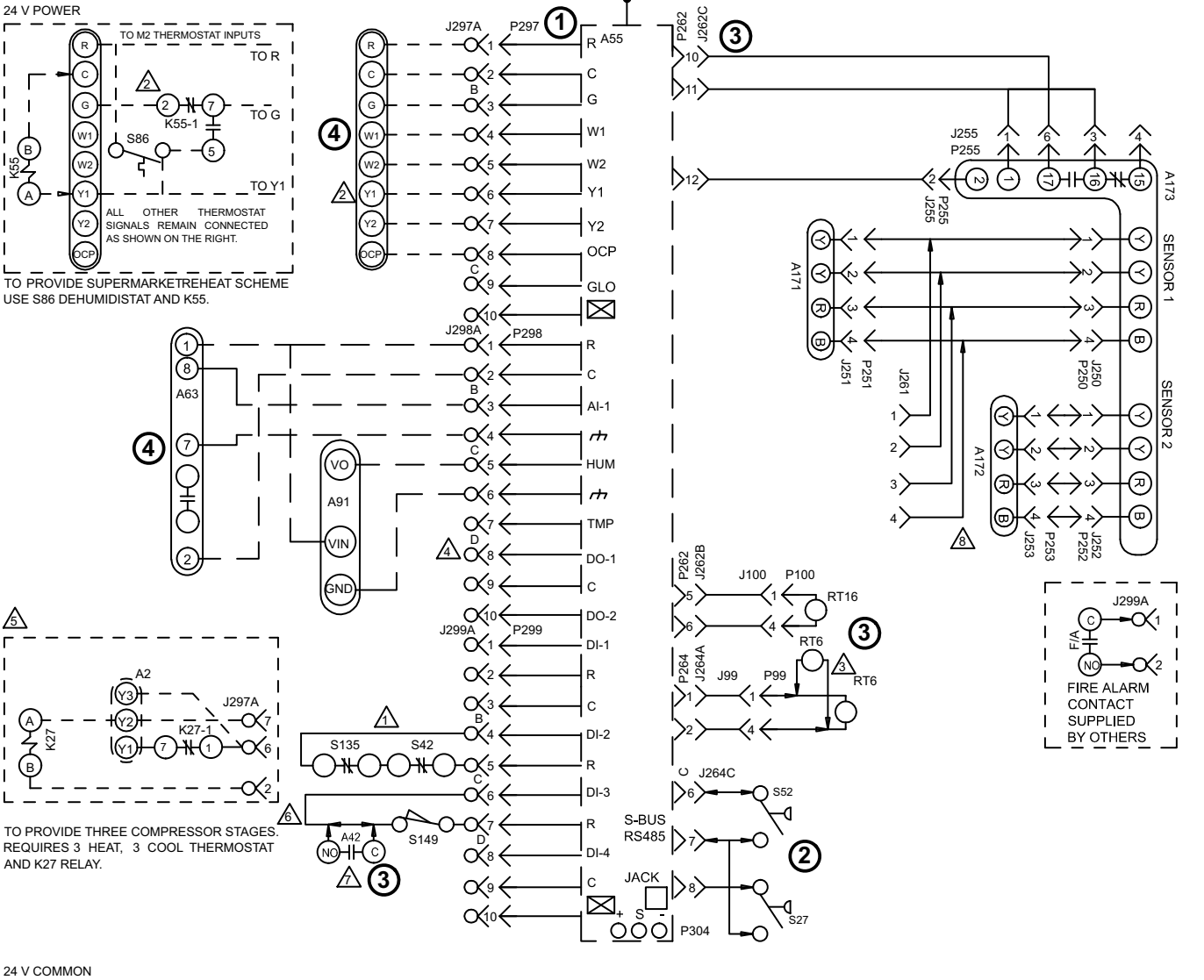

- ⚠ 1 FOR MOTORS WITH S42 AND S135 EXTERNAL OVERLOAD LESS INVERTER, SEE INVERTER WITH BY PASS FOR S42 HOOK UP
 - ⚠ 2 USE S86 DEHUMIDISTAT AND K55 FOR OPTIONAL SUPERMARKET REHEAT SCHEME, M2 PARAMETERS NEED TO BE MODIFIED UNDER THE SETTINGS MENU OR VIA UC SOFTWARE FOR SIMULTANEOUS HEATING AND COOLING.
 - ⚠ 3 REMOTE LOCATION OF RT6
 - ⚠ 4 P298-8 (DO-1) IS SERVICE RELAY OUTPUT (24VAC) IF USED CONNECT TO AN INDICATOR LIGHT
 - ⚠ 5 THERMOSTAT HOOKUP FOR PROGRAMMABLE CONFIGURATION OF THE M2 BOARD (A55).
 - ⚠ 6 M2 SETTINGS MUST BE MODIFIED WHEN A42, S42, S52, S135 OR S149 ARE INSTALLED
- DESIGNATES OPTIONAL WIRING
 CLASS II FIELD WIRING

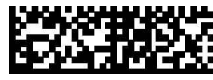
	WIRING DIAGRAM	11/09
ACCESSORIES		
ELECTRONIC OR ELECTROMECHANICAL THERMOSTAT FOR EMERGENCE™		
SECTION C		REV. 3.0
Supersedes	New Form No. 537108-01	
© 2009 Lennox Commercial		

POWER:

1. Terminal block P297 on the A55 Unit Controller energizes the thermostat components with 24VAC.

OPERATION:

2. The A55 Unit Controller proves the optional N.O. filter switch S27 (indicates dirty filter when closed) and optional N.O. air flow switch S52 (indicates no air [i.e. broken belt] system shuts down).
3. The A55 receives data from the supply and return smoke detectors A171 and A172, blower motor overload relay S42, discharge sensor RT6 and return air sensor RT16.
4. The A55 receives data from the electronic thermostat A2 (Y1, Y2, W1, W2, G, OCP) and the CO₂ sensor (if economizer is used) via terminal block P297. A55 energizes the appropriate components.

ELECTRONIC OR ELECTROMECHANICAL THERMOSTAT KEY DESCRIPTION

DESCRIPTION	
KEY	COMPONENT
A2	SENSOR, ELECTRONIC THERMOSTAT
A42	MONITOR, PHASE PROTECTOR
A55	PANEL, MAIN
A63	SENSOR, CO2 (IAQ) OPTIONAL
A91	SENSOR, HUMIDITY
A171	SENSOR ONE, SMOKE, RETURN AIR
A172	SENSOR TWO, SMOKE, SUPPLY AIR
A173	MODULE, CONTROL SMOKE DETECTION
J99	JACK, RT16 RETURN AIR SENSOR
J100	JACK, RT6 SUPPLY AIR SENSOR
J250	JACK, SMOKE DETECTOR ONE
J251	JACK, SMOKE DETECTOR ONE
J252	JACK, SMOKE DETECTOR TWO
J253	JACK, SMOKE DETECTOR TWO
J255	JACK, MODULE, CONTROL SMOKE DETECTION
J261	JACK, SUPPLY SMOKE DETECTOR JUMPER
J262	JACK, ECONOMIZER
J264	JACK, BLOWER DECK
J297	JACK, THERMOSTAT - DDC INTERFACE
J298	JACK, IAQ INTERFACE
J299	JACK, SAFETY INTERFACE
K27, -1	RELAY, TRANSFER
K55,-1	RELAY, BLOWER
P99	PLUG, RT16 RETURN AIR SENSOR
P100	PLUG, RT6 SUPPLY AIR SENSOR
P250	PLUG, SMOKE DETECTOR ONE
P251	PLUG, SMOKE DETECTOR ONE
P252	PLUG, SMOKE DETECTOR TWO
P253	PLUG, SMOKE DETECTOR TWO
P255	PLUG, MODULE, CONTROL SMOKE DETECTION
P262	PLUG, ECONOMIZER
P264	PLUG, BLOWER DECK
P297	PLUG, THERMOSTAT - DDC INTERFACE
P298	PLUG, IAQ INTERFACE
P299	PLUG, SAFETY INTERFACE
P304	PLUG, SYS BUS
RT6	SENSOR, SUPPLY AIR TEMP
RT16	SENSOR, RETURN AIR TEMP
S27	SWITCH, FILTER
S52	SWITCH, AIRFLOW
S42	SWITCH, OVERLOAD RELAY BLOWER MOTOR LO
S86	SWITCH, DEHUMIDISTAT
S135	SWITCH, OVERLOAD RELAY BLOWER MOTOR HI
S149	SWITCH, OVERFLOW

ECONOMIZER

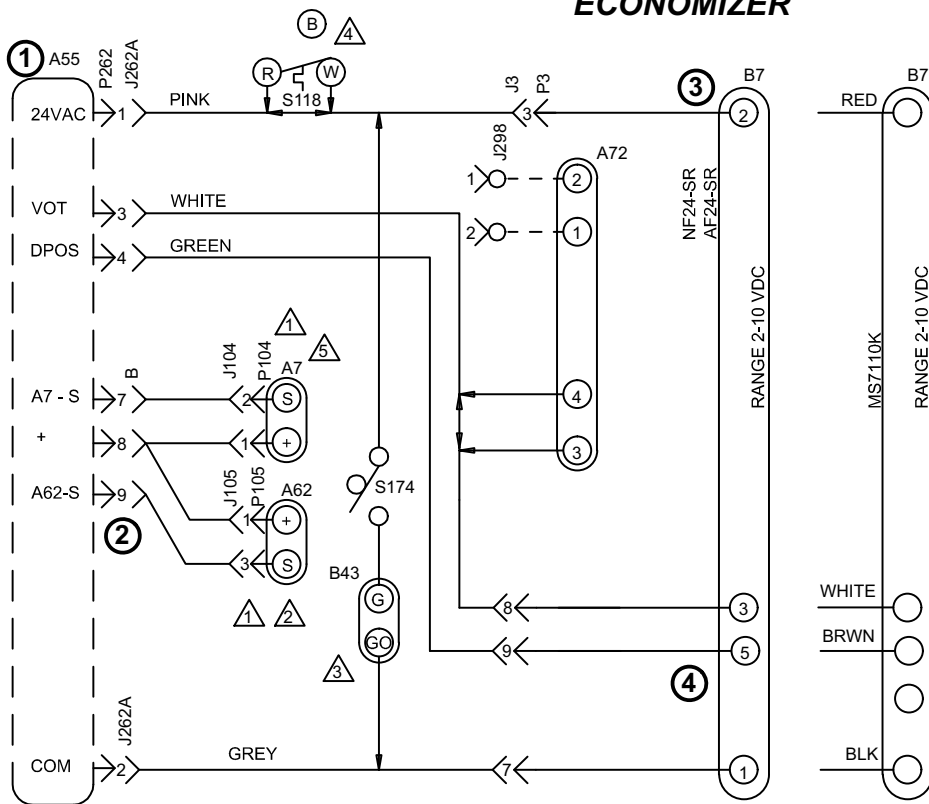

- ⚠️ DELETE A7 AND A62 (IF USED) FOR EITHER GLOBAL ENTHALPY OR SENSIBLE TEMPERATURE CONTROL
- ⚠️ FOR UNIT DIFFERENTIAL ENTHALPY CONTROL, ADD A62 RETURN AIR ENTHALPY SENSOR
- ⚠️ OPTIONAL EXHAUST DAMPER ACTUATOR TO HOLD EXHAUST DAMPER CLOSED WHEN OUTSIDE AIR DAMPER IS CLOSED
- ⚠️ S118 USED ON 35 TO 50 TON ENERGENCE UNITS WITH ENERGY RECOVERY WHEEL (ERW)

- ⚠️ REPOSITION A7 ENTHALPY SENSOR FROM ROOFTOP UNIT ECONOMIZER INTO INTAKE HOOD OF THE ERW ROOFTOP UNIT
- ⚠️ REMOVE JUMPER WHEN INSTALLING OPTIONAL LOW AMBIENT SWITCH

NOTE- THIS DIAGRAM USED ONLY WHEN ECONOMIZER OR MOTORIZED OUTDOOR AIR DAMPERS ARE INSTALLED.

DESCRIPTION	
KEY	COMPONENT
A7	SENSOR, SOLID STATE ENTHALPY
A130	CONTROL, ERS
A55	CONTROL, MAIN PANEL LENNOX
A62	SENSOR, ENTHALPY INDOOR
A72	CONTROL, REMOTE MIN POS (OPT)
B7	MOTOR, DAMPER ECONOMIZER
B43	MOTOR, EXHAUST DAMPER
J3	JACK, UNIT ECONOMIZER
J104	JACK, SENSOR OUTDOOR ENTHALPY
J105	JACK, SENSOR RETURN AIR ENTHALPY
J153	JACK, ENTHALPY / DAMPER MOTOR
J193	JACK, ENTHALPY SENSOR
J298A	JACK, IAQ INTERFACE
J262A	JACK, DAMPER MOTOR
J262B	JACK, ENTHALPY SENSORS
P3	PLUG, ECONOMIZER BYPASS
P153	PLUG, ENTHALPY / DAMPER MOTOR
P193	PLUG, ENTHALPY SENSOR
P262	PLUG, ECONOMIZER OUTPUT
S118	THERMOSTAT, DESICANT DEFROST
S174	SWITCH, EXHAUST DAMPER

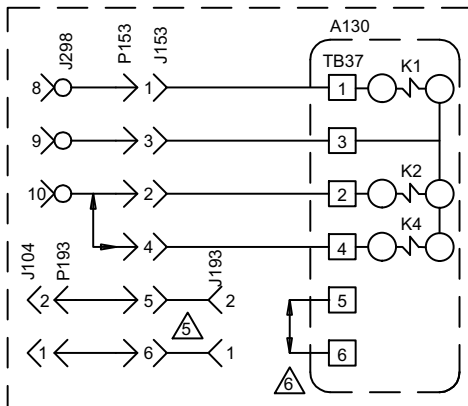

ENERGY RECOVERY WHEEL HOOK UP

— — — — — DESIGNATES OPTIONAL WIRING
 - - - - - CLASS II FIELD WIRING

WIRING DIAGRAM		09/09
ACCESSORIES		
ENERGENCE™ SERIES ECONOMIZER AND MOTORIZED OAD PIVOTING WHEEL ENERGY RECOVERY SYSTEM OPTION		
SECTION D		
Supersedes	New Form No.	
	537189-01	

© 2009

Lennox Commercial

ECONOMIZER SEQUENCE OF OPERATION

POWER:

1. A55 Unit Controller energizes the economizer components with 24VAC.

OPERATION:

2. The A55 along with outdoor enthalpy sensor A7 and indoor enthalpy sensor A62 (if differential enthalpy is used) determine when to power the damper motor B7.
3. A55 supplies B7 with 0 - 10 VDC to control the positioning of economizer.
4. The damper actuator provides 2 to 10 VDC position feedback.