

## Service Literature

### LCH156H through 300S/U

The LCH156H, 180H, 180U, 210H, 240U, 300S, 300U 13 through 25 ton (46 through 88 kW) units, are configured to order units (CTO) with a wide selection of factory installed options.

Cooling capacities range from 13 to 25 tons (45.7 to 88 kW). LCH156H, 180H, and 210H utilize three compressors while LCH180U, 240H, 240U, 300S and 300U utilize four compressors.

Optional electric heat is factory- or field-installed. Electric heat operates in single or multiple stages depending on the kW input size. 15kW to 60 kW heat sections are available for the LCH156H and 180H units and 15 kW to 90 kW heat sections are available for the LCH210H, 240H, 300S, 300U.

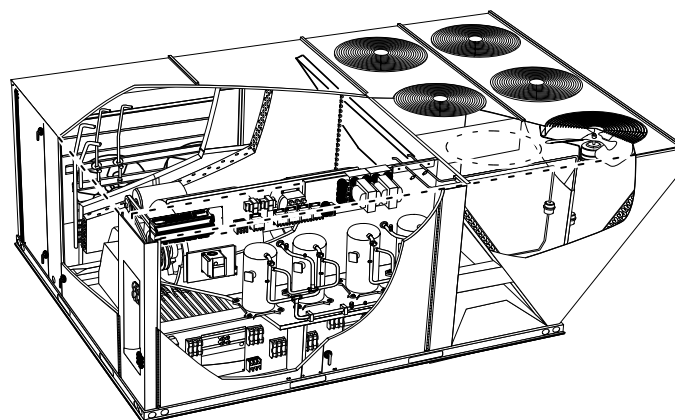
Multi-Stage Air Volume MSAV blower option is available. The VFD-driven blower will operate at lower speeds when demand is low and increase to higher speeds when demand is high.

Variable speed VAV system is available as an option which enables supply duct static measurement to control blower CFM and discharge air temperature to control cooling stages.

Units are designed to accept any of several different energy management thermostat control systems with minimum field wiring. Factory- or field-provided control options connect to the unit through Smartwire™ connectors. When "plugged in" the controls become an integral part of the unit wiring.

Information contained in this manual is intended for use by qualified service technicians only. All specifications are subject to change. Procedures outlined in this manual are presented as a recommendation only and do not supersede or replace local or state codes.

If the unit must be lifted for service, rig unit by attaching four cables to the holes located in the unit base rail (two holes at each corner). Refer to the installation instructions for the proper rigging technique.



### ⚠ WARNING

Improper installation, adjustment, alteration, service or maintenance can cause property damage, personal injury or loss of life. Installation and service must be performed by a qualified installer or service agency.

### ⚠ WARNING



Electric shock hazard. Can cause injury or death. Before attempting to perform any service or maintenance, turn the electrical power to unit OFF at disconnect switch(es). Unit may have multiple power supplies.

### Table of Contents

Options / Accessories .....	Page 2
Specifications .....	Page 9
Blower Data .....	Page 14
Electrical Data .....	Page 17
Electrical Heat Capacities .....	Page 25
Control Box Parts Arrangement .....	Page 26
Unit Parts Arrangement .....	Page 28
I Unit Components .....	Page 28
II Placement and Installation .....	Page 46
III Charging .....	Page 46
IV Start Up - Operation .....	Page 79
V System Service Checks .....	Page 82
VI Maintenance .....	Page 82
VII Accessories .....	Page 82
VIII Wiring and Operation Sequence .....	Page 97

### ⚠ CAUTION

As with any mechanical equipment, contact with sharp sheet metal edges can result in personal injury. Take care while handling this equipment and wear gloves and protective clothing.

## OPTIONS / ACCESSORIES

Item Description	Model Number	Catalog Number	Unit Model No				
			156	180	210	240	300
<b>COOLING SYSTEM</b>							
Condensate Drain Trap	PVC - C1TRAP20AD2	<b>76W26</b>	OX	OX	OX	OX	OX
	Copper - C1TRAP10AD2	<b>76W27</b>	OX	OX	OX	OX	OX
Conventional Fin/Tube Condenser Coil (replaces Environ™ Coil System)		Factory	O	O	O	O	O
Corrosion Protection		Factory	O	O	O	O	O
Drain Pan Overflow Switch	E1SNSR71AD1	<b>68W88</b>	OX	OX	OX	OX	OX
Efficiency		High	O	O	O	O	
		Standard					O
Refrigerant Type		R-410A	O	O	O	O	O
Service valves (not for Environ™ Coil System or Humiditrol® Dehumidification)		Factory	O	O	O	O	O
<b>BLOWER - SUPPLY AIR</b>							
Blower Option	CAV (Constant Air Volume)	Factory	O	O	O	O	O
	VAV (Variable Air Volume) supply air blower option (Without VFD Bypass Control)	Factory	O	O		O	
MSAV® (Multi-Stage Air Volume) supply air blower option (With VFD Bypass Control)		Factory	O	O	O	O	O
	MSAV® (Multi-Stage Air Volume) supply air blower option (Without VFD Bypass Control)	Factory	O	O	O	O	O
Motors - CAV (Constant Air Volume)	Belt Drive (standard efficiency) - 2 hp	Factory	O				
	Belt Drive (standard or high efficiency) - 3 hp	Factory	O	O	O		
	Belt Drive (standard efficiency) - 5 hp	Factory	O	O	O	O	O
	Belt Drive (standard efficiency) - 7.5 hp	Factory		O	O	O	O
	Belt Drive (standard efficiency) - 10 hp	Factory				O	O
Motors - VAV (Variable Air Volume)	Belt Drive (standard or high efficiency) - 2 hp	Factory	O				
	Belt Drive (standard or high efficiency) - 3 hp	Factory	O	O			
	Belt Drive (standard efficiency) - 5 hp	Factory	O	O		O	
	Belt Drive (standard efficiency) - 7.5 hp	Factory		O		O	
	Belt Drive (standard efficiency) - 10 hp	Factory				O	
Motors - MSAV® (Multi-Stage Air Volume)	Belt Drive (standard efficiency) - 2 hp	Factory	O				
	Belt Drive (standard efficiency) - 3 hp	Factory	O	O	O		
	Belt Drive (standard efficiency) - 5 hp	Factory	O	O	O	O	O
	Belt Drive (standard efficiency) - 7.5 hp	Factory		O	O	O	O
	Belt Drive (standard efficiency) - 10 hp	Factory				O	O
Drive Kits	Kit #1 535-725 rpm	Factory	O	O	O		
See Blower Data Tables for usage and selection	Kit #2 710-965 rpm	Factory	O	O	O		
	Kit #3 685-856 rpm	Factory	O	O	O	O	O
	Kit #4 850-1045 rpm	Factory	O	O	O	O	O
	Kit #5 945-1185 rpm	Factory	O	O	O	O	O
	Kit #6 850-1045 rpm	Factory		O	O	O	O
	Kit #7 945-1185 rpm	Factory		O	O	O	O
	Kit #8 1045-1285 rpm	Factory		O	O	O	O
	Kit #10 1045-1285 rpm	Factory				O	O
	Kit #11 1135-1365 rpm	Factory				O	O
	Blower Belt Auto-Tensioner	Factory	O	O	O	O	O
<b>CABINET</b>							
Combination Coil/ Hail Guards	Environ™ Coil System - C1GARD52C12	<b>15T92</b>	X				
	Environ™ Coil System - C1GARD52C22	<b>15T93</b>		X	X	X	X
	Conventional Fin/Tube Condenser Coil - C1GARD51C11	<b>13T08</b>	X				
	Conventional Fin/Tube Condenser Coil - C1GARD51C21	<b>13T12</b>		X	X	X	X

NOTE - Catalog and model numbers shown are for ordering field installed accessories.

OX = Configure To Order (Factory Installed) or Field Installed

O = Configure To Order (Factory Installed)

X = Field Installed

## OPTIONS / ACCESSORIES

Item Description	Model Number	Catalog Number	Unit Model No				
			156	180	210	240	300
<b>CONTROLS</b>							
Blower Proving Switch	C1SNSR35FF1	<b>53W65</b>	OX	OX	OX	OX	OX
Commercial Controls	Prodigy® Control System - BACnet® Module - C0CTRL60AE1L	59W51	OX	OX	OX	OX	OX
	Prodigy® Control System - LonTalk® Module - C0CTRL65FF1	<b>54W27</b>	OX	OX	OX	OX	OX
	Novar® LSE L Connection® Building Automation System	Factory - - -	O	O	O	O	O
Dirty Filter Switch	E1SNSR55C-1	<b>53W68</b>	OX	OX	OX	OX	OX
Fresh Air Tempering	C1SNSR75AD1	<b>58W63</b>	OX	OX	OX	OX	OX
General Purpose Control Kit	E1GPBK30C1	<b>13J78</b>	X	X	X	X	X
Smoke Detector - Supply or Return (Power board and one sensor)	C1SNSR44C-1	<b>83W40</b>	OX	OX	OX	OX	OX
Smoke Detector - Supply and Return (Power board and two sensors)	C1SNSR43C-1	<b>83W41</b>	OX	OX	OX	OX	OX
<b>INDOOR AIR QUALITY</b>							
<b>Air Filters</b>							
Healthy Climate® High Efficiency Air Filters 24 x 24 x 2 (Order 6 per unit)	MERV 8 - C1FLTR15C-1-	<b>54W67</b>	OX	OX	OX	OX	OX
	MERV 13 - C1FLTR40C-1-	<b>52W40</b>	OX	OX	OX	OX	OX
Replacement Media Filter With Metal Mesh Frame (includes non-pleated filter media)	C1FLTR30C-1-	<b>44N61</b>	OX	OX	OX	OX	OX
<b>Indoor Air Quality (CO<sub>2</sub>) Sensors</b>							
Sensor - Wall-mount, off-white plastic cover with LCD display	C0SNSR50AE1L	<b>77N39</b>	X	X	X	X	X
Sensor - Wall-mount, off-white plastic cover, no display	C0SNSR52AE1L	<b>87N53</b>	X	X	X	X	X
Sensor - Black plastic case with LCD display, rated for plenum mounting	C0SNSR51AE1L	<b>87N52</b>	X	X	X	X	X
Sensor - Wall-mount, black plastic case, no display, rated for plenum mounting	C0MISC19AE1	<b>87N54</b>	X	X	X	X	X
CO <sub>2</sub> Sensor Duct Mounting Kit - for downflow applications	C0MISC19AE1-	<b>85L43</b>	X	X	X	X	X
Aspiration Box - for duct mounting non-plenum rated CO <sub>2</sub> sensors (87N53 or 77N39)	C0MISC16AE1-	<b>90N43</b>	X	X	X	X	X
<b>UVC Germicidal Light Kit</b>							
<sup>1</sup> Healthy Climate® UVC Light Kit (110/230v-1ph)	C1UVCL10C-1	<b>54W65</b>	X	X	X	X	X
<b>ELECTRICAL</b>							
Voltage 60 hz	208/230V - 3 phase	Factory	O	O	O	O	O
	460V - 3 phase	Factory	O	O	O	O	O
	575V - 3 phase	Factory	O	O	O	O	O
Disconnect Switch (see Electric Heat Tables for usage,	80 amp - C1DISC080C-1	<b>54W85</b>	OX	OX	OX	OX	OX
	150 amp - C1DISC150C-1	<b>54W86</b>	OX	OX	OX	OX	OX
	250 amp - C1DISC250C-1	<b>54W87</b>	OX	OX	OX	OX	OX
<sup>2</sup> Short-Circuit Current Rating (SCCR) of 100kA (includes Phase/Voltage Detection)		Factory	O	O	O	O	O
GFI Service Outlets	15 amp non-powered, field-wired (208/230V, 460V, 575V) LTAGFIK10/15	<b>74M70</b>	OX	OX	OX	OX	OX
	15 amp factory-wired and powered (208/230V, 460V, 575V)	Factory	O	O	O	O	O
	20 amp non-powered, field-wired (575V only) C1GFC120FF1	<b>67E01</b>	OX	OX	OX	OX	OX
Weatherproof Cover for GFI	C1GFC199FF1	<b>10C89</b>	X	X	X	X	X
Phase/Voltage Detection (Optional for CAV options only, furnished with VAV or MSAV® option)		Factory	O	O	O	O	O

<sup>1</sup> Lamps operate on 110-230V single-phase power supply. Step-down transformer must be field supplied for field installation in 460V and 575V rooftop units (transformer is furnished for factory installed light kits). Alternately, a separate 110V power supply may be used to directly power the UVC ballast(s)

<sup>2</sup> Disconnect Switch not available with higher SCCR option. Short-Circuit Current Rating option not available on field installed electric heat or 90kW electric heat (208/240V) models.

NOTE - Catalog and model numbers shown are for ordering field installed accessories.

OX = Configure To Order (Factory Installed) or Field Installed

O = Configure To Order (Factory Installed)

X = Field Installed

## OPTIONS / ACCESSORIES

Item Description	Model Number	Catalog Number	Unit Model No				
			156	180	210	240	300
<b>ELECTRIC HEAT</b>							
15 kW	208/230V-3ph - C1EH0150C-1Y	<b>53W84</b>	OX	OX	OX	OX	OX
	460V-3ph - C1EH0150C-1G	<b>53W86</b>	OX	OX	OX	OX	OX
	575V-3ph - C1EH0150C-1J	<b>53W87</b>	OX	OX	OX	OX	OX
30 kW	208/230V-3ph - C1EH0300C11Y	<b>53W88</b>	OX				
	460V-3ph - C1EH0300C11G	<b>53W90</b>	OX				
	575V-3ph - C1EH0300C11J	<b>53W91</b>	OX				
	208/230V-3ph - C1EH0300C21Y	<b>53W92</b>		OX	OX	OX	OX
	460V-3ph - C1EH0300C21G	<b>53W94</b>		OX	OX	OX	OX
	575V-3ph - C1EH0300C21J	<b>53W95</b>		OX	OX	OX	OX
45 kW	208/230V-3ph - C1EH0450C11Y	<b>53W96</b>	OX				
	460V-3ph - C1EH0450C11G	<b>53W98</b>	OX				
	575V-3ph - C1EH0450C11J	<b>53W99</b>	OX				
	208/230V-3ph - C1EH0450C21Y	<b>54W00</b>		OX	OX	OX	OX
	460V-3ph - C1EH0450C21G	<b>54W02</b>		OX	OX	OX	OX
	575V-3ph - C1EH0450C21J	<b>54W03</b>		OX	OX	OX	OX
60 kW	208/230V-3ph - C1EH0600C11Y	<b>54W04</b>	OX				
	460V-3ph - C1EH0600C11G	<b>54W06</b>	OX				
	575V-3ph - C1EH0600C11J	<b>54W07</b>	OX				
	208/230V-3ph - C1EH0600C21Y	<b>54W08</b>		OX	OX	OX	OX
	460V-3ph - C1EH0600C21G	<b>54W10</b>		OX	OX	OX	OX
	575V-3ph - C1EH0600C21J	<b>54W11</b>		OX	OX	OX	OX
90 kW	208/230V-3ph - C1EH0900C-1Y	<b>54W12</b>			OX	OX	OX
	460V-3ph - C1EH0900C-1G	<b>54W14</b>			OX	OX	OX
	575V-3ph - C1EH0900C-1J	<b>54W15</b>			OX	OX	OX
SCR (Silicon Controlled Rectifier) Electric Heat Control		Factory	O	O	O	O	O
NOTE - The SCR option is not available with 45 kW, 60 kW and 90kW electric heat (208/230V) models.							
Thermostat (required)		<b>Y9682</b>	X	X	X	X	X
Duct Sensor (required)		<b>Y9683</b>	X	X	X	X	X
<b>ECONOMIZER</b>							
<b>High Performance Economizer (Approved for California Title 24 Building Standards / AMCA Class 1A Certified)</b>							
High Performance Economizer	E1ECON17C-2	<b>16Y98</b>	OX	OX	OX	OX	OX
Downflow or Horizontal - Includes Outdoor Air Hood.							
Order Downflow or Horizontal Barometric Relief Dampers separately.							
<b>Economizer Controls</b>							
Differential Enthalpy (Not for Title 24)	Order 2 - C1SNSR64FF1	<b>53W64</b>	OX	OX	OX	OX	OX
Sensible Control	Sensor is Furnished	Factory	O	O	O	O	O
Single Enthalpy (Not for Title 24)	C1SNSR64FF1	<b>53W64</b>	OX	OX	OX	OX	OX
Global Control	Sensor Field Provided	Factory	O	O	O	O	O
Building Pressure Control	E1GPBK20C1	<b>13J77</b>	X	X	X	X	X
Outdoor Air CFM Control	E1GPBK10C1	<b>13J76</b>	X	X	X	X	X
<b>Barometric Relief Dampers With Exhaust Hood</b>							
Downflow Barometric Relief Dampers	C1DAMP50C	<b>54W78</b>	OX	OX	OX	OX	OX
Horizontal Barometric Relief Dampers	LAGEDH18/24	<b>16K99</b>	X	X	X	X	X
<b>OUTDOOR AIR</b>							
<b>Outdoor Air Dampers With Outdoor Air Hood</b>							
Motorized	C1DAMP20C-1	<b>13U04</b>	OX	OX	OX	OX	OX
Manual	C1DAMP10C-2	<b>13U05</b>	OX	OX	OX	OX	OX

NOTE - Catalog and model numbers shown are for ordering field installed accessories.

OX = Configure To Order (Factory Installed) or Field Installed

O = Configure To Order (Factory Installed)

X = Field Installed

## OPTIONS / ACCESSORIES

Item Description	Model Number	Catalog Number	Unit Model No				
			156	180	210	240	300
<b>POWER EXHAUST</b>							
Standard Static	208/230V - C1PWRE11C-1Y	<b>75W90</b>	OX	OX	OX	OX	OX
	460V - C1PWRE11C-1G	<b>75W91</b>	OX	OX	OX	OX	OX
	575V - C1PWRE11C-1J	<b>75W92</b>	OX	OX	OX	OX	OX
SCCR, Standard Static	208/230V - C1PWRE11C-1Y	<b>75W90</b>	OX	OX	OX	OX	OX
	460V - C1PWRE11C-2G	<b>17J93</b>	OX	OX	OX	OX	OX
	575V - C1PWRE11C-2J	<b>17J98</b>	OX	OX	OX	OX	OX
<b>HUMIDITROL® CONDENSER REHEAT OPTION (CAV AND MSAV®) MODELS ONLY</b>							
Humiditrol® Dehumidification Option		Factory	O	O	O	O	O
Humidity Sensor Kit, Remote mounted (required)	C0SNSR31AE-1	<b>17M50</b>	X	X	X	X	X
<b>ROOF CURBS</b>							
<b>Hybrid Roof Curbs, Downflow</b>							
8 in. height	C1CURB70C-1	<b>11F58</b>	X	X	X	X	X
14 in. height	C1CURB71C-1	<b>11F59</b>	X	X	X	X	X
18 in. height	C1CURB72C-1	<b>11F60</b>	X	X	X	X	X
24 in. height	C1CURB73C-1	<b>11F61</b>	X	X	X	X	X
<b>Adjustable Pitch Curb</b>							
14 in. height	L1CURB55C	<b>43W26</b>	X	X	X	X	X
<b>Standard Roof Curbs, Horizontal - Requires Horizontal Return Air Panel Kit</b>							
26 in. height - slab applications	C1CURB14C-1	<b>11T89</b>	X	X	X	X	
30 in. height - slab applications	C1CURB15C-1	<b>11T90</b>					X
37 in. height - rooftop applications	C1CURB16C-1	<b>11T96</b>	X	X	X	X	
41 in. height - rooftop applications	C1CURB17C-1	<b>11T97</b>					X
<b>Insulation Kit For Standard Horizontal Roof Curbs</b>							
for C1CURB14C-1 (26 in.)	C1INSU11C-1-	<b>73K32</b>	X	X	X	X	
for C1CURB15C-1 (30 in.)	C1INSU12C-1-	<b>73K33</b>					X
for C1CURB16C-1 (37 in.)	C1INSU13C-1-	<b>73K34</b>	X	X	X	X	
for C1CURB17C-1 (41 in.)	C1INSU14C-1-	<b>73K35</b>					X
<b>Horizontal Return Air Panel Kit</b>							
Required for Horizontal Applications with Roof Curb	C1HRAP10C-1-	<b>87M00</b>	X	X	X	X	X
<b>CEILING DIFFUSERS</b>							
Step-Down - Order one	RTD11-185S	<b>13K63</b>	X	X			
	RTD11-275S	<b>13K64</b>			X	X	X
Flush - Order one	FD11-185S	<b>13K58</b>	X	X			
	FD11-275S	<b>13K59</b>			X	X	X
Transitions (Supply and Return) - Order one	C1DIFF33C-1	<b>12X68</b>	X	X			
	C1DIFF34C-1	<b>12X70</b>			X	X	X

<sup>1</sup> Order one 6 kW transformer per array (up to 24 solar modules each). Up to two arrays can be used per rooftop unit (total 48 modules). Arrays are field wired in parallel to the Solar Power Entry

NOTE - Catalog and model numbers shown are for ordering field installed accessories.

OX = Configure To Order (Factory Installed) or Field Installed

O = Configure To Order (Factory Installed)

X = Field Installed

## OPTIONS / ACCESSORIES

Item Description	Model Number	Catalog Number	Unit Model No.		
			180U	240U	300U
<b>COOLING SYSTEM</b>					
Condensate Drain Trap	PVC - C1TRAP20AD2	76W26	OX	OX	OX
	Copper - C1TRAP10AD2	76W27	OX	OX	OX
Corrosion Protection		Factory	O	O	O
Drain Pan Overflow Switch	E1SNSR71AD1	68W88	OX	OX	OX
Refrigerant Type		R-410A	O	O	O
<b>BLOWER - SUPPLY AIR</b>					
Blower	MSAV (multi-stage air volume) blower option (With VFD Bypass Control)	Factory	O	O	O
	MSAV (multi-stage air volume) blower option (Without VFD Bypass Control)	Factory	O	O	O
Motors - MSAV (multi-stage air volume)	Belt Drive (standard efficiency) - 3 hp	Factory	O		
	Belt Drive (standard efficiency) - 5 hp	Factory	O	O	O
	Belt Drive (standard efficiency) - 7.5 hp	Factory	O	O	O
	Belt Drive (standard efficiency) - 10 hp	Factory		O	O
Drive Kits See Blower Data Tables for usage and selection	Kit #1 535-725 rpm	Factory	O		
	Kit #2 710-965 rpm	Factory	O		
	Kit #3 685-856 rpm	Factory	O	O	O
	Kit #4 850-1045 rpm	Factory	O	O	O
	Kit #5 945-1185 rpm	Factory	O	O	O
	Kit #6 850-1045 rpm	Factory	O	O	O
	Kit #7 945-1185 rpm	Factory	O	O	O
	Kit #8 1045-1285 rpm	Factory	O	O	O
	Kit #10 1045-1285 rpm	Factory		O	O
	Kit #11 1135-1365 rpm	Factory		O	O
	Blower Belt Auto-Tensioner	Factory	O	O	O
<b>CABINET</b>					
Combination Coil/Hail Guards	C1GARD51C21	13T12	X	X	X
<b>CONTROLS</b>					
Blower Proving Switch	C1SNSR35FF1	53W65	OX	OX	OX
Commercial Controls	Prodigy® Control System - BACnet® Module - C0CTRL60AE1L	<b>59W51</b>	OX	OX	OX
	Prodigy® Control System - LonTalk® Module - C0CTRL65FF1	54W27	OX	OX	OX
	Novar® ETM-2051 - E0CTRL30C1	64W74	OX	OX	OX
	Novar® LSE	Factory	O	O	O
	L Connection® Building Automation System	- - -	X	X	X
Dirty Filter Switch	E1SNSR55C-1	53W68	OX	OX	OX
Fresh Air Tempering	C1SNSR75AD1	58W63	OX	OX	OX
General Purpose Control Kit	E1GPBK30C1	13J78	X	X	X
Smoke Detector - Supply or Return (Power board and one sensor)	C1SNSR44C-1	83W40	OX	OX	OX
Smoke Detector - Supply and Return (Power board and two sensors)	C1SNSR43C-1	83W41	OX	OX	OX

NOTE - Catalog and model numbers shown are for ordering field installed accessories.

OX = Configure To Order (Factory Installed) or Field Installed

O = Configure To Order (Factory Installed)

X = Field Installed

## OPTIONS / ACCESSORIES

Item Description	Model Number	Catalog Number	Unit Model No.			
			180U	240U	300U	
<b>INDOOR AIR QUALITY</b>						
<b>Air Filters</b>						
Healthy Climate® High Efficiency Air Filters 24 x 24 x 2 (Order 6 per unit)	MERV 8 - C1FLTR15C-1-	54W67	OX	OX	OX	
	MERV 13 - C1FLTR40C-1-	52W40	OX	OX	OX	
Replacement Media Filter With Metal Mesh Frame (includes non-pleated filter media)	C1FLTR30C-1-	44N61	OX	OX	OX	
<b>Indoor Air Quality (CO<sub>2</sub>) Sensors</b>						
Sensor - Wall-mount, off-white plastic cover with LCD display	C0SNSR50AE1L	77N39	X	X	X	
Sensor - Wall-mount, off-white plastic cover, no display	C0SNSR52AE1L	87N53	X	X	X	
Sensor - Black plastic case with LCD display, rated for plenum mounting	C0SNSR51AE1L	87N52	X	X	X	
Sensor - Wall-mount, black plastic case, no display, rated for plenum mounting	C0MISC19AE1	87N54	X	X	X	
CO <sub>2</sub> Sensor Duct Mounting Kit - for downflow applications	C0MISC19AE1-	85L43	X	X	X	
Aspiration Box - for duct mounting non-plenum rated CO <sub>2</sub> sensors ( <b>87N53</b> or <b>77N39</b> )	C0MISC16AE1-	90N43	X	X	X	
<b>UVC Germicidal Light Kit</b>						
<sup>1</sup> Healthy Climate® UVC Light Kit (110/230v-1ph)	C1UVCL10C-1	54W65	OX	OX	OX	
<b>ELECTRICAL</b>						
Voltage 60 hz	208/230V - 3 phase	Factory	O	O	O	
	460V - 3 phase	Factory	O	O	O	
	575V - 3 phase	Factory	O	O	O	
Disconnect Switch (see Electric Heat Tables for usage, page 27)	80 amp - C1DISC080C-1	54W85	OX	OX	OX	
	150 amp - C1DISC150C-1	54W86	OX	OX	OX	
	250 amp - C1DISC250C-1	54W87	OX	OX	OX	
<sup>2</sup> Short-Circuit Current Rating (SCCR) of 100kA (includes Phase/Voltage Detection)		Factory	O	O	O	
GFI Service Outlets	15 amp non-powered, field-wired (208/230V, 460V, 575V) 15 amp factory-wired and powered (208/230V, 460V, 575V) 20 amp non-powered, field-wired (575V only)	LTAGFIK10/15	74M70	OX	OX	OX
		C1GFC120FF1	67E01	OX	OX	OX
		C1GFC199FF1	10C89	X	X	X
<b>ELECTRIC HEAT</b>						
15 kW	208/230V-3ph - C1EH0150C-1Y	53W84	OX	OX	OX	
	460V-3ph - C1EH0150C-1G	53W86	OX	OX	OX	
	575V-3ph - C1EH0150C-1J	53W87	OX	OX	OX	
30 kW	208/230V-3ph - C1EH0300C21Y	53W92	OX	OX	OX	
	460V-3ph - C1EH0300C21G	53W94	OX	OX	OX	
	575V-3ph - C1EH0300C21J	53W95	OX	OX	OX	
45 kW	208/230V-3ph - C1EH0450C21Y	54W00	OX	OX	OX	
	460V-3ph - C1EH0450C21G	54W02	OX	OX	OX	
	575V-3ph - C1EH0450C21J	54W03	OX	OX	OX	
60 kW	208/230V-3ph - C1EH0600C21Y	54W08	OX	OX	OX	
	460V-3ph - C1EH0600C21G	54W10	OX	OX	OX	
	575V-3ph - C1EH0600C21J	54W11	OX	OX	OX	
90 kW	208/230V-3ph - C1EH0900C-1Y	54W12		OX	OX	
	460V-3ph - C1EH0900C-1G	54W14		OX	OX	
	575V-3ph - C1EH0900C-1J	54W15		OX	OX	
SCR (Silicon Controlled Rectifier) Electric Heat Control		Factory	O	O	O	
NOTE - The SCR option is not available with 45 kW, 60 kW and 90kW electric heat (208/230V) models.						
Thermostat (required)		Y9682	X	X	X	
Duct Sensor (required)		Y9683	X	X	X	

<sup>1</sup> Lamps operate on 110-230V single-phase power supply. Step-down transformer must be field supplied for field installation in 460V and 575V rooftop units (transformer is furnished for factory installed light kits). Alternately, a separate 110V power supply may be used to directly power the UVC ballast(s)

<sup>2</sup> Disconnect Switch not available with higher SCCR option. Short-Circuit Current Rating option not available on field installed electric heat or 90kW electric heat (208/240V) models.

NOTE - Catalog and model numbers shown are for ordering field installed accessories.

OX = Configure To Order (Factory Installed) or Field Installed

O = Configure To Order (Factory Installed)

X = Field Installed

## OPTIONS / ACCESSORIES

Item Description	Model Number	Catalog Number	Unit Model No.		
			180U	240U	300U
<b>ECONOMIZER</b>					
High Performance Economizer (Approved for California Title 24 Building Standards / AMCA Class 1A Certified)					
High Performance Economizer Downflow or Horizontal - Includes Outdoor Air Hood. Order Downflow or Horizontal Barometric Relief Dampers separately.	E1ECON17C-2	16Y98	OX	OX	OX
Economizer Controls					
Differential Enthalpy (Not for Title 24)	Order 2 - C1SNSR64FF1	53W64	OX	OX	OX
Sensible Control	Sensor is Furnished	Factory	O	O	O
Single Enthalpy (Not for Title 24)	C1SNSR64FF1	53W64	OX	OX	OX
Global Control	Sensor Field Provided	Factory	O	O	O
Building Pressure Control	E1GPBK10C1	13J77	X	X	X
Outdoor Air CFM Control	E1GPBK20C1	13J76	X	X	X
Barometric Relief Dampers With Exhaust Hood					
Downflow Barometric Relief Dampers	C1DAMP50C	54W78	OX	OX	OX
Horizontal Barometric Relief Dampers	LAGEDH18/24	16K99	X	X	X
<b>OUTDOOR AIR</b>					
Outdoor Air Dampers With Outdoor Air Hood					
Motorized	C1DAMP20C-1	13U04	OX	OX	OX
Manual	C1DAMP10C-2	13U05	OX	OX	OX
<b>POWER EXHAUST</b>					
Standard Static	208/230V - C1PWRE11C-1Y	75W90	OX	OX	OX
	460V - C1PWRE11C-1G	75W91	OX	OX	OX
	575V - C1PWRE11C-1J	75W92	OX	OX	OX
<b>ROOF CURBS</b>					
Hybrid Roof Curbs, Downflow					
8 in. height	C1CURB70C-1	11F58	X	X	X
14 in. height	C1CURB71C-1	11F59	X	X	X
18 in. height	C1CURB72C-1	11F60	X	X	X
24 in. height	C1CURB73C-1	11F61	X	X	X
Adjustable Pitch Curb					
14 in. height	L1CURB55C	43W26	X	X	X
Standard Roof Curbs, Horizontal - Requires Horizontal Return Air Panel Kit					
26 in. height - slab applications	C1CURB14C-1	11T89	X	X	X
37 in. height - rooftop applications	C1CURB16C-1	11T96	X	X	X
Insulation Kit For Standard Horizontal Roof Curbs					
for C1CURB14C-1	C1INSU11C-1-	73K32	X	X	X
for C1CURB16C-1	C1INSU13C-1-	73K34	X	X	X
Horizontal Return Air Panel Kit					
Required for Horizontal Applications with Roof Curb	C1HRAP10C-1-	87M00	X	X	X
<b>CEILING DIFFUSERS</b>					
Step-Down - Order one	RTD11-185S	13K63	X		
	RTD11-275S	13K64		X	X
Flush - Order one	FD11-185S	13K58	X		
	FD11-275S	13K59		X	X
Transitions (Supply and Return) - Order one	C1DIFF33C-1	12X68	X		
	C1DIFF34C-1	12X70		X	X

NOTE - Catalog and model numbers shown are for ordering field installed accessories.

OX = Configure To Order (Factory Installed) or Field Installed

O = Configure To Order (Factory Installed)

X = Field Installed



## SPECIFICATIONS

General Data		Nominal Tonnage	13 Ton	13 Ton	13 Ton
		Model Number	LCH156H4B	LCH156H4V	LCH156H4M
		Efficiency Type	High	High	High
		Blower Type	CAV (Constant Air Volume)	VAV (Variable Air Volume)	MSAV® (Multi-Stage Air Volume)
<b>Cooling Performance</b>	Gross Cooling Capacity - Btuh		154,000	152,000	154,000
	<sup>1</sup> Net Cooling Capacity - Btuh		150,000	148,000	150,000
	AHRI Rated Air Flow - cfm		5000	4600	5000
	Total Unit Power - kW		12.5	12.3	12.5
	<sup>1</sup> EER (Btuh/Watt)		12.0	12.0	12.0
	<sup>2</sup> IEER (Btuh/Watt)		13.2	14.5	14.1
<b>Refrigerant Charge</b>	Refrigerant Type		R-410A	R-410A	R-410A
	Environ™ Coil System	Circuit 1	5 lbs. 12 oz.	5 lbs. 0 oz.	5 lbs. 12 oz.
		Circuit 2	5 lbs. 4 oz.	5 lbs. 8 oz.	5 lbs. 4 oz.
		Circuit 3	5 lbs. 10 oz.	5 lbs. 0 oz.	5 lbs. 10 oz.
	Environ™ Coil System with Humiditrol®	Circuit 1	5 lbs. 14 oz.	---	5 lbs. 14 oz.
		Circuit 2	5 lbs. 8 oz.	---	5 lbs. 8 oz.
		Circuit 3	5 lbs. 12 oz.	---	5 lbs. 12 oz.
	Conventional Fin/Tube Coil Option	Circuit 1	10 lbs. 0 oz.	---	10 lbs. 0 oz.
		Circuit 2	10 lbs. 0 oz.	---	10 lbs. 0 oz.
		Circuit 3	9 lbs. 8 oz.	---	9 lbs. 8 oz.
	Conventional Fin/Tube With Humiditrol®	Circuit 1	12 lbs. 0 oz.	---	12 lbs. 0 oz.
		Circuit 2	12 lbs. 0 oz.	---	12 lbs. 0 oz.
		Circuit 3	9 lbs. 8 oz.	---	9 lbs. 8 oz.
<b>Electric Heat (kW) Available</b>			15-30-45-60		
<b>Compressor Type (number)</b>			Scroll (3)		
<b>Outdoor Coils</b>	Net face area (total) - sq. ft.		41.4	41.4	41.4
	Number of rows		1 (2)	1 (2)	1 (2)
<b>Environ™ (Fin/Tube)</b>	Fins per inch		23 (20)	23 (20)	23 (20)
	Motor - (No.) horsepower		(3) 1/3	(3) 1/3	(3) 1/3
<b>Outdoor Coil Fans</b>	Motor rpm		1075	1075	1075
	Total Motor watts		1100	1100	1100
	Diameter - (No.) in.		(3) 24	(3) 24	(3) 24
	Number of blades		3	3	3
	Total Air volume - cfm		12,000	12,000	12,000
	Net face area (total) - sq. ft.		21.4	21.4	21.4
<b>Indoor Coils</b>	Tube diameter - in.		3/8	3/8	3/8
	Number of rows		3	3	3
	Fins per inch		14	14	14
	Drain connection - No. and size		(1) 1 in. FPT	(1) 1 in. FPT	(1) 1 in. FPT
Expansion device type			Balance port TXV, removable head		
<sup>3</sup> <b>Indoor Blower and Drive Selection</b>	Nominal motor output		2 hp, 3 hp, 5 hp		
	Max. usable motor output (US)		2.3 hp, 3.45 hp, 5.75 hp		
	Motor - Drive kit number		<b>2 hp</b> Kit 1 535-725 rpm Kit 2 710-965 rpm <b>3 hp Std. Eff.</b> Kit 1 535-725 rpm Kit 2 710-965 rpm <b>3 hp High. Eff.</b> Kit 3 685-856 rpm Kit 4 850-1045 rpm <b>5 hp</b> Kit 3 - 685-856 rpm Kit 4 850-1045 rpm Kit 5 945-1185 rpm		
	Blower wheel nominal D x W - in.		(2) 15 x 15 in.	(2) 15 x 15 in.	(2) 15 x 15 in.
	Type of filter		Fiberglass, disposable		
Number and size - in.		(6) 24 x 24 x 2			
<b>Electrical characteristics</b>			208/230V, 460V or 575V - 60 hertz - 3 phase		

NOTE - Net capacity includes evaporator blower motor heat deduction. Gross capacity does not include evaporator blower motor heat deduction.

<sup>1</sup> AHRI Certified to AHRI Standard 340/360; 95°F outdoor air temperature and 80°F db/67°F wb entering evaporator air; minimum external duct static pressure.

<sup>2</sup> Integrated Energy Efficiency Ratio tested according to AHRI Standard 340/360.

<sup>3</sup> Using total air volume and system static pressure requirements determine from blower performance tables rpm and motor output required. Maximum usable output of motors furnished are shown. In Canada, nominal motor output is also maximum usable motor output. If motors of comparable output are used, be sure to keep within the service factor limitations outlined on the motor nameplate.

NOTE - Units equipped with MSAV® (Multi-Stage Air Volume) option are limited to a motor service factor of 1.0.

# SPECIFICATIONS

General Data		Nominal Tonnage	15 Ton	15 Ton	15 Ton	17.5 Ton	17.5 Ton	
		Model Number	LCH180H4B	LCH180H4V	LCH180H4M	LCH210H4B	LCH210H4M	
		Efficiency Type	High	High	High	High	High	
		Blower Type	CAV (Constant Air Volume)	VAV (Variable Air Volume)	MSAV® (Multi-Stage Air Volume)	CAV (Constant Air Volume)	MSAV® (Multi-Stage Air Volume)	
<b>Cooling Performance</b>	Gross Cooling Capacity - Btuh		176,000	176,000	176,000	204,000	204,000	
	<sup>1</sup> Net Cooling Capacity - Btuh		172,000	172,000	172,000	198,000	198,000	
	AHRI Rated Air Flow - cfm		5250	5250	5250	6125	6125	
	Total Unit Power - kW		14.3	14.3	14.3	16.5	16.5	
	<sup>1</sup> EER (Btuh/Watt)		12.0	12.0	12.0	12.0	12.0	
	<sup>2</sup> IEER (Btuh/Watt)		13.5	15.2	13.7	13.0	14.0	
<b>AHRI Reference No.</b>			202088996	203353983	202088998	202088995	202088993	
<b>Refrigerant Charge</b>		Refrigerant Type	R-410A	R-410A	R-410A	R-410A	R-410A	
Environ™ Coil System	Circuit 1	Circuit 1	6 lbs. 0 oz.	5 lbs. 4 oz.	6 lbs. 0 oz.	6 lbs. 12 oz.	6 lbs. 12 oz.	
		Circuit 2	5 lbs. 10 oz.	5 lbs. 8 oz.	5 lbs. 10 oz.	6 lbs. 14 oz.	6 lbs. 14 oz.	
		Circuit 3	5 lbs. 14 oz.	5 lbs. 8 oz.	5 lbs. 14 oz.	6 lbs. 14 oz.	6 lbs. 14 oz.	
	Environ™ Coil System with Humiditrol®	Circuit 1	Circuit 1	6 lbs. 8 oz.	---	6 lbs. 8 oz.	7 lbs. 4 oz.	7 lbs. 4 oz.
			Circuit 2	5 lbs. 12 oz.	---	5 lbs. 12 oz.	7 lbs. 0 oz.	7 lbs. 0 oz.
			Circuit 3	6 lbs. 9 oz.	---	6 lbs. 9 oz.	6 lbs. 4 oz.	6 lbs. 4 oz.
	Conventional Fin/Tube Coil Option	Circuit 1	Circuit 1	12 lbs. 8 oz.	---	12 lbs. 8 oz.	13 lbs. 0 oz.	13 lbs. 0 oz.
			Circuit 2	12 lbs. 8 oz.	---	12 lbs. 8 oz.	13 lbs. 0 oz.	13 lbs. 0 oz.
			Circuit 3	12 lbs. 8 oz.	---	12 lbs. 8 oz.	13 lbs. 0 oz.	13 lbs. 0 oz.
	Conventional Fin/Tube With Humiditrol®	Circuit 1	Circuit 1	14 lbs. 8 oz.	---	14 lbs. 8 oz.	15 lbs. 0 oz.	15 lbs. 0 oz.
			Circuit 2	14 lbs. 8 oz.	---	14 lbs. 8 oz.	15 lbs. 0 oz.	15 lbs. 0 oz.
			Circuit 3	12 lbs. 8 oz.	---	12 lbs. 8 oz.	13 lbs. 0 oz.	13 lbs. 0 oz.
	<b>Electric Heat (kW) Available</b>			15-30-45-60 kW			15-30-45-60-90 kW	
	<b>Compressor Type (number)</b>			Scroll (3)	Scroll (3)	Scroll (3)	Scroll (3)	Scroll (3)
	<b>Outdoor Coils (Environ™ (Fin/Tube))</b>	Net face area (total) - sq. ft.		55.2	55.2	55.2	55.2	55.2
Number of rows			1 (2)	1 (2)	1 (2)	1 (2)	1 (2)	
<b>Outdoor Coil Fans</b>	Fins per inch		23 (20)	23 (20)	23 (20)	23 (20)	23 (20)	
	Motor - (No.) horsepower		(4) 1/3	(4) 1/3	(4) 1/3	(6) 1/3	(6) 1/3	
	Motor rpm		1075	1075	1075	1075	1075	
	Total Motor watts		1500	1500	1500	1950	1950	
	Diameter - (No.) in.		(4) 24	(4) 24	(4) 24	(6) 24	(6) 24	
	Number of blades		3	3	3	3	3	
	Total Air volume - cfm		16,000	16,000	16,000	20,000	20,000	
<b>Indoor Coils</b>	Net face area (total) - sq. ft.		21.4	21.4	21.4	21.4	21.4	
	Tube diameter - in.		3/8	3/8	3/8	3/8	3/8	
	Number of rows		3	3	3	4	4	
	Fins per inch		14	14	14	14	14	
	Drain connection - No. and size		(1) 1 in. FPT	(1) 1 in. FPT	(1) 1 in. FPT	(1) 1 in. FPT	(1) 1 in. FPT	
<b><sup>3</sup> Indoor Blower and Drive Selection</b>	Expansion device type		Balance port TXV, removable head					
	Nominal motor output		3 hp, 5 hp, 7.5 hp					
	Max. usable motor output (US)		3.45 hp, 5.75 hp, 8.62 hp					
	Motor - Drive kit number		<b>3 hp Std. Eff.</b> Kit 1 535-725 rpm Kit 2 710-965 rpm <b>3 hp High. Eff.</b> Kit 3 - 685-856 rpm Kit 4 850-1045 rpm <b>5 hp</b> Kit 3 685-856 rpm Kit 4 850-1045 rpm Kit 5 945-1185 rpm <b>7.5 hp</b> Kit 6 850-1045 rpm Kit 7 945-1185 rpm Kit 8 1045-1285 rpm					
	Blower wheel nominal D x W - in.		(2) 15 x 15					
<b>Filters</b>	Type of filter		Fiberglass, disposable					
	Number and size - in.		(6) 24 x 24 x 2					
<b>Electrical characteristics</b>			208/230V, 460V or 575V - 60 hertz - 3 phase					

NOTE - Net capacity includes evaporator blower motor heat deduction. Gross capacity does not include evaporator blower motor heat deduction.

<sup>1</sup> AHRI Certified to AHRI Standard 340/360; 95°F outdoor air temperature and 80°F db/67°F wb entering evaporator air; minimum external duct static pressure.

<sup>2</sup> Integrated Energy Efficiency Ratio tested according to AHRI Standard 340/360.

<sup>3</sup> Using total air volume and system static pressure requirements determine from blower performance tables rpm and motor output required. Maximum usable output of motors furnished are shown. In Canada, nominal motor output is also maximum usable motor output. If motors of comparable output are used, be sure to keep within the service factor limitations outlined on the motor nameplate.

NOTE - Units equipped with MSAV® (Multi-Stage Air Volume) option are limited to a motor service factor of 1.0.

# SPECIFICATIONS

General Data		Nominal Tonnage	20 Ton	20 Ton	20 Ton
		Model Number	LCH240H4B	LCH240H4V	LCH240H4M
		Efficiency Type	High	High	High
		Blower Type	CAV (Constant Air Volume)	VAV (Variable Air Volume)	MSAV® (Multi-Stage Air Volume)
<b>Cooling Performance</b>	Gross Cooling Capacity - Btuh		238,000	238,000	238,000
	<sup>1</sup> Net Cooling Capacity - Btuh		230,000	230,000	230,000
	AHRI Rated Air Flow - cfm		6400	6400	6400
	Total Unit Power - kW		19.2	19.2	19.2
	<sup>1</sup> EER (Btuh/Watt)		12.0	12.0	12.0
	<sup>2</sup> IEER (Btuh/Watt)		13.2	16.0	14.5
<b>AHRI Reference No.</b>			202088997	203353982	202088994
<b>Refrigerant Charge</b>		Refrigerant Type	R-410A	R-410A	R-410A
Charge	Environ™ Coil System	Circuit 1	6 lbs. 4 oz.	6 lbs. 2 oz.	6 lbs. 4 oz.
		Circuit 2	6 lbs. 2 oz.	6 lbs. 6 oz.	6 lbs. 2 oz.
		Circuit 3	5 lbs. 14 oz.	6 lbs. 0 oz.	5 lbs. 14 oz.
		Circuit 4	5 lbs. 6 oz.	6 lbs. 10 oz.	5 lbs. 6 oz.
	Environ™ Coil System with Humiditrol®	Circuit 1	6 lbs. 4 oz.	---	6 lbs. 4 oz.
		Circuit 2	5 lbs. 10 oz.	---	5 lbs. 10 oz.
		Circuit 3	4 lbs. 14 oz.	---	4 lbs. 14 oz.
		Circuit 4	4 lbs. 14 oz.	---	4 lbs. 14 oz.
	Conventional Fin/Tube Coil Option	Circuit 1	10 lbs. 0 oz.	---	10 lbs. 0 oz.
		Circuit 2	10 lbs. 0 oz.	---	10 lbs. 0 oz.
		Circuit 3	10 lbs. 0 oz.	---	10 lbs. 0 oz.
		Circuit 4	8 lbs. 12 oz.	---	8 lbs. 12 oz.
	Conventional Fin/Tube With Humiditrol®	Circuit 1	12 lbs. 0 oz.	---	12 lbs. 0 oz.
		Circuit 2	12 lbs. 0 oz.	---	12 lbs. 0 oz.
		Circuit 3	10 lbs. 0 oz.	---	10 lbs. 0 oz.
		Circuit 4	8 lbs. 12 oz.	---	8 lbs. 12 oz.
<b>Electric Heat (kW) Available</b>			15-30-45-60, 90 kW		
<b>Compressor Type (number)</b>			Scroll (4)	Scroll (4)	Scroll (4)
<b>Outdoor Coils</b>	Net face area (total) - sq. ft.		55.2	55.2	55.2
	Environ™ (Fin/Tube)	Number of rows	1 (2)	1 (2)	1 (2)
		Fins per inch	23 (20)	23 (20)	23 (20)
<b>Outdoor Coil Fans</b>	Motor - (No.) horsepower		(6) 1/3	(6) 1/3	(6) 1/3
	Motor rpm - Total Motor watts		1075 - 1950	1075 - 1950	1075 - 1950
	Diameter - (No.) in. - No. of blades		(6) 24 - 3	(6) 24 - 3	(6) 24 - 3
	Total Air volume - cfm		20,000	20,000	20,000
<b>Indoor Coils</b>	Net face area (total) - sq. ft.		21.4	21.4	21.4
	Tube diameter - in.		3/8	3/8	3/8
	Number of rows		4	4	4
	Fins per inch		14	14	14
	Drain connection - No. and size		(1) 1 in. FPT	(1) 1 in. FPT	(1) 1 in. FPT
	Expansion device type		Balance port TXV, removable head		
<sup>3</sup> <b>Indoor Blower and Drive Selection</b>	Nominal motor output		5 hp, 7.5 hp, 10 hp		
	Maximum usable motor output (US Only)		5.75 hp, 8.62 hp, 11.5 hp		
	Motor - Drive kit number		<b>5 hp</b> <b>Kit 3</b> 685-856 rpm <b>Kit 4</b> 850-1045 rpm <b>Kit 5</b> 945-1185 rpm <b>7.5 hp</b> <b>Kit 6</b> 850-1045 rpm <b>Kit 7</b> 945-1185 rpm <b>Kit 8</b> 1045-1285 rpm <b>10 hp</b> <b>Kit 7</b> 945-1185 rpm <b>Kit 10</b> 1045-1285 rpm <b>Kit 11</b> 1135-1365 rpm		
	Blower wheel nom. D x W - in.		(2) 15 x 15		
<b>Filters</b>	Type of filter		Fiberglass, disposable		
	Number and size - in.		(6) 24 x 24 x 2		
<b>Electrical characteristics</b>			208/230V, 460V or 575V - 60 hertz - 3 phase		

NOTE - Net capacity includes evaporator blower motor heat deduction. Gross capacity does not include evaporator blower motor heat deduction.

<sup>1</sup> AHRI Certified to AHRI Standard 340/360; 95°F outdoor air temperature and 80°F db/67°F wb entering evaporator air; minimum external duct static pressure.

<sup>2</sup> Integrated Energy Efficiency Ratio tested according to AHRI Standard 340/360.

<sup>3</sup> Using total air volume and system static pressure requirements determine from blower performance tables rpm and motor output required. Maximum usable output of motors furnished are shown. In Canada, nominal motor output is also maximum usable motor output. If motors of comparable output are used, be sure to keep within the service factor limitations outlined on the motor nameplate.

NOTE - Units equipped with MSAV® (Multi-Stage Air Volume) option are limited to a motor service factor of 1.0.

# SPECIFICATIONS

General Data		Nominal Tonnage	25 Ton	25 Ton
		Model Number	LCH300S4B	LCH300S4M
Efficiency Type		Blower Type	Standard	Standard
		Blower Type	CAV (Constant Air Volume)	MSAV® (Multi-Stage Air Volume)
<b>Cooling Performance</b>	Gross Cooling Capacity - Btuh		281,000	281,000
	<sup>1</sup> Net Cooling Capacity - Btuh		270,000	270,000
	AHRI Rated Air Flow - cfm		8400	8400
	Total Unit Power - kW		25.7	25.7
	<sup>1</sup> EER (Btuh/Watt)		10.5	10.5
	<sup>2</sup> IEER (Btuh/Watt)		11.6	13.8
<b>Refrigerant Charge</b>		Refrigerant Type	R-410A	R-410A
Charge	Environ™ Coil System	Circuit 1	6 lbs. 4 oz.	6 lbs. 4 oz.
		Circuit 2	5 lbs. 10 oz.	5 lbs. 10 oz.
		Circuit 3	6 lbs. 6 oz.	6 lbs. 6 oz.
		Circuit 4	6 lbs. 0 oz.	6 lbs. 0 oz.
	Environ™ Coil System with Humiditrol®	Circuit 1	7 lbs. 8 oz.	7 lbs. 8 oz.
		Circuit 2	6 lbs. 4 oz.	6 lbs. 4 oz.
		Circuit 3	6 lbs. 2 oz.	6 lbs. 2 oz.
		Circuit 4	5 lbs. 14 oz.	5 lbs. 14 oz.
	Conventional Fin/Tube Coil Option	Circuit 1	10 lbs. 8 oz.	10 lbs. 8 oz.
		Circuit 2	10 lbs. 0 oz.	10 lbs. 0 oz.
		Circuit 3	9 lbs. 12 oz.	9 lbs. 12 oz.
		Circuit 4	9 lbs. 12 oz.	9 lbs. 12 oz.
	Conventional Fin/Tube With Humiditrol®	Circuit 1	12 lbs. 12 oz.	12 lbs. 12 oz.
		Circuit 2	11 lbs. 12 oz.	11 lbs. 12 oz.
		Circuit 3	9 lbs. 12 oz.	9 lbs. 12 oz.
		Circuit 4	9 lbs. 12 oz.	9 lbs. 12 oz.
<b>Electric Heat (kW) Available - See page 14</b>			15-30-45-60, 90 kW	
<b>Compressor Type (number)</b>			Scroll (4)	Scroll (4)
<b>Outdoor Coils</b>	Net face area (total) - sq. ft.		55.2	55.2
	Environ™ (Fin/Tube)	Number of rows	1 (2)	1 (2)
		Fins per inch	23 (20)	23 (20)
<b>Outdoor Coil Fans</b>	Motor - (No.) horsepower		(6) 1/3	(6) 1/3
	Motor rpm - Total Motor watts		1075 - 1950	1075 - 1950
	Diameter - (No.) in. - No. of blades		(6) 24 - 3	(6) 24 - 3
	Total Air volume - cfm		20,000	20,000
<b>Indoor Coils</b>	Net face area (total) - sq. ft.		21.4	21.4
	Tube diameter - in.		3/8	3/8
	Number of rows		4	4
	Fins per inch		14	14
	Drain connection - No. and size		(1) 1 in. FPT	(1) 1 in. FPT
		Expansion device type	Balance port TXV, removable head	
<sup>3</sup> Indoor Blower and Drive Selection	Nominal motor output		5 hp, 7.5 hp, 10 hp	
	Maximum usable motor output (US Only)		5.75 hp, 8.62 hp, 11.5 hp	
	Motor - Drive kit number		<b>5 hp</b> Kit 3 685-856 rpm Kit 4 850-1045 rpm Kit 5 945-1185 rpm <b>7.5 hp</b> Kit 6 850-1045 rpm Kit 7 945-1185 rpm Kit 8 1045-1285 rpm <b>10 hp</b> Kit 7 945-1185 rpm Kit 10 1045-1285 rpm Kit 11 1135-1365 rpm	
Blower wheel nom. D x W - in.			(2) 15 x 15	
<b>Filters</b>	Type of filter		Fiberglass, disposable	
	Number and size - in.		(6) 24 x 24 x 2	
<b>Electrical characteristics</b>			208/230V, 460V or 575V - 60 hertz - 3 phase	

NOTE - Net capacity includes evaporator blower motor heat deduction. Gross capacity does not include evaporator blower motor heat deduction.

<sup>1</sup> AHRI Certified to AHRI Standard 340/360; 95°F outdoor air temperature and 80°F db/67°F wb entering evaporator air; minimum external duct static pressure.

<sup>2</sup> Integrated Energy Efficiency Ratio tested according to AHRI Standard 340/360.

<sup>3</sup> Using total air volume and system static pressure requirements determine from blower performance tables rpm and motor output required. Maximum usable output of motors furnished are shown. In Canada, nominal motor output is also maximum usable motor output. If motors of comparable output are used, be sure to keep within the service factor limitations outlined on the motor nameplate.

NOTE - Units equipped with MSAV® (Multi-Stage Air Volume) option are limited to a motor service factor of 1.0.

## SPECIFICATIONS

General Data		15 Ton	20 Ton	25 Ton
Nominal Tonnage		15 Ton	20 Ton	25 Ton
Model Number		LCH180U4M	LCH240U4M	LCH300U4M
Efficiency Type		Ultra	Ultra	Ultra
Blower Type		MSAV (Multi-Stage Air Volume)	MSAV (Multi-Stage Air Volume)	MSAV (Multi-Stage Air Volume)
Cooling Performance	Gross Cooling Capacity - Btuh	185,300	241,000	272,000
	<sup>1</sup> Net Cooling Capacity - Btuh	180,000	234,000	265,000
	AHRI Rated Air Flow - cfm	5,200	6,400	8,400
	Total Unit Power - kW	14.2	19.5	25.2
	<sup>1</sup> EER (Btuh/Watt)	12.7	12.0	10.5
	<sup>2</sup> IEER (Btuh/Watt)	20.2	20.0	17.5
Refrigerant Charge	Refrigerant Type	R-410A	R-410A	R-410A
	Circuit 1	20 lbs. 0 oz.	21 lbs. 4 oz.	23 lbs. 8 oz.
	Circuit 2	20 lbs. 8 oz.	22 lbs. 0 oz.	21 lbs. 0 oz.
Electric Heat Available -		15-30-45-60 kW	15-30-45-60-90 kW	15-30-45-60-90 kW
Compressor Type (number)		Tandem Scroll (4)	Tandem Scroll (4)	Tandem Scroll (4)
Outdoor Coils	Net face area (total) - sq. ft.	55.2	55.2	55.2
	Tube Diameter - in.	3/8	3/8	3/8
	Number of rows	2	2	2
	Fins per inch	20	20	20
Outdoor Coil Fans	Motor - (No.) horsepower	(6) 1/3 ECM	(6) 1/3 ECM	(6) 1/3 ECM
	Motor rpm	530 - 895	590 - 955	590 - 955
	Total Motor watts	210 - 860	555 - 1740	555 - 1740
	Diameter - (No.) in.	(6) 24	(6) 24	(6) 24
	Number of blades	3	3	3
	Total Air volume - cfm	16,000	19,500	19,500
Indoor Coils	Net face area (total) - sq. ft.	21.4	21.4	21.4
	Tube diameter - in.	3/8	3/8	3/8
	Number of rows	4	4	3
	Fins per inch	14	14	14
	Drain connection - No. and size	(1) 1 in. FPT	(1) 1 in. FPT	(1) 1 in. FPT
	Expansion device type	Balance port TXV, removable head		
<sup>3</sup> Indoor Blower and Drive Selection	Nominal motor output	3 hp, 5 hp, 7.5 hp	5 hp, 7.5 hp, 10 hp	5 hp, 7.5 hp, 10 hp
	Maximum usable motor output (US Only)	3.45 hp, 5.75 hp, 8.62 hp	5.75 hp, 8.62 hp, 11.5 hp	5.75 hp, 8.62 hp, 11.5 hp
	Motor - Drive kit number	<b>3 hp Std. Eff.</b> Kit 1 535-725 rpm Kit 2 710-965 rpm <b>3 hp High. Eff.</b> Kit 3 - 685-856 rpm Kit 4 850-1045 rpm <b>5 hp</b> Kit 3 685-856 rpm Kit 4 850-1045 rpm Kit 5 945-1185 rpm <b>7.5 hp</b> Kit 6 850-1045 rpm Kit 7 945-1185 rpm Kit 8 1045-1285 rpm	<b>5 hp</b> Kit 3 685-856 rpm Kit 4 850-1045 rpm Kit 5 945-1185 rpm <b>7.5 hp</b> Kit 6 850-1045 rpm Kit 7 945-1185 rpm Kit 8 1045-1285 rpm <b>10 hp</b> Kit 7 945-1185 rpm Kit 10 1045-1285 rpm Kit 11 1135-1365 rpm	<b>5 hp</b> Kit 3 685-856 rpm Kit 4 850-1045 rpm Kit 5 945-1185 rpm <b>7.5 hp</b> Kit 6 850-1045 rpm Kit 7 945-1185 rpm Kit 8 1045-1285 rpm <b>10 hp</b> Kit 7 945-1185 rpm Kit 10 1045-1285 rpm Kit 11 1135-1365 rpm
	Blower wheel nominal D x W - in.	(2) 15 x 15	(2) 15 x 15	(2) 15 x 15
Filters	Type of filter	Fiberglass, disposable		
	Number and size - in.	(6) 24 x 24 x 2		
Electrical characteristics		208/230V, 460V or 575V - 60 hertz - 3 phase		

NOTE - Net capacity includes evaporator blower motor heat deduction. Gross capacity does not include evaporator blower motor heat deduction.

<sup>1</sup> AHRI Certified to AHRI Standard 340/360; 95°F outdoor air temperature and 80°F db/67°F wb entering evaporator air; minimum external duct static pressure.

<sup>2</sup> Integrated Energy Efficiency Ratio tested according to AHRI Standard 340/360.

<sup>3</sup> Using total air volume and system static pressure requirements determine from blower performance tables rpm and motor output required. Maximum usable output of motors furnished are shown. In Canada, nominal motor output is also maximum usable motor output. If motors of comparable output are used, be sure to keep within the service factor limitations outlined on the motor nameplate.

NOTE – MSAV® (Multi-Stage Air Volume) drive is limited to a motor service factor of 1.0.

## BLOWER DATA

### BLOWER TABLE INCLUDES RESISTANCE FOR BASE UNIT ONLY WITH DRY INDOOR COIL & AIR FILTERS IN PLACE

#### FOR ALL UNITS ADD:

- 1 - Wet indoor coil air resistance of selected unit.
- 2 - Any factory installed options air resistance (electric heat, economizer, etc.)
- 3 - Any field installed accessories air resistance (electric heat, duct resistance, diffuser, etc.)

Then determine from blower table blower motor output and drive required.

See page 15 for wet coil and option/accessory air resistance data.

See page 15 for factory installed drive kit specifications.

#### MINIMUM AIR VOLUME REQUIRED FOR USE WITH OPTIONAL ELECTRIC HEAT

LCH156H units require 5200 cfm minimum air with electric heat.

All other units require 6000 cfm minimum air with electric heat.

Air Volume cfm	TOTAL STATIC PRESSURE - Inches Water Gauge (Pa)																									
	0.20	0.40	0.60	0.80	1.00	1.20	1.40	1.60	1.80	2.00	2.20	2.40	2.60	0.20	0.40	0.60	0.80	1.00	1.20	1.40	1.60	1.80	2.00	2.20	2.40	2.60
	RPM	BHP	RPM	BHP	RPM	BHP	RPM	BHP	RPM	BHP	RPM	BHP	RPM	BHP	RPM	BHP	RPM	BHP	RPM	BHP	RPM	BHP	RPM	BHP	RPM	BHP
2750	385	0.30	505	0.50	600	0.70	680	0.90	755	1.10	820	1.30	885	1.50	950	1.70	1000	1.90	1060	2.10	1120	2.30	1180	2.50	1240	2.70
3000	395	0.35	515	0.55	610	0.75	685	1.00	760	1.20	825	1.45	890	1.65	955	1.85	1005	2.05	1065	2.25	1125	2.45	1185	2.65	1245	2.85
3250	405	0.40	520	0.60	615	0.85	695	1.10	765	1.30	830	1.60	890	1.80	955	2.00	1005	2.20	1065	2.40	1125	2.60	1185	2.80	1245	3.00
3500	415	0.45	530	0.70	620	0.95	700	1.20	775	1.45	840	1.70	900	1.90	965	2.10	1015	2.30	1075	2.50	1135	2.70	1195	2.90	1255	3.10
3750	425	0.50	540	0.75	630	1.05	710	1.30	780	1.60	845	1.85	905	2.05	970	2.25	1020	2.45	1080	2.65	1140	2.85	1200	3.05	1260	3.25
4000	435	0.55	545	0.85	635	1.10	715	1.40	785	1.70	850	2.00	910	2.20	975	2.40	1025	2.60	1085	2.80	1145	3.00	1205	3.20	1265	3.40
4250	445	0.60	555	0.90	645	1.25	725	1.55	795	1.85	855	2.15	915	2.35	980	2.55	1030	2.75	1090	2.95	1150	3.15	1210	3.35	1270	3.55
4500	455	0.70	565	1.00	655	1.35	730	1.65	800	2.00	865	2.35	925	2.55	990	2.75	1040	2.95	1100	3.15	1160	3.35	1220	3.55	1280	3.75
4750	470	0.75	575	1.10	660	1.45	740	1.80	810	2.15	870	2.50	930	2.70	995	2.90	1055	3.10	1115	3.30	1175	3.50	1235	3.70	1295	3.90
5000	480	0.85	585	1.25	670	1.60	750	1.95	815	2.30	880	2.70	940	3.00	1000	3.20	1060	3.40	1120	3.60	1180	3.80	1240	4.00	1300	4.20
5250	495	0.95	595	1.35	680	1.70	755	2.10	825	2.50	890	2.90	945	3.25	1000	3.45	1060	3.65	1120	3.85	1180	4.05	1240	4.25	1300	4.45
5500	505	1.05	605	1.45	690	1.85	765	2.25	835	2.65	895	3.05	955	3.45	1010	3.65	1070	3.85	1130	4.05	1190	4.25	1250	4.45	1310	4.65
5750	520	1.15	615	1.60	700	2.00	775	2.45	840	2.85	905	3.25	960	3.65	1015	3.85	1075	4.05	1135	4.25	1195	4.45	1255	4.65	1315	4.85
6000	530	1.30	630	1.75	710	2.15	785	2.60	850	3.05	910	3.45	970	3.90	1025	4.10	1085	4.30	1145	4.50	1205	4.70	1265	4.90	1325	5.10
6250	545	1.40	640	1.90	720	2.35	795	2.80	860	3.25	920	3.70	975	4.15	1030	4.35	1090	4.55	1150	4.75	1210	4.95	1270	5.15	1330	5.35
6500	560	1.55	650	2.05	730	2.50	805	3.00	870	3.45	930	3.95	985	4.40	1040	4.60	1100	4.80	1160	5.00	1220	5.20	1280	5.40	1340	5.60
6750	570	1.70	665	2.20	745	2.70	815	3.20	880	3.70	940	4.20	995	4.65	1045	4.85	1105	5.05	1165	5.25	1225	5.45	1285	5.65	1345	5.85
7000	585	1.85	675	2.35	755	2.90	825	3.40	890	3.95	950	4.45	1005	4.90	1055	5.10	1115	5.30	1175	5.50	1235	5.70	1295	5.90	1355	6.10
7250	600	2.00	690	2.60	765	3.10	835	3.65	900	4.15	955	4.65	1015	5.25	1065	5.45	1125	5.65	1185	5.85	1245	6.05	1305	6.25	1365	6.45
7500	615	2.20	700	2.75	775	3.30	845	3.85	910	4.45	965	4.95	1020	5.50	1075	5.70	1135	5.90	1195	6.10	1255	6.30	1315	6.50	1375	6.70
7750	630	2.40	715	3.00	790	3.55	855	4.10	920	4.70	975	5.25	1030	5.80	1080	6.00	1140	6.20	1200	6.40	1260	6.60	1320	6.80	1380	7.00
8000	640	2.55	725	3.20	800	3.80	865	4.35	930	4.95	985	5.50	1040	6.10	1090	6.30	1150	6.50	1210	6.70	1270	6.90	1330	7.10	1390	7.30
8250	655	2.80	740	3.40	810	4.00	880	4.65	940	5.25	995	5.85	1050	6.45	1100	6.65	1160	6.85	1220	7.05	1280	7.25	1340	7.45	1400	7.65
8500	670	3.00	750	3.65	825	4.30	890	4.90	950	5.55	1005	6.15	1060	6.80	1110	7.00	1170	7.20	1230	7.40	1290	7.60	1350	7.80	1410	8.00
8750	685	3.25	765	3.90	835	4.55	900	5.20	960	5.85	1015	6.45	1070	7.15	1120	7.35	1180	7.55	1240	7.75	1300	7.95	1360	8.15	1420	8.35
9000	700	3.50	780	4.20	850	4.85	910	5.50	970	6.15	1025	6.80	1080	7.50	1130	7.70	1190	7.90	1250	8.10	1310	8.30	1370	8.50	1430	8.70
9250	715	3.75	790	4.45	860	5.15	925	5.85	985	6.55	1040	7.20	1090	7.85	1140	8.05	1200	8.25	1260	8.45	1320	8.65	1380	8.85	1440	9.05
9500	730	4.00	805	4.75	875	5.45	935	6.15	995	6.90	1050	7.60	1100	8.25	1150	8.45	1210	8.65	1270	8.85	1330	9.05	1390	9.25	1450	9.45
9750	745	4.30	820	5.05	885	5.75	950	6.55	1005	7.20	1060	7.95	1110	8.65	1160	8.85	1220	9.05	1280	9.25	1340	9.45	1400	9.65	1460	9.85
10,000	760	4.60	835	5.40	900	6.15	960	6.85	1015	7.60	1070	8.35	1120	9.05	1170	9.25	1230	9.45	1290	9.65	1350	9.85	1410	10.05	1470	10.25
10,250	775	4.90	845	5.65	910	6.45	970	7.20	1030	8.00	1080	8.75	1135	9.55	1180	10.25	1225	11.00	1275	11.75	1325	12.50	1375	13.25	1425	14.00
10,500	790	5.20	860	6.00	925	6.85	985	7.65	1040	8.40	1095	9.20	1145	10.00	1190	10.70	1235	11.45	1290	12.20	1340	13.00	1390	13.75	1440	14.50
10,750	805	5.55	875	6.40	940	7.25	1000	8.05	1055	8.85	1105	9.65	1155	10.45	1200	11.20	1255	12.20	1305	13.00	1355	13.75	1405	14.50	1465	15.25
11,000	820	5.90	890	6.80	950	7.60	1010	8.45	1065	9.30	1115	10.05	1165	10.90	1210	11.90	1265	13.15	1315	14.10	1365	15.05	1415	15.95	1475	16.75

# BLOWER DATA

## FACTORY INSTALLED BELT DRIVE KIT SPECIFICATIONS

Motor Efficiency	Nominal hp	Maximum hp	Drive Kit Number	RPM Range
Standard or High	2	2.30	1	535 - 725
Standard or High	2	2.30	2	710 - 965
Standard	3	3.45	1	535 - 725
Standard	3	3.45	2	710 - 965
High	3	3.45	3	685 - 856
High	3	3.45	4	850 - 1045
Standard	5	5.75	3	685 - 856
Standard	5	5.75	4	850 - 1045
Standard	5	5.75	5	945 - 1185
Standard	7.5	8.63	6	850 - 1045
Standard	7.5	8.63	7	945 - 1185
Standard	7.5	8.63	8	1045 - 1285
Standard	10	11.50	7	945 - 1185
Standard	10	11.50	10	1045 - 1285
Standard	10	11.50	11	1135 - 1365

NOTE - Using total air volume and system static pressure requirements determine from blower performance tables rpm and motor output required. Maximum usable output of motors furnished are shown. In Canada, nominal motor output is also maximum usable motor output. If motors of comparable output are used, be sure to keep within the service factor limitations outlined on the motor nameplate.

NOTE - Units equipped with MSAV® (Multi-Stage Air Volume) option are limited to a motor service factor of 1.0.

## FACTORY INSTALLED OPTIONS/FIELD INSTALLED ACCESSORY AIR RESISTANCE

Air Volume cfm	Wet Indoor Coil		Humiditrol® Condenser Reheat Coil	Electric Heat	Economizer	Filters		Horizontal Roof Curb	
	156H, 180H	210H, 240H 300S				MERV 8	MERV 13	156H thru 240H	300S
	in. w.g.	in. w.g.	in. w.g.	in. w.g.	in. w.g.			in. w.g.	
2750	.01	.02	.01	---	---	.01	.03	.03	-
3000	.01	.02	.01	---	---	.01	.03	.04	-
3250	.01	.03	.01	---	---	.01	.04	.04	.01
3500	.01	.03	.02	---	---	.01	.04	.05	.01
3750	.01	.03	.02	---	---	.01	.04	.05	.01
4000	.02	.04	.02	---	---	.01	.04	.06	.02
4250	.02	.04	.02	---	---	.01	.05	.07	.02
4500	.02	.05	.02	---	---	.01	.05	.07	.02
4750	.02	.05	.02	---	---	.02	.05	.08	.03
5000	.02	.05	.02	---	---	.02	.06	.08	.03
5250	.02	.06	.03	---	---	.02	.06	.09	.04
5500	.02	.07	.03	---	---	.02	.06	.10	.04
5750	.03	.07	.03	---	---	.02	.07	.11	.05
6000	.03	.08	.03	.01	---	.03	.07	.11	.06
6250	.03	.08	.03	.01	.01	.03	.07	.12	.07
6500	.03	.09	.04	.01	.02	.03	.08	.13	.08
6750	.04	.10	.04	.01	.03	.03	.08	.14	.08
7000	.04	.10	.04	.01	.04	.04	.08	.15	.09
7250	.04	.11	.04	.01	.05	.04	.09	.16	.10
7500	.05	.12	.05	.01	.06	.04	.09	.17	.11
8000	.05	.13	.05	.02	.09	.05	.10	.19	.13
8500	.06	.15	.05	.02	.11	.05	.10	.21	.15
9000	.07	.16	.06	.04	.14	.06	.11	.24	.17
9500	.08	.18	.07	.05	.16	.07	.12	.26	.19
10,000	.08	.20	.07	.06	.19	.07	.12	.29	.21
10,500	.09	.22	.08	.09	.22	.08	.13	.31	.24
11,000	.11	.24	.08	.11	.25	.09	.14	.34	.27

## BLOWER DATA

### POWER EXHAUST FAN PERFORMANCE

Return Air System Static Pressure	Air Volume Exhausted
in. w.g.	cfm
0.00	8630
0.05	8210
0.10	7725
0.15	7110
0.20	6470
0.25	5790
0.30	5060
0.35	4300
0.40	3510
0.45	2690
0.50	1840

### CEILING DIFFUSER AIR RESISTANCE - in. w.g.

Air Volume cfm	Step-Down Diffuser						Flush Diffuser	
	RTD11-185S			RTD11-275			FD11-185S	FD11-275
	2 Ends Open	1 Side/2 Ends Open	All Ends & Sides Open	2 Ends Open	1 Side/2 Ends Open	All Ends & Sides Open		
5000	.51	.44	.39	---	---	---	.27	---
5200	.56	.48	.42	---	---	---	.30	---
5400	.61	.52	.45	---	---	---	.33	---
5600	.66	.56	.48	---	---	---	.36	---
5800	.71	.59	.51	---	---	---	.39	---
6000	.76	.63	.55	.36	.31	.27	.42	.29
6200	.80	.68	.59	---	---	---	.46	---
6400	.86	.72	.63	---	---	---	.50	---
6500	---	---	---	.42	.36	.31	---	.34
6600	.92	.77	.67	---	---	---	.54	---
6800	.99	.83	.72	---	---	---	.58	---
7000	1.03	.87	.76	.49	.41	.36	.62	.40
7200	1.09	.92	.80	---	---	---	.66	---
7400	1.15	.97	.84	---	---	---	.70	---
7500	---	---	---	.51	.46	.41	---	.45
7600	1.20	1.02	.88	---	---	---	.74	---
8000	---	---	---	.59	.49	.43	---	.50
8500	---	---	---	.69	.58	.50	---	.57
9000	---	---	---	.79	.67	.58	---	.66
9500	---	---	---	.89	.75	.65	---	.74
10,000	---	---	---	1.00	.84	.73	---	.81
10,500	---	---	---	1.10	.92	.80	---	.89
11,000	---	---	---	1.21	1.01	.88	---	.96

### CEILING DIFFUSER AIR THROW DATA - ft.

Model No.	Air Volume cfm	<sup>1</sup> Effective Throw Range - ft.		Model No.	Air Volume cfm	<sup>1</sup> Effective Throw Range - ft.	
		RTD11-185S Step-Down	FD11-185S Flush			RTD11-275S Step-Down	FD11-275S Flush
156 180	5600	39 - 49	28 - 37	210 240 300	7200	33 - 38	26 - 35
	5800	42 - 51	29 - 38		7400	35 - 40	28 - 37
	6000	44 - 54	40 - 50		7600	36 - 41	29 - 38
	6200	45 - 55	42 - 51		7800	38 - 43	40 - 50
	6400	46 - 55	43 - 52		8000	39 - 44	42 - 51
	6600	47 - 56	45 - 56		8200	41 - 46	43 - 52
					8400	43 - 49	44 - 54
					8600	44 - 50	46 - 57
					8800	47 - 55	48 - 59

<sup>1</sup> Throw is the horizontal or vertical distance an airstream travels on leaving the outlet diffuser before the maximum velocity is reduced to 50 ft. per minute. Four sides open.



**ELECTRICAL/ELECTRIC HEAT DATA**

**13 TON**

**13 TON HIGH EFFICIENCY**

**LCH156H4**

<sup>1</sup> Voltage - 60hz		208/230V - 3 Ph			460V - 3 Ph			575V - 3 Ph		
Compressor 1	Rated Load Amps	14.5			6.3			6.0		
	Locked Rotor Amps	98			55			41		
Compressor 2	Rated Load Amps	14.5			6.3			6		
	Locked Rotor Amps	98			55			41		
Compressor 3	Rated Load Amps	14.5			6.3			6		
	Locked Rotor Amps	98			55			41		
Outdoor Fan Motors (3)	Full Load Amps (total)	2.4 (7.2)			1.3 (3.9)			1 (3)		
Power Exhaust (2) 0.33 HP	Full Load Amps (total)	2.4 (4.8)			1.3 (2.6)			1 (2)		
Service Outlet 115V GFI (amps)		15			15			20		
Indoor Blower Motor	Horsepower	2	3	5	2	3	5	2	3	5
	Full Load Amps	7.5	10.6	16.7	3.4	4.8	7.6	2.7	3.9	6.1
<sup>2</sup> Maximum Overcurrent Protection	Unit Only	70	70	80	30	35	35	30	30	30
	With (2) 0.33 HP Power Exhaust	80	80	90	35	35	40	30	30	35
<sup>3</sup> Minimum Circuit Ampacity	Unit Only	62	65	72	28	30	33	26	27	29
	With (2) 0.33 HP Power Exhaust	67	70	77	31	32	35	28	29	31

**ELECTRIC HEAT DATA**

		Electric Heat Voltage	208V	240V	208V	240V	208V	240V	480V	480V	480V	600V	600V	600V
<sup>2</sup> Maximum Overcurrent Protection	Unit+ Electric Heat	15 kW	70	70	70	70	80	80	30	35	35	30	30	30
		30 kW	<sup>4</sup> 90	100	<sup>4</sup> 100	110	<sup>4</sup> 100	125	50	60	60	40	45	45
		45 kW	150	150	150	150	<sup>4</sup> 150	175	80	80	80	60	60	70
		60 kW	<sup>4</sup> 150	175	<sup>4</sup> 150	175	<sup>4</sup> 150	175	80	80	90	70	70	70
<sup>3</sup> Minimum Circuit Ampacity	Unit+ Electric Heat	15 kW	62	62	65	65	72	72	28	30	33	26	27	29
		30 kW	88	100	92	104	100	112	50	52	55	40	41	44
		45 kW	127	145	131	149	139	157	72	74	78	58	60	62
		60 kW	135	154	139	158	146	166	77	79	82	62	63	66
<sup>2</sup> Maximum Overcurrent Protection	Unit+ Electric Heat and (2) 0.33 HP Power Exhaust	15 kW	80	80	80	80	90	90	35	35	40	30	30	35
		30 kW	<sup>4</sup> 100	110	<sup>4</sup> 100	110	<sup>4</sup> 110	125	60	60	60	45	45	50
		45 kW	<sup>4</sup> 150	175	<sup>4</sup> 150	175	<sup>4</sup> 150	175	80	80	90	70	70	70
		60 kW	<sup>4</sup> 150	175	<sup>4</sup> 150	175	175	175	80	90	90	70	70	70
<sup>3</sup> Minimum Circuit Ampacity	Unit+ Electric Heat and (2) 0.33 HP Power Exhaust	15 kW	67	67	70	70	77	77	31	32	36	28	29	31
		30 kW	94	106	98	110	106	118	53	55	58	42	44	47
		45 kW	133	151	137	155	145	163	76	77	81	61	62	65
		60 kW	141	160	145	164	152	172	80	82	85	64	66	68

NOTE - All units have a minimum Short Circuit Current Rating (SCCR) of 5000 amps.

<sup>1</sup> Extremes of operating range are plus and minus 10% of line voltage.

<sup>2</sup> HACR type breaker or fuse.

<sup>3</sup> Refer to National or Canadian Electrical Code manual to determine wire, fuse and disconnect size requirements.

<sup>4</sup> Factory installed circuit breaker not available.

**ELECTRICAL/ELECTRIC HEAT DATA**

**15 TON**

**15 TON HIGH EFFICIENCY**

**LCH180H4**

<sup>1</sup> Voltage - 60hz		208/230V - 3 Ph			460V - 3 Ph			575V - 3 Ph		
Compressor 1	Rated Load Amps	13.2			6.3			4.9		
	Locked Rotor Amps	93			60			41		
Compressor 2	Rated Load Amps	13.2			6.3			4.9		
	Locked Rotor Amps	93			60			41		
Compressor 3	Rated Load Amps	13.2			6.3			4.9		
	Locked Rotor Amps	93			60			41		
Outdoor Fan Motors (8)	Full Load Amps (total)	2.4 (9.6)			1.3 (5.2)			1 (4)		
Power Exhaust (2) 0.33 HP	Full Load Amps (total)	2.4 (4.8)			1.3 (2.6)			1 (2)		
Service Outlet 115V GFI (amps)		15			15			20		
Indoor Blower Motor	Horsepower	3	5	7.5	3	5	7.5	3	5	7.5
	Full Load Amps	10.6	16.7	24.2	4.8	7.6	11	3.9	6.1	9
<sup>2</sup> Maximum Overcurrent Protection	Unit Only	70	80	100	35	40	45	25	30	35
	With (2) 0.33 HP Power Exhaust	80	90	100	35	40	50	30	30	40
<sup>3</sup> Minimum Circuit Ampacity	Unit Only	64	71	80	31	34	38	24	27	30
	With (2) 0.33 HP Power Exhaust	68	75	85	34	37	41	26	29	32

**ELECTRIC HEAT DATA**

Electric Heat Voltage		208V	240V	208V	240V	208V	240V	480V	480V	480V	600V	600V	600V	
<sup>2</sup> Maximum Overcurrent Protection	Unit+ Electric Heat	15 kW	70	70	80	80	100	100	35	40	45	25	30	35
		30 kW	<sup>4</sup> 100	110	<sup>4</sup> 100	125	<sup>4</sup> 110	125	60	60	60	45	45	50
		45 kW	150	150	<sup>4</sup> 150	175	<sup>4</sup> 150	175	80	80	90	60	70	70
		60 kW	<sup>4</sup> 150	175	<sup>4</sup> 150	175	175	175	80	90	90	70	70	70
<sup>3</sup> Minimum Circuit Ampacity	Unit+ Electric Heat	15 kW	64	64	71	71	80	80	31	34	38	24	27	30
		30 kW	92	104	100	112	109	121	52	55	59	41	44	48
		45 kW	131	149	139	157	148	166	74	78	82	60	62	66
		60 kW	139	158	146	166	156	175	79	82	86	63	66	69
<sup>2</sup> Maximum Overcurrent Protection	Unit+ Electric Heat and (2) 0.33 HP Power Exhaust	15 kW	80	80	90	90	100	100	35	40	50	30	30	40
		30 kW	<sup>4</sup> 100	110	<sup>4</sup> 110	125	<sup>4</sup> 125	150	60	60	70	45	50	50
		45 kW	<sup>4</sup> 150	175	<sup>4</sup> 150	175	175	175	80	90	90	70	70	70
		60 kW	<sup>4</sup> 150	175	175	175	<sup>4</sup> 175	200	90	90	90	70	70	80
<sup>3</sup> Minimum Circuit Ampacity	Unit+ Electric Heat and (2) 0.33 HP Power Exhaust	15 kW	68	68	75	75	85	85	34	37	41	26	29	32
		30 kW	98	110	106	118	115	127	55	58	63	44	47	50
		45 kW	137	155	145	163	154	172	77	81	85	62	65	68
		60 kW	145	164	152	172	162	181	82	85	90	66	68	72

NOTE - All units have a minimum Short Circuit Current Rating (SCCR) of 5000 amps.

<sup>1</sup> Extremes of operating range are plus and minus 10% of line voltage.

<sup>2</sup> HACR type breaker or fuse.

<sup>3</sup> Refer to National or Canadian Electrical Code manual to determine wire, fuse and disconnect size requirements.

<sup>4</sup> Factory installed circuit breaker not available.

**ELECTRICAL/ELECTRIC HEAT DATA**

**17.5 TON**

**17.5 TON HIGH EFFICIENCY**

**LCH210H4B/M**

<sup>1</sup> Voltage - 60hz		208/230V - 3 Ph			460V - 3 Ph			575V - 3 Ph		
Compressor 1	Rated Load Amps	15.6			7.8			5.8		
	Locked Rotor Amps	110			52			38.9		
Compressor 2	Rated Load Amps	15.6			7.8			5.8		
	Locked Rotor Amps	110			52			38.9		
Compressor 3	Rated Load Amps	19.6			8.2			6.6		
	Locked Rotor Amps	136			66.1			55.3		
Outdoor Fan Motors (3)	Full Load Amps (total)	2.4 (14.4)			1.3 (7.8)			1 (6)		
Power Exhaust (2) 0.33 HP	Full Load Amps (total)	2.4 (4.8)			1.3 (2.6)			1 (2)		
Service Outlet 115V GFI (amps)		15			15			15		
Indoor Blower Motor	Horsepower	3	5	7.5	3	5	7.5	3	5	7.5
	Full Load Amps	10.6	16.7	24.2	4.8	7.6	11	3.9	6.1	9
<sup>2</sup> Maximum Overcurrent Protection	Unit Only	100	100	110	45	45	50	35	35	40
	With (2) 0.33 HP Power Exhaust	100	110	110	45	50	50	35	40	45
<sup>3</sup> Minimum Circuit Ampacity	Unit Only	81	87	96	39	42	46	30	32	36
	With (2) 0.33 HP Power Exhaust	86	92	101	42	44	48	32	34	38

**ELECTRIC HEAT DATA**

		Electric Heat Voltage	208V	240V	208V	240V	208V	240V	480V	480V	480V	600V	600V	600V
<sup>2</sup> Maximum Overcurrent Protection	Unit+ Electric Heat	15 kW	100	100	100	100	110	110	45	45	50	35	35	40
		30 kW	<sup>4</sup> 100	110	<sup>4</sup> 100	125	<sup>4</sup> 110	125	60	60	60	45	45	50
		45 kW	150	150	<sup>4</sup> 150	175	<sup>4</sup> 150	175	80	80	90	60	70	70
		60 kW	<sup>4</sup> 150	175	<sup>4</sup> 150	175	175	175	80	90	90	70	70	70
		90 kW	<sup>4</sup> 225	250	<sup>4</sup> 225	250	<sup>4</sup> 225	250	125	125	125	100	100	100
<sup>3</sup> Minimum Circuit Ampacity	Unit+ Electric Heat	15 kW	81	81	87	87	96	96	39	42	46	30	32	36
		30 kW	92	104	100	112	109	121	52	55	59	41	44	48
		45 kW	131	149	139	157	148	166	74	78	82	60	62	66
		60 kW	139	158	146	166	156	175	79	82	86	63	66	69
		90 kW	201	230	209	238	218	247	115	118	123	92	95	98
<sup>2</sup> Maximum Overcurrent Protection	Unit+ Electric Heat and (2) 0.33 HP Power Exhaust	15 kW	100	100	110	110	110	110	45	50	50	35	40	45
		30 kW	<sup>4</sup> 100	110	<sup>4</sup> 110	125	<sup>4</sup> 125	150	60	60	70	45	50	50
		45 kW	<sup>4</sup> 150	175	<sup>4</sup> 150	175	175	175	80	90	90	70	70	70
		60 kW	<sup>4</sup> 150	175	175	175	<sup>4</sup> 175	200	90	90	90	70	70	80
		90 kW	<sup>4</sup> 225	250	<sup>4</sup> 225	250	<sup>4</sup> 225	<sup>4</sup> 300	125	125	150	100	100	110
<sup>3</sup> Minimum Circuit Ampacity	Unit+ Electric Heat and (2) 0.33 HP Power Exhaust	15 kW	86	86	92	92	101	101	42	44	48	32	34	38
		30 kW	98	110	106	118	115	127	55	58	63	44	47	50
		45 kW	137	155	145	163	154	172	77	81	85	62	65	68
		60 kW	145	164	152	172	162	181	82	85	90	66	68	72
		90 kW	207	236	215	244	224	253	118	122	126	94	97	101

NOTE - All units have a minimum Short Circuit Current Rating (SCCR) of 5000 amps.

<sup>1</sup> Extremes of operating range are plus and minus 10% of line voltage.

<sup>2</sup> HACR type breaker or fuse.

<sup>3</sup> Refer to National or Canadian Electrical Code manual to determine wire, fuse and disconnect size requirements.

<sup>4</sup> Factory installed circuit breaker not available.

**ELECTRICAL/ELECTRIC HEAT DATA**

**20 TON**

**20 TON HIGH EFFICIENCY**

**LCH240H4**

<sup>1</sup> Voltage - 60hz		208/230V - 3 Ph			460V - 3 Ph			575V - 3 Ph		
Compressor 1	Rated Load Amps	13.2			6.3			4.9		
	Locked Rotor Amps	93			60			41		
Compressor 2	Rated Load Amps	13.2			6.3			4.9		
	Locked Rotor Amps	93			60			41		
Compressor 3	Rated Load Amps	13.2			6.3			4.9		
	Locked Rotor Amps	93			60			41		
Compressor 4	Rated Load Amps	13.2			6.3			4.9		
	Locked Rotor Amps	93			60			41		
Outdoor Fan Motors (6)	Full Load Amps (total)	2.4 (14.4)			1.3 (7.8)			1 (6)		
Power Exhaust (2) 0.33 HP	Full Load Amps (total)	2.4 (4.8)			1.3 (2.6)			1 (2)		
Service Outlet 115V GFI (amps)		15			15			20		
Indoor Blower Motor	Horsepower	5	7.5	10	5	7.5	10	5	7.5	10
	Full Load Amps	16.7	24.2	30.8	7.6	11	14	6.1	9	11
<sup>2</sup> Maximum Overcurrent Protection	Unit Only	100	110	125	50	50	60	35	45	50
	With (2) 0.33 HP Power Exhaust	100	125	125	50	60	60	40	45	50
<sup>3</sup> Minimum Circuit Ampacity	Unit Only	89	98	106	43	47	51	34	37	40
	With (2) 0.33 HP Power Exhaust	93	103	111	46	50	54	36	39	42

**ELECTRIC HEAT DATA**

		Electric Heat Voltage	208V	240V	208V	240V	208V	240V	480V	480V	480V	600V	600V	600V
<sup>2</sup> Maximum Overcurrent Protection	Unit+ Electric Heat	15 kW	100	100	110	110	125	125	50	50	60	35	45	50
		30 kW	<sup>4</sup> 100	125	<sup>4</sup> 110	125	<sup>4</sup> 125	150	60	60	70	45	50	50
		45 kW	<sup>4</sup> 150	175	<sup>4</sup> 150	175	175	175	80	90	90	70	70	70
		60 kW	<sup>4</sup> 150	175	175	175	<sup>4</sup> 175	200	90	90	90	70	70	80
		90 kW	<sup>4</sup> 225	250	<sup>4</sup> 225	250	<sup>4</sup> 250	<sup>4</sup> 300	125	125	150	100	100	110
<sup>3</sup> Minimum Circuit Ampacity	Unit+ Electric Heat	15 kW	89	89	98	98	106	106	43	47	51	34	37	40
		30 kW	100	112	109	121	117	129	55	59	63	44	48	50
		45 kW	139	157	148	166	156	174	78	82	86	62	66	68
		60 kW	146	166	156	175	164	183	82	86	90	66	69	72
		90 kW	209	238	218	247	227	256	118	123	126	95	98	101
<sup>2</sup> Maximum Overcurrent Protection	Unit+ Electric Heat and (2) 0.33 HP Power Exhaust	15 kW	100	100	125	125	125	125	50	60	60	40	45	50
		30 kW	<sup>4</sup> 110	125	<sup>4</sup> 125	150	<sup>4</sup> 125	150	60	70	70	50	50	60
		45 kW	<sup>4</sup> 150	175	175	175	<sup>4</sup> 175	200	90	90	90	70	70	80
		60 kW	175	175	<sup>4</sup> 175	200	<sup>4</sup> 175	200	90	90	100	70	80	80
		90 kW	<sup>4</sup> 225	250	<sup>4</sup> 225	<sup>4</sup> 300	<sup>4</sup> 250	<sup>4</sup> 300	125	150	150	100	110	110
<sup>3</sup> Minimum Circuit Ampacity	Unit+ Electric Heat and (2) 0.33 HP Power Exhaust	15 kW	93	93	103	103	111	111	46	50	54	36	39	42
		30 kW	106	118	115	127	123	135	58	63	66	47	50	53
		45 kW	145	163	154	172	162	180	81	85	89	65	68	71
		60 kW	152	172	162	181	170	189	85	90	93	68	72	74
		90 kW	215	244	224	253	233	262	122	126	130	97	101	103

NOTE - All units have a minimum Short Circuit Current Rating (SCCR) of 5000 amps.

<sup>1</sup> Extremes of operating range are plus and minus 10% of line voltage.

<sup>2</sup> HACR type breaker or fuse.

<sup>3</sup> Refer to National or Canadian Electrical Code manual to determine wire, fuse and disconnect size requirements.

<sup>4</sup> Factory installed circuit breaker not available.

**ELECTRICAL/ELECTRIC HEAT DATA**

**25 TON**

**25 TON STANDARD EFFICIENCY**

**LCH300S4B/M**

<sup>1</sup> Voltage - 60hz		208/230V - 3 Ph			460V - 3 Ph			575V - 3 Ph		
Compressor 1	Rated Load Amps	19.6			8.2			6.6		
	Locked Rotor Amps	136			66.1			55.3		
Compressor 2	Rated Load Amps	19.6			8.2			6.6		
	Locked Rotor Amps	136			66.1			55.3		
Compressor 3	Rated Load Amps	22.4			10.6			7.7		
	Locked Rotor Amps	149			75			54		
Compressor 4	Rated Load Amps	22.4			10.6			7.7		
	Locked Rotor Amps	149			75			54		
Outdoor Fan Motors (6)	Full Load Amps (total)	2.4 (14.4)			1.3 (7.8)			1 (6)		
Power Exhaust (2) 0.33 HP	Full Load Amps (total)	2.4 (4.8)			1.3 (2.6)			1 (2)		
Service Outlet 115V GFI (amps)		15			15			20		
Indoor Blower Motor	Horsepower	5	7.5	10	5	7.5	10	5	7.5	10
	Full Load Amps	16.7	24.2	30.8	7.6	11	14	6.1	9	11
<sup>2</sup> Maximum Overcurrent Protection	Unit Only	125	150	150	60	70	70	50	50	50
	With (2) 0.33 HP Power Exhaust	150	150	150	60	70	70	50	50	60
<sup>3</sup> Minimum Circuit Ampacity	Unit Only	121	129	137	56	60	63	45	46	49
	With (2) 0.33 HP Power Exhaust	126	134	142	59	62	66	45	48	51

**ELECTRIC HEAT DATA**

		Electric Heat Voltage	208V	240V	208V	240V	208V	240V	480V	480V	480V	600V	600V	600V
<sup>2</sup> Maximum Overcurrent Protection	Unit+ Electric Heat	15 kW	125	125	150	150	150	150	60	70	70	50	50	50
		30 kW	125	125	150	150	150	150	60	70	70	50	50	50
		45 kW	<sup>4</sup> 150	175	<sup>4</sup> 150	175	175	175	80	90	90	70	70	70
		60 kW	<sup>4</sup> 150	175	175	175	<sup>4</sup> 175	200	90	90	90	70	70	80
		90 kW	<sup>4</sup> 225	250	<sup>4</sup> 225	250	<sup>4</sup> 250	<sup>4</sup> 300	125	125	150	100	100	110
<sup>3</sup> Minimum Circuit Ampacity	Unit+ Electric Heat	15 kW	121	121	129	129	137	137	56	60	63	45	46	49
		30 kW	121	121	129	129	137	137	56	60	63	45	46	49
		45 kW	139	157	148	166	156	174	78	82	86	62	66	68
		60 kW	146	166	156	175	164	183	82	86	90	66	69	72
		90 kW	209	238	218	247	227	256	118	123	126	95	98	101
<sup>2</sup> Maximum Overcurrent Protection	Unit+ Electric Heat and (2) 0.33 HP Power Exhaust	15 kW	150	150	150	150	150	150	60	70	70	50	50	60
		30 kW	150	150	150	150	150	150	60	70	70	50	50	60
		45 kW	<sup>4</sup> 150	175	175	175	<sup>4</sup> 175	200	90	90	90	70	70	80
		60 kW	175	175	<sup>4</sup> 175	200	<sup>4</sup> 175	200	90	90	100	70	80	80
		90 kW	<sup>4</sup> 225	250	<sup>4</sup> 225	<sup>4</sup> 300	<sup>4</sup> 250	<sup>4</sup> 300	125	150	150	100	110	110
<sup>3</sup> Minimum Circuit Ampacity	Unit+ Electric Heat and (2) 0.33 HP Power Exhaust	15 kW	126	126	134	134	142	142	59	62	66	45	48	51
		30 kW	126	126	134	134	142	142	59	62	66	45	48	51
		45 kW	145	163	154	172	162	180	81	85	89	65	68	71
		60 kW	152	172	162	181	170	189	85	90	93	68	72	74
		90 kW	215	244	224	253	233	262	122	126	130	97	101	103

NOTE - All units have a minimum Short Circuit Current Rating (SCCR) of 5000 amps.

<sup>1</sup> Extremes of operating range are plus and minus 10% of line voltage.

<sup>2</sup> HACR type breaker or fuse.

<sup>3</sup> Refer to National or Canadian Electrical Code manual to determine wire, fuse and disconnect size requirements.

<sup>4</sup> Factory installed circuit breaker not available.

**ELECTRICAL/ELECTRIC HEAT DATA**

**15 TON**

**15 TON ULTRA HIGH EFFICIENCY (R-410A)**

**LCH180U4M**

<sup>1</sup> Voltage - 60hz		208/230V - 3 Ph			460V - 3 Ph			575V - 3 Ph		
Compressor 1	Rated Load Amps	13.1			6.1			4.4		
	Locked Rotor Amps	83.1			41			33		
Compressor 2	Rated Load Amps	13.1			6.1			4.4		
	Locked Rotor Amps	83.1			41			33		
Compressor 3	Rated Load Amps	13.1			6.1			4.4		
	Locked Rotor Amps	83.1			41			33		
Compressor 4	Rated Load Amps	13.1			6.1			4.4		
	Locked Rotor Amps	83.1			41			33		
Outdoor Fan Motors (6)	Full Load Amps (total)	2.8 (16.8)			1.4 (8.4)			1.1 (6.6)		
Power Exhaust (2) 0.33 HP	Full Load Amps (total)	2.4 (4.8)			1.3 (2.6)			1 (2)		
Service Outlet 115V GFI (amps)		15			15			20		
Indoor Blower Motor	Horsepower	3	5	7.5	3	5	7.5	3	5	7.5
	Full Load Amps	10.6	16.7	24.2	4.8	7.6	11	3.9	6.1	9
<sup>2</sup> Maximum Overcurrent Protection	Unit Only	90	100	110	45	45	50	30	35	40
	With (2) 0.33 HP Power Exhaust	100	110	125	45	50	60	35	35	45
<sup>3</sup> Minimum Circuit Ampacity	Unit Only	84	91	100	40	43	47	30	32	36
	With (2) 0.33 HP Power Exhaust	88	95	105	42	45	50	32	34	38

**ELECTRIC HEAT DATA**

Electric Heat Voltage		208V	240V	208V	240V	208V	240V	480V	480V	480V	600V	600V	600V	
<sup>2</sup> Maximum Overcurrent Protection	Unit+ Electric Heat	15 kW	90	90	100	100	110	110	45	45	50	30	35	40
		30 kW	<sup>4</sup> 100	110	<sup>4</sup> 100	125	<sup>4</sup> 110	125	60	60	60	45	45	50
		45 kW	150	150	<sup>4</sup> 150	175	<sup>4</sup> 150	175	80	80	90	60	70	70
		60 kW	<sup>4</sup> 150	175	<sup>4</sup> 150	175	175	175	80	90	90	70	70	70
<sup>3</sup> Minimum Circuit Ampacity	Unit+ Electric Heat	15 kW	84	84	91	91	100	100	40	43	47	30	32	36
		30 kW	92	104	100	112	109	121	52	55	59	41	44	48
		45 kW	131	149	139	157	148	166	74	78	82	60	62	66
		60 kW	139	158	146	166	156	175	79	82	86	63	66	69
<sup>2</sup> Maximum Overcurrent Protection	Unit+ Electric Heat and (2) 0.33 HP Power Exhaust	15 kW	100	100	110	110	125	125	45	50	60	35	35	45
		30 kW	<sup>4</sup> 100	110	<sup>4</sup> 110	125	<sup>4</sup> 125	150	60	60	70	45	50	50
		45 kW	<sup>4</sup> 150	175	<sup>4</sup> 150	175	175	175	80	90	90	70	70	70
		60 kW	<sup>4</sup> 150	175	175	175	<sup>4</sup> 175	200	90	90	90	70	70	80
<sup>3</sup> Minimum Circuit Ampacity	Unit+ Electric Heat and (2) 0.33 HP Power Exhaust	15 kW	88	88	95	95	105	105	42	45	50	32	34	38
		30 kW	98	110	106	118	115	127	55	58	63	44	47	50
		45 kW	137	155	145	163	154	172	77	81	85	62	65	68
		60 kW	145	164	152	172	162	181	82	85	90	66	68	72

NOTE - All units have a minimum Short Circuit Current Rating (SCCR) of 5000 amps.

<sup>1</sup> Extremes of operating range are plus and minus 10% of line voltage.

<sup>2</sup> HACR type breaker or fuse.

<sup>3</sup> Refer to National or Canadian Electrical Code manual to determine wire, fuse and disconnect size requirements.

<sup>4</sup> Factory installed circuit breaker not available.

**ELECTRICAL/ELECTRIC HEAT DATA**

**20 TON**

**20 TON ULTRA HIGH EFFICIENCY (R-410A)**

**LCH240U4M**

<sup>1</sup> Voltage - 60hz		208/230V - 3 Ph			460V - 3 Ph			575V - 3 Ph		
Compressor 1	Rated Load Amps	13.5			8			5		
	Locked Rotor Amps	109			59			40		
Compressor 2	Rated Load Amps	13.5			8			5		
	Locked Rotor Amps	109			59			40		
Compressor 3	Rated Load Amps	13.5			8			5		
	Locked Rotor Amps	109			59			40		
Compressor 4	Rated Load Amps	13.5			8			5		
	Locked Rotor Amps	109			59			40		
Outdoor Fan Motors (6)	Full Load Amps (total)	2.8 (16.8)			1.4 (8.4)			1.1 (6.6)		
Power Exhaust (2) 0.33 HP	Full Load Amps (total)	2.4 (4.8)			1.3 (2.6)			1 (2)		
Service Outlet 115V GFI (amps)		15			15			20		
Indoor Blower Motor	Horsepower	5	7.5	10	5	7.5	10	5	7.5	10
	Full Load Amps	16.7	24.2	30.8	7.6	11	14	6.1	9	11
<sup>2</sup> Maximum Overcurrent Protection	Unit Only	100	125	125	50	60	70	40	45	50
	With (2) 0.33 HP Power Exhaust	110	125	125	60	60	70	40	45	50
<sup>3</sup> Minimum Circuit Ampacity	Unit Only	92	102	110	50	55	58	35	38	41
	With (2) 0.33 HP Power Exhaust	97	106	115	53	57	61	37	40	43

**ELECTRIC HEAT DATA**

Electric Heat Voltage		208V	240V	208V	240V	208V	240V	480V	480V	480V	600V	600V	600V
<sup>2</sup> Maximum Overcurrent Protection	Unit+ 15 kW	100	100	125	125	125	125	50	60	70	40	45	50
	Electric Heat 30 kW	<sup>4</sup> 100	125	125	125	<sup>4</sup> 125	150	60	60	70	45	50	50
	45 kW	<sup>4</sup> 150	175	<sup>4</sup> 150	175	175	175	80	90	90	70	70	70
	60 kW	<sup>4</sup> 150	175	175	175	<sup>4</sup> 175	200	90	90	90	70	70	80
	90 kW	<sup>4</sup> 225	250	<sup>4</sup> 225	250	<sup>4</sup> 250	<sup>4</sup> 300	125	125	150	100	100	110
<sup>3</sup> Minimum Circuit Ampacity	Unit+ 15 kW	92	92	102	102	110	110	50	55	58	35	38	41
	Electric Heat 30 kW	100	112	109	121	117	129	55	59	63	44	48	50
	45 kW	139	157	148	166	156	174	78	82	86	62	66	68
	60 kW	146	166	156	175	164	183	82	86	90	66	69	72
	90 kW	209	238	218	247	227	256	118	123	126	95	98	101
<sup>2</sup> Maximum Overcurrent Protection	Unit+ 15 kW	110	110	125	125	125	125	60	60	70	40	45	50
	Electric Heat and (2) 0.33 HP Power Exhaust 30 kW	<sup>4</sup> 110	125	<sup>4</sup> 125	150	<sup>4</sup> 125	150	60	70	70	50	50	60
	45 kW	<sup>4</sup> 150	175	175	175	<sup>4</sup> 175	200	90	90	90	70	70	80
	60 kW	175	175	<sup>4</sup> 175	200	<sup>4</sup> 175	200	90	90	100	70	80	80
	90 kW	<sup>4</sup> 225	250	<sup>4</sup> 225	<sup>4</sup> 300	<sup>4</sup> 250	<sup>4</sup> 300	125	150	150	100	110	110
<sup>3</sup> Minimum Circuit Ampacity	Unit+ 15 kW	97	97	106	106	115	115	53	57	61	37	40	43
	Electric Heat and (2) 0.33 HP Power Exhaust 30 kW	106	118	115	127	123	135	58	63	66	47	50	53
	45 kW	145	163	154	172	162	180	81	85	89	65	68	71
	60 kW	152	172	162	181	170	189	85	90	93	68	72	74
	90 kW	215	244	224	253	233	262	122	126	130	97	101	103

NOTE - All units have a minimum Short Circuit Current Rating (SCCR) of 5000 amps.

<sup>1</sup> Extremes of operating range are plus and minus 10% of line voltage.

<sup>2</sup> HACR type breaker or fuse.

<sup>3</sup> Refer to National or Canadian Electrical Code manual to determine wire, fuse and disconnect size requirements.

<sup>4</sup> Factory installed circuit breaker not available.

**ELECTRICAL/ELECTRIC HEAT DATA**

**25 TON**

**25 TON ULTRA HIGH EFFICIENCY (R-410A)**

**LCH300U4M**

<sup>1</sup> Voltage - 60hz		208/230V - 3 Ph			460V - 3 Ph			575V - 3 Ph		
Compressor 1	Rated Load Amps	19.6			8.2			6.6		
	Locked Rotor Amps	136			66.1			55.3		
Compressor 2	Rated Load Amps	19.6			8.2			6.6		
	Locked Rotor Amps	136			66.1			55.3		
Compressor 3	Rated Load Amps	19.6			8.2			6.6		
	Locked Rotor Amps	136			66.1			55.3		
Compressor 4	Rated Load Amps	19.6			8.2			6.6		
	Locked Rotor Amps	136			66.1			55.3		
Outdoor Fan Motors (6)	Full Load Amps (total)	2.8 (16.8)			1.4 (8.4)			1.1 (6.6)		
Power Exhaust (2) 0.33 HP	Full Load Amps (total)	2.4 (4.8)			1.3 (2.6)			1 (2)		
Service Outlet 115V GFI (amps)		15			15			20		
Indoor Blower Motor	Horsepower	5	7.5	10	5	7.5	10	5	7.5	10
	Full Load Amps	16.7	24.2	30.8	7.6	11	14	6.1	9	11
<sup>2</sup> Maximum Overcurrent Protection	Unit Only	125	150	150	60	60	70	45	50	50
	With (2) 0.33 HP Power Exhaust	125	150	150	60	60	70	45	50	50
<sup>3</sup> Minimum Circuit Ampacity	Unit Only	117	126	134	51	55	59	41	45	47
	With (2) 0.33 HP Power Exhaust	122	131	139	54	58	62	43	47	49

**ELECTRIC HEAT DATA**

Electric Heat Voltage		208V	240V	208V	240V	208V	240V	480V	480V	480V	600V	600V	600V	
<sup>2</sup> Maximum Overcurrent Protection	Unit+ Electric Heat	15 kW	125	125	150	150	150	150	60	60	70	45	50	50
		30 kW	125	125	150	150	150	150	60	60	70	45	50	50
		45 kW	<sup>4</sup> 150	175	<sup>4</sup> 150	175	175	175	80	90	90	70	70	70
		60 kW	<sup>4</sup> 150	175	175	175	<sup>4</sup> 175	200	90	90	90	70	70	80
		90 kW	<sup>4</sup> 225	250	<sup>4</sup> 225	250	<sup>4</sup> 250	<sup>4</sup> 300	125	125	150	100	100	110
<sup>3</sup> Minimum Circuit Ampacity	Unit+ Electric Heat	15 kW	117	117	126	126	134	134	51	55	59	41	45	47
		30 kW	117	117	126	126	134	134	55	59	63	44	48	50
		45 kW	139	157	148	166	156	174	78	82	86	62	66	68
		60 kW	146	166	156	175	164	183	82	86	90	66	69	72
		90 kW	209	238	218	247	227	256	118	123	126	95	98	101
<sup>2</sup> Maximum Overcurrent Protection	Unit+ Electric Heat and (2) 0.33 HP Power Exhaust	15 kW	125	125	150	150	150	150	60	60	70	45	50	50
		30 kW	125	125	150	150	150	150	60	70	70	50	50	60
		45 kW	<sup>4</sup> 150	175	175	175	<sup>4</sup> 175	200	90	90	90	70	70	80
		60 kW	175	175	<sup>4</sup> 175	200	<sup>4</sup> 175	200	90	90	100	70	80	80
		90 kW	<sup>4</sup> 225	250	<sup>4</sup> 225	<sup>4</sup> 300	<sup>4</sup> 250	<sup>4</sup> 300	125	150	150	100	110	110
<sup>3</sup> Minimum Circuit Ampacity	Unit+ Electric Heat and (2) 0.33 HP Power Exhaust	15 kW	122	122	131	131	139	139	54	58	62	43	47	49
		30 kW	122	122	131	131	139	139	58	63	66	47	50	53
		45 kW	145	163	154	172	162	180	81	85	89	65	68	71
		60 kW	152	172	162	181	170	189	85	90	93	68	72	74
		90 kW	215	244	224	253	233	262	122	126	130	97	101	103

NOTE - All units have a minimum Short Circuit Current Rating (SCCR) of 5000 amps.

<sup>1</sup> Extremes of operating range are plus and minus 10% of line voltage.

<sup>2</sup> HACR type breaker or fuse.

<sup>3</sup> Refer to National or Canadian Electrical Code manual to determine wire, fuse and disconnect size requirements.

<sup>4</sup> Factory installed circuit breaker not available.



## ELECTRIC HEAT CAPACITIES

Volts Input	15 kW			30 kW			45 kW			60 kW			90 kW		
	kW Input	Btuh Output	No. of Stages	kW Input	Btuh Output	No. of Stages	kW Input	Btuh Output	No. of Stages	kW Input	Btuh Output	No. of Stages	kW Input	Btuh Output	No. of Stages
208	11.3	38,600	1	22.5	76,800	1	33.8	115,300	2	45.0	153,600	2	67.6	230,700	2
220	12.6	43,000	1	25.2	86,000	1	37.8	129,000	2	50.4	172,000	2	75.6	258,000	2
230	13.8	47,100	1	27.5	93,900	1	41.3	141,000	2	55.1	188,000	2	82.7	282,200	2
240	15.0	51,200	1	30.0	102,400	1	45.0	153,600	2	60.0	204,800	2	90.0	307,100	2
440	12.6	43,000	1	25.2	86,000	1	37.8	129,000	2	50.4	172,000	2	75.6	258,000	2
460	13.8	47,100	1	27.5	93,900	1	41.3	141,000	2	55.1	188,000	2	82.7	282,200	2
480	15.0	51,200	1	30.0	102,400	1	45.0	153,600	2	60.0	204,800	2	90.0	307,100	2
550	12.6	43,000	1	25.2	86,000	1	37.8	129,000	2	50.4	172,000	2	75.6	258,000	2
575	13.8	47,100	1	27.5	93,900	1	41.3	141,000	2	55.1	188,000	2	82.7	282,200	2
600	15.0	51,200	1	30.0	102,400	1	45.0	153,600	2	60.0	204,800	2	90.0	307,100	2

# CONTROL BOX PARTS ARRANGEMENT

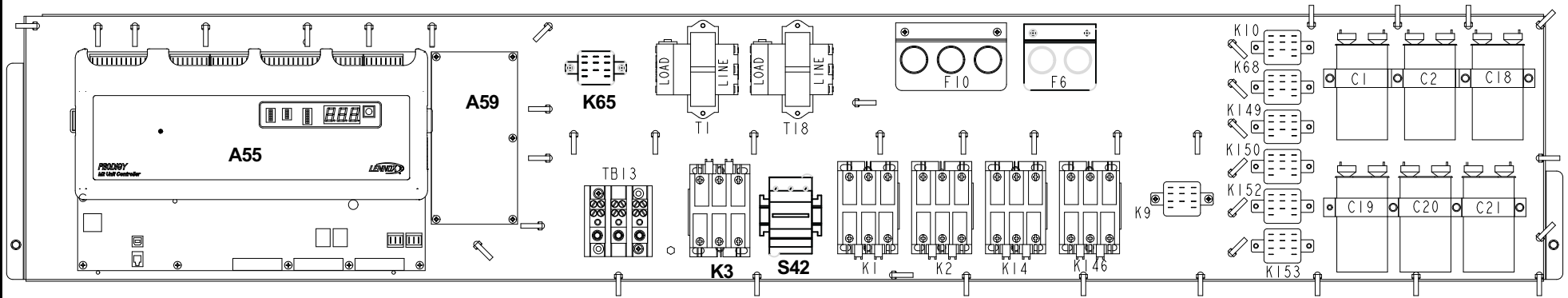


FIGURE 1

## CONTROL BOX PARTS ARRANGEMENT (ADD ONS FOR 180U & 240U, 300U)

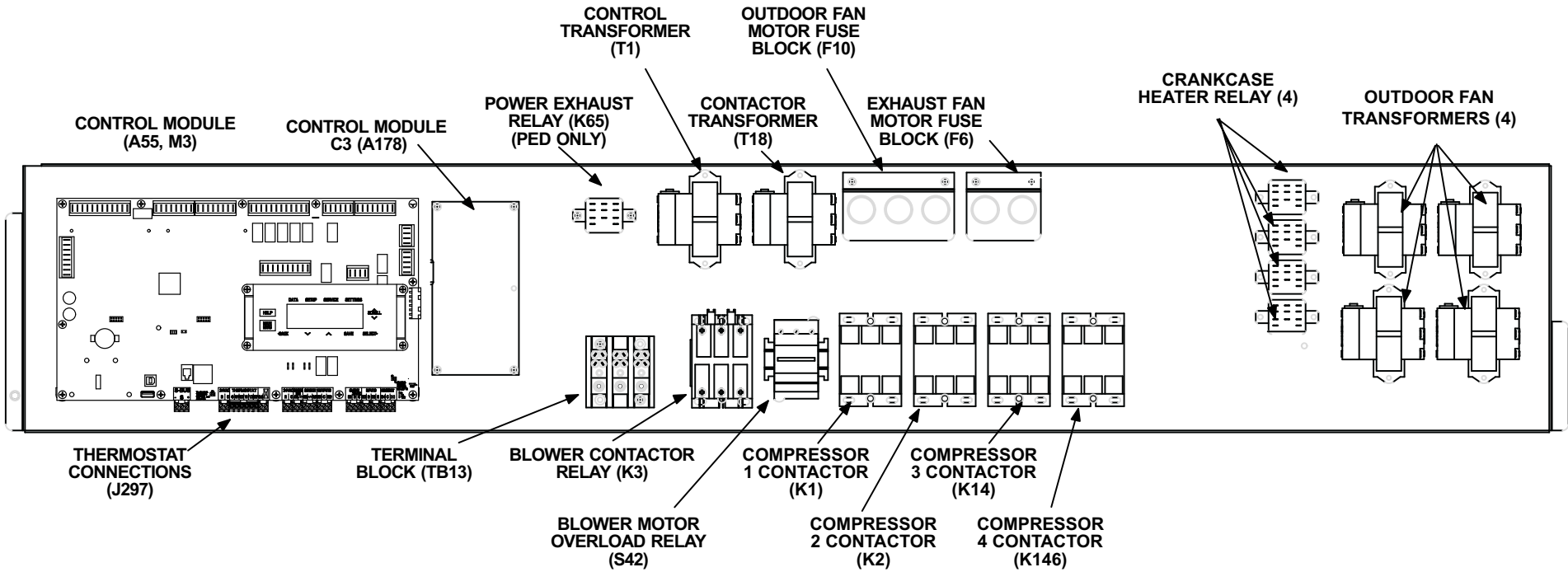
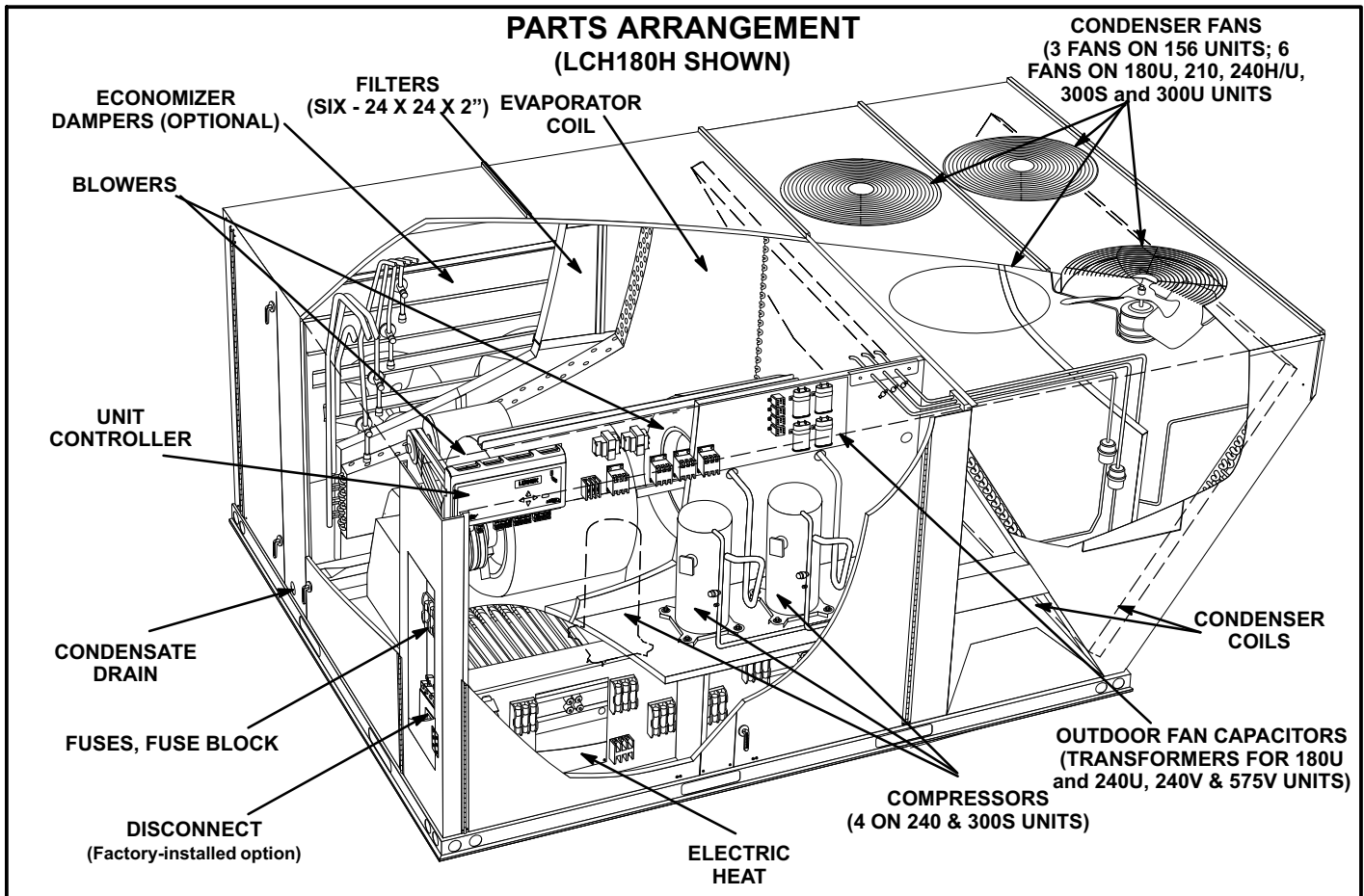


FIGURE 2



**FIGURE 3**

## I-UNIT COMPONENTS

All 13 through 25 ton (46 through 88 kW) units are configured to order units (CTO). Unit components are shown in figures 3. All units come standard with hinged unit panels. The unit panels may be held open with the door rod located inside the unit.

## A-Control Box Components

### ELECTROSTATIC DISCHARGE (ESD)

#### Precautions and Procedures



Control box components are shown in figures 1 and 2. The control box is located in the upper portion of the compressor compartment.

### 1-Disconnect Switch S48 (optional)

All units may be equipped with an optional disconnect switch

S48. Other factory or field installed optional circuit breakers may be used, such as CB10. S48 and CB10 are toggle or twist-style switches, which can be used by the service technician to disconnect power to the unit.

### 2-Terminal Strip TB2

When unit is not equipped with an optional S48 disconnect switch, supply power is connected to TB2.

### 3-Fuse F4

Fuse F4 is used only with single point power supply. F4 provides overcurrent protection to the compressor and other cooling components.

*Note - F4, S48 and TB2 are located inside a sheet metal enclosure in the unit left front corner mullion.*

### 4-Contactor Transformer T18

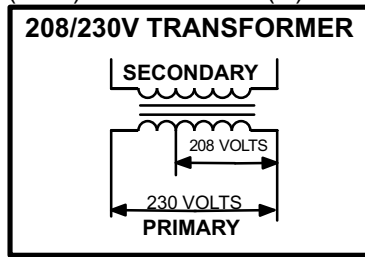
T18 is a single line voltage to 24VAC transformer used in all LCH 13 to 25 ton units. Transformer T18 is protected by a 3.5 amp circuit breaker (CB18). T18 is identical to transformer T1. The transformer supplies 24VAC power to the contactors.

### 5-Blower Contactor K3

Blower contactor K3, used in all units, is a three-pole double break contactor with a 24VAC coil used to energize the indoor blower motor B3 in response to blower demand. K3 is energized by the A55 Unit Controller.

## 6-Control Transformer T1

All use a single line voltage to 24VAC transformer mounted in the control box. Transformer supplies power to control circuits in the unit. The transformer is rated at 70VA and is protected by a 3.5 amp circuit breaker (CB8). The 208/230 (Y) voltage transformers use two



primary voltage taps as shown in figure 4, while 460 (G) and 575 (J) voltage transformers use a single primary voltage tap.

FIGURE 4

## 7-Terminal Block TB13

TB13 terminal block distributes line voltage power to the line voltage items in the unit.

## 8-Outdoor Fan Motor Fuse Block & Fuses F10 Power Exhaust Fan Motor Fuse Block and Fuses F6 (240 and 300 Y Volt Only)

Three line voltage fuses F10 provide overcurrent protection to all condenser fans. Two line voltage fuses F6 provide overcurrent protection to the two optional power exhaust fans. The fuses are rated at 30A in all 208/230V models but 10A in the 208/230V 240U and 300U model.

## 9-Outdoor Fan Capacitors C1, C2, C18, C19, C20, C21 (not used in 180U, 240U, 300U)

C1, C2, & C18: All units  
C19: 180, 210, 240, 300 Units  
C20 & C21: 210, 240, 300 Units

Fan capacitors C1, C2, C18, C19, C20 and C21 are 370V / 10 MFD capacitors used to assist in the start up of condenser fans B4, B5, B21, B22, B23 and B24 respectively.

## 10-Outdoor Fan Transformers T5, T59 (460V & 575V units)

All 460 (G) and 575 (J) voltage 180U, 240U and 300U units use transformer T5 and T59. The auto voltage to 230VAC transformers are mounted in the control box. The transformers have an output rating of 0.5A. T5 transformer supplies 230 VAC power to outdoor fans B4, B5 and B21. T13 transformer supplies 230V to outdoor fans B22, B23 and B24.

## 11-Compressor Contactor K1, K2, K14, K146

K1, K2, K14: All units  
K146: 180, 240, 300

All compressor contactors are three-pole-double-break contactors with 24VAC coils. K1 and K2 (energized by A55) energizes compressors B1 and B2 in response to first stage cool demand. K14 and K146 (energized by A59) en-

ergize compressors B13 and B20 in response to second stage cool demand. In 180U, 240U and 300U units, K14 and K146 is energized by A178 in response to second stage cool demand.

## 12-Outdoor Fan Relay K10, K68, K149, K150, K152, K153

K10 & K68: All units  
K149 & K150: 180, 210, 240, 300  
K152 & K153: 210, 240, 300

Outdoor fan relays are DPDT relays with a 24VAC coil.

In 156 units, K10 energizes fan 1 B4 and K68 energizes fan 2 B5 and fan 3 B21.

In 180 units, K10 energizes fan 1 B4, K68 energizes fan 2 B5, K149 energizes fan 3 B21 and K150 energizes fan 4 B22.

In 210, 240 and 300 units, K10 energizes fan 1 B4, K68 energizes fan 2 B5, K149 energizes fan 3 B21, K150 energizes fan 4 B22, K152 energizes fan 5 B23 and K153 energizes fan 6 B24..

## 13-Ultraviolet Germicidal Lamp (UVC) Transformer T49

UVC transformer T49 is used by units of all voltages except 208/230V and 575V which are equipped with a UVC. The auto voltage to 230VAC transformer is installed in the control box. The transformer has an output rating of 0.5 amps. T49 transformer supplies 230VAC power to the UVC lamp.

## 14-Power Exhaust Relay K65 (PED units)

Power exhaust relay K65 is a N.O. DPDT relay with a 24VAC coil. K65 is used in units equipped with the optional power exhaust dampers. K65 is energized by the A55 Unit Controller, after the economizer dampers reach 50% open (adjustable in ECTO). When K65 closes, the exhaust fans B10 and B11 are energized.

## 15-Unit Controller A55

The Unit Controller provides all unit control functions, unit status information, unit diagnostics, programmable parameters and USB verification and profile sharing. Refer to the Unit Controller guide provided with the unit. Thermostat wires are connected to J297 on the Unit Controller.

## 16-Compressor 3 & 4 Controller A59 (not used on (180U, 240U and 300U)

The compressor 3 & 4 control module A59 controls two additional compressor stages. A59 includes all inputs and outputs required for compressor and fan control, compressor stage diagnostics and low ambient control.

### 17-Variable Frequency Drive A96 (optional)

MSAV units are equipped with a VFD which alters the supply power frequency and voltage to the blower motor. Blower speed is staged depending on the compressor stages, heating demand, ventilation demand, or smoke alarm. The amount of airflow for each stage is preset from the factory. Airflow can be adjusted by changing ECTO parameters in the A55 Unit Controller. The VFD is located below the Unit Controller.

### 18-VFD Power To Motor Contactor K202 (optional)

Contactor is used in MSAV units equipped with a VFD bypass option. The three-pole 40 amp contactor with a 24VAC coil is energized by the A55 Unit Controller. K202 allows power from the VFD to the B3 blower motor in response to blower demand.

### 19-Inverter Start Forward Rotation Relay K203 (optional)

Relay is used in optional MSAV units and is a three-pole double-throw relay with a 24VAC coil. K203 is energized by the A55 Unit Controller and provides input to the A96 VFD to start blower forward rotation. K203 also de-energizes K3 allowing A96 to control B3 blower.

### 20-VFD Controller (GP board) A133 (MSAV units)

The GP board A133 controls and monitors the status of the VFD A96. The board sends the signal to start the VFD forward rotation and also sends a 0-10VDC signal to the VFD to control the speed of the blower rotation. A133 also reports VFD malfunctions to the A55.

### 21-Second-Stage Power Exhaust Relay K231 (MSAV units equipped with power exhaust)

The second power exhaust fan is controlled by K231. A133 will enable K231 only when the blower reaches 70% of full speed (adjustable ECTO). This prevents a negative building pressure when the blower is operating in low speed. Refer to the Unit Controller manual and ECTO labels on the unit.

### 22-Electric Heat Relay K9

All unit equipped with optional electric heat use an electric heat relay K9. K9 is a N.O. SPST pilot relay intended to electrically interlock operation of left and right side electric heat sections. K9 is energized by the A55 Unit Controller. K9-1 closes, energizing electric heat contactors K17 and K18.

### 23-Compressor 3 & 4 Controller A59 & A178

The compressor 3 & 4 control module A59 controls two additional compressor stages. A59 includes all inputs and outputs required for compressor and fan control, compressor stage diagnostics and low ambient control.

The M3 unit controller is only compatible with L-Connection sensors provided with the unit or purchased separately as specified in the Product Specification. Tables 1 through 4 show thermistor and pressure transducer readings.

### Temperature Sensors

The return air (RT16) and discharge air (RT6) duct probes and the outdoor air (RT17) are all two wire thermistors. The resistance vs. temperature table is shown below:

**TABLE 1  
Resistance vs. Temperature**

Temp. °F (°C)	Resistance +/-2%	Temperature °F (°C)	Resistance +/-2%	Temp. °F (°C)	Resistance +/-2%
-40 (-40)	335,671	40 (4.4)	26,106	90 (32.2)	7,332
-20 (-28.9)	164,959	50 (10)	19,904	100 (37.8)	5,826
0 (-17.8)	85,323	60 (15.6)	15,313	120 (48.9)	3,756
20 (-6.7)	46,218	70 (21.1)	11,884	130 (54.4)	3,047
30 (-1.1)	34,566	80 (26.7)	9,298		

**Room Sensors**

Room sensor (A2) is a two-wire thermistor with 1k series resistor.

**TABLE 2  
Two-Wire Thermistor**

Temp. °F (°C)	Resistance +/-2%	Temperature °F (°C)	Resistance +/-2%	Temp. °F (°C)	Resistance +/-2%
40 (4.4)	27,102	60 (15.6)	16,313	80 (26.7)	10,299
45 (7.2)	23,764	65 (18.3)	14,474	85 (29.4)	9,249
50 (10)	20,898	70 (21.1)	12,882	90 (32.2)	8,529
55 (12.8)	18,433	75 (23.9)	11,498		

**Carbon Dioxide Sensor**

The indoor carbon dioxide sensor (A63) is an analog sensor with a 0-10VDC output over a carbon dioxide range of 0-2000 ppm as shown in the following table. The sensor is powered with 24VAC.

**TABLE 3  
Carbon Dioxide Range**

Carbon Dioxide PPM	DC V	Carbon Dioxide PPM	DC Voltage	Carbon Dioxide PPM	DC Voltage	Carbon Dioxide PPM	DC V
0	0	600	3	1200	6	1800	9
200	1	800	4	1400	7	2000	10
400	2	1000	5	1600	8		

**VAV Supply Static Sensor**

The supply duct differential static pressure sensor (A30) is an analog sensor with a 0-10VDC output over a range of 0-5"w.c as shown in the following table. The sensor is powered with 24VAC.

**TABLE 4  
Static Pressure**

Pressure "w.c.	DC Voltage	Pressure "w.c.	DC Voltage	Pressure "w.c.	DC Voltage	Pressure "w.c.	DC Voltage
0	0	1.5	3	3	6	4.5	9
0.5	1	2	4	3.5	7	5	10
1	2	2.5	5	4	8		

**Relative Humidity Sensor - Optional**

The indoor relative humidity sensor (A91) is an analog sensor with a 0-10VDC output over a relative humidity range of 0-100% relative humidity. The sensor is powered with 24VAC.

**Enthalpy Sensor - Optional**

The optional enthalpy sensors (A7 and A63) used with the economizer have an output of 4-20mA. The sensor is powered with 18VAC provided by M3 unit control.

**Economizer Differential Pressure Sensor - Optional**

Rooftop units installed with Smart Airflow™ will have a Pressure Transducer (PT5) present in the economizer. PT5 requires 5VDC power supply (P266-5 and {P266-6) and gives 0.25 VDC to 4 VDC output (P266-4) corresponding to 0" water column and 2" water column respectively. For all practical purposes the output should be less than 1.2" water column if not an error code is stored and service alarm output is turned on.

## 24-Blower Motor Overload Relay S42

Two hp high efficiency blower motors and M-volt unit blower motors are equipped with an overload relay. High efficiency blower motors and M-volt unit blower motors manufactured before Dec. 19, 2010, are equipped with the relay. The relay (S42) is connected in line with the blower motor

to monitor the current flow to the motor. When the relay senses an overload condition, a set of normally closed contacts open to de-energize pin #1 in plug P299 of the A55 Unit Controller. A55 de-energizes all outputs. Units will be equipped with a relay manufactured by Telemecanique figure 5 or Siemens figure 6.

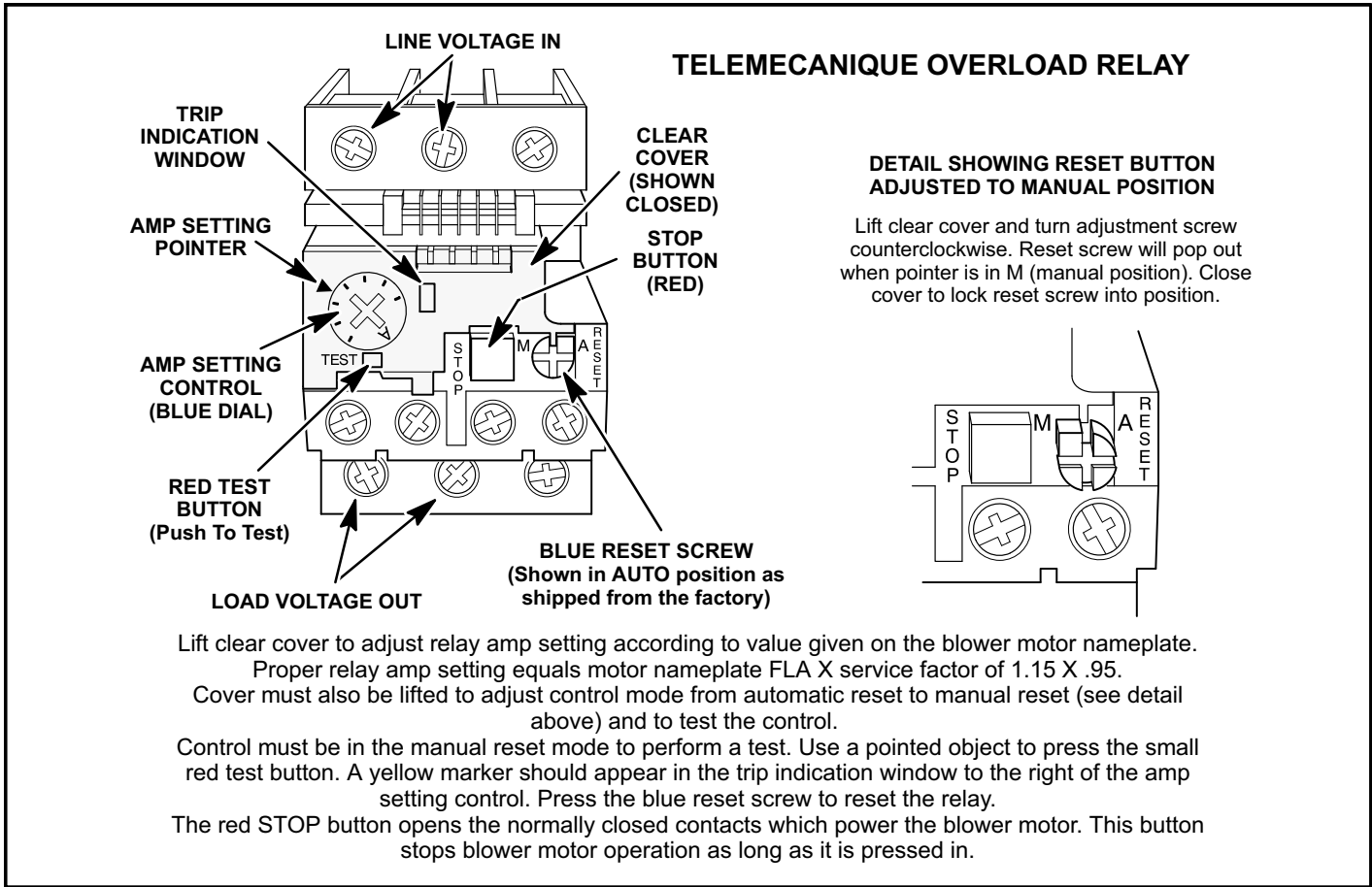


FIGURE 5

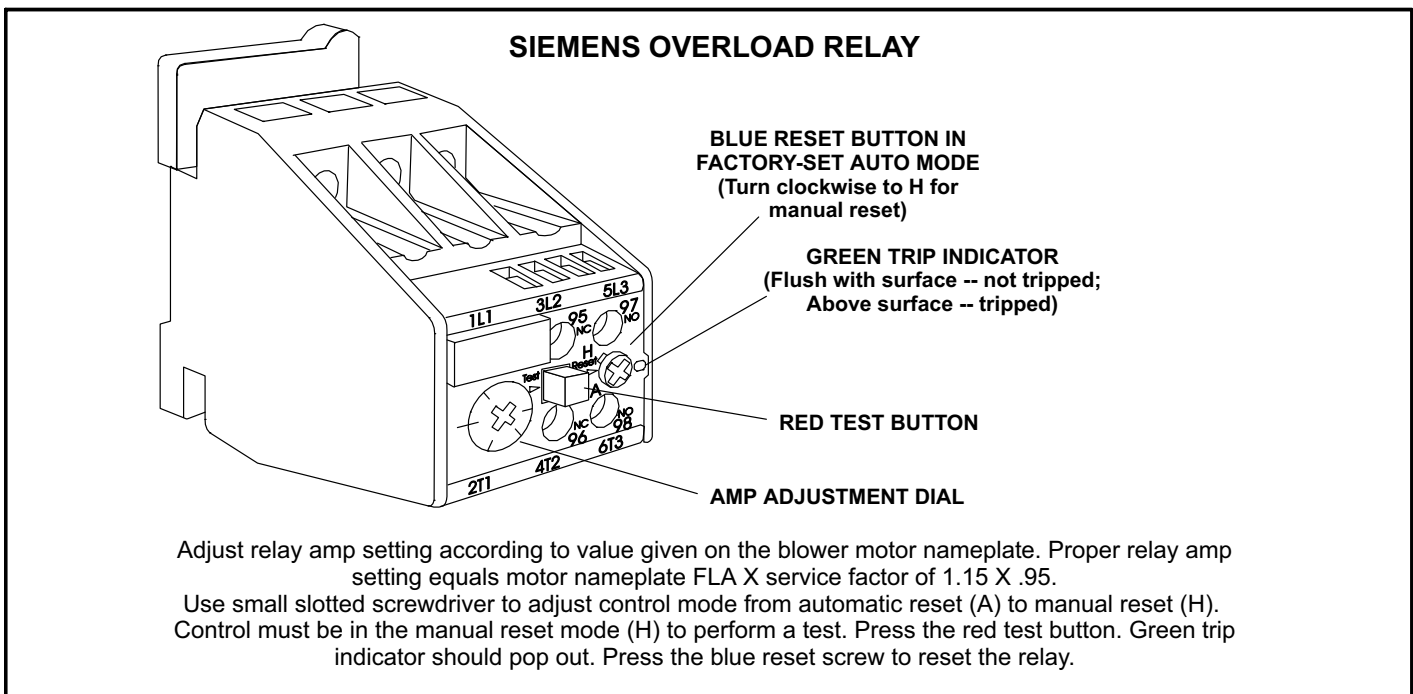


FIGURE 6



# 156H, 180H, 210H PLUMBING, COMPRESSOR AND REFRIGERANT CIRCUITS DETAIL

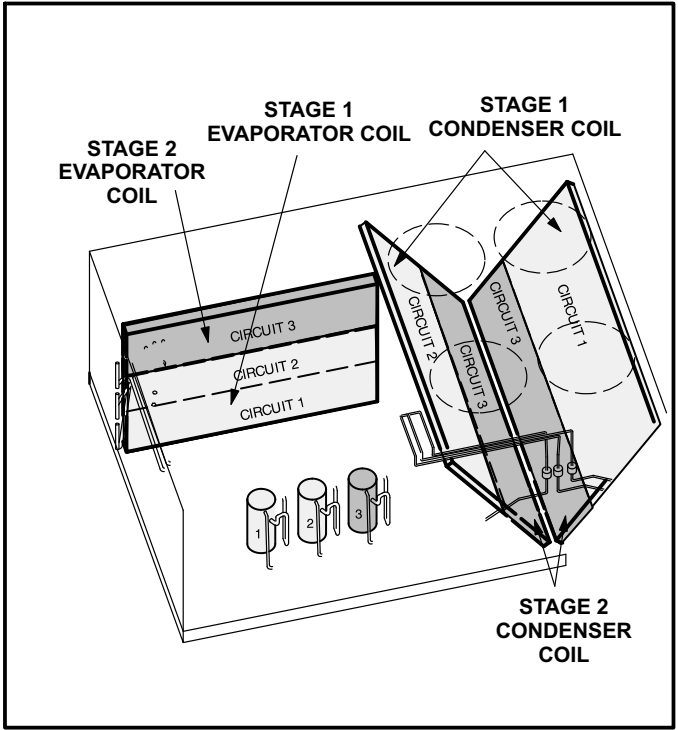
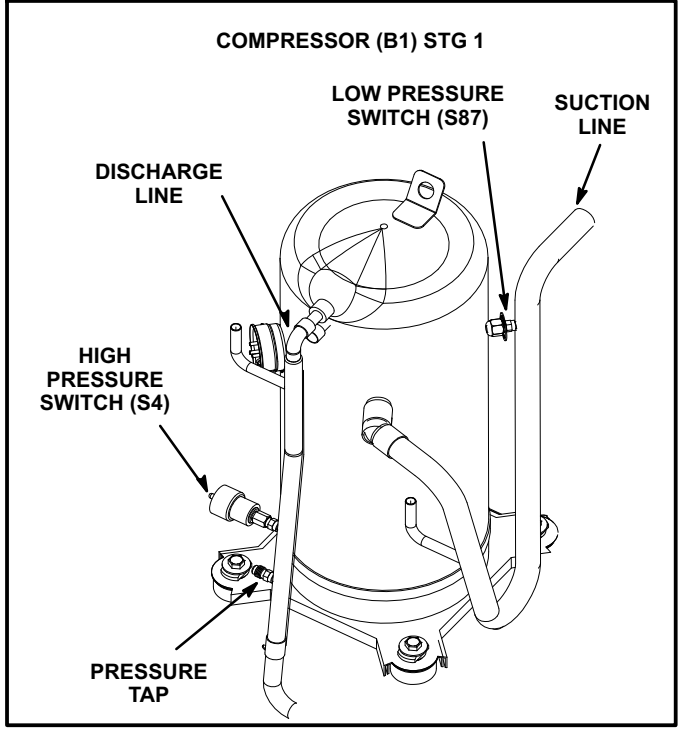
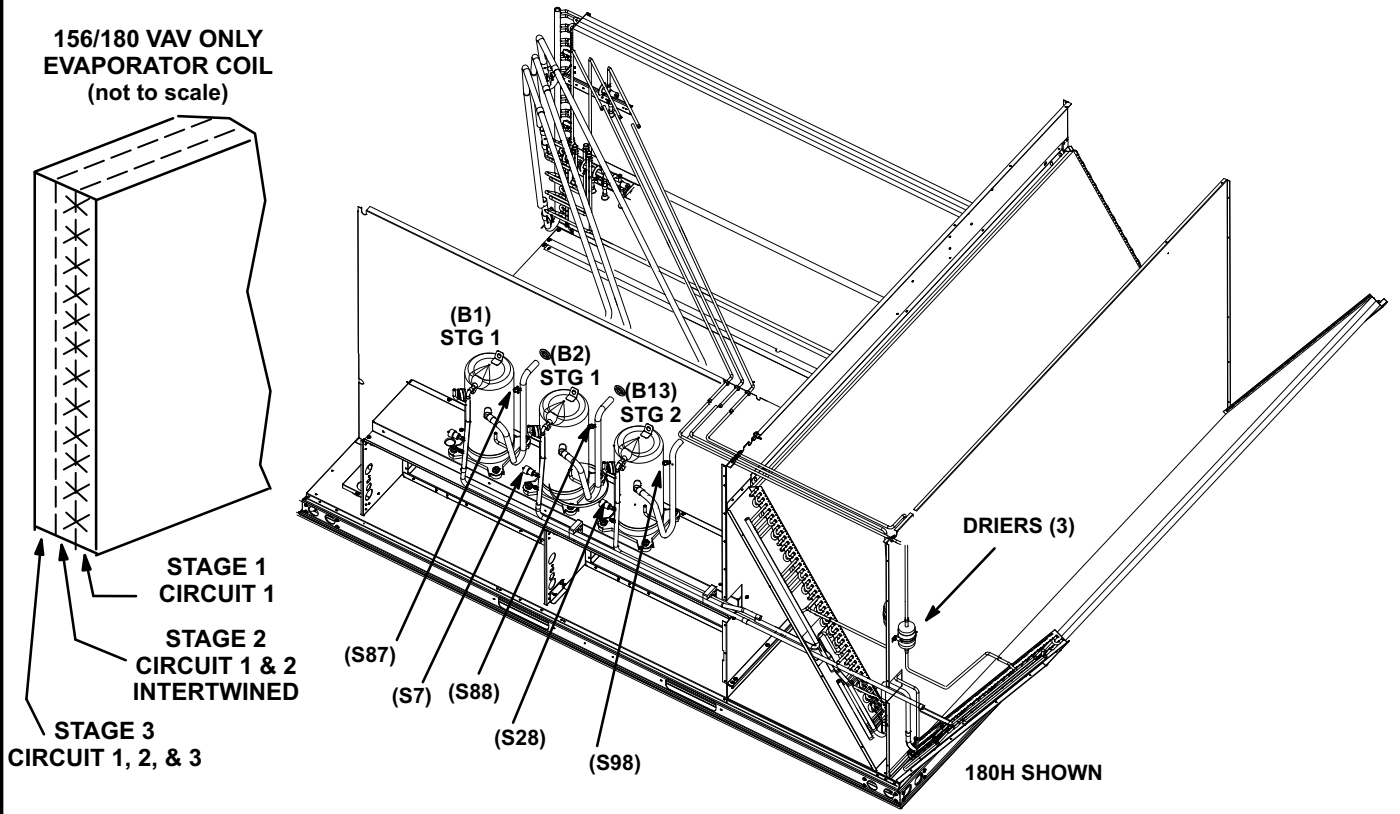
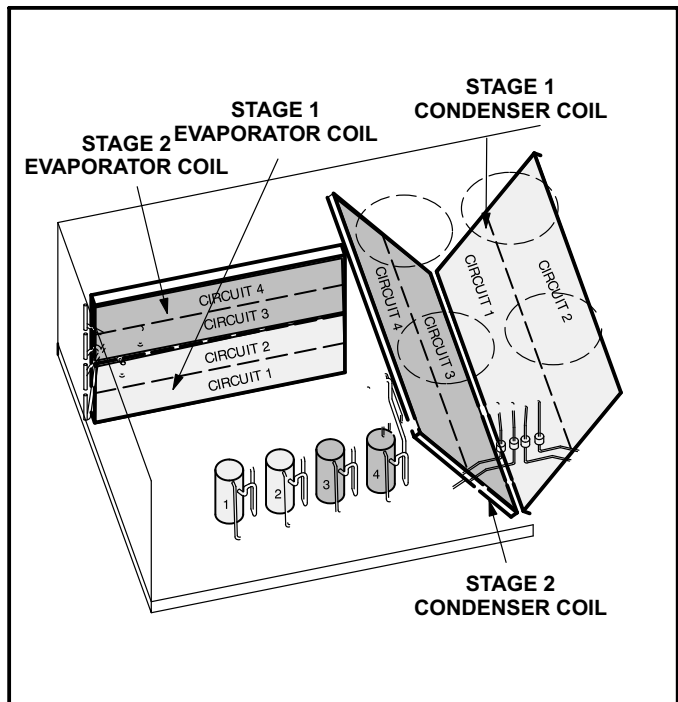
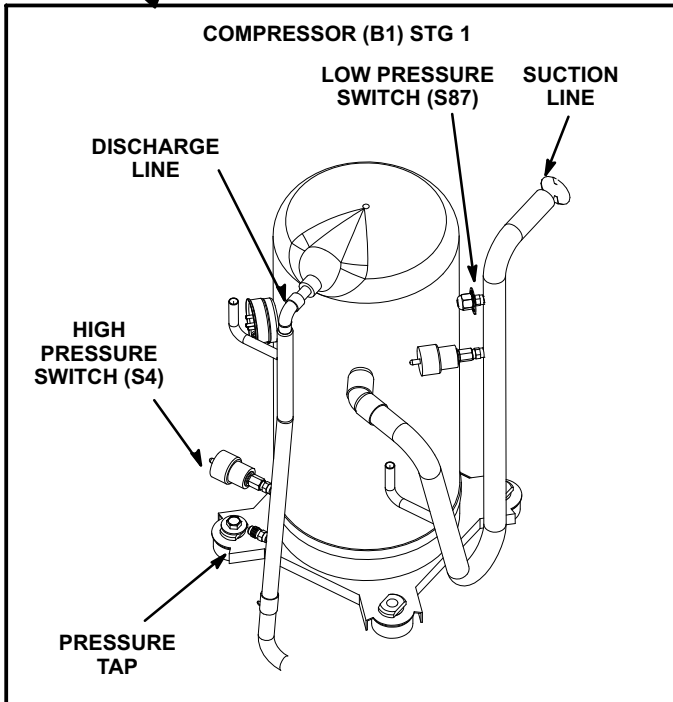
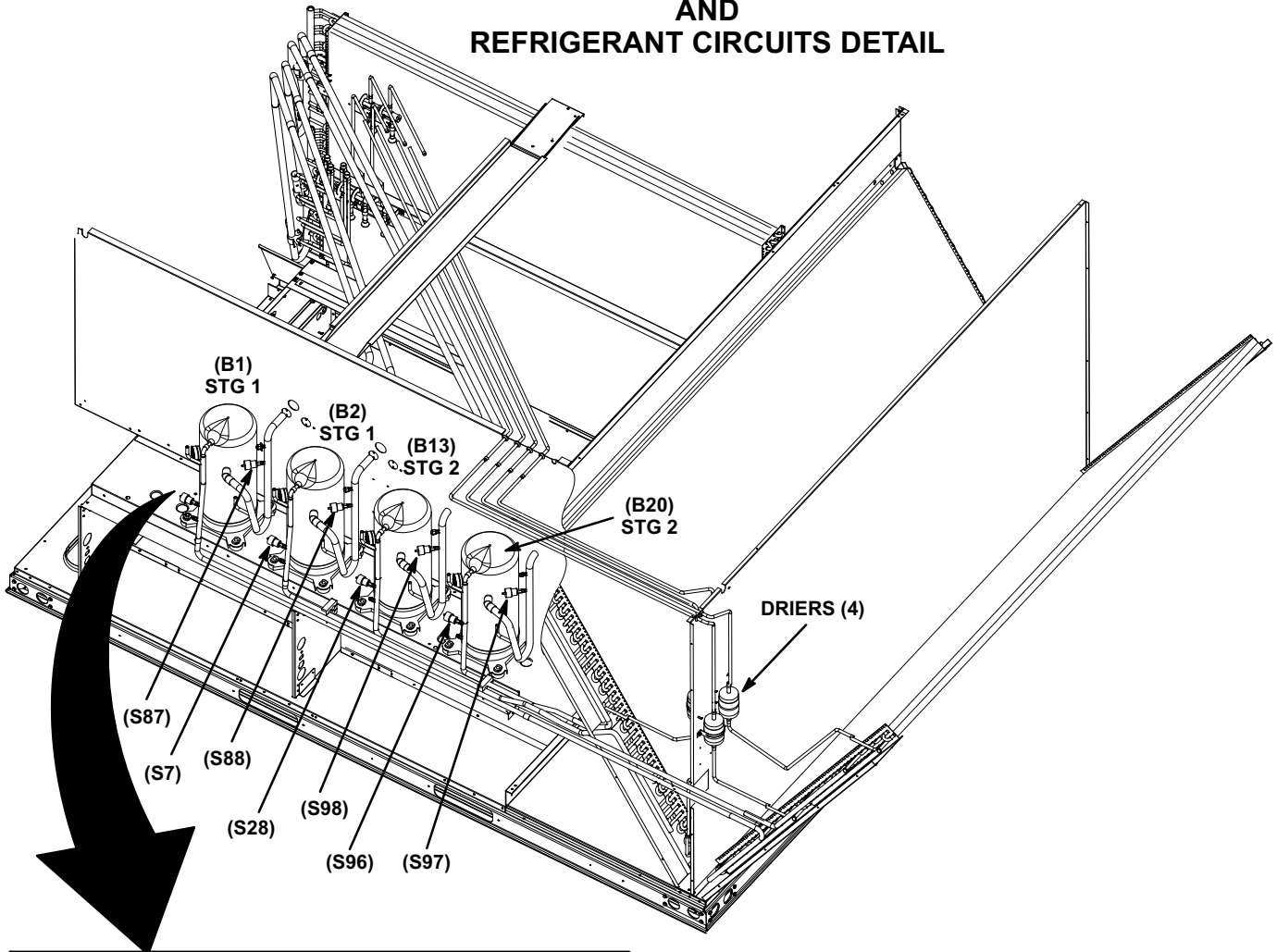


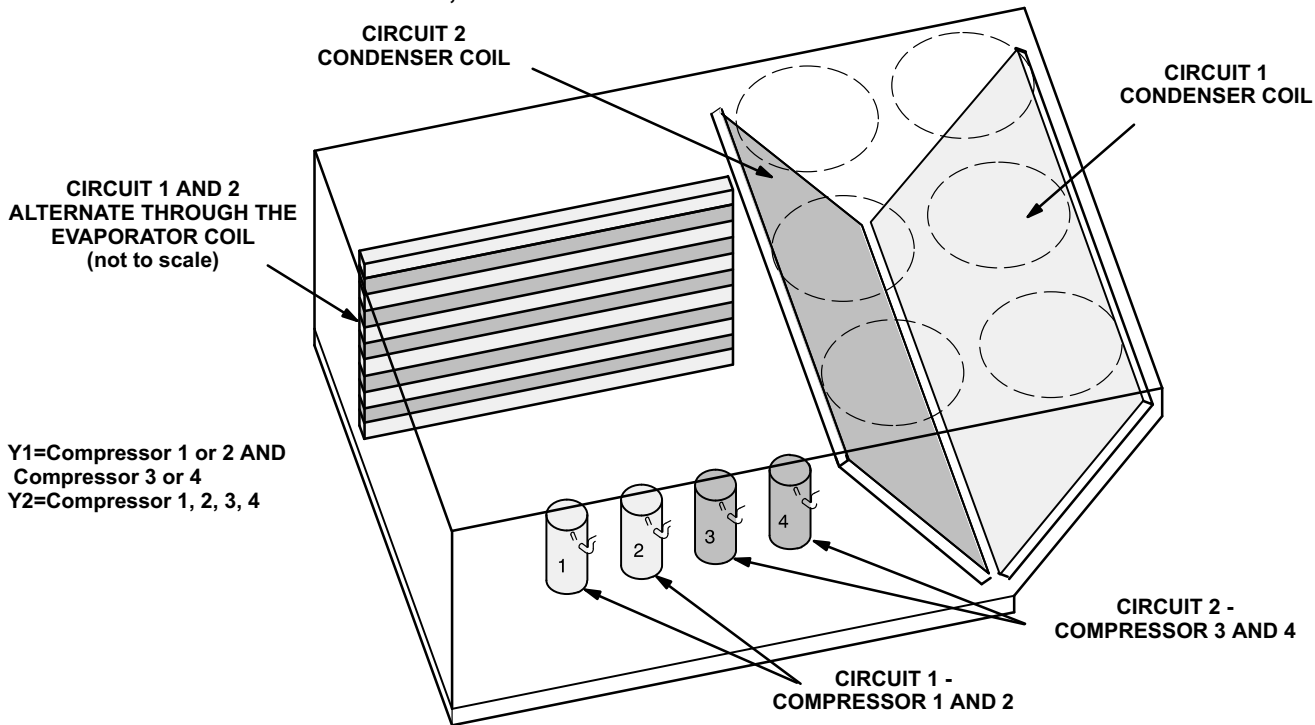
FIGURE 7

**240H, 300S, 300U PLUMBING, COMPRESSOR  
AND  
REFRIGERANT CIRCUITS DETAIL**

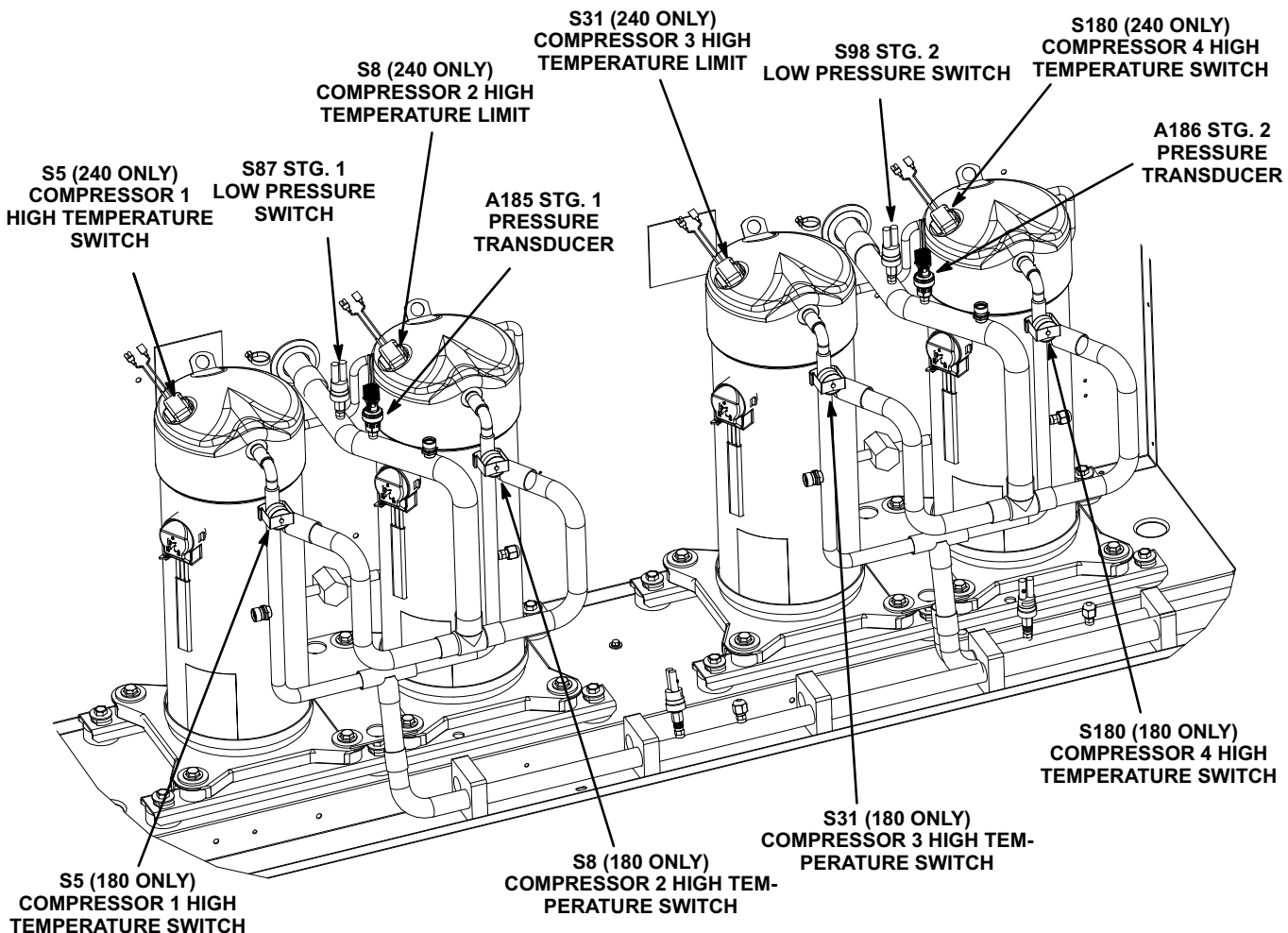


**FIGURE 8**

**180U, 240U & 300U REFRIGERANT CIRCUITS**



**180U, 240U & 300U COMPRESSOR DETAIL**



**FIGURE 9**

## B-Cooling Components

All units use independent cooling circuits consisting of separate compressors, condenser coils and evaporator coils. See figure 7 for 156H, 180H and 210H units, figure 8 for 240H and 300S units and figure 9 for 180U, 240U and 300U units.

Three draw-through type condenser fans are used in LCH156 units, four draw-through type condenser fans are used in LCH180 units and six draw-through type condenser fans are used in LCH210, 240 and 300 units. All units are equipped with belt-drive blowers which draw air across the evaporator during unit operation.

Cooling may be supplemented by a factory- or field-installed economizer. The evaporators are slab type and are stacked. Each evaporator uses a thermostatic expansion valve as the primary expansion device. Each evaporator is also equipped with enhanced fins and rifled tubing. In all units each compressor is protected by a crankcase heater, high pressure switch and low pressure switch. Additional protection is provided by low ambient switches and freezestats (on each evaporator).

### 1-Condenser Fans B4, B5, B21 (all units), B22 (180/300), B23, B24 (180U, 210/300)

See SPECIFICATIONS tables at the front of this manual for specifications of condenser fans used in all units. All condenser fans used have single-phase motors. The fan assembly may be removed for servicing and cleaning.

### 2-Compressors B1, B2, B13 (all units) B20 (180U, 240, 300)

All units use scroll compressors. LCH156, 180 and 210 use 3 compressors and LCH240 and 300 use four compressors and LCH180U, 240 and 300 use four compressors. All compressors are equipped with independent cooling circuits. Compressor capacity may vary from stage to stage. In all cases, the capacity of each compressor is added to reach the total capacity of the unit. See "SPECIFICATIONS" and "ELECTRICAL DATA" (table of contents) or compressor nameplate for compressor specifications.

## WARNING

**Electrical shock hazard. Compressor must be grounded. Do not operate without protective cover over terminals. Disconnect power before removing protective cover. Discharge capacitors before servicing unit. Failure to follow these precautions could cause electrical shock resulting in injury or death.**

Each compressor is energized by a corresponding compressor contactor.

*NOTE-Refer to the wiring diagram section for specific unit operation.*

If Interlink compressor replacement is necessary, call 1-800-453-6669.

## IMPORTANT

**Some scroll compressors have an internal vacuum protector that will unload scrolls when suction pressure goes below 20 psig. A hissing sound will be heard when the compressor is running unloaded. Protector will reset when low pressure in system rises above 40 psig. DO NOT REPLACE COMPRESSOR.**

### 3-Crankcase Heaters HR1, HR2, HR5 (all units) HR11 (240, 300)

All LCH units use insertion type heaters. Heater HR1 is installed around compressor B1, heater HR2 compressor B2, HR5 compressor B13 and HR11 compressor B20.

### 4-High Pressure Switches S4, S7, S28, S96

S4 all units  
S7 all standard and high efficiency units only  
S28 all units  
S96 240H and 300

The high pressure switches is an auto-reset SPST N.C. switch which opens on a pressure rise. All units are equipped with this switch. The switch is located in the compressor discharge line and is wired in series with the compressor contactor coil through A55 Unit Controller or A59 Compressor 3 and 4 Controller.

S4 (first circuit), S7 (second circuit), S28 (third circuit) and S96 (fourth circuit) are wired in series with the respective compressor contactor coils.

When discharge pressure rises to  $640 \pm 10$  psig ( $4413 \pm 69$  kPa) (indicating a problem in the system) the switch opens and the respective compressor is de-energized (the economizer can continue to operate). When discharge pressure drops to  $475 \pm 20$  psig ( $3275 \pm 138$  kPa) the pressure switch will close.

Main control A55 has a three-strike counter before locking out. This means the control allows three high pressure trips per one thermostat demand. The control can be reset by breaking and remaking the thermostat demand or manually resetting the control.

### 5-Low Ambient Switches S11, S84, S85, S94

S11 all units  
S84 all standard and high efficiency units only  
S85 all units  
S94 240H and 300

The low ambient switch is an auto-reset SPST N.O. pressure switch which allows for mechanical cooling operation at low outdoor temperatures. All units are equipped with this switch. In all models a switch is located in each liquid line prior to the indoor coil section.

In LCH156/210 units, S11 (compressor one) is wired to the Unit Controller (A55) and S84 (compressor two) and S85 (compressor three) are wired in parallel to the Unit Controller. In LCH240/300 units, S11 (compressor one) and S84 (compressor 2) are wired in parallel to the Unit Controller; S85 (compressor 3) and S94 (compressor four) are wired in parallel to the Unit Controller.

When liquid pressure rises to  $450 \pm 10$  psig ( $3102 \pm 69$  kPa), the switch closes. When liquid pressure drops to  $240 \pm 10$  psig ( $1655 \pm 69$  kPa), the switch opens and the Unit Controller will cycle condenser fans via the following outdoor fan relays:

- K10 and K68 (156H, 180H, 210H, 300)
- K149 and K150 (180H, 210, 240H, 300 units)
- K152 and K153 (180U, 210, 240, 300 units)

The Unit Controller cycles fans based on the low ambient pressure switch inputs and outdoor ambient temperature.

This intermittent fan operation results in higher evaporating temperature allowing the system to operate without icing the evaporator coil and losing capacity.

## 6-Low Pressure Switches S87, S88, S97, S98

- S87 all units
- S88 all standard and high efficiency units only
- S97 240H, 300
- S98 all units

The low pressure switch is an auto-reset SPST N.O. switch (held N.C. by refrigerant pressure) which opens on a pressure drop. All units are equipped with this switch. The switch is located in the compressor suction line.

S87 (compressor one), S88 (compressor two), S98 (compressor three) and S97 (compressor four) are wired in series with the contactor coils through the A55 Unit Controller.

The Unit Controller A55 governs the low pressure switches by shunting the switches during start up until pressure is stabilized. After the shunt period, the control has a three-strike counter, during first thermostat demand, before the compressor is locked out. The control is reset by breaking and remaking the thermostat demand or manually resetting the control.

When suction pressure drops to  $40 \pm 5$  psig ( $276 \pm 34$  kPa), (indicating low pressure), the switch opens and the compressor is de-energized. The switch automatically resets when pressure in the suction line rises to  $90 \pm 5$  psig ( $620 \pm 34$  kPa) due to many causes such as refrigerant being added.

## 7-Filter Drier (all units)

Units have a filter drier located in the liquid line of each refrigerant circuit at the exit of each condenser coil. The drier removes contaminants and moisture from the system.

## 8-Freezestats S49, S50, S53, S95

- S49 all units
- S50 all standard and high efficiency units only
- S53 180U, 240U, 300U
- S95 240H, 300

Each unit is equipped with a low temperature switch (freezestat) located on the return bend of each evaporator coil. S49 (first circuit), S50 (second circuit), S53 (third circuit) and S95 (fourth circuit) are located on the corresponding evaporator coils.

Each freezestat is wired in series with the compressor contactor coil through the unit control box to the A55 Unit Controller. Each freezestat is a SPST N.C. auto-reset switch which opens at  $29^{\circ}\text{F} \pm 3^{\circ}\text{F}$  ( $-1.7^{\circ}\text{C} \pm 1.7^{\circ}\text{C}$ ) on a temperature drop and closes at  $58^{\circ}\text{F} \pm 4^{\circ}\text{F}$  ( $14.4^{\circ}\text{C} \pm 2.2^{\circ}\text{C}$ ) on a temperature rise. To prevent coil icing, freezestats open during compressor operation to temporarily disable the respective compressor until the coil warms sufficiently to melt any accumulated frost.

If the freezestats are tripping frequently due to coil icing, check the unit charge, airflow and filters before allowing unit back in operation. Make sure to eliminate conditions which might promote evaporator ice buildup.

## 9-Service Valve (optional)

Units may be equipped with service valves located in the discharge and liquid lines. The service valves are manually operated valves used for service operation.

## 10-Pressure Transducer A185 &A186 (180U, 240U & 300U)

Ultra high efficiency units are equipped with a pressure transducer located on the common suction line. The Unit Controller uses the input from the transducer A185, sensors RT37 and RT38 (stage one) and transducer A186 sensor RT39 and RT40 (second stage) to calculate sump superheat for each compressor. The Unit Controller uses this information to optimize system reliability.

Verify the sensor value using the menu path:

MAIN MENU > DATA > IN/OUTPUTS > SENSORS > LOCAL  
A185 and A186 should read within +/- 10 psi of actual suction pressure.

## 11-High Temperature Limit Switch S5, S8, S31 &S180 (180U, 240U & 300U)

These high temperature limit switches are N.C and wired in series with the compressor contactors. When opened due to high temperature the compressor contactors are de-energized, de-energizing the compressors. S5 and S8 are in series with contactors K1 and K2 and compressors B1 and B2. S31 and S180 are in series with contactors K14 and K146 and compressors B13 and B20. See unit diagram.

## C-Blower Compartment

The blower compartment is located between the evaporator coil and the compressor / control section on the opposite side of the condenser coil. The blower assembly is accessed by disconnecting the blower motor wiring (and all other plugs) and removing the screws on either side of the sliding base. The base pulls out as shown in figure 10.

### 1-Blower Wheels

All units have two 15 in. x 15 in. (381 mm x 381 mm) blower wheels. Both wheels are driven by one motor.

### 2-Indoor Blower Motor B3

All units use three-phase single-speed blower motors. CFM adjustments are made by adjusting the motor pulley (sheave). Motors are equipped with sealed ball bearings. All motor specifications are listed in the SPECIFICATIONS (table of contents) in the front of this manual. Units may be equipped with motors manufactured by various manufacturers, therefore electrical FLA and LRA specifications will vary. See unit rating plate for information specific to your unit.

## OPERATION / ADJUSTMENT

**MSAV® Units** - The blower rotation will always be correct on MSAV™ units. Checking blower rotation is not a valid method of determining voltage phasing for incoming power.

**MSAV® Units and Units Equipped With Optional Voltage or Phase Detection** - The Unit Controller checks the incoming power during start-up. If the voltage or phase is incorrect, the Unit Controller will display an alarm and the unit will not start.

### Blower Operation

*NOTE-The following is a generalized procedure and does not apply to all thermostat control systems.*

- 1- Blower operation is dependent on the thermostat control system option that has been installed in the units. Refer to operation sequence of the control system installed for detailed descriptions of blower operation.
- 2- Generally, blower operation is set at the thermostat fan switch. With the fan switch in "ON" position and the **OCP** input is "**ON**", the blower operates continuously. With the fan switch in "AUTO" position, the blower cycles with demand.
- 3- In most cases, the blower and entire unit will be off when the system switch is in the "OFF" position. The only exception is immediately after a heating demand when the blower control keeps the blower on until all heat is extracted from the heat exchanger.

## ⚠ IMPORTANT

### Three Phase Scroll Compressor Voltage Phasing

**Three phase scroll compressors must be phased sequentially to ensure correct compressor and blower\* rotation and operation. Compressor and blower are wired in phase at the factory. Power wires are color-coded as follows: line 1-red, line 2-yellow, line 3-blue.**

**1-Observe suction and discharge pressures and blower\* rotation on unit start-up.**

**2-Suction pressure must drop, discharge pressure must rise and blower\* rotation must match rotation marking.**

**If pressure differential is not observed or blower\* rotation is not correct:**

**3-Disconnect all remote electrical power supplies.**

**4-Reverse any two field-installed wires connected to the line side of S48 disconnect or TB13 terminal strip. Do not reverse wires at blower contactor.**

**5-Make sure the connections are tight.**

**Discharge and suction pressures should operate at their normal start-up ranges.**

**\*Supply air VFD motors should rotate in the correct direction; verify scroll compressor rotation separately. Contact technical support if the VFD blower is rotating incorrectly.**

### Determining Unit Air Volume

*IMPORTANT - MSAV® units are factory-set to run the blower at full speed when there is a blower (G) demand without a heating or cooling demand. Refer to the field-provided, design specified CFM for all modes of operation. Use the following procedure to adjust motor pulley to deliver the highest CFM called for in the design spec. See MSAV® Start-Up section to set blower CFM for all modes once the motor pulley is set.*

On VAV units duct static feedback will control indoor blower CFM for beltline with a VFD.

### Variable Air Volume Units - Refer to the Variable Air Volume Start-Up section.

- 1 The following measurements must be made with a dry indoor coil. Run blower (G demand) without a cooling demand. Measure the indoor blower shaft RPM. Air filters must be in place when measurements are taken.
- 2 With all access panels in place, measure static pressure external to unit (from supply to return). Blower performance data is based on static pressure readings taken in locations shown in figure 11.

*Note - Static pressure readings can vary if not taken where shown.*

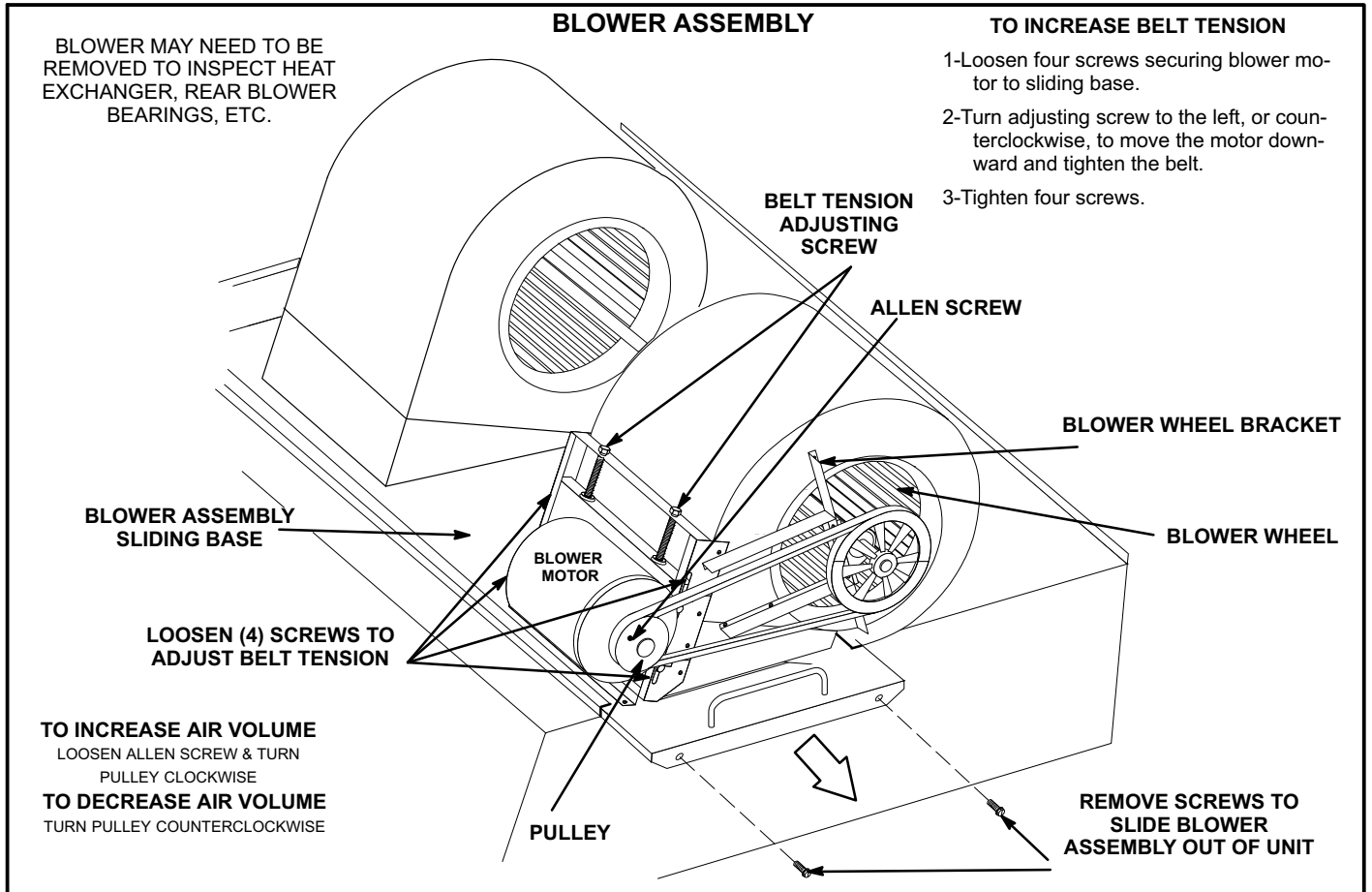
- 3 Referring to page 17, use static pressure and RPM readings to determine unit CFM. Use page 18 when installing units with any of the optional accessories listed.

4 The blower RPM can be adjusted at the motor pulley. Loosen Allen screw and turn adjustable pulley clockwise to increase CFM. Turn counterclockwise to decrease CFM. See figure 10. Do not exceed minimum and maximum number of pulley turns as shown in table 5.

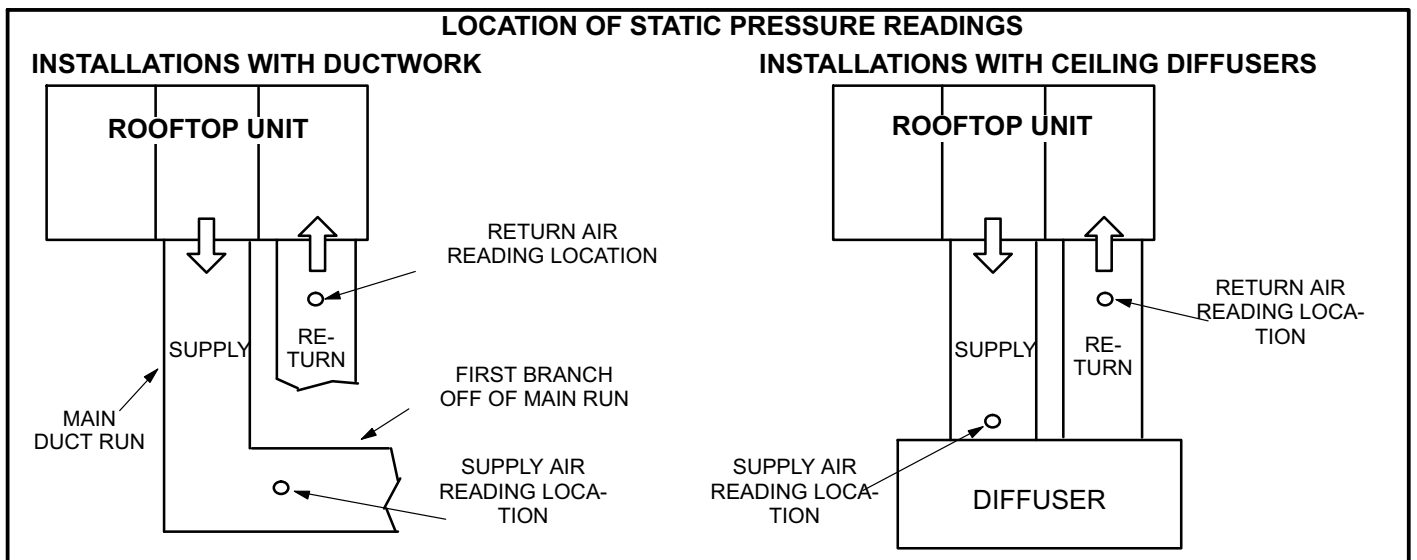
**TABLE 5  
MINIMUM AND MAXIMUM PULLEY ADJUSTMENT**

Belt	Minimum Turns Open	Maximum Turns Open
A Section	No minimum	5
B Section	1*	6

\*No minimum number of turns open when B belt is used on pulleys 6" O.D. or larger.



**FIGURE 10**



**FIGURE 11**

### Determining Unit Air Volume

- 1- The following measurements must be made with a dry indoor coil. Run blower without cooling demand. Air filters must be in place when measurements are taken.
- 2- With all access panels in place, measure static pressure external to unit (from supply to return).
- 3- Measure the indoor blower wheel RPM.
- 4- Refer to blower tables in BLOWER DATA (table of contents) in the front of this manual. Use static pressure and RPM readings to determine unit air volume.
- 5- The RPM can be adjusted at the motor pulley. Loosen Allen screw and turn adjustable pulley clockwise to increase RPM. Turn counterclockwise to decrease RPM. See figure 10.

### Blower Belt Adjustment

Maximum life and wear can be obtained from belts only if proper pulley alignment and belt tension are maintained. Tension new belts after a 24-48 hour period of operation. This will allow belt to stretch and seat into pulley grooves. Make sure blower and motor pulley are aligned as shown in figure 12 for standard blowers and figure 13 for units equipped with an optional belt tensioner.

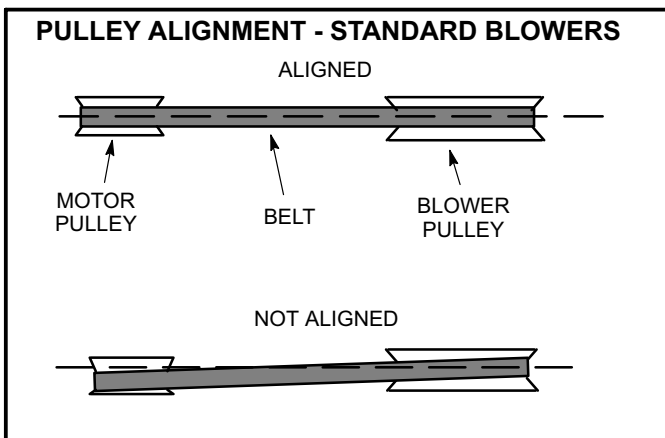


FIGURE 12

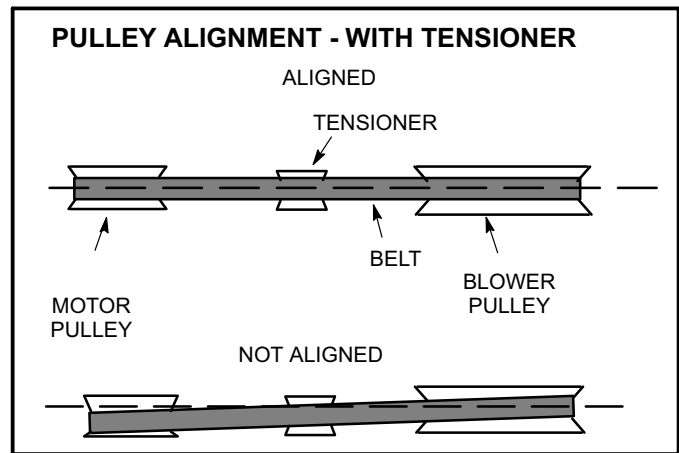


FIGURE 13

### Standard Blowers

- 1 Loosen four screws securing blower motor to sliding base. See figure 10.
- 2 *To increase belt tension -*  
Turn belt tension adjusting screw to the left, or counterclockwise, to tighten the belt. This increases the distance between the blower motor and the blower housing.  
*To loosen belt tension -*  
Turn the adjusting screw to the right, or clockwise to loosen belt tension.
- 3 Tighten four screws securing blower motor to sliding base once adjustments have been made.

### Blowers Equipped With Belt Tensioner

- 1 Loosen the bolt in the center of the tensioner. See figure 14.
- 2 Place belt over all three pulleys.
- 3 Using a 15/16" wrench, turn the tensioner nut until marks align as shown in figure 14.
- 4 Hold the tensioner with marks aligned and tighten the bolt to 22 ft.lbs. using the 9/16" wrench.



## PULLEY ALIGNMENT - WITH TENSIONER

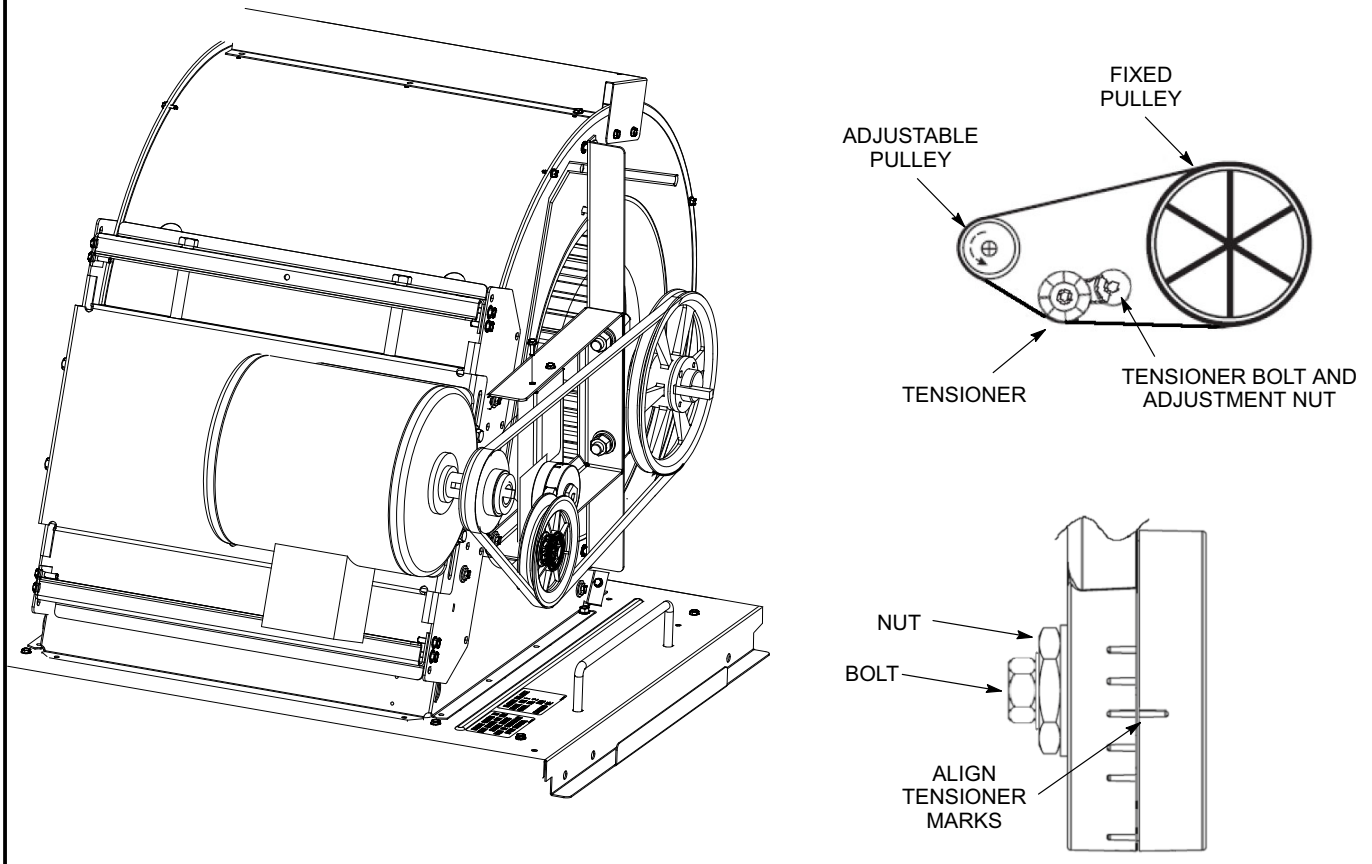


FIGURE 14

### Check Belt Tension

Overtensioning belts shortens belt and bearing life. Check belt tension as follows:

- 1 Measure span length X. See figure 15.
- 2 Apply perpendicular force to center of span (X) with enough pressure to deflect belt  $1/64$ " for every inch of span length or 1.5mm per 100mm of span length.

Example: Deflection distance of a 40" span would be  $40/64$ " or  $5/8$ ".

Example: Deflection distance of a 400mm span would be 6mm.

- 3 Measure belt deflection force. For a used belt, the deflection force should be 5 lbs. (35kPa) . A new belt deflection force should be 7 lbs. (48kPa).

A force below these values indicates an undertensioned belt. A force above these values indicates an overtensioned belt.

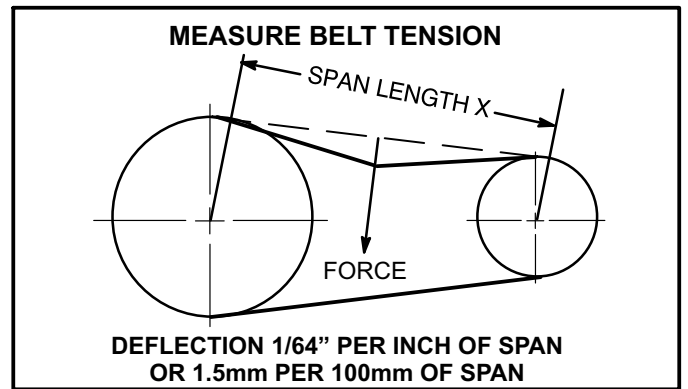


FIGURE 15

### Field-Furnished Blower Drives

For field-furnished blower drives, Refer to blower tables in BLOWER DATA section to determine BHP and RPM required. Reference table 6 and 7 to determine the manufacturer's model number.

**TABLE 6**

Drive No.	H.P.	DRIVE COMPONENTS					
		RPM		ADJUSTABLE SHEAVE		FIXED SHEAVE	
		Min	Max	Supplier No.	OEM Part No.	Supplier No.	OEM Part No.
1	2 & 3 Std.	535	725	1VP40x7/8	79J0301	BK95 x 1-7/16	80K1601
2	2 & 3 Std.	710	965	1VP40x7/8	79J0301	BK72 x 1-7/16	100244-13
3	3 High & 5	685	865	1VP50x1-1/8	P-8-1977	BK100 x 1-7/16	39L1301
4	3 High & 5	850	1045	1VP65x1-1/8	100239-03	BK110H	100788-06
5	5	945	1185	1VP60x1-1/8	41C1301	BK90H x 1-7/16	100788-04
6	7.5	850	1045	1VP65x1-3/8	78M7101	BK110H	100788-06
7	7.5 & 10	945	1185	1VP60x1-3/8	78L5501	BK90H x 1-7/16	100788-04
8	7.5	1045	1285	1VP65x1-3/8	78M7101	BK90H x 1-7/16	100788-04
10	10	1045	1285	1VP65x1-3/8	78M7101	1B5V86	78M8301
11	10	1135	1365	1VP65x1-3/8	78M7101	1B5V80	100240-05

**TABLE 7**

Drive No.	H.P.	DRIVE COMPONENTS							
		RPM		BELTS (STD.)		BELTS (WITH TENSIONER)		SPLIT BUSHING	
		Min	Max	Supplier No.	OEM Part No.	Supplier No.	OEM Part No.	Supplier No.	OEM Part No.
1	2 & 3 Std.	535	725	BX59	59A5001	BX60	100245-10	N/A	N/A
2	2 & 3 Std.	710	965	BX55	63K0501	BX56	100245-11	N/A	N/A
3	3 High & 5	685	865	BX61	93J9801	BX62	57A7701	N/A	N/A
4	3 High & 5	850	1045	BX66	97J5901	BX67	100245-09	H-1-7/16	49M6201
5	5	945	1185	BX61	93J9801	BX62	57A7701	H-1-7/16	49M6201
6	7.5	850	1045	BX66	97J5901	BX67	100245-09	H-1-7/16	49M6201
7	7.5 & 10	945	1185	BX63	97J5501	BX64	97J5801	H-1-7/16	49M6201
8	7.5	1045	1285	BX64	97J5801	BX65	100245-08	H-1-7/16	49M6201
10	10	1045	1285	5VX670	100245-21	5VX680	100245-35	B-1-7/16	100246-01
11	10	1135	1365	5VX660	100245-20	5VX670	100245-21	B-1-7/16	100246-01

## D-Optional Electric Heat Components

See ELECTRICAL / ELECTRIC HEAT DATA and ELECTRIC HEAT CAPACITIES (table of contents) for LCH to EHA match-ups and electrical ratings.

EHA parts arrangement is shown in figures 17 and 18. All electric heat sections consist of electric heating elements exposed directly to the air stream. Two electric heat sections (first section and second section) are used in all 15kW through 90kW heaters. See figure 16. Multiple-stage elements are sequenced on and off in response to thermostat demand.

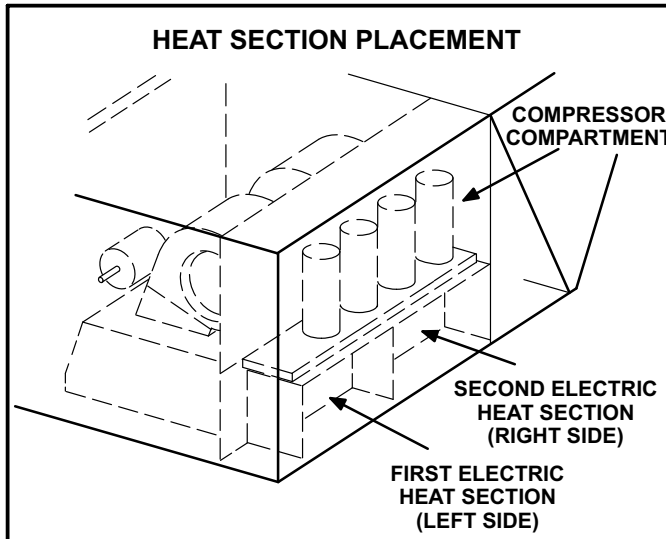


FIGURE 16

### 1-Main Control Box Components A55, K9

The main control box (see figure 1) houses the A55 Unit Controller and the K9 electric heat relay. For a description of the components see section I-A.

### 2-Contactors K15, K16, K17 and K18

Contactors K15, K16, K17 and K18 are all three-pole double-break contactors located on the electric heat vestibule. K15 and K16 are located on the first electric heat section, while K17 and K18 are located on the second electric heat section. However, in the 15 and 30kW heaters, the first section houses all contactors and fuses. All contactors are equipped with a 24VAC coil. The coils in the K15, K16, K17 and K18 contactors are energized by the main panel A55. Contactors K15 and K17 energize the first stage heating elements, while K16 and K18 energize the second stage heating elements.

### 3-High Temperature Limits S15 and S107 (Primary)

S15 and S107 are SPST N.C. auto-reset thermostats located on the back panel of the electric heat section below the heating elements. S15 is the high temperature limit for the first electric heat section, while S107 is the high temperature limit for the second electric heat section. Both thermostats are identical and are wired to the A55 Unit Controller. When either S15 or S107 opens, indicating a problem in the system, contactor K15 is de-energized. When K15 is de-energized, first stage and all subsequent stages of heat are de-energized. The thermostats used on EHA360-45-1 Y/G/J are factory set to open at  $200^{\circ}\text{F} \pm 5^{\circ}\text{F}$  ( $93.3^{\circ}\text{C} \pm 2.8^{\circ}\text{C}$ ) on a temperature rise and automatically reset at  $160^{\circ}\text{F} \pm 6^{\circ}\text{F}$  ( $71.1^{\circ}\text{C} \pm 3.3^{\circ}\text{C}$ ) on a temperature fall. All other electric heat section thermostats are factory set to open at  $170^{\circ}\text{F} \pm 5^{\circ}\text{F}$  ( $76.7^{\circ}\text{C} \pm 2.8^{\circ}\text{C}$ ) on a temperature rise and automatically reset at  $130^{\circ}\text{F} \pm 6^{\circ}\text{F}$  ( $54.4^{\circ}\text{C} \pm 3.3^{\circ}\text{C}$ ) on a temperature fall. The thermostats are not adjustable.

### 4-Terminal Strip TB3

Electric heat line voltage connections are made to terminal strip TB3 (or a fuse block on some models) located in the upper left corner of the electric heat vestibule.

### 5-Heating Elements HE1 through HE14

Heating elements are composed of helix wound bare nichrome wire exposed directly to the air stream. Three elements are connected in a three-phase arrangement. The elements in 208/230V units are connected in a "Delta" arrangement. Elements in 460 and 575V units are connected in "Wye" arrangement. Each stage is energized independently by the corresponding contactors located on the electric heat vestibule panel. Once energized, heat transfer is instantaneous. High temperature protection is provided by primary and redundant high temperature limits and overcurrent protection is provided by fuses.

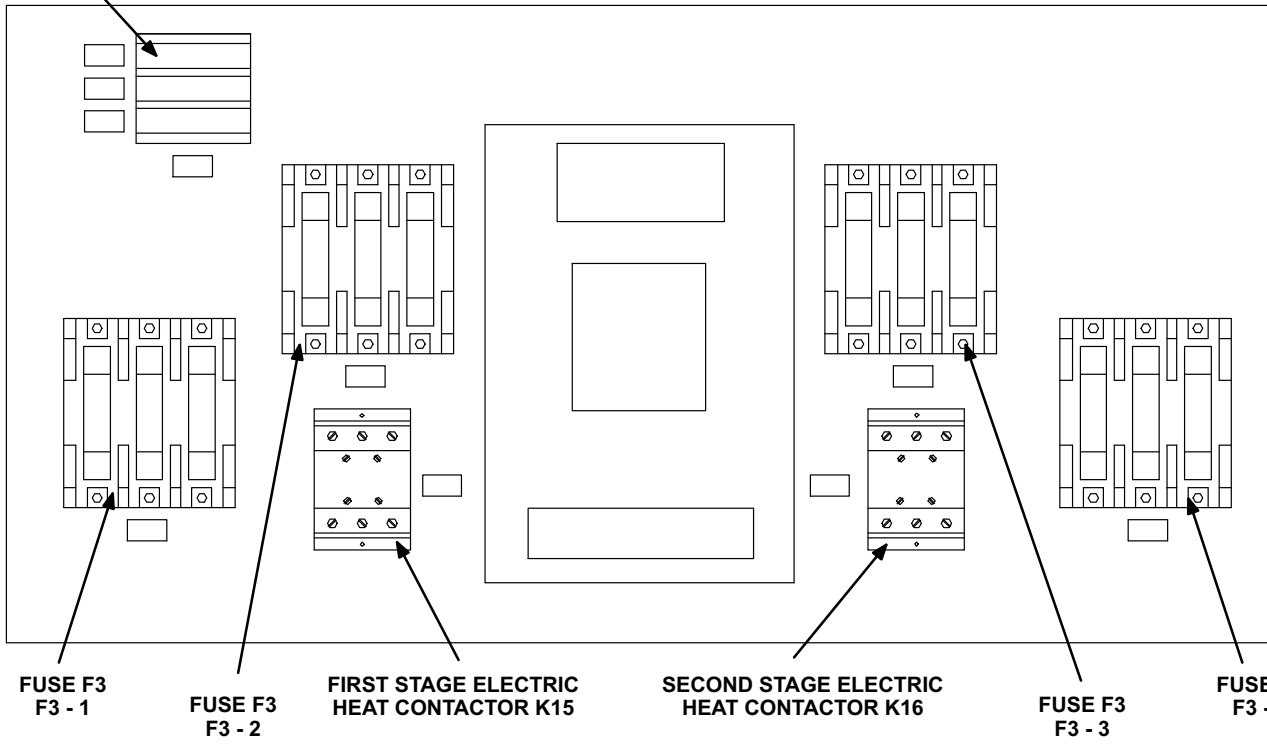
### 6-Fuse F3

Fuse F3 are housed in a fuse block which holds three fuses. Each F3 fuse is connected in series with each leg of electric heat. Figures 17 and 18 and table 8 shows the fuses used with each electric heat section. For simplicity, the service manual labels the fuses F3 - 1 through F3 - 8.

# ELECTRIC HEAT VESTIBULE PARTS ARRANGEMENT

TERMINAL STRIP (TB3)

## FIRST HEAT SECTION (LEFT SIDE)



TERMINAL STRIP (TB3)

## SECOND HEAT SECTION (RIGHT SIDE)

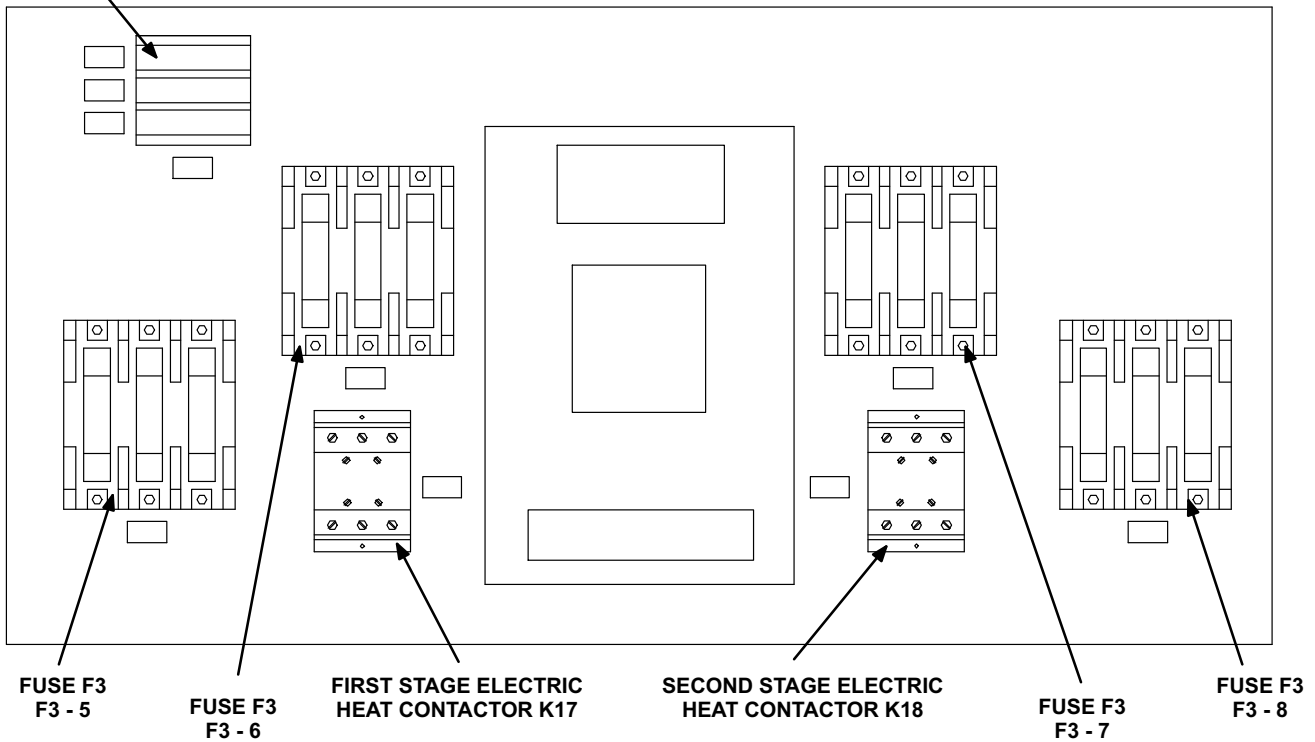


FIGURE 17

## EHA 15, 30, 45, 60 and 90 KW ELECTRIC HEAT SECTION PARTS ARRANGEMENT

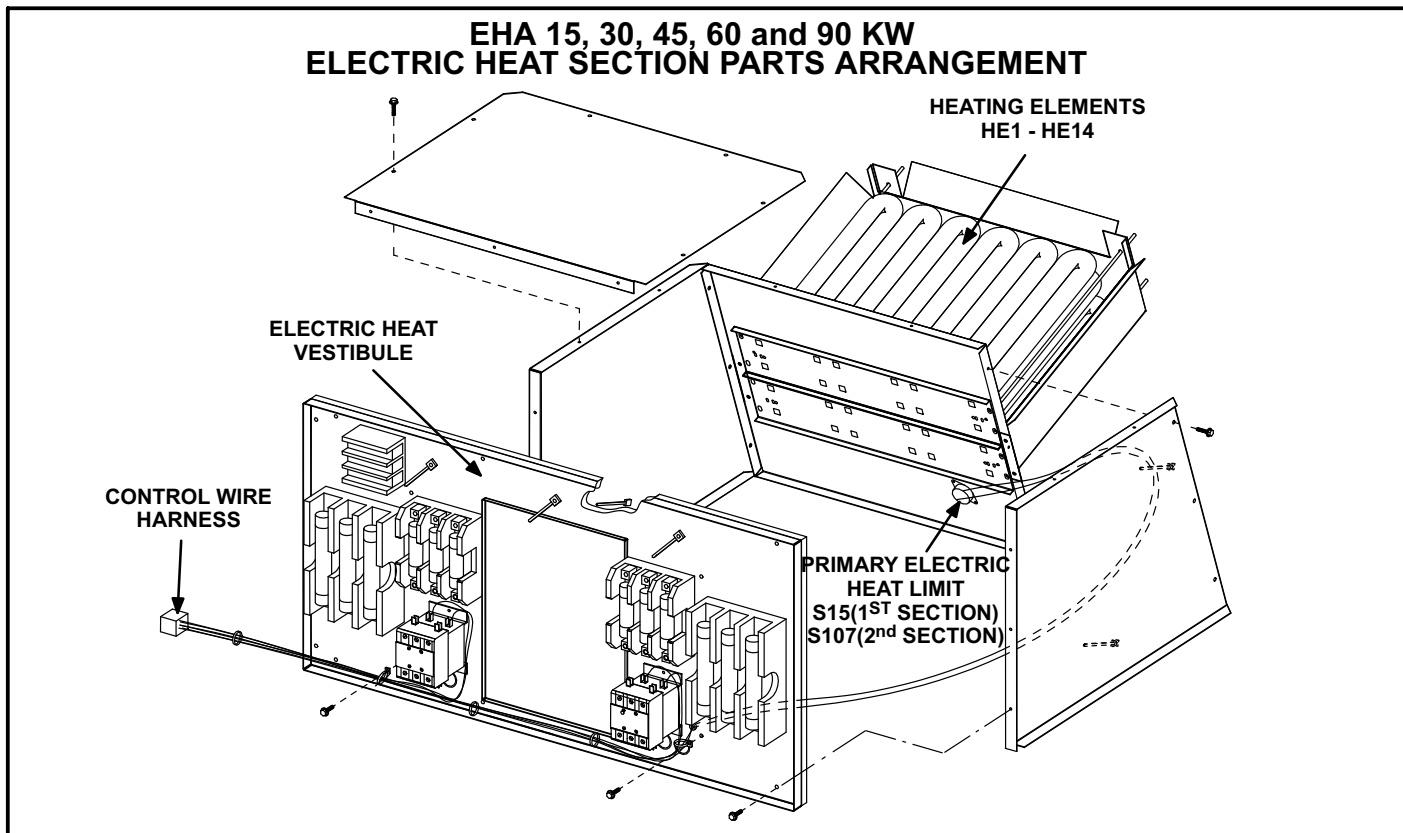


FIGURE 18

TABLE 8

### ELECTRIC HEAT SECTION FUSE RATING

EHA QUANTITY & SIZE	VOLTAGES	FUSE (3 each)							
		F3 - 1	F3 - 2	F3 - 3	F3 - 4	F3 - 5	F3 - 6	F3 - 7	F3 - 8
(1) EHA240-7.5 & (1) EHA240S-7.5 (15 kW Total)	208/230V	50 Amp 250V	---	---	---	---	---	---	---
	460V	25 Amp 600V	---	---	---	---	---	---	---
	575V	20 Amp 600V	---	---	---	---	---	---	---
(1) EHA360-15 & (1) EHA360S-15 (30 kW Total) or (1) EHA156-15 & (1) EHA156S-15	208/230V	60 Amp 250V	60 Amp 250V	---	---	---	---	---	---
	460V	50 Amp 600V	---	---	---	---	---	---	---
	575V	40 Amp 600V	---	---	---	---	---	---	---
(2) EHA360-22.5 (45 kW Total) or (2) EHA156-22.5	208/230V	50 Amp 250V	---	---	25 Amp 250V	50 Amp 250V	---	---	25 Amp 250V
	460V	25 Amp 600V	---	---	15 Amp 600V	25 Amp 600V	---	---	15 Amp 600V
	575V	20 Amp 600V	---	---	10 Amp 600V	20 Amp 600V	---	---	10 Amp 600V
(2) EHA150-30 (60 kW Total) or (2) EHA156-30	208/230V	50 Amp 250V	---	---	50 Amp 250V	50 Amp 250V	---	---	50 Amp 250V
	460V	25 Amp 600V	---	---	25 Amp 600V	25 Amp 600V	---	---	25 Amp 600V
	575V	20 Amp 600V	---	---	20 Amp 600V	20 Amp 600V	---	---	20 Amp 600V
(2) EHA360-45 (90 kW Total)	208/230V	50 Amp 250V	---	60 Amp 250V	60 Amp 250V	50 Amp 250V	---	60 Amp 250V	60 Amp 250V
	460V	25 Amp 600V	---	---	50 Amp 600V	25 Amp 600V	---	---	50 Amp 600V
	575V	20 Amp 600V	---	---	40 Amp 600V	20 Amp 600V	---	---	40 Amp 600V

## II-PLACEMENT AND INSTALLATION

Make sure the unit is installed in accordance with the installation instructions and all applicable codes. See accessories section for conditions requiring use of the optional roof mounting frame (LARMF18/36 or LARMFH18/24).

## III-CHARGING

### WARNING

Refrigerant can be harmful if it is inhaled. Refrigerant must be used and recovered responsibly.

Failure to follow this warning may result in personal injury or death.

### IMPORTANT

Units equipped with Hot Gas Re-Heat system **MUST** be charged in standard cooling mode.

## A-Aluminum Coils

**WARNING-Do not exceed nameplate charge under any condition.**

This unit is factory charged and should require no further adjustment. If the system requires additional refrigerant, reclaim the charge, evacuate the system, and add required nameplate charge.

*NOTE - System charging is not recommended below 60°F (15°C). In temperatures below 60°F (15°C), the charge **must** be weighed into the system.*

If weighing facilities are not available, or to check the charge, use the following procedure:

**IMPORTANT - Charge unit in standard cooling mode.**

- 1 Make sure outdoor coil is clean. Attach gauge manifolds and operate unit at full CFM in cooling mode with econo-

mizer disabled until system stabilizes (approximately five minutes). Make sure all outdoor air dampers are closed.

- 2 Check each system separately with all stages operating. Compare the normal operating pressures (see tables 9 - 21) to the pressures obtained from the gauges. Check unit components if there are significant differences.
- 3 Measure the outdoor ambient temperature and the suction pressure. Refer to the appropriate circuit charging curves to determine a target liquid temperature.

*Note - Pressures are listed for sea level applications.*

- 4 Use the same thermometer to accurately measure the liquid temperature (in the outdoor section).
  - If measured liquid temperature is higher than the target liquid temperature, add refrigerant to the system.
  - If measured liquid temperature is lower than the target liquid temperature, recover some refrigerant from the system.

- 5 Add or remove charge in increments. Allow the system to stabilize each time refrigerant is added or removed.

- 6 Continue the process until measured liquid temperature agrees with the target liquid temperature. Do not go below the target liquid temperature when adjusting charge. Note that suction pressure can change as charge is adjusted.

- 7 Example LGH/LCH180H Circuit 1: At 95°F outdoor ambient and a measured suction pressure of 130psig, the target liquid temperature is 96.5°F. For a measured liquid temperature of 106°F, add charge in increments until measured liquid temperature agrees with the target liquid temperature.

**TABLE 9  
LGH/LCH156H NORMAL OPERATING PRESSURES - ALUMINUM COIL**

Normal Operating Pressures												
	Outdoor Coil Entering Air Temperature											
	65 °F		75 °F		85 °F		95 °F		105 °F		115 °F	
	Suct (psig)	Disc (psig)	Suct (psig)	Disc (psig)	Suct (psig)	Disc (psig)	Suct (psig)	Disc (psig)	Suct (psig)	Disc (psig)	Suct (psig)	Disc (psig)
Circuit 1	110	241	112	279	115	321	117	367	119	419	122	472
	118	245	121	282	124	324	127	370	129	420	131	474
	137	255	140	292	142	333	145	378	148	431	152	484
	154	266	160	304	163	346	163	392	171	441	174	496
Circuit 2	111	249	112	287	113	328	116	374	118	423	121	474
	119	253	120	291	122	332	124	378	127	428	129	481
	137	263	139	301	142	342	145	387	146	438	149	490
	153	276	158	313	162	356	164	402	167	451	171	505
Circuit 3	115	256	116	294	118	335	120	381	122	429	124	480
	123	261	125	299	128	340	130	386	132	436	133	488
	140	273	143	311	146	353	149	398	152	449	154	502
	157	284	162	324	166	367	169	413	171	462	174	515

**TABLE 10  
LGH/LCH156H REHEAT NORMAL OPERATING PRESSURES - ALUMINUM COIL**

Normal Operating Pressures												
	Outdoor Coil Entering Air Temperature											
	65 °F		75 °F		85 °F		95 °F		105 °F		115 °F	
	Suct (psig)	Disc (psig)	Suct (psig)	Disc (psig)	Suct (psig)	Disc (psig)	Suct (psig)	Disc (psig)	Suct (psig)	Disc (psig)	Suct (psig)	Disc (psig)
Circuit 1	113	238	113	278	113	342	115	380	117	450	119	540
	121	242	124	279	123	324	124	375	125	438	127	521
	138	250	141	287	144	328	146	372	145	428	147	492
	156	261	160	298	164	338	167	383	170	432	171	488
Circuit 2	111	244	112	284	114	329	116	384	119	451	121	537
	120	246	121	286	122	331	124	383	127	445	130	518
	138	254	140	290	142	335	143	384	145	439	148	504
	157	264	161	300	164	342	166	390	168	442	170	499
Circuit 3	114	249	115	291	116	340	117	397	120	465	121	552
	123	252	124	294	125	342	126	396	128	459	131	538
	142	261	144	300	145	345	146	397	108	454	150	521
	161	272	165	311	168	355	170	404	172	458	175	516

**TABLE 11  
LGH/LCH156H VAV NORMAL OPERATING PRESSURES - ALUMINUM COIL**

Normal Operating Pressures												
	Outdoor Coil Entering Air Temperature											
	65 °F		75 °F		85 °F		95 °F		105 °F		115 °F	
	Suct (psig)	Disc (psig)	Suct (psig)	Disc (psig)	Suct (psig)	Disc (psig)	Suct (psig)	Disc (psig)	Suct (psig)	Disc (psig)	Suct (psig)	Disc (psig)
Circuit 1	101	232	103	271	104	315	106	372	109	434	111	511
	109	234	111	275	113	317	114	367	118	425	119	500
	128	239	130	277	132	319	134	367	136	420	139	481
	141	245	147	284	153	326	156	373	159	424	158	479
Circuit 2	108	235	110	273	111	320	113	370	115	441	117	531
	117	238	119	276	121	319	123	367	125	426	126	506
	134	246	138	283	140	325	142	372	144	426	146	489
	149	253	156	292	161	334	164	380	167	433	166	490
Circuit 3	119	252	121	291	123	336	125	386	126	445	129	507
	129	256	131	295	133	339	134	387	137	445	139	510
	146	264	150	303	153	346	156	394	158	446	161	505
	161	274	167	313	172	357	176	404	180	456	181	513



**TABLE 12  
LGH/LCH180H CAV/STAGED NORMAL OPERATING PRESSURES - ALUMINUM COIL**

Normal Operating Pressures												
	Outdoor Coil Entering Air Temperature											
	65 °F		75 °F		85 °F		95 °F		105 °F		115 °F	
	Suct (psig)	Disc (psig)	Suct (psig)	Disc (psig)	Suct (psig)	Disc (psig)	Suct (psig)	Disc (psig)	Suct (psig)	Disc (psig)	Suct (psig)	Disc (psig)
Circuit 1	104	235	106	275	105	326	106	389	110	466	113	552
	114	238	118	275	115	319	117	378	119	447	122	527
	130	245	134	281	136	320	136	365	138	424	141	483
	146	253	153	289	157	330	159	374	162	421	165	478
Circuit 2	100	241	103	281	104	327	105	379	109	442	112	513
	111	244	112	282	113	327	115	379	116	445	119	507
	128	249	132	286	131	331	132	377	135	434	139	488
	144	257	151	295	154	336	158	382	158	439	161	498
Circuit 3	106	241	110	278	110	326	111	380	114	447	117	536
	118	242	115	282	120	326	120	380	123	437	126	512
	134	250	138	287	140	328	139	378	142	431	145	491
	151	260	157	298	160	340	163	385	165	435	167	494

**TABLE 13  
LGH/LCH180H CAV/STAGED REHEAT NORMAL OPERATING PRESSURES - ALUMINUM COIL**

Normal Operating Pressures												
	Outdoor Coil Entering Air Temperature											
	65 °F		75 °F		85 °F		95 °F		105 °F		115 °F	
	Suct (psig)	Disc (psig)	Suct (psig)	Disc (psig)	Suct (psig)	Disc (psig)	Suct (psig)	Disc (psig)	Suct (psig)	Disc (psig)	Suct (psig)	Disc (psig)
Circuit 1	103	242	106	277	109	319	110	374	112	444	-	-
	112	243	114	279	117	325	119	368	120	437	122	514
	130	249	133	286	136	326	137	374	139	425	142	489
	143	275	149	306	155	334	158	378	158	417	166	485
Circuit 2	107	249	109	284	110	330	111	374	113	430	-	-
	115	252	116	288	119	334	120	378	121	430	122	492
	131	260	134	297	136	337	138	380	140	436	143	488
Circuit 3	143	287	148	317	156	346	160	391	157	428	167	500
	111	246	112	285	112	342	114	403	116	489	-	-
	119	247	120	288	122	337	123	389	124	471	129	551
	138	254	140	292	142	336	143	383	143	450	147	517
	154	265	159	302	163	341	165	389	168	441	171	505

**TABLE 14  
LGH/LCH180H VAV NORMAL OPERATING PRESSURES - ALUMINUM COIL**

Normal Operating Pressures												
	Outdoor Coil Entering Air Temperature											
	65 °F		75 °F		85 °F		95 °F		105 °F		115 °F	
	Suct (psig)	Disc (psig)	Suct (psig)	Disc (psig)	Suct (psig)	Disc (psig)	Suct (psig)	Disc (psig)	Suct (psig)	Disc (psig)	Suct (psig)	Disc (psig)
Circuit 1	102	234	104	273	106	311	108	358	111	411	114	471
	110	235	112	276	114	314	116	360	119	410	122	470
	123	242	127	283	130	320	132	367	135	418	138	476
	135	251	141	290	145	333	149	380	152	431	155	486
Circuit 2	103	236	105	273	107	315	109	363	111	417	113	472
	110	239	113	276	115	317	117	362	120	415	122	475
	123	246	127	283	132	324	135	370	138	421	141	477
	134	253	141	290	146	332	152	377	156	429	160	481
Circuit 3	115	243	117	280	119	321	121	369	124	419	126	477
	123	246	126	282	128	324	130	368	133	419	135	477
	136	256	141	293	145	334	152	384	152	430	155	485
	150	272	155	304	161	345	166	391	171	439	175	490

**TABLE 15  
LGH/LCH210H NORMAL OPERATING PRESSURES - ALUMINUM COIL**

Normal Operating Pressures												
	Outdoor Coil Entering Air Temperature											
	65 °F		75 °F		85 °F		95 °F		105 °F		115 °F	
	Suct (psig)	Disc (psig)	Suct (psig)	Disc (psig)	Suct (psig)	Disc (psig)	Suct (psig)	Disc (psig)	Suct (psig)	Disc (psig)	Suct (psig)	Disc (psig)
Circuit 1	110	228	113	262	114	302	116	349	118	402	119	466
	119	231	121	266	123	305	125	352	127	405	128	466
	136	238	139	271	141	312	143	358	146	409	149	464
	152	246	157	277	161	319	165	363	169	414	171	472
Circuit 2	112	232	111	267	113	312	115	358	116	414	119	479
	121	235	123	272	125	311	127	357	126	415	129	476
	137	242	141	278	144	317	146	365	149	415	151	471
	153	253	159	289	164	333	168	374	171	425	174	478
Circuit 3	105	241	106	284	108	327	110	375	112	429	115	489
	112	244	115	282	118	323	121	369	121	428	123	487
	130	251	132	289	135	332	138	378	141	428	145	484
	146	261	151	297	156	339	159	386	163	437	165	495

**TABLE 16  
LGH/LCH210H REHEAT NORMAL OPERATING PRESSURES - ALUMINUM COIL**

Normal Operating Pressures												
	Outdoor Coil Entering Air Temperature											
	65 °F		75 °F		85 °F		95 °F		105 °F		115 °F	
	Suct (psig)	Disc (psig)	Suct (psig)	Disc (psig)	Suct (psig)	Disc (psig)	Suct (psig)	Disc (psig)	Suct (psig)	Disc (psig)	Suct (psig)	Disc (psig)
Circuit 1	109	234	111	270	114	311	115	357	118	410	121	472
	119	237	120	274	122	314	125	360	127	412	130	472
	137	246	140	281	143	321	146	365	146	417	150	473
	152	260	158	292	162	330	166	373	170	421	173	476
Circuit 2	113	240	115	276	114	320	115	369	117	420	122	478
	122	244	123	281	125	321	125	369	127	423	130	481
	139	254	143	291	146	330	148	374	150	424	152	480
	154	267	160	302	165	341	169	384	172	431	176	486
Circuit 3	111	239	113	277	116	319	115	371	117	427	121	488
	119	243	128	281	123	326	125	374	127	430	130	489
	135	252	139	291	143	332	145	379	148	432	150	490
	149	265	155	303	160	344	164	390	168	438	173	496

**TABLE 17  
LGH/LCH240H CAV/STAGED NORMAL OPERATING PRESSURES - ALUMINUM COIL**

Normal Operating Pressures												
	Outdoor Coil Entering Air Temperature											
	65 °F		75 °F		85 °F		95 °F		105 °F		115 °F	
	Suct (psig)	Disc (psig)	Suct (psig)	Disc (psig)	Suct (psig)	Disc (psig)	Suct (psig)	Disc (psig)	Suct (psig)	Disc (psig)	Suct (psig)	Disc (psig)
Circuit 1	107	249	109	286	111	331	113	391	116	450	118	513
	115	251	118	285	120	332	122	383	125	443	128	513
	134	255	136	291	139	334	141	383	143	441	146	506
	156	269	160	305	164	352	163	393	166	451	168	508
Circuit 2	105	236	106	277	109	320	112	373	114	445	116	538
	114	239	116	275	117	323	119	372	122	438	125	530
	131	245	134	279	136	322	138	372	140	427	144	489
	153	257	157	291	161	337	161	377	164	433	167	486
Circuit 3	110	247	112	286	114	330	115	386	117	444	119	507
	119	251	121	289	122	334	123	384	126	442	128	512
	136	259	139	298	141	341	144	389	145	445	147	506
	157	276	162	314	166	358	166	399	168	457	170	511
Circuit 4	104	240	106	276	108	319	110	372	111	435	115	492
	113	244	114	280	117	320	117	371	120	432	123	497
	128	251	131	289	133	331	136	376	139	430	142	486
	149	264	154	301	157	345	157	387	161	442	165	493

**TABLE 18  
LGH/LCH240H CAV/STAGED REHEAT NORMAL OPERATING PRESSURES - ALUMINUM COIL**

Normal Operating Pressures												
	Outdoor Coil Entering Air Temperature											
	65 °F		75 °F		85 °F		95 °F		105 °F		115 °F	
	Suct (psig)	Disc (psig)	Suct (psig)	Disc (psig)	Suct (psig)	Disc (psig)	Suct (psig)	Disc (psig)	Suct (psig)	Disc (psig)	Suct (psig)	Disc (psig)
Circuit 1	111	252	112	288	112	334	114	386	116	441	118	502
	119	256	121	294	122	337	123	387	125	440	127	499
	136	266	140	303	142	345	145	391	147	446	148	499
	140	268	155	314	160	356	164	402	168	451	172	505
Circuit 2	108	246	109	282	110	326	112	379	114	438	116	512
	116	248	118	286	119	330	120	379	122	426	125	501
	133	257	137	294	138	335	140	382	142	440	145	494
	138	259	152	303	158	345	161	390	165	437	168	492
Circuit 3	115	248	117	285	118	327	121	375	124	426	127	479
	121	252	125	290	128	332	129	378	131	429	135	484
	135	260	140	299	144	341	148	388	152	442	153	493
	141	262	154	308	160	353	164	399	169	450	173	504
Circuit 4	112	243	114	278	115	319	118	365	116	425	120	479
	118	246	122	283	125	324	126	369	127	418	129	479
	133	254	137	291	141	332	145	377	148	430	150	481
	138	257	151	301	157	344	161	389	166	437	170	491

**TABLE 19  
LGH/LCH240H VAV NORMAL OPERATING PRESSURES - ALUMINUM COIL**

Normal Operating Pressures												
	Outdoor Coil Entering Air Temperature											
	65 °F		75 °F		85 °F		95 °F		105 °F		115 °F	
	Suct (psig)	Disc (psig)	Suct (psig)	Disc (psig)	Suct (psig)	Disc (psig)	Suct (psig)	Disc (psig)	Suct (psig)	Disc (psig)	Suct (psig)	Disc (psig)
Circuit 1	98	238	101	276	102	318	105	367	108	413	110	467
	107	240	109	278	111	321	113	368	116	418	119	474
	124	248	127	284	129	325	132	372	134	422	137	478
	143	255	145	293	148	333	152	380	154	428	157	482
Circuit 2	101	230	103	267	105	309	108	360	110	407	113	462
	109	232	111	268	113	311	116	358	118	411	121	467
	125	239	129	274	132	315	135	362	137	413	140	471
	141	245	145	283	150	323	154	371	158	419	161	474
Circuit 3	113	249	115	287	117	329	119	381	121	432	123	488
	122	252	124	290	126	333	127	381	129	434	131	492
	139	263	142	299	145	341	147	388	149	441	152	498
	159	275	159	313	164	353	167	402	169	451	172	508
Circuit 4	117	242	119	281	120	324	122	377	124	428	127	486
	125	246	127	285	129	329	131	377	133	430	135	490
	139	256	145	293	148	335	151	389	153	436	156	495
	158	268	161	308	166	348	171	396	174	446	177	504

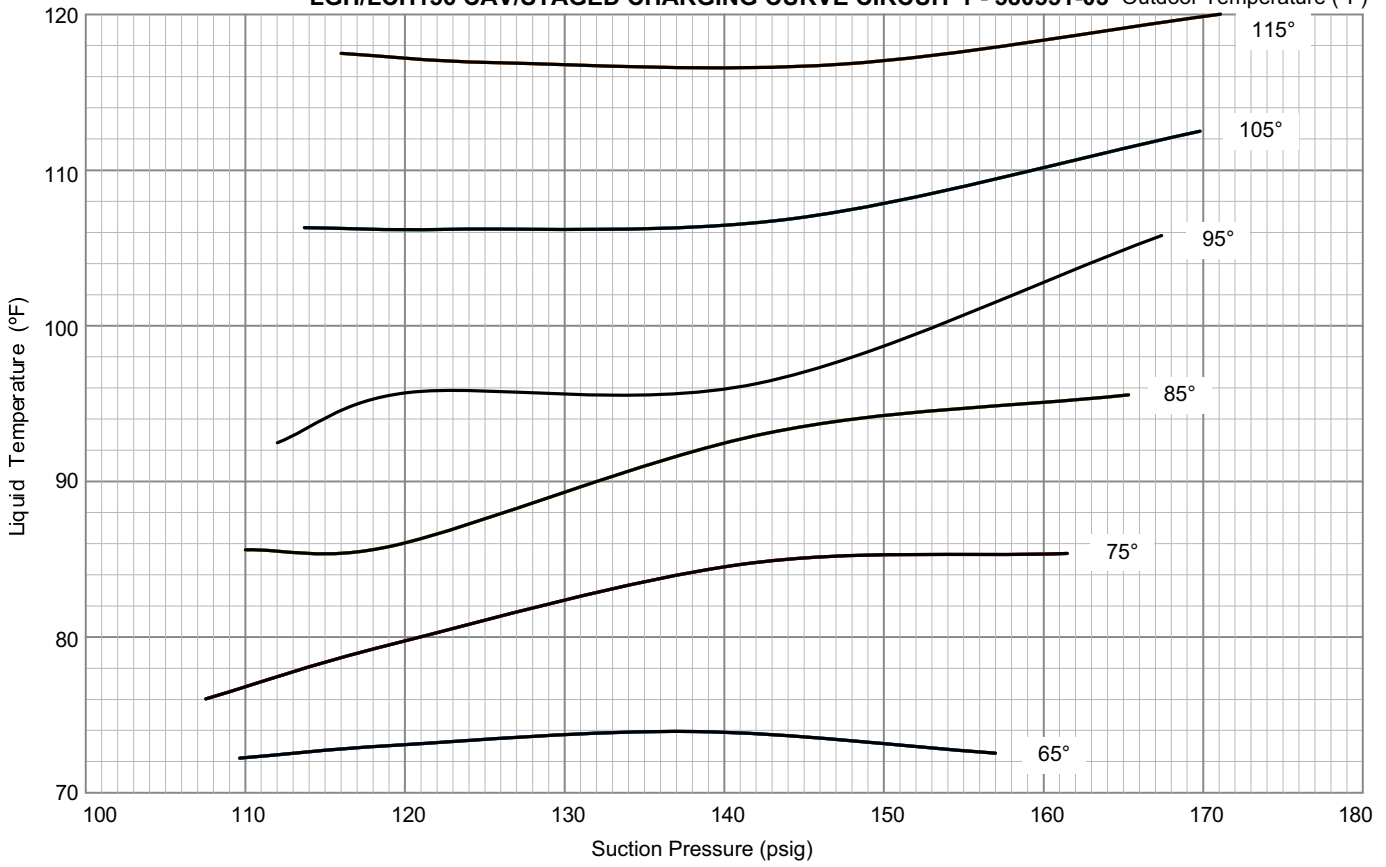
**TABLE 20  
LGH/LCH300S NORMAL OPERATING PRESSURES - ALUMINUM COIL**

Normal Operating Pressures												
	Outdoor Coil Entering Air Temperature											
	65 °F		75 °F		85 °F		95 °F		105 °F		115 °F	
	Suct (psig)	Disc (psig)	Suct (psig)	Disc (psig)	Suct (psig)	Disc (psig)	Suct (psig)	Disc (psig)	Suct (psig)	Disc (psig)	Suct (psig)	Disc (psig)
Circuit 1	105	248	109	283	109	330	110	381	112	432	114	486
	114	250	117	291	117	338	119	384	121	432	123	487
	127	253	134	300	137	343	140	388	141	444	144	501
	142	265	149	308	154	349	159	399	163	449	167	503
Circuit 2	103	236	105	272	107	318	108	373	109	428	111	484
	112	238	114	278	116	325	116	374	118	425	120	482
	127	246	131	285	135	327	137	377	140	433	142	491
	141	254	146	294	150	332	156	385	160	437	164	495
Circuit 3	104	258	105	302	107	345	109	399	111	456	114	519
	112	263	114	308	115	354	117	403	120	463	123	524
	131	297	133	320	136	367	138	410	140	465	142	526
	147	313	147	334	152	381	156	423	160	476	165	537
Circuit 4	100	246	103	289	104	329	105	381	107	437	110	500
	109	253	110	293	112	337	114	383	116	443	119	505
	126	281	127	303	131	349	133	391	136	443	139	499
	141	296	143	321	149	370	152	410	157	462	161	521

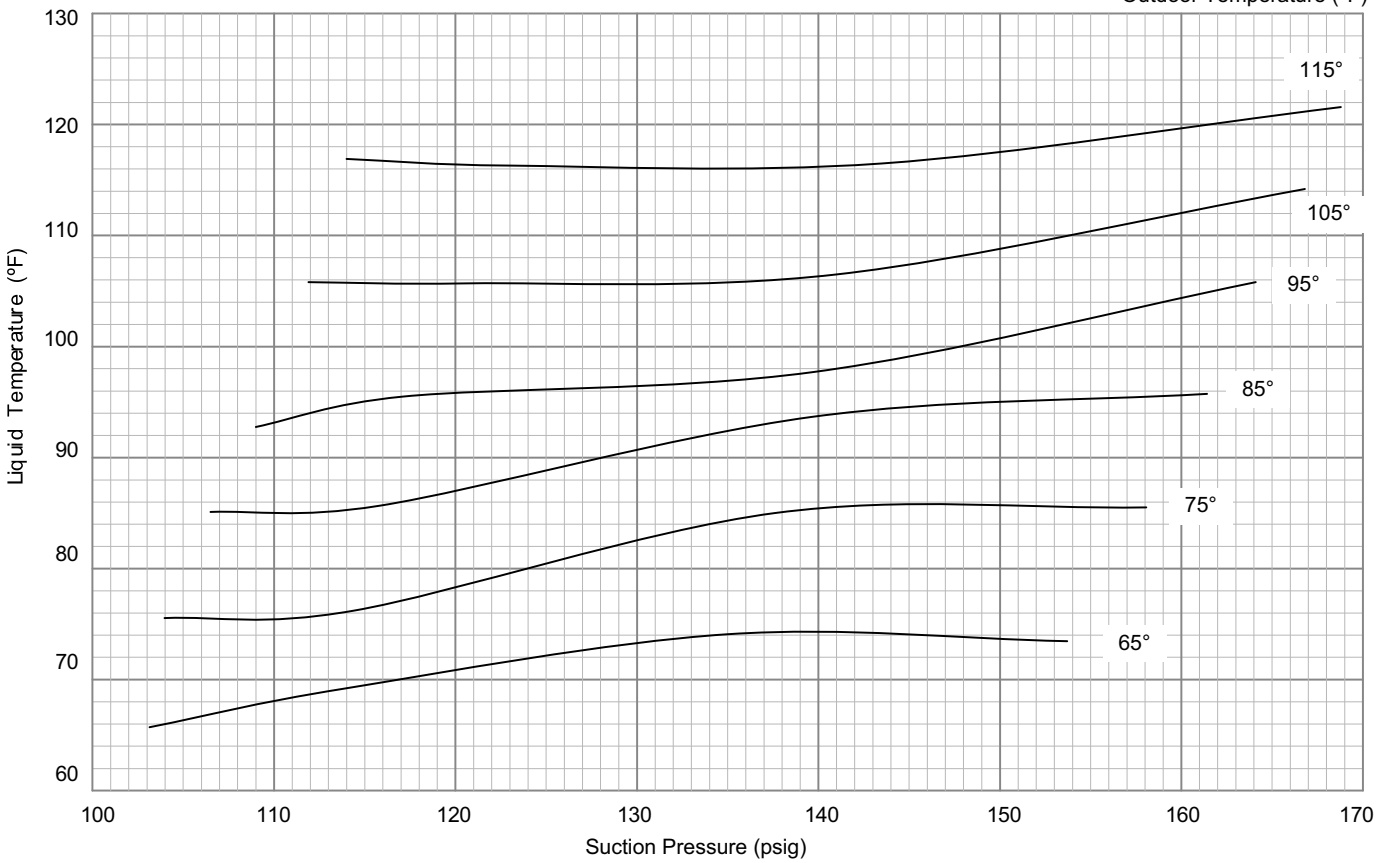
**TABLE 21  
LGH/LCH300S REHEAT NORMAL OPERATING PRESSURES - ALUMINUM COIL**

Normal Operating Pressures												
	Outdoor Coil Entering Air Temperature											
	65 °F		75 °F		85 °F		95 °F		105 °F		115 °F	
	Suct (psig)	Disc (psig)	Suct (psig)	Disc (psig)	Suct (psig)	Disc (psig)	Suct (psig)	Disc (psig)	Suct (psig)	Disc (psig)	Suct (psig)	Disc (psig)
Circuit 1	108	259	110	299	112	353	113	396	114	452	117	510
	118	263	119	303	120	348	123	396	125	450	128	510
	133	275	137	314	139	357	142	407	144	460	148	516
	149	288	154	326	159	370	162	416	166	468	171	527
Circuit 2	106	253	107	293	109	348	111	389	113	445	115	509
	116	257	118	296	119	340	120	391	122	445	125	506
	133	267	136	307	139	349	142	398	142	452	145	512
	148	280	153	318	158	360	161	407	164	460	168	521
Circuit 3	110	258	109	304	110	363	111	405	113	463	116	535
	119	263	122	304	123	350	122	405	124	463	126	526
	135	274	139	316	142	360	145	410	148	463	151	520
	149	288	155	329	159	375	163	422	168	475	172	536
Circuit 4	105	251	107	290	107	347	109	390	110	449	113	511
	114	256	117	294	119	338	119	388	121	446	123	509
	128	268	133	308	136	349	139	397	142	449	144	510
	141	282	147	320	152	363	156	408	160	462	165	521

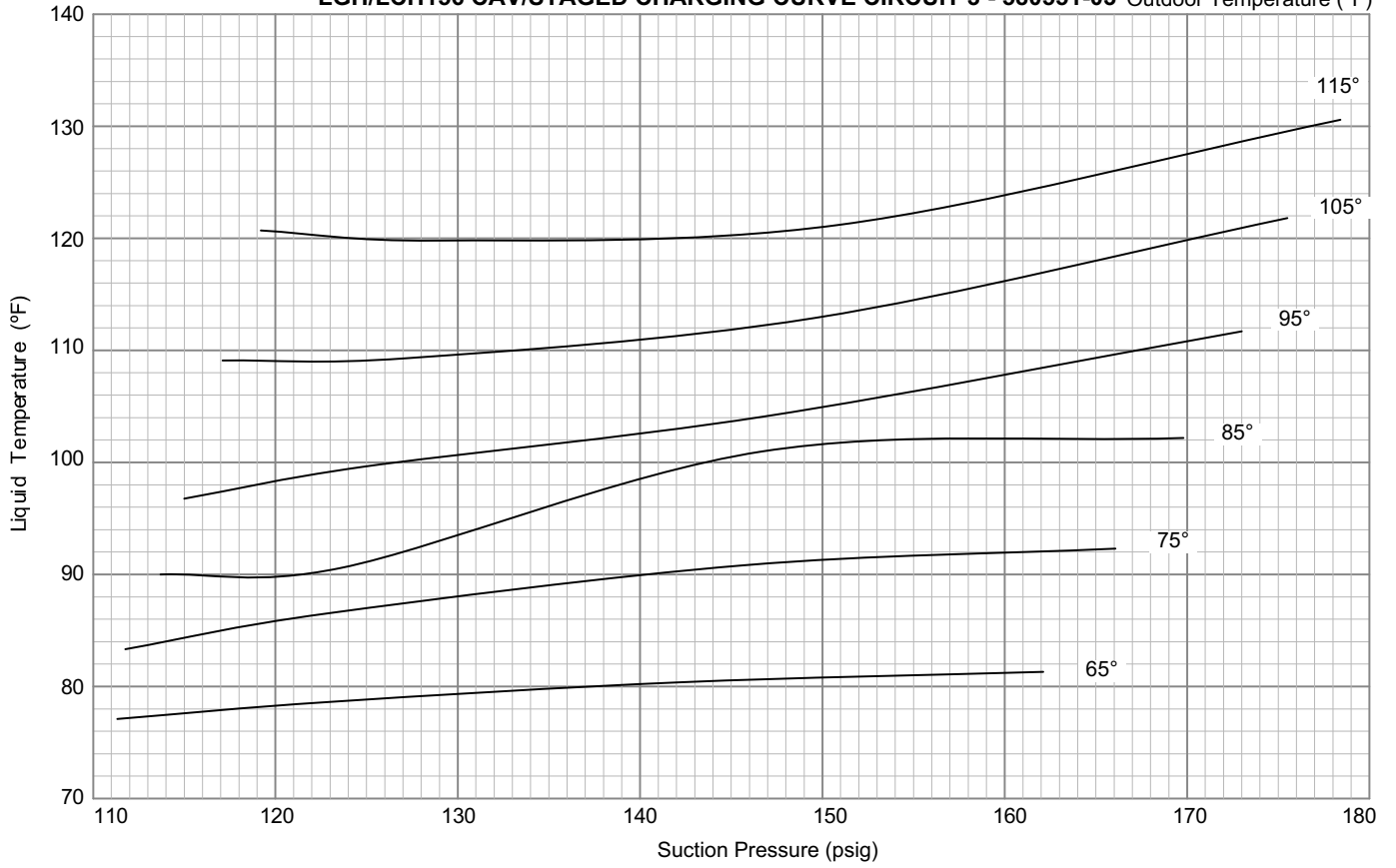
**LGH/LCH156 CAV/STAGED CHARGING CURVE CIRCUIT 1 - 580551-03** Outdoor Temperature (°F)



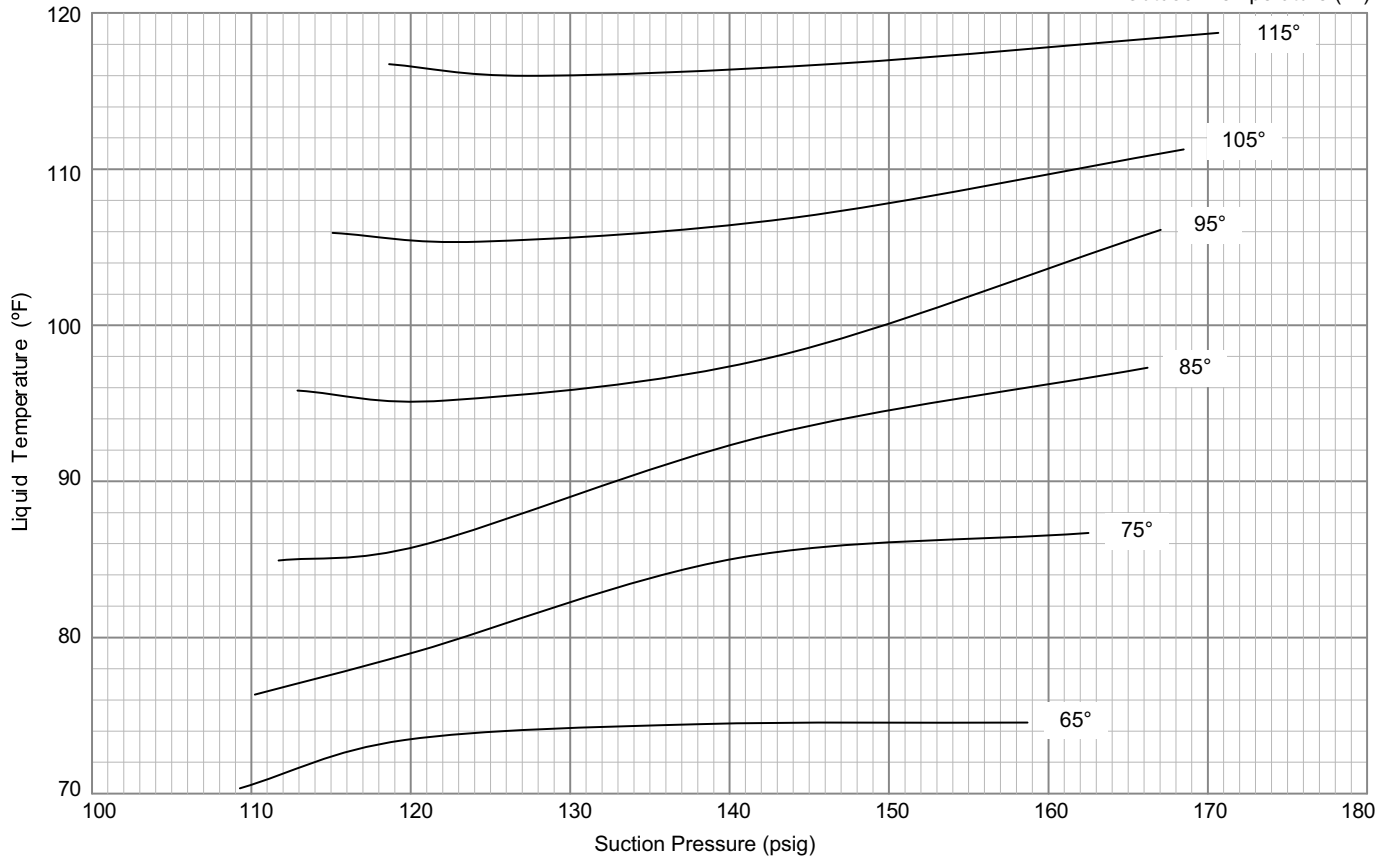
**LGH/LCH156 CAV/STAGED CHARGING CURVE CIRCUIT 2 - 580551-03** Outdoor Temperature (°F)



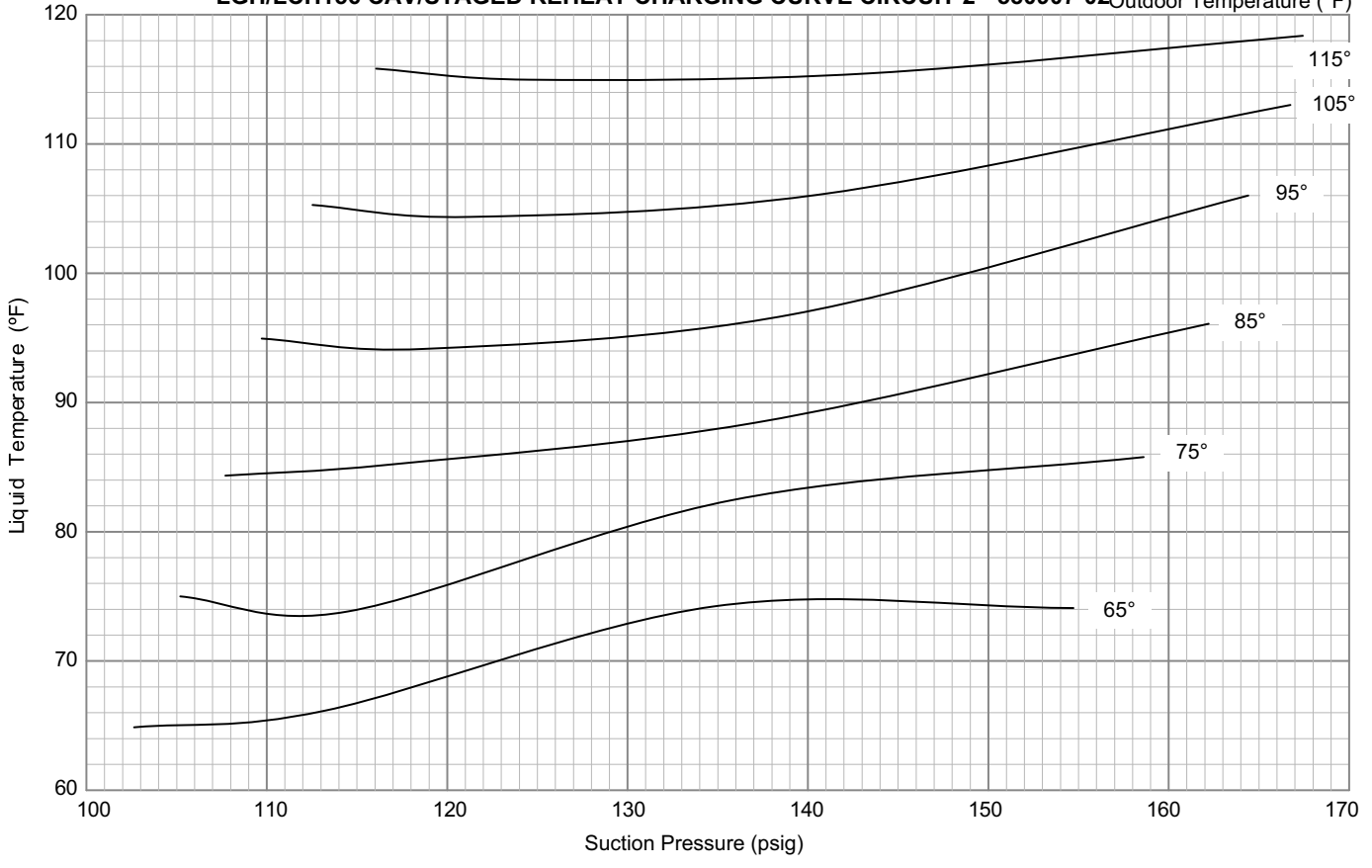
**LGH/LCH156 CAV/STAGED CHARGING CURVE CIRCUIT 3 - 580551-03** Outdoor Temperature (°F)



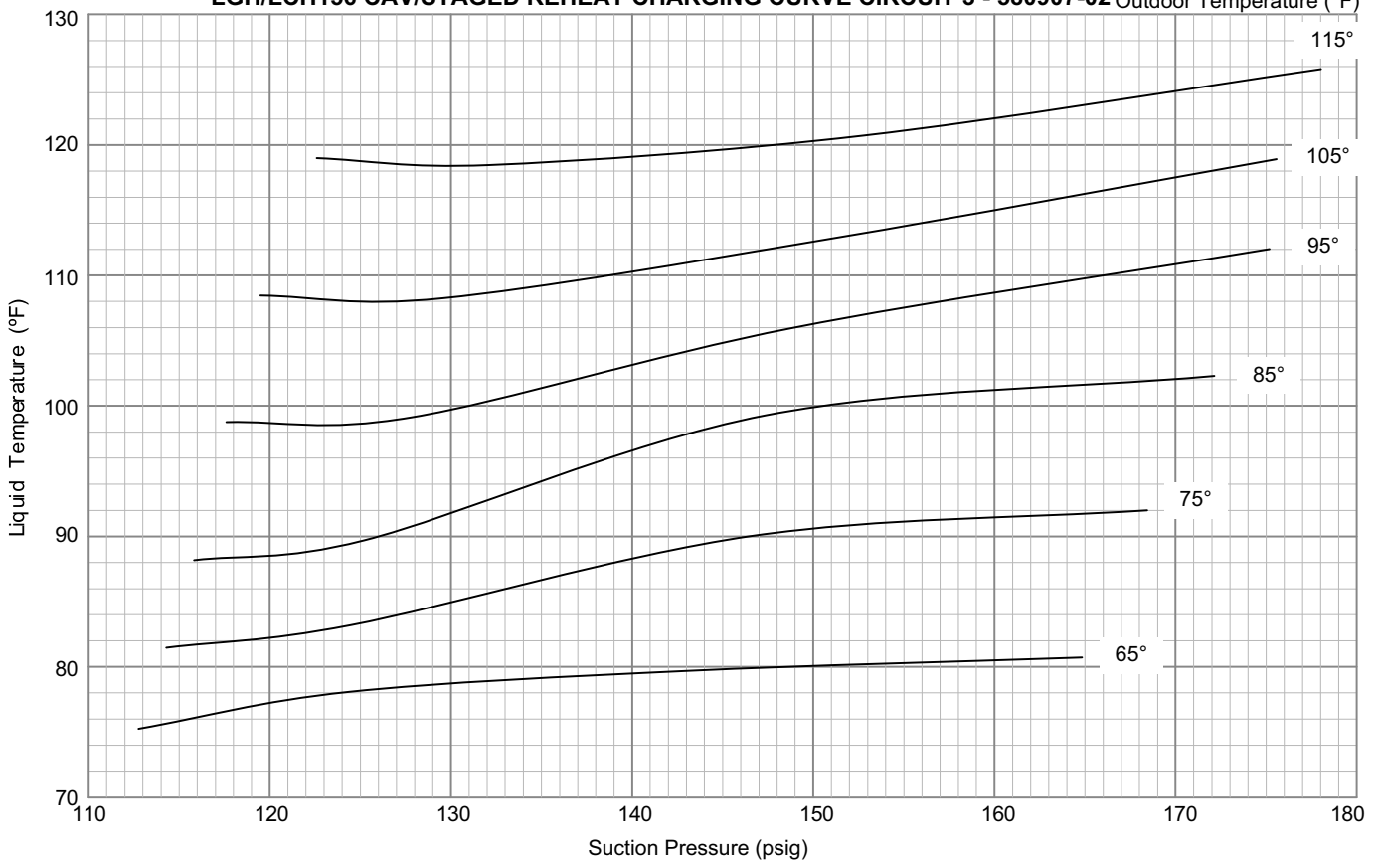
**LGH/LCH156 CAV/STAGED REHEAT CHARGING CURVES CIRCUIT 1 - 580907-02** Outdoor Temperature (°F)



**LGH/LCH156 CAV/STAGED REHEAT CHARGING CURVE CIRCUIT 2 - 580907-02** Outdoor Temperature (°F)

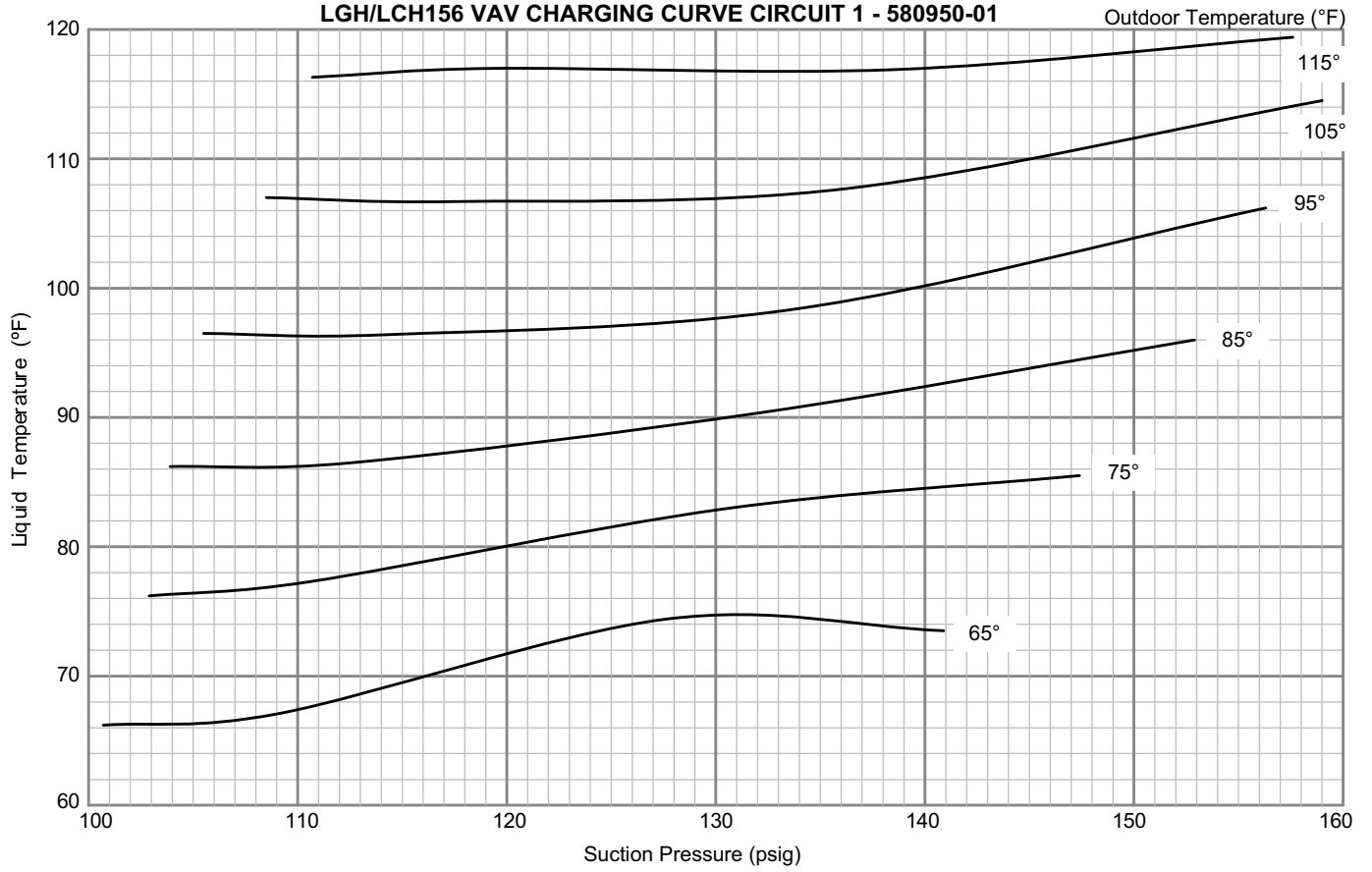


**LGH/LCH156 CAV/STAGED REHEAT CHARGING CURVE CIRCUIT 3 - 580907-02** Outdoor Temperature (°F)

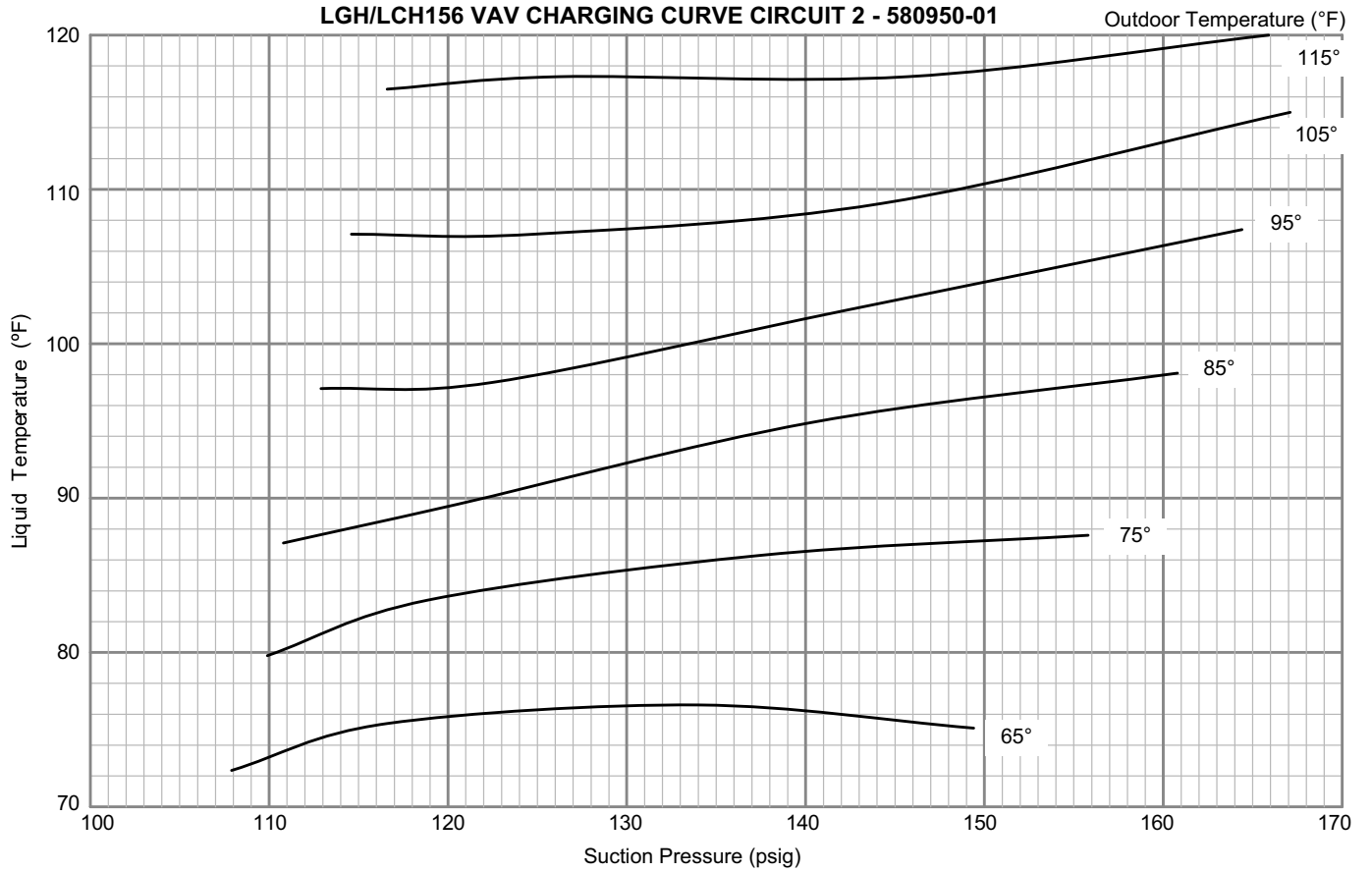




**LGH/LCH156 VAV CHARGING CURVE CIRCUIT 1 - 580950-01**

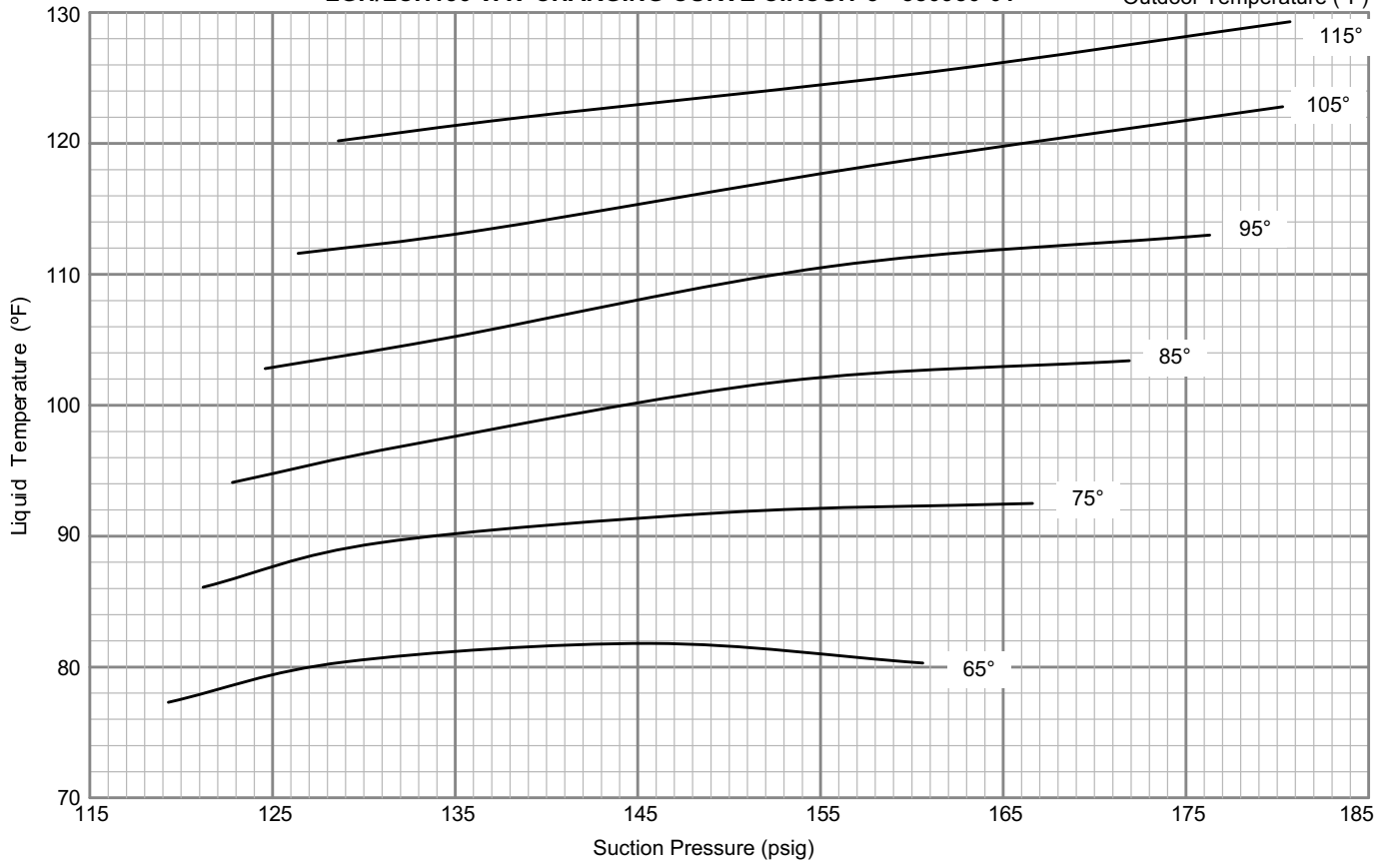


**LGH/LCH156 VAV CHARGING CURVE CIRCUIT 2 - 580950-01**



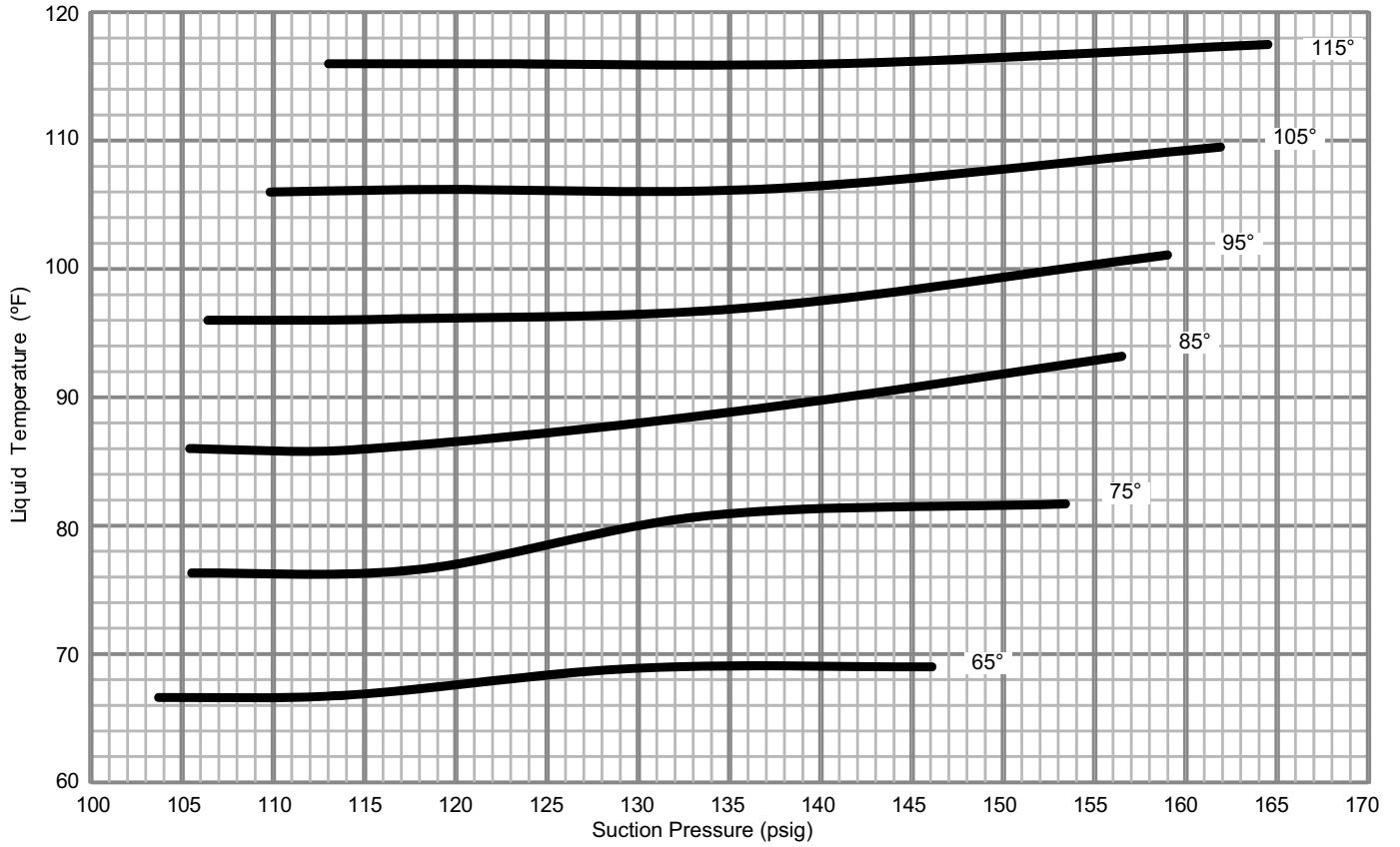
LGH/LCH156 VAV CHARGING CURVE CIRCUIT 3 - 580950-01

Outdoor Temperature (°F)



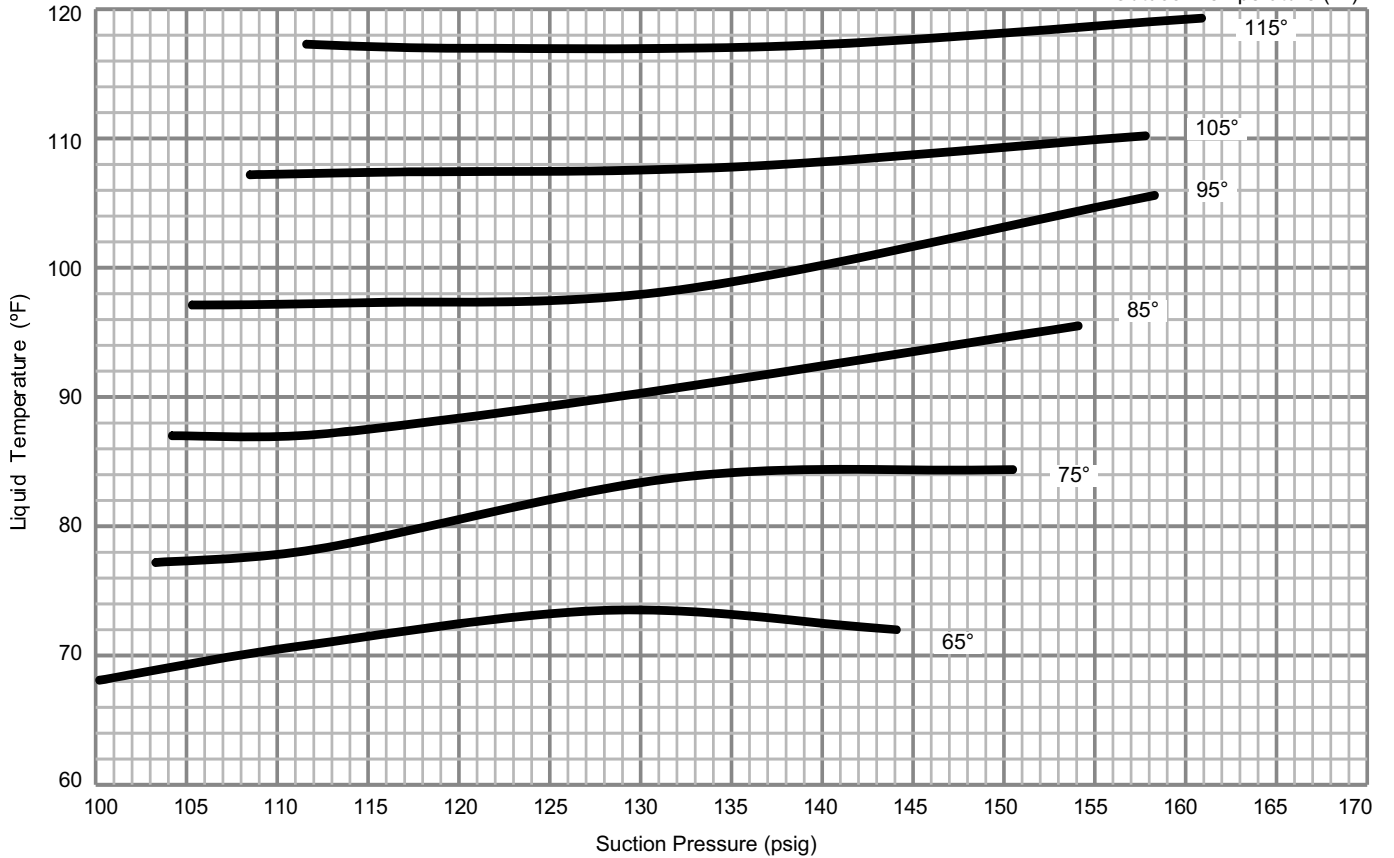
**LGH/LCH180 CAV/STAGED CHARGING CURVES CIRCUIT 1**

Outdoor Temperature (°F)

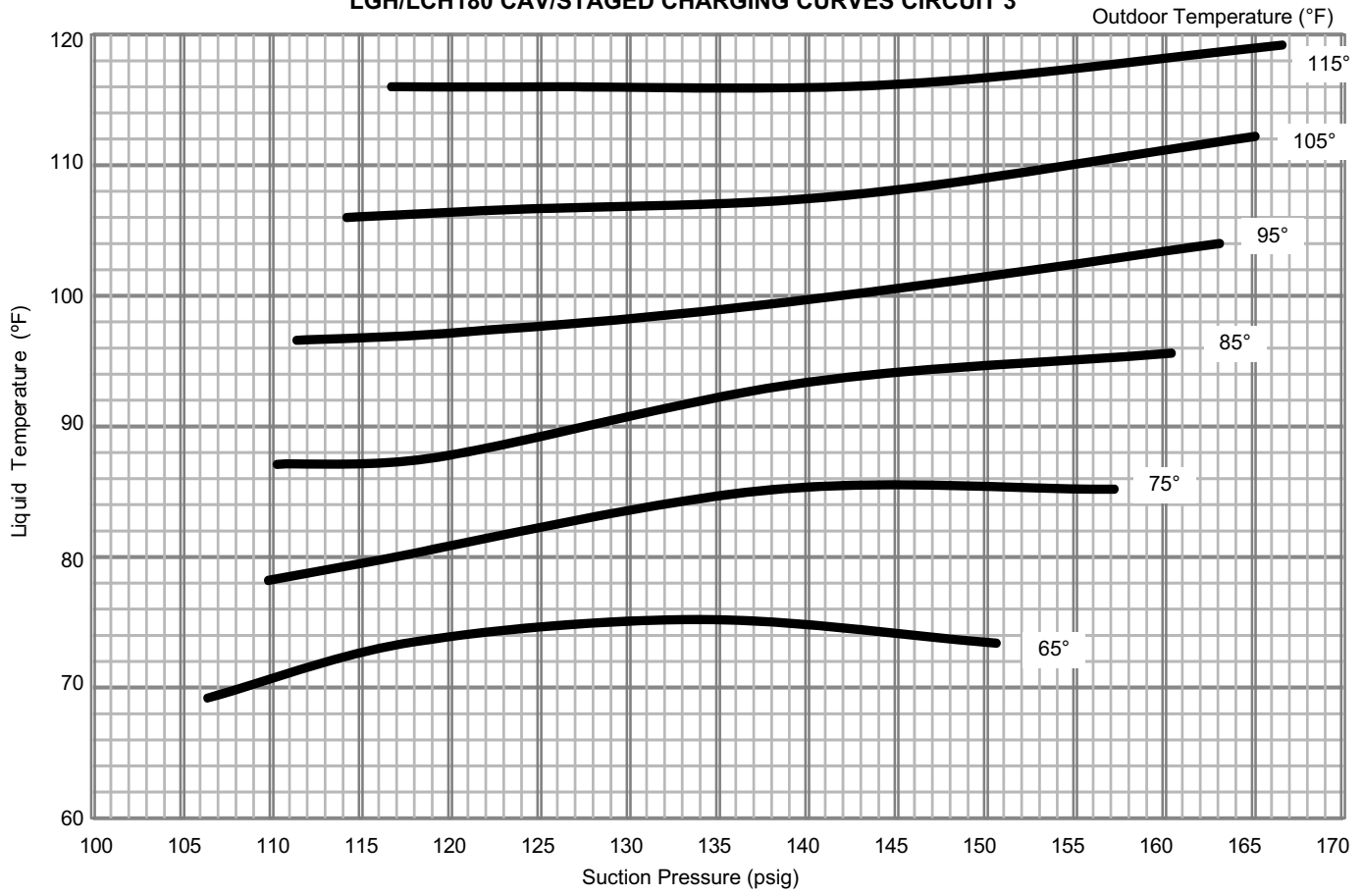


**LGH/LCH180 CAV/STAGED CHARGING CURVES CIRCUIT 2**

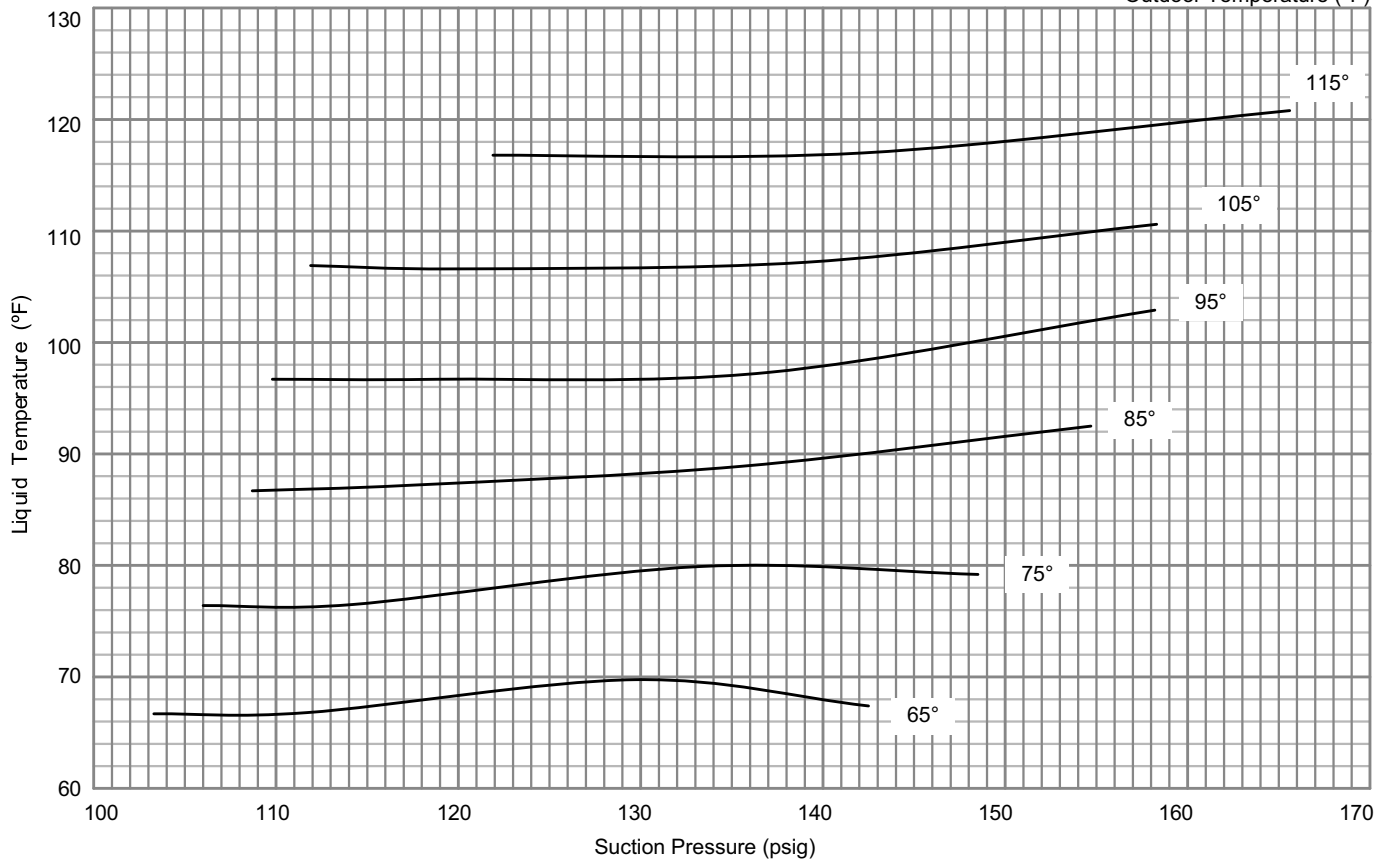
Outdoor Temperature (°F)



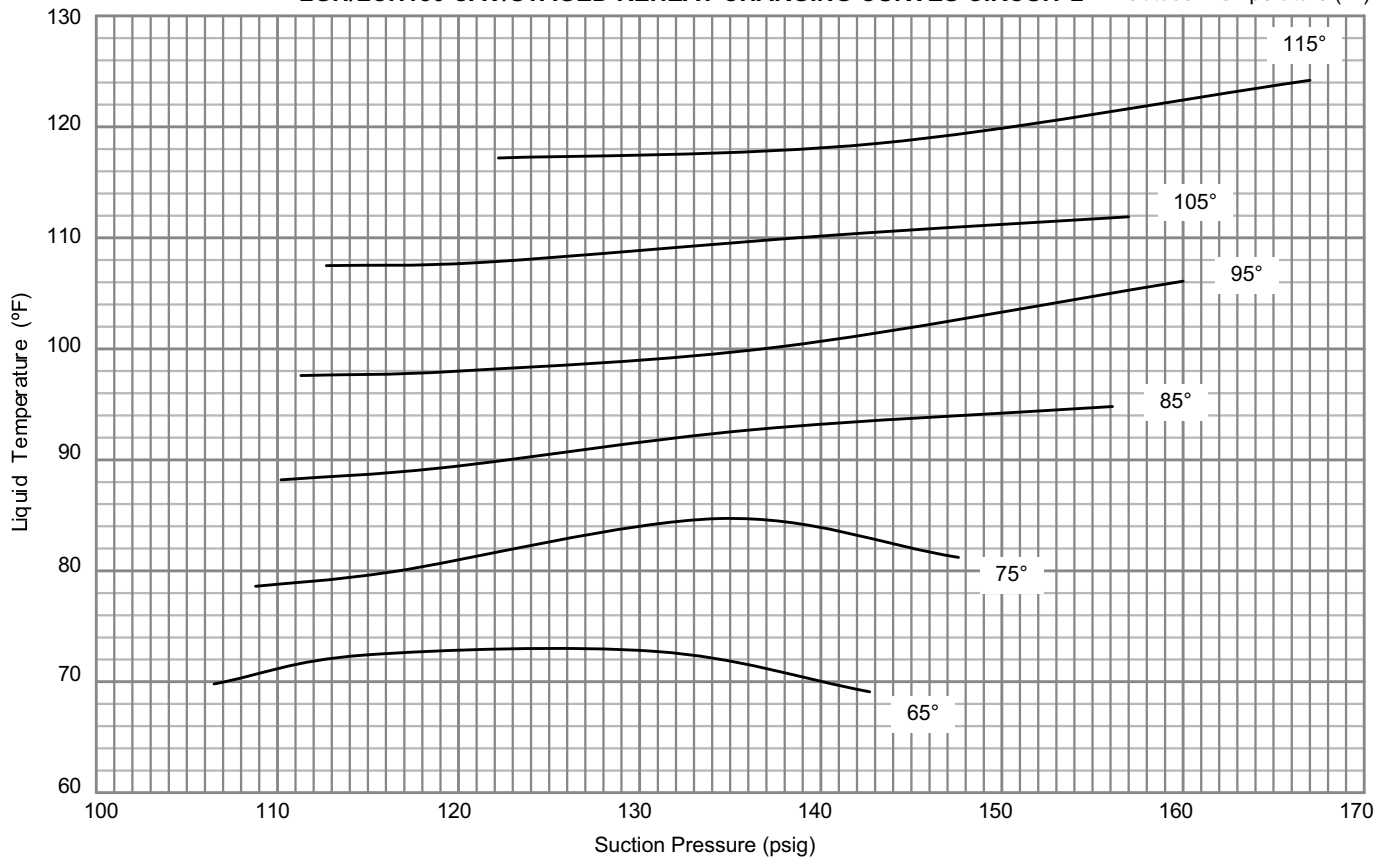
### LGH/LCH180 CAV/STAGED CHARGING CURVES CIRCUIT 3



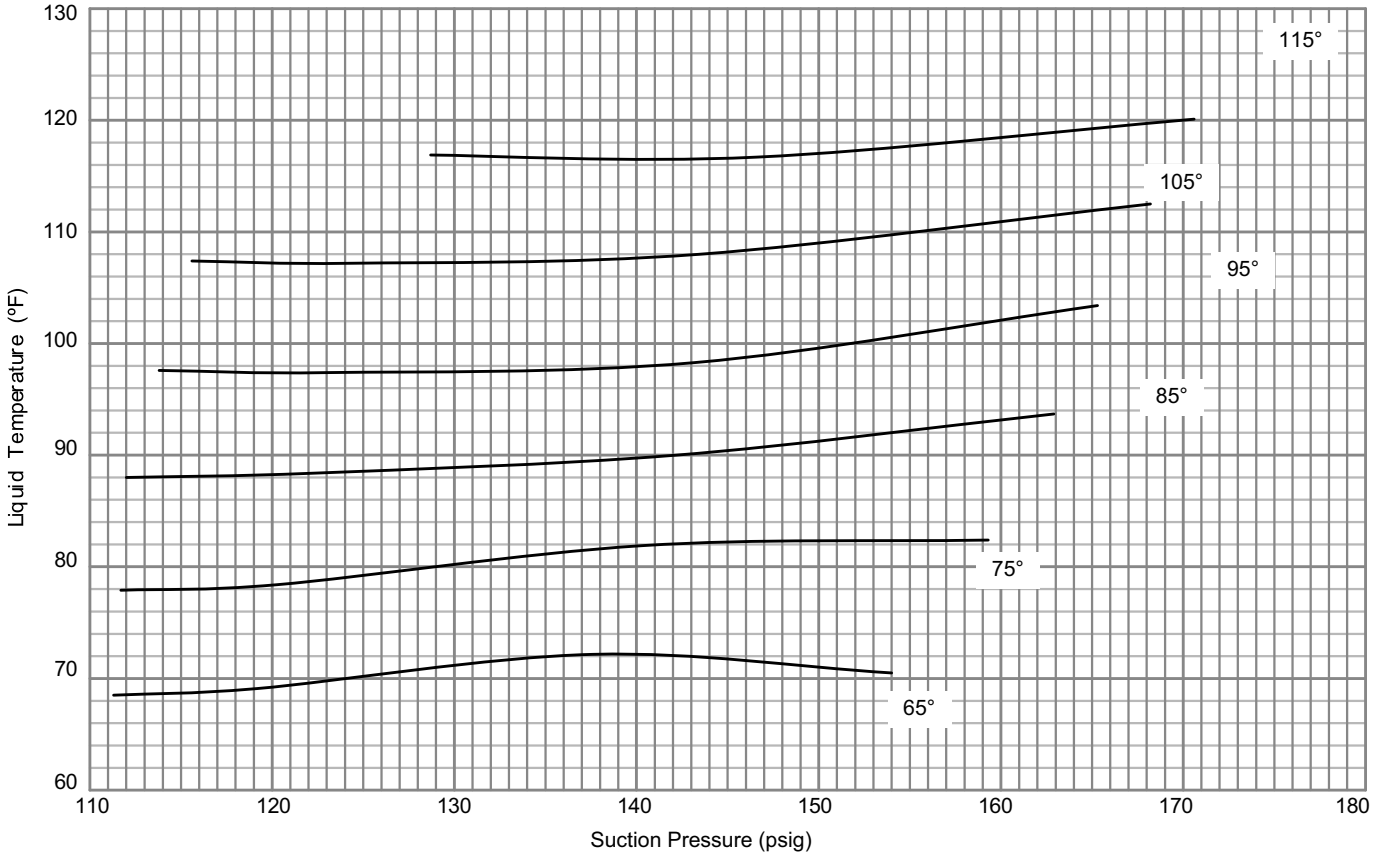
**LGH/LCH180 CAV/STAGED REHEAT CHARGING CURVES CIRCUIT 1** Outdoor Temperature (°F)



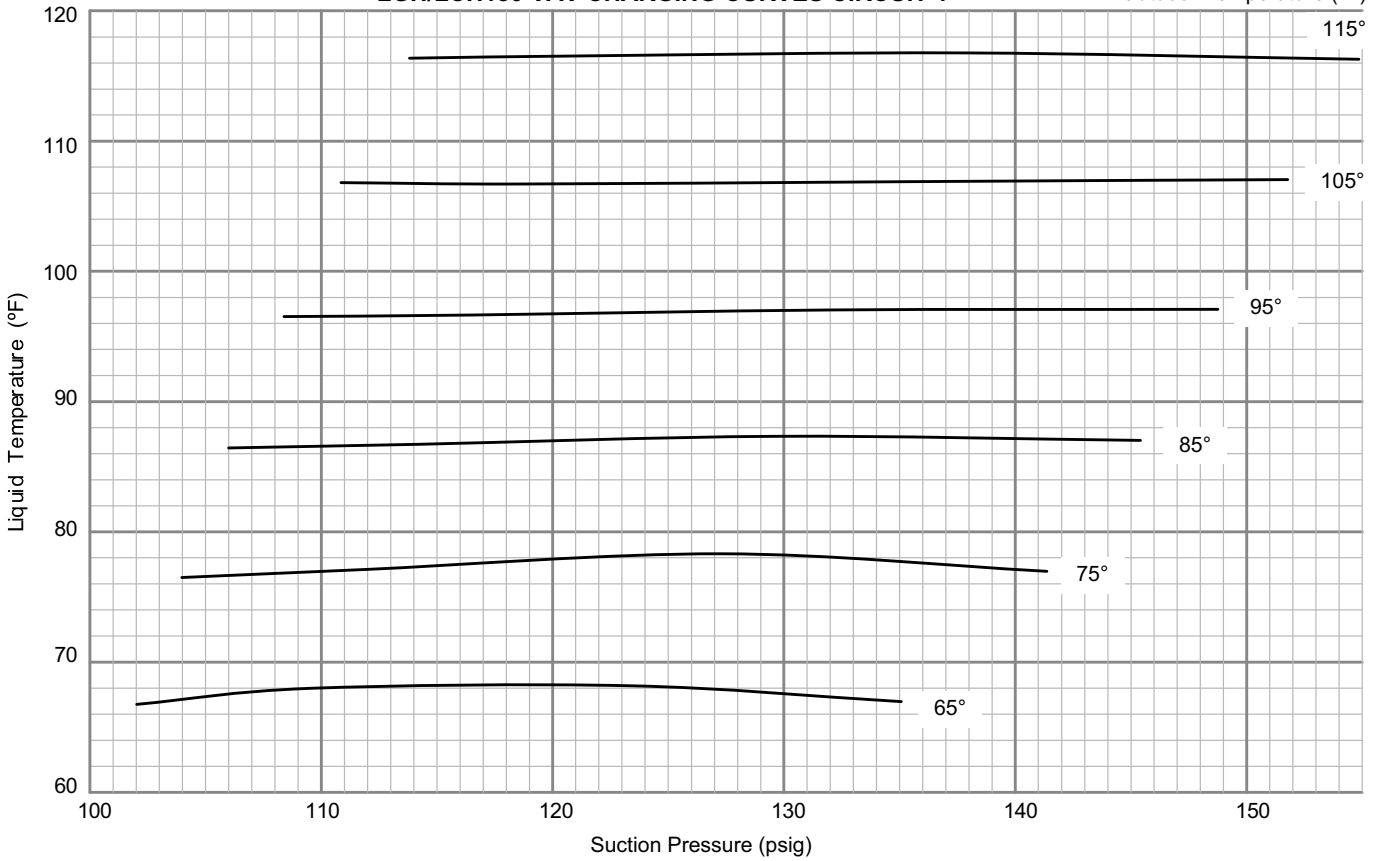
**LGH/LCH180 CAV/STAGED REHEAT CHARGING CURVES CIRCUIT 2** Outdoor Temperature (°F)



**LGH/LCH180 CAV/STAGED REHEAT CHARGING CURVES CIRCUIT 3** Outdoor Temperature (°F)

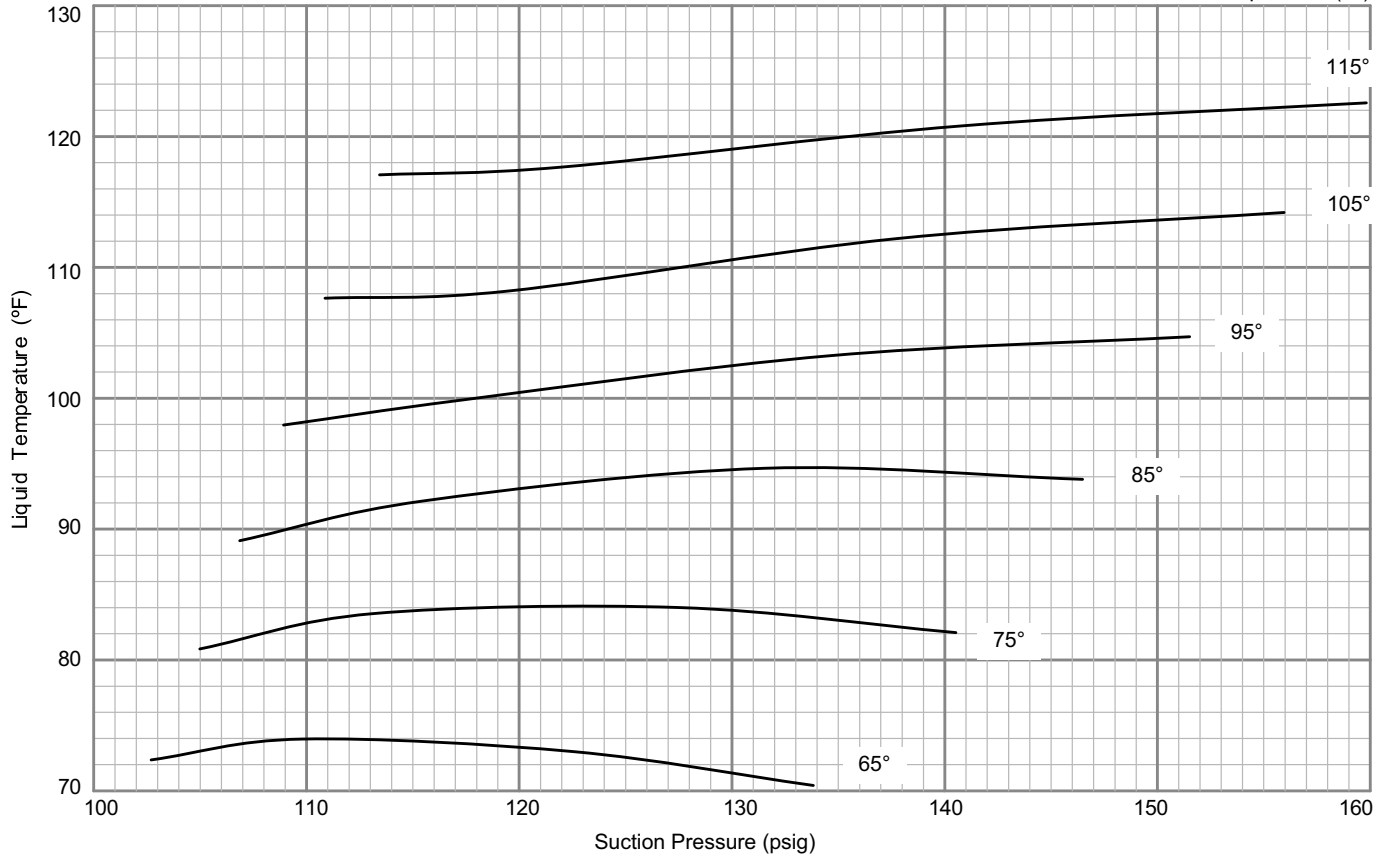


**LGH/LCH180 VAV CHARGING CURVES CIRCUIT 1** Outdoor Temperature (°F)



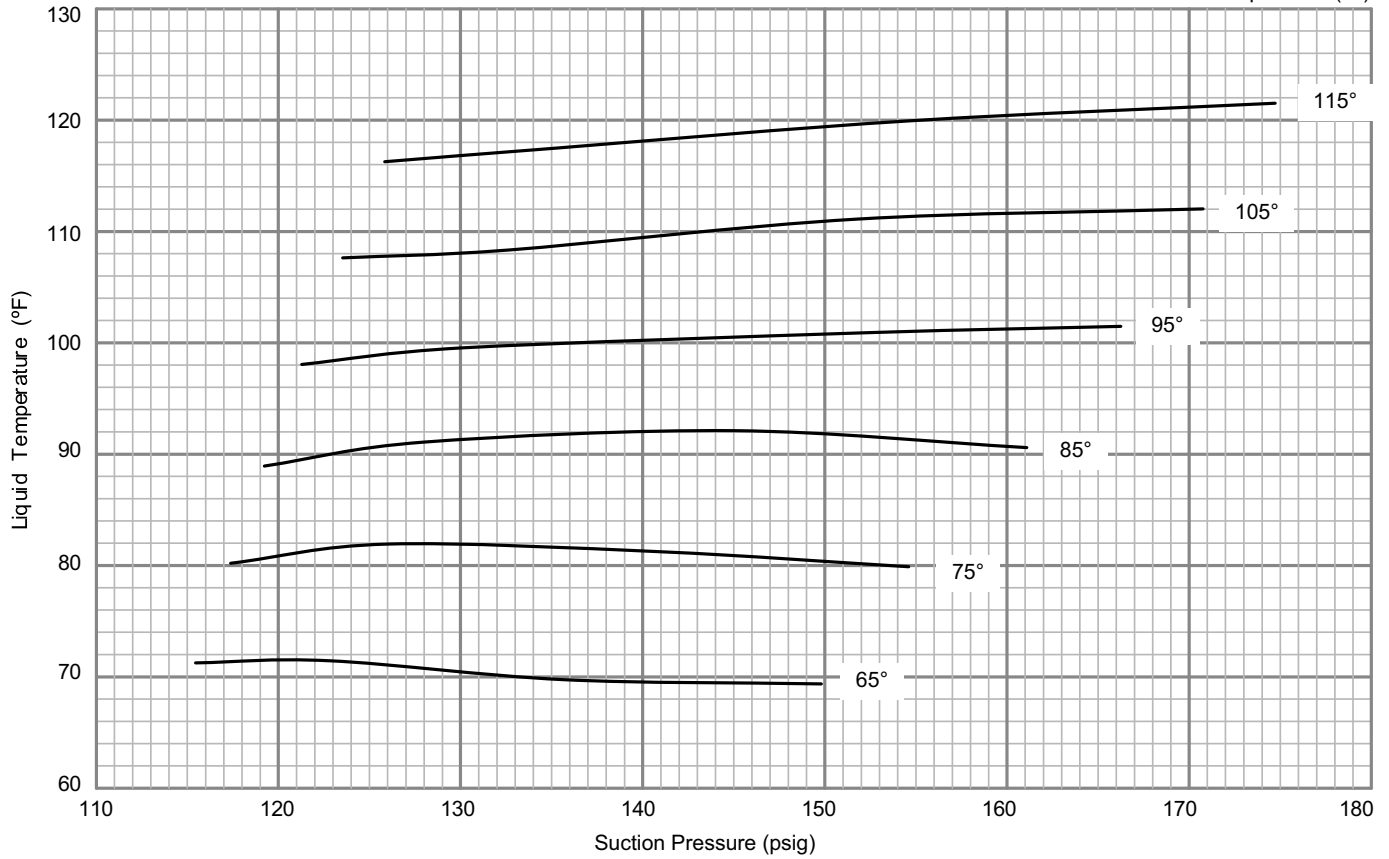
**LGH/LCH180 VAV CHARGING CURVES CIRCUIT 2**

Outdoor Temperature (°F)



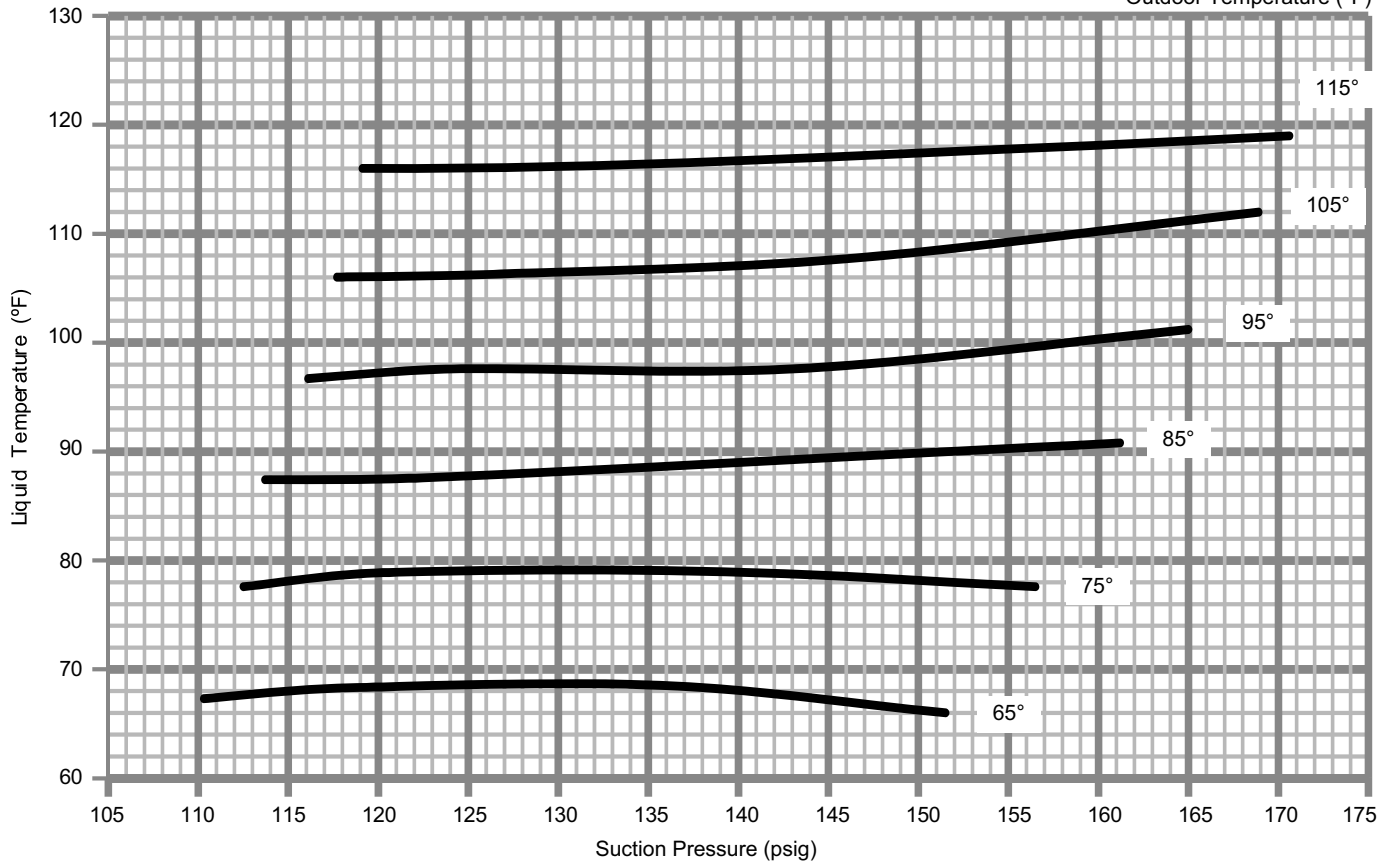
**LGH/LCH180 VAV CHARGING CURVES CIRCUIT 3**

Outdoor Temperature (°F)



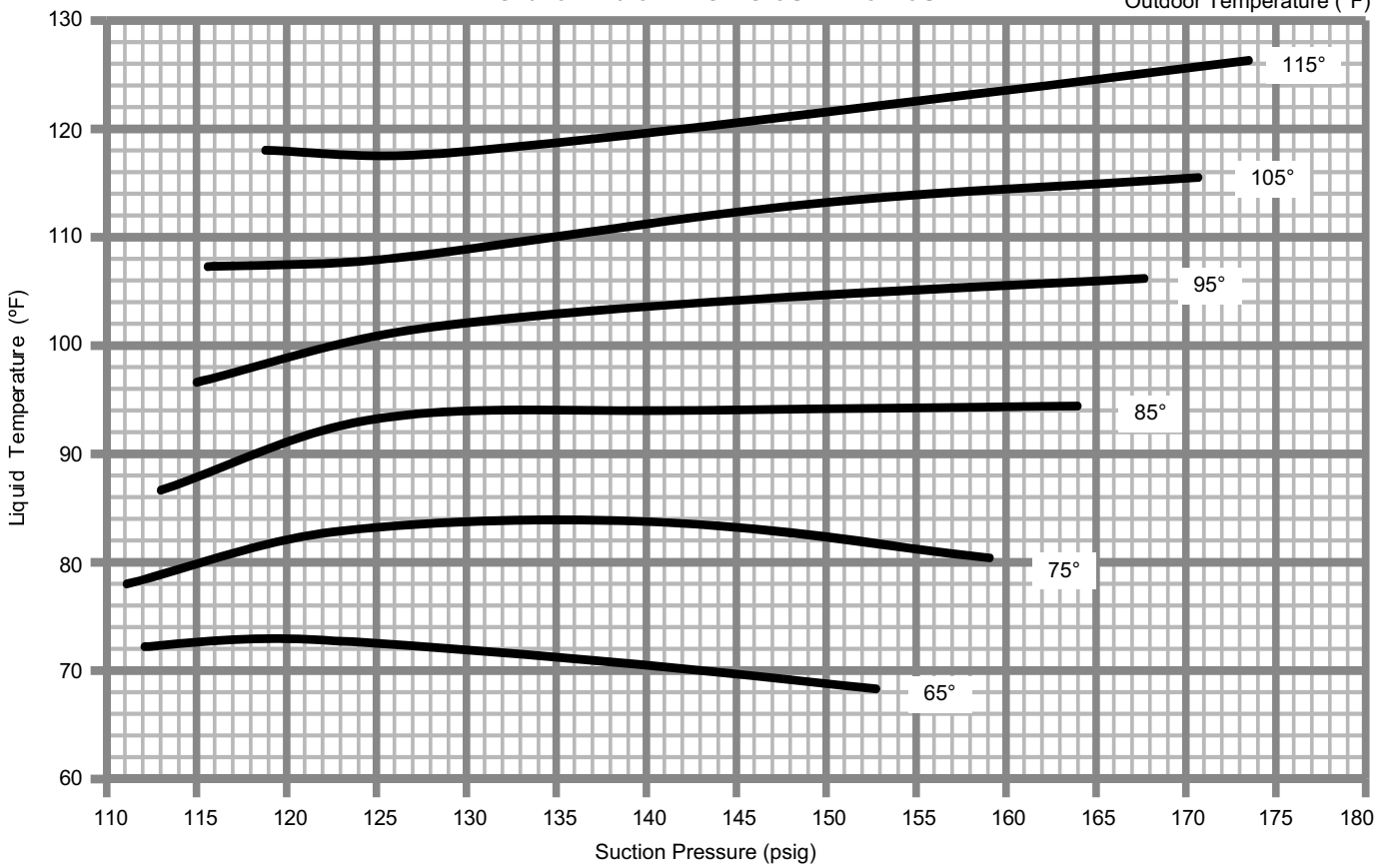
### LGH/LCH210 CHARGING CURVE CIRCUIT 1

Outdoor Temperature (°F)



### LGH/LCH210 CHARGING CURVE CIRCUIT 2

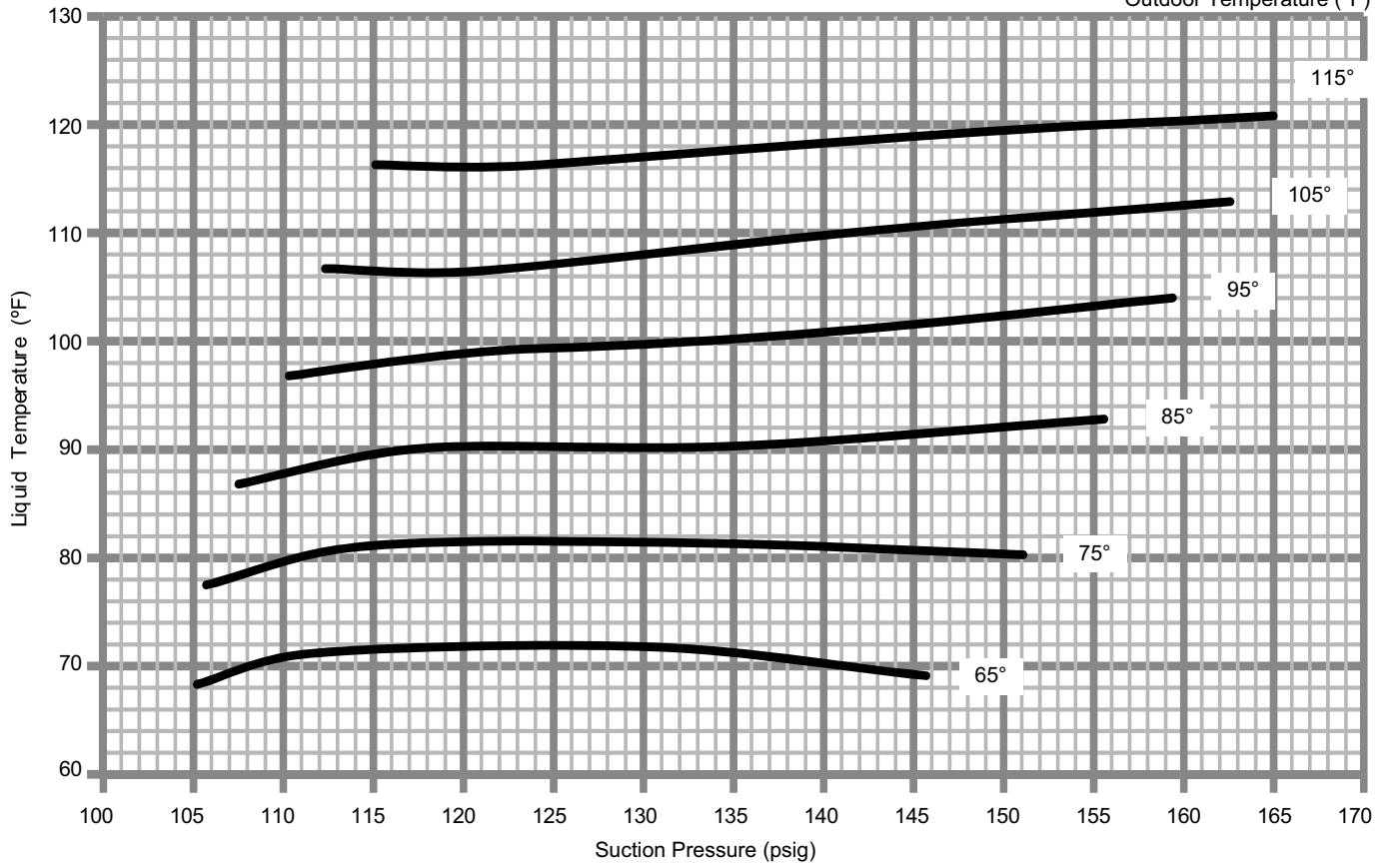
Outdoor Temperature (°F)





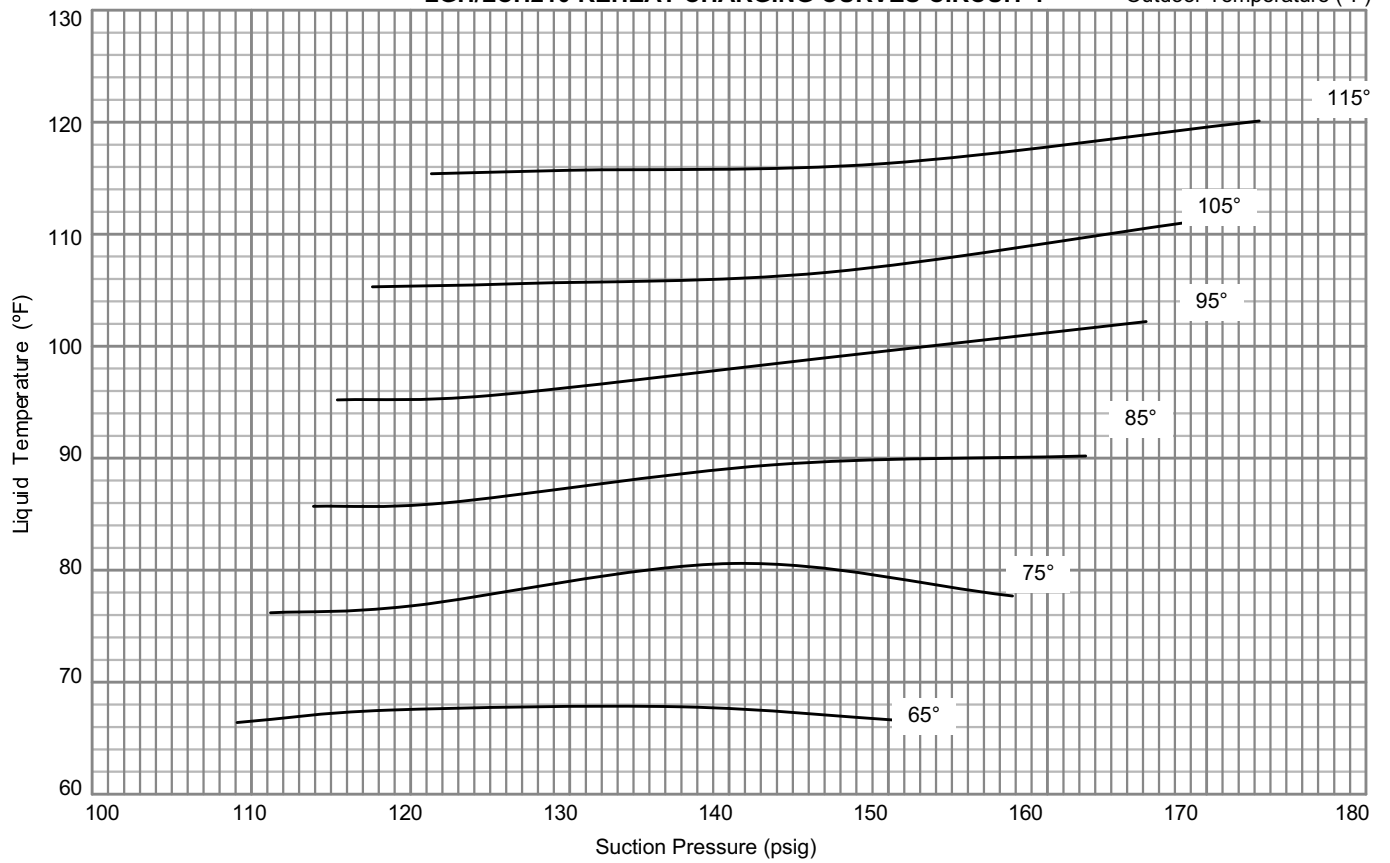
**LGH/LCH210 CHARGING CURVE CIRCUIT 3**

Outdoor Temperature (°F)



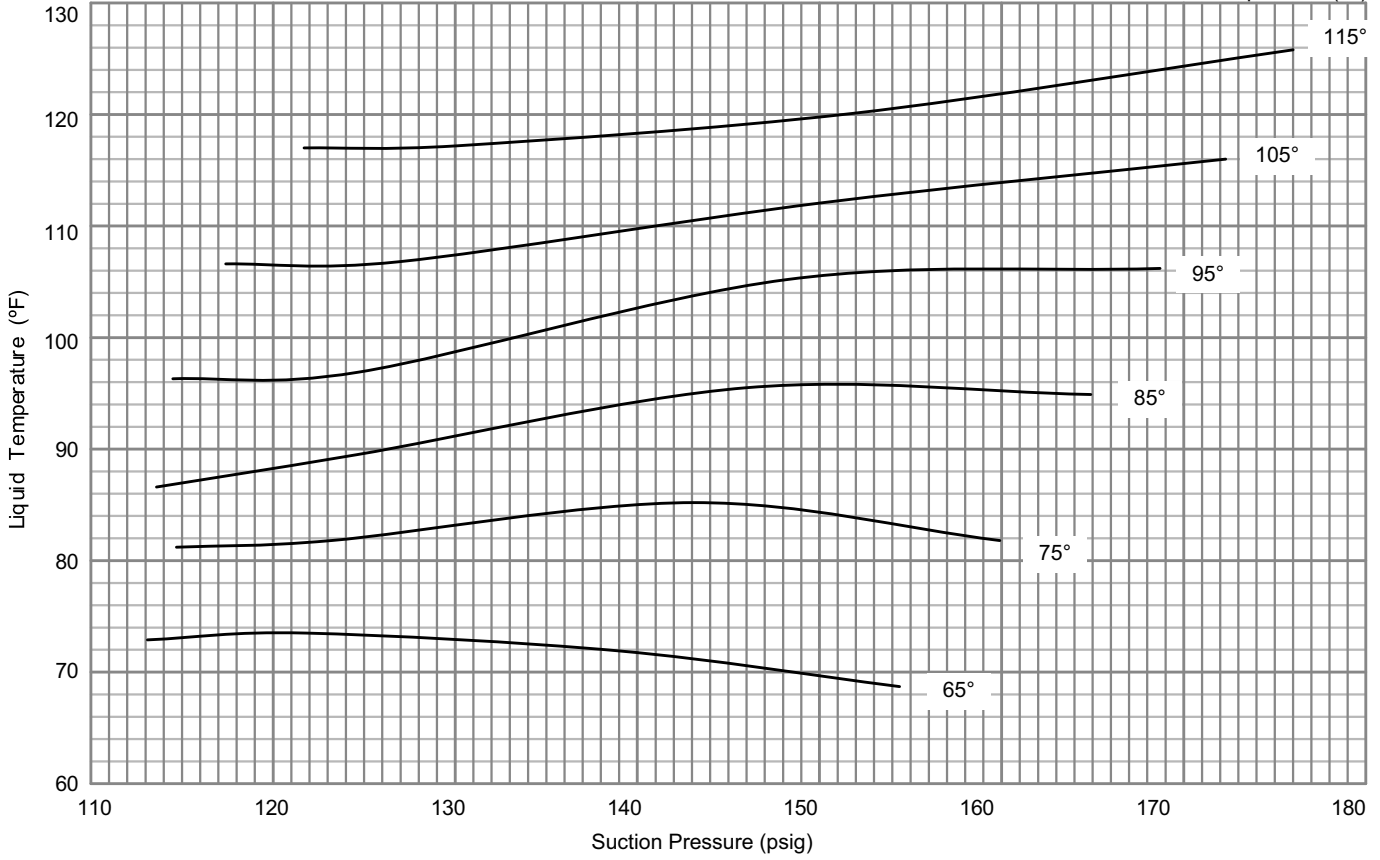
**LGH/LCH210 REHEAT CHARGING CURVES CIRCUIT 1**

Outdoor Temperature (°F)



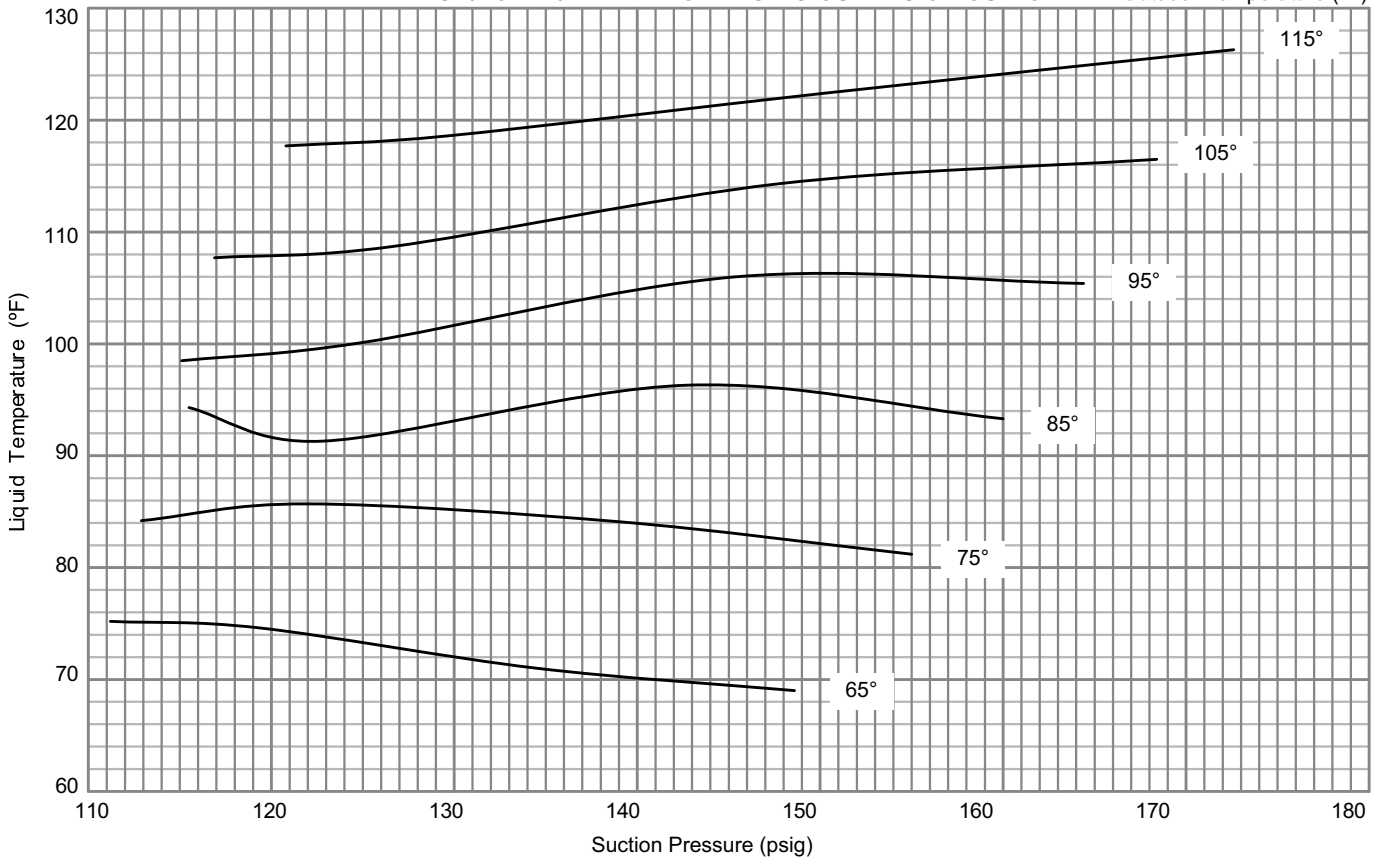
### LGH/LCH210 REHEAT CHARGING CURVES CIRCUIT 2

Outdoor Temperature (°F)



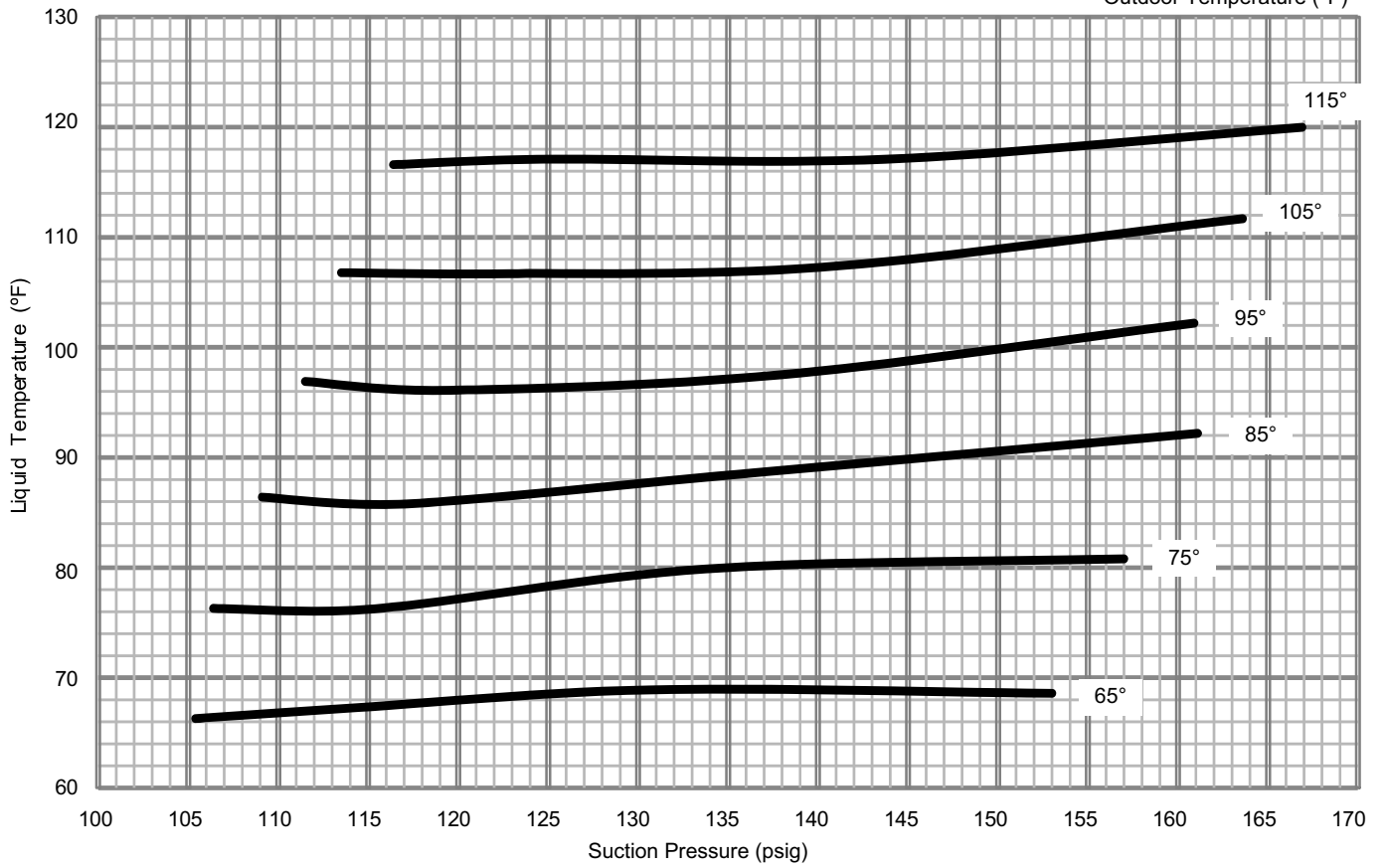
### LGH/LCH210 REHEAT CHARGING CURVES CIRCUIT 3

Outdoor Temperature (°F)



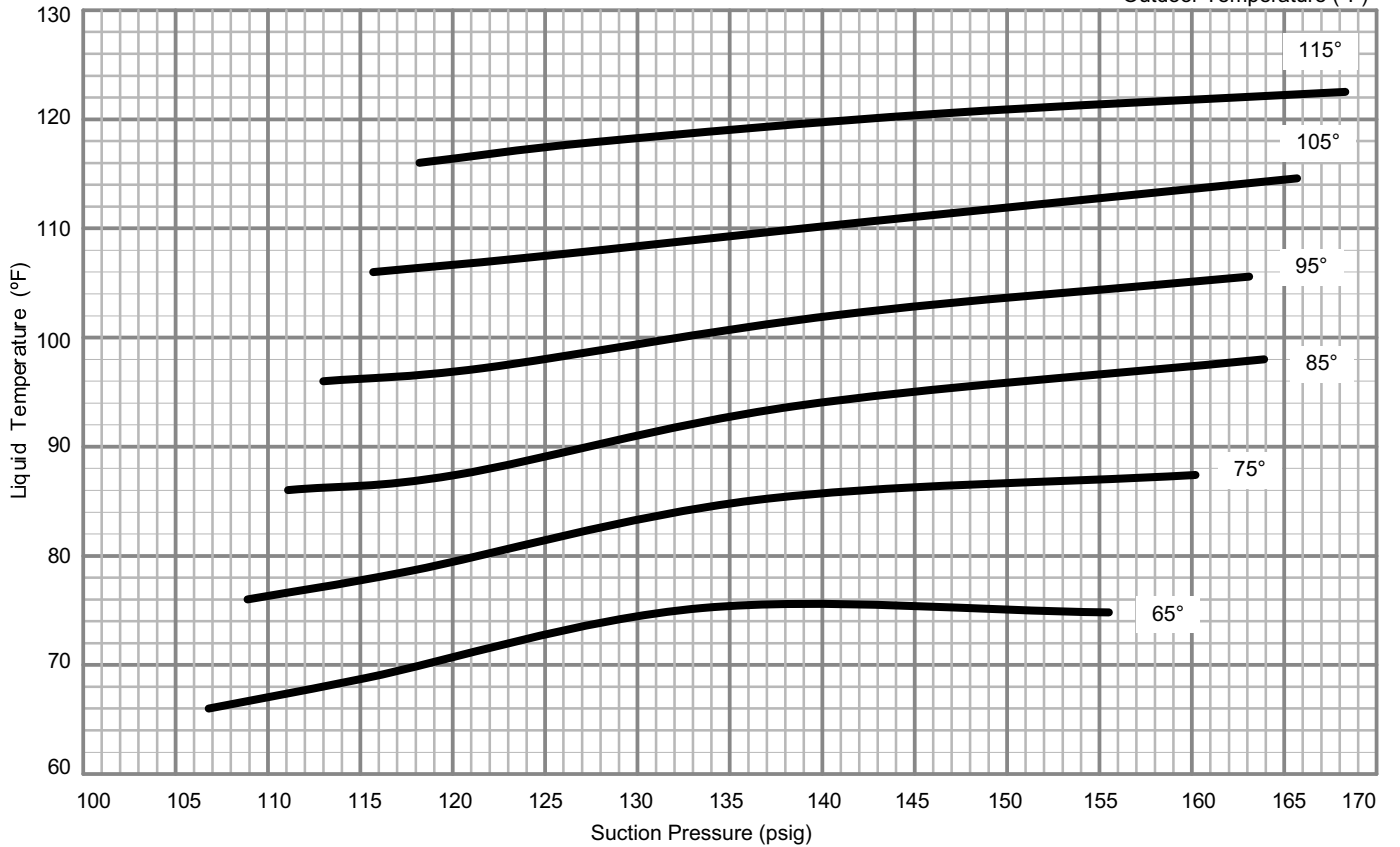
**LGH/LCH240 CAV/STAGED CHARGING CURVES CIRCUIT 1**

Outdoor Temperature (°F)

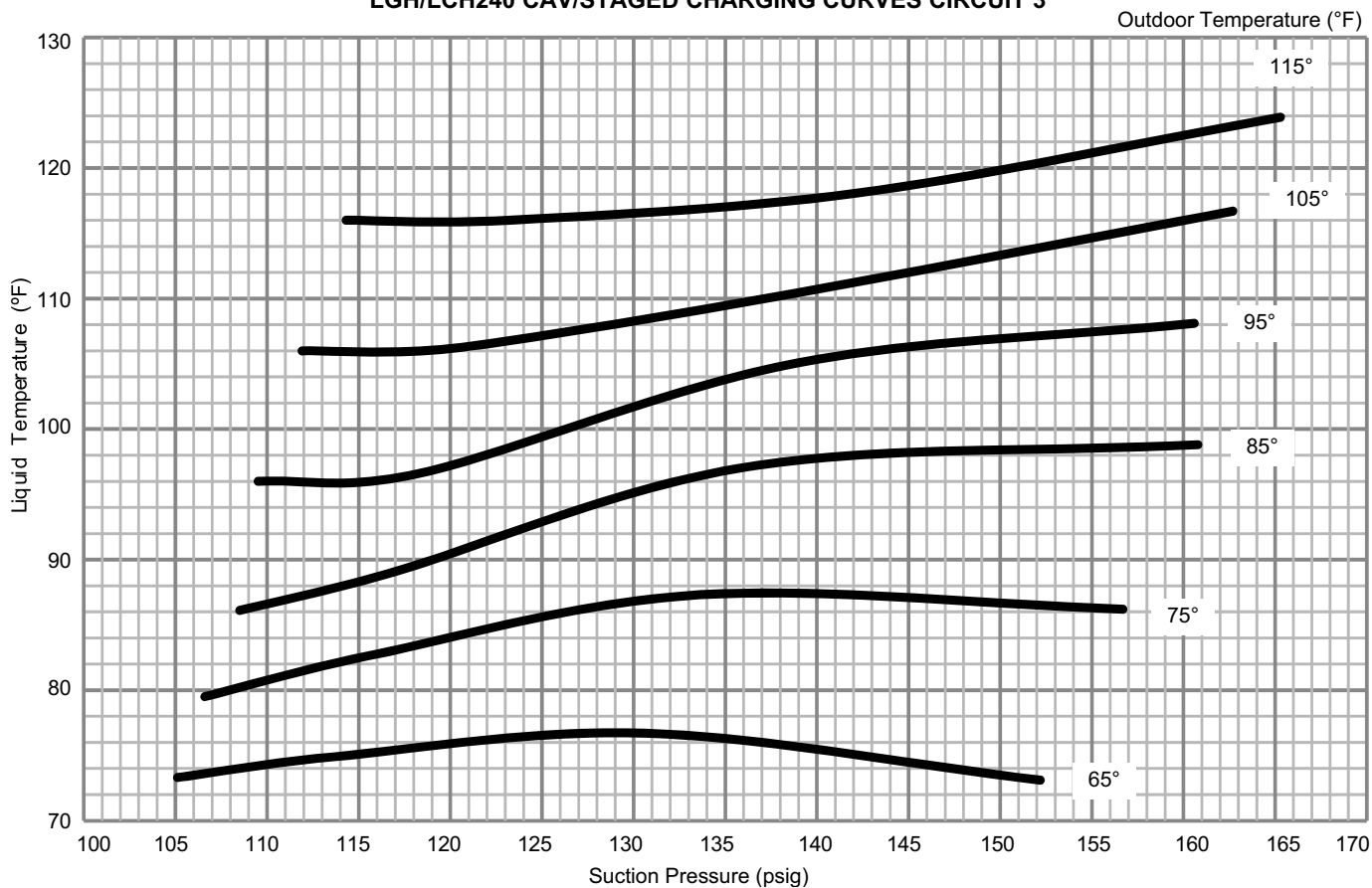


**LGH/LCH240 CAV/STAGED CHARGING CURVES CIRCUIT 2**

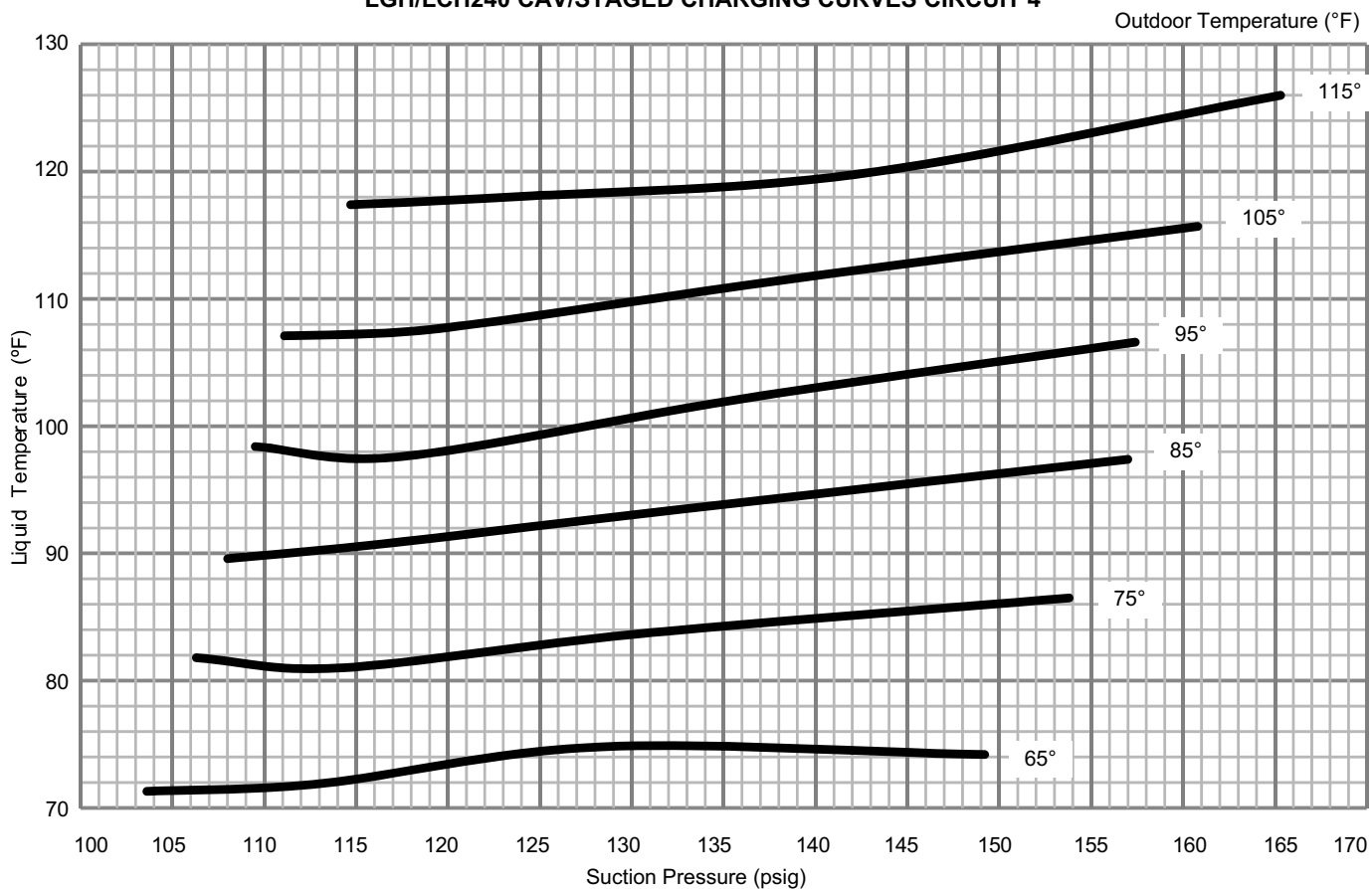
Outdoor Temperature (°F)



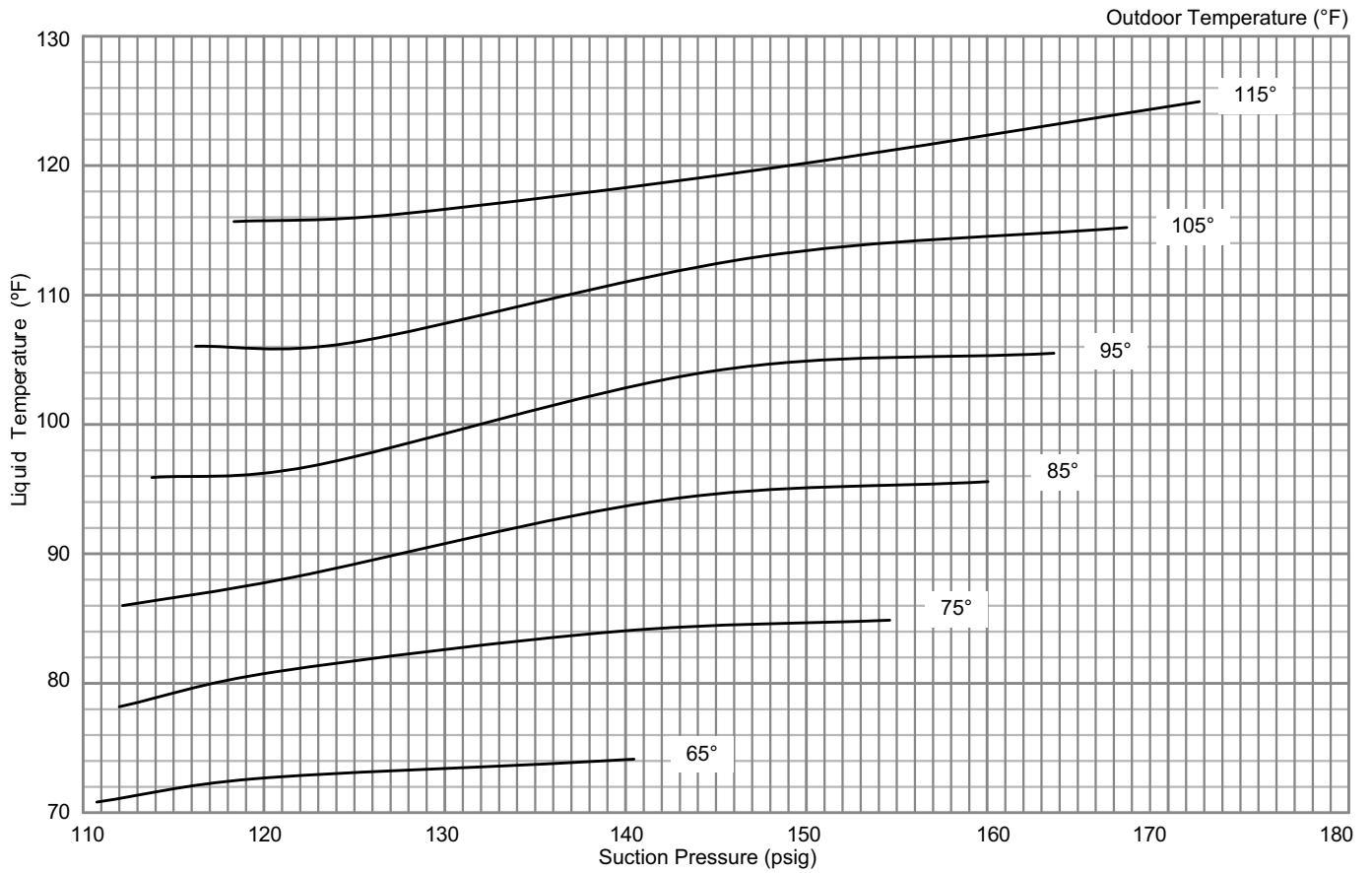
**LGH/LCH240 CAV/STAGED CHARGING CURVES CIRCUIT 3**



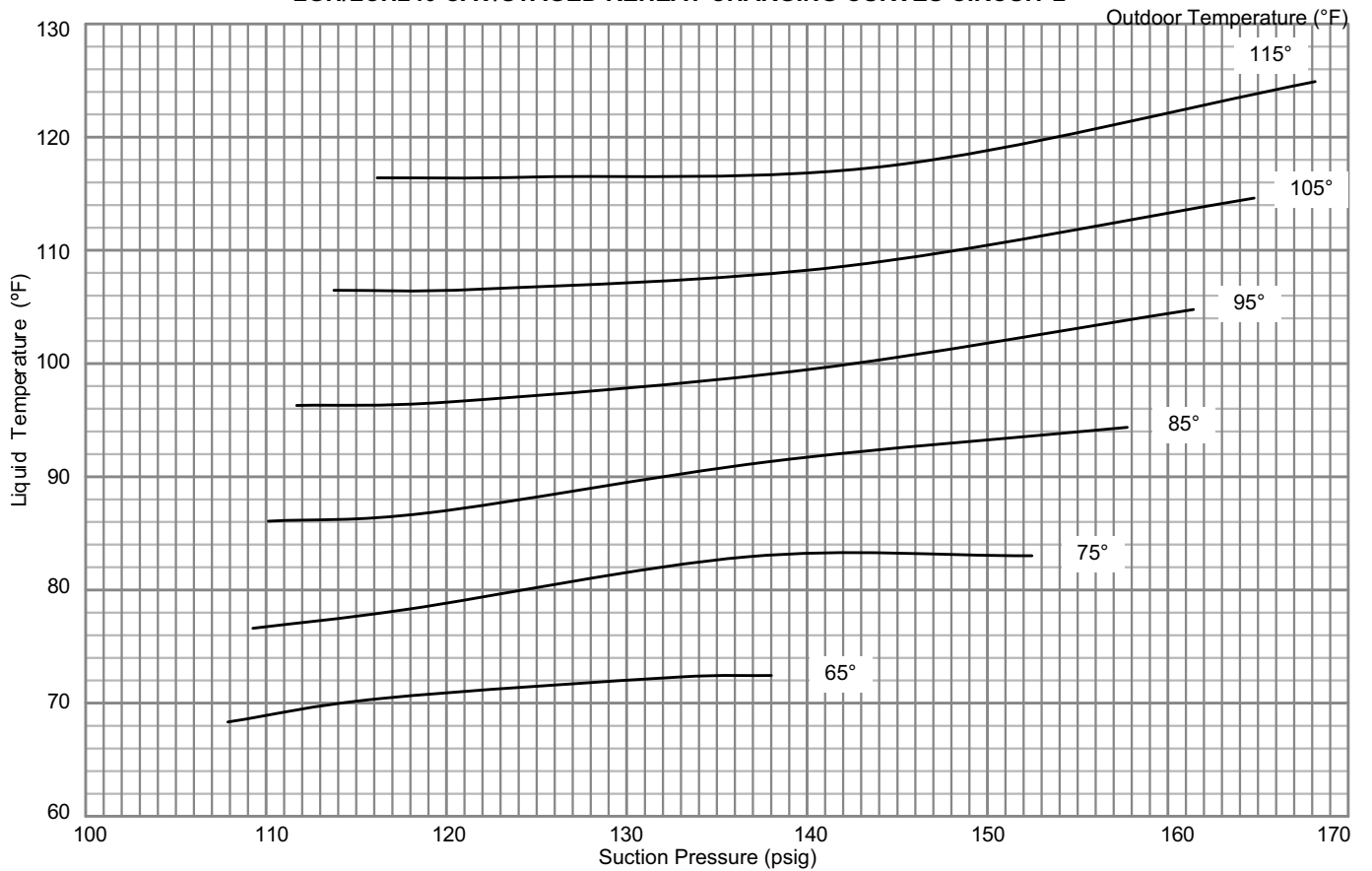
**LGH/LCH240 CAV/STAGED CHARGING CURVES CIRCUIT 4**



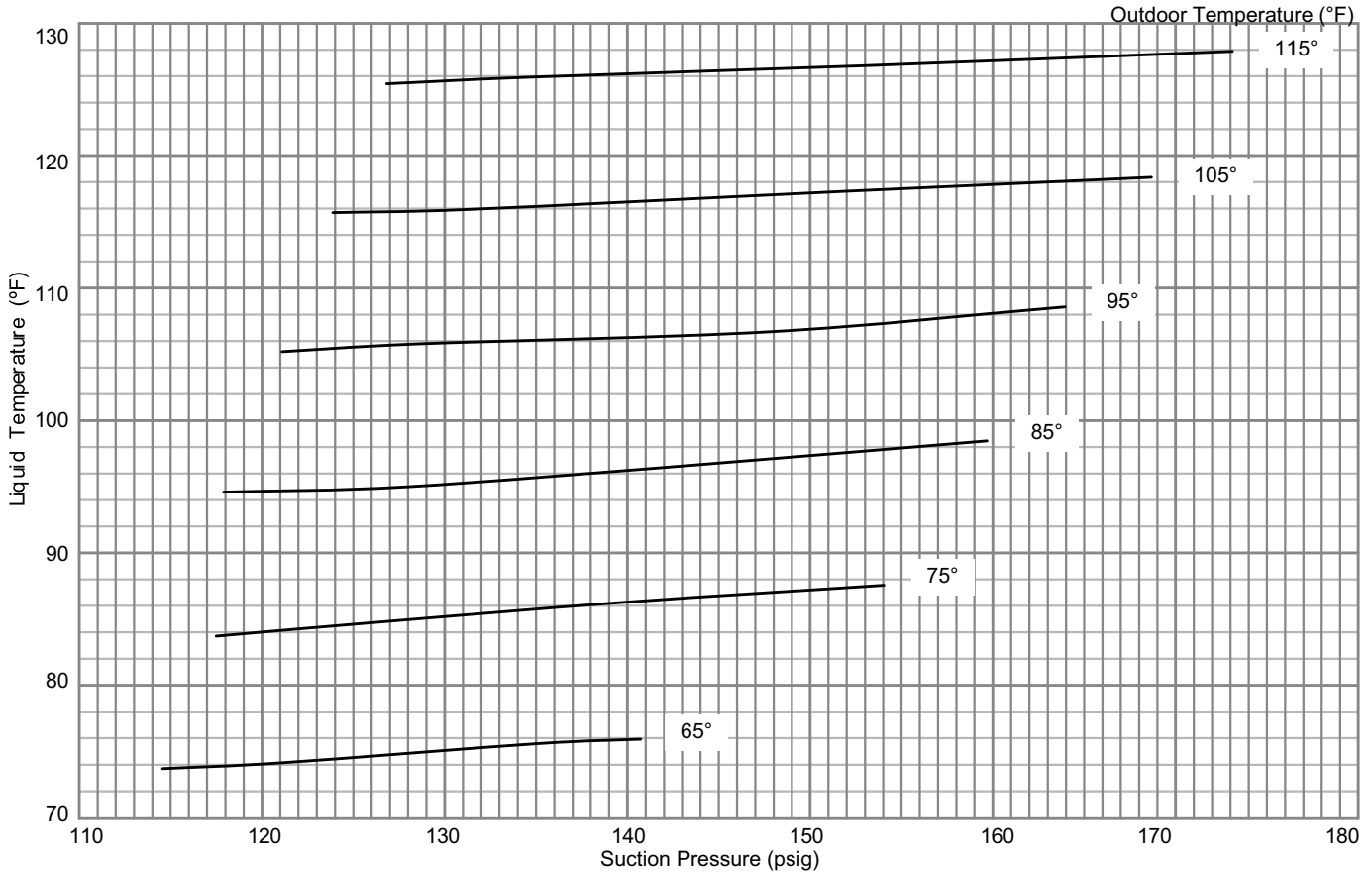
### LGH/LCH240 CAV/STAGED REHEAT CHARGING CURVES CIRCUIT 1



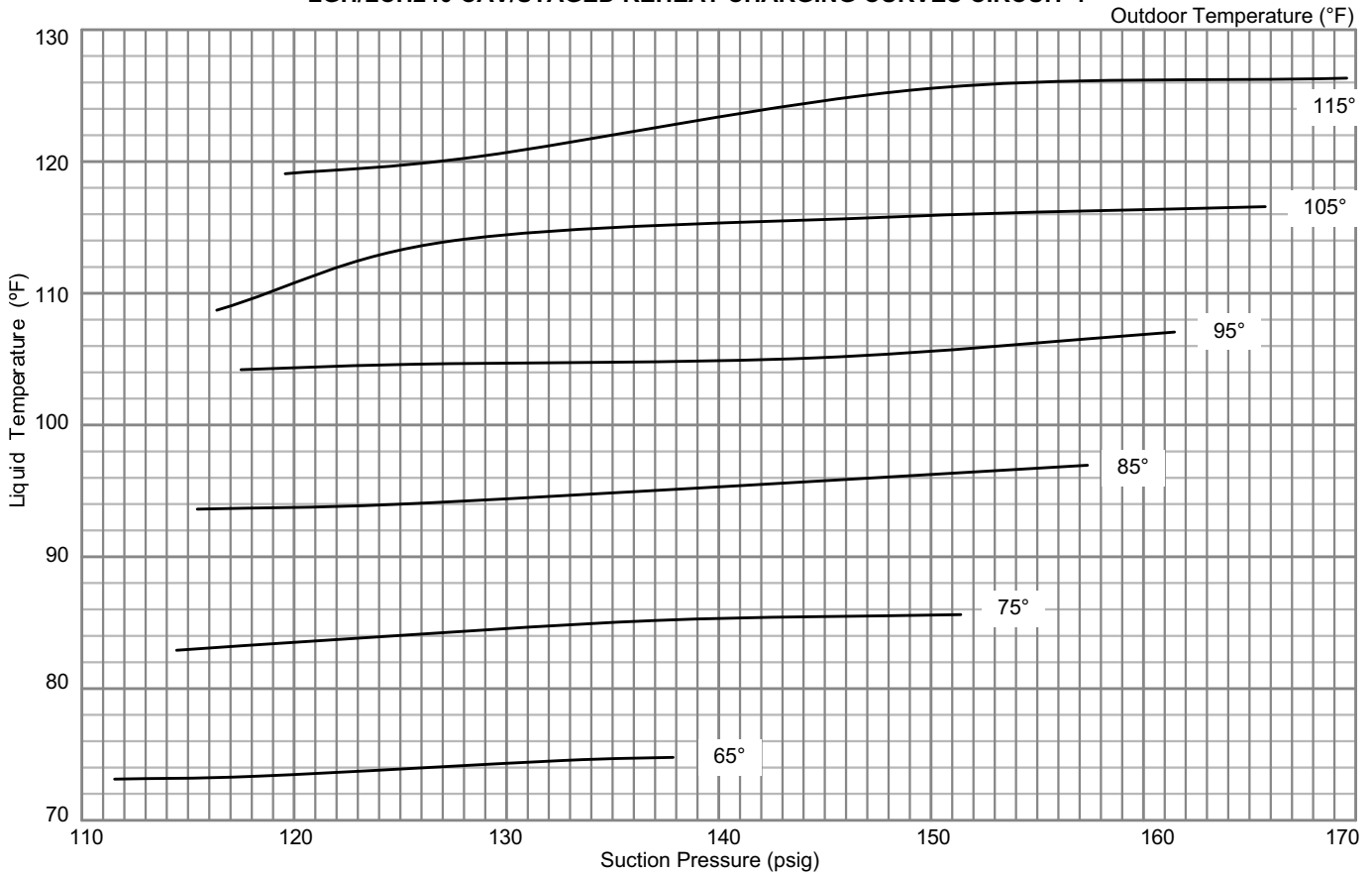
### LGH/LCH240 CAV/STAGED REHEAT CHARGING CURVES CIRCUIT 2



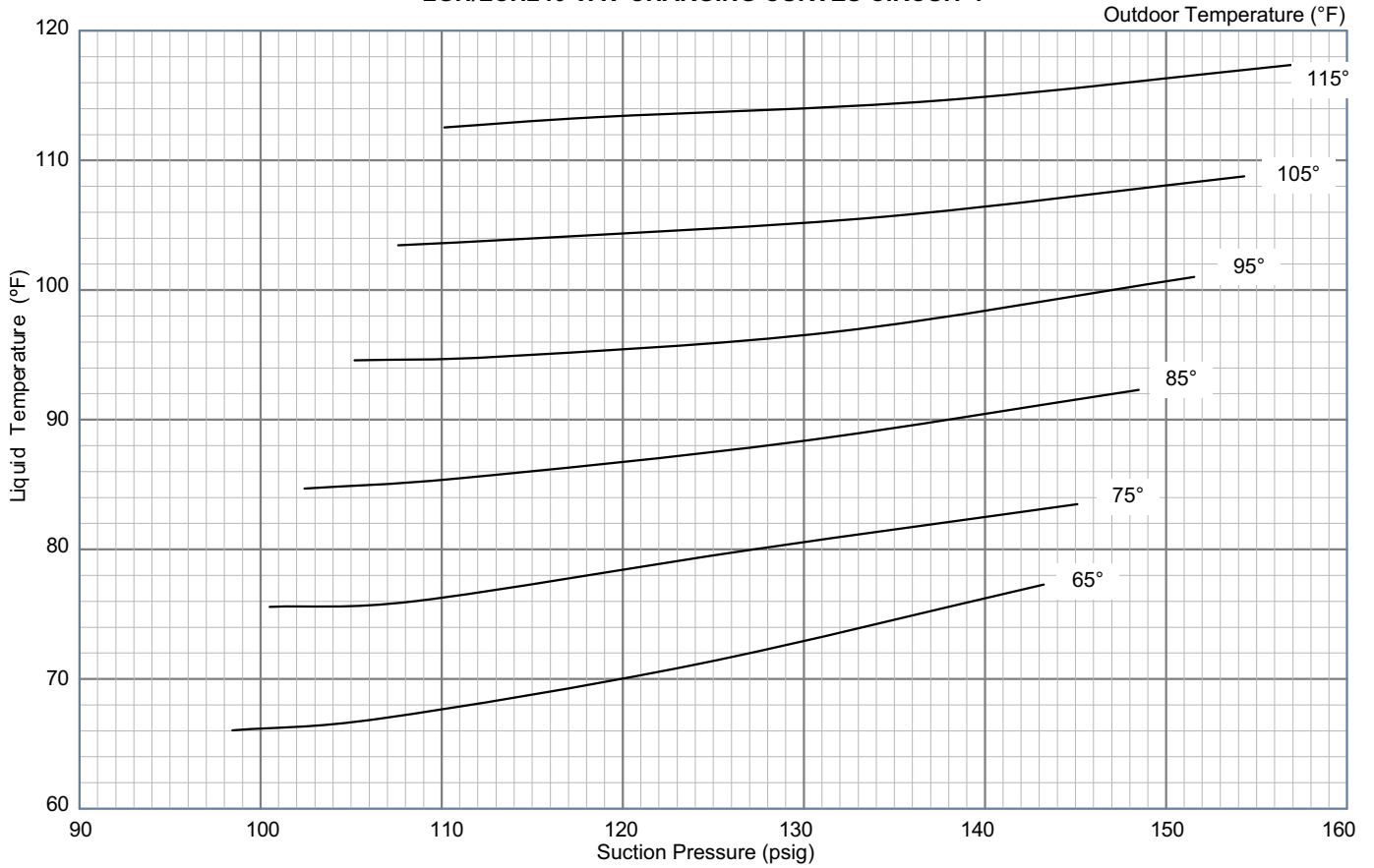
**LGH/LCH240 CAV/STAGED REHEAT CHARGING CURVES CIRCUIT 3**



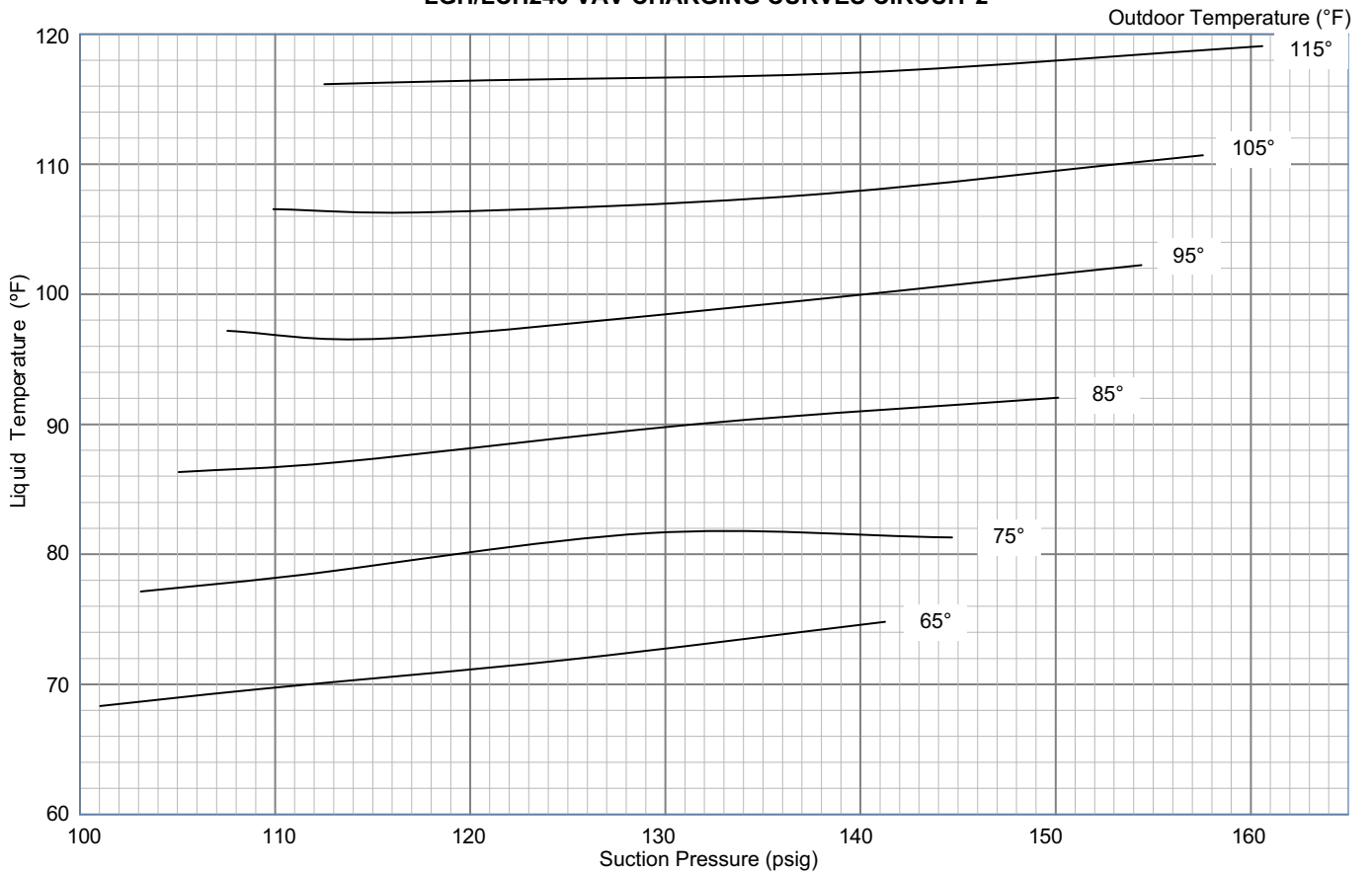
**LGH/LCH240 CAV/STAGED REHEAT CHARGING CURVES CIRCUIT 4**



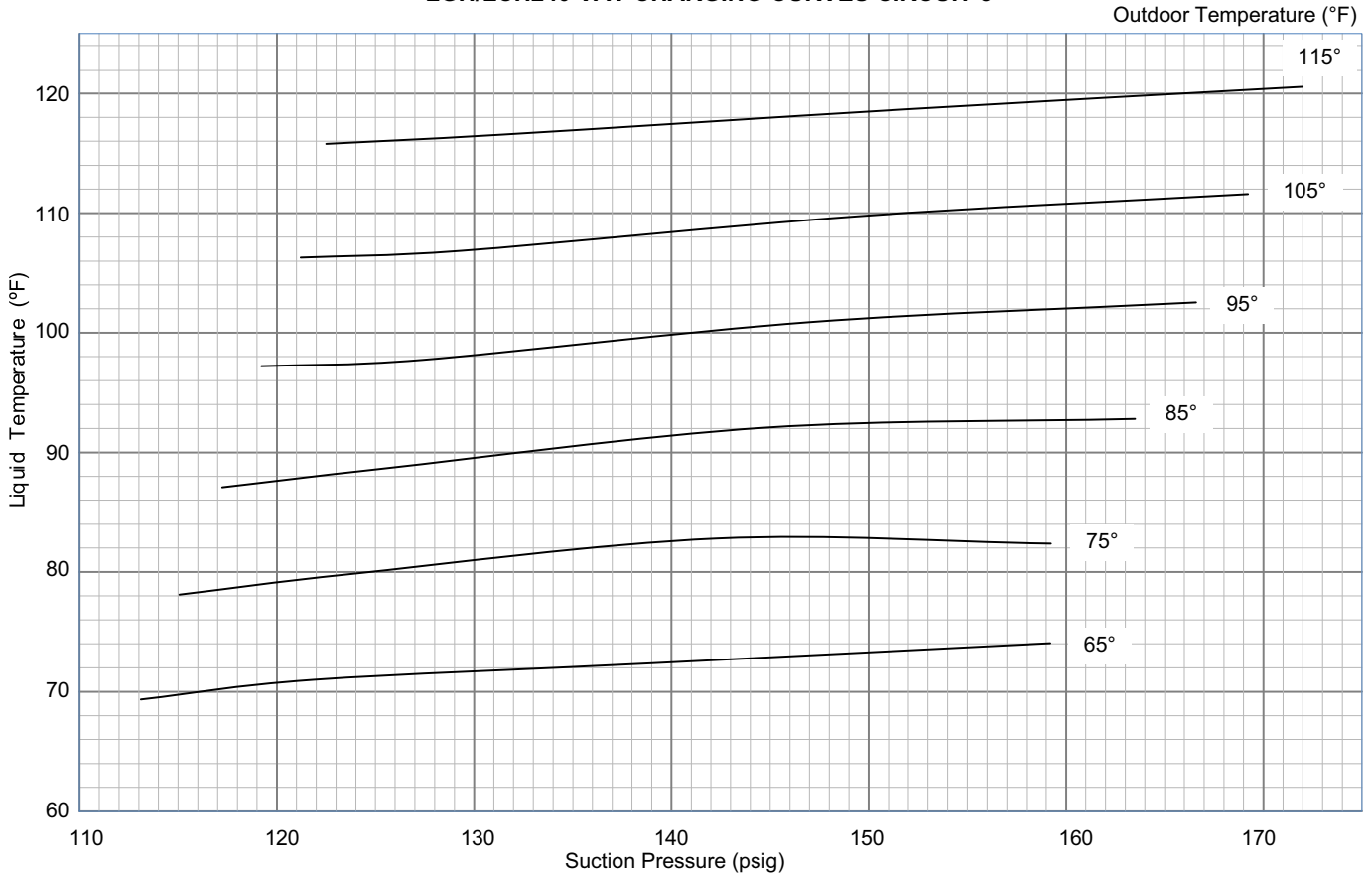
**LGH/LCH240 VAV CHARGING CURVES CIRCUIT 1**



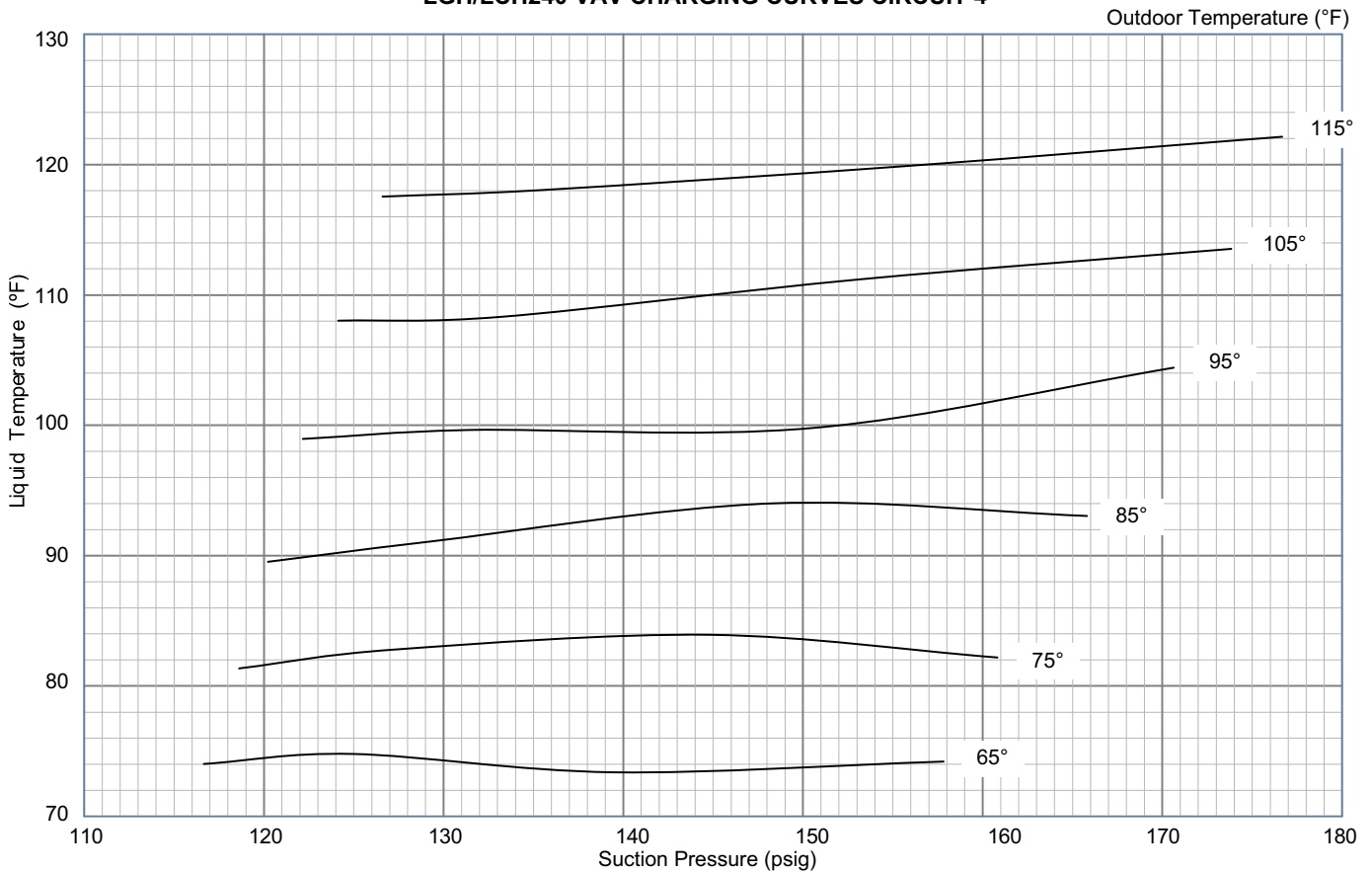
**LGH/LCH240 VAV CHARGING CURVES CIRCUIT 2**



**LGH/LCH240 VAV CHARGING CURVES CIRCUIT 3**



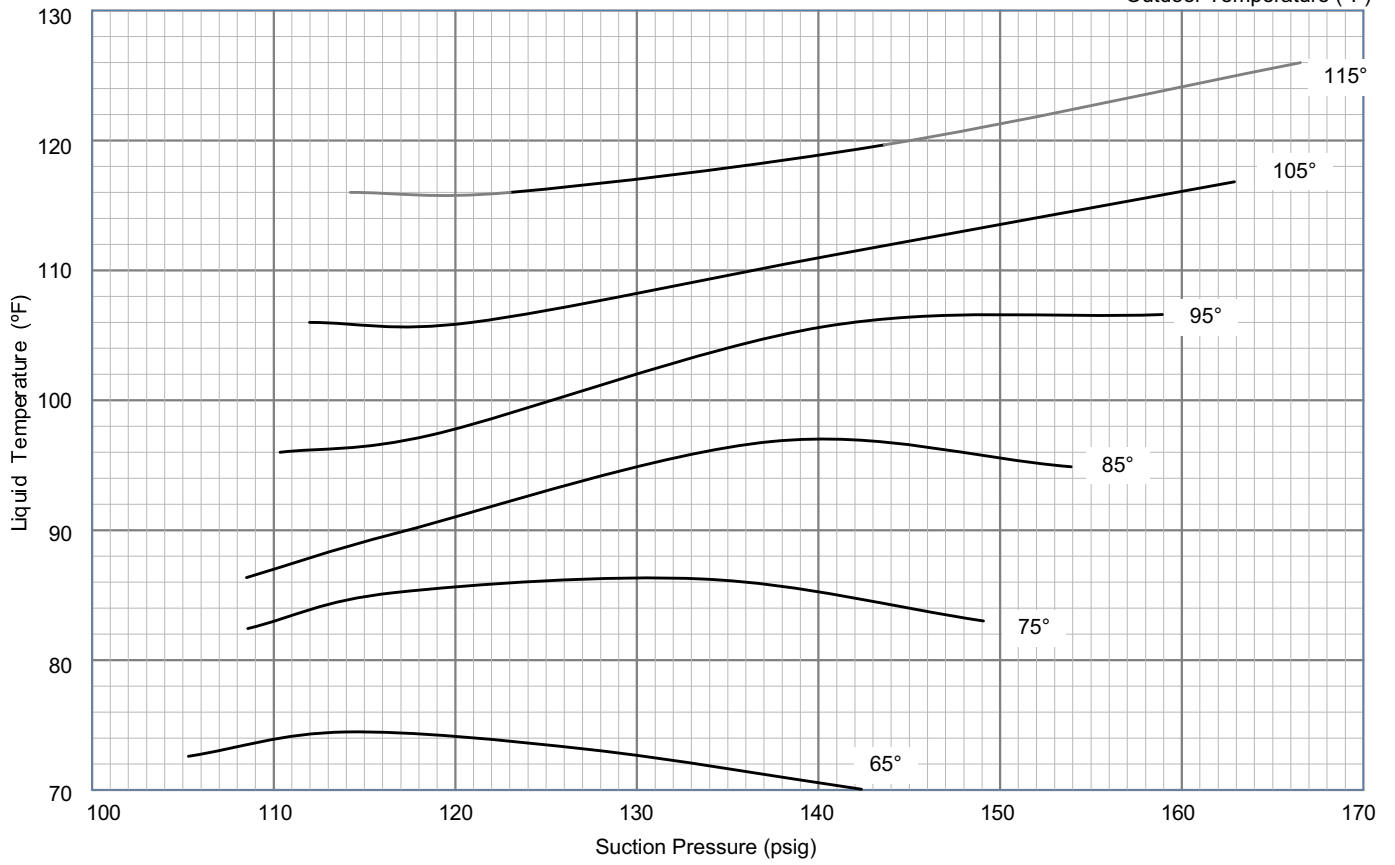
**LGH/LCH240 VAV CHARGING CURVES CIRCUIT 4**





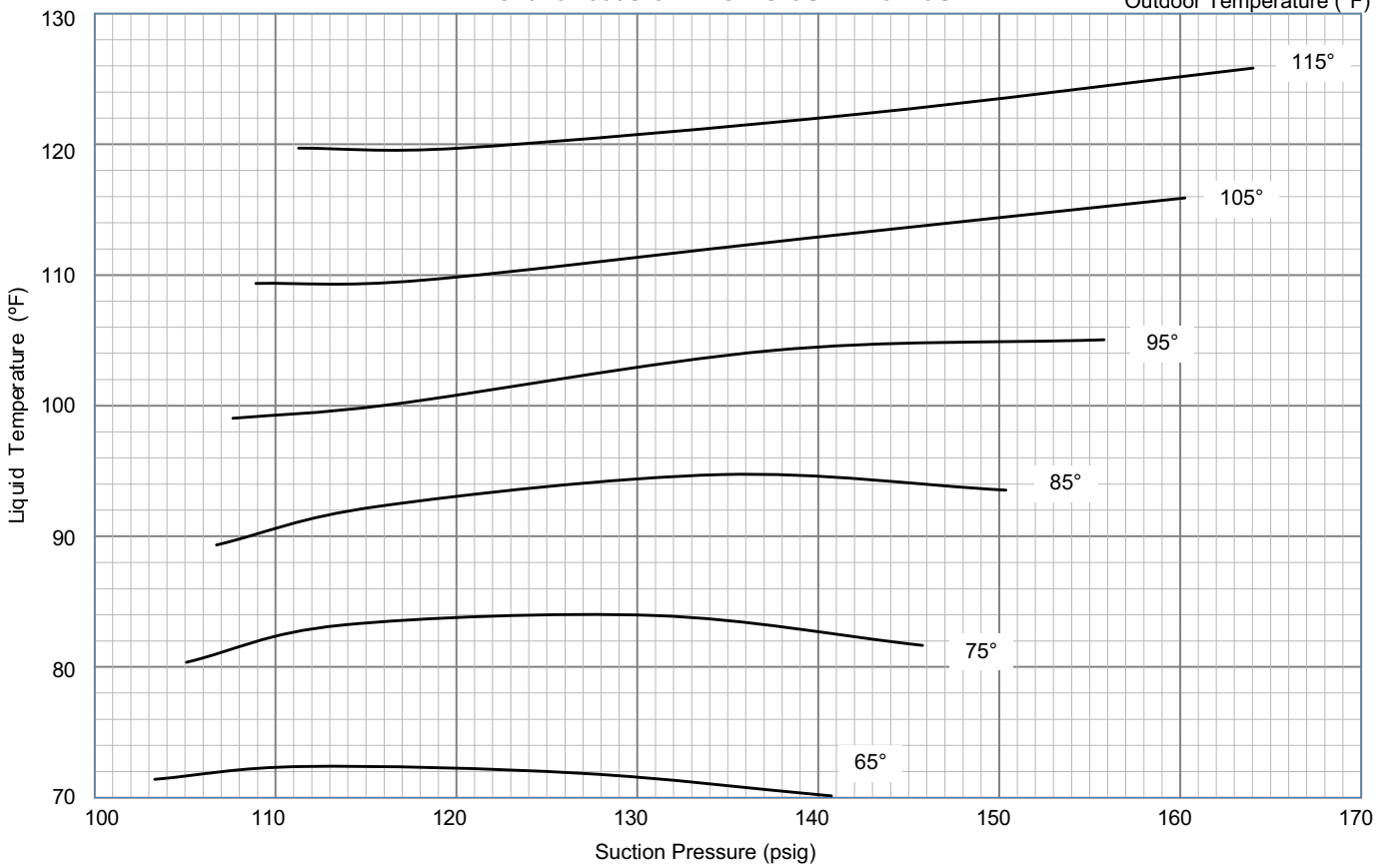
### LGH/LCH300S CHARGING CURVE CIRCUIT 1

Outdoor Temperature (°F)

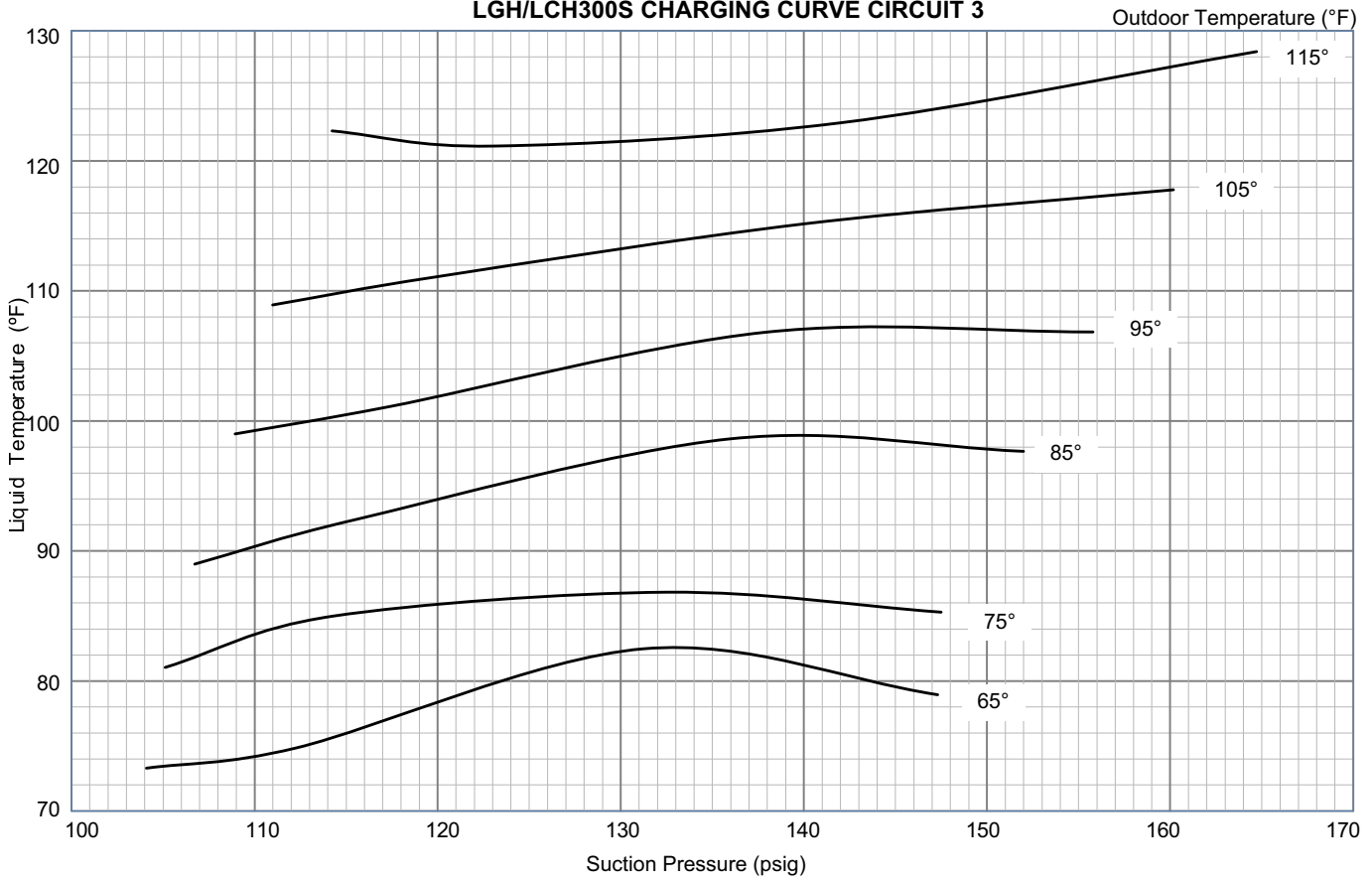


### LGH/LCH300S CHARGING CURVE CIRCUIT 2

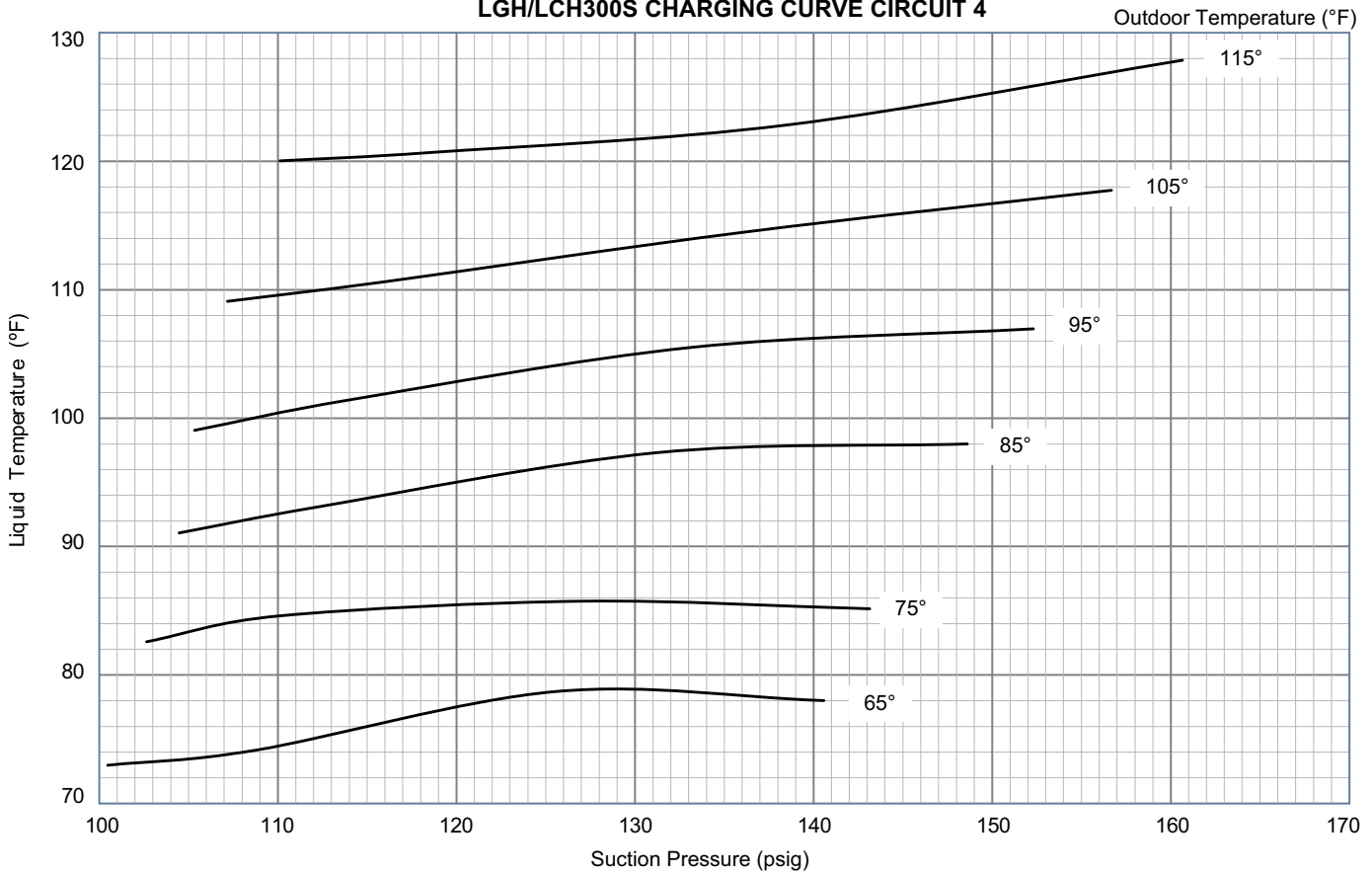
Outdoor Temperature (°F)



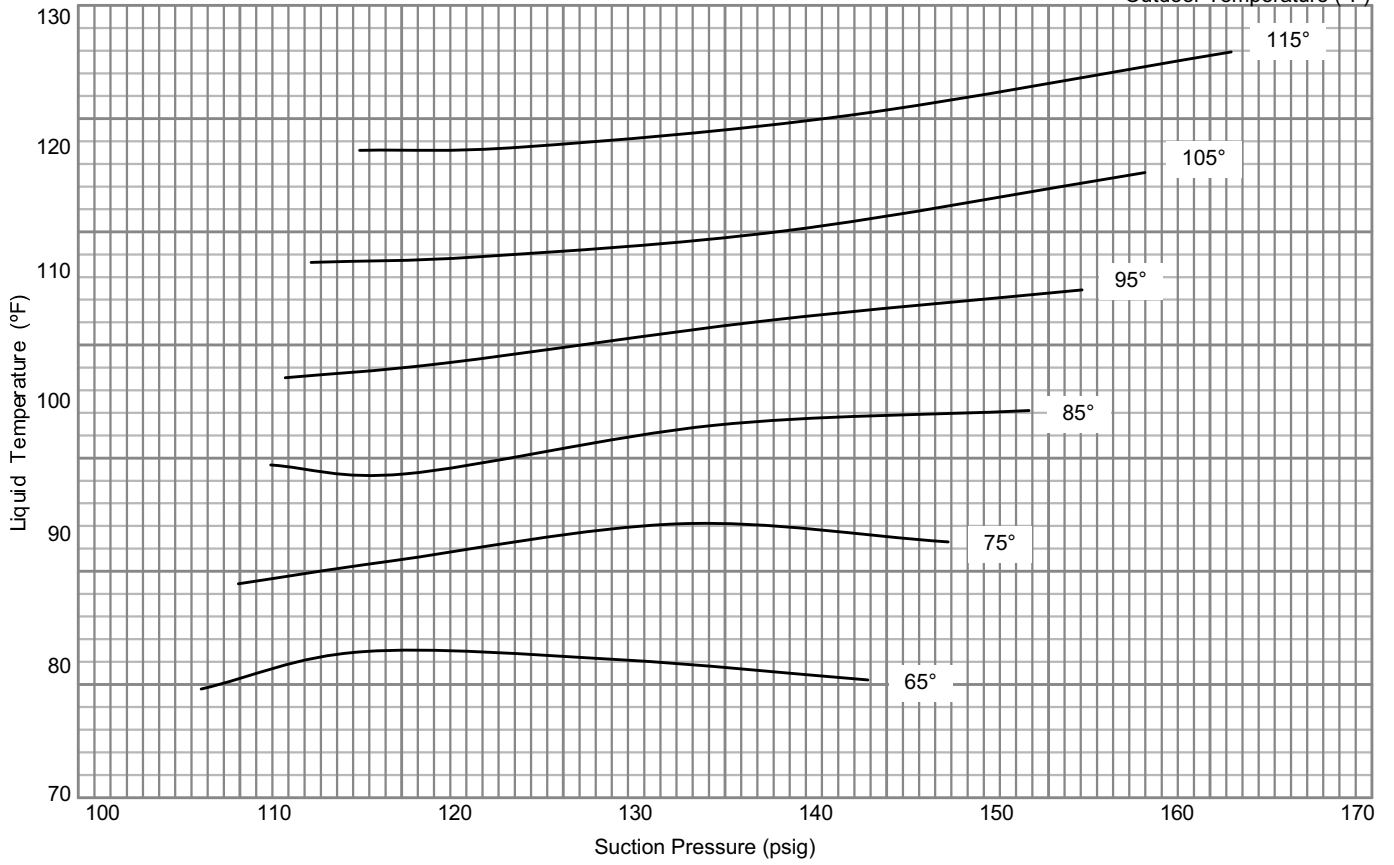
### LGH/LCH300S CHARGING CURVE CIRCUIT 3



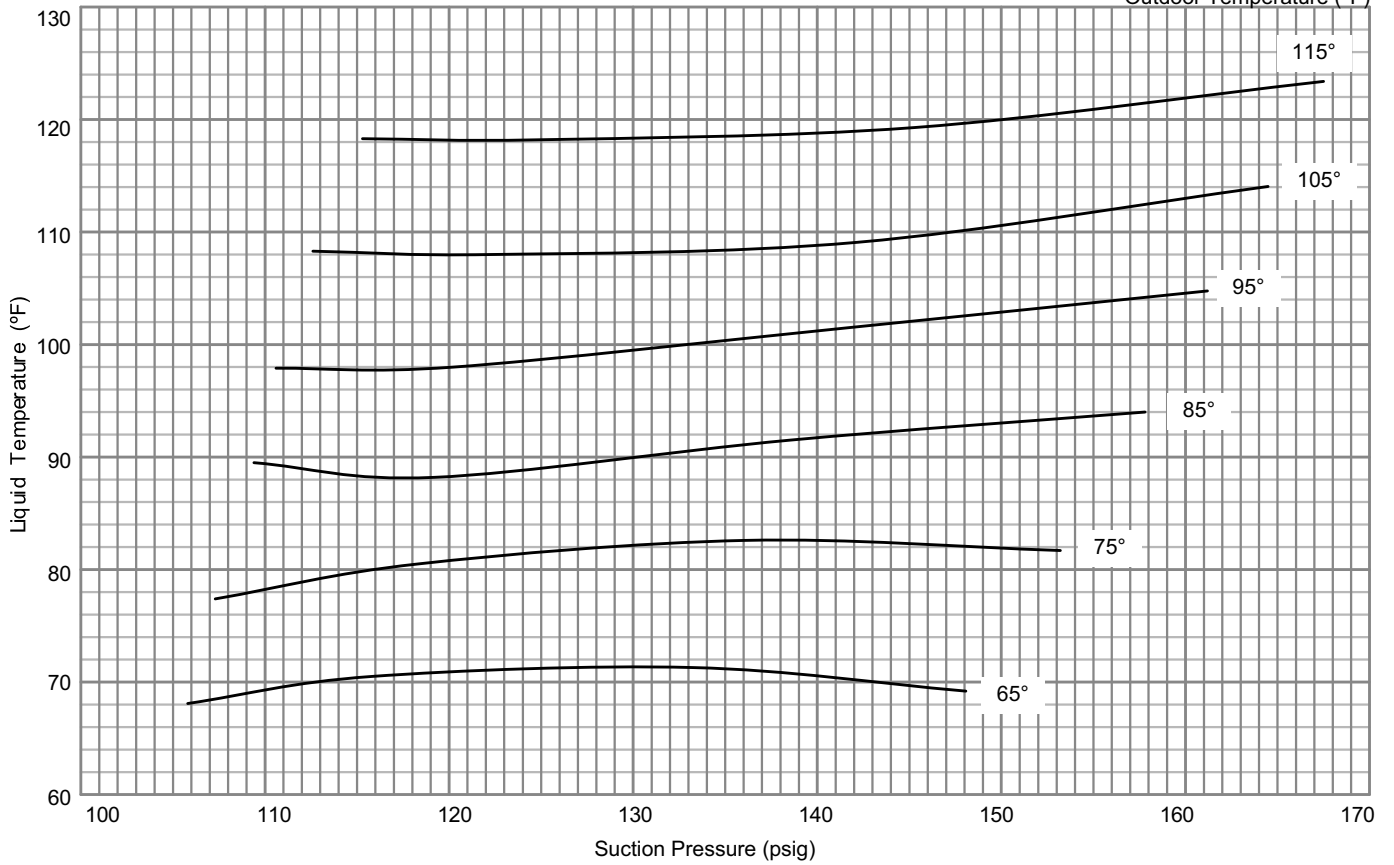
### LGH/LCH300S CHARGING CURVE CIRCUIT 4



**LGH/LCH300S REHEAT CHARGING CURVE CIRCUIT 1** Outdoor Temperature (°F)

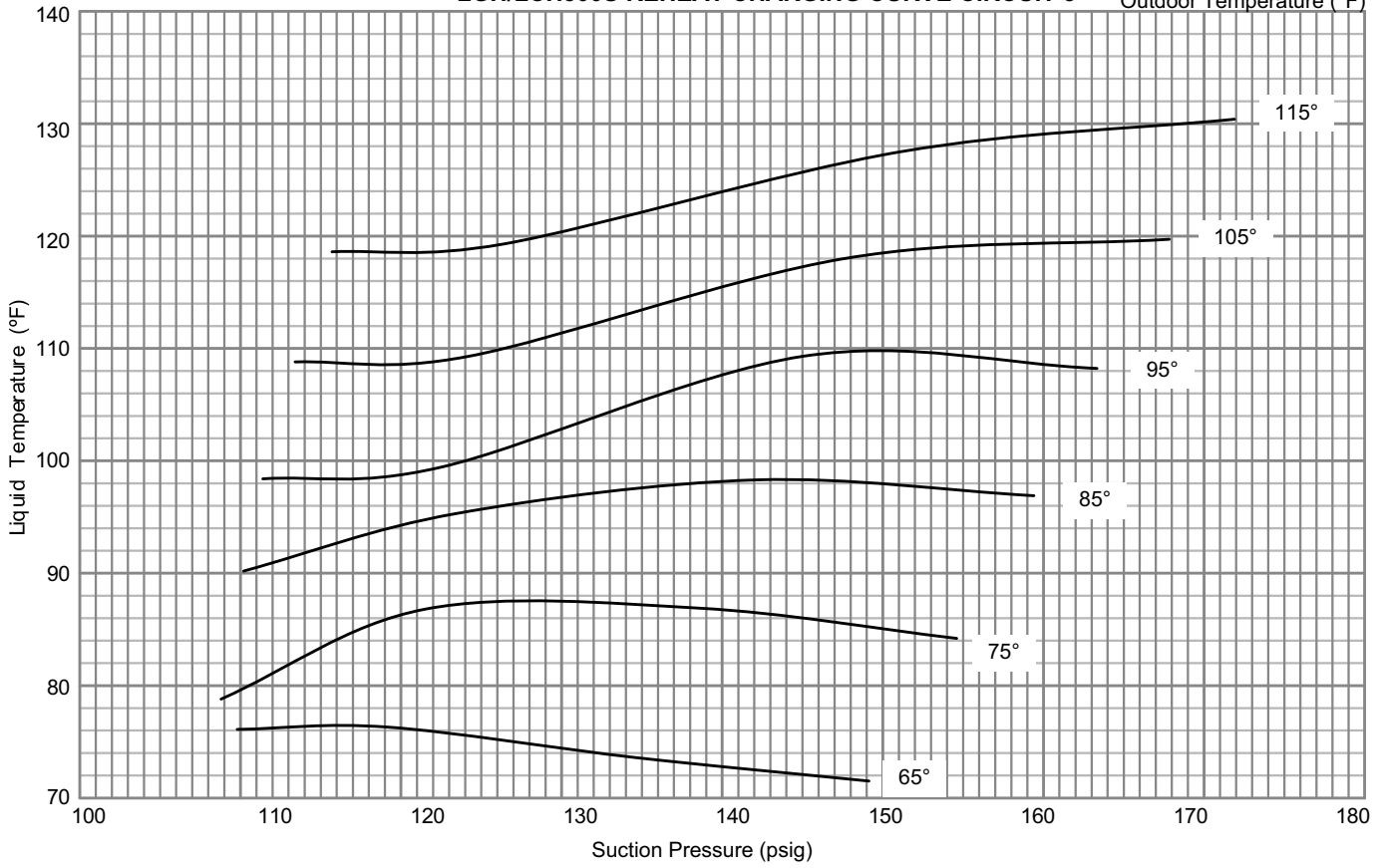


**LGH/LCH300S REHEAT CHARGING CURVE CIRCUIT 2** Outdoor Temperature (°F)



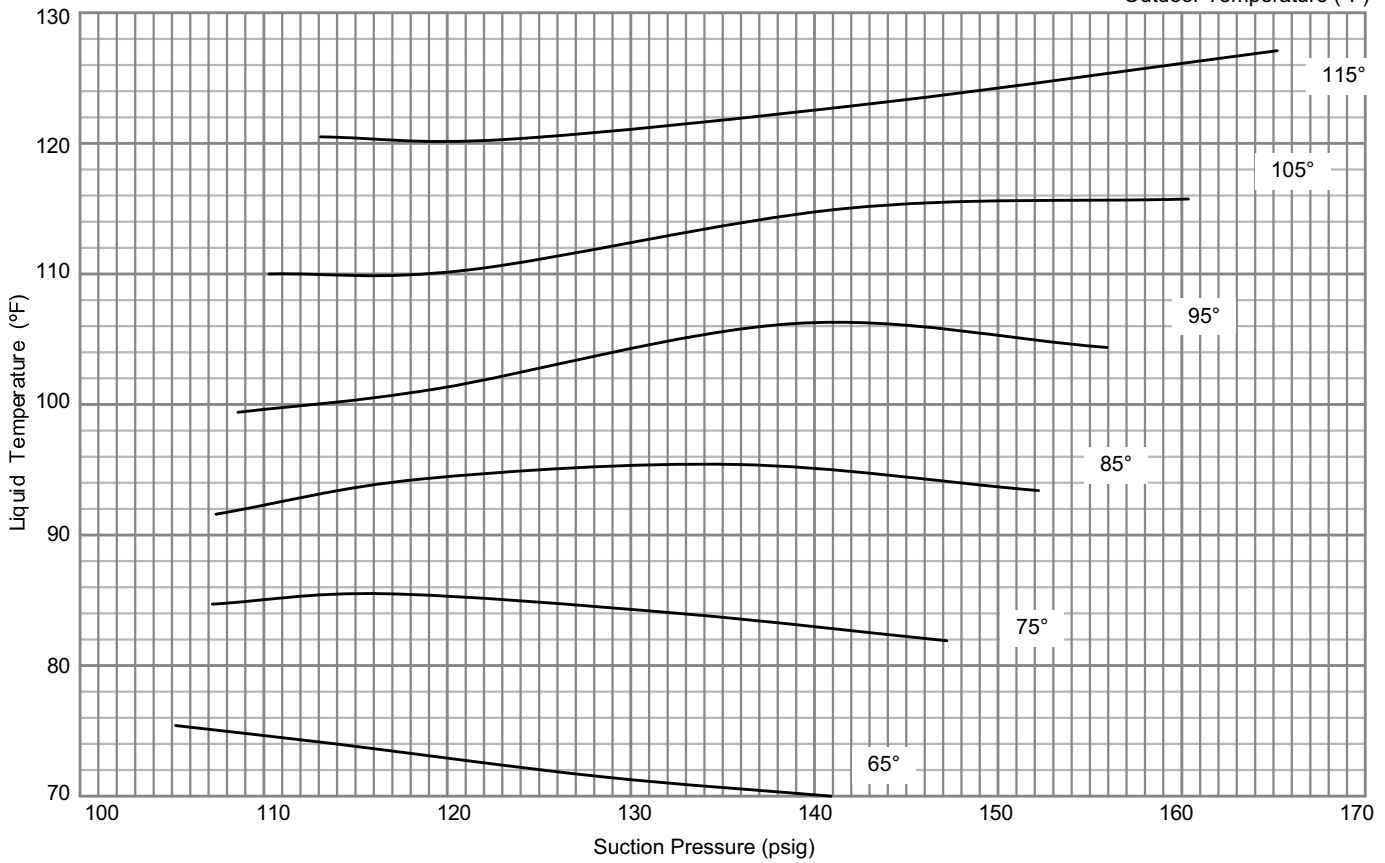
**LGH/LCH300S REHEAT CHARGING CURVE CIRCUIT 3**

Outdoor Temperature (°F)



**LGH/LCH300S REHEAT CHARGING CURVE CIRCUIT 4**

Outdoor Temperature (°F)



## B-Fin/Tube Coil

**WARNING-Do not exceed nameplate charge under any condition.** This unit is factory charged and should require no further adjustment. If the system requires additional refrigerant, *reclaim the charge, evacuate the system and add required nameplate charge.*

**NOTE - System charging is not recommended below 60°F (15°C). In temperatures below 60°F (15°C), the charge *must* be weighed into the system.**

If weighing facilities are not available, or to check the charge, use the following procedure:

### IMPORTANT - Charge unit in normal cooling mode.

- 1 Attach gauge manifolds and operate unit in cooling mode with economizer disabled until system stabilizes (approximately five minutes). Make sure all outdoor air dampers are closed.
- 2 Check each system separately with all stages operating.
- 3 Use a thermometer to accurately measure the outdoor ambient temperature.
- 4 Apply the outdoor temperature to tables 22 through 33 to determine normal operating pressures. Pressures are listed for sea level applications at 80°F dry bulb and 67°F wet bulb return air.
- 5 Compare the normal operating pressures to the pressures obtained from the gauges. Minor variations in these pressures may be expected due to differences in installations. Significant differences could mean that the system is not properly charged or that a problem exists with some component in the system. **Correct any system problems before proceeding.**
- 6 If discharge pressure is high, remove refrigerant from the system. If discharge pressure is low, add refrigerant to the system.
  - Add or remove charge in increments.
  - Allow the system to stabilize each time refrigerant is added or removed.
- 7 Use the following approach method along with the normal operating pressures to confirm readings.

**TABLE 22**  
LG/LC Series 156H Std.

Outdoor Coil Entering Air Temp	Circuit 1		Circuit 2		Circuit 3	
	Dis. ±10 psig	Suc. ±5 psig	Dis. ±10 psig	Suc. ±5 psig	Dis. ±10 psig	Suc. ±5 psig
65°F	255	136	263	136	273	140
75°F	292	139	301	139	311	144
85°F	333	141	342	141	353	146
95°F	378	144	387	143	398	148
105°F	431	148	438	145	449	150
115°F	484	150	490	146	502	152

**TABLE 23**  
LG/LC Series 156H Reheat

Outdoor Coil Entering Air Temp	Circuit 1		Circuit 2		Circuit 3	
	Dis. ±10 psig	Suc. ±5 psig	Dis. ±10 psig	Suc. ±5 psig	Dis. ±10 psig	Suc. ±5 psig
65°F	265	134	273	135	273	140
75°F	302	138	311	138	311	144
85°F	343	140	352	140	353	146
95°F	388	143	397	142	398	148
105°F	441	147	448	144	449	150
115°F	494	149	500	145	502	152

**TABLE 24**  
LG/LC Series 180H Std.

Outdoor Coil Entering Air Temp	Circuit 1		Circuit 2		Circuit 3	
	Dis. ±10 psig	Suc. ±5 psig	Dis. ±10 psig	Suc. ±5 psig	Dis. ±10 psig	Suc. ±5 psig
65°F*	248	137	257	135	259	137
75°F	285	139	294	137	296	137
85°F	328	143	336	139	338	140
95°F	374	146	383	141	385	144
105°F	425	148	433	144	435	147
115°F	479	151	488	147	488	151

**TABLE 25**  
LG/LC Series 180H Reheat

Outdoor Coil Entering Air Temp	Circuit 1		Circuit 2		Circuit 3	
	Dis. ±10 psig	Suc. ±5 psig	Dis. ±10 psig	Suc. ±5 psig	Dis. ±10 psig	Suc. ±5 psig
65°F*	258	136	267	133	259	137
75°F	295	138	304	135	296	137
85°F	338	142	346	137	338	140
95°F	384	145	393	139	385	144
105°F	435	147	443	142	435	147
115°F	488	150	498	145	488	151

**TABLE 26**  
LG/LC Series 180U

Outdoor Coil Entering Air Temp	Circuit 1		Circuit 2	
	Dis. ±10 psig	Suc. ±5 psig	Dis. ±10 psig	Suc. ±5 psig
65°F	246	135	256	136
75°F	282	138	293	139
85°F	324	140	336	142
95°F	368	142	387	145
105°F	407	145	421	147
115°F	461	148	475	151

**TABLE 27**  
LG/LC Series 210H Std.

Outdoor Coil Entering Air Temp	Circuit 1		Circuit 2		Circuit 3	
	Dis. $\pm 10$ psig	Suc. $\pm 5$ psig	Dis. $\pm 10$ psig	Suc. $\pm 5$ psig	Dis. $\pm 10$ psig	Suc. $\pm 5$ psig
65°F*	246	138	252	142	264	138
75°F	284	142	294	145	306	140
85°F	326	145	335	147	348	142
95°F	373	148	380	149	393	144
105°F	422	150	430	151	441	145
115°F	472	153	482	154	492	148

**TABLE 28**  
LG/LC Series 210H Reheat

Outdoor Coil Entering Air Temp	Circuit 1		Circuit 2		Circuit 3	
	Dis. $\pm 10$ psig	Suc. $\pm 5$ psig	Dis. $\pm 10$ psig	Suc. $\pm 5$ psig	Dis. $\pm 10$ psig	Suc. $\pm 5$ psig
65°F*	258	136	264	141	264	138
75°F	296	140	306	144	306	140
85°F	338	143	347	146	348	142
95°F	385	146	392	148	393	144
105°F	434	148	442	150	441	145
115°F	484	151	494	153	492	148

**TABLE 29**  
LG/LC Series 240H Std.

Outdoor Coil Entering Air Temp	Circuit 1		Circuit 2		Circuit 3		Circuit 4	
	Dis. $\pm 10$ psig	Suc. $\pm 5$ psig	Dis. $\pm 10$ psig	Suc. $\pm 5$ psig	Dis. $\pm 10$ psig	Suc. $\pm 5$ psig	Dis. $\pm 10$ psig	Suc. $\pm 5$ psig
65°F*	255	137	246	132	260	141	252	135
75°F	291	140	284	137	298	144	290	137
85°F	332	142	325	140	340	146	331	139
95°F	378	145	371	142	385	148	377	141
105°F	428	148	421	145	436	150	428	143
115°F	481	151	473	148	488	153	479	145

**TABLE 30**  
LG/LC Series 240H Reheat

Outdoor Coil Entering Air Temp	Circuit 1		Circuit 2		Circuit 3		Circuit 4	
	Dis. $\pm 10$ psig	Suc. $\pm 5$ psig	Dis. $\pm 10$ psig	Suc. $\pm 5$ psig	Dis. $\pm 10$ psig	Suc. $\pm 5$ psig	Dis. $\pm 10$ psig	Suc. $\pm 5$ psig
65°F*	270	13	261	130	260	141	252	135
75°F	306	137	299	135	298	144	290	137
85°F	347	140	340	137	340	146	331	139
95°F	393	143	386	140	385	148	377	141
105°F	443	145	436	143	436	150	428	143
115°F	496	148	488	145	488	153	479	145

**TABLE 31**  
LG/LC Series 240U

Outdoor Coil Entering Air Temp	Circuit 1		Circuit 2	
	Dis. $\pm 10$ psig	Suc. $\pm 5$ psig	Dis. $\pm 10$ psig	Suc. $\pm 5$ psig
65°F	251	127	262	128
75°F	290	132	303	133
85°F	331	135	347	136
95°F	376	137	394	139
105°F	426	141	443	142
115°F	479	144	495	145

**TABLE 32**  
LG/LC Series 300S Std.

Outdoor Coil Entering Air Temp	Circuit 1		Circuit 2		Circuit 3		Circuit 4	
	Dis. $\pm 10$ psig	Suc. $\pm 5$ psig	Dis. $\pm 10$ psig	Suc. $\pm 5$ psig	Dis. $\pm 10$ psig	Suc. $\pm 5$ psig	Dis. $\pm 10$ psig	Suc. $\pm 5$ psig
65°F	272	129	273	128	280	129	277	127
75°F	311	132	303	131	321	131	317	129
85°F	357	134	349	133	367	133	363	130
95°F	403	137	397	137	418	135	406	134
105°F	451	139	453	140	475	138	471	136
115°F	502	142	506	142	532	144	529	140

**TABLE 33**  
LG/LC Series 300S Reheat

Outdoor Coil Entering Air Temp	Circuit 1		Circuit 2		Circuit 3		Circuit 4	
	Dis. $\pm 10$ psig	Suc. $\pm 5$ psig	Dis. $\pm 10$ psig	Suc. $\pm 5$ psig	Dis. $\pm 10$ psig	Suc. $\pm 5$ psig	Dis. $\pm 10$ psig	Suc. $\pm 5$ psig
65°F	285	128	284	128	280	129	277	127
75°F	324	132	315	130	321	131	317	129
85°F	368	134	358	132	367	133	363	130
95°F	418	136	406	136	418	136	406	135
105°F	466	138	462	138	475	138	471	136
115°F	517	141	515	141	532	144	529	140

**TABLE 34**  
LG/LC Series 300U Std. - 580965-01

Outdoor Coil Entering Air Temp	Circuit 1		Circuit 2	
	Dis. $\pm 10$ psig	Suc. $\pm 5$ psig	Dis. $\pm 10$ psig	Suc. $\pm 5$ psig
65°F	268	119	265	113
75°F	313	128	309	120
85°F	358	135	351	126
95°F	409	140	405	131
105°F	470	143	463	136
115°F	532	151	505	127

**C-Charge Verification - Approach Method - AHRI Testing (Fin/Tube Coil)**

- Using the same thermometer, compare liquid temperature to outdoor ambient temperature.  
Approach Temperature = Liquid temperature (at condenser outlet) minus ambient temperature.
- Approach temperature should match values in table 35. An approach temperature greater than value shown indicates an undercharge. An approach temperature less than value shown indicates an overcharge.

3 The approach method is not valid for grossly over or undercharged systems. Use tables 22 through 33 as a guide for typical operating pressures.

**TABLE 35  
APPROACH TEMPERATURES - FIN/TUBE COIL**

L Series Unit	Liquid Temp. Minus Ambient Temp.			
	1st Stage	2nd Stage	3rd Stage	4th Stage
156H Std.	9°F ± 1 (5.0°C ±0.5)	9°F ± 1 (5.0°C ±0.5)	11°F ± 1 (6.1°C ±0.5)	NA
156H Reheat	6°F±1 (3.3°C±0.5)	6°F±1 (3.3°C±0.5)	11°F±1 (6.1°C±0.5)	NA
180H Std.	6°F ± 1 (3.3°C ±0.5)	6°F ± 1 (3.3°C ±0.5)	6°F ± 1 (3.3°C ±0.5)	NA
180H Reheat	4°F ± 1 (2.2°C ±0.5)	4°F ± 1 (2.2°C ±0.5)	6°F ± 1 (3.3°C ±0.5)	NA
180U	5°F ± 1 (2.8°C ±0.5)	6.5°F ± 1 (3.6°C ±0.5)	NA	NA
210H Std.	6°F ± 1 (3.3°C ±0.5)	6°F ± 1 (3.3°C ±0.5)	7°F ± 1 (3.9°C ±0.5)	NA
210H Reheat	4°F ± 1 (2.2°C ±0.5)	4°F ± 1 (2.2°C ±0.5)	7°F ± 1 (3.9°C ±0.5)	NA
240H Std.	6°F ± 1 (3.3°C ±0.5)	6°F ± 1 (3.3°C ±0.5)	7°F ± 1 (3.9°C ±0.5)	7°F ± 1 (3.9°C ±0.5)
240H Reheat	4°F ± 1 (2.2°C ±0.5)	4°F ± 1 (2.2°C ±0.5)	8°F ± 1 (4.4°C ±0.5)	8°F ± 1 (4.4°C ±0.5)
240U	4°F ± 1 (2.2°C ±0.5)	6.5°F ± 1 (3.6°C ±0.5)	NA	NA
300S Std.	5°F±1 (2.8°C±0.5)	5°F±1 (2.8°C±0.5)	8°F±1 (4.4°C±0.5)	8°F±1 (4.4°C±0.5)
300S Reheat	3°F±1 (1.7°C±0.5)	3°F±1 (1.7°C±0.5)	8°F±1 (4.4°C±0.5)	8°F±1 (4.4°C±0.5)
300U	4°F ± 1 (2.2°C ±0.5)	10°F ± 1 (5.5°C ±0.5)	NA	NA

## IV-STARTUP - OPERATION

Refer to startup directions and to the unit wiring diagram when servicing. See unit nameplate for minimum circuit ampacity and maximum fuse size.

### A-Preliminary and Seasonal Checks

- 1- Make sure the unit is installed in accordance with the installation instructions and applicable codes.
- 2- Inspect all electrical wiring, both field and factory installed for loose connections. Tighten as required. Refer to unit diagram located on inside of unit control box cover.
- 3- Check to ensure that refrigerant lines are in good condition and do not rub against the cabinet or other refrigerant lines.
- 4- Check voltage. Voltage must be within the range listed on the nameplate. If not, consult power company and have the voltage corrected before starting the unit.
- 5- Recheck voltage and amp draw with unit running. If voltage is not within range listed on unit nameplate, stop unit and consult power company. Refer to unit nameplate for maximum rated load amps.
- 6- Inspect and adjust blower belt (see section on Blower Compartment - Blower Belt Adjustment).

## B-Cooling Startup See figures 19 and 20 for circuits

*NOTE-Crankcase heaters must be energized 24 hours before attempting to start compressor. Set thermostat so that there is no demand to prevent compressor from cycling. Apply power to unit.*

- 1- Initiate first and second stage cooling demands according to instructions provided with thermostat.
- 2- First-stage thermostat demand will energize compressors 1 and 2 on all standard and high efficient units. Second-stage thermostat demand will energize compressor 3 on all standard and high efficiency units and compressor 4 on LCH240H/300. First-stage thermostat demand will energize one compressor from each circuit on ultra high efficiency units. Second-stage thermostat demand will energize the remaining two compressors, one in each circuit, on ultra high efficiency units.
- 3- Units contain three or four refrigerant circuits or stages.
- 4- Each refrigerant circuit is separately charged with refrigerant. See unit rating plate for correct amount of charge.

*NOTE - Refer to III-CHARGING for proper method to check refrigerant charge.*

## C-Three Phase Scroll Compressor Voltage Phasing

Three phase scroll compressors must be phased sequentially to ensure correct compressor and blower rotation and operation. Compressor and blower are wired in phase at the factory. Power wires are color-coded as follows: line 1-red, line 2-yellow, line 3-blue.

- 1- Observe suction and discharge pressures and blower rotation on unit start-up.
- 2- Suction pressure must drop, discharge pressure must rise and blower rotation must match rotation marking.

If pressure differential is not observed or blower rotation is not correct:

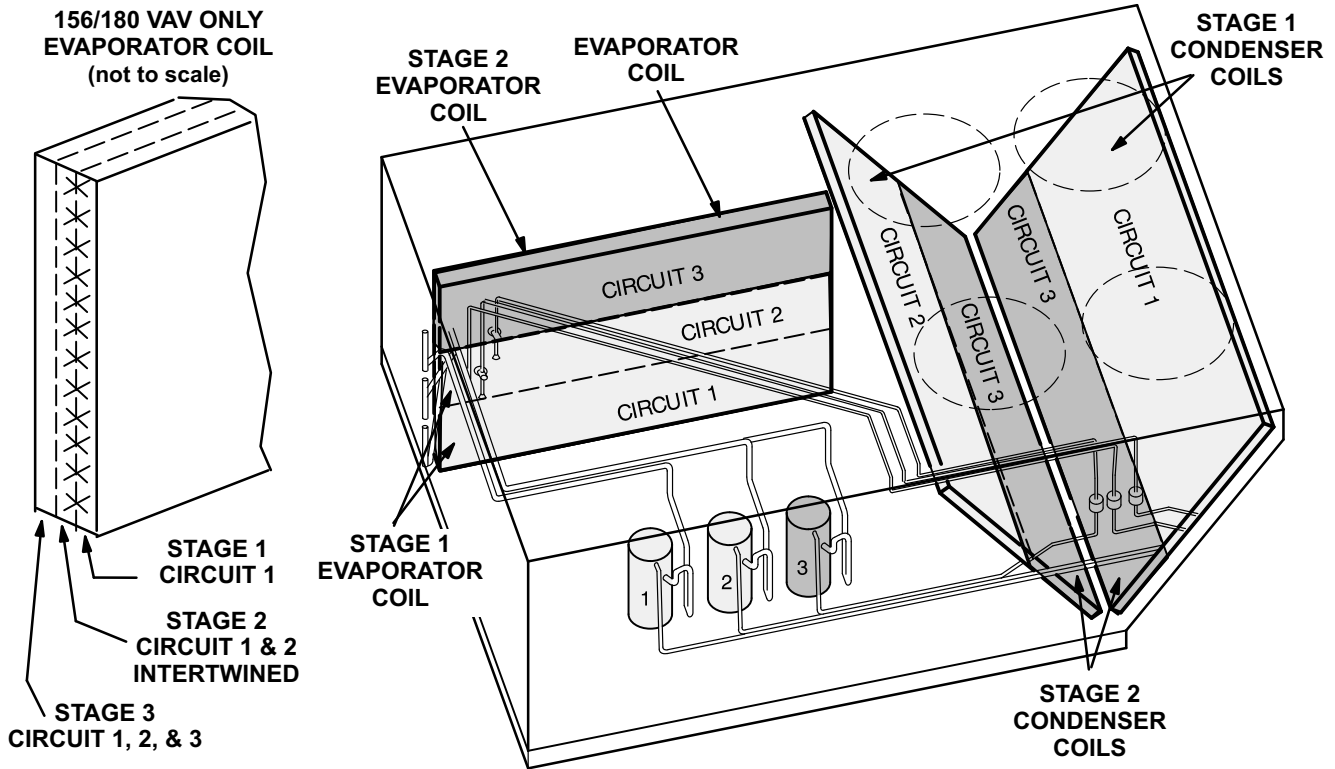
- 3- Disconnect all remote electrical power supplies.
- 4- Reverse any two field-installed wires connected to the line side of S48 disconnect or TB13 terminal strip. Do not reverse wires at blower contactor.
- 5- Make sure the connections are tight.

Discharge and suction pressures should operate at their normal start-up ranges.

## D-Safety or Emergency Shutdown

Turn off power to the unit.

## 156, 180H, & 210 REFRIGERANT CIRCUITS



## 240H & 300S REFRIGERANT CIRCUITS

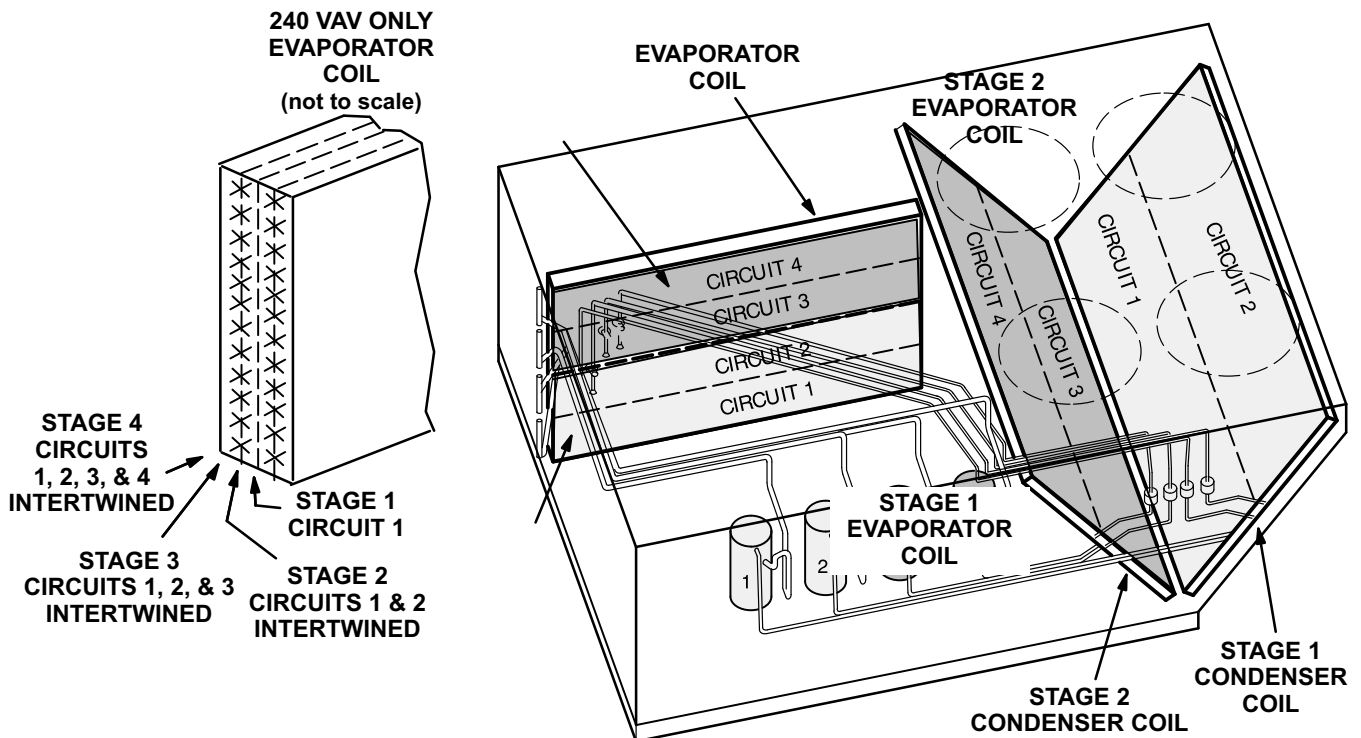
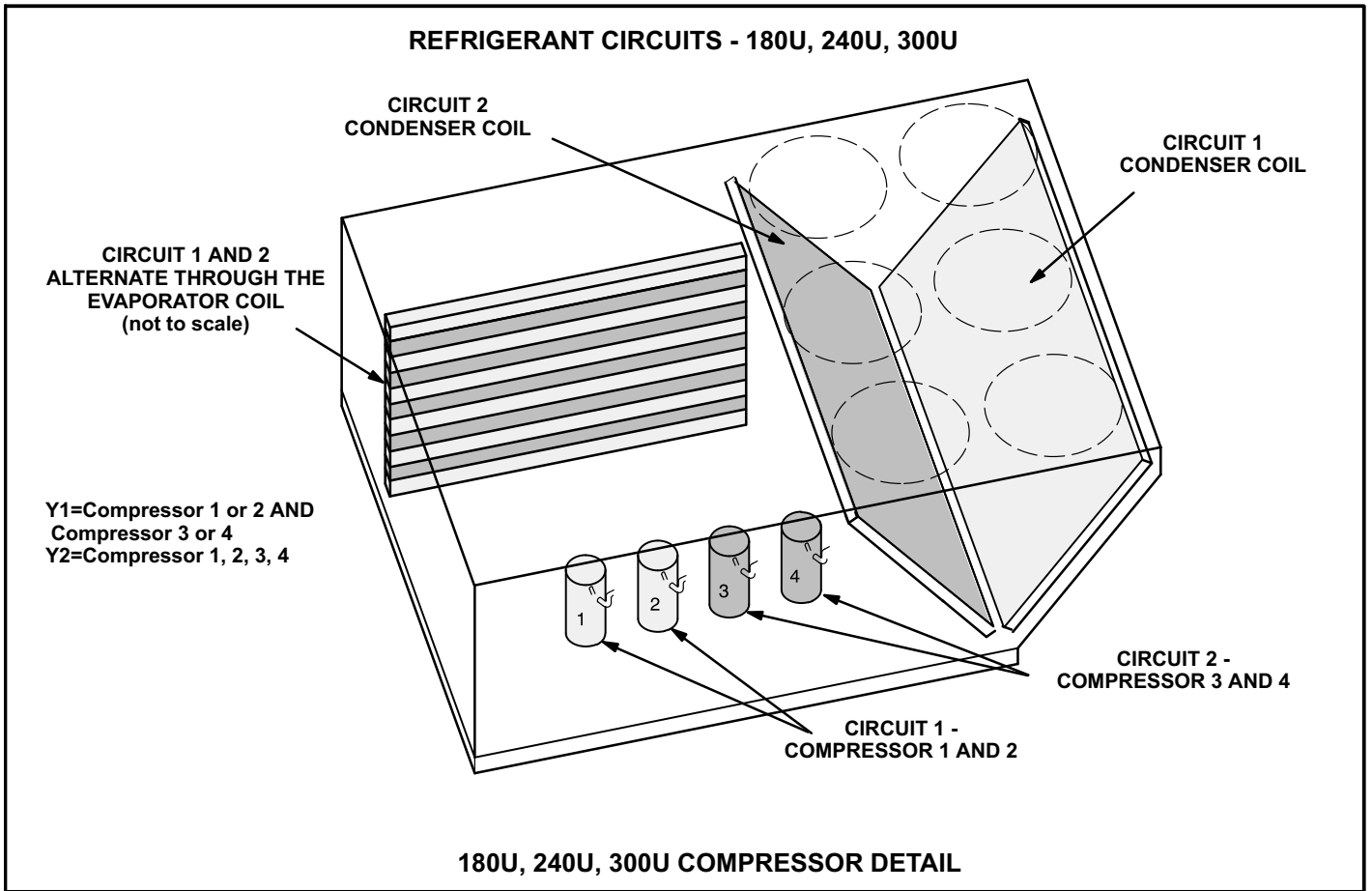


FIGURE 19





**FIGURE 20**

## V- SYSTEMS SERVICE CHECKS

### A-Cooling System Service Checks

LCH units are factory charged and require no further adjustment; however, charge should be checked periodically using the approach method. The approach method compares actual liquid temperature with the outdoor ambient temperature. See section III- CHARGING.

*NOTE-When unit is properly charged discharge line pressures should approximate those in tables 9 through 33.*

## VI-MAINTENANCE



### A-Filters

Units use six 24 X 24 X 2" pleated throw-away type filters. Filters may be accessed through the economizer / filter access door. Filters should be checked monthly (or more frequently in severe use) and cleaned or replaced regularly. Take note of the "AIR FLOW DIRECTION" marking on the filter frame when re-installing.

### B-Lubrication

All motors and blower wheels used in LCH units are pre-lubricated; no further lubrication is required.

### C-Supply Air Blower Wheel

Annually inspect supply air blower wheel for accumulated dirt or dust. Turn off power before attempting to remove access panel or to clean blower wheel.

### D-Evaporator Coil

Inspect and clean coil at beginning of each season. Clean using mild detergent or commercial coil cleanser. Check condensate drain pan and line, if necessary. Flush coil and condensate drain with water taking care not to get insulation, filters and return air ducts wet. Check connecting lines and coil for evidence of oil and refrigerant leaks.

### E-Condenser Coil

Clean condenser coil annually with detergent or commercial coil cleaner and inspect monthly during the cooling season. Check connecting lines and coil for evidence of oil and refrigerant leaks.

*NOTE-If owner complains of insufficient cooling, the unit should be gauged and refrigerant charge checked. Refer to Gauge Manifold Attachment and Charging sections in this manual.*

## F-Electrical

- 1- Check all wiring for loose connections.
- 2- Check for correct voltage at unit (unit operating).
- 3- Check amp-draw on both condenser fan motor and blower motor.  
Fan Motor Rating Plate \_\_\_\_\_ Actual \_\_\_\_\_  
Indoor Blower Motor Rating Plate \_\_\_\_\_ Actual \_\_\_\_\_

## VII-ACCESSORIES

The accessories section describes the application of most of the optional accessories which can be factory or field installed to the LCH units.

### A-LARMF and LARMFH Mounting Frames

When installing either the LCH units on a combustible surface for downflow discharge applications, the Lennox LARMF18/36 14-inch or 24-inch (356 mm or 610mm) height roof mounting frame is used. For horizontal discharge applications, use LARMFH18/24 26-inch or 37-inch (660mm or 940mm) height roof mounting frame. This frame converts unit from down-flow to horizontal air flow. The 37 inch (940mm) horizontal frame meets National Roofing Code requirements. The roof mounting frames are recommended in all other applications but not required. If the LCH units are not mounted on a flat (roof) surface, they MUST be supported under all edges and under the middle of the unit to prevent sagging. The units MUST be mounted level within 1/16" per linear foot or 5mm per meter in any direction.

The assembled LARMF18/36 mounting frame is shown in figure 21. Refer to the roof mounting frame installation instructions for details of proper assembly and mounting. The roof mounting frame MUST be squared to the roof and level before mounting. Plenum system MUST be installed before the unit is set on the mounting frame. Typical roof curbing and flashing is shown in figure 22. Refer to the roof mounting frame installation instructions for proper plenum construction and attachment.

### B-Control Systems

The A55 Unit Controller provides all control function for the rooftop unit. Default operation requires a standard room thermostat or direct digital controller (DDC). The A55 can also control the unit from a zone temperature sensor. The A55 Unit Controller is a network controller when daisy-chained to the L Connection® Network Control System. For ease of configuration, the A55 can be connected to a PC with Unit Controller PC software installed.

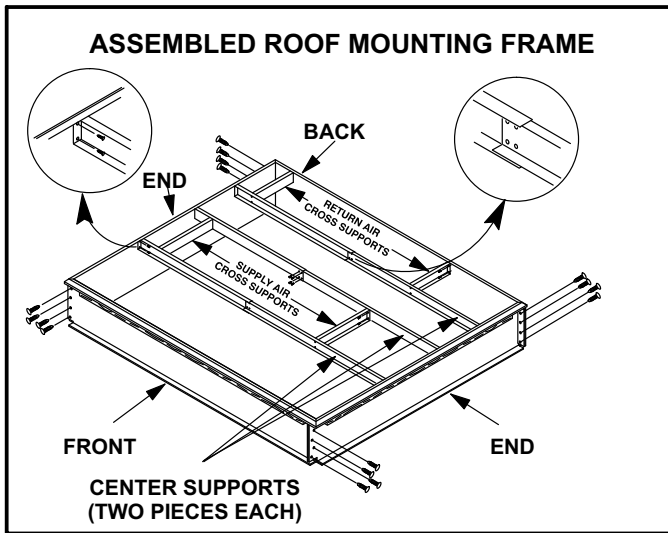


FIGURE 21

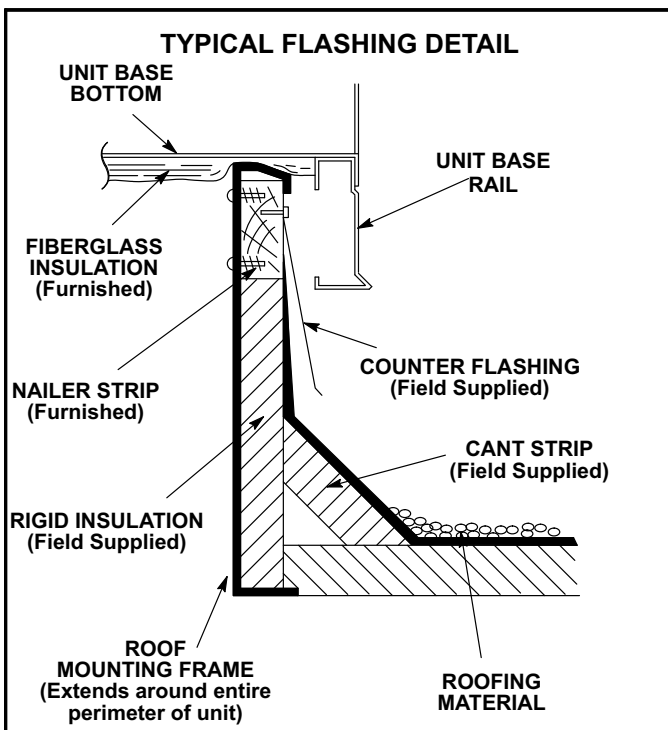


FIGURE 22

### C-Transitions

Optional supply/return transitions LASRT18/24 are available for use with LCH series units utilizing optional LARMF18/36 roof mounting frame. Transition must be installed in the LARMF18/36 mounting frame before mounting the unit to the frame. Refer to the manufacturer's instructions included with the transition for detailed installation procedures.

### D-Supply and Return Diffusers

Optional flush mount diffuser/return FD11 and extended mount diffuser/return RTD11 are available for use with all LCH units. Refer to manufacturer's instructions included with transition for detailed installation procedures.

### E-C1DAMP10 & E1DAMP20 Outdoor Air Dampers

C1DAMP10C and E1DAMP20C (figure 23) consist of a set of dampers which may be manually or motor operated to allow up to 25 percent outside air into the system at all times (see figure 23). Either air damper can be installed in LCH units. Washable filter supplied with the outdoor air dampers can be cleaned with water and a mild detergent. It should be sprayed with Filter Handicoater when dry prior to reinstallation. Filter Handicoater is R.P. Products coating no. 418 and is available as Part No. P-8-5069.

### F-E1ECON15C-2 Standard and E1ECON17C-1 High Performance Economizer (Field or Factory Installed)

The optional E1ECON15 economizer can be used with downflow and horizontal air discharge applications. The economizer uses outdoor air for free cooling when temperature and/or humidity is suitable. An economizer hood is furnished with the economizer.

The economizer is controlled by the A55 Unit Controller.

The economizer will operate in one of four modes. Each mode requires a different A55 Unit Controller DIP switch setting. Each mode also requires different sensors.

The following is a brief description. See economizer installation instruction for more detail.

#### 1-"TMP" MODE (SENSIBLE TEMPERATURE)

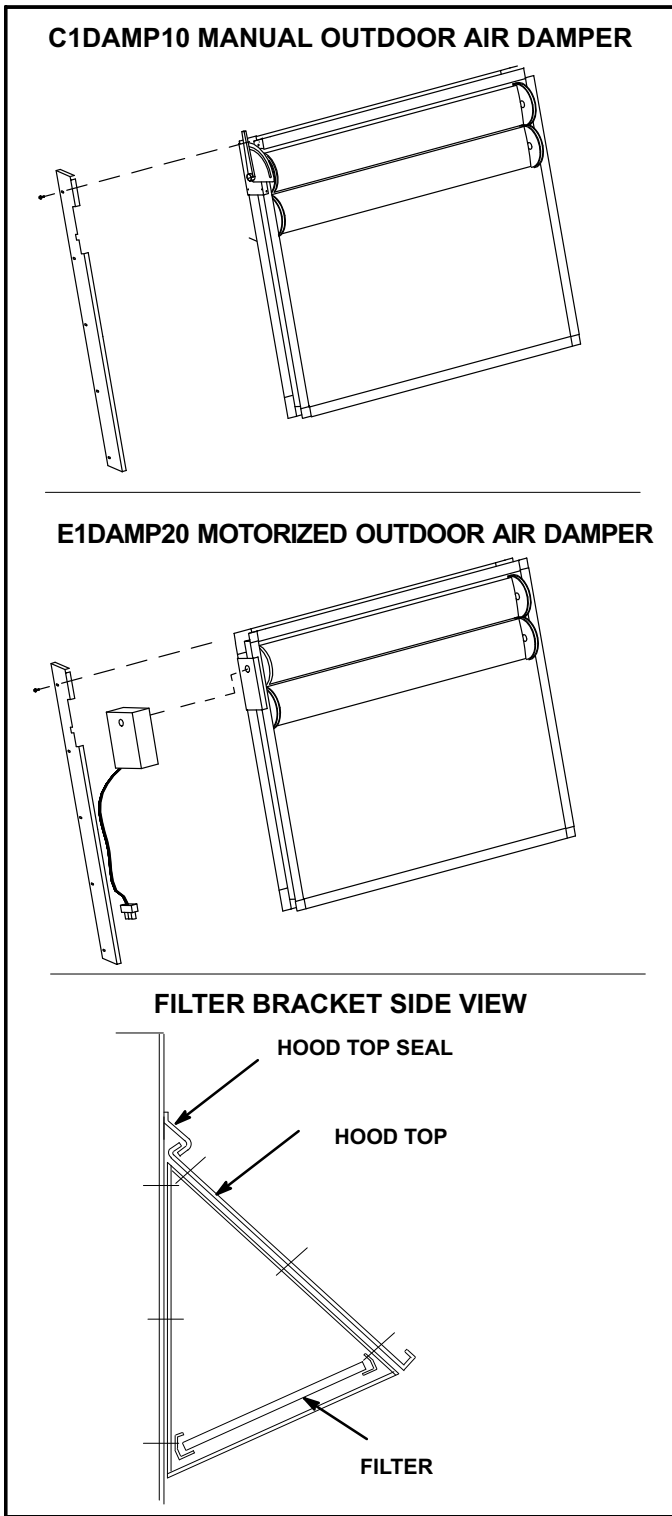
In the "TMP" mode, the IMC uses input from the factory installed RT6 Supply Air Sensor, RT16 Return Air Sensor and RT17 Outdoor Air Sensor to determine suitability of outside air and economizer damper operation. When outdoor sensible temperature is less than return air sensible temperature, outdoor air is used for cooling. This may be supplemented by mechanical cooling to meet comfort demands. This application does not require additional optional sensors.

#### 2-"ODE" MODE (OUTDOOR ENTHALPY)

The "ODE" or outdoor enthalpy mode requires a field-provided and -installed Honeywell C7400 enthalpy sensor (16K96). The sensor monitors outdoor air temperature and humidity (enthalpy). When outdoor air enthalpy is below the enthalpy control setpoint, the economizer modulates to allow outdoor air for free cooling.

#### 3-"DIF" MODE (DIFFERENTIAL ENTHALPY)

The "DIF" or differential enthalpy mode requires two field-provided and -installed Honeywell C7400 enthalpy sensors (16K97). One sensor is installed in the outside air opening and the other sensor is installed in the return air opening. When the outdoor air enthalpy is below the return air enthalpy, the economizer opens to bring in outdoor air for free cooling.



**FIGURE 23**

#### 4-“GLO” MODE (GLOBAL)

*Global Mode* - The “GLO” or global mode is used with an energy management system which includes a global control feature. Global control is used when multiple units (in one location) respond to a single outdoor air sensor. Each energy management system uses a specific type of outdoor sensor which is installed and wired by the controls contractor.

*Motorized Outdoor Air Damper* - The “GLO” mode is also used when a motorized outdoor air damper is installed in the system.

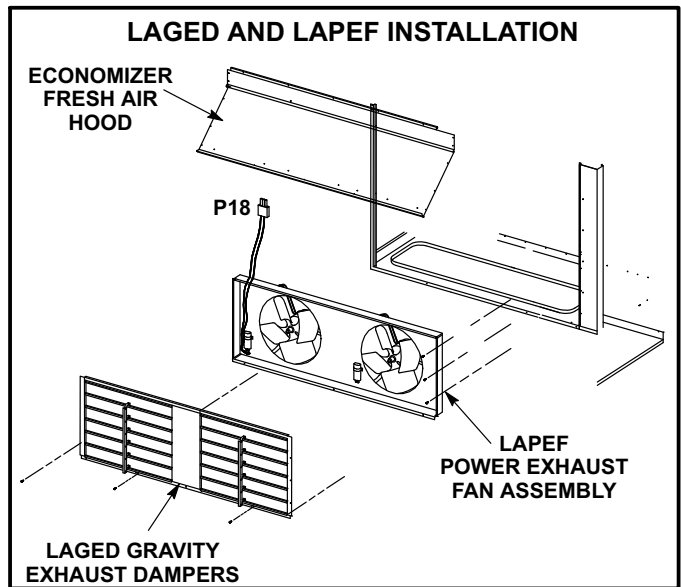
*NOTE* - All economizer modes of operation will modulate dampers to 55° F (13° C) supply air.

#### G-Gravity Exhaust Dampers

C1DAMP50C dampers (figure 24) are used in downflow and LAGEDH are used in horizontal air discharge applications. LAGEDH gravity exhaust dampers are installed in the return air plenum. The dampers must be used any time an economizer or power exhaust fans are applied to LCH series units. An exhaust hood is furnished with the gravity exhaust damper.

Gravity exhaust dampers allow exhaust air to be discharged from the system when an economizer and/or power exhaust is operating. Gravity exhaust dampers also prevent outdoor air infiltration during unit off cycle. See installation instructions for more detail.

*NOTE* - Gravity exhaust dampers are required with power exhaust.



**FIGURE 24**

#### H-C1PWRE10 Power Exhaust Fans

C1PWRE10 power exhaust fans are used in downflow applications only. C1PWRE10 fans require optional downflow gravity exhaust dampers and E1ECON15 economizers. Power exhaust fans provide exhaust air pressure relief and also run when return air dampers are closed and supply air blowers are operating. Figure 24 shows the location of the power exhaust fans. See installation instructions for more detail.

#### I-Smoke Detectors A171, A172, A173

Photoelectric smoke detectors are a factory- and field-installed option. The smoke detectors can be installed in the supply air section (A172), return air section (A171), or in both the supply and return air section. Smoke detection control module (A173) is located below the control panel. Wiring for the smoke detectors are shown on the temperature control section (C) wiring diagram in back of this manual.

## J-Blower Proving Switch S52

The blower proving switch monitors blower operation and locks out the unit in case of blower failure. The switch is N.O. and closes at .15" W.C. (3.3 Pa) The switch is mounted on the middle left corner of the blower support panel. Wiring for the blower proving switch is shown on the temperature control section (C) wiring diagram in back of this manual.

## K-Indoor Air Quality (CO<sub>2</sub>) Sensor A63

The indoor air quality sensor monitors CO<sub>2</sub> levels and reports the levels to the A55 Unit Controller. The board adjusts the economizer dampers according to the CO<sub>2</sub> levels. The sensor is mounted next to the indoor thermostat or in the return air duct. Refer to the indoor air quality sensor installation instructions for proper adjustment. Wiring for the indoor air quality switch is shown on the temperature control section (C) wiring diagram in back of this manual.

## L-Dirty Filter Switch S27

The dirty filter switch senses static pressure increase indicating a dirty filter condition. The switch is N.O. and closes at 1" W.C. (248.6 Pa) The switch is mounted on the top corner of the economizer. Wiring for the dirty filter switch is shown on the temperature control section (C) wiring diagram in back of this manual.

## M-Optional UVC Lights

The Healthy Climate® germicidal light emits ultraviolet (UVC) energy that has been proven effective in reducing microbial life forms (viruses, bacteria, yeasts and molds) in the air.

UVC germicidal lamps greatly reduce the growth and proliferation of mold and other bio-aerosols (bacteria and viruses) on illuminated surfaces.

Germicidal lamps are NOT intended to be used for removal of active mold growth. Existing mold growth must be appropriately removed PRIOR to installation of the germicidal lamp.

Refer closely to UVC light installation instruction warnings when servicing units.

## N-Drain Pan Overflow Switch S149 (optional)

The overflow switch is used to interrupt cooling operation when excessive condensate collects in the drain pan. The N.O. overflow switch is controlled by K220 and DL46 relays, located in the unit control panel. When the overflow switch closes, 24VAC power is interrupted and after a five-second delay unit compressors are de-energized. Once the condensate level drops below the set level, the switch will open. After a five-minute delay the compressor will be energized.

## P-Factory-Installed Hotgas Reheat

### General

Hotgas Reheat units provide a dehumidifying mode of operation. These units contain a reheat coil adjacent to and downstream of the evaporator coil. Reheat coil solenoid valves, L14 and L30, route hot discharge gas from the compressor to the reheat coil. Return air pulled across the evaporator coil is cooled and dehumidified; the reheat coil adds heat to supply air.

See figure 25 for 156, 180 and 210 reheat refrigerant routing, figure 26 for 156, 180 and 210 normal cooling refrigerant routing, figure 27 for 240 and 300S reheat refrigerant routing and figure 28 for 240 and 300S normal cooling refrigerant routing.

### L14 and L30 Reheat Coil Solenoid Valves

When Unit Controller (P298-5 or J299-8) indicates room conditions require dehumidification, L14 and L30 reheat valves are energized (Unit Controller P269-3 or P269-4) and refrigerant is routed to the reheat coil.

### Reheat Setpoint

Reheat is factory-set to energize when indoor relative humidity rises above 60% (default). The reheat setpoint can be adjusted by changing Unit Controller *Settings - Control* menu. A setting of 100% will operate reheat from an energy management system digital output. The reheat setpoint can also be adjusted using an optional Network Control Panel (NCP).

Reheat will terminate when the indoor relative humidity falls 3% (57% default) or the digital output de-energizes. The reheat deadband can be adjusted at *Settings - Control* menu.

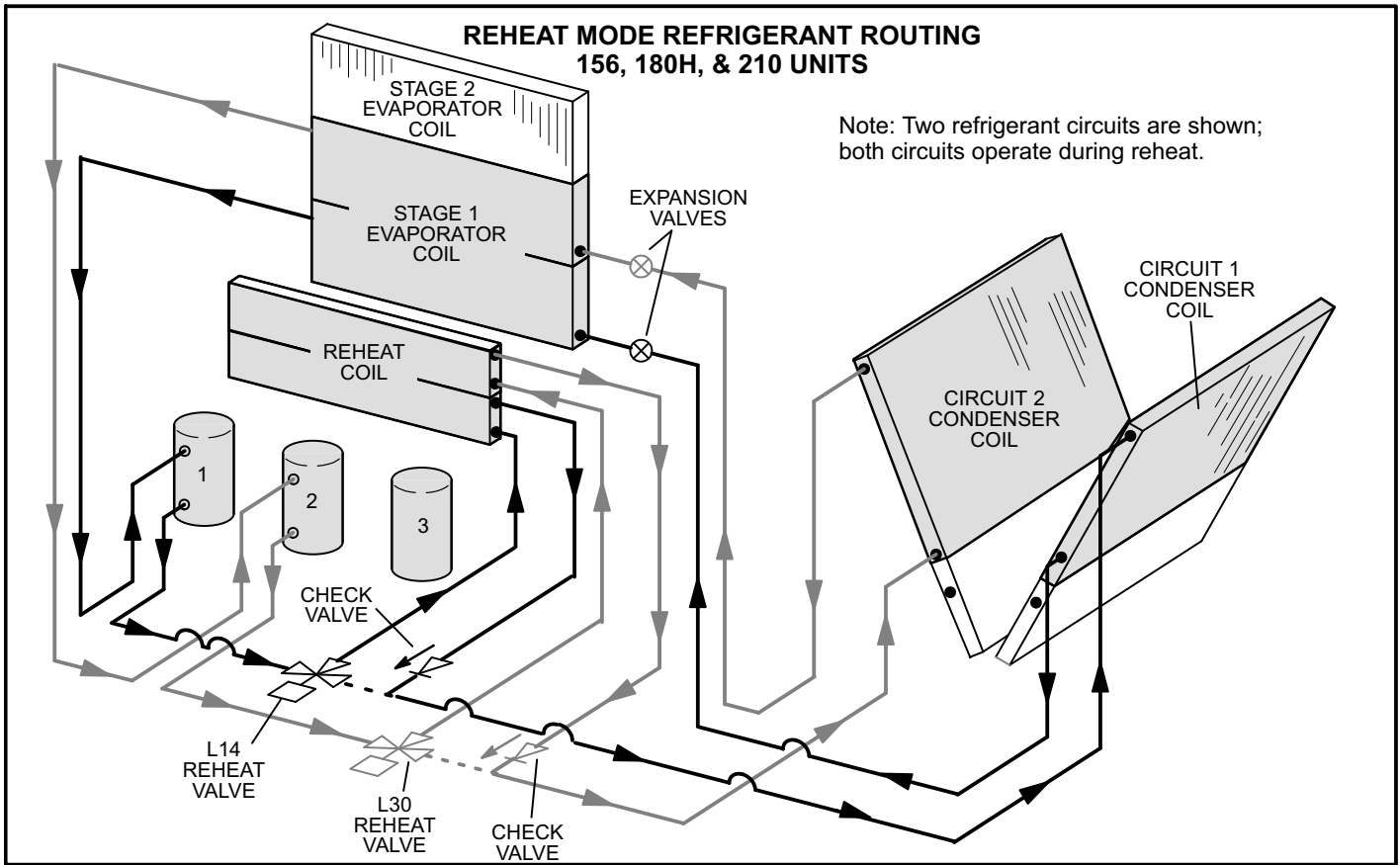
### A91 Humidity Sensor

Relative humidity should correspond to the sensor (A91) output voltage listed in table 36. For example: if indoor air relative humidity is 80%  $\pm$  3%, the humidity sensor output should read 8.00VDC.

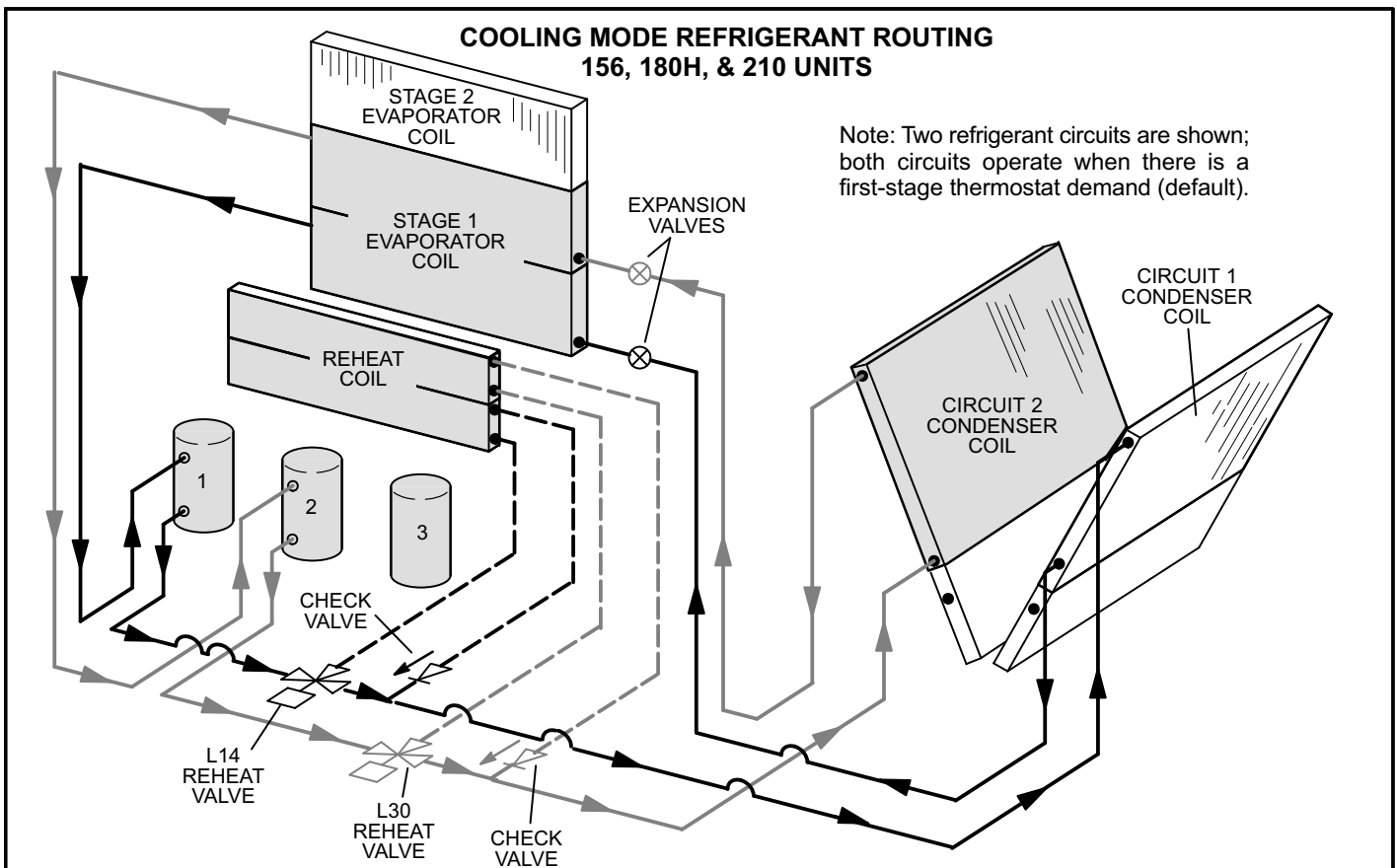
Check the sensor output annually for accuracy. Keep the air intake openings on the sensor clean and free of obstructions and debris.

TABLE 36

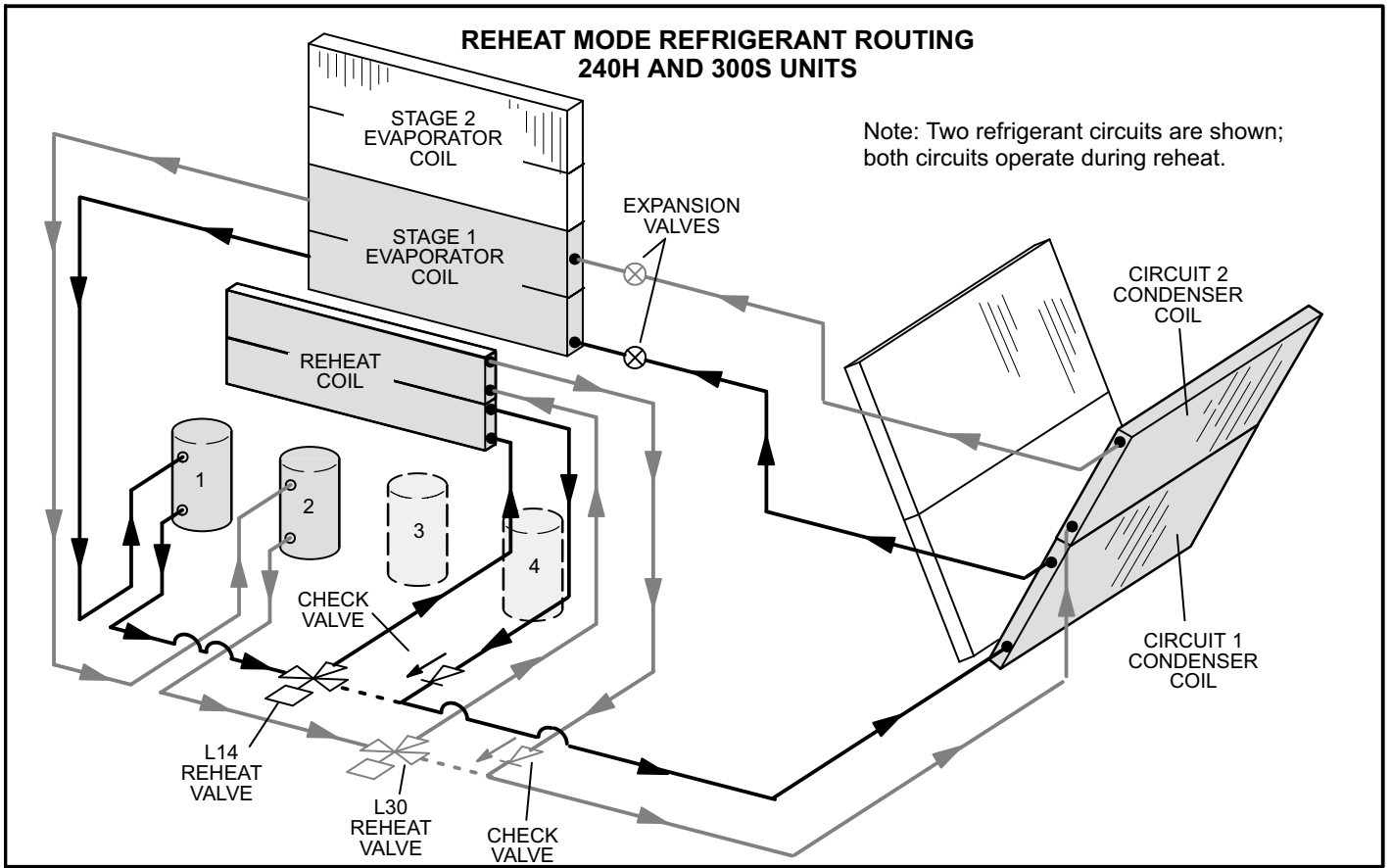
Relative Humidity (%RH $\pm$ 3%)	Sensor Output (VDC)
20	2.00
30	3.00
40	4.00
50	5.00
60	6.00
70	7.00
80	8.00
90	9.00



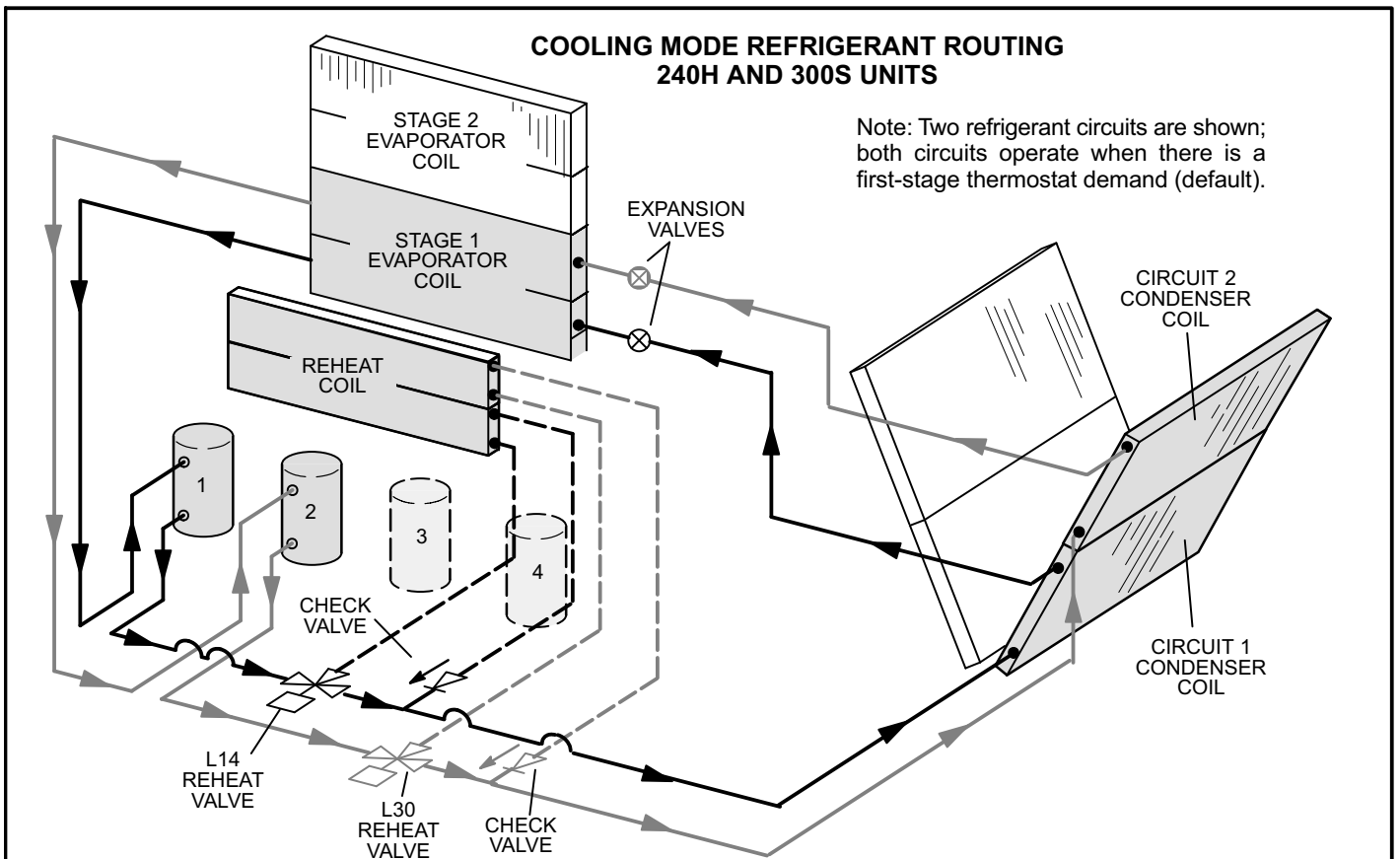
**FIGURE 25**



**FIGURE 26**



**FIGURE 27**



**FIGURE 28**

# ⚠ WARNING

**Product contains fiberglass wool. Disturbing the insulation in this product during installation, maintenance, or repair will expose you to fiberglass wool. Breathing this may cause lung cancer. (Fiberglass wool is known to the State of California to cause cancer.)**  
**Fiberglass wool may also cause respiratory, skin and eye irritation.**  
**To reduce exposure to this substance or for further information, consult material safety data sheets available from address shown on unit nameplate or contact your supervisor.**

## Check-Out

Test Humiditrol operation using the following procedure.

- 1 Make sure reheat is wired as shown in wiring section.
- 2 Make sure unit is in local thermostat mode.
- 3 Select Unit Controller *Service - Test*.

*The blower, compressor 1 and compressor 2 (reheat) should be operating. Reheat mode will appear on the Unit Controller display.*

- 4 Deselect Unit Controller *Service - Test*.

*Compressor 1 and 2 (reheat) should de-energize,, blower should still be energized.*

## Default Reheat Operation

Reheat will operate as shown in table 37 once three conditions are met:

- 1 Blower must be operating.
- 2 System must be in occupied mode.
- 3 System must NOT be operating in heating mode.

**IMPORTANT - Free cooling does not operate during reheat.**

For other reheat control options, refer to the Unit Controller manual.

## Additional Cooling Stages

Units are shipped from the factory to provide two stages of cooling.

Three stages of cooling is available in zone sensor mode. Three stages of cooling is also available by installing a transfer relay and a three-stage thermostat. Refer to the Main Control Operation section in the Unit Controller manual when using the transfer relay.

Four stages of cooling is available in zone sensor mode on units with four compressors (240, 300S).

Compressors are not de-energized when unit operation changes from cooling to reheat or from reheat to cooling. Instead, L14 and L30 reheat valves are energized (reheat) or de-energized (cooling).

*NOTE - Another thermostat staging option is available which allows both compressors to be energized during free cooling. See Unit Controller manual for details.*

**TABLE 37  
REHEAT OPERATION**

<b>Two-Stage Thermostat - Default</b>		
T'stat and Humidity Demands	Operation	
	156, 180, 210 (3-Compressors)	240, 300S (4-Compressors)
Reheat Only	Compressor 1 & 2 Reheat	Compressor 1 & 2 Reheat
Reheat & Y1	Compressor 1 & 2 Reheat and Compressor 3 Cooling <sup>1</sup>	Compressor 1 & 2 Reheat and Compressor 3 & 4 Cooling <sup>1</sup>
Reheat & Y1 & Y2	Compressor 1, 2, & 3 Cooling <sup>3</sup>	Compressor 1, 2, 3 & 4 Cooling <sup>3</sup>
<b>Three-Stage Thermostat (Transfer relay required)</b>		
T'stat and Humidity Demands	Operation	
	156, 180, 210 (3-Compressors)	240, 300S (4-Compressors)
Reheat Only	Compressor 1 & 2 Reheat	Compressor 1 & 2 Reheat
Reheat & Y1	Compressor 1 & 2 Reheat and Compressor 3 Cooling <sup>1</sup>	Compressor 1 & 2 Reheat and Compressor 3 Cooling <sup>1</sup>
Reheat Y1 & Y2	Compressor 1, & 2, Cooling <sup>2</sup>	Compressor 1 & 2 Reheat and Compressor 3, & 4 Cooling <sup>3</sup>
Reheat Y1 & Y2 & Y3	Compressor 1, 2, & 3 Cooling <sup>3</sup>	Compressor 1, 2, 3, & 4 Cooling <sup>4</sup>



<b>Four-Stage Zone Sensor Mode</b>		
Cooling* and Humidity** Demands	Operation	
	156, 180, 210 (3-Compressors)	240, 300S (4-Compressors)
Reheat Only	Compressor 1 & 2 Reheat	Compressor 1 & 2 Reheat
Reheat & Y1	Compressor 1 & 2 Reheat and Compressor 3 Cooling <sup>1</sup>	Compressor 1 & 2 Reheat and Compressor 3 Cooling <sup>1</sup>
Reheat & Y1 & Y2	Compressor 1, & 2, Cooling <sup>2</sup>	Compressor 1 & 2 Reheat and Compressor 3 & 4 Cooling <sup>2</sup>
Reheat & Y1 & Y2 & Y3	Compressor 1, 2, & 3 Cooling <sup>3</sup>	Compressor 1, 2, & 3 Cooling <sup>3</sup>
Reheat & Y1 & Y2 & Y3 & Y4	Compressor 1, 2, & 3 Cooling <sup>4</sup>	Compressor 1, 2, 3, & 4 Cooling <sup>5</sup>

\*Cooling stage is initiated when zone temperature is higher than the cooling setpoint plus the appropriate stage differential.

\*\*Reheat demand is initiated when relative humidity is higher than relative humidity setpoint.

<sup>1</sup>If there is no reheat demand and outdoor air is suitable, free cooling will operate.

<sup>2</sup>If there is no reheat demand and outdoor air is suitable, free cooling and compressor 1 will operate.

<sup>3</sup>If there is no reheat demand and outdoor air is suitable, free cooling and compressor 1 and 2 will operate.

<sup>4</sup>If there is no reheat demand and outdoor air is suitable, free cooling, compressor 1, 2 and 3 will operate.

<sup>5</sup>If there is no reheat demand and outdoor air is suitable, free cooling, compressor 1, 2, 3 and 4 will operate.

The following conditions must be met before reheat will be energized:  
(factory-default; see Unit Controller manual for other options)

1- Blower must be operating.

2- System must be in occupied mode.

3- System must NOT be operating in heating mode.

## VIII--Staged Blower

### Start-Up

#### A-Design Specifications

Use table 38 to fill in field-provided, design specified blower CFM for appropriate unit.

If only high and low cooling design specifications are provided, set the medium cooling CFM at the high or low cooling design spec or any CFM between.

#### B-Set Maximum CFM

Use table 38 to determine highest blower CFM for appropriate unit. Adjust the blower pulley to deliver that amount of CFM with only the blower operating. See *Determining Unit CFM* in the Blower Operation and Adjustment section.

**TABLE 38**  
**Blower CFM Design Specifications**

Unit	T'Stat or Zone Control Stages	Blower Speed	Design Specified CFM
156, 180, 210	2	Htg.	
		Clg. High	
		Clg. Low	
		Ventilation	
156, 180, 210	3 or 4	Htg.	
		Clg. High	
		Clg. Med.	
		Clg. Low	
		Ventilation	
240, 300	2	Htg.	
		Clg. High	
		Clg. Low	
		Ventilation	
240, 300	3	Htg.	
		Clg. High	
		Clg. Med.	
		Clg. Low	
		Ventilation	
240, 300	4	Htg.	
		Clg. High	
		Clg. Med. High	
		Clg. Med. Low	
		Clg. Low	
		Ventilation	

\*Available blower speeds vary by unit and thermostat stages.

## C-Enter Design Specifications Into M2 and M3 Controller

Use the following menu to enter the blower design specified CFM into the Unit Controller. Make sure blower CFM is within limitations shown in tables 39 and 40. Refer to the Unit Controller manual provided with unit.

**M2** - *Settings / Control / Guided Setup* (enter information as prompted by the Unit Controller if not already done).

**M3** - *SETUP > TEST & BALANCE > BLOWER >*

*Advanced Guided Setup* (enter information as prompted by the Unit Controller if not already done).

*Setup Equipment / Change MSAV® Settings? / Yes*

*Blower / Heat CFM  
Cooling High CFM<sup>1</sup>  
Cooling Low CFM<sup>1</sup>  
Vent CFM*

<sup>1</sup>The Unit Controller will prompt when more cooling stages are available depending on the number of compressors and the control mode.

#### D-Set Damper Minimum Position

To maintain required minimum ventilation air volumes when the unit is in the occupied mode, two minimum damper positions must be set. The Unit Controller will open the dampers to “Min OCP Blwr Low” when blower CFM is BELOW a “midpoint” CFM. The Unit Controller will open the damper to “Min OCP Blwr High” when blower CFM is at or ABOVE the “midpoint” CFM.

The Unit Controller will calculate the “midpoint” CFM.

#### Set Minimum Position 1

Use the following menu in the Unit Controller to set “Min OCP Blwr Low” for the blower CFM below the “midpoint” CFM. When navigating into this menu, the Unit Controller will bring on the corresponding blower speed and allow damper position adjustment.

**M2** - *Settings / Control / MSAV / Damper / Low Speed*

**M3** - *SETTINGS > RTU OPTIONS > EDIT PARAMETER > ENTER DATA ID - 9 > MIN DAMPER LOW BLOWER = X.X%*

Measure the intake air CFM. If the CFM is lower than the design specified CFM for ventilation air, use the Unit Controller to increase the damper percent open. If the CFM is higher than specified, decrease the damper percent open.

*Note - Intake air CFM can also be determined using the outdoor air temperature, return air temperature and mixed air temperature. Refer to the economizer or outdoor air damper installation instructions.*

## Set Minimum Position 2

Use the same menu in the Unit Controller to set “Min OCP Blwr High” for the blower CFM above the “midpoint” CFM. When navigating into this menu, the Unit Controller will bring on the corresponding blower speed and allow damper position adjustment.

**M2 - Settings / Control / MSAV / Damper / High Speed**

**M3 - SETTINGS > RTU OPTIONS > DAMPER > MIN  
DAMPER POSITION BLOWR ON HIGH = X.X%**

Measure the intake air CFM. If the CFM is lower than the design specified CFM for ventilation air, use the Unit Controller to increase the damper percent open. If the CFM is higher than specified, decrease the damper percent open.

*Note - Intake air CFM can also be determined using the outdoor air temperature, return air temperature and mixed air temperature. Refer to the economizer or outdoor air damper installation instructions.*

### E-VFD Bypass

#### M2 Controller

The supply air VFD is factory-set to by-pass the VFD manually. To by-pass the VFD and operate the blower in the constant air volume mode, use the following Unit Controller menu and set to “engaged”:

*Settings / Control / MSAV / VFD Bypass*

To configure the unit to by-pass the VFD automatically, use the following Unit Controller menu and set to “automatic”:

*Settings / Install / New M2 / MSAV VFD Bypass*

*Caution - Units not equipped with a VFD will be set to Settings / Control / MSAV VFD Bypass / None. The blower motor could be damaged and/or result in product or property damage if the setting is changed to automatic or manual.*

#### M3 Controller

The supply air inverter is factory-set to by-pass the inverter manually. To by-pass the inverter and operate the blower in the constant air volume mode, use the following Unit Controller menu and set to “engaged”:

**SETTINGS > RTU OPTIONS > BLOWER > VFD BY-  
PASS**

To configure the unit to by-pass the inverter automatically, use the following Unit Controller menu.

**SETUP > INSTALL**

Press SAVE until the menu reads:

**CONFIGURATION ID 1**

Change the 6<sup>th</sup> character position to A for automatic by-pass option.

Press SAVE

*Caution - Units not equipped with an inverter will have the 6<sup>th</sup> character set to N, indicating the inverter is not by-passed. The blower motor could be damaged and/or result in product or property damage if the setting is changed to automatic or manual.*

**TABLE 39  
MINIMUM AND MAXIMUM CFM**

<b>Gas Heat Minimum CFM</b>		
Unit	Gas Heat Size	Airflow CFM
LGH156-300S	Low, Std. Med.	4500
LGH180-300S	High	5125
<b>Electric Heat Minimum CFM</b>		
Unit	Heat Size (kW)	Airflow CFM
LCH156	All	5200
LCH180-300S	All	6000
<b>Cooling Minimum CFM - 220 CFM/ton</b>		
Unit	Blower Speed	Airflow CFM
LGH/LCH156	Low, Med. Low, Med., Med. High	2860
LGH/LCH180	Low, Med. Low, Med., Med. High	3300
LGH/LCH210	Low, Med. Low, Med., Med. High	3850
LGH/LCH240	Low, Med. Low, Med., Med. High	4400
LGH/LCH300S	Low, Med. Low, Med., Med. High	5500
<b>Cooling Minimum CFM - 280 CFM/ton</b>		
Unit	Blower Speed	Airflow CFM
LGH/LCH156	High	3640
LGH/LCH180	High	4200
LGH/LCH210	High	4900
LGH/LCH240	High	5600
LGH/LCH300S	High	7000
<b>Smoke and Ventilation Minimum CFM - 150 CFM/ton</b>		
Unit	Not Applicable	Airflow CFM
LGH/LCH156	NA	1950
LGH/LCH180	NA	2250
LGH/LCH210	NA	2625
LGH/LCH240	NA	3000
LGH/LCH300S	NA	3750
<b>Heating and Cooling Maximum CFM - 480 CFM/ton</b>		
Unit	Blower Speed	Airflow CFM
LGH/LCH156	High	6240
LGH/LCH180	High	7200
LGH/LCH210	High	8400
LGH/LCH240	High	9600
LGH/LCH300S	High	12000

**TABLE 40  
MINIMUM AND MAXIMUM CFM - 180U, 240U, 300U**

<b>Gas Heat Minimum CFM</b>		
Unit	Gas Heat Size	Airflow CFM
LGH180U/240U/300U	Low, Std., Med.	4500
LGH180U/240U/300U	High	5125
<b>Electric Heat Minimum CFM</b>		
Unit	Heat Size (kW)	Airflow CFM
LCH180U/240U/300U	All	6000
<b>Cooling 1 Minimum CFM - 130 CFM/ton</b>		
Unit	Blower Speed	Airflow CFM
LGH/LCH180U	Low	1950
LGH/LCH240U	Low	2600
LGH/LCH300U	Low	3250
<b>Cooling 2 Minimum CFM - 160 CFM/ton</b>		
Unit	Blower Speed	Airflow CFM
LGH/LCH180U	Med. Low	2400
LGH/LCH240U	Med. Low	3200
LGH/LCH300U	Med. Low	4000
<b>Cooling 3 Minimum CFM - 190 CFM/ton</b>		
Unit	Blower Speed	Airflow CFM
LGH/LCH180U	High	2850
LGH/LCH240U	High	3800
LGH/LCH300U	High	4750
<b>Cooling 4 Minimum CFM - 220 CFM/ton</b>		
Unit	Blower Speed	Airflow CFM
LGH/LCH180U	High	3300
LGH/LCH240U	High	4400
LGH/LCH300U	High	5500
<b>Smoke and Ventilation Minimum CFM - 150 CFM/ton</b>		
Unit	Not Applicable	Airflow CFM
LGH/LCH180U		2250
LGH/LCH240U		3000
LGH/LCH300U		3750
<b>Heating and Cooling Maximum CFM - 480 CFM/ton</b>		
Unit	Blower Speed	Airflow CFM
LGH/LCH180U	High	7200
LGH/LCH240U	High	9600
LGH/LCH300U	High	12000

## Operation

This is a summary of cooling operation.

*Note - During a dehumidification demand the blower operates at the highest speed. Free cooling is locked-out during reheat operation. Refer to reheat start-up and operation section for details.*

### A-Two-Stage T'Stat; 3- and 4-Compressor Units

1-Economizer With Outdoor Air Suitable

Y1 Demand -

Compressors Off  
Blower Cooling Low  
Dampers modulate

Y2 Demand -

Compressors Off  
Blower Cooling High  
Dampers Modulate

*156, 180H, 210, 240H, 300S - If dampers are at maximum open for three minutes, compressor 1 and 2 are energized and blower stays on cooling high.*

*180U, 240U, 300U - If dampers are at maximum open for three minutes, two compressors (one from each circuit) are energized and blower stays on cooling high.*

2-No Economizer or Outdoor Air Not Suitable

Y1 Demand -

First-stage Compressors On  
Blower Cooling Low  
Dampers Minimum Position

Y2 Demand -

All Compressors On  
Blower Cooling High  
Dampers Minimum Position

### B-Three-Stage T'Stat, 3 and 4 Compressor Units AND Zone Sensor (4 Clg. Stages), 3-Compressor Units

1-Economizer With Outdoor Air Suitable

#### Three-Compressor Units:

Y1 Demand -

Compressors Off  
Blower Cooling Low  
Dampers Modulate

Y2 Demand -

Compressors Off  
Blower Cooling High  
Dampers Modulate

*Note - If dampers are at maximum open for three minutes, compressor 1 is energized and blower stays on cooling high.*

Y3 Demand -

Compressors 1 and 2 On  
Blower Cooling High  
Dampers Maximum Open

Y4 Demand -

All Compressors On  
Blower Cooling High  
Dampers Maximum Open

#### Four-Compressor Units:

Y1 Demand -

Compressors Off  
Blower Cooling Low  
Dampers modulate

Y2 Demand -

Compressors Off  
Blower Cooling High  
Dampers Modulate

*156, 180H, 210, 240H, 300S - If dampers are at maximum open for three minutes, compressors 1 and 2 are energized and blower stays on cooling high.*

*180U, 240U, 300U - If dampers are at maximum open for three minutes, two compressors (one from each circuit) are energized and blower stays on cooling high.*

Y3 Demand -

Compressors 1, 2 and 3 On  
(180U, 240U, 300U any three compressors are on  
Blower Cooling High  
Dampers Maximum Open

2-No Economizer or Outdoor Air Not Suitable

#### Three-Compressor Units:

Y1 Demand -

Compressor 1 On  
Blower Cooling Low

Y2 Demand -

Compressors 1 and 2 On  
Blower Cooling Medium

Y3 or Y4 Demand -

All Compressors On  
Blower Cooling High

#### Four-Compressor Units:

Y1 Demand -

Compressors 1 and 2 On  
180U, 240U, 300U - Two Compressors On  
(one from each circuit)  
Blower Cooling Low

Y2 Demand -

Compressors 1, 2 and 3 On  
180U, 240U, 300U any three compressors are On  
Blower Cooling Medium

Y3 Demand -

All Compressors On  
Blower Cooling High

### C-Zone Sensor (4 Clg. Stages), 4-Compressor Units

1-Economizer With Outdoor Air Suitable

Y1 Demand -

Compressors Off  
Blower Cooling Low  
Dampers modulate

#### Y2 Demand -

Compressors Off  
Blower Cooling High  
Dampers Modulate

156, 180H, 210, 240H, 300S - If dampers are at maximum open for three minutes, compressor 1 is energized and blower stays on cooling high.

180U, 240U, 300U - If dampers are at maximum open for three minutes, two compressors (one from each circuit) are energized and blower stays on cooling high.

#### Y3 Demand -

Compressors 1 and 2 On  
180U, 240U, 300U - Two Compressors On  
(one from each circuit)  
Blower Cooling High  
Dampers Maximum Open

#### Y4 Demand -

All Compressors On  
Blower Cooling High  
Dampers Maximum Open

#### 2-No Economizer or Outdoor Air Not Suitable

#### Y1 Demand -

Compressor 1 On  
180U, 240U, 300U - Two Compressors On  
(one from each circuit)  
Blower Cooling Low

#### Y2 Demand -

Compressors 1 and 2 On  
180U, 240U, 300U - Two Compressors On  
(one from each circuit)  
Blower Cooling Medium Low

#### Y3 Demand -

Compressors 1, 2 and 3 On  
180U, 240U, 300U any three compressors are On  
Blower Cooling Medium High

#### Y4 Demand -

All Compressors On  
Blower Cooling High

### IX--VAV System

**NOTE** - Units equipped a Variable Frequency Drive (VFD) are designed to operate on balanced, three-phase power. Operating units on unbalanced three-phase power will reduce the reliability of all electrical components in the unit. Unbalanced power is a result of the power delivery system supplied by the local utility company. Factory-installed inverters are sized to drive blower motors with an equivalent current rating using balanced three-phase power. If unbalanced three-phase power is supplied; the installer must replace the existing factory-installed inverter with an inverter that has a higher current rating to allow for the imbalance.

Refer to the installation instructions for additional information and available replacements.

Units may contain an optional supply air blower equipped with a variable frequency drive A96 (VFD) which varies supply air CFM.

The supply air VFD (A96) is located near the compressors. See figure 30.

#### A-Start-Up

1 A pressure transducer (A30) is shipped in a box in the blower compartment. Install the transducer according to manufacturer's instructions.

*Note* - Make sure the transducer is installed in the main duct at least 2/3 of the distance away from the unit.

2 Two twisted pairs of shielded cable must be used to connect the pressure transducer. See figure 29. J/P300 connector is hanging in the control box.

3 Open all zone dampers and/or boxes.

4 Locate the A55 Unit Controller. Refer to figure 30.

5 Use the Unit Controller to calibrate the blower CFM. Select the **SETUP->TEST & BALANCE->BLOWER** menu to start the blower. The Unit Controller will display the percent of blower speed. Adjust blower speed percentage to meet design airflow specifications. Allow blower speed to stabilize.

6 Press SAVE to display the current static pressure. If the static pressure meets the design specification, press SAVE again to set the setpoint. If the static pressure does not meet the design specification, adjust the pressure and press SAVE to set the setpoint.

7 Record new setpoints in table 41.

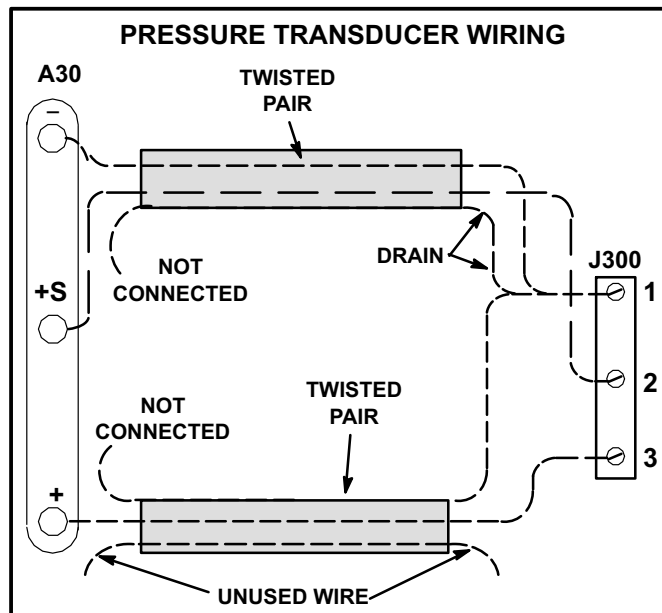
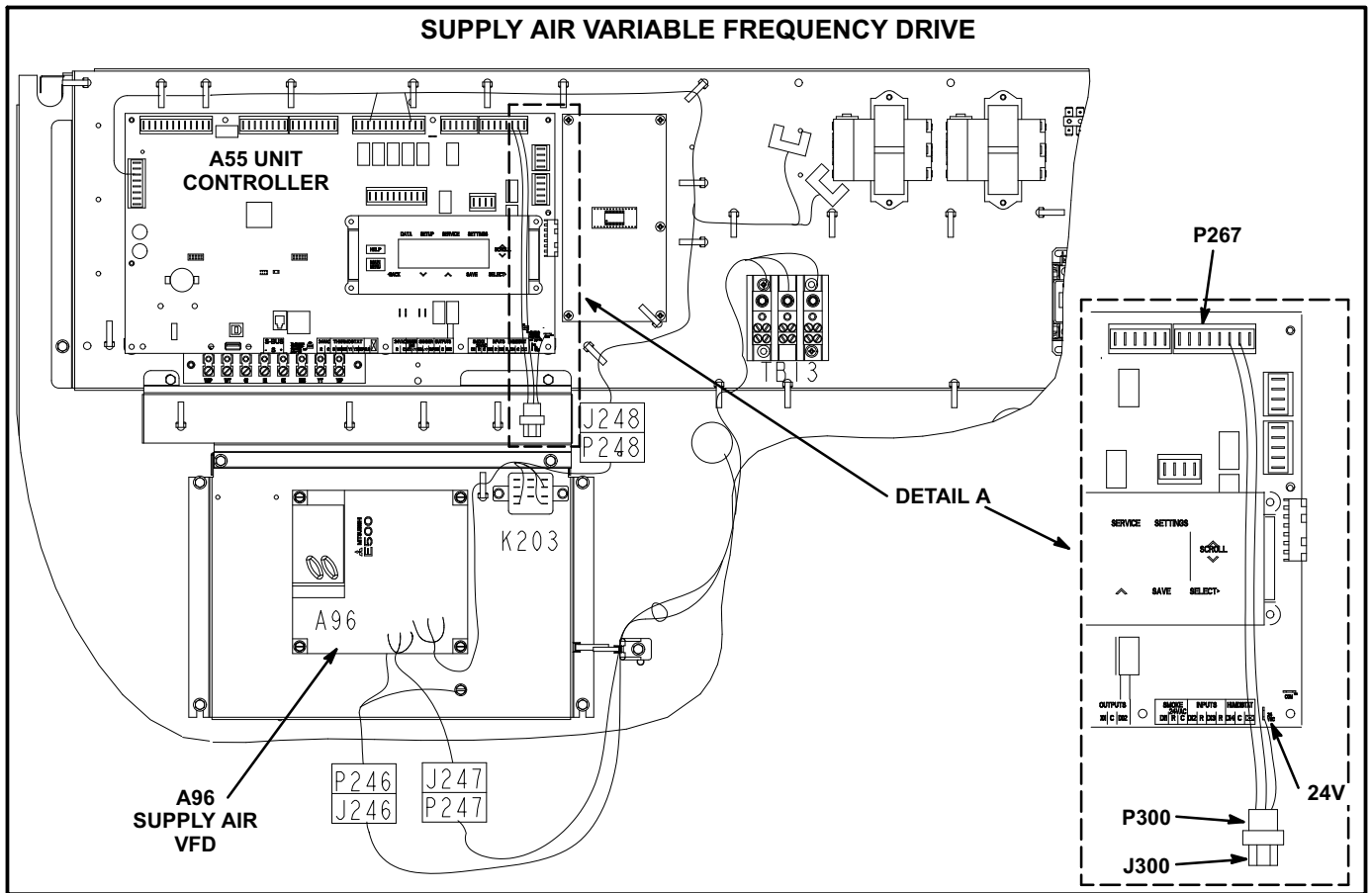


FIGURE 29



**FIGURE 30**

Note - The Unit Controller will lock-out the unit for 5 minutes if static pressure exceeds 2.0" w.c. for 20 seconds. The Unit Controller will permanently shut down the unit after three occurrences. See Unit Controller parameters 110, 42, and 43 to adjust default values.

8 If the desired CFM cannot be met with current pulley setup, refer to the *Blower Operation and Adjustments* section to adjust CFM.

**B-Unit Operation**

Use the Unit Controller to check unit mechanical operation. See the *Service - Test* section of the Unit Controller manual.

**TABLE 41  
RECORD ADJUSTED SETPOINTS**

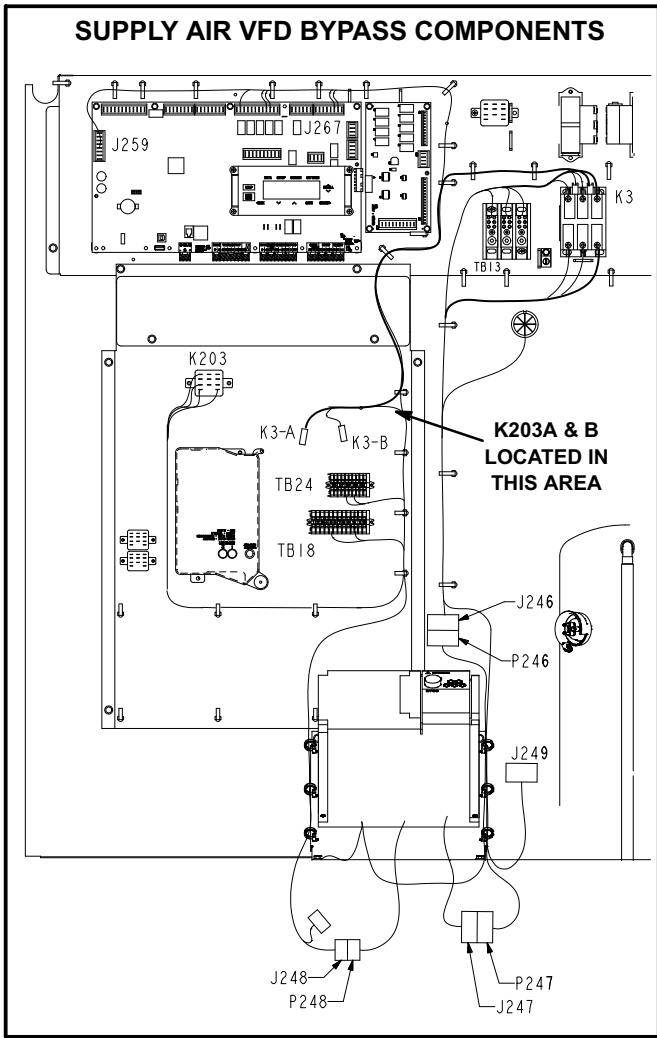
Parameter	Setpoint Description	Setpoint "w.c.	Display Setting
386	Smoke		
387	Ventilation		
388	Heating		
389	Cooling		

**C-Supply Air VFD Bypass (Optional)**

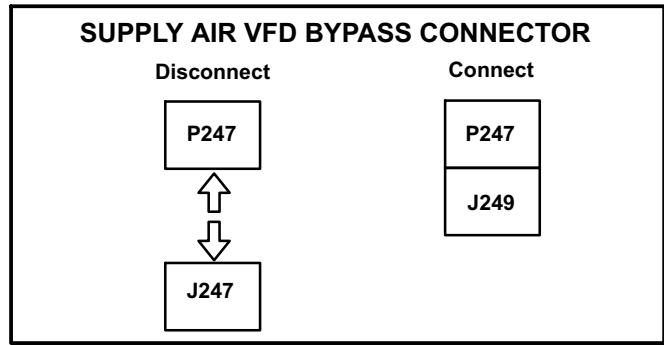
**IMPORTANT - All dampers must be open to prevent damage to duct work and dampers.**

1 Turn off all power to unit.

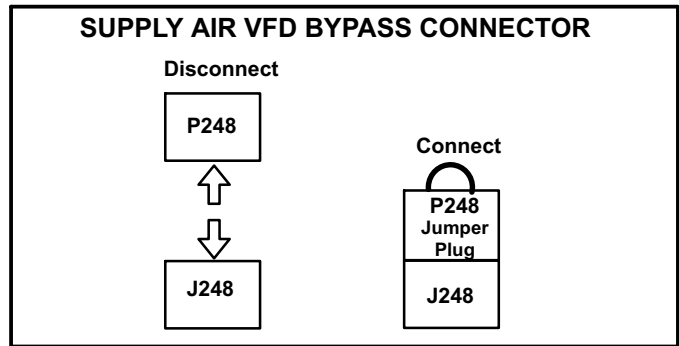
- 2 Locate J/P247 and J/P248 connectors near the VFD. See figure 31.
- 3 Disconnect P247 from J247 and connect J249 to P247. See figure 32.
- 4 Disconnect J248 from P248 and connect connect P248 jumper plug to J248. P248 jumper plug is attached to the J248 wire harness near the J248 jack connector. See figure 33.
- 5 Locate VFD control relay K203 on the lower control panel next to terminal strip TB24. See figure 31.
- 6 Locate wires labeled K203-A and K203-B in area shown in figure 31. Disconnect insulated terminals.
- 7 Locate wires labeled K3-A and K3-B coming from K3 blower relay. Connect to K203-A to K3-A and K203-B to K3-B.
- 8 Restore power to unit. Blower will operate in constant air volume (CAV) mode.
- 9 Check the indoor blower motor nameplate for full load amperage (FLA) value. Measure the amp readings from the indoor blower motor operating in bypass mode. If measured amps are higher than nameplate FLA value, decrease the CFM by opening (turning counterclockwise) the motor pulley. See figure 10. Do not exceed minimum and maximum number of pulley turns as shown in table 5.



**FIGURE 31**



**FIGURE 32**



**FIGURE 33**

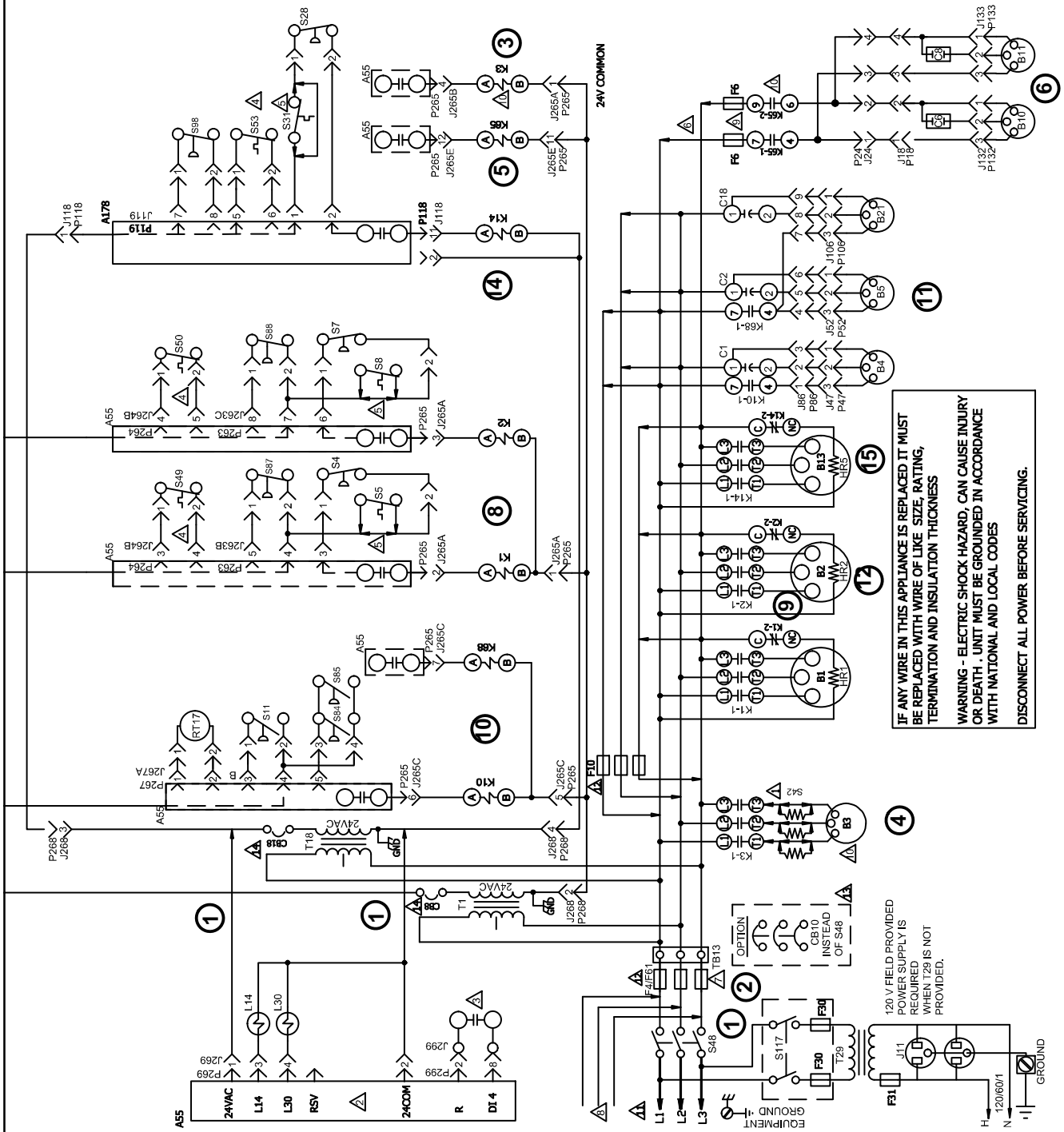


# LCH156 UNIT DIAGRAM

- △ S42 USED ON "M" VOLTAGE UNITS AND UNITS WITH HIGH EFFICIENCY MOTORS
- △ ONLY USED IN UNIT WITH HUMIDITROL OPTION
- △ EXTERNAL HUMIDITROL CONTACTS
- △ S49, S50 AND S53 ARE PART OF 5VDC CIRCUIT
- △ S5, S8, S31 USED ON UNITS WITH INTERLINK COMPRESSORS ONLY
- △ B10 AND B11 NOT USED ON UNITS WITH ERV
- △ USED ON LCH AND UNITS WITH ERV SINGLE POINT POWER. SEE ERV DIAGRAM
- △ USED ON UNITS WITH ERV SINGLE POINT POWER
- △ F6 USED ON Y-VOLT UNITS AND ALL SCOR OPTION UNITS WITH POWER EXHAUST
- △ REFER TO UNIT DIAGRAM SECTION B3 WHEN INVERTER IS USED
- △ NOTE: FOR USE WITH COPPER CONDUCTORS ONLY. REFER TO UNIT RATING PLATE FOR MINIMUM CIRCUIT AMPACITY AND MAXIMUM OVERCURRENT PROTECTION SIZE.
- △ F10 USED ON UNITS WITH SCOR OPTION. F61 USED ON LGH UNITS WITH SCOR OPTION
- △ CB10 NOT AVAILABLE ON UNITS WITH SCOR OPTION
- △ MOVE WIRE FROM 240 TO 208 TAP ON TRANSFORMER FOR 208 VOLT APPLICATIONS

— DENOTES OPTIONAL COMPONENTS  
 — LINE VOLTAGE FIELD INSTALLED

2018/08	537700-02	DIAGRAM	10/18
537700-02			
COOLING			
LCH/LGH - 156 - G, J, M, Y			
Supersedes		SECTION B	REV. 0
537700-02		New Form No.	537700-03



**IF ANY WIRE IN THIS APPLIANCE IS REPLACED IT MUST BE REPLACED WITH WIRE OF LIKE SIZE, RATING, TERMINATION AND INSULATION THICKNESS.**

**WARNING - ELECTRIC SHOCK HAZARD, CAN CAUSE INJURY OR DEATH. UNIT MUST BE GROUNDING IN ACCORDANCE WITH NATIONAL AND LOCAL CODES.**

**DISCONNECT ALL POWER BEFORE SERVICING.**

120 V FIELD PROVIDED POWER SUPPLY IS REQUIRED WHEN T29 IS NOT PROVIDED.

## LCH156 DIAGRAM KEY DESCRIPTION

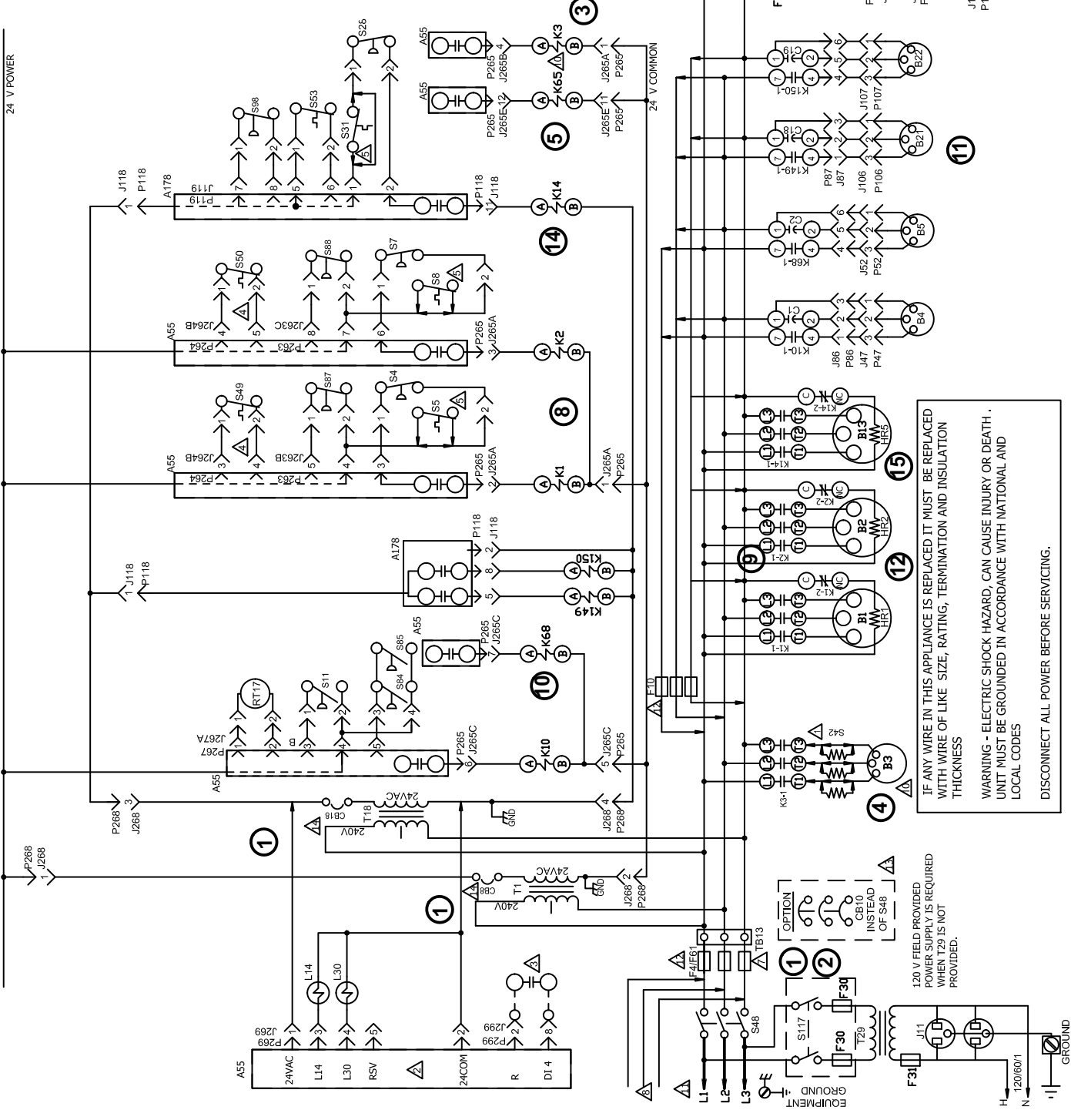
KEY	COMPONENT
A55	PANEL, MAIN BOARD LENNOX
A178	PANEL, COMP 3 & 4 AND 2ND STAGE HEAT - C3
B1	COMPRESSOR 1
B2	COMPRESSOR 2
B3	MOTOR, BLOWER
B4	MOTOR, OUTDOOR FAN 1
B5	MOTOR, OUTDOOR FAN 2
B10	MOTOR, EXHAUST FAN 1
B11	MOTOR, EXHAUST FAN 2
B13	COMPRESSOR 3
B21	MOTOR, OUTDOOR FAN 3
C1	CAPACITOR, OUTDOOR FAN 1
C2	CAPACITOR, OUTDOOR FAN 2
C6	CAPACITOR, EXHAUST FAN 1
C8	CAPACITOR, EXHAUST FAN 2
C18	CAPACITOR, OUTDOOR FAN 3
CB8	CIRCUIT, BREAKER T1
CB10	CIRCUIT BREAKER, MAIN DISCONNECT UNIT
CB18	CIRCUIT, BREAKER T18
F4	FUSE, MAIN UNIT
F6	FUSE, EXHAUST FAN
F10	FUSE, OUTDOOR FAN MOTOR
F30	FUSE, TRANSFORMER T29 PRIMARY
F31	FUSE, TRANSFORMER T29 SECONDARY
F61	FUSE, UNIT SCCR OPTION
HR1	HEATER COMPRESSOR 1
HR2	HEATER COMPRESSOR 2
HR5	HEATER COMPRESSOR 3
J11	JACK, GFI, RECEPTACLE
K1, -1	CONTACTOR, COMPRESSOR 1
K2, -1	CONTACTOR, COMPRESSOR 2
K3, -1	CONTACTOR, BLOWER
K10,-1,2	RELAY, OUTDOOR FAN 1
K14	CONTACTOR, COMPRESSOR 3
K65 - 1,2	RELAY, EXHAUST FAN
K68,-1	RELAY, OUTDOOR FAN 2
L14	VALVE, SOLENOID REHEAT VALVE 1
L30	VALVE, SOLENOID REHEAT VALVE 2
RT17	SENSOR, OUTDOOR AIR
S4	SWITCH, LIMIT HI PRESS COMPRESSOR 1
S5	SWITCH, LIMIT TEMP COMPRESSOR 1
S7	SWITCH, LIMIT HI PRESS COMPRESSOR 2
S8	SWITCH, LIMIT HI TEMP COMPRESSOR 2
S11	SWITCH, LOW PRESS, LOW AMBIENT COMP 1
S28	SWITCH, LIMIT HI PRESS COMPRESSOR 3
S31	SWITCH, LIMIT HI TEMP COMPRESSOR 3
S42	SWITCH, OVERLOAD RELAY BLOWER MOTOR
S48	SWITCH, DISCONNECT
S49	SWITCH, FREEZE STAT COMPRESS 1
S50	SWITCH, FREEZE STAT COMPRESS 2
S53	SWITCH, FREEZE STAT COMPRESS 3
S84	SWITCH, LOW PRESS, LOW AMBIENT COMP 2
S85	SWITCH, LOW PRESS, LOW AMBIENT COMP 3
S87	SWITCH, LOW PRESS, COMP 1
S88	SWITCH, LOW PRESS, COMP 2
S98	SWITCH, LOW PRESS, COMP 3
S117	SWITCH, GFI
T1	TRANSFORMER, CONTROL
T18	TRANSFORMER, CONTACTOR
T29	TRANSFORMER, GFI
TB13	TERMINAL STRIP, POWER DISTRIBUTION

J/P	JACK/PLUG DESCRIPTION
18	EXHAUST FAN COMP
24	EXHAUST FAN
47	OUTDOOR FAN 1
52	OUTDOOR FAN 2
86	OUTDOOR FAN INTERFACE
106	OUTDOOR FAN 3
118	COMPRESSOR 3 AND 4, CONTROL
119	COMPRESSOR 3 AND 4, INPUT
132	EXHAUST FAN MOTOR 1
133	EXHAUST FAN MOTOR 2
263	HIGH AND LOW PRESSURE SWITCHES
264	BLOWER DECK
265	CONTACTORS AND RELAYS
267	OUTDOOR FAN AREA
268	TRANSFORMER POWER
269	REHEAT CONTROL
299	HUMIDITROL SAFETY INTERFACE

# LCH180 UNIT DIAGRAM

- ▲ S42 USED ON "M" VOLTAGE UNITS
- ▲ ONLY IN UNITS WITH HUMIDITROL OPTION
- ▲ EXTERNAL HUMIDITROL CONTACTS
- ▲ S49 AND S50 ARE PART OF 5VDC CIRCUIT
- ▲ S5, S8, S31 USED ON UNITS WITH INTERLINK COMPRESSORS ONLY
- ▲ B10 AND B11 NOT USED ON UNITS WITH ERV
- ▲ USED ON LCH AND UNITS WITH ERV SINGLE POINT POWER. SEE ERV DIAGRAM
- ▲ USED ON UNITS WITH ERV SINGLE POINT POWER
- ▲ F6 ONLY USED ON Y-VOLT UNITS WITH FIELD INSTALLED POWER EXHAUST
- ▲ REFER TO UNIT DIAGRAM SECTION B3 WHEN INVERTER IS USED
- ▲ NOTE: FOR USE WITH COPPER CONDUCTORS ONLY. REFER TO UNIT RATING PLATE FOR MINIMUM CIRCUIT AMPACITY AND MAXIMUM OVERCURRENT PROTECTION SIZE.
- ▲ F10 USED ON UNITS WITH SCCR OPTION. F61 USED ON LGH UNITS WITH SCCR OPTION
- ▲ CB10 NOT AVAILABLE ON UNITS WITH SCCR OPTION
- ▲ MOVE WIRE FROM 240 TO 208 TAP ON TRANSFORMER FOR 208 VOLT APPLICATIONS
- ▲ DENOTES OPTIONAL COMPONENTS
- LINE VOLTAGE FIELD INSTALLED

WIRING DIAGRAM	09/18
537701-03	
COOLING	
LCH, LGH 180 - G, J, M, Y	
SECTION B	
New Form No.	537701-03
Supersedes	537701-02
REV: 0	



IF ANY WIRE IN THIS APPLIANCE IS REPLACED IT MUST BE REPLACED WITH WIRE OF LIKE SIZE, RATING, TERMINATION AND INSULATION THICKNESS

WARNING - ELECTRIC SHOCK HAZARD. CAN CAUSE INJURY OR DEATH. UNIT MUST BE GROUNDED IN ACCORDANCE WITH NATIONAL AND LOCAL CODES

DISCONNECT ALL POWER BEFORE SERVICING.

OPTION  
 CB10  
 INSTEAD  
 OF S46

120 V FIELD PROVIDED  
 POWER SUPPLY IS REQUIRED  
 WHEN T29 IS NOT  
 PROVIDED.

## LCH180 KEY DESCRIPTION

KEY	COMPONENT
A55	PANEL, MAIN
A178	PANEL, COMP 3 & 4 AND 2ND STAGE HEAT - C3
B1	COMPRESSOR 1
B2	COMPRESSOR 2
B3	MOTOR, BLOWER
B4	MOTOR, OUTDOOR FAN 1
B5	MOTOR, OUTDOOR FAN 2
B10	MOTOR, EXHAUST FAN 1
B11	MOTOR, EXHAUST FAN 2
B13	COMPRESSOR 3
B21	MOTOR, OUTDOOR FAN 3
B22	MOTOR, OUTDOOR FAN 4
C1	CAPACITOR, OUTDOOR FAN 1
C2	CAPACITOR, OUTDOOR FAN 2
C6	CAPACITOR, EXHAUST FAN 1
C8	CAPACITOR, EXHAUST FAN 2
C18	CAPACITOR, OUTDOOR FAN 3
C19	CAPACITOR, OUTDOOR FAN 4
CB8	CIRCUIT, BREAKER T1
CB10	CIRCUIT BREAKER, MAIN DISCONNECT UNIT
CB18	CIRCUIT, BREAKER T18
F4	FUSE, MAIN UNIT
F6	FUSE, EXHAUST FAN
F10	FUSE, OUTDOOR FAN MOTOR
F30	FUSE, TRANSFORMER T29 PRIMARY
F31	FUSE, TRANSFORMER T29 SECONDARY
F61	FUSE, UNIT SCOR OPTION
HR1	HEATER COMPRESSOR 1
HR2	HEATER COMPRESSOR 2
HR5	HEATER COMPRESSOR 3
J11	JACK, GFI, RECEPTACLE
K1,-1	CONTACTOR, COMPRESSOR 1
K2,-1	CONTACTOR, COMPRESSOR 2
K3,-1	CONTACTOR, BLOWER
K10,-1	RELAY, OUTDOOR FAN 1
K14,-1	CONTACTOR, COMPRESSOR 3
K65,-1,2	RELAY, EXHAUST FAN
K68,-1	RELAY, OUTDOOR FAN 2
K149,-1	RELAY, OUTDOOR FAN 3
K150,-1	RELAY, OUTDOOR FAN 4
L14	VALVE, SOLENOID REHEAT VALVE 1
L30	VALVE, SOLENOID REHEAT VALVE 2
RT17	SENSOR, OUTDOOR AIR
S4	SWITCH, LIMIT HI PRESS COMPRESS 1
S5	SWITCH, LIMIT HI TEMP COMPRESSOR 1
S7	SWITCH, LIMIT HI PRESS COMPRESS 2
S8	SWITCH, LIMIT HI TEMP COMPRESSOR 2
S11	SWITCH, LOW PRESS, LOW AMBIENT COMP 1
S28	SWITCH, LIMIT HI PRESS COMPRESS 3
S31	SWITCH, LIMIT HI TEMP COMPRESSOR 3
S42	SWITCH, OVERLOAD RELAY BLOWER MOTOR

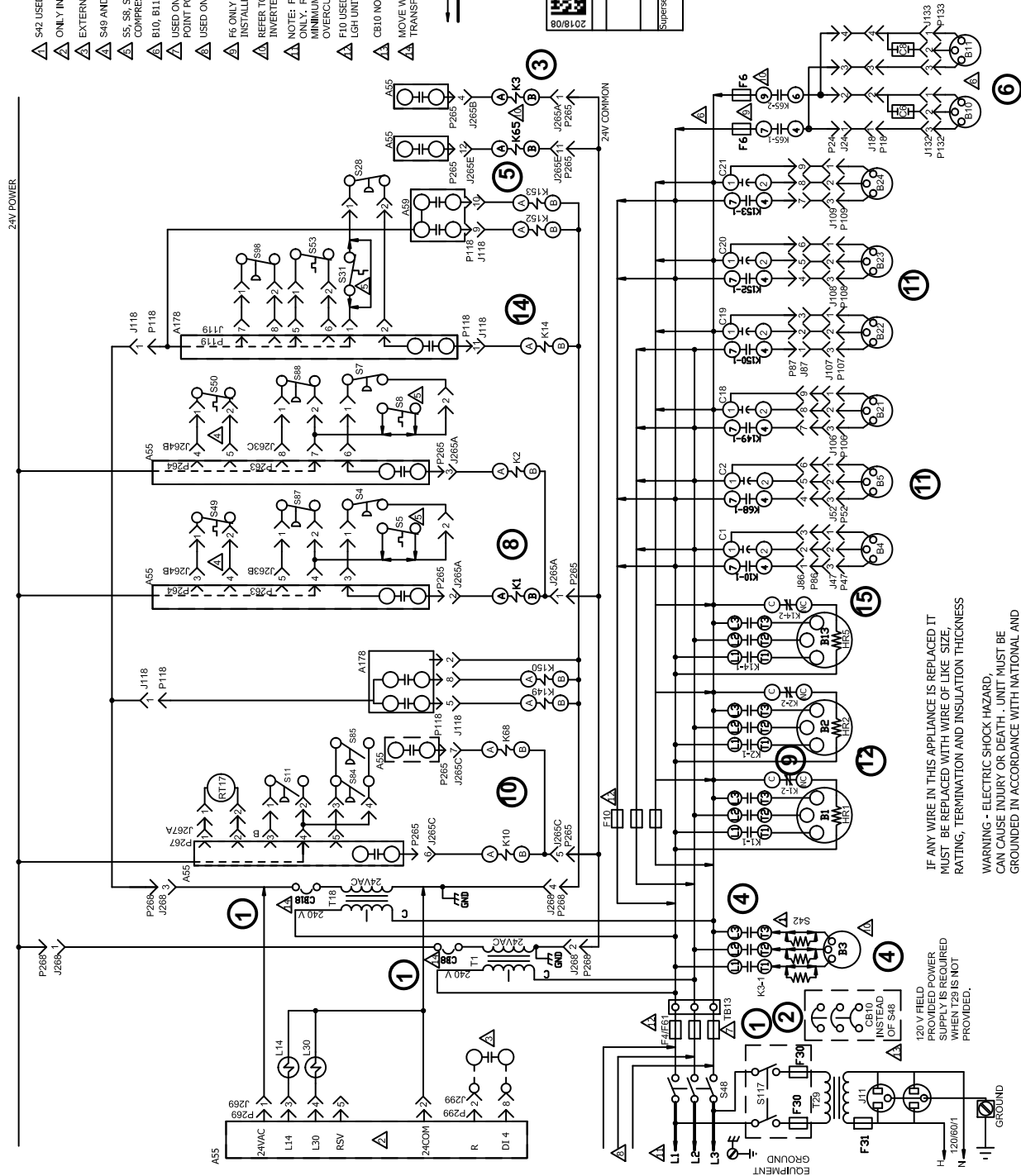
S48	SWITCH, DISCONNECT
S49	SWITCH, FREEZE STAT COMPRESS 1
S50	SWITCH, FREEZE STAT COMPRESS 2
S53	SWITCH, FREEZE STAT COMPRESS 3
S84	SWITCH, LOW PRESS, LOW AMBIENT COMP 2
S85	SWITCH, LOW PRESS, LOW AMBIENT COMP 3
S87	SWITCH, LOW PRESS, COMP 1
S88	SWITCH, LOW PRESS, COMP 2
S98	SWITCH, LOW PRESS, COMP 3
S117	SWITCH, GFI
T1	TRANSFORMER, CONTROL
T18	TRANSFORMER, CONTACTOR
T29	TRANSFORMER, GFI
TB13	TERMINAL STRIP, POWER DISTRIBUTION

J/P	JACK/PLUG DESCRIPTION
18	EXHAUST FAN COMP
24	EXHAUST FAN
47	OUTDOOR FAN 1
52	OUTDOOR FAN 2
86	OUTDOOR FAN INTERFACE 1
87	OUTDOOR FAN INTERFACE 2
106	OUTDOOR FAN 3
107	OUTDOOR FAN 4
118	COMPRESSOR 3 AND 4, CONTROL
119	COMPRESSOR 3 AND 4, INPUT
132	EXHAUST FAN MOTOR 1
133	EXHAUST FAN MOTOR 2
263	HIGH AND LOW PRESSURE SWITCHES
264	BLOWER DECK
265	CONTACTORS AND RELAYS
267	OUTDOOR FAN AREA
268	TRANSFORMER POWER
269	REHEAT CONTROL
299	HUMIDITROL INTERFACE/SAFETY

# LCH210 UNIT DIAGRAM

- ▲ S42 USED ON "M" VOLTAGE UNITS
- ▲ ONLY IN UNITS WITH HUMIDITROL OPTION
- ▲ EXTERNAL HUMIDITROL CONTACTS
- ▲ S49 AND S50 ARE PART OF 5VDC CIRCUIT COMPRESSORS ONLY
- ▲ S5, S8, S31 USED ON UNITS WITH INTERLINK
- ▲ B10, B11 NOT USED ON UNITS WITH ERV
- ▲ USED ON LCH AND UNITS WITH ERV SINGLE POINT POWER. SEE ERV DIAGRAM
- ▲ USED ON UNITS WITH ERV SINGLE POINT POWER
- ▲ F6 ONLY USED ON VOLT. UNITS WITH FIELD INSTALLED POWER EXHAUST
- ▲ REFER TO UNIT DIAGRAM SECTION B3 WHEN INVERTER IS USED
- ▲ NOTE: FOR USE WITH COPPER CONDUCTORS MINIMUM CIRCUIT AMPACITY AND MAXIMUM OVERCURRENT PROTECTION SIZE.
- ▲ F10 USED ON UNITS WITH SCOR OPTION; F61 USED ON LGH UNITS WITH SCOR OPTION
- ▲ C610 NOT AVAILABLE ON UNITS WITH SCOR OPTION
- ▲ MOVE WIRE FROM 240 TO 208 TAP ON TRANSFORMER FOR 208-VOLT APPLICATIONS
- DENOTES OPTIONAL COMPONENTS
- LINE VOLTAGE FIELD INSTALLED

2018/08	08/18
WIRING DIAGRAM	537702-03
COOLING	
LCH, LGH - 210 G, J, Y	
Supersedes:	SECTION B
537702-02	New Form No. 537702-03
	REV. 0



IF ANY WIRE IN THIS APPLIANCE IS REPLACED IT MUST BE REPLACED WITH WIRE OF LIKE SIZE, RATING, TERMINATION AND INSULATION THICKNESS.

WARNING - ELECTRIC SHOCK HAZARD. CAN CAUSE INJURY OR DEATH - UNIT MUST BE GROUNDED IN ACCORDANCE WITH NATIONAL AND LOCAL CODES.

DISCONNECT ALL POWER BEFORE SERVICING.

130 V FIELD PROVIDED POWER SUPPLY IS REQUIRED WHEN T29 IS NOT PROVIDED.

## LCH210 KEY DESCRIPTION

KEY	COMPONENT
A55	PANEL, MAIN
A178	PANEL, COMP 3 & 4 AND 2ND STAGE HEAT - C3
B1	COMPRESSOR 1
B2	COMPRESSOR 2
B3	MOTOR, BLOWER
B4	MOTOR, OUTDOOR FAN 1
B5	MOTOR, OUTDOOR FAN 2
B10	MOTOR, EXHAUST FAN 1
B11	MOTOR, EXHAUST FAN 2
B13	COMPRESSOR 3
B21	MOTOR, OUTDOOR FAN 3
B22	MOTOR, OUTDOOR FAN 4
B23	MOTOR, OUTDOOR FAN 5
B24	MOTOR, OUTDOOR FAN 6
C1	CAPACITOR, OUTDOOR FAN 1
C2	CAPACITOR, OUTDOOR FAN 2
C6	CAPACITOR, EXHAUST FAN 1
C8	CAPACITOR, EXHAUST FAN 2
C18	CAPACITOR, OUTDOOR FAN 3
C19	CAPACITOR, OUTDOOR FAN 4
C20	CAPACITOR, OUTDOOR FAN 5
C21	CAPACITOR, OUTDOOR FAN 6
CB8	CIRCUIT, BREAKER T1
CB10	CIRCUIT BREAKER, MAIN DISCONNECT UNIT
CB18	CIRCUIT, BREAKER T18
F4	FUSE, MAIN UNIT
F6	FUSE, EXHAUST FAN
F10	FUSE, OUTDOOR FAN MOTOR
F30	FUSE, TRANSFORMER T29 PRIMARY
F31	FUSE, TRANSFORMER T29 SECONDARY
F61	FUSE, UNIT SCOR OPTION
HR1	HEATER COMPRESSOR 1
HR2	HEATER COMPRESSOR 2
HR5	HEATER COMPRESSOR 3
J11	JACK, GFI, RECEPTACLE
K1,-1	CONTACTOR, COMPRESSOR 1
K2,-1	CONTACTOR, COMPRESSOR 2
K3,-1	CONTACTOR, BLOWER
K10,-1	RELAY, OUTDOOR FAN 1
K14,-1	CONTACTOR, COMPRESSOR 3
K65-1,2	RELAY, EXHAUST FAN
K68,-1	RELAY, OUTDOOR FAN 2
K149,-1	RELAY, OUTDOOR FAN 3
K150,-1	RELAY, OUTDOOR FAN 4
K152,-1	RELAY, OUTDOOR FAN 5
K153,-1	RELAY, OUTDOOR FAN 6
L14	VALVE, SOLENOID REHEAT COIL 1
L30	VALVE, SOLENOID REHEAT COIL 2
RT17	SENSOR, OUTDOOR AIR
S4	SWITCH, LIMIT HI PRESS COMPRESS 1
S5	SWITCH, LIMIT HI TEMP COMPRESSOR 1
S7	SWITCH, LIMIT HI PRESS COMPRESS 2
S8	SWITCH, LIMIT HI TEMP COMPRESSOR 2
S11	SWITCH, LOW PRESS, LOW AMBIENT KIT COMP 1
S28	SWITCH, LIMIT HI PRESS COMPRESS 3
S31	SWITCH, LIMIT HI TEMP COMPRESSOR 3
S42	SWITCH, OVERLOAD RELAY BLOWER MOTOR
S48	SWITCH, DISCONNECT
S49	SWITCH, FREEZE STAT COMPRESS 1
S50	SWITCH, FREEZE STAT COMPRESS 2

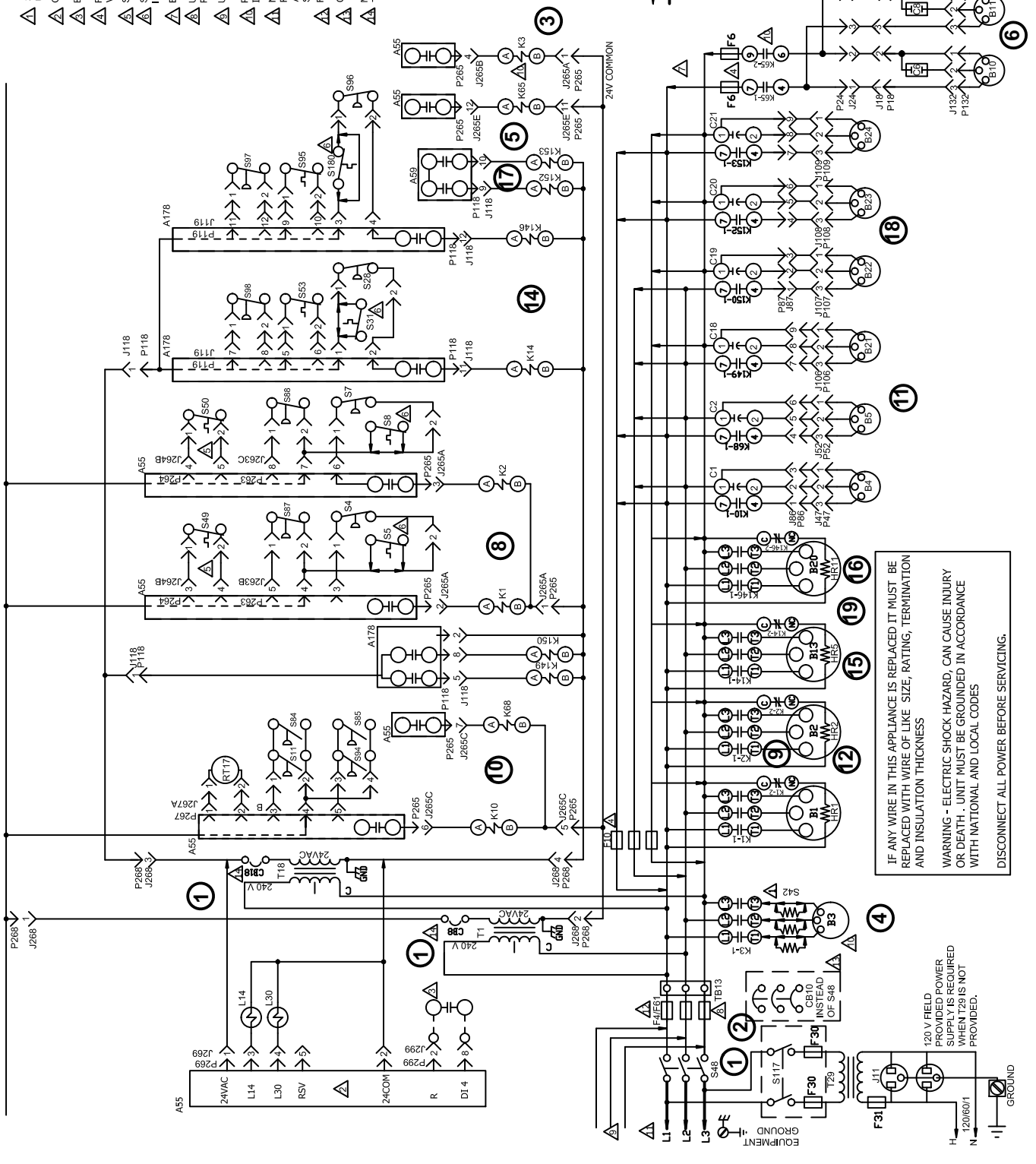
S53	SWITCH, FREEZE STAT COMPRESS 3
S84	SWITCH, LOW PRESS, LOW AMBIENT KIT COMP 2
S85	SWITCH, LOW PRESS, LOW AMBIENT KIT COMP 3
S87	SWITCH, LOW PRESS, COMP 1
S88	SWITCH, LOW PRESS, COMP 2
S98	SWITCH, LOW PRESS, COMP 3
S117	SWITCH, GFI
T1	TRANSFORMER, CONTROL
T18	TRANSFORMER, CONTACTOR
T29	TRANSFORMER, GFI
TB13	TERMINAL STRIP, POWER DISTRIBUTION

J/P	JACK/PLUG DESCRIPTION
18	EXHAUST FAN COMP
24	EXHAUST FAN
47	OUTDOOR FAN 1
52	OUTDOOR FAN 2
86	OUTDOOR FAN INTERFACE
87	OUTDOOR FAN INTERFACE 2
106	OUTDOOR FAN 3
107	OUTDOOR FAN 4
108	OUTDOOR FAN 5
109	OUTDOOR FAN 6
118	COMPRESSOR 3 AND 4, CONTROL
119	COMPRESSOR 3 AND 4, INPUT
132	EXHAUST FAN MOTOR 1
133	EXHAUST FAN MOTOR 2
263	HIGH AND LOW PRESSURE SWITCHES
264	BLOWER DECK
265	CONTACTORS AND RELAYS
267	OUTDOOR FAN AREA
268	TRANSFORMER POWER
269	HUMIDITROL POWER/CONTROL
299	HUMIDITROL INTERFACE/SAFETY

# LCH240/300 UNIT DIAGRAM

- △ S42 USED ON "M" VOLTAGE UNITS AND UNITS WITH 10HP MOTORS
- △ ONLY ON UNITS WITH HUMIDITROL OPTION
- △ EXTERNAL HUMIDITROL CONTACTS
- △ F6 AND F10 FUSES ARE USED ON "Y" VOLTAGE UNITS AND SCCR OPTION UNITS
- △ S49 AND S50 ARE PART OF 5VDC CIRCUIT
- △ S5, S8, S31, S180 USED ON UNITS WITH INTERLINK COMPRESSORS ONLY
- △ B10, B11 NOT USED ON UNITS WITH ERV
- △ USED ON LCH AND UNITS WITH ERV SINGLE POINT POWER. SEE ERV DIAGRAM
- △ USED ON UNITS WITH ERV SINGLE POINT POWER
- △ REFER TO UNIT DIAGRAM SECTION B3 WHEN INVERTER IS USED
- △ NOTE: FOR USE WITH COPPER CONDUCTORS ONLY. REFER TO UNIT RATING PLATE FOR MINIMUM CIRCUIT AMPACITY AND MAXIMUM OVERCURRENT PROTECTION SIZE.
- △ F61 USED ON ALL UNITS WITH LGH UNITS SCCR OPTION
- △ CB10 NOT AVAILABLE ON UNITS WITH SCCR OPTION
- △ MOVE WIRE FROM 240 TO 208 TAP ON TRANSFORMER FOR 208 VOLT APPLICATIONS

08/18	WIRING DIAGRAM
537703-03	537703-03
COOLING	
LCH, LGH + 240, 300 - G, J, M, Y	
SECTION B	REV. 0
Supersedes	New Form No. 537703-02



— DENOTES OPTIONAL COMPONENTS  
 — LINE VOLTAGE FIELD INSTALLED

IF ANY WIRE IN THIS APPLIANCE IS REPLACED IT MUST BE REPLACED WITH WIRE OF LIKE SIZE, RATING, TERMINATION AND INSULATION THICKNESS

WARNING - ELECTRIC SHOCK HAZARD, CAN CAUSE INJURY OR DEATH. UNIT MUST BE GROUNDED IN ACCORDANCE WITH NATIONAL AND LOCAL CODES

DISCONNECT ALL POWER BEFORE SERVICING.

120V FIELD PROVIDED POWER SUPPLY IS REQUIRED WHEN T29 IS NOT PROVIDED.

## LCH240/300 KEY DESCRIPTION

KEY	COMPONENT
A55	MAIN CONTROL BOARD
A178	PANEL, COMP 3 & 4 AND STAGE HEAT - C3
B1	COMPRESSOR 1
B2	COMPRESSOR 2
B3	MOTOR, BLOWER
B4	MOTOR, OUTDOOR FAN 1
B5	MOTOR, OUTDOOR FAN 2
B10	MOTOR, EXHAUST FAN 1
B11	MOTOR, EXHAUST FAN 2
B13	COMPRESSOR 3
B20	COMPRESSOR 4
B21	MOTOR, OUTDOOR FAN 3
B22	MOTOR, OUTDOOR FAN 4
B23	MOTOR, OUTDOOR FAN 5
B24	MOTOR, OUTDOOR FAN 6
C1	CAPACITOR, OUTDOOR FAN 1
C2	CAPACITOR, OUTDOOR FAN 2
C6	CAPACITOR, EXHAUST FAN 1
C8	CAPACITOR, EXHAUST FAN 2
C18	CAPACITOR, OUTDOOR FAN 3
C19	CAPACITOR, OUTDOOR FAN 4
C20	CAPACITOR, OUTDOOR FAN 5
C21	CAPACITOR, OUTDOOR FAN 6
CB8	CIRCUIT, BREAKER T1
CB10	CIRCUIT BREAKER, MAIN DISCONNECT UNIT
CB18	CIRCUIT, BREAKER T18
F4	FUSE, MAIN UNIT
F6	FUSE, EXHAUST FAN
F10	FUSE, OUTDOOR FAN MOTOR
F30	FUSE, TRANSFORMER T29 PRIMARY
F31	FUSE, TRANSFORMER T29 SECONDARY
F61	FUSE, UNIT SCCR OPTION
HR1	HEATER COMPRESSOR 1
HR2	HEATER COMPRESSOR 2
HR5	HEATER COMPRESSOR 3
HR11	HEATER COMPRESSOR 4
J11	JACK, GFI, RECEPTACLE
K1, -1	CONTACTOR, COMPRESSOR 1
K2, -1	CONTACTOR, COMPRESSOR 2
K3, -1	CONTACTOR, BLOWER
K10,-1,2	RELAY, OUTDOOR FAN 1
K14, -1	CONTACTOR, COMPRESSOR 3
K65-1,2	RELAY, EXHAUST FAN
K68,-1	RELAY, OUTDOOR FAN 2
K146,-1	CONTACTOR, COMPRESSOR 4
K149,-1	RELAY, OUTDOOR FAN 3
K150,-1	RELAY, OUTDOOR FAN 4
K152,-1	RELAY, OUTDOOR FAN 5
K153,-1,2	RELAY, OUTDOOR FAN 6
L14	VALVE, SOLENOID REHEAT COIL 1
L30	VALVE, SOLENOID REHEAT COIL 2
RT17	SENSOR, OUTDOOR AIR
S4	SWITCH, LIMIT HI PRESS COMPRESS 1
S5	SWITCH, LIMIT HI TEMP COMPRESSOR 1
S7	SWITCH, LIMIT HI PRESS COMPRESS 2
S8	SWITCH, LIMIT HI TEMP COMPRESSOR 2
S11	SWITCH, LOW PRESS, LOW AMBIENT COMP 1
S28	SWITCH, LIMIT HI PRESS COMPRESS 3
S31	SWITCH, LIMIT HI TEMP COMPRESSOR 3
S42	SWITCH, OVERLOAD RELAY BLOWER MOTOR
S48	SWITCH, DISCONNECT

S49	SWITCH, FREEZE STAT COMPRESS 1
S50	SWITCH, FREEZE STAT COMPRESS 2
S53	SWITCH, FREEZE STAT COMPRESS 3
S84	SWITCH, LOW PRESS, LOW AMBIENT KIT COMP 2
S85	SWITCH, LOW PRESS, LOW AMBIENT KIT COMP 3
S87	SWITCH, LOW PRESS, COMP 1
S88	SWITCH, LOW PRESS, COMP 2
S94	SWITCH, LOW PRESS, LOW AMBIENT KIT COMP 4
S95	SWITCH, FREEZE STAT COMPRESS 4
S96	SWITCH, LIMIT HI PRESS COMPRESS 4
S97	SWITCH, LOW PRESS, COMP 4
S98	SWITCH, LOW PRESS, COMP 3
S117	SWITCH, GFI
S180	SWITCH, LIMIT HI TEMP COMPRESSOR 4
T1	TRANSFORMER, CONTROL
T18	TRANSFORMER, CONTACTOR
T29	TRANSFORMER, GFI
TB13	TERMINAL STRIP, POWER DISTRIBUTION

J/P	JACK/PLUG DESCRIPTION
18	POWER EXHAUST HARNESS
24	RELAY TO EXHAUST FANS
47	POWER TO OUTDOOR FAN 1
52	POWER TO OUTDOOR FAN 2
86	OUTDOOR FAN INTERFACE
87	OUTDOOR FAN INTERFACE 2
106	POWER TO OUTDOOR FAN 3
107	POWER TO OUTDOOR FAN 4
108	POWER TO OUTDOOR FAN 5
109	POWER TO OUTDOOR FAN 6
118	COMPRESSOR 3 AND 4, CONTROL
119	COMPRESSOR 3 AND 4, INPUT
132	POWER TO EXHAUST FAN MOTOR 1
133	POWER TO EXHAUST FAN MOTOR 2
263	HIGH AND LOW PRESSURE SWITCHES
264	BLOWER DECK
265	CONTACTORS AND RELAYS
267	OUTDOOR FAN AREA
268	24V POWER FROM TRANSFORMERS TO A55
269	HUMIDITROL
299	HUMIDITROL INTERFACE TO A55



## Sequence of Operation 156H / 300S

### POWER:

1. Line voltage from TB2, unit disconnect S48, or other factory or field installed optional power disconnects, such as CB10, energizes transformer T1 and T18. Transformer T1 provides 24VAC power to the A55 Unit Controller and T18 provides 24VAC power to A59 Compressor 3 and 4 Controller. The two controllers provide 24VAC power to the unit cooling, heating and blower controls and thermostat.
2. Terminal block TB13 is also energized when the unit disconnect closes. TB13 supplies line voltage to compressor crankcase heaters, compressors, blower motors and fan motors.

### BLOWER OPERATION (OCP INPUT MUST BE ON):

3. The A55 Unit Controller receives a demand from thermostat terminal G. A55 energizes blower contactor K3 with 24VAC.
4. N.O. K3-1 closes, energizing blower B3.

### ECONOMIZER OPERATION:

5. The A55 Unit Controller receives a demand and energizes exhaust fan relay K65 with 24VAC at 50% (travel) outside air damper open (adjustable).
6. N.O. K65-1 and K65-2 both close, energizing exhaust fan motors B10 and B11.

### 1ST STAGE COOLING (BOTH COMPRESSORS B1 AND B2 ARE ENERGIZED):

7. First stage cooling demand energizes Y1 and G in the thermostat. G energizes blower, if blower is not already running (see step 3).
8. 24VAC is routed to the A55 Unit Controller. After A55 proves N.C. low pressure switch S87 and S88, N.C. freezestat S49 and S50 and N.C. high pressure switch S4 and S7, compressor contactors K1 and K2 are energized.
9. N.O. contacts K1-1 and K2-1 close energizing compressor B1 and B2.

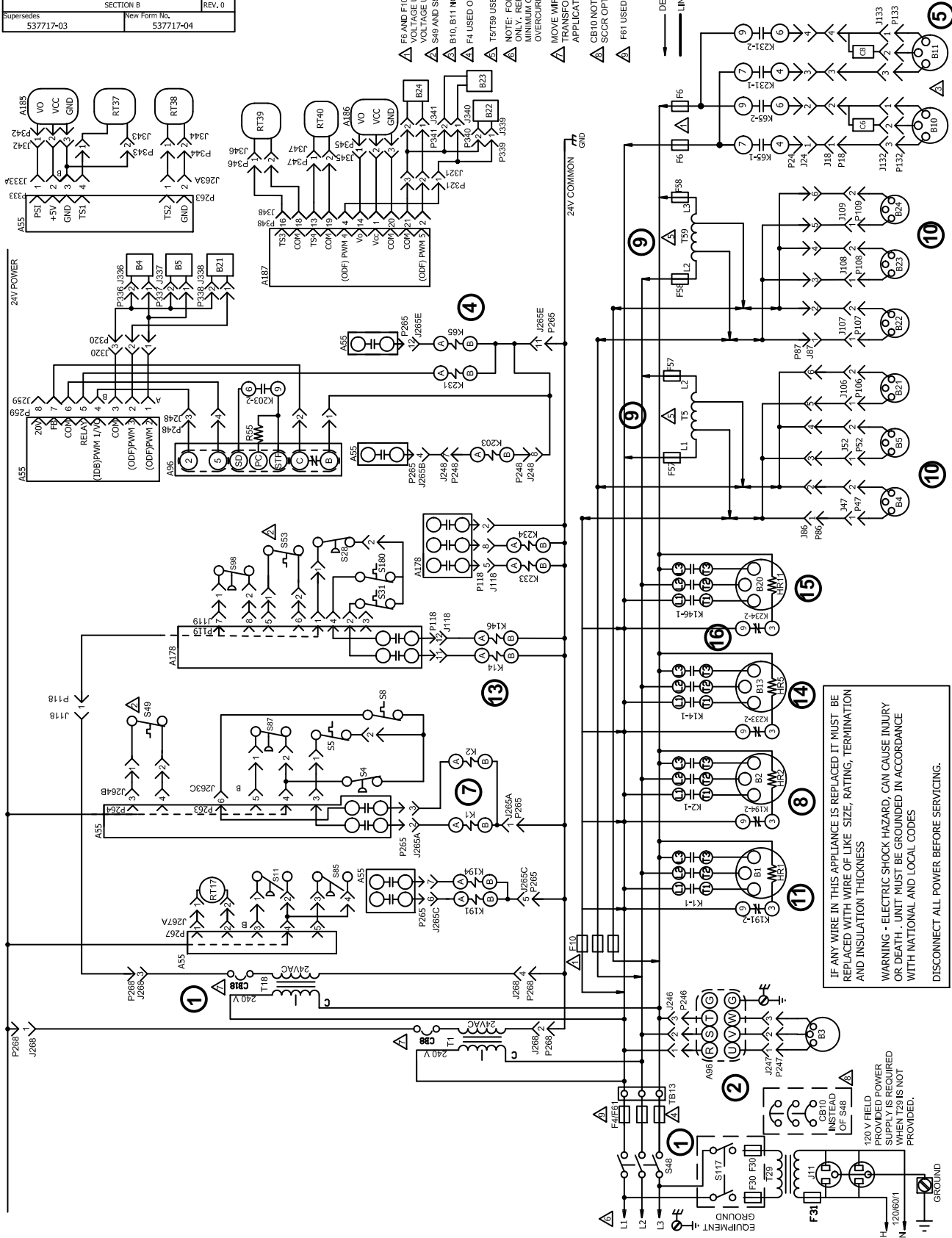
10. A55 Unit Controller and A59 Compressor 3 and 4 Controller energize fan contactor K10 (all units), K68 (all units), K149 (180H-300S only), K150 (180/210H only), K152 (210H only), K153 (210H only) based on low ambient switch S11 and S84 inputs and predefined control logic.
11. N.O. contact K10-1 (all units), K68-1 (all units), K149-1 (180H-300S only), K150-1 (180H/210H only), K152-1 (210H only), K153-1 (210H only) close energizing fan B4 (all units), B5 (all units), B21 (all units), B22 (180H/210H only), B23 (210H only), B24 (210H only).
12. Relay contacts K10-1 (210H), K10-2 (156H, 240H, 300S) or K68-1 (180H) open de-energizing compressor 1, 2 and 3 crankcase heater HR1 (all units), HR2 (all units) and HR5 (156H-210H only).

### 2ND STAGE COOLING (B13 IN 156H-210H AND BOTH B13 AND B20 IN 240H AND 300S ARE ENERGIZED):

13. Second stage cooling demand energizes Y2.
14. 24VAC is routed to A59 Compressor 3 and 4 Controller. After A59 proves N.C. low pressure switches S98 and S97, N.C. freezestats S53 and S95 and N.C. high pressure switches S28 and S96, compressor contactors K14 and K146 are energized.  
*NOTE: LCH156-210 units will be equipped with S98, S53, S28 and K14 only.*
15. N.O. contacts K14-1 close energizing compressor B13.
16. N.O. contacts K146-1 close energizing compressor B20 (LCH240/300 only).
17. A59 Compressor 3 and 4 Controller energizes fan contactor K150, K152, K153 (240H/300S only) based on low ambient switch S85 and S94 inputs and predefined Controller logic.
18. N.O. contacts K150-1, K152-1 and K153-1 (240H/300S only) close energizing condenser fan B22, B23 and B24 (240H/300S only).
19. N.C. contacts K153-2 (240H/300S only) open de-energizing compressor 3 and 4 crankcase heater HR5 and HR11 (240/300S only).

# LCH180U/240U/300U UNIT DIAGRAM

201605	WIRING DIAGRAM	05/19
537717-04		
COOLING -MSAV NO BYPASS		
LCH/LGH - 180, 240, 300 ULTRA - G, J, Y		
SECTION B		REV. 0
Supersedes	New Form No.	
537717-03	537717-04	



- △ F6 AND F10 FUSES ARE USED ON ALL "V" VOLTAGE UNITS AND SCOR OPTION G & J VOLTAGE UNITS
- △ S49 AND S53 ARE PART OF 5VDC CIRCUIT
- △ B10, B11 NOT USED ON UNITS WITH ERV
- △ F4 USED ON LCH UNITS
- △ T9T89 USED ON ALL G & J VOLTAGE
- △ NOTE: FOR USE WITH COPPER CONDUCTORS ONLY. REFER TO UNIT RATING PLATE FOR MINIMUM CIRCUIT AMPACITY AND MAXIMUM OVERCURRENT PROTECTION SIZE.
- △ MOVE WIRE FROM 240 TO 208 TAP ON TRANSFORMER FOR 208 VOLT APPLICATIONS
- △ CB10 NOT AVAILABLE ON UNITS WITH SCOR OPTION
- △ F81 USED ON LGH UNITS SCOR OPTION

- DENOTES OPTIONAL COMPONENTS
- LINE VOLTAGE FIELD INSTALLED

IF ANY WIRE IN THIS APPLIANCE IS REPLACED IT MUST BE REPLACED WITH WIRE OF LIKE SIZE, RATING, TERMINATION AND INSULATION THICKNESS

WARNING - ELECTRIC SHOCK HAZARD. CAN CAUSE INJURY OR DEATH - UNIT MUST BE GROUNDED IN ACCORDANCE WITH NATIONAL AND LOCAL CODES

DISCONNECT ALL POWER BEFORE SERVICING.

## LCH180U/240U/300U KEY DESCRIPTION

J/P	JACK/PLUG DESCRIPTION
18	POWER EXHAUST HARNESS
24	RELAY TO EXHAUST FANS
47	MOTOR, OUTDOOR FAN 1
52	MOTOR, OUTDOOR FAN 2
86	OUTDOOR FANS 1
87	OUTDOOR FANS 2
106	MOTOR, OUTDOOR FAN 3
107	MOTOR, OUTDOOR FAN 4
108	MOTOR, OUTDOOR FAN 5
109	MOTOR, OUTDOOR FAN 6
118	COMPRESSOR 3 AND 4, CONTROL A178
119	COMPRESSOR 3 AND 4, INPUT
132	POWER TO EXHAUST FAN MOTOR 1
133	POWER TO EXHAUST FAN MOTOR 2
246	POWER TO VFD
247	VFD TO MTR
248	VFD CONTROL
259	BLOWER ECM MOTOR
263	HIGH AND LOW PRESSURE SWITCHES
264	BLOWER DECK AREA
265	CONTACTORS AND RELAYS
267	OUTDOOR FAN AREA
268	24V POWER FROM TRANSFORMERS TO A55
320	OD FAN CONTROL SET 1
321	OD FAN CONTROL SET 2
333	0-5V TRANSDUCER INPUT
336	OD FAN CONTROL, B4
337	OD FAN CONTROL, B5
338	OD FAN CONTROL, B21
339	OD FAN CONTROL, B22
340	OD FAN CONTROL, B23
341	OD FAN CONTROL, B24
342	COMPRESSOR PRESSURE TRANSDUCER STG 1
343	TEMPERATURE SENSOR COMPRESSOR 1
344	TEMPERATURE SENSOR COMPRESSOR 2
345	COMPRESSOR PRESSURE TRANSDUCER STG 2
346	TEMPERATURE SENSOR COMPRESSOR 3
347	TEMPERATURE SENSOR COMPRESSOR 4
348	CONTROL GENERAL PURPOSE GP3

KEY	COMPONENT
A55	MAIN CONTROL BOARD
A96	CONTROL INVERTER
A178	PANEL, COMP 3&4, C3 2nd STAGE HEAT
A185	TRANSDUCER TANDEM COMPRESSOR STG 1
A186	TRANSDUCER TANDEM COMPRESSOR STG 2
A187	CONTROL GENERAL PURPOSE GP3
B1	COMPRESSOR 1
B2	COMPRESSOR 2
B3	MOTOR, BLOWER
B4	MOTOR, OUTDOOR FAN 1
B5	MOTOR, OUTDOOR FAN 2
B10	MOTOR, EXHAUST FAN 1
B11	MOTOR, EXHAUST FAN 2
B13	COMPRESSOR 3
B20	COMPRESSOR 4
B21	MOTOR, OUTDOOR FAN 3
B22	MOTOR, OUTDOOR FAN 4
B23	MOTOR, OUTDOOR FAN 5
B24	MOTOR, OUTDOOR FAN 6
C6	CAPACITOR, EXHAUST FAN 1
C8	CAPACITOR, EXHAUST FAN 2
CB8	CIRCUIT, BREAKER T1
CB10	CIRCUIT BREAKER, MAIN DISCONNECT UNIT
CB18	CIRCUIT, BREAKER T18
F4	FUSE, MAIN UNIT
F6	FUSE, EXHAUST FAN
F10	FUSE, OUTDOOR FAN MOTOR
F30	FUSE, TRANSFORMER T29 PRIMARY
F31	FUSE, TRANSFORMER T29 SECONDARY
F57	FUSE, TRANSFORMER T5 PRIMARY
F58	FUSE, TRANSFORMER T59 PRIMARY
F61	FUSE, UNIT SCCR OPTION
HR1	HEATER COMPRESSOR 1
HR2	HEATER COMPRESSOR 2
HR5	HEATER COMPRESSOR 3
HR11	HEATER 1, COMPRESSOR 4
J11	JACK, GFI, RECEPTACLE
K1, -1	CONTACTOR, COMPRESSOR 1
K2, -1	CONTACTOR, COMPRESSOR 2
K3-1	RELAY-CONTACTOR, BLOWER
K14, -1	CONTACTOR, COMPRESSOR 3
K65-1,2	RELAY, EXHAUST FAN
K146-1	CONTACTOR, COMPRESSOR 4
K191-2	RELAY, CRANKCASE HEATER 1
K194-2	RELAY, CRANKCASE HEATER 2
K202-1	RELAY, INVERTER
K203-2	RELAY, CONTROL INVERTER
K231-1,2	RELAY, EXHAUST FAN 2
K233-2	RELAY, CRANKCASE HEATER 3
K234-2	RELAY, CRANKCASE HEATER 4
R55	RESISTOR, VFD LOADING, A96
RT17	SENSOR, OUTDOOR AIR
RT37	SENSOR THERMISTOR 1, COMPRESSOR 1
RT38	SENSOR THERMISTOR 2, COMPRESSOR 2
RT39	SENSOR THERMISTOR 3, COMPRESSOR 3
RT40	SENSOR THERMISTOR 4, COMPRESSOR 4
S4	SWITCH, LIMIT HI PRESS COMPRESS 1
S5	SWITCH, LIMIT HI TEMP COMPRESSOR 1
S8	SWITCH, LIMIT HI TEMP COMPRESSOR 2
S11	SWITCH, LOW PRESS, LOW AMBIENT COMP 1
S28	SWITCH, LIMIT HI PRESS COMPRESS 3
S31	LIMIT, HIGH TEMP COMPRESSOR 3
S48	SWITCH, DISCONNECT
S49	SWITCH, FREEZE STAT COMPRESS 1
S53	SWITCH, FREEZE STAT COMPRESS 3
S85	SWITCH, LOW PRESS, LOW AMBIENT KJT COMP 3
S87	SWITCH, LOW PRESS, COMP 1
S98	SWITCH, LOW PRESS, COMP 3
S117	SWITCH, GFI
S180	LIMIT, HIGH TEMP COMPRESSOR 4
T1	TRANSFORMER, CONTROL
T5	TRANSFORMER, OUTDOOR FAN MOTOR
T18	TRANSFORMER, CONTACTOR
T29	TRANSFORMER, GFI
T59	TRANSFORMER, OUTDOOR FAN MOTOR
TB13	TERMINAL STRIP, POWER DISTRIBUTION

## Sequence of Operation LCH180U/240U/300U

### POWER:

1. Line voltage from TB2, unit disconnect S48, or other factory or field installed optional power disconnects, such as CB10, energizes transformer T1 and T18. Transformer T1 provides 24VAC power to the A55 Unit Controller and T18 provides 24VAC power to A59 Compressor 3 and 4 Controller. The two controllers provide 24VAC power to the unit cooling, heating and blower controls and thermostat.
2. Terminal block TB13 is also energized when the unit disconnect closes. TB13 supplies line voltage to compressor crankcase heaters, compressors, blower motors and fan motors.

### BLOWER OPERATION (OCP INPUT MUST BE ON):

3. See Staged No Bypass and Staged With Bypass next 2 pages.

### ECONOMIZER OPERATION:

4. The A55 Unit Controller receives a demand and energizes exhaust fan relay K65 and K231 with 24VAC at 50% (travel) outside air damper open (adjustable).
5. N.O. K65-1, K65-2, K231-01 and K231-02 close, energizing exhaust fan motors B10 and B11.

### 1ST STAGE COOLING

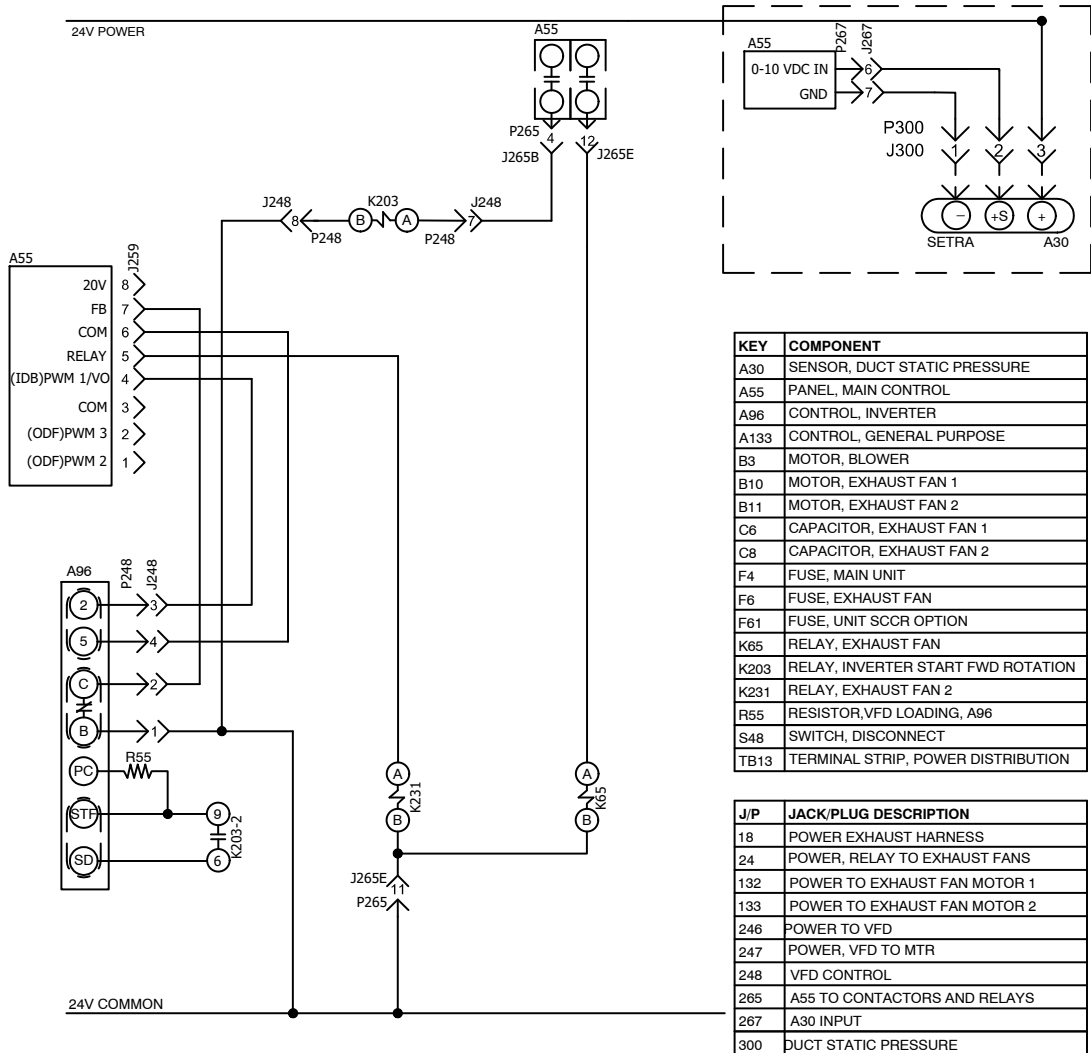
6. First stage cooling demand energizes Y1 and G in the thermostat. G energizes blower, if blower is not already running (see step 3).

7. 24VAC is routed to the A55 Unit Controller. After A55 proves N.C. low pressure switch S87, N.C. freezestat S49, and N.C. high pressure switch S4, high temperature limits S5 and S8, compressor contactors K1 and K2 are energized.
8. N.O. contacts K1-1 and K2-1 close energizing compressor B1 and B2.
9. A55 Unit Controller and A178 Compressor 3 and 4 Controller energize fan transformers T5 and T59 based on low ambient switch S11 and S85 inputs and predefined control logic.
10. Transformer T5 energizes outdoor fans B4, B5 and B21. Transformer T59 energizes outdoor fan B22, B23 and B24.
11. Relay contacts K191-2, K194-2 open de-energizing compressor 1 and 2 crankcase heater HR1 and HR2.

### 2ND STAGE COOLING

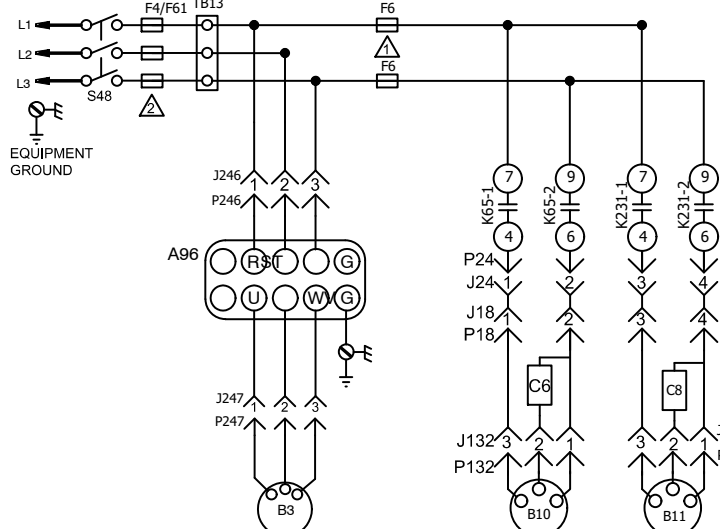
12. Second stage cooling demand energizes Y2.
13. 24VAC is routed to A178 Compressor 3 and 4 Controller. After A178 proves N.C. low pressure switch S98, N.C. freezestat S53, and N.C. high pressure switch S28, high temperature limits S31 and S180, compressor contactors K14 and K146 are energized
14. N.O. contacts K14-1 close energizing compressor B13.
15. N.O. contacts K146-1 close energizing compressor B20.
16. N.C. contacts K233-2 and K234-01 open de-energizing compressor 3 and 4 crankcase heater HR5 and HR11.

# Staged-Blower UNITS - NO BYPASS



KEY	COMPONENT
A30	SENSOR, DUCT STATIC PRESSURE
A55	PANEL, MAIN CONTROL
A96	CONTROL, INVERTER
A133	CONTROL, GENERAL PURPOSE
B3	MOTOR, BLOWER
B10	MOTOR, EXHAUST FAN 1
B11	MOTOR, EXHAUST FAN 2
C6	CAPACITOR, EXHAUST FAN 1
C8	CAPACITOR, EXHAUST FAN 2
F4	FUSE, MAIN UNIT
F6	FUSE, EXHAUST FAN
F61	FUSE, UNIT SCCR OPTION
K65	RELAY, EXHAUST FAN
K203	RELAY, INVERTER START FWD ROTATION
K231	RELAY, EXHAUST FAN 2
R55	RESISTOR, VFD LOADING, A96
S48	SWITCH, DISCONNECT
TB13	TERMINAL STRIP, POWER DISTRIBUTION

J/P	JACK/PLUG DESCRIPTION
18	POWER EXHAUST HARNESS
24	POWER, RELAY TO EXHAUST FANS
132	POWER TO EXHAUST FAN MOTOR 1
133	POWER TO EXHAUST FAN MOTOR 2
246	POWER TO VFD
247	POWER, VFD TO MTR
248	VFD CONTROL
265	A55 TO CONTACTORS AND RELAYS
267	A30 INPUT
300	DUCT STATIC PRESSURE



⚠ F6 FUSES ARE USED ON 240/300 Y - VOLT UNITS WITH FACTORY INSTALLED POWER EXHAUST

F6 FUSES ARE USED ON ALL Y - VOLT UNITS WITH FIELD INSTALLED POWER EXHAUST

⚠ F4 USED ON LCH UNITS.

F61 USED ON LGH UNITS WITH SCCR OPTION

--- DENOTES OPTIONAL COMPONENTS

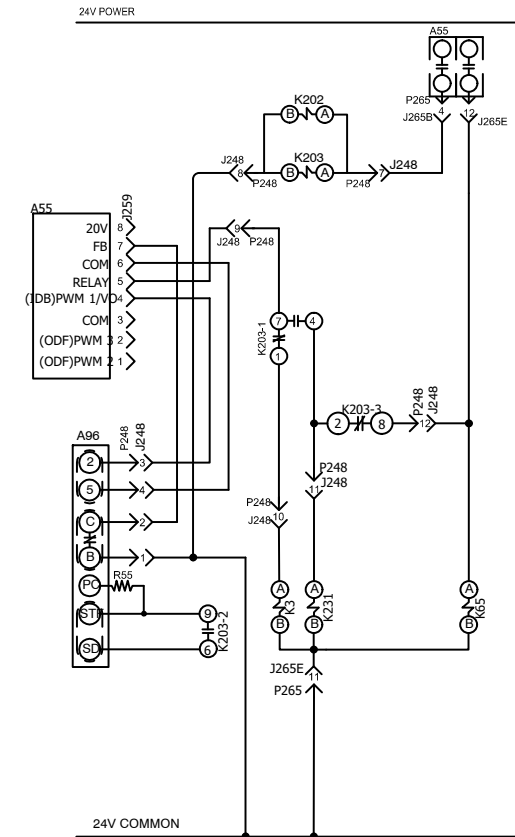
---> DENOTES FIELD INSTALLED WIRING

2019/02	WIRING DIAGRAM	02/19
	537718-03	
COOLING		
MSAV/ VAV BLOWER - NO BYPASS		
SECTION B3		REV. 1
Supersedes 537718-02	New Form No. 537718-03	

### OPERATION:

- A55 energizes the K203 relay coil.
- K203-2 N.O. contacts close to start A96 forward rotation signal STF.
- A133 controls the second stage power exhaust relay K231 coil through pin #5. K231-1 and -2 N.O. contacts will close to start the second power exhaust fan when A133 energizes the K231 coil.
- Blower B3 speed is controlled by a 0-10VDC signal from A133 AO1 to A96 terminal 2.
- A96 status is monitored by A133 through N.C. contacts B-C on A96.

# MSAV UNITS - WITH BYPASS



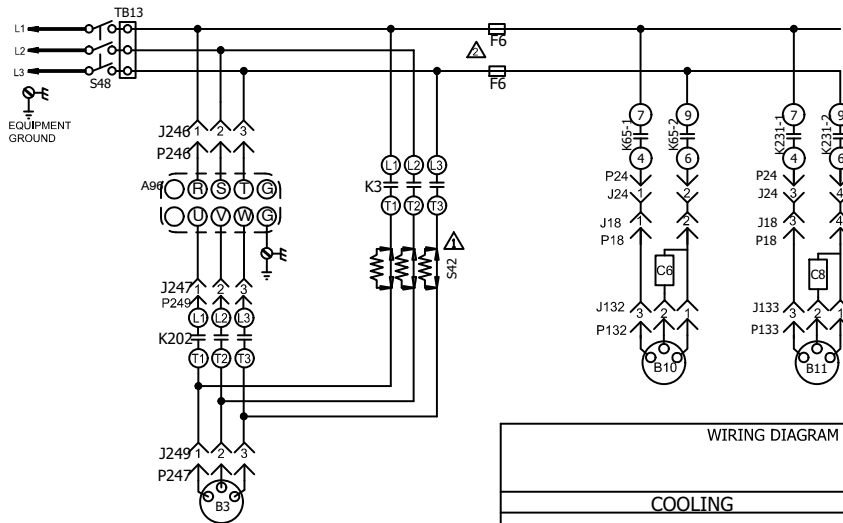
KEY	COMPONENT
A55	PANEL, MAIN CONTROL
A96	CONTROL, INVERTER
A133	CONTROL, GENERAL PURPOSE
B3	MOTOR, BLOWER
B10	MOTOR, EXHAUST FAN 1
B11	MOTOR, EXHAUST FAN 2
C6	CAPACITOR, EXHAUST FAN 1
C8	CAPACITOR, EXHAUST FAN 2
F6	FUSE, EXHAUST FAN
K3	CONTACTOR, BLOWER
K65	RELAY, EXHAUST FAN
K202	CONTACTOR, VFD POWER TO MOTOR
K203	RELAY, INVERTER START FWD ROTATION
K231	RELAY, EXHAUST FAN 2
R55	RESISTOR, VFD LOADING, A96
S42	SWITCH, OVERLOAD RELAY BLWR MOTOR
S48	SWITCH, DISCONNECT
TB13	TERMINAL STRIP, POWER DISTRIBUTION

J/P	JACK/PLUG DESCRIPTION
18	POWER EXHAUST HARNESS
24	POWER, RELAY TO EXHAUST FANS
132	POWER TO EXHAUST FAN MOTOR 1
133	POWER TO EXHAUST FAN MOTOR 2
194	GP CONTROL INPUT, OUTPUT
246	POWER TO VFD
247	POWER, VFD TO MTR
248	VFD CONTROL
249	POWER, CONTACTOR BYPASS
265	A55 TO CONTACTORS & RELAYS

⚠ S42 USED ON M-VOLT UNITS AND UNITS WITH HIGH EFFICIENCY MOTORS AND MOTORS LESS INTERNAL OVERLOAD PROTECTION

⚠ F6 FUSES ARE USED ON 240/300 Y-VOLT UNITS WITH FACTORY INSTALLED POWER EXHAUST

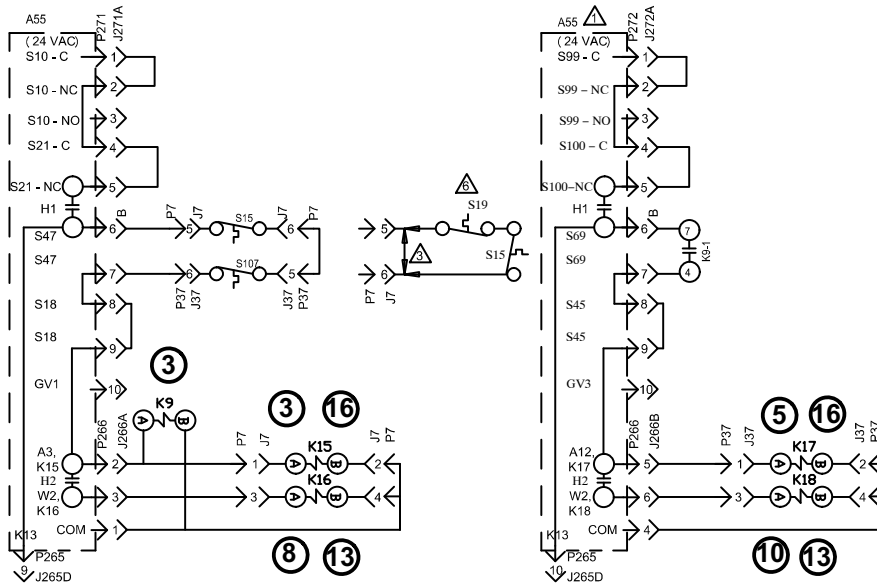
F8 FUSES ARE USED ON ALL Y-VOLT UNITS WITH FIELD INSTALLED POWER EXHAUST



WIRING DIAGRAM		03/17
<b>COOLING</b>		
MSAV BLOWER - WITH BYPASS		
SECTION B3		REV. 0
Supersedes 537391-01	New Form No. 537719-02	

- 1 A55 energizes K202 and K203 relay coils.
- 2 K203-1 N.O. contacts close and K203-3 N.C. contacts open to allow A133 to control the second stage power exhaust relay K231 coil through pin #5. K231-1 and -2 N.O. contacts will close to start the second power exhaust fan B11 when A133 energizes K231 coil.
- 3 K203-1 N.C. contacts open to de-energize K3 relay coil. K3 contacts open to interrupt power to B3 blower motor through K3 N.O. relay contacts.
- 4 K202 contacts close to allow power to B3 blower motor from A96.
- 5 K203-2 N.O. contacts close to start A96 forward rotation signal STF.
- 6 Blower B3 speed is controlled by a 0-10VDC signal from A133 AO1 to A96 terminal 2.
- 7 A96 status is monitored by A133 through N.C. contacts B-C on A96.

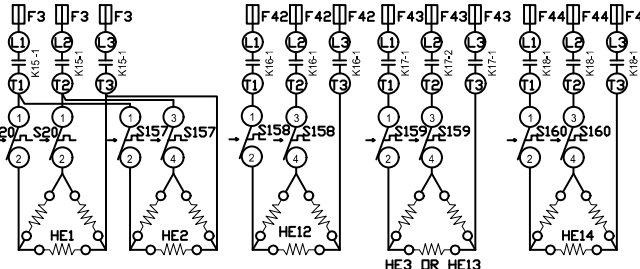
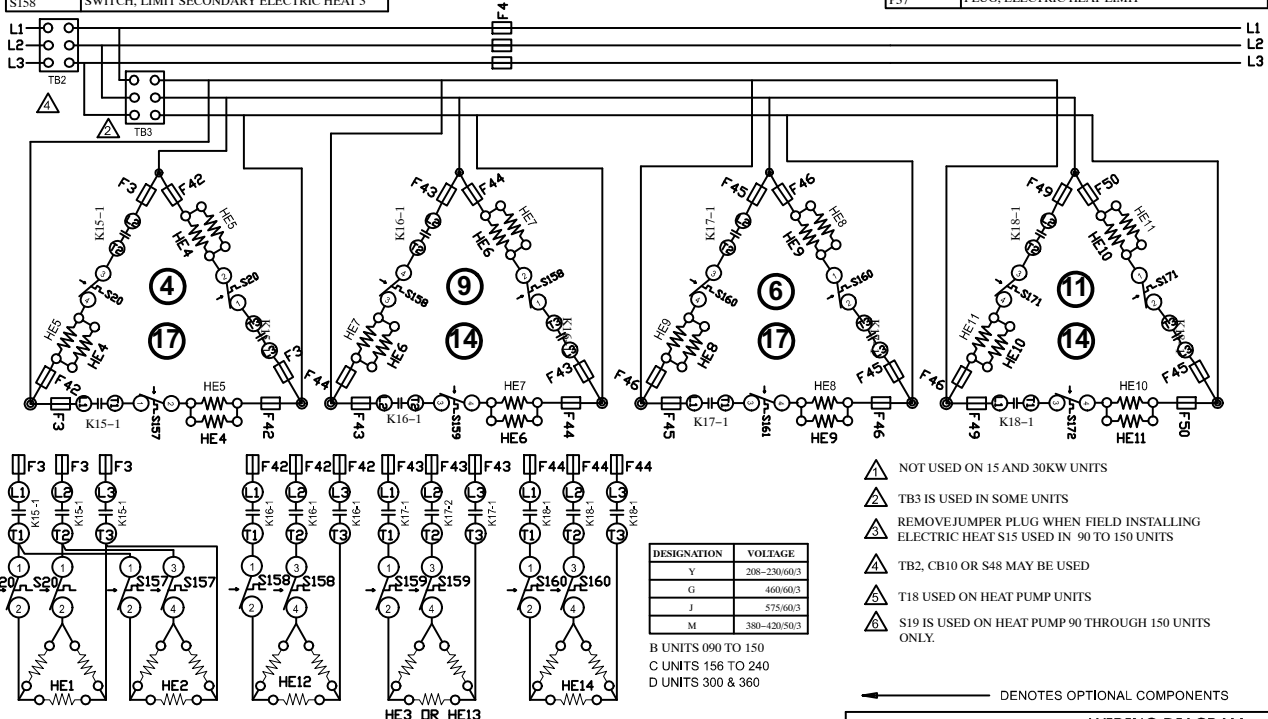
# ELECTRIC HEAT DIAGRAM



P271	PLUG, HEATING SENSORS 1
P272	PLUG, HEATING SENSORS 2
P265	PLUG, CONTACTOR RELAY
P266	PLUG, HEATING CONTROL
S15	SWITCH, LIMIT PRIMARY ELECTRIC HEAT
S19	THERMOSTAT, ELECTRIC HEAT LIMIT
S20	SWITCH, LIMIT SECONDARY ELECTRIC HEAT 1
S107	SWITCH, PRIMARY ELECTRIC HEAT
S157	SWITCH, LIMIT SECONDARY ELECTRIC HEAT 2
S158	SWITCH, LIMIT SECONDARY ELECTRIC HEAT 3

S159	SWITCH, LIMIT SECONDARY ELECTRIC HEAT 4
S160	SWITCH, LIMIT SECONDARY ELECTRIC HEAT 5
S161	SWITCH, LIMIT SECONDARY ELECTRIC HEAT 6
S171	SWITCH, LIMIT SECONDARY ELECTRIC HEAT 7
S172	SWITCH, LIMIT SECONDARY ELECTRIC HEAT 8
TB2	TERMINAL STRIP, UNIT
TB3	TERMINAL STRIP, ELECTRIC HEAT

DESCRIPTION	
KEY	DESCRIPTION
A55	PANEL, MAIN
F3	FUSE, ELECTRIC HEAT 1
F4	FUSE, UNIT
F42	FUSE, ELECTRIC HEAT 2
F43	FUSE, ELECTRIC HEAT 3
F44	FUSE, ELECTRIC HEAT 4
F45	FUSE, ELECTRIC HEAT 5
F46	FUSE, ELECTRIC HEAT 6
F49	FUSE, ELECTRIC HEAT 7
F50	FUSE, ELECTRIC HEAT 8
HE1	ELEMENT, ELECTRIC HEAT 1
HE2	ELEMENT, ELECTRIC HEAT 2
HE3	ELEMENT, ELECTRIC HEAT 3
HE4	ELEMENT, ELECTRIC HEAT 4
HE5	ELEMENT, ELECTRIC HEAT 5
HE6	ELEMENT, ELECTRIC HEAT 6
HE7	ELEMENT, ELECTRIC HEAT 7
HE8	ELEMENT, ELECTRIC HEAT 8
HE9	ELEMENT, ELECTRIC HEAT 9
HE10	ELEMENT, ELECTRIC HEAT 10
HE11	ELEMENT, ELECTRIC HEAT 11
HE12	ELEMENT, ELECTRIC HEAT 12
HE13	ELEMENT, ELECTRIC HEAT 13
HE14	ELEMENT, ELECTRIC HEAT 14
J7	JACK, ELECTRIC HEAT SUB-BASE KIT
J37	JACK, ELECTRIC HEAT LIMIT
J271	JACK, HEATING SENSORS 1
J272	JACK, HEATING SENSORS 2
J265C	JACK, CONTACTOR RELAY
J266	JACK, HEATING CONTROL
K9-1	RELAY, HEATING
K15-1	CONTACTOR, ELECTRIC HEAT 1,2
K16-1	CONTACTOR, ELECTRIC HEAT 1A,2A
K17-1	CONTACTOR, ELECTRIC HEAT 3,4
K18-1	CONTACTOR, ELECTRIC HEAT 5,6
P7	PLUG, ELECTRIC HEAT SUB-BASE KIT
P37	PLUG, ELECTRIC HEAT LIMIT



DESIGNATION	VOLTAGE
Y	208-230/60/3
G	460/60/3
J	575/60/3
M	380-420/50/3

B UNITS 090 TO 150  
 C UNITS 156 TO 240  
 D UNITS 300 & 360

- ⚠ NOT USED ON 15 AND 30KW UNITS
- ⚠ TB3 IS USED IN SOME UNITS
- ⚠ REMOVE JUMPER PLUG WHEN FIELD INSTALLING ELECTRIC HEAT S15 USED IN 90 TO 150 UNITS
- ⚠ TB2, CB10 OR S48 MAY BE USED
- ⚠ T18 USED ON HEAT PUMP UNITS
- ⚠ S19 IS USED ON HEAT PUMP 90 THROUGH 150 UNITS ONLY.

B	KW	HE1	HE2	HE3	HE4	HE5	HE6	HE7	HE8	HE9	HE10	HE11
45	15					15	15	15				
60				15	15	15	15					
15	7.5	7.5										
30			15	15								
90	15		15			15	15				15	15

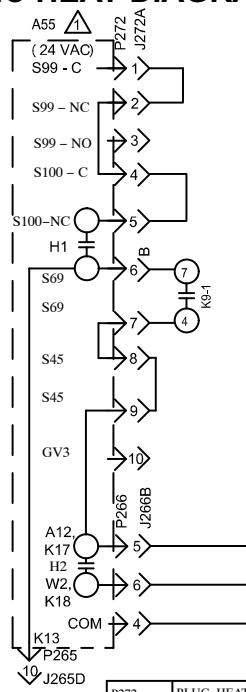
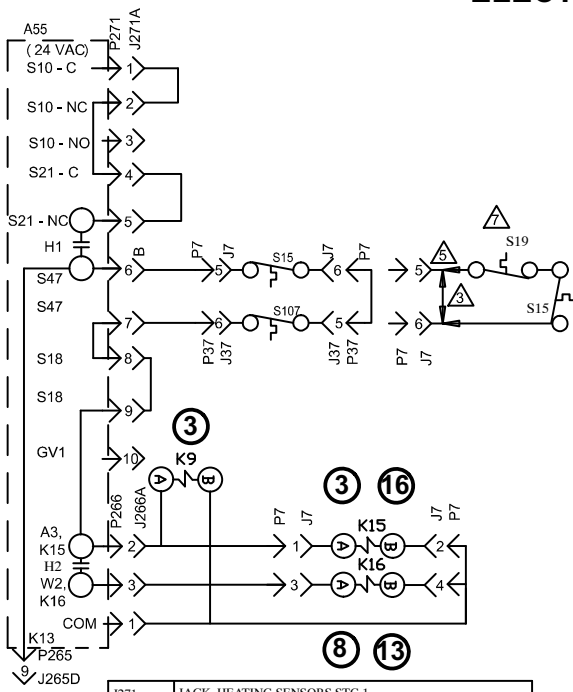
C-D	KW	HE1	HE12	HE13	HE14
45	15		7.5	15	7.5
60	15		15	15	15

WIRING DIAGRAM	10/09
<b>HEATING</b>	
ELECTRIC HEAT FOR ENERGENGE™ E1EH, EHA - 15,30,45,60,90,120 - Y	
SECTION A	
Supersedes	New Form No. 537188-01

# ELECTRIC HEAT DIAGRAM

DESCRIPTION	
KEY	DESCRIPTION
A55	CONTROL, BOARD LENNOX
F3	FUSE, ELECTRIC HEAT
F4	FUSE, UNIT
F42	FUSE, ELECTRIC HEAT 1 A, 2A
F43	FUSE, ELECTRIC HEAT 3, 4
F44	FUSE, ELECTRIC HEAT 5
F45	FUSE, ELECTRIC HEAT 6, 7
HE1	ELEMENT, ELECTRIC HEAT 1
HE2	ELEMENT, ELECTRIC HEAT 2
HE3	ELEMENT, ELECTRIC HEAT 3
HE4	ELEMENT, ELECTRIC HEAT 4
HE5	ELEMENT, ELECTRIC HEAT 5
HE6	ELEMENT, ELECTRIC HEAT 6
HE7	ELEMENT, ELECTRIC HEAT 7
HE8	ELEMENT, ELECTRIC HEAT 8
J7	JACK, ELECTRIC HEAT SUB-BASE KIT
J37	JACK, ELECTRIC HEAT LIMIT
J265	JACK, CONTACTOR RELAY
J266	JACK, HEATING CONTROL

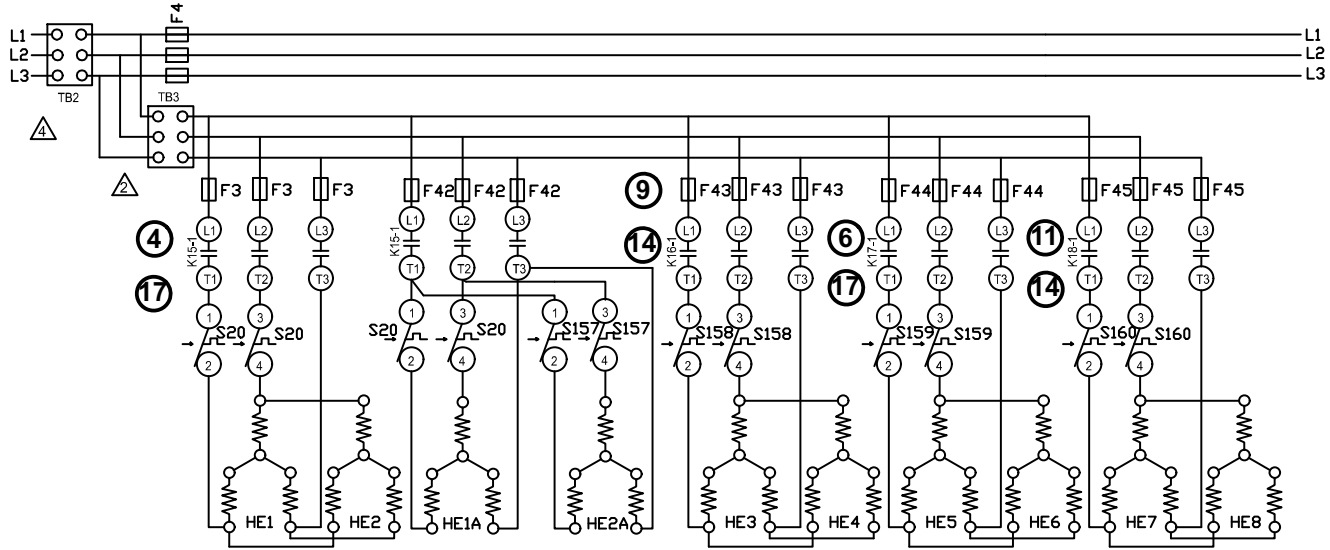
DESIGNATION	VOLTAGE
G	460/60.3
J	575/60.3



J271	JACK, HEATING SENSORS STG 1
J272	JACK, HEATING SENSORS STG 2
K9,-1	RELAY, HEAT
K15,-1	CONTACTOR, ELECTRIC HEAT 1,2
K16,-1	CONTACTOR, ELECTRIC HEAT 1A,2A
K17,-1	CONTACTOR, ELECTRIC HEAT 3,4
K18,-1	CONTACTOR, ELECTRIC HEAT 5,6
P7	PLUG, ELECTRIC HEAT SUB-BASE KIT
P37	PLUG, ELECTRIC HEAT LIMIT
P265	PLUG, CONTACTOR RELAY
P266	PLUG, HEATING CONTROL
P271	PLUG, HEATING SENSORS STG 1

P272	PLUG, HEATING SENSORS STG 2
S15	SWITCH, LIMIT PRIMARY ELECTRIC HEAT
S19	THERMOSTAT, ELECTRIC HEAT LIMIT
S20	SWITCH, LIMIT SECONDARY ELECTRIC HEAT 1,2
S107	SWITCH, PRIMARY ELECTRIC HEAT
S157	SWITCH, LIMIT SECONDARY ELECTRIC HEAT 1A
S158	SWITCH, LIMIT SECONDARY ELECTRIC HEAT 2A
S159	SWITCH, LIMIT SECONDARY ELECTRIC HEAT 3,4
S160	SWITCH, LIMIT SECONDARY ELECTRIC HEAT 5,6
TB2	TERMINAL STRIP, UNIT
TB3	TERMINAL STRIP, ELECTRIC HEAT

B UNITS 090 TO 150  
C UNITS 156 TO 240  
D UNITS 300 & 360



- ⚠ NOT USED ON 15 AND 30KW UNITS
- ⚠ TB2, S48 OR CB10 MAY BE USED
- ⚠ TB3 IS USED IN SOME UNITS
- ⚠ S15 IS USED ON B UNITS 90 TO 150
- ⚠ REMOVE JUMPER PLUG WHEN FIELD INSTALLING ELECTRIC HEAT
- ⚠ T18 USED ON HEAT PUMP UNITS
- ⚠ S19 IS USED ON HEAT PUMP 090 THROUGH 150 UNITS ONLY.

← DENOTES OPTIONAL COMPONENTS

B	CW	HE1	HE2	H1A	H2A	HE3	HE4	HE5	HE6	HE7	HE8
	45	15				15	15				
	60	15	15			15	15				
C	15			7.5	7.5						
	30			15	15						
	45	15				15		15		7.5	
	60	15				15		15		15	
	90	15				15	15	15		15	15
D	120	15	15			15	15	15	15	15	15

WIRING DIAGRAM
04/10

---

**HEATING**

**ELECTRIC HEAT FOR ENERGENCE™**  
E1EH, EHA - 15,30,45,60,90,120 - G,J

**SECTION A**

Supersedes	New Form No.
	537187-02



**SEQUENCE OF OPERATION**  
**EHA-15, 30, 45, 60, 90 - Y**  
**EHA-15, 30, 45, 60, 90 - G, J and M**

The Y voltage diagram use elements configured in a Wye. The G and J voltage diagram use elements configured in a Delta. Both diagrams follow the following sequence of operation:

*NOTE: Two electric heat sections are used in all 15kW through 90kW heaters. The heat sections are labelled first electric heat section (left side) and second electric heat section (right side). See figure 16.*

*NOTE: In the case of EHA 15 and 30kW, the second heat section (right side) is a slave (only has electric heat elements and a limit). Line voltage is supplied to elements in both heat section one (left side) and two (right side) by the contactors in heat section one (left side).*

**HEATING ELEMENTS:**

- 1 Terminal strip TB3 is energized when the unit disconnect closes. TB3 supplies line voltage to electric heat elements HE1 through HE14. Each heating element is protected by fuse F3.

**FIRST STAGE HEAT:**

- 2 Heating demand initiates at W1 in thermostat.
- 3 24VAC is routed to the main control module A55. After A55 proves N.C. primary limits S15 (heat section one, left side), S107 (heat section two, right side), the electric heat contactor K15 and heat relay K9 are energized.
- 4 N.O. contact K15-1 closes allowing the first bank of elements in heat section one (left side) to be energized.
- 5 At the same time, N.O. contacts K9-1 close. A N.O. contact in A55 closes, energizing electric heat relay K17.

- 6 N.O. contacts K17-1 close allowing the first set of elements in heat section two (right side) to be energized.

**SECOND STAGE HEAT:**

- 7 With the first stage heat operating, an additional heating demand initiates at W2 in the thermostat.
- 8 24VAC is routed through the main control module A55, which in turn energizes the electric heat contactor K16.
- 9 N.O. contacts K16-1 close allowing the second set of elements in heat section one (left side) to be energized.
- 10 Simultaneous with step eight, a N.O. contact in the A55 Unit controller closes, allowing 24VAC to energize electric heat contactor K18.
- 11 N.O. contacts K18-1 close allowing the second set of elements in heat section two (right side) to be energized.

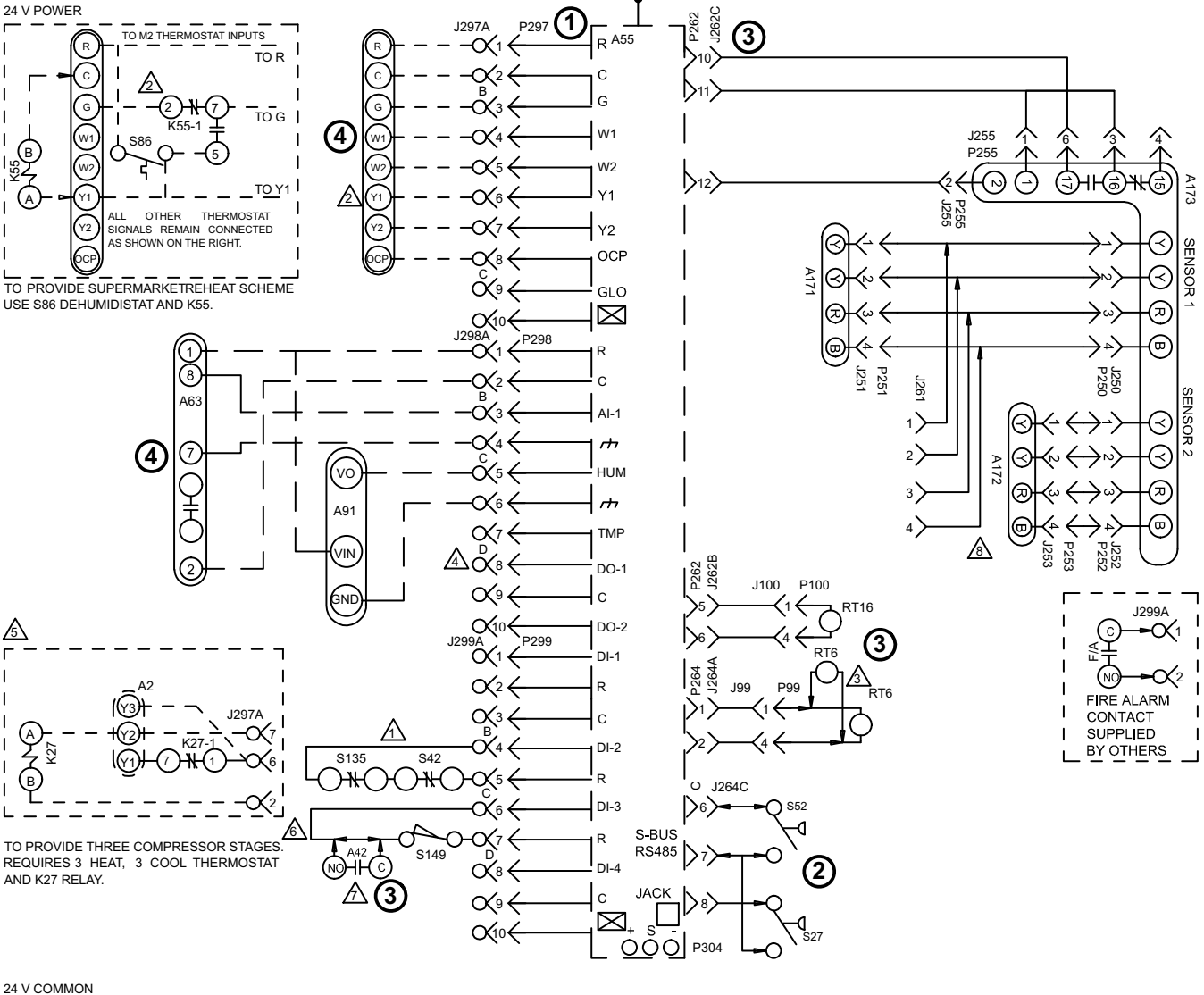
**END OF SECOND STAGE HEAT:**

- 12 Heating demand is satisfied. Terminal W2 in the thermostat is de-energized.
- 13 Electric heat contactors K16 and K18 are de-energized.
- 14 The second set of electric heat elements in heat sections one (left side) and two (right side) are de-energized.

**END OF FIRST STAGE HEAT:**

- 15 Heating demand is satisfied. Terminal W1 in the thermostat is de-energized.
- 16 Electric heat contactors K15 and K17 are de-energized.
- 17 The first set of electric heat elements in heat sections one (left side) and two (right side) are de-energized.

# ELECTRONIC OR ELECTROMECHANICAL THERMOSTAT



- ⚠ FOR MOTORS WITH S42 AND S135 EXTERNAL OVERLOAD LESS INVERTER, SEE INVERTER WITH BY PASS FOR S42 HOOK UP
  - ⚠ A42 USED ON 036 THROUGH 72 UNITS ONLY
  - 2 USE S86 DEHUMIDISTAT AND K55 FOR OPTIONAL SUPERMARKET REHEAT SCHEME, M2 PARAMETERS NEED TO BE MODIFIED UNDER THE SETTINGS MENU OR VIA UC SOFTWARE FOR SIMULTANEOUS HEATING AND COOLING.
  - ⚠ CONNECT A172 SENSOR TO J261 ON SUPPLY AIR SMOKE DETECTOR ONLY
  - 3 REMOTE LOCATION OF RT6
  - ⚠ P298-8 (DO-1) IS SERVICE RELAY OUTPUT (24VAC) IF USED CONNECT TO AN INDICATOR LIGHT
  - ⚠ THERMOSTAT HOOKUP FOR PROGRAMMABLE CONFIGURATION OF THE M2 BOARD (A55).
  - ⚠ M2 SETTINGS MUST BE MODIFIED WHEN A42, S42, S52, S135 OR S149 ARE INSTALLED
- DESIGNATES OPTIONAL WIRING  
 - - - - - CLASS II FIELD WIRING

	WIRING DIAGRAM	11/09
	ACCESSORIES	
ELECTRONIC OR ELECTROMECHANICAL THERMOSTAT FOR EMERGENCE™		
SECTION C		REV. 3.0
Supersedes	New Form No. 537108-01	
© 2009 Lennox Commercial		

**POWER:**

1 Terminal block P297 on the A55 Unit Controller energizes the thermostat components with 24VAC.

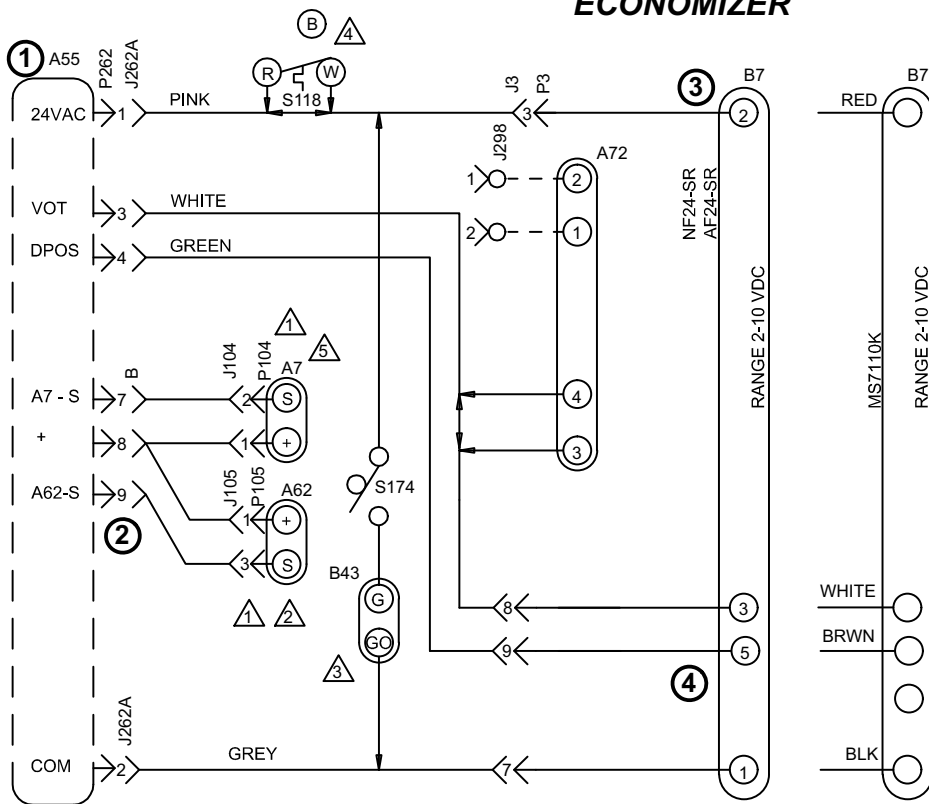
**OPERATION:**

- 2 The A55 Unit Controller proves the optional N.O. filter switch S27 (indicates dirty filter when closed) and optional N.O. air flow switch S52 (indicates no air [i.e. broken belt] system shuts down).
- 3 The A55 receives data from the supply and return smoke detectors A171 and A172, blower motor overload relay S42, discharge sensor RT6 and return air sensor RT16.
- 4 The A55 receives data from the electronic thermostat A2 (Y1, Y2, W1, W2, G, OCP) and the CO<sub>2</sub> sensor (if economizer is used) via terminal block P297. A55 energizes the appropriate components.

## ELECTRONIC OR ELECTROMECHANICAL THERMOSTAT KEY DESCRIPTION

DESCRIPTION	
KEY	COMPONENT
A2	SENSOR, ELECTRONIC THERMOSTAT
A42	MONITOR, PHASE PROTECTOR
A55	PANEL, MAIN
A63	SENSOR, CO2 (IAQ) OPTIONAL
A91	SENSOR, HUMIDITY
A171	SENSOR ONE, SMOKE, RETURN AIR
A172	SENSOR TWO, SMOKE, SUPPLY AIR
A173	MODULE, CONTROL SMOKE DETECTION
J99	JACK, RT16 RETURN AIR SENSOR
J100	JACK, RT6 SUPPLY AIR SENSOR
J250	JACK, SMOKE DETECTOR ONE
J251	JACK, SMOKE DETECTOR ONE
J252	JACK, SMOKE DETECTOR TWO
J253	JACK, SMOKE DETECTOR TWO
J255	JACK, MODULE, CONTROL SMOKE DETECTION
J261	JACK, SUPPLY SMOKE DETECTOR JUMPER
J262	JACK, ECONOMIZER
J264	JACK, BLOWER DECK
J297	JACK, THERMOSTAT - DDC INTERFACE
J298	JACK, IAQ INTERFACE
J299	JACK, SAFETY INTERFACE
K27, -1	RELAY, TRANSFER
K55,-1	RELAY, BLOWER
P99	PLUG, RT16 RETURN AIR SENSOR
P100	PLUG, RT6 SUPPLY AIR SENSOR
P250	PLUG, SMOKE DETECTOR ONE
P251	PLUG, SMOKE DETECTOR ONE
P252	PLUG, SMOKE DETECTOR TWO
P253	PLUG, SMOKE DETECTOR TWO
P255	PLUG, MODULE, CONTROL SMOKE DETECTION
P262	PLUG, ECONOMIZER
P264	PLUG, BLOWER DECK
P297	PLUG, THERMOSTAT - DDC INTERFACE
P298	PLUG, IAQ INTERFACE
P299	PLUG, SAFETY INTERFACE
P304	PLUG, SYS BUS
RT6	SENSOR, SUPPLY AIR TEMP
RT16	SENSOR, RETURN AIR TEMP
S27	SWITCH, FILTER
S52	SWITCH, AIRFLOW
S42	SWITCH, OVERLOAD RELAY BLOWER MOTOR LO
S86	SWITCH, DEHUMIDISTAT
S135	SWITCH, OVERLOAD RELAY BLOWER MOTOR HI
S149	SWITCH, OVERFLOW

# ECONOMIZER

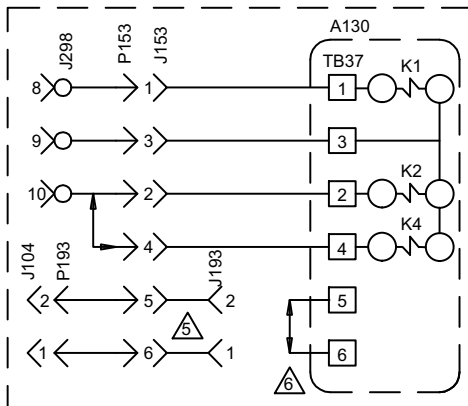


- ⚠️ DELETE A7 AND A62 (IF USED) FOR EITHER GLOBAL ENTHALPY OR SENSIBLE TEMPERATURE CONTROL
- ⚠️ FOR UNIT DIFFERENTIAL ENTHALPY CONTROL, ADD A62 RETURN AIR ENTHALPY SENSOR
- ⚠️ OPTIONAL EXHAUST DAMPER ACTUATOR TO HOLD EXHAUST DAMPER CLOSED WHEN OUTSIDE AIR DAMPER IS CLOSED
- ⚠️ S118 USED ON 35 TO 50 TON ENERGENCE UNITS WITH ENERGY RECOVERY WHEEL (ERW)

- ⚠️ REPOSITION A7 ENTHALPY SENSOR FROM ROOFTOP UNIT ECONOMIZER INTO INTAKE HOOD OF THE ERW ROOFTOP UNIT
- ⚠️ REMOVE JUMPER WHEN INSTALLING OPTIONAL LOW AMBIENT SWITCH

NOTE- THIS DIAGRAM USED ONLY WHEN ECONOMIZER OR MOTORIZED OUTDOOR AIR DAMPERS ARE INSTALLED.

KEY	DESCRIPTION
A7	SENSOR, SOLID STATE ENTHALPY
A130	CONTROL, ERS
A55	CONTROL, MAIN PANEL LENNOX
A62	SENSOR, ENTHALPY INDOOR
A72	CONTROL, REMOTE MIN POS (OPT)
B7	MOTOR, DAMPER ECONOMIZER
B43	MOTOR, EXHAUST DAMPER
J3	JACK, UNIT ECONOMIZER
J104	JACK, SENSOR OUTDOOR ENTHALPY
J105	JACK, SENSOR RETURN AIR ENTHALPY
J153	JACK, ENTHALPY / DAMPER MOTOR
J193	JACK, ENTHALPY SENSOR
J298A	JACK, IAQ INTERFACE
J262A	JACK, DAMPER MOTOR
J262B	JACK, ENTHALPY SENSORS
P3	PLUG, ECONOMIZER BYPASS
P153	PLUG, ENTHALPY / DAMPER MOTOR
P193	PLUG, ENTHALPY SENSOR
P262	PLUG, ECONOMIZER OUTPUT
S118	THERMOSTAT, DESICANT DEFROST
S174	SWITCH, EXHAUST DAMPER



ENERGY RECOVERY WHEEL HOOK UP

— — — — — DESIGNATES OPTIONAL WIRING  
 - - - - - CLASS II FIELD WIRING

WIRING DIAGRAM		09/09
ACCESSORIES		
ENERGENCE™ SERIES ECONOMIZER AND MOTORIZED OAD PIVOTING WHEEL ENERGY RECOVERY SYSTEM OPTION		
SECTION D		
Supersedes	New Form No.	
	537189-01	

© 2009

Lennox Commercial

## ECONOMIZER SEQUENCE OF OPERATION

### POWER:

1 A55 Unit Controller energizes the economizer components with 24VAC.

### OPERATION:

- 2 The A55 along with outdoor enthalpy sensor A7 and indoor enthalpy sensor A62 (if differential enthalpy is used) determine when to power the damper motor B7.
- 3 A55 supplies B7 with 0 - 10 VDC to control the positioning of economizer.
- 4 The damper actuator provides 2 to 10 VDC position feedback.