

UNIT INFORMATION

Corp. 1112-L2
Revised 05/2020

LGH/LCH
20 / 25 / 30 TON
71 / 88 / 105 kW

LGH/LCH SERIES

The LGH/LCH242H, 300H, 360H (20, 25 and 30 ton) units are configured to order units (CTO) with a wide selection of factory-installed options. The LGH gas/electric packaged rooftop units are available in 260,000 Btuh, 360,000 Btuh and 480,000 Btuh (76.2 kW, 105.5 and 137.7 kW) heating inputs. Gas heat sections are designed with aluminized steel tube heat exchangers. The LCH cooling packaged rooftop units are equipped with the same cooling sections as the LGH units. Units utilize four compressors.

Units may contain a supply air blower equipped with a variable frequency drive A96 (VFD) which varies supply air CFM.

Optional electric heat is factory-or field-installed in LCH units. Electric heat operates in single or multiple stages depending on the kW input size. 30kW through 120kW heat sections are available.

Units are also designed for R-410A refrigerant. See unit nameplate for refrigerant type and charge. Service equipment for R-410A units must be rated for R-410A refrigerant.

Units are designed to accept any of several different energy management thermostat control systems with minimum field wiring. Factory or field provided control options connect to the Unit Controller through Smartwire™ connectors. When "plugged in" the controls become an integral part of the unit wiring.

Information contained in this manual is intended for use by qualified service technicians only. All specifications are subject to change. Procedures outlined in this manual are presented as a recommendation only and do not supersede or replace local or state codes.

If the unit must be lifted for service, rig unit by attaching four cables to the holes located in the unit base rail (two holes at each corner). Refer to the installation instructions for the proper rigging technique.

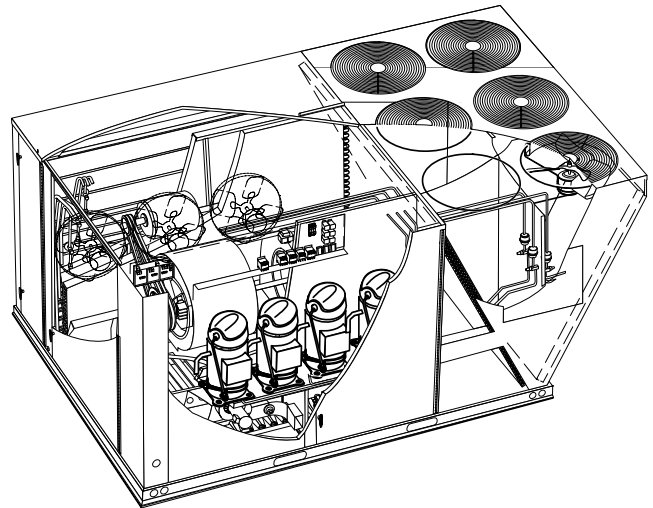

LGH360

⚠ WARNING

Improper installation, adjustment, alteration, service or maintenance can cause property damage, personal injury or loss of life. Installation and service must be performed by a qualified installer or service agency.

⚠ WARNING



Electric shock hazard. Can cause injury or death. Before attempting to perform any service or maintenance, turn the electrical power to unit OFF at disconnect switch(es). Unit may have multiple power supplies.

⚠ CAUTION

Danger of sharp metallic edges. Can cause injury. Take care when servicing unit to avoid accidental contact with sharp edges.

TABLE OF CONTENTS

| | | | |
|--|---------|--|---------|
| Introduction | Page 1 | V-MAINTENANCE | Page 66 |
| Options / Accessories | Page 3 | Filters | Page 66 |
| Specifications | Page 7 | Lubrication | Page 66 |
| High Altitude | Page 9 | Supply Air Blower Wheel | Page 66 |
| Blower Data | Page 10 | Evaporator Coil | Page 66 |
| Electrical Data / Electric Heat Data | Page 14 | Condenser Coil | Page 66 |
| Parts Arrangement | Page 25 | Electrical | Page 66 |
| | | | |
| I- UNIT COMPONENTS | Page 27 | VI-ACCESSORIES | Page 66 |
| Control Box Components | Page 26 | Roof Mounting Frames | Page 66 |
| Cooling Components | Page 31 | Control Systems | Page 67 |
| Blower Compartment | Page 34 | Transitions | Page 67 |
| Gas Heat Components | Page 38 | Supply and Return Diffusers | Page 67 |
| Electric Heat Components | Page 44 | Outdoor Air Dampers | Page 68 |
| | | Economizers | Page 68 |
| II- PLACEMENT AND INSTALLATION | Page 48 | Gravity Exhaust Dampers | Page 69 |
| | | LP / Propane Kit | Page 69 |
| III- START UP | Page 48 | Power Exhaust Fans | Page 69 |
| Preliminary Checks | Page 48 | Smoke Detectors | Page 69 |
| Cooling Start Up | Page 48 | Blower Proving Switch | Page 70 |
| Charging | Page 49 | Dirty Filter Switch | Page 70 |
| Heating Start Up | Page 62 | Optional Cold Weather Kit | Page 70 |
| Safety or Emergency Shutdown | Page 63 | Indoor Air Quality Sensor | Page 70 |
| | | Supply Air VFD | Page 70 |
| IV-SYSTEM SERVICE CHECKS | Page 63 | Drain Pan Overflow Switch | Page 71 |
| Heating System Service Checks | Page 63 | | |
| Cooling System Service Checks | Page 66 | | |
| | | VII-DIAGRAMS / OPERATION SEQUENCE . | Page 72 |

OPTIONS / ACCESSORIES

| Item Description | Model Number | Catalog Number | Unit Model No. | | |
|--|---|----------------|----------------|-----|-----|
| | | | 242 | 300 | 360 |
| COOLING SYSTEM | | | | | |
| Condensate Drain Trap | PVC - C1TRAP20AD2 | 76W26 | OX | OX | OX |
| | Copper - C1TRAP10AD2 | 76W27 | OX | OX | OX |
| Corrosion Protection | | Factory | O | O | O |
| Drain Pan Overflow Switch | E1SNSR71AD1 | 68W88 | OX | OX | OX |
| Efficiency | High | Factory | O | O | O |
| Refrigerant Type | R-410A | Factory | O | O | O |
| Plastic Condensate Drain Pan | | Factory | O | O | O |
| Stainless Steel Condensate Drain Pan | C1DPAN10D-1- | 83W42 | OX | OX | OX |
| BLOWER - SUPPLY AIR | | | | | |
| Motors | Belt Drive (standard efficiency) - 5 hp | Factory | O | O | O |
| | Belt Drive (standard efficiency) - 7.5 hp | Factory | O | O | O |
| | Belt Drive (standard efficiency) - 10 hp | Factory | O | O | O |
| | Supply VFD Blower Bypass (VAV/MSAV units w/VFD only) | Factory | O | O | O |
| Drive Kits See Blower Data Tables for usage and selection | Kit #1 740-895 rpm | Factory | O | O | O |
| | Kit #2 870-1045 rpm | Factory | O | O | O |
| | Kit #3 715-880 rpm | Factory | O | O | O |
| | Kit #4 770-965 rpm | Factory | O | O | O |
| | Kit #5 660-810 rpm | Factory | O | O | O |
| | Kit #6 770-965 rpm | Factory | O | O | O |
| | Kit #7 570-720 rpm | Factory | O | O | O |
| | Kit #8 480-630 rpm | Factory | O | O | O |
| | Kit #9 410-535 rpm | Factory | O | O | O |
| | Blower Belt Auto-Tensioner | Factory | O | O | O |
| CABINET | | | | | |
| Combination Coil/Hail Guards | C1GARD52D-1 | 13T16 | X | X | X |
| Grille Guards | C1GARD39D-1- | 86K30 | X | X | X |
| Horizontal Return Air Panel Kit | | 38K48 | X | X | X |
| CONTROLS | | | | | |
| Blower Proving Switch | C1SNSR35FF1 | 53W65 | OX | OX | OX |
| Commercial Controls | CPC Einstein Integration | Factory | O | O | O |
| | Prodigy® Control System - BACnet® Module - C0CTRL60AE1L | 59W51 | OX | OX | OX |
| | Prodigy® Control System - LonTalk® Module - C0CTRL65FF1 | 54W27 | OX | OX | OX |
| | Novar® ETM-2051 Unit Controller - E0CTRL30C1 | 64W74 | OX | OX | OX |
| | Novar® LSE | Factory | O | O | O |
| | L Connection® Building Automation System | - - - | OX | OX | OX |
| Dirty Filter Switch | E1SNSR55C-1 | 53W68 | OX | OX | OX |
| Discharge Air Temperature Sensor | | Factory | O | O | O |
| Fresh Air Tempering | C1SNSR75AD1 | 58W63 | OX | OX | OX |
| General Purpose Control Kit | E1GPBK30C1 | 13J78 | X | X | X |
| Smoke Detector - Supply or Return (Power board and one sensor) | C1SNSR44C-1 | 83W40 | OX | OX | OX |
| Smoke Detector - Supply and Return (Power board and two sensors) | C1SNSR43C-1 | 83W41 | OX | OX | OX |
| Supply Static Limit Switch | C0SNSR11AE1 | 79M80 | X | X | X |
| Supply Static Limit Switch - Mounting Kit | C0SNSR12AE1 | 79M81 | X | X | X |

NOTE - Catalog and model numbers shown are for ordering field installed accessories.

OX - Configure To Order (Factory Installed) or Field Installed

O = Configure To Order (Factory Installed)

X = Field Installed

OPTIONS / ACCESSORIES

| Item Description | Model Number | Catalog Number | Unit Model No. | | |
|---|---|----------------|----------------|-----|-----|
| | | | 242 | 300 | 360 |
| INDOOR AIR QUALITY | | | | | |
| Air Filters | | | | | |
| Healthy Climate® High Efficiency Air Filters 20 x 20 x 2 - order 12 per unit | MERV 8 - C1FLTR15D-1- | 54W21 | OX | OX | OX |
| | MERV 13 - C1FLTR40D-1- | 52W39 | OX | OX | OX |
| Replaceable Media Filter with Metal Mesh Frame (includes Non-Pleated Filter Media) 20 x 20 x 2- order 12 per unit | C1FLTR30D-1- | 44N60 | X | X | X |
| Indoor Air Quality (CO₂) Sensors | | | | | |
| Sensor - Wall-mount, off-white plastic cover with LCD display | C0SNSR50AE1L | 77N39 | X | X | X |
| Sensor - Wall-mount, off-white plastic cover, no display | C0SNSR52AE1L | 87N53 | X | X | X |
| Sensor - Black plastic case with LCD display, rated for plenum mounting | C0SNSR51AE1L | 87N52 | X | X | X |
| Sensor - Wall-mount, black plastic case, no display, rated for plenum mounting | C0MISC19AE1 | 87N54 | X | X | X |
| CO ₂ Sensor Duct Mounting Kit - for downflow applications | C0MISC19AE1- | 85L43 | X | X | X |
| Aspiration Box - for duct mounting non-plenum rated CO ₂ sensors (87N53 or 77N39) | C0MISC16AE1- | 90N43 | X | X | X |
| UVC Germicidal Light Kit | | | | | |
| ¹ Healthy Climate® UVC Light Kit (110/230v-1ph) | | Factory | O | O | O |
| ELECTRICAL | | | | | |
| Voltage 60 hz | 208/230V - 3 phase | Factory | O | O | O |
| | 460V - 3 phase | Factory | O | O | O |
| | 575V - 3 phase | Factory | O | O | O |
| HACR Circuit Breakers | | Factory | O | O | O |
| Disconnect Switch | 80 amp | 54W85 | OX | OX | OX |
| | 150 amp | 54W86 | OX | OX | OX |
| | 250 amp | 54W87 | OX | OX | OX |
| GFI Service Outlets | 15 amp non-powered, field-wired (208/230V, 460V) LTAGFIK10/15 | 74M70 | OX | OX | OX |
| | 15 amp factory-wired and powered (208/230V, 460V, 575V) | Factory | O | O | O |
| | 20 amp non-powered, field-wired (575V only) C1GFICI20FF1 | 67E01 | OX | OX | OX |
| Weatherproof Cover for GFI | C1GFICI99FF1 | 10C89 | X | X | X |
| Phase/Voltage Detection | | Factory | O | O | O |
| ELECTRIC HEAT | | | | | |
| 30 kW | 208/230V-3ph - C1EH0300C21Y | 53W92 | OX | OX | OX |
| | 460V-3ph - C1EH0300C21G | 53W94 | OX | OX | OX |
| | 575V-3ph - C1EH0300C21J | 53W95 | OX | OX | OX |
| 45 kW | 208/230V-3ph - C1EH0450C21Y | 54W00 | OX | OX | OX |
| | 460V-3ph - C1EH0450C21G | 54W02 | OX | OX | OX |
| | 575V-3ph - C1EH0450C21J | 54W03 | OX | OX | OX |
| 60 kW | 208/230V-3ph - C1EH0600C21Y | 54W08 | OX | OX | OX |
| | 460V-3ph - C1EH0600C21G | 54W10 | OX | OX | OX |
| | 575V-3ph - C1EH0600C21J | 54W11 | OX | OX | OX |
| 90 kW | 208/230V-3ph - C1EH0900C21Y | 54W12 | OX | OX | OX |
| | 460V-3ph - C1EH0900C21G | 54W14 | OX | OX | OX |
| | 575V-3ph - C1EH0900C21J | 54W15 | OX | OX | OX |
| 120 kW | 208/230V-3ph - E1EH1200D-1Y | 73W98 | OX | OX | OX |
| | 460V-3ph - E1EH1200D-1G | 73W99 | OX | OX | OX |
| | 575V-3ph - E1EH1200D-1J | 74W00 | OX | OX | OX |
| SCR (Silicon Controlled Rectifier) Electric Heat Control | | Factory | O | O | O |
| NOTE - The SCR option is not available with 60 kW, 90 kW (208/230V) and 120 kW (208/230V, 460V, 575V) electric heat models. | | | | | |
| Thermostat (required) | | 45N59 | X | X | X |
| Duct Sensor (required) | | 45N60 | X | X | X |

¹ Lamps operate on 110/230V, single phase power supply. Step-down transformer is furnished with lamps when used with 460V and 575V rooftop units.

NOTE - Catalog and model numbers shown are for ordering field installed accessories.

OX - Configure To Order (Factory Installed) or Field Installed

O = Configure To Order (Factory Installed)

X = Field Installed

OPTIONS / ACCESSORIES

| Item Description | Model Number | Catalog Number | Unit Model No. | | | |
|---|--|-------------------------|----------------|-----|-----|---|
| | | | 242 | 300 | 360 | |
| ECONOMIZER | | | | | | |
| Standard Economizer (Not for Title 24) | | | | | | |
| Standard Economizer Downflow or Horizontal Applications - Includes Outdoor Air Hood. Order Downflow or Horizontal Barometric Relief Dampers separately. | E1ECON15D-1 | 74W43 | OX | OX | OX | |
| High Performance Economizer (Approved for California Title 24 Building Standards / AMCA Class 1A Certified) | | | | | | |
| High Performance Economizer Downflow or Horizontal Applications - Includes Outdoor Air Hood. Order Downflow or Horizontal Barometric Relief Dampers separately. | E1ECON17D-1 | 10U62 | OX | OX | OX | |
| Economizer Controls | | | | | | |
| Differential Enthalpy (Not for Title 24) | Order 2 - C1SNSR64FF1 | 53W64 | OX | OX | OX | |
| Sensible Control | Sensor is Furnished | Factory | O | O | O | |
| Single Enthalpy (Not for Title 24) | C1SNSR64FF1 | 53W64 | OX | OX | OX | |
| Global, Enthalpy | Sensor Field Provided | Factory | O | O | O | |
| Building Pressure Control | E1GPBK20C1 | 13K77 | X | X | X | |
| Differential Sensible | Sensor is Furnished | Factory | O | O | O | |
| Outdoor Air CFM Control | E1GPBK10C1 | 13K76 | OX | OX | OX | |
| Barometric Relief Dampers With Exhaust Hood | | | | | | |
| Downflow Barometric Relief Dampers | E1DAMP60D-1 | 76W17 | OX | OX | OX | |
| Horizontal Barometric Relief Dampers | LAGEDH30/36 | 33K78 | OX | OX | OX | |
| OUTDOOR AIR | | | | | | |
| Outdoor Air Dampers With Outdoor Air Hood | | | | | | |
| Motorized | E1DAMP25D-1- | 74W44 | OX | OX | OX | |
| Manual | E1DAMO15D-1- | 74W45 | OX | OX | OX | |
| POWER EXHAUST | | | | | | |
| Standard Static | 208/230V - E1PWRE40D-1Y | 74W21 | OX | OX | OX | |
| | 460V - E1PWRE40D-1G | 74W22 | OX | OX | OX | |
| | 575V - E1PWRE40D-1J | 74W23 | OX | OX | OX | |
| High Static - 50% | 208/230V - Drive Kit #1 (405-533 rpm) - LAPEB30/36AY | 83M83 | X | X | X | |
| | 208/230V - Drive Kit #2 (531-731 rpm) - LAPEB30/36BY | 84M34 | X | X | X | |
| | 208/230V - Drive Kit #3 (731-932 rpm) - LAPEB30/36CY | 84M35 | X | X | X | |
| | 460V - Drive Kit #1 (405-533 rpm) - LAPEB30/36AG | 83M84 | X | X | X | |
| | 460V - Drive Kit #2 (531-731 rpm) - LAPEB30/36BG | 84M36 | X | X | X | |
| | 460V - Drive Kit #3 (731-932 rpm) - LAPEB30/36CG | 84M37 | X | X | X | |
| | 575V - Drive Kit #1 (405-533 rpm) - LAPEB30/36AJ | 83M85 | X | X | X | |
| | 575V - Drive Kit #2 (531-731 rpm) - LAPEB30/36BJ | 84M38 | X | X | X | |
| | 575V - Drive Kit #3 (731-932 rpm) - LAPEB30/36CJ | 84M39 | X | X | X | |
| High Static - 100% | 208/230V - Drive Kit #1 (406-533 rpm) - LAPEB30/36DY | 83M86 | X | X | X | |
| | 208/230V - Drive Kit #2 (531-731 rpm) - LAPEB30/36EY | 84M40 | X | X | X | |
| | 208/230V - Drive Kit #3 (731-932 rpm) - LAPEB30/36FY | 84M41 | X | X | X | |
| | 460V - Drive Kit #1 (406-533 rpm) - LAPEB30/36DG | 83M87 | X | X | X | |
| | 460V - Drive Kit #2 (531-731 rpm) - LAPEB30/36EG | 84M42 | X | X | X | |
| | 460V - Drive Kit #3 (731-932 rpm) - LAPEB30/36FG | 84M43 | X | X | X | |
| | 575V - Drive Kit #1 (406-533 rpm) - LAPEB30/36DJ | 83M88 | X | X | X | |
| | 575V - Drive Kit #2 (531-731 rpm) - LAPEB30/36EJ | 84M44 | X | X | X | |
| | 575V - Drive Kit #3 (731-932 rpm) - LAPEB30/36FJ | 84M45 | X | X | X | |
| | 100% with VFD | 208/230V - LAPEV30/36GY | 83M89 | X | X | X |
| | | 460V - LAPEV30/36GG | 83M90 | X | X | X |
| | | 575V - LAPEV30/36GJ | 83M91 | X | X | X |
| 100% with VFD and Bypass | 208/230V - LAPEV30/36HY | 83M92 | X | X | X | |
| | 460V - LAPEV30/36HG | 83M93 | X | X | X | |
| | 575V - LAPEV30/36HJ | 83M94 | X | X | X | |
| Power Exhaust Control | | | | | | |
| ¹ Pressure Switch | C0SNSR10AE1 | 79M79 | X | X | X | |

¹ Order one per unit with Standard or High Static Power Exhaust without VFD. Order two per unit with standard static power exhaust for MSAV® or VAV models.

NOTE - Catalog and model numbers shown are for ordering field installed accessories.

OX - Configure To Order (Factory Installed) or Field Installed

O = Configure To Order (Factory Installed)

X = Field Installed

OPTIONS / ACCESSORIES

| Item Description | Model Number | Catalog Number | Unit Model No. | | |
|---|-----------------|----------------|----------------|-----|-----|
| | | | 242 | 300 | 360 |
| ROOF CURBS | | | | | |
| Hybrid Roof Curbs, Downflow | | | | | |
| 14 in. height | C1CURB71D-1 | 11F62 | X | X | X |
| 18 in. height | C1CURB72D-1 | 11F63 | X | X | X |
| 24 in. height | C1CURB73D-1 | 11F64 | X | X | X |
| Standard Roof Curbs, Horizontal - Requires Horizontal Return Air Panel Kit | | | | | |
| 30 in. height - slab applications | C1CURB15C-1 | 11T90 | X | X | X |
| 41 in. height - rooftop applications | C1CURB17C-1 | 11T97 | X | X | X |
| Horizontal Return Air Panel Kit (Required) | | 38K48 | X | X | X |
| Insulation Kit For Standard Horizontal Curbs | | | | | |
| | for C1CURB15C-1 | 73K33 | X | X | X |
| | for C1CURB17C-1 | 73K35 | X | X | X |
| CEILING DIFFUSERS | | | | | |
| Step-Down - Order one | LARTD30/36S | 45K74 | X | X | X |
| Flush - Order one | LAFD30/36S | 45K75 | X | X | X |
| Transitions (Supply and Return) - Order one | LASRT30/36 | 33K80 | X | X | X |

NOTE - Catalog and model numbers shown are for ordering field installed accessories.

OX - Configure To Order (Factory Installed) or Field Installed

O = Configure To Order (Factory Installed)

X = Field Installed

SPECIFICATIONS LGH, LCH

| General Data | | Nominal Tonnage | 20 Ton | 25 Ton | 25 Ton | 25 Ton |
|---|---------------------------------------|-----------------|--|---------------------------|---------------------------|--------------------------------|
| | | Model Number | 242H4V | 300H4B | 300H4V | 300H4M |
| | | Efficiency Type | High | High | High | High |
| | | Blower Type | Variable Air Volume (VAV) | Constant Air Volume (CAV) | Variable Air Volume (VAV) | MSAV® (Multi-Stage Air Volume) |
| Cooling Performance | Gross Cooling Capacity - Btuh | | 244,000 | 310,000 | 310,000 | 310,000 |
| | Net Cooling Capacity - Btuh | | ¹ 238,000 | ² 300,000 | ² 300,000 | ² 300,000 |
| | AHRI Rated Air Flow - cfm | | 6800 | 8100 | 8100 | 8100 |
| | Total Unit Power - kW | | 19 | 25.4 | 25.8 | 25.8 |
| | EER (Btuh/Watt) | | ¹ 12.5 | ² 11.8 | ² 11.6 | ² 11.6 |
| | IEER (Btuh/Watt) | | ¹ 15.5 | ² 12.5 | ² 14.3 | ² 14.4 |
| | Refrigerant Type | | R-410A | R-410A | R-410A | R-410A |
| | Refrigerant Charge | Circuit 1 | 8 lbs. 0 oz. | 9 lbs. 4 oz. | 8 lbs. 0 oz. | 8 lbs. 0 oz. |
| | | Circuit 2 | 8 lbs. 0 oz. | 9 lbs. 0 oz. | 8 lbs. 0 oz. | 8 lbs. 0 oz. |
| | | Circuit 3 | 8 lbs. 8 oz. | 8 lbs. 12 oz. | 8 lbs. 0 oz. | 8 lbs. 0 oz. |
| | Circuit 4 | 8 lbs. 8 oz. | 8 lbs. 8 oz. | 8 lbs. 8 oz. | 8 lbs. 8 oz. | |
| Electric Heat Available | | | 30-45-60-90-120 kW | | | |
| Compressor Type (number) | | | Scroll (4) | Scroll (4) | Scroll (4) | Scroll (4) |
| Outdoor Coils | Net face area (total) - sq. ft. | | 68.3 | 68.3 | 68.3 | 68.3 |
| Outdoor Coil Fans | Number of rows | | 1 | 1 | 1 | 1 |
| | Fins per inch | | 23 | 23 | 23 | 23 |
| Outdoor Coil Fans | Motor - (No.) horsepower | | (6) 1/3 | (6) 1/3 | (6) 1/3 | (6) 1/3 |
| | Motor rpm | | 1075 | 1075 | 1075 | 1075 |
| | Total Motor watts | | 2500 | 2500 | 2500 | 2500 |
| | Diameter - (No.) in. | | (6) 24 | (6) 24 | (6) 24 | (6) 24 |
| | Number of blades | | 3 | 3 | 3 | 3 |
| | Total Air volume - cfm | | 21,500 | 21,500 | 21,500 | 21,500 |
| Indoor Coils | Net face area (total) - sq. ft. | | 31.40 | 31.40 | 31.40 | 31.40 |
| | Tube diameter - in. | | 3/8 | 3/8 | 3/8 | 3/8 |
| | Number of rows | | 4 | 4 | 4 | 4 |
| | Fins per inch | | 14 | 14 | 14 | 14 |
| | Drain connection - No. and size | | (1) 1 in. NPT | (1) 1 in. NPT | (1) 1 in. NPT | (1) 1 in. NPT |
| Expansion device type | | | Balance port TXV, removable head | | | |
| ³ Indoor Blower and Kit Selection | Nominal motor output | | 5 hp, 7.5 hp, 10 hp | | | |
| | Maximum usable motor output (US Only) | | 5.75 hp, 8.63 hp, 11.5 hp | | | |
| | Motor - Kit kit number | | 5 hp Kit 5 660-810 rpm Kit 6 770-965 rpm Kit 7 570-720 rpm Kit 8 480-630 rpm Kit 9 410-535 rpm 7.5 hp Kit 3 715-880 rpm Kit 4 770-965 rpm 10 hp Kit 1 740-895 rpm Kit 2 870-1045 rpm | | | |
| | Blower wheel nom. D x W - in. | | (2) 18 x 15 | (2) 18 x 15 | (2) 18 x 15 | (2) 18 x 15 |
| Filters | Type of filter | | Fiberglass, disposable | | | |
| | Number and size - in. | | (12) 20 x 20 x 2 | | | |
| Electrical characteristics | | | 208/230V, 460V or 575V - 60 hertz - 3 phase | | | |

NOTE - Net capacity includes evaporator blower motor heat deduction. Gross capacity does not include evaporator blower motor heat deduction.

¹ AHRI Certified to AHRI Standard 340/360; 95°F outdoor air temperature and 80°F db/67°F wb entering evaporator air; minimum external duct static pressure.

² Tested at conditions included in with AHRI Standard 340/360.

³ Using total air volume and system static pressure requirements determine from blower performance tables rpm and motor output required. Maximum usable output of motors furnished are shown. In Canada, nominal motor output is also maximum usable motor output. If motors of comparable output are used, be sure to keep within the service factor limitations outlined on the motor nameplate.

SPECIFICATIONS LGH, LCH

| General Data | | Nominal Tonnage | 30 Ton | 30 Ton | 30 Ton | |
|---|--|-----------------|--|---------------------------|--------------------------------|--------------|
| | | Model Number | 360H4B | 360H4V | 360H4M | |
| | | Efficiency Type | High | High | High | |
| | | Blower Type | Constant Air Volume (CAV) | Variable Air Volume (VAV) | MSAV® (Multi-Stage Air Volume) | |
| Cooling Performance | Gross Cooling Capacity - Btuh | | 370,000 | 370,000 | 370,000 | |
| | ¹ Net Cooling Capacity - Btuh | | 354,000 | 350,000 | 350,000 | |
| | AHRI Rated Air Flow - cfm | | 9600 | 8600 | 8600 | |
| | Total Unit Power - kW | | 32.8 | 32.4 | 32.4 | |
| | ¹ EER (Btuh/Watt) | | 10.8 | 10.8 | 10.8 | |
| | ¹ IEER (Btuh/Watt) | | 11.6 | 13.5 | 14.0 | |
| | Refrigerant Type | | R-410A | R-410A | R-410A | |
| | Refrigerant Charge | Circuit 1 | | 9 lbs. 0 oz. | 8 lbs. 0 oz. | 8 lbs. 0 oz. |
| | | Circuit 2 | | 8 lbs. 0 oz. | 8 lbs. 0 oz. | 8 lbs. 0 oz. |
| Circuit 3 | | | 9 lbs. 0 oz. | 8 lbs. 0 oz. | 8 lbs. 0 oz. | |
| Circuit 4 | | | 7 lbs. 8 oz. | 8 lbs. 0 oz. | 8 lbs. 0 oz. | |
| Electric Heat Available - | | | 30-45-60-90-120 kW | | | |
| Compressor Type (number) | | | Scroll (4) | Scroll (4) | Scroll (4) | |
| Outdoor Coils | Net face area (total) - sq. ft. | | 68.3 | 68.3 | 68.3 | |
| | Number of rows | | 1 | 1 | 1 | |
| | Fins per inch | | 23 | 23 | 23 | |
| Outdoor Coil Fans | Motor - (No.) horsepower | | (6) 1/3 | (6) 1/3 | (6) 1/3 | |
| | Motor rpm | | 1075 | 1075 | 1075 | |
| | Total Motor watts | | 2500 | 2500 | 2500 | |
| | Diameter - (No.) in. | | (6) 24 | (6) 24 | (6) 24 | |
| | Number of blades | | 3 | 3 | 3 | |
| | Total Air volume - cfm | | 21,500 | 21,500 | 21,500 | |
| Indoor Coils | Net face area (total) - sq. ft. | | 31.40 | 31.40 | 31.40 | |
| | Tube diameter - in. | | 3/8 | 3/8 | 3/8 | |
| | Number of rows | | 4 | 4 | 4 | |
| | Fins per inch | | 14 | 14 | 14 | |
| | Drain connection - No. and size | | (1) 1 in. NPT | (1) 1 in. NPT | (1) 1 in. NPT | |
| | Expansion device type | | Balance port TXV, removable head | | | |
| ³ Indoor Blower and Kit Selection | Nominal motor output | | 5 hp, 7.5 hp, 10 hp | | | |
| | Maximum usable motor output (US Only) | | 5.75 hp, 8.63 hp, 11.5 hp | | | |
| | Motor - Kit kit number | | 5 hp Kit 5 660-810 rpm Kit 6 770-965 rpm Kit 7 570-720 rpm Kit 8 480-630 rpm Kit 9 410-535 rpm 7.5 hp Kit 3 715-880 rpm Kit 4 770-965 rpm 10 hp Kit 1 740-895 rpm Kit 2 870-1045 rpm | | | |
| | Blower wheel nom. D x W - in. | | (2) 18 x 15 | (2) 18 x 15 | (2) 18 x 15 | |
| Filters | Type of filter | | Fiberglass, disposable | | | |
| | Number and size - in. | | (12) 20 x 20 x 2 | | | |
| Electrical characteristics | | | 208/230V, 460V or 575V - 60 hertz - 3 phase | | | |

NOTE - Net capacity includes evaporator blower motor heat deduction. Gross capacity does not include evaporator blower motor heat deduction.

¹ AHRI Certified to AHRI Standard 340/360; 95°F outdoor air temperature and 80°F db/67°F wb entering evaporator air; minimum external duct static pressure.

³ Using total air volume and system static pressure requirements determine from blower performance tables rpm and motor output required. Maximum usable output of motors furnished are shown. In Canada, nominal motor output is also maximum usable motor output. If motors of comparable output are used, be sure to keep within the service factor limitations outlined on the motor nameplate.

SPECIFICATIONS - GAS HEAT

| Usage Data | | Model Number | LGH242 LGH300 LGH360 | | |
|--|---------------|--------------|----------------------------|------------|-----------|
| | | | Standard (S) | Medium (M) | High (H) |
| Heat Input Type | | | | | |
| Number of Gas Heat Stages | | | 2 | 2 | 2 |
| Gas Heating Performance (Two-Stage) | Input - Btuh | First Stage | 169,000 | 234,000 | 312,000 |
| | | Second Stage | 260,000 | 360,000 | 480,000 |
| | Output - Btuh | First Stage | --- | --- | --- |
| | | Second Stage | 208,000 | 288,000 | 384,000 |
| ¹ Gas Heating Performance (Four-Stage) | Input - Btuh | First Stage | 84,500 | 117,000 | 156,000 |
| | | Second Stage | 169,000 | 234,000 | 312,000 |
| | | Third Stage | 214,000 | 297,000 | 396,000 |
| | | Fourth Stage | 260,000 | 360,000 | 480,000 |
| | Output - Btuh | First Stage | --- | --- | --- |
| | | Second Stage | --- | --- | --- |
| | | Third Stage | --- | --- | --- |
| | | Fourth Stage | 208,000 | 288,000 | 384,000 |
| Temperature Rise Range - °F | | | 15 - 45 | 30 - 60 | 40 - 70 |
| Thermal Efficiency | | | 80.0% | 80.0% | 80.0% |
| Gas Supply Connections | | | 1 in. npt | 1 in. npt | 1 in. npt |
| Recommended Gas Supply Pressure - in. w.g. | Natural | | 7 | 7 | 7 |
| | LPG/Propane | | 11 | 11 | 11 |

¹ Four-Stage Gas Heating is field configured.

HIGH ALTITUDE DERATE

Units may be installed at altitudes up to 2000 feet above sea level without any modification.

At altitudes above 2000 feet, units must be derated to match gas manifold pressures shown in table below.

At altitudes above 4500 feet unit must be derated 2% for each 1000 feet above sea level.

NOTE – This is the only permissible derate for these units.

TWO-STAGE

| Gas Heat Type (Two-Stage) | Altitude - ft. | Gas Manifold Pressure - in. w.g. | | Input Rate Natural Gas or LPG/Propane - Btuh | |
|---------------------------|------------------------|----------------------------------|-----------------|--|--------------|
| | | Natural Gas | LPG/Propane Gas | First Stage | Second Stage |
| Low (L) | No adjustment required | | | | |
| Standard (S) | 2001 - 4500 | 3.4 | 9.6 | 169,000 | 249,000 |
| Medium (M) | 2001 - 4500 | 3.4 | 9.6 | 234,000 | 345,000 |
| High (H) | 2001 - 4500 | 3.4 | 9.6 | 312,000 | 460,000 |

FOUR-STAGE

| ¹ Gas Heat Type (Four-Stage) | Altitude - ft. | Gas Manifold Pressure - in. w.g. | | Input Rate Natural Gas or LPG/Propane - Btuh | | | |
|---|------------------------|----------------------------------|-----------------|--|--------------|-------------|--------------|
| | | Natural Gas | LPG/Propane Gas | First Stage | Second Stage | Third Stage | Fourth Stage |
| Low (L) | No adjustment required | | | | | | |
| Standard (S) | 2001 - 4500 | 3.4 | 9.6 | 84,000 | 169,000 | 209,000 | 249,000 |
| Medium (M) | 2001 - 4500 | 3.4 | 9.6 | 117,000 | 234,000 | 289,000 | 345,000 |
| High (H) | 2001 - 4500 | 3.4 | 9.6 | 156,000 | 312,000 | 386,000 | 460,000 |

¹ Four-Stage Gas Heating is field configured.

BLOWER DATA

BLOWER TABLE INCLUDES RESISTANCE FOR BASE UNIT ONLY WITH DRY INDOOR COIL & AIR FILTERS IN PLACE FOR ALL UNITS ADD:

- 1 - Wet indoor coil air resistance of selected unit.
- 2 - Any factory installed options air resistance (electric heat, economizer, etc.)
- 3 - Any field installed accessories air resistance (electric heat, duct resistance, diffuser, etc.)

Then determine from blower table blower motor output and drive required.

See page 29 for wet coil and option/accessory air resistance data.

See page 29 for factory installed drive kit specifications.

MINIMUM AIR VOLUME REQUIRED FOR USE WITH OPTIONAL ELECTRIC HEAT

All units require 10,500 cfm minimum air with electric heat.

| Air Volume cfm | TOTAL STATIC PRESSURE - In. w.g. | | | | | | | | | | | | | | | | | | | | | | | | | | | | | |
|-------------------|----------------------------------|------|------|------|------|------|------|------|------|-------|------|-------|------|-------|------|-------|------|-------|------|-------|------|-------|------|-------|------|-------|------|-------|------|-------|
| | 0.20 | | 0.40 | | 0.60 | | 0.80 | | 1.00 | | 1.20 | | 1.40 | | 1.60 | | 1.80 | | 2.00 | | 2.20 | | 2.40 | | 2.60 | | | | | |
| | RPM | BHP | RPM | BHP | RPM | BHP | RPM | BHP | RPM | BHP | RPM | BHP | RPM | BHP | RPM | BHP | RPM | BHP | RPM | BHP | RPM | BHP | RPM | BHP | RPM | BHP | | | | |
| 4000 | 372 | 0.26 | 433 | 0.65 | 497 | 0.99 | 565 | 1.27 | 630 | 1.54 | 687 | 1.79 | 738 | 2.04 | 784 | 2.30 | 824 | 2.56 | 861 | 2.82 | 897 | 3.10 | 932 | 3.40 | 968 | 3.66 | 974 | 4.01 | 980 | 4.30 |
| 4500 | 382 | 0.41 | 441 | 0.79 | 506 | 1.12 | 574 | 1.41 | 638 | 1.69 | 694 | 1.95 | 744 | 2.22 | 790 | 2.50 | 831 | 2.77 | 868 | 3.05 | 903 | 3.35 | 938 | 3.66 | 974 | 3.93 | 980 | 4.30 | 987 | 4.60 |
| 5000 | 392 | 0.56 | 451 | 0.93 | 516 | 1.25 | 584 | 1.55 | 646 | 1.85 | 702 | 2.12 | 751 | 2.41 | 796 | 2.70 | 837 | 3.00 | 874 | 3.30 | 909 | 3.61 | 944 | 3.93 | 980 | 4.22 | 987 | 4.60 | 994 | 4.91 |
| 5500 | 402 | 0.73 | 462 | 1.08 | 527 | 1.40 | 594 | 1.72 | 655 | 2.02 | 710 | 2.31 | 758 | 2.61 | 802 | 2.92 | 843 | 3.24 | 880 | 3.56 | 916 | 3.88 | 951 | 4.22 | 987 | 4.52 | 994 | 4.91 | 1001 | 5.24 |
| 6000 | 414 | 0.89 | 473 | 1.24 | 539 | 1.56 | 605 | 1.90 | 665 | 2.21 | 718 | 2.51 | 766 | 2.83 | 809 | 3.16 | 850 | 3.51 | 887 | 3.84 | 922 | 4.18 | 957 | 4.52 | 994 | 4.85 | 1001 | 5.24 | 1008 | 5.59 |
| 6500 | 426 | 1.07 | 486 | 1.41 | 551 | 1.74 | 616 | 2.10 | 675 | 2.42 | 727 | 2.73 | 774 | 3.07 | 817 | 3.43 | 857 | 3.80 | 894 | 4.15 | 929 | 4.49 | 964 | 4.85 | 1001 | 5.19 | 1008 | 5.59 | 1016 | 5.97 |
| 7000 | 439 | 1.26 | 499 | 1.60 | 565 | 1.93 | 628 | 2.31 | 685 | 2.64 | 737 | 2.97 | 782 | 3.34 | 825 | 3.72 | 864 | 4.11 | 901 | 4.48 | 937 | 4.83 | 971 | 5.19 | 1008 | 5.56 | 1016 | 5.97 | 1025 | 6.37 |
| 7500 | 453 | 1.46 | 513 | 1.79 | 579 | 2.14 | 641 | 2.55 | 696 | 2.88 | 747 | 3.24 | 792 | 3.63 | 833 | 4.04 | 872 | 4.45 | 909 | 4.83 | 945 | 5.20 | 979 | 5.56 | 1016 | 5.97 | 1025 | 6.37 | 1034 | 6.81 |
| 8000 | 467 | 1.66 | 528 | 2.00 | 593 | 2.38 | 653 | 2.81 | 708 | 3.15 | 757 | 3.53 | 801 | 3.95 | 843 | 4.39 | 881 | 4.82 | 918 | 5.22 | 953 | 5.59 | 988 | 5.96 | 1025 | 6.37 | 1034 | 6.81 | 1044 | 7.28 |
| 8500 | 483 | 1.88 | 544 | 2.22 | 608 | 2.65 | 667 | 3.10 | 720 | 3.44 | 768 | 3.85 | 812 | 4.30 | 852 | 4.78 | 890 | 5.22 | 927 | 5.63 | 962 | 6.01 | 997 | 6.39 | 1034 | 6.81 | 1044 | 7.28 | 1055 | 7.78 |
| 9000 | 499 | 2.11 | 561 | 2.47 | 624 | 2.95 | 681 | 3.41 | 733 | 3.76 | 780 | 4.20 | 823 | 4.69 | 862 | 5.19 | 900 | 5.65 | 936 | 6.07 | 972 | 6.46 | 1007 | 6.85 | 1044 | 7.28 | 1055 | 7.78 | 1066 | 8.32 |
| 9500 | 516 | 2.36 | 578 | 2.75 | 640 | 3.26 | 696 | 3.73 | 746 | 4.10 | 792 | 4.58 | 834 | 5.11 | 873 | 5.64 | 910 | 6.12 | 946 | 6.54 | 982 | 6.93 | 1018 | 7.34 | 1055 | 7.78 | 1066 | 8.32 | 1077 | 8.89 |
| 10,000 | 534 | 2.64 | 596 | 3.06 | 657 | 3.60 | 711 | 4.07 | 760 | 4.48 | 805 | 5.00 | 845 | 5.57 | 884 | 6.12 | 921 | 6.61 | 957 | 7.03 | 992 | 7.43 | 1028 | 7.86 | 1066 | 8.32 | 1077 | 8.89 | 1089 | 9.49 |
| 10,500 | 553 | 2.93 | 615 | 3.39 | 674 | 3.95 | 727 | 4.44 | 775 | 4.90 | 817 | 5.46 | 857 | 6.06 | 895 | 6.62 | 932 | 7.12 | 967 | 7.55 | 1003 | 7.96 | 1039 | 8.40 | 1077 | 8.89 | 1089 | 9.49 | 1101 | 10.12 |
| 11,000 | 572 | 3.24 | 634 | 3.74 | 692 | 4.31 | 744 | 4.83 | 789 | 5.35 | 830 | 5.95 | 869 | 6.58 | 907 | 7.16 | 943 | 7.65 | 978 | 8.09 | 1013 | 8.51 | 1050 | 8.98 | 1089 | 9.49 | 1101 | 10.12 | 1112 | 10.77 |
| 11,500 | 592 | 3.58 | 653 | 4.12 | 711 | 4.70 | 760 | 5.27 | 803 | 5.85 | 843 | 6.49 | 881 | 7.13 | 918 | 7.71 | 954 | 8.21 | 989 | 8.65 | 1025 | 9.10 | 1062 | 9.59 | 1101 | 10.12 | 1112 | 10.77 | 1124 | 11.42 |
| 12,000 | 613 | 3.95 | 674 | 4.53 | 729 | 5.14 | 776 | 5.75 | 818 | 6.39 | 857 | 7.06 | 894 | 7.71 | 930 | 8.30 | 965 | 8.80 | 1000 | 9.25 | 1036 | 9.71 | 1073 | 10.22 | 1112 | 10.77 | 1124 | 11.42 | 1135 | 12.17 |
| 12,500 | 635 | 4.37 | 695 | 4.98 | 748 | 5.62 | 792 | 6.29 | 832 | 6.98 | 870 | 7.67 | 906 | 8.33 | 941 | 8.91 | 976 | 9.42 | 1011 | 9.87 | 1048 | 10.35 | 1085 | 10.86 | 1124 | 11.42 | 1135 | 12.17 | 1146 | 12.92 |
| 13,000 | 657 | 4.83 | 715 | 5.50 | 766 | 6.18 | 808 | 6.89 | 847 | 7.61 | 883 | 8.32 | 918 | 8.98 | 953 | 9.56 | 988 | 10.06 | 1023 | 10.52 | 1059 | 11.00 | 1096 | 11.57 | 1135 | 12.17 | 1146 | 12.92 | 1157 | 13.67 |
| 13,500 | 680 | 5.35 | 736 | 6.06 | 784 | 6.78 | 824 | 7.53 | 861 | 8.29 | 896 | 9.00 | 930 | 9.66 | 965 | 10.24 | 1000 | 10.74 | 1035 | 11.20 | 1071 | 11.77 | 1106 | 12.34 | 1146 | 12.92 | 1157 | 13.67 | 1168 | 14.42 |
| 14,000 | 704 | 5.92 | 757 | 6.67 | 801 | 7.44 | 839 | 8.23 | 875 | 9.00 | 909 | 9.72 | 943 | 10.38 | 977 | 10.94 | 1012 | 11.43 | 1047 | 12.26 | 1082 | 12.83 | 1117 | 13.41 | 1152 | 14.00 | 1163 | 15.17 | 1174 | 15.92 |
| 14,500 | 727 | 6.55 | 777 | 7.34 | 818 | 8.16 | 854 | 8.97 | 889 | 9.75 | 922 | 10.48 | 955 | 11.12 | 989 | 11.78 | 1024 | 12.13 | 1059 | 12.96 | 1094 | 13.54 | 1129 | 14.00 | 1164 | 14.57 | 1175 | 15.92 | 1186 | 16.77 |
| 15,000 | 750 | 7.23 | 797 | 8.07 | 834 | 8.92 | 868 | 9.75 | 902 | 10.54 | 935 | 11.26 | 969 | 11.90 | 1003 | 12.52 | 1038 | 13.08 | 1073 | 13.89 | 1108 | 14.49 | 1143 | 15.08 | 1178 | 15.14 | 1189 | 16.77 | 1200 | 17.62 |

BLOWER DATA

DRIVE KIT SPECIFICATIONS

| Motor Efficiency | Nominal hp | Maximum hp | Drive Kit Number | RPM Range |
|------------------|------------|------------|------------------|------------|
| Standard | 5 | 5.75 | 5 | 660 - 810 |
| Standard | 5 | 5.75 | 6 | 770 - 965 |
| Standard | 5 | 5.75 | 7 | 570 - 720 |
| Standard | 5 | 5.75 | 8 | 480 - 630 |
| Standard | 5 | 5.75 | 9 | 410 - 535 |
| Standard | 7.5 | 8.63 | 3 | 715 - 880 |
| Standard | 7.5 | 8.63 | 4 | 770 - 965 |
| Standard | 10 | 11.50 | 1 | 740 - 895 |
| Standard | 10 | 11.50 | 2 | 870 - 1045 |

NOTES

Using total air volume and system static pressure requirements determine from blower performance tables rpm and motor output required. Maximum usable output of motors furnished are shown. In Canada, nominal motor output is also maximum usable motor output. If motors of comparable output are used, be sure to keep within the service factor limitations outlined on the motor nameplate.

For VFD applications, nominal motor output is also maximum usable motor output.

FACTORY INSTALLED OPTIONS/FIELD INSTALLED ACCESSORY AIR RESISTANCE

| Air Volume cfm | Wet Indoor Coil in. w.g. | Electric Heat in. w.g. | Economizer in. w.g. | Filters | | Horizontal Roof Curb in. w.g. |
|----------------|-----------------------------|---------------------------|------------------------|----------|----------|----------------------------------|
| | | | | MERV 8 | MERV 13 | |
| | | | | in. w.g. | in. w.g. | |
| 4000 | 0.04 | 0.01 | 0.00 | 0.00 | 0.00 | 0.04 |
| 4500 | 0.04 | 0.01 | 0.00 | 0.00 | 0.00 | 0.05 |
| 5000 | 0.05 | 0.01 | 0.00 | 0.00 | 0.00 | 0.06 |
| 5500 | 0.06 | 0.02 | 0.01 | 0.00 | 0.01 | 0.07 |
| 6000 | 0.07 | 0.02 | 0.01 | 0.00 | 0.02 | 0.08 |
| 6500 | 0.08 | 0.02 | 0.01 | 0.01 | 0.02 | 0.09 |
| 7000 | 0.09 | 0.03 | 0.02 | 0.01 | 0.03 | 0.10 |
| 7500 | 0.10 | 0.03 | 0.02 | 0.01 | 0.04 | 0.11 |
| 8000 | 0.11 | 0.03 | 0.02 | 0.01 | 0.04 | 0.13 |
| 8500 | 0.12 | 0.04 | 0.03 | 0.01 | 0.04 | 0.15 |
| 9000 | 0.13 | 0.04 | 0.04 | 0.01 | 0.04 | 0.17 |
| 9500 | 0.14 | 0.05 | 0.04 | 0.02 | 0.06 | 0.19 |
| 10,000 | 0.15 | 0.05 | 0.05 | 0.02 | 0.06 | 0.21 |
| 10,500 | 0.16 | 0.06 | 0.06 | 0.02 | 0.06 | 0.24 |
| 11,000 | 0.18 | 0.06 | 0.07 | 0.02 | 0.07 | 0.27 |
| 11,500 | 0.19 | 0.07 | 0.08 | 0.02 | 0.08 | 0.30 |
| 12,000 | 0.20 | 0.07 | 0.10 | 0.02 | 0.08 | 0.33 |
| 12,500 | 0.21 | 0.08 | 0.11 | 0.03 | 0.10 | 0.37 |
| 13,000 | 0.23 | 0.08 | 0.13 | 0.03 | 0.10 | 0.40 |
| 13,500 | 0.24 | 0.09 | 0.14 | 0.03 | 0.11 | 0.44 |
| 14,000 | 0.26 | 0.10 | 0.16 | 0.03 | 0.12 | 0.49 |
| 14,500 | 0.27 | 0.10 | 0.18 | 0.04 | 0.13 | 0.53 |
| 15,000 | 0.29 | 0.11 | 0.21 | 0.04 | 0.13 | 0.58 |

BLOWER DATA

POWER EXHAUST PERFORMANCE - STANDARD STATIC

| Return Duct Negative Static Pressure | Air Volume Exhausted |
|--------------------------------------|----------------------|
| in. w.g. | cfm |
| 0.00 | 12,800 |
| 0.05 | 12,200 |
| 0.10 | 11,500 |
| 0.15 | 10,800 |
| 0.20 | 9900 |
| 0.25 | 9000 |
| 0.30 | 7900 |
| 0.35 | 6750 |
| 0.40 | 5450 |
| 0.45 | 4150 |
| 0.50 | 2900 |

POWER EXHAUST - 50% HIGH STATIC OPERATION

| Air Volume cfm | RETURN DUCT NEGATIVE STATIC PRESSURE - In. w.g. | | | | | | | | | | | | | | | | | | | | | |
|----------------|---|------|------|------|------|------|------|------|------|------|------|------|------|------|------|------|------|------|------|------|-----|------|
| | 0 | | 0.10 | | 0.20 | | 0.30 | | 0.40 | | 0.50 | | 0.60 | | 0.70 | | 0.80 | | 0.90 | | 1.0 | |
| | RPM | BHP | RPM | BHP | RPM | BHP | RPM | BHP | RPM | BHP | RPM | BHP | RPM | BHP | RPM | BHP | RPM | BHP | RPM | BHP | RPM | BHP |
| 4000 | --- | --- | --- | --- | 430 | 0.40 | 475 | 0.45 | 520 | 0.50 | 570 | 0.55 | 615 | 0.65 | 665 | 0.70 | 710 | 0.75 | 755 | 0.85 | --- | --- |
| 4500 | --- | --- | 415 | 0.45 | 460 | 0.55 | 500 | 0.60 | 545 | 0.65 | 585 | 0.70 | 625 | 0.80 | 670 | 0.85 | 710 | 0.95 | 750 | 1.00 | 795 | 1.10 |
| 5000 | 415 | 0.55 | 455 | 0.65 | 490 | 0.70 | 530 | 0.75 | 570 | 0.85 | 605 | 0.90 | 645 | 1.00 | 680 | 1.05 | 720 | 1.15 | 755 | 1.20 | 795 | 1.30 |
| 5500 | 460 | 0.75 | 495 | 0.85 | 525 | 0.90 | 560 | 0.95 | 595 | 1.05 | 630 | 1.10 | 665 | 1.20 | 700 | 1.30 | 735 | 1.35 | 765 | 1.45 | 800 | 1.55 |
| 6000 | 500 | 1.00 | 530 | 1.05 | 565 | 1.15 | 595 | 1.20 | 625 | 1.30 | 660 | 1.40 | 690 | 1.45 | 720 | 1.55 | 750 | 1.65 | 785 | 1.70 | 815 | 1.80 |
| 6500 | 540 | 1.25 | 570 | 1.30 | 600 | 1.40 | 630 | 1.50 | 660 | 1.60 | 685 | 1.65 | 715 | 1.75 | 745 | 1.85 | 775 | 1.95 | 805 | 2.05 | 830 | 2.10 |
| 7000 | 585 | 1.55 | 610 | 1.65 | 635 | 1.70 | 665 | 1.85 | 690 | 1.90 | 720 | 2.00 | 745 | 2.10 | 770 | 2.20 | 800 | 2.30 | 825 | 2.40 | 855 | 2.50 |
| 7500 | 625 | 1.90 | 650 | 2.00 | 675 | 2.10 | 700 | 2.20 | 725 | 2.30 | 750 | 2.40 | 775 | 2.50 | 800 | 2.60 | 825 | 2.70 | 850 | 2.80 | 875 | 2.90 |
| 8000 | 665 | 2.30 | 690 | 2.40 | 715 | 2.55 | 735 | 2.60 | 760 | 2.70 | 785 | 2.85 | 810 | 2.95 | 830 | 3.05 | 855 | 3.15 | 880 | 3.25 | 905 | 3.40 |
| 8500 | 710 | 2.80 | 730 | 2.90 | 755 | 3.00 | 775 | 3.10 | 795 | 3.20 | 820 | 3.35 | 840 | 3.45 | 865 | 3.55 | 885 | 3.65 | 910 | 3.80 | 930 | 3.90 |

POWER EXHAUST - 100% HIGH STATIC OPERATION

| Air Volume cfm | RETURN DUCT NEGATIVE STATIC PRESSURE - In. w.g. | | | | | | | | | | | | | | | | | | | | | |
|----------------|---|------|------|------|------|------|------|------|------|------|------|------|------|------|------|------|------|------|------|------|-----|------|
| | 0 | | 0.10 | | 0.20 | | 0.30 | | 0.40 | | 0.50 | | 0.60 | | 0.70 | | 0.80 | | 0.90 | | 1.0 | |
| | RPM | BHP | RPM | BHP | RPM | BHP | RPM | BHP | RPM | BHP | RPM | BHP | RPM | BHP | RPM | BHP | RPM | BHP | RPM | BHP | RPM | BHP |
| 8500 | 475 | 1.30 | 500 | 1.30 | 525 | 1.40 | 550 | 1.50 | 585 | 1.60 | 625 | 1.75 | 670 | 1.90 | 710 | 2.10 | 745 | 2.30 | 780 | 2.50 | 815 | 2.70 |
| 9000 | 520 | 1.55 | 535 | 1.60 | 550 | 1.65 | 570 | 1.70 | 605 | 1.85 | 640 | 1.95 | 685 | 2.15 | 720 | 2.35 | 760 | 2.55 | 790 | 2.75 | 825 | 3.00 |
| 9500 | 550 | 1.80 | 560 | 1.85 | 575 | 1.90 | 600 | 2.00 | 620 | 2.10 | 655 | 2.20 | 695 | 2.40 | 735 | 2.60 | 770 | 2.80 | 800 | 3.00 | 835 | 3.25 |
| 10,000 | 575 | 2.10 | 590 | 2.15 | 605 | 2.20 | 620 | 2.30 | 645 | 2.40 | 675 | 2.50 | 710 | 2.65 | 745 | 2.85 | 780 | 3.05 | 815 | 3.30 | 845 | 3.50 |
| 10,500 | 605 | 2.45 | 615 | 2.45 | 625 | 2.50 | 645 | 2.60 | 670 | 2.75 | 690 | 2.80 | 725 | 3.00 | 755 | 3.15 | 790 | 3.35 | 825 | 3.60 | 855 | 3.80 |
| 11,000 | 630 | 2.80 | 645 | 2.85 | 660 | 2.95 | 675 | 3.00 | 685 | 3.05 | 715 | 3.20 | 740 | 3.30 | 770 | 3.50 | 805 | 3.70 | 835 | 3.90 | 870 | 4.20 |
| 11,500 | 665 | 3.25 | 675 | 3.30 | 680 | 3.30 | 695 | 3.40 | 715 | 3.50 | 735 | 3.60 | 755 | 3.70 | 785 | 3.85 | 815 | 4.05 | 850 | 4.30 | 880 | 4.50 |
| 12,000 | 685 | 3.60 | 700 | 3.70 | 710 | 3.75 | 725 | 3.85 | 740 | 3.95 | 755 | 4.00 | 780 | 4.15 | 805 | 4.30 | 830 | 4.45 | 860 | 4.65 | 890 | 4.90 |
| 12,500 | 720 | 4.10 | 730 | 4.20 | 740 | 4.25 | 750 | 4.30 | 765 | 4.40 | 780 | 4.50 | 800 | 4.60 | 820 | 4.75 | 845 | 4.90 | 875 | 5.10 | 905 | 5.35 |
| 13,000 | 745 | 4.60 | 750 | 4.65 | 765 | 4.75 | 780 | 4.85 | 790 | 4.90 | 805 | 5.00 | 820 | 5.10 | 840 | 5.25 | 865 | 5.40 | 890 | 5.60 | 915 | 5.80 |
| 13,500 | 775 | 5.15 | 785 | 5.25 | 795 | 5.35 | 805 | 5.40 | 815 | 5.50 | 830 | 5.60 | 845 | 5.70 | 865 | 5.80 | 880 | 5.95 | 905 | 6.10 | 930 | 6.30 |
| 14,000 | 805 | 5.80 | 810 | 5.80 | 820 | 5.90 | 830 | 6.00 | 845 | 6.10 | 855 | 6.20 | 870 | 6.30 | 885 | 6.40 | 905 | 6.55 | 925 | 6.70 | --- | --- |

HIGH STATIC POWER EXHAUST WITH CONSTANT AIR VOLUME – DRIVE KIT SPECIFICATIONS

| Power Exhaust Model No. | Motor HP | Drive Kit Number | RPM Range |
|-------------------------|----------|------------------|-----------|
| LAPEB30/36A (50%) | (2) 2 hp | 1 | 406 - 533 |
| LAPEB30/36B (50%) | (2) 2 hp | 2 | 531 - 731 |
| LAPEB30/36C (50%) | (2) 2 hp | 3 | 731 - 932 |
| LAPEB30/36D (100%) | (3) 2 hp | 1 | 406 - 533 |
| LAPEB30/36E (100%) | (3) 2 hp | 2 | 531 - 731 |
| LAPEB30/36F (100%) | (3) 2 hp | 3 | 731 - 932 |

NOTE - Using total air volume and system static pressure requirements, determine from blower performance tables rpm and motor output required.

BLOWER DATA

CEILING DIFFUSER AIR RESISTANCE - in. w.g.

| Air Volume cfm | Step-Down Diffuser | | | Flush Diffuser |
|-------------------|--------------------|--------------------|-----------------------|----------------|
| | LARTD30/36S | | | LAFD30/36S |
| | 2 Ends Open | 1 Side/2 Ends Open | All Ends & Sides Open | |
| 7500 | 0.37 | 0.31 | 0.25 | 0.29 |
| 8000 | 0.42 | 0.36 | 0.29 | 0.34 |
| 8500 | 0.48 | 0.41 | 0.34 | 0.39 |
| 9000 | 0.55 | 0.47 | 0.39 | 0.44 |
| 9500 | 0.62 | 0.53 | 0.45 | 0.51 |
| 10,000 | 0.70 | 0.60 | 0.51 | 0.57 |
| 10,500 | 0.78 | 0.68 | 0.58 | 0.65 |
| 11,000 | 0.87 | 0.76 | 0.65 | 0.72 |
| 11,500 | 0.97 | 0.85 | 0.73 | 0.81 |
| 12,000 | 1.08 | 0.94 | 0.82 | 0.9 |
| 12,500 | 1.19 | 1.04 | 0.91 | 0.99 |
| 13,000 | 1.30 | 1.15 | 1.00 | 1.10 |
| 13,500 | 1.43 | 1.26 | 1.10 | 1.20 |
| 14,000 | 1.56 | 1.38 | 1.20 | 1.31 |
| 14,500 | 1.69 | 1.50 | 1.31 | 1.43 |
| 15,000 | 1.84 | 1.63 | 1.43 | 1.56 |

CEILING DIFFUSER AIR THROW DATA - ft.

| Air Volume cfm | ¹ Effective Throw Range - ft. | |
|-------------------|--|---------|
| | Step-Down | Flush |
| 9000 | 40 - 47 | 29 - 35 |
| 9500 | 43 - 50 | 33 - 41 |
| 10,000 | 46 - 54 | 37 - 46 |
| 10,500 | 50 - 58 | 42 - 51 |
| 11,000 | 53 - 61 | 46 - 56 |
| 11,500 | 55 - 64 | 50 - 61 |
| 12,000 | 58 - 67 | 54 - 66 |
| 12,500 | 61 - 71 | 58 - 71 |
| 13,000 | 64 - 74 | 62 - 75 |
| 13,500 | 67 - 77 | 66 - 79 |

¹ Throw is the horizontal or vertical distance an airstream travels on leaving the outlet diffuser before the maximum velocity is reduced to 50 ft. per minute. Four sides open.

ELECTRICAL DATA

20 TON

20 TON HIGH EFFICIENCY - VARIABLE AIR VOLUME (VAV)

LCH242H4V

| ¹ Voltage - 60hz | | 208/230V - 3 Ph | | | 460V - 3 Ph | | | 575V - 3 Ph | | |
|---|--|-----------------|------|------|-------------|-----|----|-------------|-----|----|
| Compressor 1 | Rated Load Amps | 13.5 | | | 8 | | | 5 | | |
| | Locked Rotor Amps | 109 | | | 59 | | | 40 | | |
| Compressor 2 | Rated Load Amps | 13.5 | | | 8 | | | 5 | | |
| | Locked Rotor Amps | 109 | | | 59 | | | 40 | | |
| Compressor 3 | Rated Load Amps | 13.5 | | | 8 | | | 5 | | |
| | Locked Rotor Amps | 109 | | | 59 | | | 40 | | |
| Compressor 4 | Rated Load Amps | 13.5 | | | 8 | | | 5 | | |
| | Locked Rotor Amps | 109 | | | 59 | | | 40 | | |
| Outdoor Fan Motors (6) | Full Load Amps (total) | 2.4 (14.4) | | | 1.3 (7.8) | | | 1 (6) | | |
| Standard Power Exhaust (3) 0.33 HP | Full Load Amps (total) | 2.4 (7.2) | | | 1.3 (3.9) | | | 1 (3) | | |
| 50% High Static Power Exhaust (2) 2 HP | Full Load Amps (total) | 7.5 (15) | | | 3.4 (6.8) | | | 2.7 (5.4) | | |
| 100% High Static Power Exhaust (3) 2 HP | Full Load Amps (total) | 7.5 (22.5) | | | 3.4 (10.2) | | | 2.7 (8.1) | | |
| Service Outlet 115V GFI (amps) | | 15 | | | 15 | | | 20 | | |
| Indoor Blower Motor | Horsepower | 5 | 7.5 | 10 | 5 | 7.5 | 10 | 5 | 7.5 | 10 |
| | Full Load Amps | 16.7 | 24.2 | 30.8 | 7.6 | 11 | 14 | 6.1 | 9 | 11 |
| ² Maximum Overcurrent Protection | Unit Only | 100 | 110 | 125 | 50 | 60 | 70 | 35 | 45 | 50 |
| | With (3) 0.33 HP Standard Power Exhaust | 110 | 125 | 125 | 60 | 60 | 70 | 40 | 45 | 50 |
| | With 50% High Static Power Exhaust (2) 2 HP | 110 | 125 | 150 | 60 | 70 | 70 | 45 | 50 | 50 |
| | With 100% High Static Power Exhaust (3) 2 HP | 125 | 125 | 150 | 60 | 70 | 80 | 45 | 50 | 50 |
| ³ Minimum Circuit Ampacity | Unit Only | 90 | 99 | 107 | 50 | 54 | 58 | 34 | 38 | 40 |
| | With (3) 0.33 HP Standard Power Exhaust | 97 | 106 | 115 | 54 | 58 | 62 | 37 | 41 | 43 |
| | With 50% High Static Power Exhaust (2) 2 HP | 105 | 114 | 122 | 57 | 61 | 65 | 40 | 43 | 46 |
| | With 100% High Static Power Exhaust (3) 2 HP | 112 | 122 | 130 | 60 | 64 | 68 | 42 | 46 | 48 |

NOTE - All units have a minimum Short Circuit Current Rating (SCCR) of 5000 amps.

¹ Extremes of operating range are plus and minus 10% of line voltage.² HACR type breaker or fuse.³ Refer to National or Canadian Electrical Code manual to determine wire, fuse and disconnect size requirements.

ELECTRIC HEAT DATA

20 TON

20 TON HIGH EFFICIENCY - VARIABLE AIR VOLUME (VAV)

LCH242H4V

| ¹ Voltage - 60hz - 3 phase | | | 208/230V - 3 Ph | | | | | | 460V - 3 Ph | | | 575V - 3 Ph | | |
|---|---|--------|------------------|------------------|------------------|------------------|------------------|------------------|-------------|------|------|-------------|------|------|
| Indoor Blower Motor | Horsepower | | 5 | | 7.5 | | 10 | | 5 | 7.5 | 10 | 5 | 7.5 | 10 |
| | Electric Heat Voltage | | 208V | 240V | 208V | 240V | 208V | 240V | 480V | 480V | 480V | 600V | 600V | 600V |
| ² Maximum Overcurrent Protection | Unit+ Electric Heat | 30 kW | ⁴ 100 | 125 | ⁴ 110 | 125 | ⁴ 125 | 150 | 60 | 60 | 70 | 45 | 50 | 50 |
| | | 45 kW | ⁴ 150 | 175 | ⁴ 150 | 175 | 175 | 175 | 80 | 90 | 90 | 70 | 70 | 70 |
| | | 60 kW | ⁴ 150 | 175 | 175 | 175 | ⁴ 175 | 200 | 90 | 90 | 90 | 70 | 70 | 80 |
| | | 90 kW | ⁴ 225 | 250 | ⁴ 225 | 250 | ⁴ 250 | ⁴ 300 | 125 | 125 | 150 | 100 | 100 | 110 |
| | | 120 kW | ⁴ 300 | ⁴ 350 | ⁴ 300 | ⁴ 350 | ⁴ 300 | ⁴ 350 | 175 | 175 | 175 | 125 | 150 | 150 |
| | Unit+ Electric Heat and Standard Power Exhaust (3) 0.33 HP | 30 kW | ⁴ 110 | 125 | ⁴ 125 | 150 | 150 | 150 | 60 | 70 | 70 | 50 | 60 | 60 |
| | | 45 kW | ⁴ 150 | 175 | 175 | 175 | ⁴ 175 | 200 | 90 | 90 | 100 | 70 | 70 | 80 |
| | | 60 kW | 175 | 175 | ⁴ 175 | 200 | ⁴ 175 | 200 | 90 | 100 | 100 | 70 | 80 | 80 |
| | | 90 kW | ⁴ 225 | 250 | ⁴ 250 | ⁴ 300 | ⁴ 250 | ⁴ 300 | 125 | 150 | 150 | 100 | 110 | 110 |
| | | 120 kW | ⁴ 300 | ⁴ 350 | ⁴ 300 | ⁴ 350 | ⁴ 300 | ⁴ 350 | 175 | 175 | 175 | 150 | 150 | 150 |
| | Unit+ Electric Heat and 50% High Static Power Exhaust (2) 2 HP | 30 kW | ⁴ 125 | 150 | 150 | 150 | 150 | 150 | 70 | 70 | 80 | 60 | 60 | 60 |
| | | 45 kW | 175 | 175 | ⁴ 175 | 200 | ⁴ 175 | 200 | 90 | 90 | 100 | 70 | 80 | 80 |
| | | 60 kW | ⁴ 175 | 200 | ⁴ 175 | 200 | ⁴ 200 | 225 | 100 | 100 | 100 | 80 | 80 | 80 |
| | | 90 kW | ⁴ 250 | ⁴ 300 | ⁴ 250 | ⁴ 300 | ⁴ 250 | ⁴ 300 | 150 | 150 | 150 | 110 | 110 | 110 |
| | | 120 kW | ⁴ 300 | ⁴ 350 | ⁴ 300 | ⁴ 350 | 350 | ⁴ 350 | 175 | 175 | 175 | 150 | 150 | 150 |
| | Unit+ Electric Heat and 100% High Static Power Exhaust (3) 2 HP | 30 kW | 150 | 150 | 150 | 150 | ⁴ 150 | 175 | 70 | 80 | 80 | 60 | 60 | 60 |
| | | 45 kW | ⁴ 175 | 200 | 200 | 200 | ⁴ 200 | 225 | 90 | 100 | 100 | 80 | 80 | 80 |
| | | 60 kW | ⁴ 175 | 200 | ⁴ 200 | 225 | ⁴ 200 | 225 | 100 | 100 | 110 | 80 | 80 | 90 |
| | | 90 kW | ⁴ 250 | ⁴ 300 | ⁴ 250 | ⁴ 300 | 300 | ⁴ 300 | 150 | 150 | 150 | 110 | 110 | 125 |
| | | 120 kW | ⁴ 300 | ⁴ 350 | 350 | ⁴ 350 | ⁴ 350 | ⁴ 400 | 175 | 175 | 175 | 150 | 150 | 150 |
| ³ Minimum Circuit Ampacity | Unit+ Electric Heat | 30 kW | 100 | 112 | 109 | 121 | 117 | 129 | 55 | 59 | 63 | 44 | 48 | 50 |
| | | 45 kW | 139 | 157 | 148 | 166 | 156 | 174 | 78 | 82 | 86 | 62 | 66 | 68 |
| | | 60 kW | 146 | 166 | 156 | 175 | 164 | 183 | 82 | 86 | 90 | 66 | 69 | 72 |
| | | 90 kW | 209 | 238 | 218 | 247 | 227 | 256 | 118 | 123 | 126 | 95 | 98 | 101 |
| | | 120 kW | 272 | 310 | 281 | 319 | 289 | 328 | 154 | 159 | 162 | 124 | 127 | 130 |
| | Unit+ Electric Heat and Standard Power Exhaust (3) 0.33 HP | 30 kW | 109 | 121 | 118 | 130 | 126 | 138 | 60 | 64 | 68 | 48 | 52 | 54 |
| | | 45 kW | 148 | 166 | 157 | 175 | 165 | 183 | 83 | 87 | 91 | 66 | 70 | 72 |
| | | 60 kW | 155 | 175 | 165 | 184 | 173 | 192 | 87 | 91 | 95 | 70 | 73 | 76 |
| | | 90 kW | 218 | 247 | 227 | 256 | 236 | 265 | 123 | 127 | 131 | 98 | 102 | 105 |
| | | 120 kW | 281 | 319 | 290 | 328 | 298 | 337 | 159 | 163 | 167 | 127 | 131 | 133 |
| | Unit+ Electric Heat and 50% High Static Power Exhaust (2) 2 HP | 30 kW | 118 | 130 | 128 | 140 | 136 | 148 | 64 | 68 | 72 | 51 | 55 | 57 |
| | | 45 kW | 157 | 175 | 167 | 185 | 175 | 193 | 86 | 90 | 94 | 69 | 73 | 75 |
| | | 60 kW | 165 | 184 | 175 | 194 | 183 | 202 | 91 | 95 | 99 | 73 | 76 | 79 |
| | | 90 kW | 228 | 257 | 237 | 266 | 245 | 274 | 127 | 131 | 135 | 101 | 105 | 108 |
| | | 120 kW | 290 | 329 | 300 | 338 | 308 | 346 | 163 | 167 | 171 | 130 | 134 | 136 |
| | Unit+ Electric Heat and 100% High Static Power Exhaust (3) 2 HP | 30 kW | 128 | 140 | 137 | 149 | 145 | 157 | 68 | 72 | 76 | 54 | 58 | 60 |
| | | 45 kW | 167 | 185 | 176 | 194 | 184 | 202 | 90 | 95 | 98 | 72 | 76 | 79 |
| | | 60 kW | 175 | 194 | 184 | 203 | 192 | 211 | 95 | 99 | 103 | 76 | 80 | 82 |
| | | 90 kW | 237 | 266 | 247 | 275 | 255 | 284 | 131 | 135 | 139 | 105 | 108 | 111 |
| | | 120 kW | 300 | 338 | 309 | 348 | 317 | 356 | 167 | 171 | 175 | 134 | 137 | 140 |

¹ Extremes of operating range are plus and minus 10% of line voltage.

² HACR type breaker or fuse.

³ Refer to National or Canadian Electrical Code manual to determine wire, fuse and disconnect size requirements.

⁴ Factory installed circuit breaker not available.

ELECTRICAL DATA

25 TON

25 TON HIGH EFFICIENCY - CONSTANT AIR VOLUME (CAV)

LCH300H4B

| ¹ Voltage - 60hz | | 208/230V - 3 Ph | | | 460V - 3 Ph | | | 575V - 3 Ph | | |
|---|--|-----------------|------|------|-------------|-----|----|-------------|-----|----|
| Compressor 1 | Rated Load Amps | 22.4 | | | 10.6 | | | 7.7 | | |
| | Locked Rotor Amps | 149 | | | 75 | | | 54 | | |
| Compressor 2 | Rated Load Amps | 22.4 | | | 10.6 | | | 7.7 | | |
| | Locked Rotor Amps | 149 | | | 75 | | | 54 | | |
| Compressor 3 | Rated Load Amps | 22.4 | | | 10.6 | | | 7.7 | | |
| | Locked Rotor Amps | 149 | | | 75 | | | 54 | | |
| Compressor 4 | Rated Load Amps | 22.4 | | | 10.6 | | | 7.7 | | |
| | Locked Rotor Amps | 149 | | | 75 | | | 54 | | |
| Outdoor Fan Motors (6) | Full Load Amps | 2.4 | | | 1.3 | | | 1 | | |
| | (total) | (14.4) | | | (7.8) | | | (6) | | |
| Standard Power Exhaust (3) 0.33 HP | Full Load Amps | 2.4 | | | 1.3 | | | 1 | | |
| | (total) | (7.2) | | | (3.9) | | | (3) | | |
| 50% High Static Power Exhaust (2) 2 HP | Full Load Amps | 7.5 | | | 3.4 | | | 2.7 | | |
| | (total) | (15) | | | (6.8) | | | (5.4) | | |
| 100% High Static Power Exhaust (3) 2 HP | Full Load Amps | 7.5 | | | 3.4 | | | 2.7 | | |
| | (total) | (22.5) | | | (10.2) | | | (8.1) | | |
| Service Outlet 115V GFI (amps) | | 15 | | | 15 | | | 20 | | |
| Indoor Blower Motor | Horsepower | 5 | 7.5 | 10 | 5 | 7.5 | 10 | 5 | 7.5 | 10 |
| | Full Load Amps | 16.7 | 24.2 | 30.8 | 7.6 | 11 | 14 | 6.1 | 9 | 11 |
| ² Maximum Overcurrent Protection | Unit Only | 150 | 150 | 150 | 70 | 70 | 80 | 50 | 50 | 60 |
| | With (3) 0.33 HP Standard Power Exhaust | 150 | 150 | 150 | 70 | 70 | 80 | 60 | 60 | 60 |
| | With 50% High Static Power Exhaust (2) 2 HP | 150 | 150 | 175 | 70 | 80 | 80 | 60 | 60 | 60 |
| | With 100% High Static Power Exhaust (3) 2 HP | 150 | 175 | 175 | 80 | 80 | 90 | 60 | 60 | 60 |
| ³ Minimum Circuit Ampacity | Unit Only | 127 | 135 | 143 | 61 | 64 | 68 | 45 | 49 | 51 |
| | With (3) 0.33 HP Standard Power Exhaust | 128 | 134 | 142 | 62 | 65 | 68 | 46 | 48 | 52 |
| | With 50% High Static Power Exhaust (2) 2 HP | 142 | 150 | 158 | 68 | 71 | 75 | 51 | 54 | 56 |
| | With 100% High Static Power Exhaust (3) 2 HP | 149 | 157 | 165 | 71 | 75 | 78 | 53 | 57 | 59 |

NOTE - All units have a minimum Short Circuit Current Rating (SCCR) of 5000 amps.

¹ Extremes of operating range are plus and minus 10% of line voltage.

² HACR type breaker or fuse.

³ Refer to National or Canadian Electrical Code manual to determine wire, fuse and disconnect size requirements.

ELECTRIC HEAT DATA

25 TON

25 TON HIGH EFFICIENCY - CONSTANT AIR VOLUME (CAV)

LCH300H4B

| ¹ Voltage - 60hz - 3 phase | | | 208/230V - 3 Ph | | | | | | 460V - 3 Ph | | | 575V - 3 Ph | | |
|---|---|------------------|------------------|------------------|------------------|------------------|------------------|------------------|-------------|------|------|-------------|------|------|
| Indoor Blower Motor | Horsepower | | 5 | | 7.5 | | 10 | | 5 | 7.5 | 10 | 5 | 7.5 | 10 |
| | Electric Heat Voltage | | 208V | 240V | 208V | 240V | 208V | 240V | 480V | 480V | 480V | 600V | 600V | 600V |
| ² Maximum Overcurrent Protection | Unit+ Electric Heat | 30 kW | 150 | 150 | 150 | 150 | 150 | 150 | 70 | 70 | 80 | 50 | 50 | 60 |
| | | 45 kW | ⁴ 150 | 175 | ⁴ 150 | 175 | 175 | 175 | 80 | 90 | 90 | 70 | 70 | 70 |
| | | 60 kW | ⁴ 150 | 175 | 175 | 175 | ⁴ 175 | 200 | 90 | 90 | 90 | 70 | 70 | 80 |
| | | 90 kW | ⁴ 225 | 250 | ⁴ 225 | 250 | ⁴ 250 | ⁴ 300 | 125 | 125 | 150 | 100 | 100 | 110 |
| | | 120 kW | ⁴ 300 | ⁴ 350 | ⁴ 300 | ⁴ 350 | ⁴ 300 | ⁴ 350 | 175 | 175 | 175 | 125 | 150 | 150 |
| | Unit+ Electric Heat and Standard Power Exhaust (3) 0.33 HP | 30 kW | 150 | 150 | 150 | 150 | 150 | 150 | 70 | 70 | 70 | 50 | 50 | 60 |
| | | 45 kW | ⁴ 150 | 175 | ⁴ 150 | 175 | 175 | 175 | 80 | 90 | 90 | 70 | 70 | 70 |
| | | 60 kW | ⁴ 150 | 175 | 175 | 175 | ⁴ 175 | 200 | 90 | 90 | 100 | 70 | 70 | 80 |
| | | 90 kW | ⁴ 225 | 250 | ⁴ 225 | 250 | ⁴ 250 | ⁴ 300 | 125 | 125 | 150 | 100 | 100 | 110 |
| | | 120 kW | ⁴ 300 | ⁴ 350 | ⁴ 300 | ⁴ 350 | ⁴ 300 | ⁴ 350 | 175 | 175 | 175 | 125 | 150 | 150 |
| | Unit+ Electric Heat and 50% High Static Power Exhaust (2) 2 HP | 30 kW | 150 | 150 | 150 | 150 | 175 | 175 | 70 | 80 | 80 | 60 | 60 | 60 |
| | | 45 kW | 175 | 175 | ⁴ 175 | 200 | ⁴ 175 | 200 | 90 | 90 | 100 | 70 | 80 | 80 |
| | | 60 kW | ⁴ 175 | 200 | ⁴ 175 | 200 | ⁴ 200 | 225 | 100 | 100 | 100 | 80 | 80 | 80 |
| | | 90 kW | ⁴ 250 | ⁴ 300 | ⁴ 250 | ⁴ 300 | ⁴ 250 | ⁴ 300 | 150 | 150 | 150 | 110 | 110 | 110 |
| | | 120 kW | ⁴ 300 | ⁴ 350 | ⁴ 300 | ⁴ 350 | 350 | ⁴ 350 | 175 | 175 | 175 | 150 | 150 | 150 |
| Unit+ Electric Heat and 100% High Static Power Exhaust (3) 2 HP | 30 kW | 150 | 150 | 175 | 175 | 175 | 175 | 80 | 80 | 90 | 60 | 60 | 60 | |
| | 45 kW | ⁴ 175 | 200 | 200 | 200 | ⁴ 200 | 225 | 90 | 100 | 100 | 80 | 80 | 80 | |
| | 60 kW | ⁴ 175 | 200 | ⁴ 200 | 225 | ⁴ 200 | 225 | 100 | 100 | 110 | 80 | 80 | 90 | |
| | 90 kW | ⁴ 250 | ⁴ 300 | ⁴ 250 | ⁴ 300 | 300 | ⁴ 300 | 150 | 150 | 150 | 110 | 110 | 125 | |
| | 120 kW | ⁴ 300 | ⁴ 350 | 350 | ⁴ 350 | ⁴ 350 | ⁴ 400 | 175 | 175 | 175 | 150 | 150 | 150 | |
| ³ Minimum Circuit Ampacity | Unit+ Electric Heat | 30 kW | 127 | 127 | 135 | 135 | 143 | 143 | 61 | 64 | 68 | 45 | 49 | 51 |
| | | 45 kW | 139 | 157 | 148 | 166 | 156 | 174 | 78 | 82 | 86 | 62 | 66 | 68 |
| | | 60 kW | 146 | 166 | 156 | 175 | 164 | 183 | 82 | 86 | 90 | 66 | 69 | 72 |
| | | 90 kW | 209 | 238 | 218 | 247 | 227 | 256 | 118 | 123 | 126 | 95 | 98 | 101 |
| | | 120 kW | 272 | 310 | 281 | 319 | 289 | 328 | 154 | 159 | 162 | 124 | 127 | 130 |
| | Unit+ Electric Heat and Standard Power Exhaust (3) 0.33 HP | 30 kW | 128 | 128 | 134 | 134 | 142 | 142 | 62 | 65 | 68 | 46 | 48 | 52 |
| | | 45 kW | 140 | 158 | 148 | 166 | 157 | 175 | 79 | 83 | 87 | 63 | 66 | 70 |
| | | 60 kW | 148 | 167 | 155 | 175 | 165 | 184 | 84 | 87 | 91 | 67 | 70 | 73 |
| | | 90 kW | 210 | 239 | 218 | 247 | 227 | 256 | 120 | 123 | 127 | 96 | 98 | 102 |
| | | 120 kW | 273 | 311 | 281 | 319 | 290 | 328 | 156 | 159 | 163 | 125 | 127 | 131 |
| | Unit+ Electric Heat and 50% High Static Power Exhaust (2) 2 HP | 30 kW | 142 | 142 | 150 | 150 | 158 | 158 | 68 | 71 | 75 | 51 | 55 | 57 |
| | | 45 kW | 157 | 175 | 167 | 185 | 175 | 193 | 86 | 90 | 94 | 69 | 73 | 75 |
| | | 60 kW | 165 | 184 | 175 | 194 | 183 | 202 | 91 | 95 | 99 | 73 | 76 | 79 |
| | | 90 kW | 228 | 257 | 237 | 266 | 245 | 274 | 127 | 131 | 135 | 101 | 105 | 108 |
| | | 120 kW | 290 | 329 | 300 | 338 | 308 | 346 | 163 | 167 | 171 | 130 | 134 | 136 |
| | Unit+ Electric Heat and 100% High Static Power Exhaust (3) 2 HP | 30 kW | 149 | 149 | 157 | 157 | 165 | 165 | 71 | 75 | 78 | 54 | 58 | 60 |
| | | 45 kW | 167 | 185 | 176 | 194 | 184 | 202 | 90 | 95 | 98 | 72 | 76 | 79 |
| | | 60 kW | 175 | 194 | 184 | 203 | 192 | 211 | 95 | 99 | 103 | 76 | 80 | 82 |
| | | 90 kW | 237 | 266 | 247 | 275 | 255 | 284 | 131 | 135 | 139 | 105 | 108 | 111 |
| | | 120 kW | 300 | 338 | 309 | 348 | 317 | 356 | 167 | 171 | 175 | 134 | 137 | 140 |

¹ Extremes of operating range are plus and minus 10% of line voltage.

² HACR type breaker or fuse.

³ Refer to National or Canadian Electrical Code manual to determine wire, fuse and disconnect size requirements.

⁴ Factory installed circuit breaker not available.

ELECTRICAL DATA

25 TON

25 TON HIGH EFFICIENCY - VARIABLE AND MULTI-STAGE AIR VOLUME

LCH300H4V,M

| ¹ Voltage - 60hz | | 208/230V - 3 Ph | | | 460V - 3 Ph | | | 575V - 3 Ph | | |
|---|--|-----------------|------|------|-------------|-----|----|-------------|-----|----|
| Compressor 1 | Rated Load Amps | 22.4 | | | 10.6 | | | 7.7 | | |
| | Locked Rotor Amps | 149 | | | 75 | | | 54 | | |
| Compressor 2 | Rated Load Amps | 22.4 | | | 10.6 | | | 7.7 | | |
| | Locked Rotor Amps | 149 | | | 75 | | | 54 | | |
| Compressor 3 | Rated Load Amps | 22.4 | | | 10.6 | | | 7.7 | | |
| | Locked Rotor Amps | 149 | | | 75 | | | 54 | | |
| Compressor 4 | Rated Load Amps | 22.4 | | | 10.6 | | | 7.7 | | |
| | Locked Rotor Amps | 149 | | | 75 | | | 54 | | |
| Outdoor Fan Motors (6) | Full Load Amps | 2.4 | | | 1.3 | | | 1 | | |
| | (total) | (14.4) | | | (7.8) | | | (6) | | |
| Standard Power Exhaust (3) 0.33 HP | Full Load Amps | 2.4 | | | 1.3 | | | 1 | | |
| | (total) | (7.2) | | | (3.9) | | | (3) | | |
| 50% High Static Power Exhaust (2) 2 HP | Full Load Amps | 7.5 | | | 3.4 | | | 2.7 | | |
| | (total) | (15) | | | (6.8) | | | (5.4) | | |
| 100% High Static Power Exhaust (3) 2 HP | Full Load Amps | 7.5 | | | 3.4 | | | 2.7 | | |
| | (total) | (22.5) | | | (10.2) | | | (8.1) | | |
| Service Outlet 115V GFI (amps) | | 15 | | | 15 | | | 20 | | |
| Indoor Blower Motor | Horsepower | 5 | 7.5 | 10 | 5 | 7.5 | 10 | 5 | 7.5 | 10 |
| | Full Load Amps | 16.7 | 24.2 | 30.8 | 7.6 | 11 | 14 | 6.1 | 9 | 11 |
| ² Maximum Overcurrent Protection | Unit Only | 150 | 150 | 150 | 70 | 70 | 80 | 50 | 50 | 60 |
| | With (3) 0.33 HP Standard Power Exhaust | 150 | 150 | 175 | 70 | 70 | 80 | 50 | 60 | 60 |
| | With 50% High Static Power Exhaust (2) 2 HP | 150 | 150 | 175 | 70 | 80 | 80 | 60 | 60 | 60 |
| | With 100% High Static Power Exhaust (3) 2 HP | 150 | 175 | 175 | 80 | 80 | 90 | 60 | 60 | 60 |
| ³ Minimum Circuit Ampacity | Unit Only | 127 | 135 | 143 | 61 | 64 | 68 | 45 | 49 | 51 |
| | With (3) 0.33 HP Standard Power Exhaust | 134 | 142 | 150 | 65 | 68 | 72 | 48 | 52 | 54 |
| | With 50% High Static Power Exhaust (2) 2 HP | 142 | 150 | 158 | 68 | 71 | 75 | 51 | 54 | 56 |
| | With 100% High Static Power Exhaust (3) 2 HP | 149 | 157 | 165 | 71 | 75 | 78 | 53 | 57 | 59 |

NOTE - All units have a minimum Short Circuit Current Rating (SCCR) of 5000 amps.

¹ Extremes of operating range are plus and minus 10% of line voltage.² HACR type breaker or fuse.³ Refer to National or Canadian Electrical Code manual to determine wire, fuse and disconnect size requirements.

ELECTRIC HEAT DATA

25 TON

25 TON HIGH EFFICIENCY - VARIABLE AND MULTI-STAGE AIR VOLUME

LCH300H4V,M

| ¹ Voltage - 60hz - 3 phase | | | 208/230V - 3 Ph | | | | | | 460V - 3 Ph | | | 575V - 3 Ph | | |
|---|---|------------------|------------------|------------------|------------------|------------------|------------------|------------------|-------------|------|------|-------------|------|------|
| Indoor Blower Motor | Horsepower | | 5 | | 7.5 | | 10 | | 5 | 7.5 | 10 | 5 | 7.5 | 10 |
| | Electric Heat Voltage | | 208V | 240V | 208V | 240V | 208V | 240V | 480V | 480V | 480V | 600V | 600V | 600V |
| ² Maximum Overcurrent Protection | Unit+ Electric Heat | 30 kW | 150 | 150 | 150 | 150 | 150 | 150 | 70 | 70 | 80 | 50 | 50 | 60 |
| | | 45 kW | ⁴ 150 | 175 | ⁴ 150 | 175 | 175 | 175 | 80 | 90 | 90 | 70 | 70 | 70 |
| | | 60 kW | ⁴ 150 | 175 | 175 | 175 | ⁴ 175 | 200 | 90 | 90 | 90 | 70 | 70 | 80 |
| | | 90 kW | ⁴ 225 | 250 | ⁴ 225 | 250 | ⁴ 250 | ⁴ 300 | 125 | 125 | 150 | 100 | 100 | 110 |
| | | 120 kW | ⁴ 300 | ⁴ 350 | ⁴ 300 | ⁴ 350 | ⁴ 300 | ⁴ 350 | 175 | 175 | 175 | 125 | 150 | 150 |
| | Unit+ Electric Heat and Standard Power Exhaust (3) 0.33 HP | 30 kW | 150 | 150 | 150 | 150 | 175 | 175 | 70 | 70 | 80 | 50 | 60 | 60 |
| | | 45 kW | ⁴ 150 | 175 | 175 | 175 | ⁴ 175 | 200 | 90 | 90 | 100 | 70 | 70 | 80 |
| | | 60 kW | 175 | 175 | ⁴ 175 | 200 | ⁴ 175 | 200 | 90 | 100 | 100 | 70 | 80 | 80 |
| | | 90 kW | ⁴ 225 | 250 | ⁴ 250 | ⁴ 300 | ⁴ 250 | ⁴ 300 | 125 | 150 | 150 | 100 | 110 | 110 |
| | | 120 kW | ⁴ 300 | ⁴ 350 | ⁴ 300 | ⁴ 350 | ⁴ 300 | ⁴ 350 | 175 | 175 | 175 | 150 | 150 | 150 |
| | Unit+ Electric Heat and 50% High Static Power Exhaust (2) 2 HP | 30 kW | 150 | 150 | 150 | 150 | 175 | 175 | 70 | 80 | 80 | 60 | 60 | 60 |
| | | 45 kW | 175 | 175 | ⁴ 175 | 200 | ⁴ 175 | 200 | 90 | 90 | 100 | 70 | 80 | 80 |
| | | 60 kW | ⁴ 175 | 200 | ⁴ 175 | 200 | ⁴ 200 | 225 | 100 | 100 | 100 | 80 | 80 | 80 |
| | | 90 kW | ⁴ 250 | ⁴ 300 | ⁴ 250 | ⁴ 300 | ⁴ 250 | ⁴ 300 | 150 | 150 | 150 | 110 | 110 | 110 |
| | | 120 kW | ⁴ 300 | ⁴ 350 | ⁴ 300 | ⁴ 350 | 350 | ⁴ 350 | 175 | 175 | 175 | 150 | 150 | 150 |
| Unit+ Electric Heat and 100% High Static Power Exhaust (3) 2 HP | 30 kW | 150 | 150 | 175 | 175 | 175 | 175 | 80 | 80 | 90 | 60 | 60 | 60 | |
| | 45 kW | ⁴ 175 | 200 | 200 | 200 | ⁴ 200 | 225 | 90 | 100 | 100 | 80 | 80 | 80 | |
| | 60 kW | ⁴ 175 | 200 | ⁴ 200 | 225 | ⁴ 200 | 225 | 100 | 100 | 110 | 80 | 80 | 90 | |
| | 90 kW | ⁴ 250 | ⁴ 300 | ⁴ 250 | ⁴ 300 | 300 | ⁴ 300 | 150 | 150 | 150 | 110 | 110 | 125 | |
| | 120 kW | ⁴ 300 | ⁴ 350 | 350 | ⁴ 350 | ⁴ 350 | ⁴ 400 | 175 | 175 | 175 | 150 | 150 | 150 | |
| ³ Minimum Circuit Ampacity | Unit+ Electric Heat | 30 kW | 127 | 127 | 135 | 135 | 143 | 143 | 61 | 64 | 68 | 45 | 49 | 51 |
| | | 45 kW | 139 | 157 | 148 | 166 | 156 | 174 | 78 | 82 | 86 | 62 | 66 | 68 |
| | | 60 kW | 146 | 166 | 156 | 175 | 164 | 183 | 82 | 86 | 90 | 66 | 69 | 72 |
| | | 90 kW | 209 | 238 | 218 | 247 | 227 | 256 | 118 | 123 | 126 | 95 | 98 | 101 |
| | | 120 kW | 272 | 310 | 281 | 319 | 289 | 328 | 154 | 159 | 162 | 124 | 127 | 130 |
| | Unit+ Electric Heat and Standard Power Exhaust (3) 0.33 HP | 30 kW | 134 | 134 | 142 | 142 | 150 | 150 | 65 | 68 | 72 | 48 | 52 | 54 |
| | | 45 kW | 148 | 166 | 157 | 175 | 165 | 183 | 83 | 87 | 91 | 66 | 70 | 72 |
| | | 60 kW | 155 | 175 | 165 | 184 | 173 | 192 | 87 | 91 | 95 | 70 | 73 | 76 |
| | | 90 kW | 218 | 247 | 227 | 256 | 236 | 265 | 123 | 127 | 131 | 98 | 102 | 105 |
| | | 120 kW | 281 | 319 | 290 | 328 | 298 | 337 | 159 | 163 | 167 | 127 | 131 | 133 |
| | Unit+ Electric Heat and 50% High Static Power Exhaust (2) 2 HP | 30 kW | 142 | 142 | 150 | 150 | 158 | 158 | 68 | 71 | 75 | 51 | 55 | 57 |
| | | 45 kW | 157 | 175 | 167 | 185 | 175 | 193 | 86 | 90 | 94 | 69 | 73 | 75 |
| | | 60 kW | 165 | 184 | 175 | 194 | 183 | 202 | 91 | 95 | 99 | 73 | 76 | 79 |
| | | 90 kW | 228 | 257 | 237 | 266 | 245 | 274 | 127 | 131 | 135 | 101 | 105 | 108 |
| | | 120 kW | 290 | 329 | 300 | 338 | 308 | 346 | 163 | 167 | 171 | 130 | 134 | 136 |
| | Unit+ Electric Heat and 100% High Static Power Exhaust (3) 2 HP | 30 kW | 149 | 149 | 157 | 157 | 165 | 165 | 71 | 75 | 78 | 54 | 58 | 60 |
| | | 45 kW | 167 | 185 | 176 | 194 | 184 | 202 | 90 | 95 | 98 | 72 | 76 | 79 |
| | | 60 kW | 175 | 194 | 184 | 203 | 192 | 211 | 95 | 99 | 103 | 76 | 80 | 82 |
| | | 90 kW | 237 | 266 | 247 | 275 | 255 | 284 | 131 | 135 | 139 | 105 | 108 | 111 |
| | | 120 kW | 300 | 338 | 309 | 348 | 317 | 356 | 167 | 171 | 175 | 134 | 137 | 140 |

¹ Extremes of operating range are plus and minus 10% of line voltage.

² HACR type breaker or fuse.

³ Refer to National or Canadian Electrical Code manual to determine wire, fuse and disconnect size requirements.

⁴ Factory installed circuit breaker not available.

ELECTRICAL DATA

30 TON

30 TON HIGH EFFICIENCY - CONSTANT AIR VOLUME (CAV)

LCH360H4B

| ¹ Voltage - 60hz | | 208/230V - 3 Ph | | | 460V - 3 Ph | | | 575V - 3 Ph | | |
|---|--|-----------------|------|------|-------------|-----|----|-------------|-----|----|
| Compressor 1 | Rated Load Amps | 25 | | | 12.2 | | | 9 | | |
| | Locked Rotor Amps | 164 | | | 100 | | | 78 | | |
| Compressor 2 | Rated Load Amps | 25 | | | 12.2 | | | 9 | | |
| | Locked Rotor Amps | 164 | | | 100 | | | 78 | | |
| Compressor 3 | Rated Load Amps | 25 | | | 12.2 | | | 9 | | |
| | Locked Rotor Amps | 164 | | | 100 | | | 78 | | |
| Compressor 4 | Rated Load Amps | 25 | | | 12.2 | | | 9 | | |
| | Locked Rotor Amps | 164 | | | 100 | | | 78 | | |
| Outdoor Fan Motors (6) | Full Load Amps | 2.4 | | | 1.3 | | | 1 | | |
| | (total) | (14.4) | | | (7.8) | | | (6) | | |
| Standard Power Exhaust (3) 0.33 HP | Full Load Amps | 2.4 | | | 1.3 | | | 1 | | |
| | (total) | (7.2) | | | (3.9) | | | (3) | | |
| 50% High Static Power Exhaust (2) 2 HP | Full Load Amps | 7.5 | | | 3.4 | | | 2.7 | | |
| | (total) | (15) | | | (6.8) | | | (5.4) | | |
| 100% High Static Power Exhaust (3) 2 HP | Full Load Amps | 7.5 | | | 3.4 | | | 2.7 | | |
| | (total) | (22.5) | | | (10.2) | | | (8.1) | | |
| Service Outlet 115V GFI (amps) | | 15 | | | 15 | | | 20 | | |
| Indoor Blower Motor | Horsepower | 5 | 7.5 | 10 | 5 | 7.5 | 10 | 5 | 7.5 | 10 |
| | Full Load Amps | 16.7 | 24.2 | 30.8 | 7.6 | 11 | 14 | 6.1 | 9 | 11 |
| ² Maximum Overcurrent Protection | Unit Only | 150 | 150 | 175 | 70 | 80 | 80 | 60 | 60 | 60 |
| | With (3) 0.33 HP Standard Power Exhaust | 150 | 175 | 175 | 80 | 80 | 90 | 60 | 60 | 60 |
| | With 50% High Static Power Exhaust (2) 2 HP | 175 | 175 | 175 | 80 | 80 | 90 | 60 | 60 | 70 |
| | With 100% High Static Power Exhaust (3) 2 HP | 175 | 175 | 200 | 80 | 90 | 90 | 60 | 70 | 70 |
| ³ Minimum Circuit Ampacity | Unit Only | 138 | 145 | 153 | 68 | 71 | 75 | 51 | 54 | 56 |
| | With (3) 0.33 HP Standard Power Exhaust | 145 | 153 | 161 | 72 | 75 | 78 | 54 | 57 | 59 |
| | With 50% High Static Power Exhaust (2) 2 HP | 153 | 160 | 168 | 75 | 78 | 81 | 56 | 59 | 62 |
| | With 100% High Static Power Exhaust (3) 2 HP | 160 | 168 | 176 | 78 | 81 | 85 | 59 | 62 | 64 |

NOTE - All units have a minimum Short Circuit Current Rating (SCCR) of 5000 amps.

¹ Extremes of operating range are plus and minus 10% of line voltage.² HACR type breaker or fuse.³ Refer to National or Canadian Electrical Code manual to determine wire, fuse and disconnect size requirements.

ELECTRIC HEAT DATA

30 TON

30 TON HIGH EFFICIENCY - CONSTANT AIR VOLUME (CAV)

LCH360H4B

| ¹ Voltage - 60hz - 3 phase | | | 208/230V - 3 Ph | | | | | | 460V - 3 Ph | | | 575V - 3 Ph | | |
|---|---|------------------|------------------|------------------|------------------|------------------|------------------|------------------|-------------|------|------|-------------|------|------|
| Indoor Blower Motor | Horsepower | | 5 | | 7.5 | | 10 | | 5 | 7.5 | 10 | 5 | 7.5 | 10 |
| | Electric Heat Voltage | | 208V | 240V | 208V | 240V | 208V | 240V | 480V | 480V | 480V | 600V | 600V | 600V |
| ² Maximum Overcurrent Protection | Unit+ Electric Heat | 30 kW | 150 | 150 | 150 | 150 | 175 | 175 | 70 | 80 | 80 | 60 | 60 | 60 |
| | | 45 kW | ⁴ 150 | 175 | ⁴ 150 | 175 | 175 | 175 | 80 | 90 | 90 | 70 | 70 | 70 |
| | | 60 kW | ⁴ 150 | 175 | 175 | 175 | ⁴ 175 | 200 | 90 | 90 | 90 | 70 | 70 | 80 |
| | | 90 kW | ⁴ 225 | 250 | ⁴ 225 | 250 | ⁴ 250 | ⁴ 300 | 125 | 125 | 150 | 100 | 100 | 110 |
| | | 120 kW | ⁴ 300 | ⁴ 350 | ⁴ 300 | ⁴ 350 | ⁴ 300 | ⁴ 350 | 175 | 175 | 175 | 125 | 150 | 150 |
| | Unit+ Electric Heat and Standard Power Exhaust (3) 0.33 HP | 30 kW | 150 | 150 | 175 | 175 | 175 | 175 | 80 | 80 | 90 | 60 | 60 | 60 |
| | | 45 kW | ⁴ 150 | 175 | 175 | 175 | ⁴ 175 | 200 | 90 | 90 | 100 | 70 | 70 | 80 |
| | | 60 kW | 175 | 175 | ⁴ 175 | 200 | ⁴ 175 | 200 | 90 | 100 | 100 | 70 | 80 | 80 |
| | | 90 kW | ⁴ 225 | 250 | ⁴ 250 | ⁴ 300 | ⁴ 250 | ⁴ 300 | 125 | 150 | 150 | 100 | 110 | 110 |
| | | 120 kW | ⁴ 300 | ⁴ 350 | ⁴ 300 | ⁴ 350 | ⁴ 300 | ⁴ 350 | 175 | 175 | 175 | 150 | 150 | 150 |
| | Unit+ Electric Heat and 50% High Static Power Exhaust (2) 2 HP | 30 kW | 175 | 175 | 175 | 175 | 175 | 175 | 80 | 80 | 90 | 60 | 60 | 70 |
| | | 45 kW | 175 | 175 | ⁴ 175 | 200 | ⁴ 175 | 200 | 90 | 90 | 100 | 70 | 80 | 80 |
| | | 60 kW | ⁴ 175 | 200 | ⁴ 175 | 200 | ⁴ 200 | 225 | 100 | 100 | 100 | 80 | 80 | 80 |
| | | 90 kW | ⁴ 250 | ⁴ 300 | ⁴ 250 | ⁴ 300 | ⁴ 250 | ⁴ 300 | 150 | 150 | 150 | 110 | 110 | 110 |
| | | 120 kW | ⁴ 300 | ⁴ 350 | ⁴ 300 | ⁴ 350 | 350 | ⁴ 350 | 175 | 175 | 175 | 150 | 150 | 150 |
| Unit+ Electric Heat and 100% High Static Power Exhaust (3) 2 HP | 30 kW | 175 | 175 | 175 | 175 | 200 | 200 | 80 | 90 | 90 | 60 | 70 | 70 | |
| | 45 kW | ⁴ 175 | 200 | 200 | 200 | ⁴ 200 | 225 | 90 | 100 | 100 | 80 | 80 | 80 | |
| | 60 kW | ⁴ 175 | 200 | ⁴ 200 | 225 | ⁴ 200 | 225 | 100 | 100 | 110 | 80 | 80 | 90 | |
| | 90 kW | ⁴ 250 | ⁴ 300 | ⁴ 250 | ⁴ 300 | 300 | ⁴ 300 | 150 | 150 | 150 | 110 | 110 | 125 | |
| | 120 kW | ⁴ 300 | ⁴ 350 | 350 | ⁴ 350 | ⁴ 350 | ⁴ 400 | 175 | 175 | 175 | 150 | 150 | 150 | |
| ³ Minimum Circuit Ampacity | Unit+ Electric Heat | 30 kW | 138 | 138 | 145 | 145 | 153 | 153 | 68 | 71 | 75 | 51 | 54 | 56 |
| | | 45 kW | 139 | 157 | 148 | 166 | 156 | 174 | 78 | 82 | 86 | 62 | 66 | 68 |
| | | 60 kW | 146 | 166 | 156 | 175 | 164 | 183 | 82 | 86 | 90 | 66 | 69 | 72 |
| | | 90 kW | 209 | 238 | 218 | 247 | 227 | 256 | 118 | 123 | 126 | 95 | 98 | 101 |
| | | 120 kW | 272 | 310 | 281 | 319 | 289 | 328 | 154 | 159 | 162 | 124 | 127 | 130 |
| | Unit+ Electric Heat and Standard Power Exhaust (3) 0.33 HP | 30 kW | 145 | 145 | 153 | 153 | 161 | 161 | 72 | 75 | 78 | 54 | 57 | 59 |
| | | 45 kW | 148 | 166 | 157 | 175 | 165 | 183 | 83 | 87 | 91 | 66 | 70 | 72 |
| | | 60 kW | 155 | 175 | 165 | 184 | 173 | 192 | 87 | 91 | 95 | 70 | 73 | 76 |
| | | 90 kW | 218 | 247 | 227 | 256 | 236 | 265 | 123 | 127 | 131 | 98 | 102 | 105 |
| | | 120 kW | 281 | 319 | 290 | 328 | 298 | 337 | 159 | 163 | 167 | 127 | 131 | 133 |
| | Unit+ Electric Heat and 50% High Static Power Exhaust (2) 2 HP | 30 kW | 153 | 153 | 160 | 160 | 168 | 168 | 75 | 78 | 81 | 56 | 59 | 62 |
| | | 45 kW | 157 | 175 | 167 | 185 | 175 | 193 | 86 | 90 | 94 | 69 | 73 | 75 |
| | | 60 kW | 165 | 184 | 175 | 194 | 183 | 202 | 91 | 95 | 99 | 73 | 76 | 79 |
| | | 90 kW | 228 | 257 | 237 | 266 | 245 | 274 | 127 | 131 | 135 | 101 | 105 | 108 |
| | | 120 kW | 290 | 329 | 300 | 338 | 308 | 346 | 163 | 167 | 171 | 130 | 134 | 136 |
| | Unit+ Electric Heat and 100% High Static Power Exhaust (3) 2 HP | 30 kW | 160 | 160 | 168 | 168 | 176 | 176 | 78 | 81 | 85 | 59 | 62 | 64 |
| | | 45 kW | 167 | 185 | 176 | 194 | 184 | 202 | 90 | 95 | 98 | 72 | 76 | 79 |
| | | 60 kW | 175 | 194 | 184 | 203 | 192 | 211 | 95 | 99 | 103 | 76 | 80 | 82 |
| | | 90 kW | 237 | 266 | 247 | 275 | 255 | 284 | 131 | 135 | 139 | 105 | 108 | 111 |
| | | 120 kW | 300 | 338 | 309 | 348 | 317 | 356 | 167 | 171 | 175 | 134 | 137 | 140 |

¹ Extremes of operating range are plus and minus 10% of line voltage.

² HACR type breaker or fuse.

³ Refer to National or Canadian Electrical Code manual to determine wire, fuse and disconnect size requirements.

⁴ Factory installed circuit breaker not available.

ELECTRICAL DATA

30 TON

30 TON HIGH EFFICIENCY - VARIABLE AND MULTI-STAGE AIR VOLUME

LCH360H4V,M

| ¹ Voltage - 60hz | | 208/230V - 3 Ph | | | 460V - 3 Ph | | | 575V - 3 Ph | | |
|---|--|------------------------|------|------|--------------------|-----|----|--------------------|-----|----|
| Compressor 1 | Rated Load Amps | 25 | | | 12.2 | | | 9 | | |
| | Locked Rotor Amps | 164 | | | 100 | | | 78 | | |
| Compressor 2 | Rated Load Amps | 25 | | | 12.2 | | | 9 | | |
| | Locked Rotor Amps | 164 | | | 100 | | | 78 | | |
| Compressor 3 | Rated Load Amps | 25 | | | 12.2 | | | 9 | | |
| | Locked Rotor Amps | 164 | | | 100 | | | 78 | | |
| Compressor 4 | Rated Load Amps | 25 | | | 12.2 | | | 9 | | |
| | Locked Rotor Amps | 164 | | | 100 | | | 78 | | |
| Outdoor Fan Motors (6) | Full Load Amps | 2.4 | | | 1.3 | | | 1 | | |
| | (total) | (14.4) | | | (7.8) | | | (6) | | |
| Standard Power Exhaust (3) 0.33 HP | Full Load Amps | 2.4 | | | 1.3 | | | 1 | | |
| | (total) | (7.2) | | | (3.9) | | | (3) | | |
| 50% High Static Power Exhaust (2) 2 HP | | 7.5 (15) | | | 3.4 (6.8) | | | 2.7 (5.4) | | |
| 100% High Static Power Exhaust (3) 2 HP | | 7.5 (22.5) | | | 3.4 (10.2) | | | 2.7 (8.1) | | |
| Service Outlet 115V GFI (amps) | | 15 | | | 15 | | | 20 | | |
| Indoor Blower Motor | Horsepower | 5 | 7.5 | 10 | 5 | 7.5 | 10 | 5 | 7.5 | 10 |
| | Full Load Amps | 16.7 | 24.2 | 30.8 | 7.6 | 11 | 14 | 6.1 | 9 | 11 |
| ² Maximum Overcurrent Protection | Unit Only | 150 | 150 | 175 | 70 | 80 | 80 | 60 | 60 | 60 |
| | With (3) 0.33 HP Standard Power Exhaust | 150 | 175 | 175 | 80 | 80 | 90 | 60 | 60 | 60 |
| | With 50% High Static Power Exhaust (2) 2 HP | 175 | 175 | 175 | 80 | 80 | 90 | 60 | 60 | 70 |
| | With 100% High Static Power Exhaust (3) 2 HP | 175 | 175 | 200 | 80 | 90 | 90 | 60 | 70 | 70 |
| ³ Minimum Circuit Ampacity | Unit Only | 138 | 145 | 153 | 68 | 71 | 75 | 51 | 54 | 56 |
| | With (3) 0.33 HP Standard Power Exhaust | 145 | 153 | 161 | 72 | 75 | 78 | 54 | 57 | 59 |
| | With 50% High Static Power Exhaust (2) 2 HP | 153 | 160 | 168 | 75 | 78 | 81 | 56 | 59 | 62 |
| | With 100% High Static Power Exhaust (3) 2 HP | 160 | 168 | 176 | 78 | 81 | 85 | 59 | 62 | 64 |

NOTE - All units have a minimum Short Circuit Current Rating (SCCR) of 5000 amps.

¹ Extremes of operating range are plus and minus 10% of line voltage.

² HACR type breaker or fuse.

³ Refer to National or Canadian Electrical Code manual to determine wire, fuse and disconnect size requirements.

ELECTRIC HEAT DATA

30 TON

30 TON HIGH EFFICIENCY - VARIABLE AND MULTI-STAGE AIR VOLUME

LCH360H4V,M

| ¹ Voltage - 60hz - 3 phase | | | 208/230V - 3 Ph | | | | | 460V - 3 Ph | | | 575V - 3 Ph | | | |
|---|---|------------------|------------------|------------------|------------------|------------------|------------------|------------------|------|------|-------------|------|------|------|
| Indoor Blower Motor | Horsepower | | 5 | | 7.5 | | 10 | 5 | 7.5 | 10 | 5 | 7.5 | 10 | |
| Electric Heat Voltage | | | 208V | 240V | 208V | 240V | 208V | 240V | 480V | 480V | 480V | 600V | 600V | 600V |
| ² Maximum Overcurrent Protection | Unit+ Electric Heat | 30 kW | 150 | 150 | 150 | 150 | 175 | 175 | 70 | 80 | 80 | 60 | 60 | 60 |
| | | 45 kW | ⁴ 150 | 175 | ⁴ 150 | 175 | 175 | 175 | 80 | 90 | 90 | 70 | 70 | 70 |
| | | 60 kW | ⁴ 150 | 175 | 175 | 175 | ⁴ 175 | 200 | 90 | 90 | 90 | 70 | 70 | 80 |
| | | 90 kW | ⁴ 225 | 250 | ⁴ 225 | 250 | ⁴ 250 | ⁴ 300 | 125 | 125 | 150 | 100 | 100 | 110 |
| | | 120 kW | ⁴ 300 | ⁴ 350 | ⁴ 300 | ⁴ 350 | ⁴ 300 | ⁴ 350 | 175 | 175 | 175 | 125 | 150 | 150 |
| | Unit+ Electric Heat and Standard Power Exhaust (3) 0.33 HP | 30 kW | 150 | 150 | 175 | 175 | 175 | 175 | 80 | 80 | 90 | 60 | 60 | 60 |
| | | 45 kW | ⁴ 150 | 175 | 175 | 175 | ⁴ 175 | 200 | 90 | 90 | 100 | 70 | 70 | 80 |
| | | 60 kW | 175 | 175 | ⁴ 175 | 200 | ⁴ 175 | 200 | 90 | 100 | 100 | 70 | 80 | 80 |
| | | 90 kW | ⁴ 225 | 250 | ⁴ 250 | ⁴ 300 | ⁴ 250 | ⁴ 300 | 125 | 150 | 150 | 100 | 110 | 110 |
| | | 120 kW | ⁴ 300 | ⁴ 350 | ⁴ 300 | ⁴ 350 | ⁴ 300 | ⁴ 350 | 175 | 175 | 175 | 150 | 150 | 150 |
| | Unit+ Electric Heat and 50% High Static Power Exhaust (2) 2 HP | 30 kW | 175 | 175 | 175 | 175 | 175 | 175 | 80 | 80 | 90 | 60 | 60 | 70 |
| | | 45 kW | 175 | 175 | ⁴ 175 | 200 | ⁴ 175 | 200 | 90 | 90 | 100 | 70 | 80 | 80 |
| | | 60 kW | ⁴ 175 | 200 | ⁴ 175 | 200 | ⁴ 200 | 225 | 100 | 100 | 100 | 80 | 80 | 80 |
| | | 90 kW | ⁴ 250 | ⁴ 300 | ⁴ 250 | ⁴ 300 | ⁴ 250 | ⁴ 300 | 150 | 150 | 150 | 110 | 110 | 110 |
| | | 120 kW | ⁴ 300 | ⁴ 350 | ⁴ 300 | ⁴ 350 | 350 | ⁴ 350 | 175 | 175 | 175 | 150 | 150 | 150 |
| Unit+ Electric Heat and 100% High Static Power Exhaust (3) 2 HP | 30 kW | 175 | 175 | 175 | 175 | 200 | 200 | 80 | 90 | 90 | 60 | 70 | 70 | |
| | 45 kW | ⁴ 175 | 200 | 200 | 200 | ⁴ 200 | 225 | 90 | 100 | 100 | 80 | 80 | 80 | |
| | 60 kW | ⁴ 175 | 200 | ⁴ 200 | 225 | ⁴ 200 | 225 | 100 | 100 | 110 | 80 | 80 | 90 | |
| | 90 kW | ⁴ 250 | ⁴ 300 | ⁴ 250 | ⁴ 300 | 300 | ⁴ 300 | 150 | 150 | 150 | 110 | 110 | 125 | |
| | 120 kW | ⁴ 300 | ⁴ 350 | 350 | ⁴ 350 | ⁴ 350 | ⁴ 400 | 175 | 175 | 175 | 150 | 150 | 150 | |
| ³ Minimum Circuit Ampacity | Unit+ Electric Heat | 30 kW | 138 | 138 | 145 | 145 | 153 | 153 | 68 | 71 | 75 | 51 | 54 | 56 |
| | | 45 kW | 139 | 157 | 148 | 166 | 156 | 174 | 78 | 82 | 86 | 62 | 66 | 68 |
| | | 60 kW | 146 | 166 | 156 | 175 | 164 | 183 | 82 | 86 | 90 | 66 | 69 | 72 |
| | | 90 kW | 209 | 238 | 218 | 247 | 227 | 256 | 118 | 123 | 126 | 95 | 98 | 101 |
| | | 120 kW | 272 | 310 | 281 | 319 | 289 | 328 | 154 | 159 | 162 | 124 | 127 | 130 |
| | Unit+ Electric Heat and Standard Power Exhaust (3) 0.33 HP | 30 kW | 145 | 145 | 153 | 153 | 161 | 161 | 72 | 75 | 78 | 54 | 57 | 59 |
| | | 45 kW | 148 | 166 | 157 | 175 | 165 | 183 | 83 | 87 | 91 | 66 | 70 | 72 |
| | | 60 kW | 155 | 175 | 165 | 184 | 173 | 192 | 87 | 91 | 95 | 70 | 73 | 76 |
| | | 90 kW | 218 | 247 | 227 | 256 | 236 | 265 | 123 | 127 | 131 | 98 | 102 | 105 |
| | | 120 kW | 281 | 319 | 290 | 328 | 298 | 337 | 159 | 163 | 167 | 127 | 131 | 133 |
| | Unit+ Electric Heat and 50% High Static Power Exhaust (2) 2 HP | 30 kW | 153 | 153 | 160 | 160 | 168 | 168 | 75 | 78 | 81 | 56 | 59 | 62 |
| | | 45 kW | 157 | 175 | 167 | 185 | 175 | 193 | 86 | 90 | 94 | 69 | 73 | 75 |
| | | 60 kW | 165 | 184 | 175 | 194 | 183 | 202 | 91 | 95 | 99 | 73 | 76 | 79 |
| | | 90 kW | 228 | 257 | 237 | 266 | 245 | 274 | 127 | 131 | 135 | 101 | 105 | 108 |
| | | 120 kW | 290 | 329 | 300 | 338 | 308 | 346 | 163 | 167 | 171 | 130 | 134 | 136 |
| | Unit+ Electric Heat and 100% High Static Power Exhaust (3) 2 HP | 30 kW | 160 | 160 | 168 | 168 | 176 | 176 | 78 | 81 | 85 | 59 | 62 | 64 |
| | | 45 kW | 167 | 185 | 176 | 194 | 184 | 202 | 90 | 95 | 98 | 72 | 76 | 79 |
| | | 60 kW | 175 | 194 | 184 | 203 | 192 | 211 | 95 | 99 | 103 | 76 | 80 | 82 |
| | | 90 kW | 237 | 266 | 247 | 275 | 255 | 284 | 131 | 135 | 139 | 105 | 108 | 111 |
| | | 120 kW | 300 | 338 | 309 | 348 | 317 | 356 | 167 | 171 | 175 | 134 | 137 | 140 |

¹ Extremes of operating range are plus and minus 10% of line voltage.

² HACR type breaker or fuse.

³ Refer to National or Canadian Electrical Code manual to determine wire, fuse and disconnect size requirements.

⁴ Factory installed circuit breaker not available.

ELECTRIC HEAT CAPACITIES

| Volts Input | 30 kW | | | 45 kW | | | 60 kW | | | 90 kW | | | 120 kW | | |
|-------------|----------|-------------|---------------|----------|-------------|---------------|----------|-------------|---------------|----------|-------------|---------------|----------|-------------|---------------|
| | kW Input | Btuh Output | No. of Stages | kW Input | Btuh Output | No. of Stages | kW Input | Btuh Output | No. of Stages | kW Input | Btuh Output | No. of Stages | kW Input | Btuh Output | No. of Stages |
| 208 | 22.5 | 76,800 | 1 | 33.8 | 115,300 | 2 | 45.0 | 153,600 | 2 | 67.6 | 230,700 | 2 | 90.2 | 307,800 | 2 |
| 220 | 25.2 | 86,000 | 1 | 37.8 | 129,000 | 2 | 50.4 | 172,000 | 2 | 75.6 | 258,000 | 2 | 100.8 | 344,000 | 2 |
| 230 | 27.5 | 93,900 | 1 | 41.3 | 141,000 | 2 | 55.1 | 188,000 | 2 | 82.7 | 282,200 | 2 | 110.2 | 376,100 | 2 |
| 240 | 30.0 | 102,400 | 1 | 45.0 | 153,600 | 2 | 60.0 | 204,800 | 2 | 90.0 | 307,100 | 2 | 120.0 | 409,500 | 2 |
| 440 | 25.2 | 86,000 | 1 | 37.8 | 129,000 | 2 | 50.4 | 172,000 | 2 | 75.6 | 258,000 | 2 | 100.8 | 344,000 | 2 |
| 460 | 27.5 | 93,900 | 1 | 41.3 | 141,000 | 2 | 55.1 | 188,000 | 2 | 82.7 | 282,200 | 2 | 110.2 | 376,100 | 2 |
| 480 | 30.0 | 102,400 | 1 | 45.0 | 153,600 | 2 | 60.0 | 204,800 | 2 | 90.0 | 307,100 | 2 | 120.0 | 409,500 | 2 |
| 550 | 25.2 | 86,000 | 1 | 37.8 | 129,000 | 2 | 50.4 | 172,000 | 2 | 75.6 | 258,000 | 2 | 100.8 | 344,000 | 2 |
| 575 | 27.5 | 93,900 | 1 | 41.3 | 141,000 | 2 | 55.1 | 188,000 | 2 | 82.7 | 282,200 | 2 | 110.2 | 376,100 | 2 |
| 600 | 30.0 | 102,400 | 1 | 45.0 | 153,600 | 2 | 60.0 | 204,800 | 2 | 90.0 | 307,100 | 2 | 120.0 | 409,500 | 2 |

LGH/LCH PARTS ARRANGEMENT

Note: LGH shown; LCH will have electric heat in the same location as gas heat.

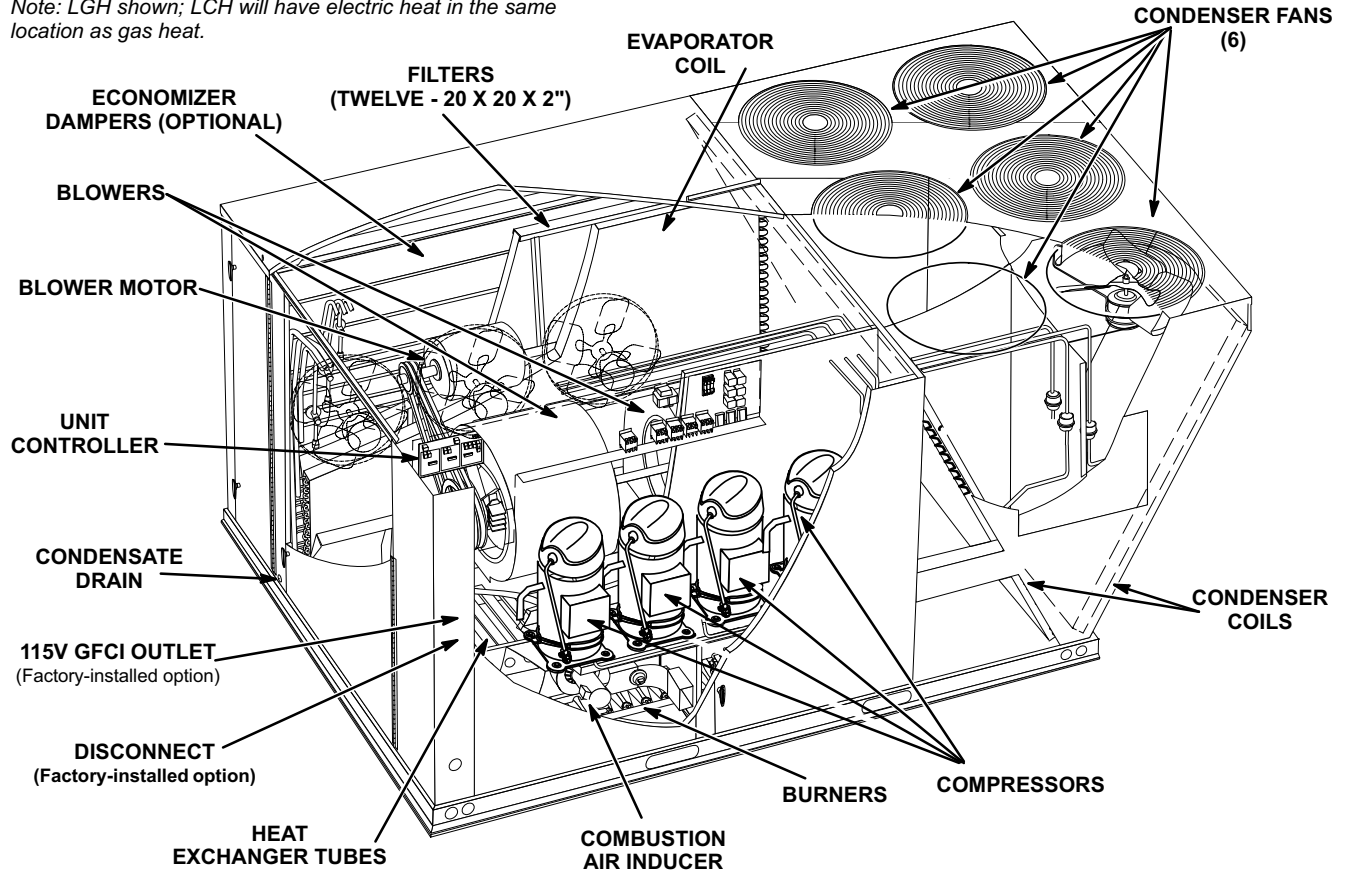
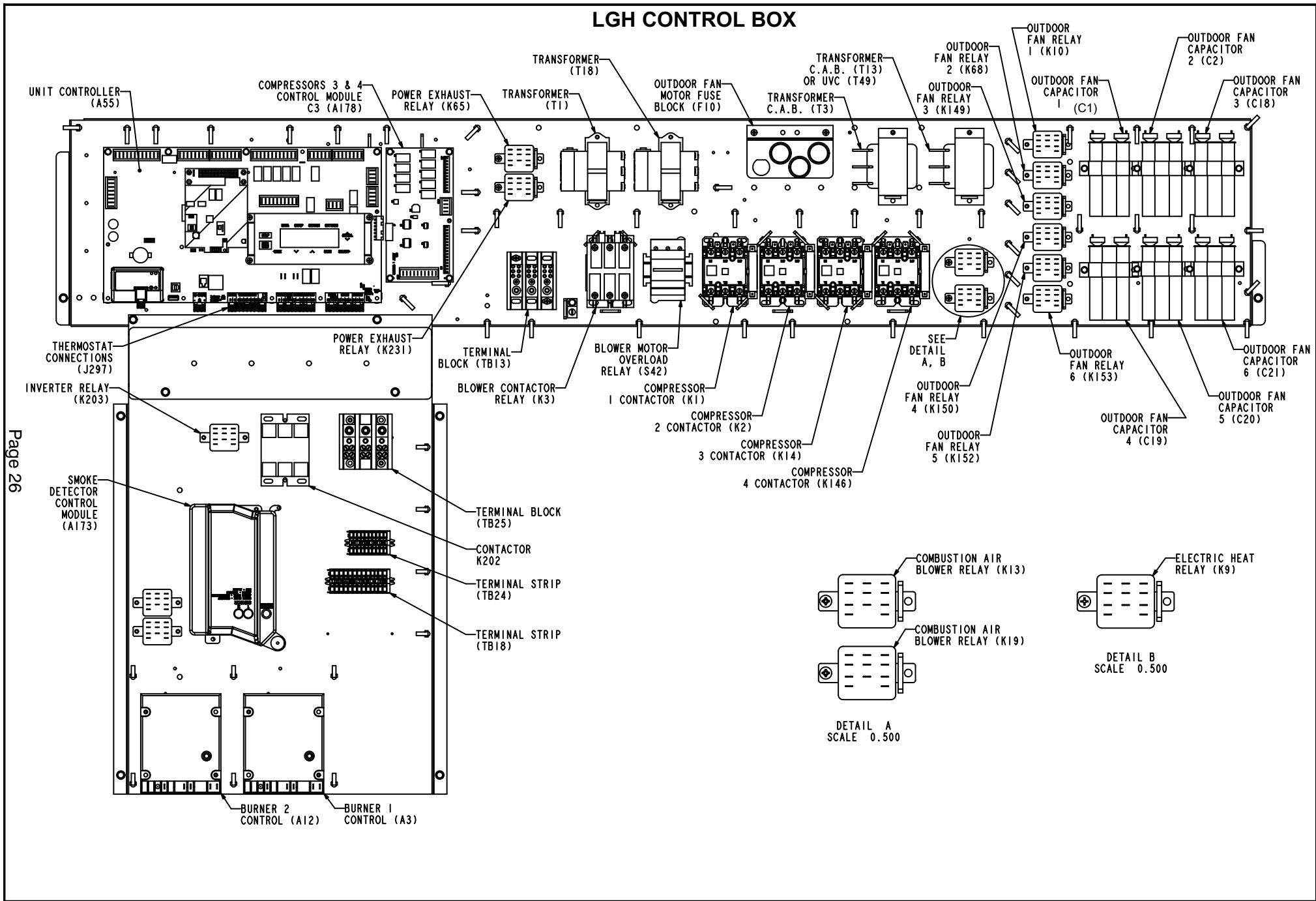

FIGURE 1



Page 26

FIGURE 2

I-UNIT COMPONENTS

ELECTROSTATIC DISCHARGE (ESD)

Precautions and Procedures



Units are configured to order units (CTO). Unit components are shown in figures 1. All units come standard with hinged unit panels. The unit panels may be held open with the door rod located inside the unit. All L1, L2, and L3 wiring is color coded; L1 is red, L2 is yellow, and L3 is blue.

A-Control Box Components

Control box components are shown in figure 2. The control box is located in the upper left portion of the compressor compartment.

1-Disconnect Switch S48 (Optional all units)

All units may be equipped with an optional disconnect switch S48. Other factory or field installed optional circuit breakers may be used, such as CB10. S48 and CB10 are toggle or twist-style switches, which can be used by the service technician to disconnect power to the unit.

2-Transformer T1 (all units)

All units use a single line voltage to 24VAC transformer mounted in the control box. Transformer supplies power to control circuits in the unit. The transformer is rated at 70VA and is protected by a 3.5 amp circuit breaker (CB8). The 208/230 (Y) voltage transformers use two

primary voltage taps as shown in figure 3, while 460 (G) and 575 (J) voltage transformers use a single primary voltage tap.

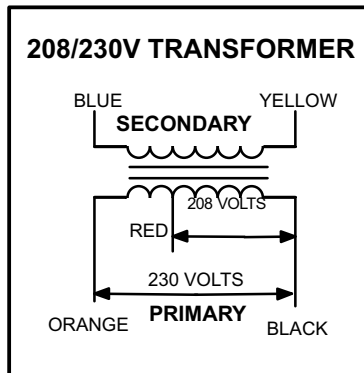

FIGURE 3

3-Transformer T18

T18 is a single line voltage to 24VAC transformer used in all units. Transformer T18 is protected by a 3.5 amp circuit breaker (CB18). T18 is identical to transformer T1. The transformer supplies 24VAC power to the contactors.

4-C. A. B. Transformers T3 & T13 (575V)

All LGH 575 (J) voltage units use transformer T3 and T13. The auto voltage to 230VAC transformers are located in the control box. The transformers have an output rating of 0.75A. T3 transformer supplies 230VAC power to combustion air blower motor (B6) while T13 transformer supplies power to combustion air blower motor (B15) in all units. T3 and T13 also provide 230VAC to optional ultraviolet germicidal (UVC) lamps.

5-Terminal Block TB13

TB13 terminal block distributes line voltage power to the line voltage items in the unit.

6-Terminal Block TB2

When unit is not equipped with an optional S48 disconnect switch, supply power is connected to TB2.

7-Outdoor Fan Motor Fuse Block & Fuses F10 and Power Exhaust Fan Motor Fuse Block and Fuses F6 (240 & 300 Y Volt Only)

Three line voltage fuses, F10, provide overcurrent protection to all condenser fans. Two line voltage fuses, F6, provide overcurrent protection to the two optional power exhaust fans. The fuses are rated at 30A in 208/230V units.

8-Fuses F4

Fuse F4 is used only with single point power supply. F4 provides overcurrent protection to the compressor and other cooling components.

Note - F4, S48 and TB2 are located inside a sheet metal enclosure in the unit front left corner mullion.

9-Outdoor Fan Capacitors C1, C2, C18, C19, C20, C21

Fan capacitors C1, C2, C18, C19, C20 and C21 are 370V / 10 MFD capacitors used to assist in the start up of condenser fans B4, B5, B21, B22, B23 and B24. respectively.

10-Compressor Contactors K1, K2, K14, K146

All compressor contactors are three pole double break contactors with a 24VAC coil. In all units, K1, K2, K14 and K146 energize compressors B1, B2, B13, and B20 respectively.

11-Blower Contactor K3

Blower contactor K3, is a three-pole-double-break contactor with a 24VAC coil used to energize the indoor blower motor B3 in response to blower demand.

12-Outdoor Fan Relay K10, K68, K149, K150, K152, K153

Outdoor fan relays K10, K68, K149, K150, K152 and K153 used in all units, are DPDT relays with a 24VAC coil. In all units, K10 energizes fan 1 (B4), K68 energizes fan 2 (B5), K149 energizes fan 3 (B21), K150 energizes fan 4 (B22), K152 energizes fan 5 (B23) and K153 energizes fan 6 (B24).

13-Combustion Air Inducer Relay K13 (LGH units - first burner section)

Combustion air inducer relay K13, used in all LGH units, is a DPDT relay with a 24VAC coil. K13 is energized by the Unit Controller A55 after a first stage heating demand from the thermostat. K13 remains energized throughout the heating demand. When energized, K13 N.O. contacts close to energize combustion air blower and begin a heating sequence. Prove switch S18, located in the compressor compartment, closes as combustion air static pressure falls to "prove" combustion air inducer operation. When S18 closes, the ignition controls and gas valves are energized to begin a heating sequence.

14-Combustion Air Inducer Relay K19 (LGH units - second burner section)

Combustion air inducer relay K19, used in all LGH units, is a DPDT relay with a 24 VAC coil. K19 is energized by A178 Unit Controller after a first stage heating demand from the thermostat. K19 remains energized throughout the first stage heating demand. When energized, K19 N.O. contacts close to energize the second heat section combustion air blower and begin second section heating sequence. Prove switch S45, located in the compressor compartment, closes as combustion air static pressure falls to "prove" combustion air blower operation. When S45 closes, the second section of the ignition control and gas valve are energized to begin the second section heating sequence.

15-Burner Controls A3 & A12 (LGH units)

All LGH units have two burner controls. A3 controls gas heat section one, while A12 controls gas heat section two. The first gas heat section and the second gas heat section burner controls are identical. Both burner controls are factory set and are not adjustable. The control makes three attempts at ignition and then locks out the system if ignition is not obtained after the third trial. Reset after lockout requires only breaking and remaking thermostat demand. The control shuts off gas flow immediately in the event of a gas or power failure. Upon restoration of gas and power,

the control will restart the ignition sequence and continue until flame is established or system locks out. For a more detailed description see the Gas Heat Components section.

16-Power Exhaust Relay K65 (PEF units)

Power exhaust relay K65 is a N.O. DPDT relay with a 24VAC coil. K65 is used in all units equipped with optional power exhaust fans. K65 is energized by the Unit Controller (A55).

17-Blower Motor Overload Relay S42

The blower motor overload relay is used in all units equipped with M-volt unit blower motors manufactured before Dec. 19, 2010 as well as units with standard efficiency motors of 10 HP. The relay (S42) is connected in line with the blower motor to monitor the current flow to the motor. When the relay senses an overload condition, a set of normally closed contacts open to de-energize pin #4 in plug P299 of the A55 Unit Controller. A55 de-energizes all outputs. Units will be equipped with a relay manufactured by Telemecanique figure 4 or Siemens figure 5.

18-Ultraviolet Germicidal Lamp (UVC) Transformer T49

UVC transformer T49 is used by units of all voltages except 208/230V LGH/LCH and 575V LGH which are equipped with a UVC. The auto voltage to 230VAC transformer is installed in the control box. The transformer has an output rating of 0.75 amps. T49 transformer supplies 230VAC power to the UVC lamp.

ELECTRIC HEAT CONTROL SECTION (30 - 120 kW electric heat only)

19-Electric Heat Relay K9

All unit equipped with optional electric heat use an electric heat relay K9. K9 is a N.O. SPST pilot relay intended to electrically interlock operation of left and right side electric heat sections. K9 is energized by the A55 Unit Controller.

20-Unit Controller A55 (all units)

The Unit Controller provides all unit control functions, unit status information, unit diagnostics, programmable parameters and USB verification and profile sharing. Refer to the Unit Controller guide provided with the unit. Thermostat wires are connected to J297 on the Unit Controller.

21-Compressor 3 & 4 Control Module A178 (all units)

The compressor 3 & 4 control module A178 controls two additional compressor stages. A178 includes all inputs and outputs required for compressor and fan control, compressor stage diagnostics, and low ambient control.

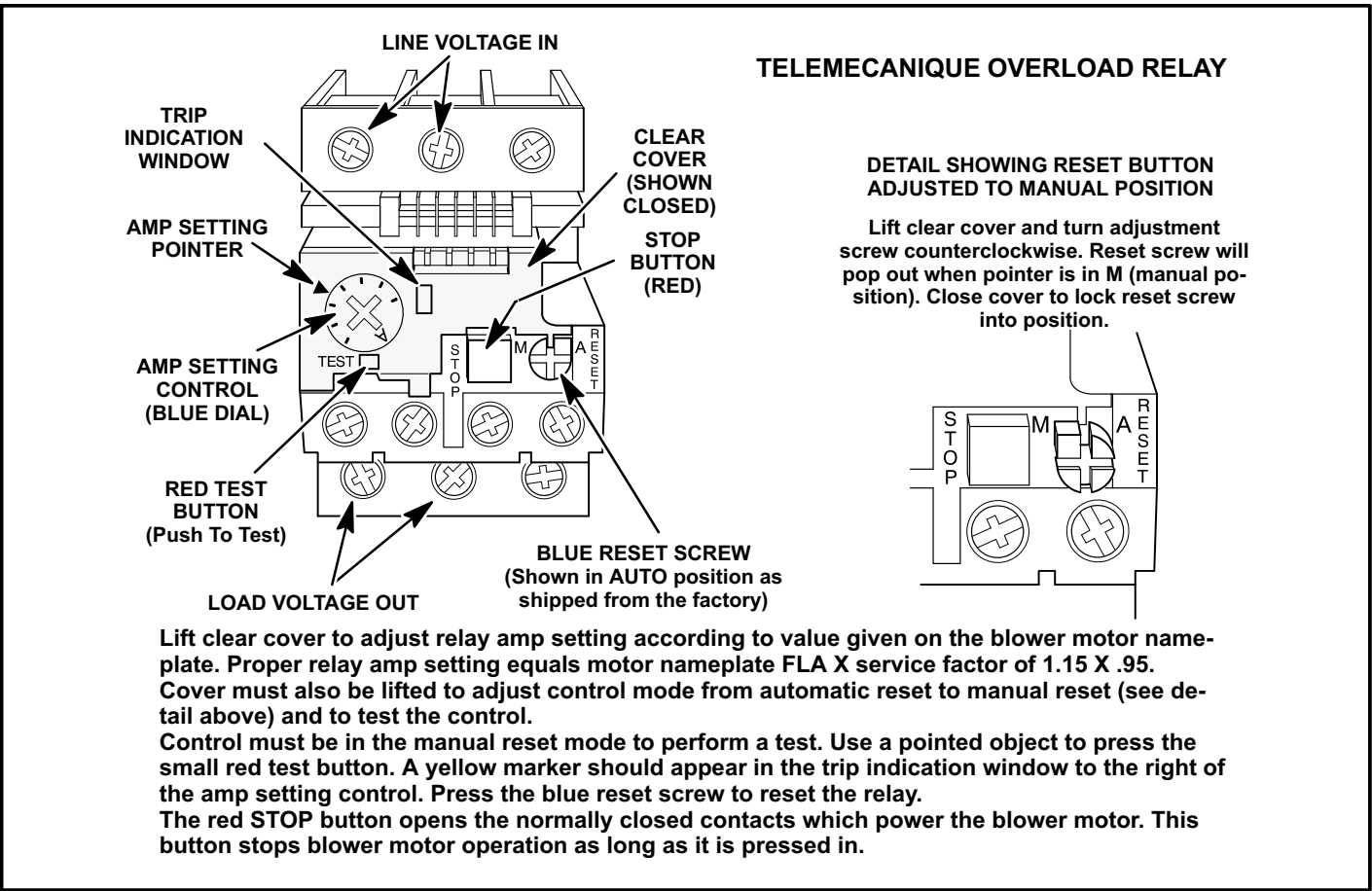

FIGURE 4

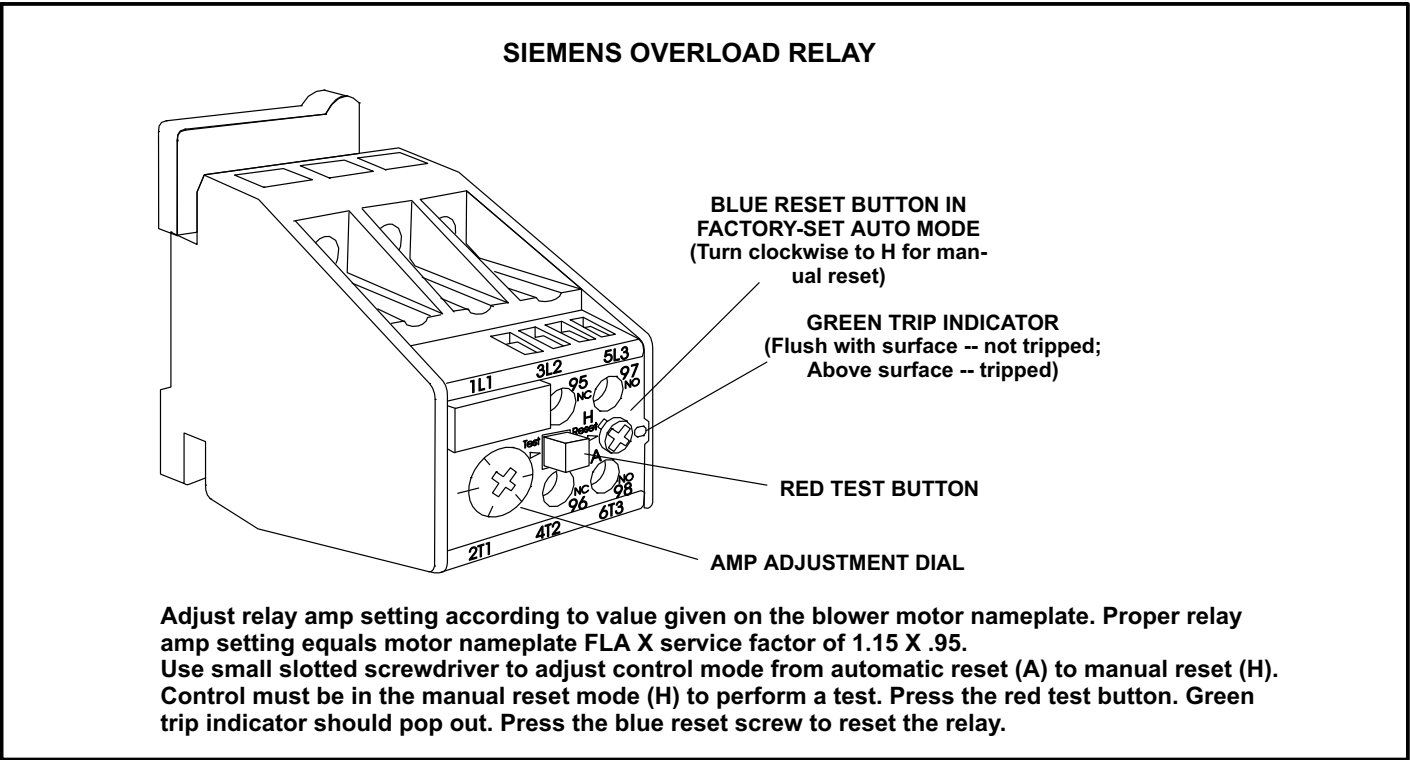

FIGURE 5

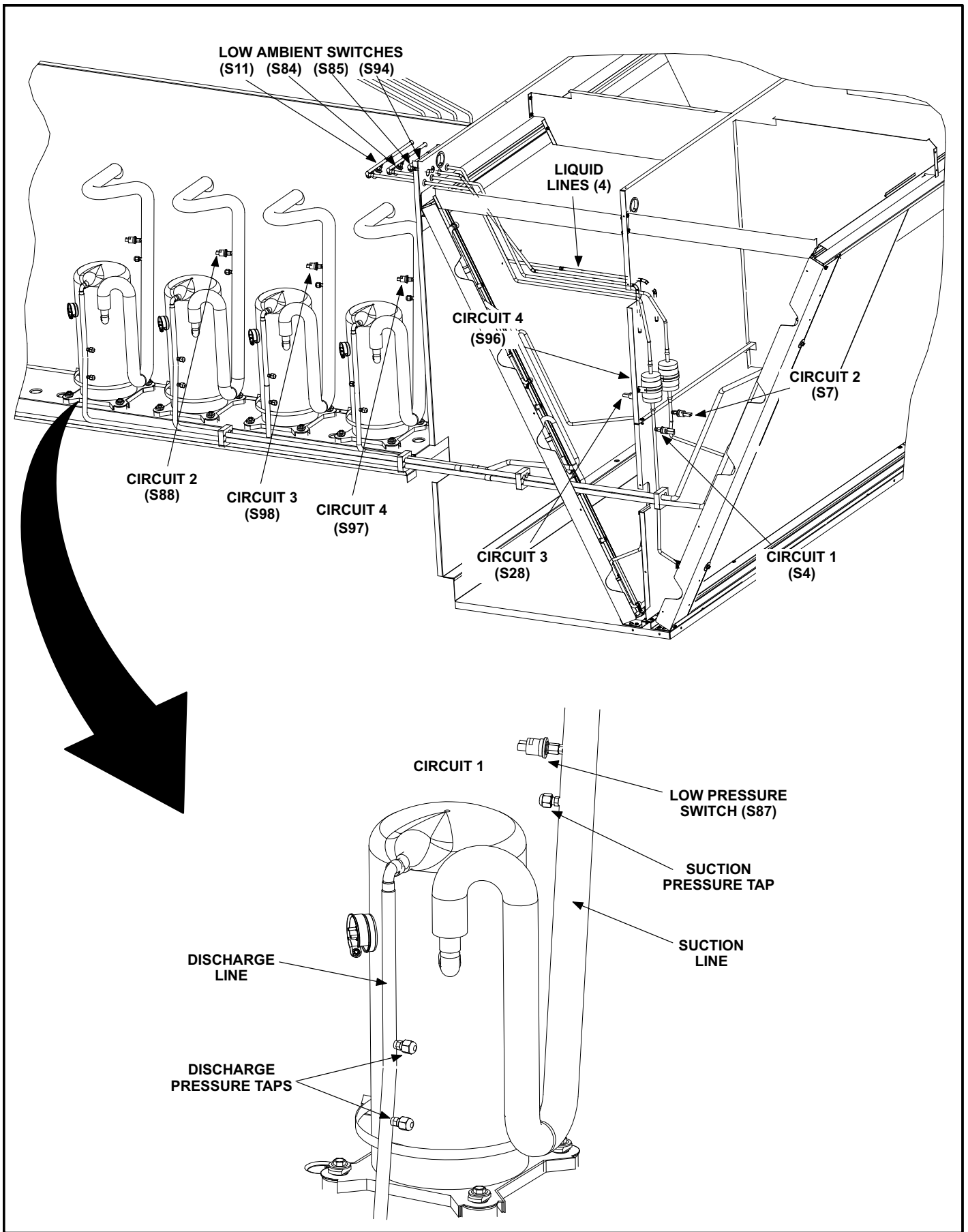

FIGURE 6

B-Cooling Components Figure 6

All units use independent cooling circuits (figure 8) consisting of separate compressors, condenser coils and evaporator coils. Six draw-through type condenser fans are used in all units. All units are equipped with belt-drive blowers which draw air across the evaporator during unit operation.

Cooling may be supplemented by a factory- or field-installed economizer. The evaporators are slab type and are stacked. Each evaporator uses a thermostatic expansion valve as the primary expansion device. Each evaporator is also equipped with enhanced fins and rifled tubing. In all units each compressor is protected by a crankcase heater, high pressure switch and low pressure switch. Additional protection is provided by low ambient switches and freezestats (on each evaporator).

1-Compressors B1, B2, B13, B20

WARNING

Electrical shock hazard. Compressor must be grounded. Do not operate without protective cover over terminals. Disconnect power before removing protective cover. Discharge capacitors before servicing unit. Failure to follow these precautions could cause electrical shock resulting in injury or death.

All units use four scroll compressors. See figure 6. Compressor capacity may vary from stage to stage. In all cases, the capacity of each compressor is added to reach the total capacity of the unit. Compressor electrical specifications can be found in the SPECIFICATIONS section in this manual. Each compressor is energized by a corresponding compressor contactor.

NOTE-Refer to the wiring diagram section for specific unit operation.

If Interlink compressor replacement is necessary, call 1-800-4-LENNOX (1-800-453-6669).

IMPORTANT

Some scroll compressors have an internal vacuum protector that will unload scrolls when suction pressure goes below 20 psig. A hissing sound will be heard when the compressor is running unloaded. Protector will reset when low pressure in system rises above 40 psig. DO NOT REPLACE COMPRESSOR.

2-Crankcase Heaters HR1, HR2, HR5, HR11

All units use bellyband-type crankcase heaters. Heater HR1 is installed around compressor B1, heater HR2 compressor B2, HR5 compressor B13, and HR11 compressor B20. Crankcase heater wattage varies by compressor size.

IMPORTANT

Pressure switch settings are significant higher on R410A charged units than R22 charged units.

3-High Pressure Switches S4, S7, S28, S96

The high pressure switch is an auto-reset SPST N.C. switch which opens on a pressure rise. All units are equipped with this switch. The switch is located in the liquid line and is wired in series with the compressor contactor coil through A55 Unit Controller or A178 Compressor 3 and 4 Controller.

S4 (first circuit), S7 (second circuit), S28 (third circuit), and S96 (fourth circuit) are wired in series with the respective compressor contactor coils.

When liquid pressure rises to 610 ± 15 psig (4206 ± 103 kPa) (indicating a problem in the system) the switch opens and the respective compressor is de-energized (the economizer can continue to operate). When liquid pressure drops to 475 ± 15 psig (3275 ± 103 kPa) the pressure switch will close.

Unit Controller A55 has a three-strike counter before locking out the particular compressor circuit. This means the control allows three high pressure trips per one thermostat demand. The control can be reset by breaking and remaking the thermostat demand or manually resetting the control.

4-Low Ambient Switches S11, S84, S85, S94

The low ambient switch is an auto-reset SPST N.O. pressure switch which allows for mechanical cooling operation at low outdoor temperatures. All units are equipped with this switch. In all models a switch is located in each liquid line prior to the indoor coil section.

In all units, S11 (compressor one) and S84 (compressor 2) are wired in parallel to the A55 Unit Controller. S85 (compressor 3) and S94 (compressor four) are wired in parallel to the Unit Controller. A178 Compressor 3 & 4 Controller will cycle outdoor fan 3 (B21) via K149. A178 Compressor 3 & 4 controller will also cycle outdoor fan 4 (B22) via K150.

Units charged with R410A

When liquid pressure rises to 450 ± 10 psig (3102 ± 69 kPa), the switch closes and the Unit Controller will energized condenser fan associated with that refrigerant circuit. When liquid pressure drops to 240 ± 10 psig (1655 ± 69 kPa), the switch opens and the Unit Controller will de-energized condenser fan associated with that refrigerant circuit. This intermittent fan operation results in higher evaporating temperature allowing the system to operate without icing the evaporator coil and losing capacity.

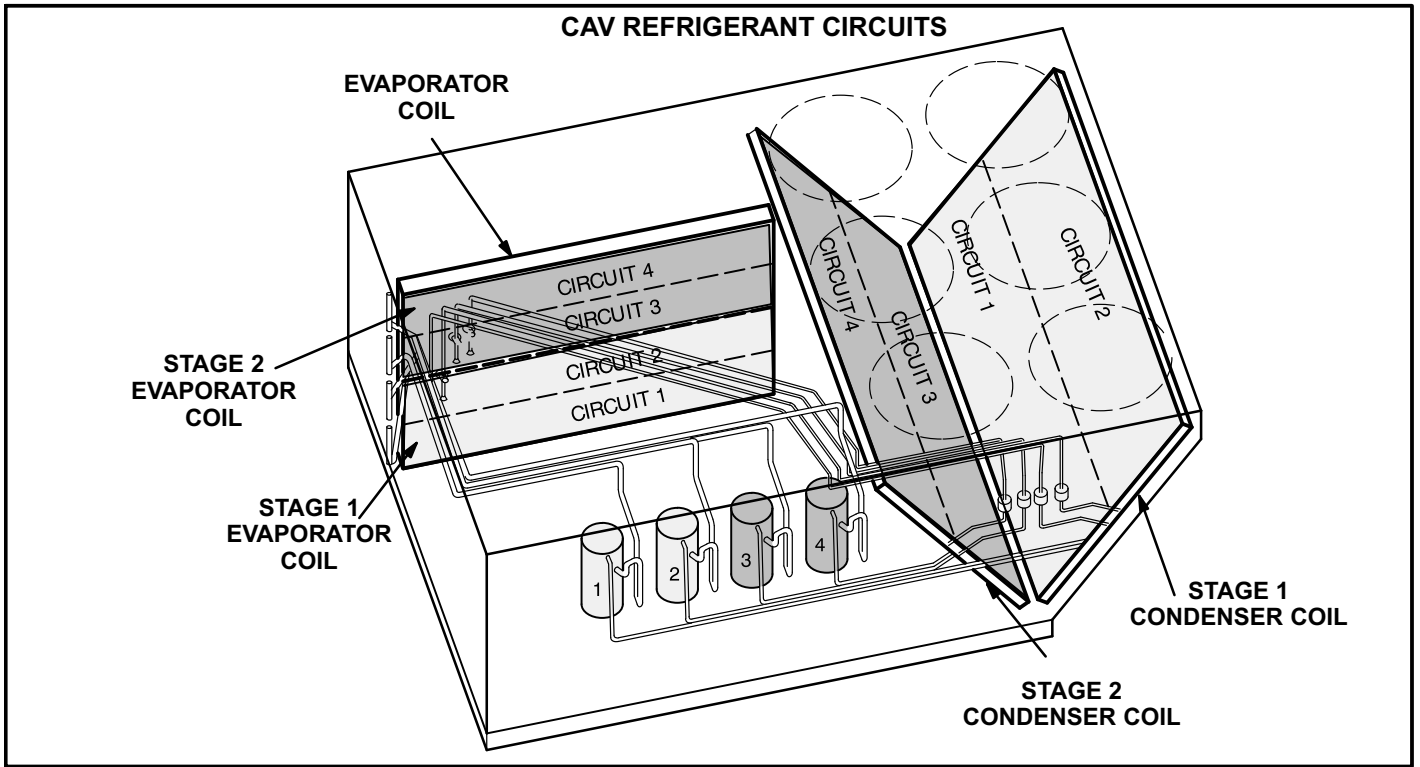

FIGURE 7

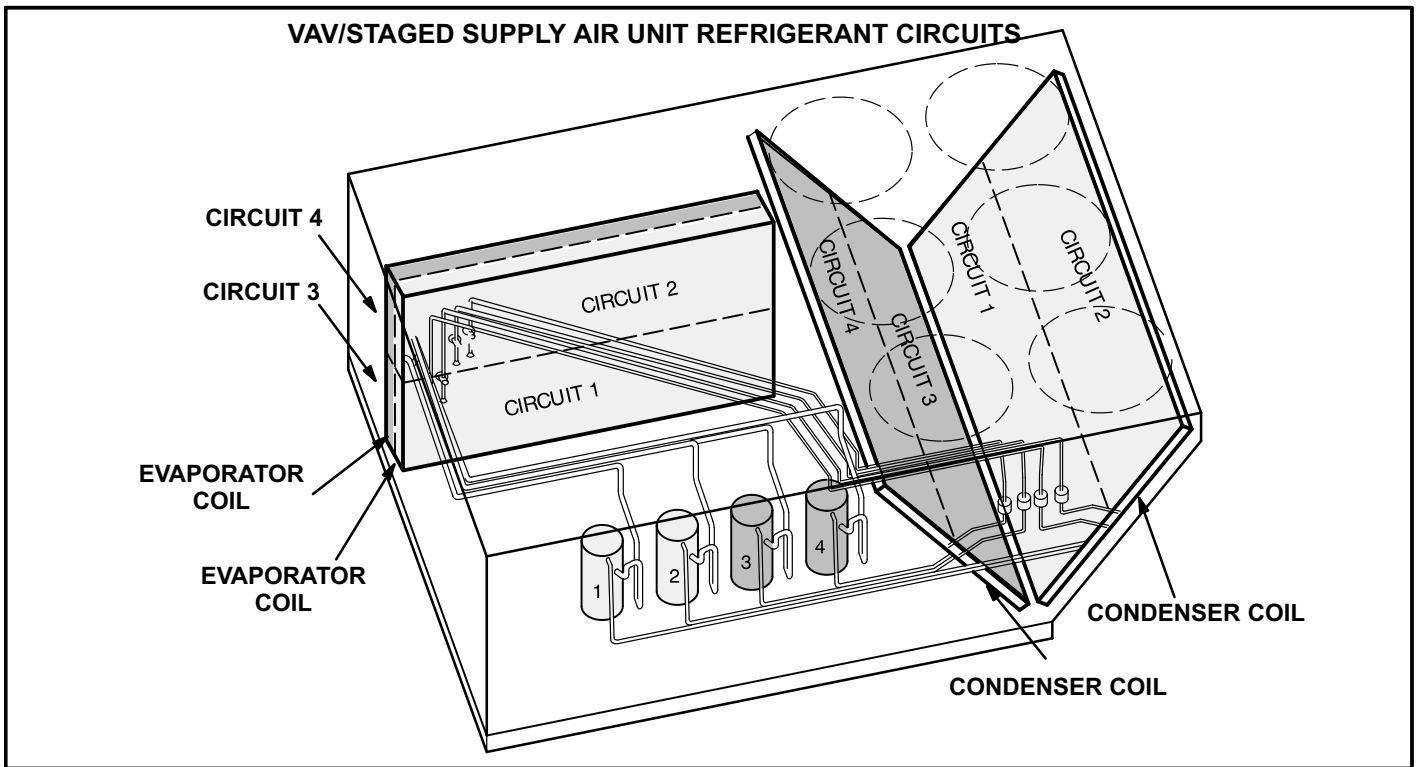

FIGURE 8

5-Low Pressure Switches S87, S88, S98, S97

The low pressure switch is an auto-reset SPST N.O. switch (held N.C. by refrigerant pressure) which opens on a pressure drop. All units are equipped with this switch. The switch is located in the compressor suction line.

S87 (compressor one), S88 (compressor two), S98 (compressor three), and S97 (compressor four) are wired in series with the contactor coils through the A55 Unit Controller.

The Unit Controller A55 governs the low pressure switches by shunting the switches during start up until pressure is stabilized. After the shunt period, the control has a three-strike counter, during first thermostat demand, before the compressor is locked out. The control is reset by breaking and remaking the thermostat demand or manually resetting the control.

When suction pressure drops to 40 ± 5 psig (276 ± 34 kPa) (indicating low pressure), the switch opens and the compressor is de-energized. The switch automatically resets when pressure in the suction line rises to 90 ± 5 psig (620 ± 34 kPa), due to many causes such as refrigerant being added.

6-Filter Drier (all units)

All units have a filter drier located in the liquid line of each refrigerant circuit at the exit of each condenser coil. The drier removes contaminants and moisture from the system.

7-Freezestats S49, S50, S53, S95

Each unit is equipped with a low temperature switch (freezestat) located on the return bend of each evaporator coil. S49 (first circuit), S50 (second circuit), S53 (third circuit), and S95 (fourth circuit) are located on the corresponding evaporator coils.

Each freezestat is wired in series with the compressor contactor coil through the unit control box to the A55 Unit Controller. Each freezestat is a SPST N.C. auto-reset switch which opens at $29^{\circ}\text{F} \pm 3^{\circ}\text{F}$ ($-1.7^{\circ}\text{C} \pm 1.7^{\circ}\text{C}$) on a temperature drop and closes at $58^{\circ}\text{F} \pm 4^{\circ}\text{F}$ ($14.4^{\circ}\text{C} \pm 2.2^{\circ}\text{C}$) on a temperature rise. To prevent coil icing, freezestats open during compressor operation to temporarily disable the respective compressor until the coil warms sufficiently to melt any accumulated frost.

If the freezestats are tripping frequently due to coil icing, check the unit charge, airflow and filters before allowing unit back in operation. Make sure to eliminate conditions which might promote evaporator ice buildup.

8-Condenser Fans B4, B5, B21, B22, B23, B24

See Specifications section in this manual for specifications of condenser fans. All condenser fans used have single-phase motors. All units are equipped with six condenser fans. The complete fan assembly may be removed for servicing and cleaning by removing the fan grill and turning the complete assembly until the motor brackets line up with the notches in the top panel. Lift the fan assembly out of the unit and disconnect the jack plug located on the motor.

C-Blower Compartment

The blower compartment in all units is located between the evaporator coil and the compressor / control section on the opposite side of the condenser coil. The blower assembly is accessed by disconnecting the blower motor wiring (and all other plugs) and removing the screws on either side of the sliding base. The base pulls out as shown in figure 9.

1-Blower Wheels (all units)

All units have two 18 in. x 15 in. (457 mm x 381 mm) blower wheels. Both wheels are driven by one motor.

2-Indoor Blower Motor B3 (all units)

All units use three-phase single-speed blower motors. CFM adjustments are made by adjusting the motor pulley (sheave). Motors are equipped with sealed ball bearings. All motor specifications are listed in the SPECIFICATIONS section in this manual. Units may be equipped with motors manufactured by various manufacturers, therefore electrical FLA and LRA specifications will vary. See unit rating plate for information specific to your unit.

⚠ IMPORTANT

Three phase scroll compressors must be phased sequentially for correct compressor and blower rotation. Follow "COOLING START-UP" section of installation instructions to ensure proper compressor and blower operation.

A-Blower Operation

NOTE-The following is a generalized procedure and does not apply to all thermostat control systems.

- 1- Blower operation is dependent on the thermostat control system option that has been installed in the units. Refer to operation sequence of the control system installed for detailed descriptions of blower operation.

- 2- Generally, blower operation is set at the thermostat fan switch. With the fan switch in "ON" position and the **OCP** input is "**ON**", the blower operates continuously. With the fan switch in "AUTO" position, the blower cycles with demand.
- 3- In most cases, the blower and entire unit will be off when the system switch is in the "OFF" position. The only exception is immediately after a heating demand when the blower control keeps the blower on until all heat is extracted from the heat exchanger.

B-Blower Access

- 1- Disconnect wiring connected to heating limit switches and mixed air sensor in units with an economizer. Disconnect blower harness at K3 contactor (CAV) or A96 inverter (VAV/Staged). Failure to do so could damage harness or components.
- 2- Remove screws on either side of blower assembly sliding base. See figure 9.
- 3- Pull base toward outside of unit.

C-Determining Unit CFM

- 1- The following measurements must be made with a dry indoor coil. Run blower without a cooling demand. Measure the indoor blower shaft RPM. Air filters must be in place when measurements are taken.
- 2- With all access panels in place, measure static pressure external to unit (from supply to return). Blower performance data is based on static pressure readings taken in locations shown in figure 10.

Note - Static pressure readings can vary if not taken where shown.

- 3- Referring to blower tables in the front of this manual, use static pressure and RPM readings to determine unit CFM. Use table "FACTORY INSTALLED OPTIONS/FIELD INSTALLED ACCESSORY AIR RESISTANCE" when installing units with any of the optional accessories listed.

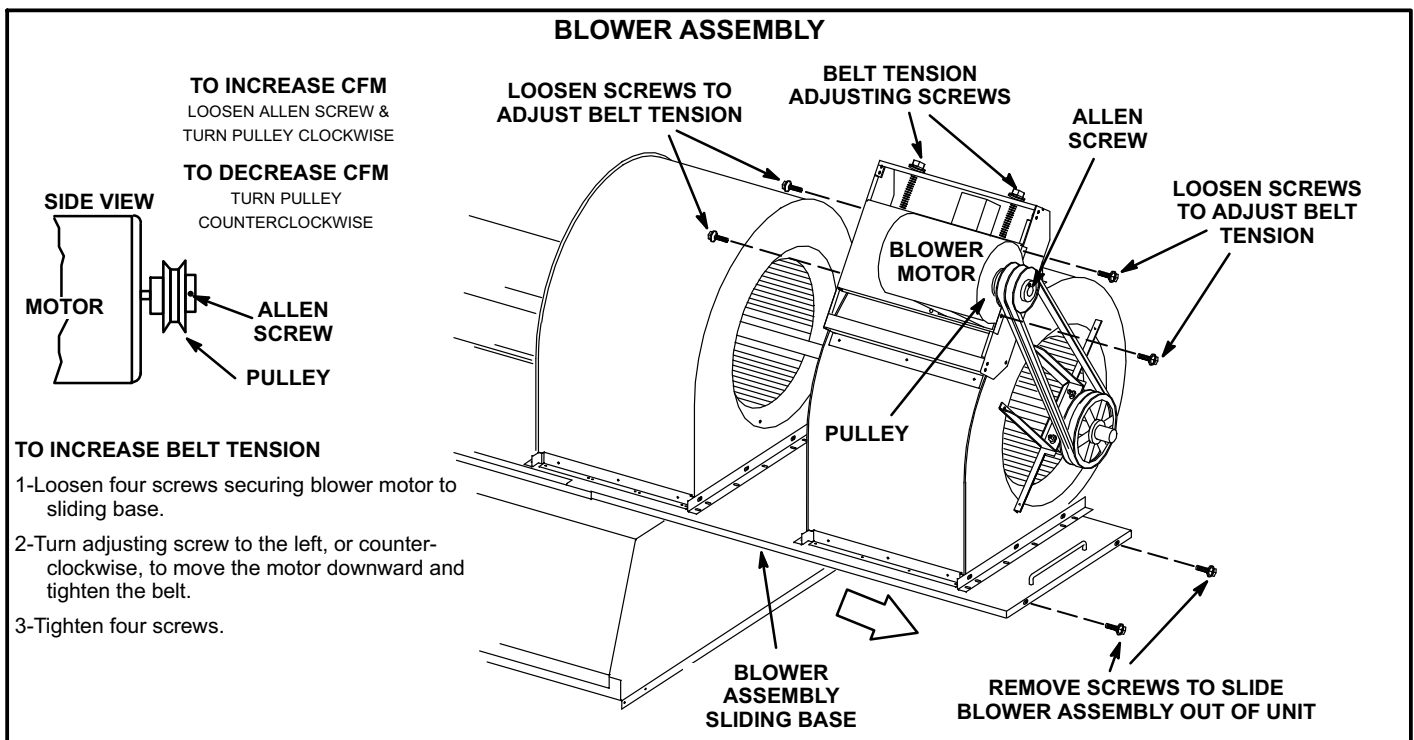

FIGURE 9

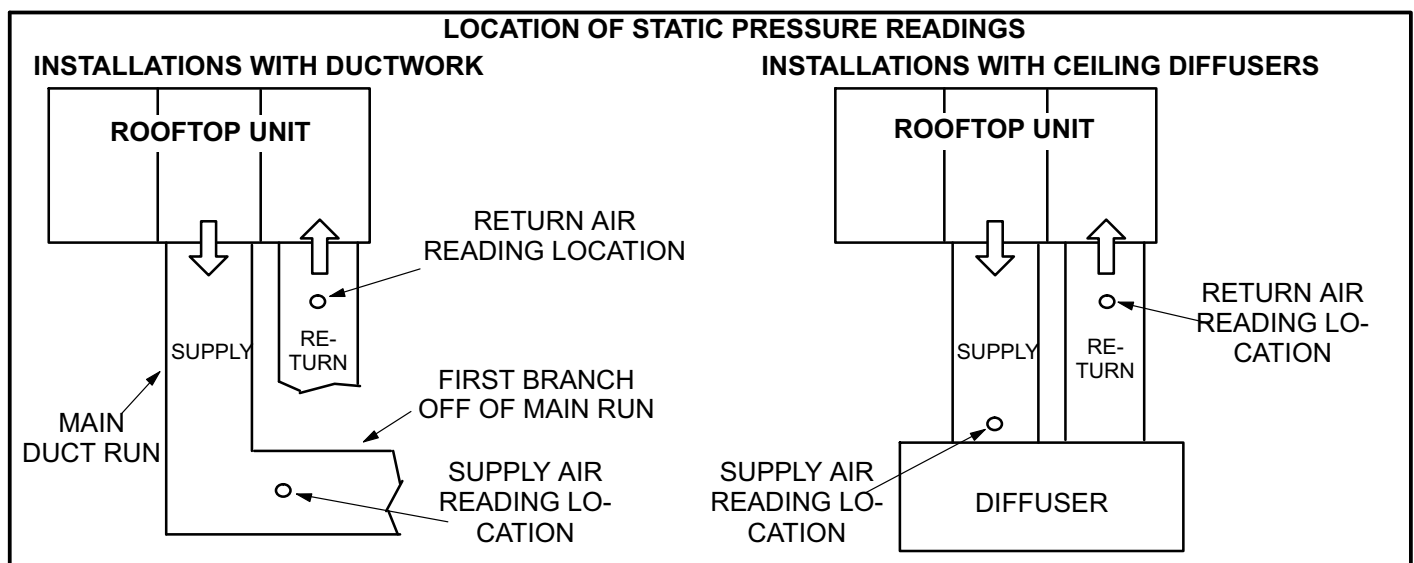

FIGURE 10

**TABLE 1
 MINIMUM AND MAXIMUM PULLEY ADJUSTMENT**

| Belt | Minimum Turns Open | Maximum Turns Open |
|-----------|--------------------|--------------------|
| A Section | No minimum | 5 |
| B Section | 1* | 6 |

*No minimum number of turns open when B belt is used on pulleys 6" O.D. or larger.

4- *Constant Air Volume (CAV) Supply Air Blowers* - The blower RPM can be adjusted at the motor pulley. Loosen Allen screw and turn adjustable pulley clockwise to increase CFM. Turn counterclockwise to decrease CFM. See figure 9. Do not exceed minimum and maximum number of pulley turns as shown in table 1.

5- *Variable Air Volume (VAV) Supply Air Blowers* - Adjust motor pulley to set-up maximum blower RPM and CFM at 60 HZ. Do not exceed brake horse power of the motor. Loosen Allen screw and turn adjustable pulley clockwise to increase CFM. Turn counterclockwise to decrease CFM. See figure 9. Do not exceed minimum and maximum number of pulley turns as shown in table 1.

After setting up the maximum CFM at 60HZ, the supply CFM can be adjusted at the Unit Controller or by using optional software. This value is adjusted through unit Parameter 390.

In default mode, the Unit Controller is set to drive the blower to maximum CFM output (100% or 60Hz). To

decrease the CFM, reduce the VAV maximum output. This output is adjusted through unit parameter 390.

For default blower maximum and minimum CFM output, refer to unit labels. To adjust the minimum blower output and the VAV minimum output refer to parameters 27 and 28.

D-Blower Belt Adjustment

Maximum life and wear can be obtained from belts only if proper pulley alignment and belt tension are maintained. Tension new belts after a 24-48 hour period of operation. This will allow belt to stretch and seat grooves. Make sure blower and motor pulley are aligned as shown in figure 11 for standard blowers and figure 12 for blowers equipped with an optional belt tensioner.

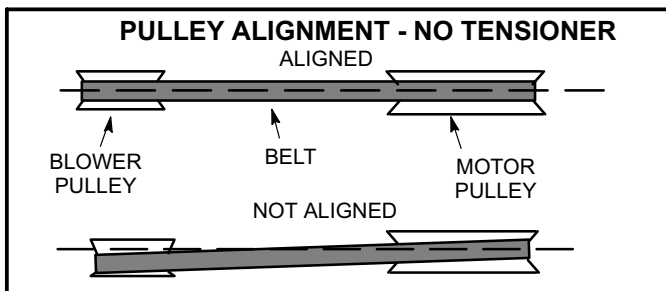

FIGURE 11

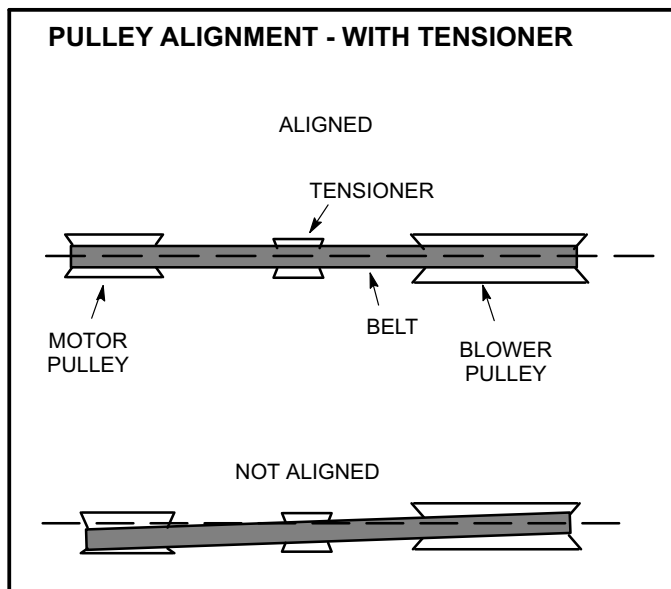

FIGURE 12

Standard Blowers

- 1- Loosen four screws securing blower motor to sliding base. See figure 9.
- 2- *To increase belt tension -*
Turn belt tension adjusting screw to the left, or counterclockwise, to tighten the belt. This increases the distance between the blower motor and the blower housing.

To loosen belt tension -

Turn the adjusting screw to the right, or clockwise to loosen belt tension.

- 3- Tighten four screws securing blower motor to sliding base once adjustments have been made.

Blowers Equipped With Belt Tensioner

- 1- Loosen the bolt in the center of the tensioner. See figure 13.
- 2- Place belt over all three pulleys as shown in blower assembly figure 13. Tensioner pulley must be oriented toward blower, not motor.
- 3- Using a 15/16" wrench on the tensioner body nut, turn the tensioner nut until marks align as shown in figure 13 (3rd mark).
- 4- Hold the tensioner with marks aligned and tighten the bolt to 22 ft.lbs. using the 9/16" wrench.
- 5- If tensioner pulley is past 7 o'clock when secured, turn belt tension adjusting screw to the left, or counterclockwise, to tighten the belt. This increases the distance between the blower motor and the blower housing.

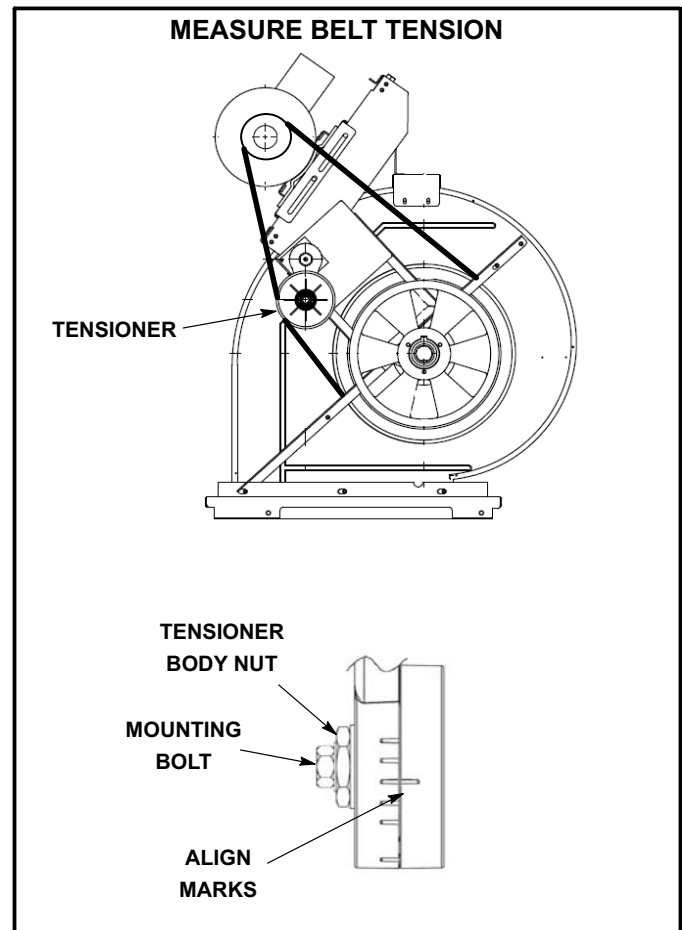

FIGURE 13

E-Check Belt Tension

Overtensioning belts shortens belt and bearing life. Check belt tension as follows:

- 1- Measure span length X. See figure 14.

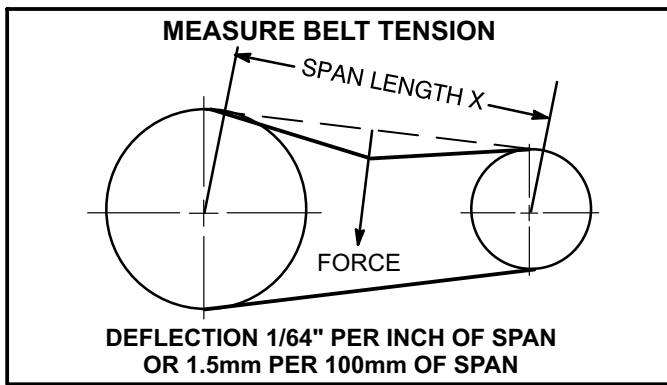

FIGURE 14

- 2- Apply perpendicular force to center of span (X) with enough pressure to deflect belt 1/64" for every inch of span length or 1.5mm per 100mm of span length.

Example: Deflection distance of a 40" span would be 40/64" or 5/8".

Example: Deflection distance of a 400mm span would be 6mm.

- 3- Measure belt deflection force. For a used belt, the deflection force should be 5 lbs. (35kPa). A new belt deflection force should be 7 lbs. (48kPa). A force below these values indicates an undertensioned belt. A force above these values indicates an overtensioned belt.

F-Furnished Blower Drives

For field furnished blower drives, see BLOWER DATA (table of contents) for CFM and RPM. The BLOWER DATA section also has tables for drive numbers and manufacturer's model numbers. Reference the manufacturer's model numbers in table 2.

**TABLE 2
MANUFACTURER'S NUMBERS (60 HZ)**

| Drive No. | DRIVE COMPONENTS | | | | | | | | | |
|-----------|-------------------|--------------|--------------|--------------|--------------|--------------|--------------------|--------------|---------------|--------------|
| | ADJUSTABLE SHEAVE | | FIXED SHEAVE | | BELTS | | BELTS W/ TENSIONER | | SPLIT BUSHING | |
| | Supplier No. | OEM Part No. | Supplier No. | OEM Part No. | Supplier No. | OEM Part No. | Supplier No. | OEM Part No. | Supplier No. | OEM Part No. |
| 1 | 1VP71x1-3/8 | 100239-06 | BK140H | 100788-13 | BX78 | 100245-44 | BX77 | 100245-43 | H - 1-7/16 | 49M6201 |
| 2 | 1VP71x1-1/8 | 100239-06 | BK120H | 100788-07 | BX75 | 31K9801 | BX73 | 100245-41 | H - 1-7/16 | 49M6201 |
| 3 | 1VP65x1-3/8 | 78M7101 | BK130H | 100788-08 | BX75 | 31K9801 | BX74 | 100245-42 | H - 1-7/16 | 49M6201 |
| 4 | 1VP60x1-3/8 | 78L5501 | BK110H | 100788-06 | BX71 | 31K9701 | BX71 | 31K9701 | H - 1-7/16 | 49M6201 |
| 5 | 1VP56x1-1/8 | P-8-1492 | BK120H | 100788-07 | BX71 | 31K9701 | BX71 | 31K9701 | H - 1-7/16 | 49M6201 |
| 6 | 1VP60x1-1/8 | 41C1301 | BK110H | 100788-06 | BX70 | 31K9601 | BX70 | 31K9601 | H - 1-7/16 | 49M6201 |
| 7 | 1VP50x1-1/8 | P-8-1977 | BK120H | 100788-07 | BX70 | 31K9601 | BX70 | 31K9601 | H - 1-7/16 | 49M6201 |
| 8 | 1VP44x1-1/8 | 36C0701 | BK120H | 100788-07 | BX70 | 31K9601 | BX70 | 31K9601 | H - 1-7/16 | 49M6201 |
| 9 | 1VP44x1-1/8 | 36C0701 | BK140H | 100788-13 | BX73 | 100245-41 | BX72 | 100245-14 | H - 1-7/16 | 49M6201 |

D-GAS HEAT COMPONENTS (LGH Units)

Units are available in 260,000 Btuh (76.2 kW) standard gas heat, 360,000 Btuh (105.5 kW) medium gas heat and 480,000 Btuh (140.6 kW) high gas heat sizes. See unit nameplate for capacities. All units are equipped with two identical gas heat sections (gas heat section one and gas heat section two). Flexible pipe will feed supply gas to both sections. If for service the flexible connection must be broken, hand tighten, then using a wrench turn additional 1/4 turn for metal to metal seal (*do not over tighten*).

NOTE-Do not use thread sealing compound on flex pipe flare connections.

1-Control Box Components

A3, A12, A55, A178, T3, T13, K13 and K19

The main control box (see figure 2) houses the burner controls A3 and A12, Unit Controller A55 and A178, combustion air inducer transformers T3 and T13, combustion air inducer relay K13, and second heat section relay K19. For a description of the components see section I-A. A more detailed description of burner controls A3 and A12 is given below.

Burner Ignition Control A3 and A12

The ignition controls are located in the control box and are manufactured by Utec. See table 3 for LED codes.

The ignition control provides three main functions: gas valve control, ignition, and flame sensing.

On a heating demand, the ignition control checks for a closed limit switch. Once this check is complete and conditions are correct, the ignition control then allows 30 seconds for the combustion air inducer to vent exhaust gases from the burners. When the combustion air inducer is purging the exhaust gases, the combustion air prove switch closes proving that the combustion air inducer is operating before allowing the ignition control to energize. When the combustion air prove switch is closed and the delay is over, the ignition control activates the gas valve(s), the spark electrode and the flame sensing electrode. At the start of the ignition se-

quence, the adjustable 40 second (default) indoor blower delay period begins. Sparking stops immediately after flame is sensed or at the end of the 8 second trial for ignition. If flame is not sensed, A3 or A12 will wait 5 minutes before attempting ignition again. If the third trial fails, A3 or A12 will lock-out for one hour. The A55 counts this as a **first** strike. After the first lock-out hour elapses, A3 or A12 will attempt ignition three more times. If flame is still not sensed, A3 or A12 will lock-out for the second hour. A55 counts this as the **second** strike. After the second lockout hour, A3 or A12 will attempt ignition three more times. If ignition fails, A55 considers this the **third** strike and will lock-out unit operation. Service relay contacts close and alarm 59 or 69 is displayed. The unit will remain in lock-out until:

1-A55 is reset

or

2-The alarm condition is cleared **AND** the alarm status is read through the SBUS command.

Once the flame is sensed, the ignition control then proceeds to "steady state" mode where all inputs are monitored to ensure the limit switch, roll-out switch and prove switch are closed as well as flame is present. When the heat call is satisfied the gas valve and combustion air inducer are de-energized. An adjustable 120-second (default) blower off delay begins.

TABLE 3

| UTEC | |
|-------------|--|
| LED Flashes | Indicates |
| Steady Off | No power or control hardware fault. |
| Steady On | Power applied. Control OK. |
| 3 Flashes | Ignition lockout from too many trials. |
| 4 Flashes | Ignition lockout from too many flame losses within single call for heat. |
| 5 Flashes | Control hardware fault detected. |

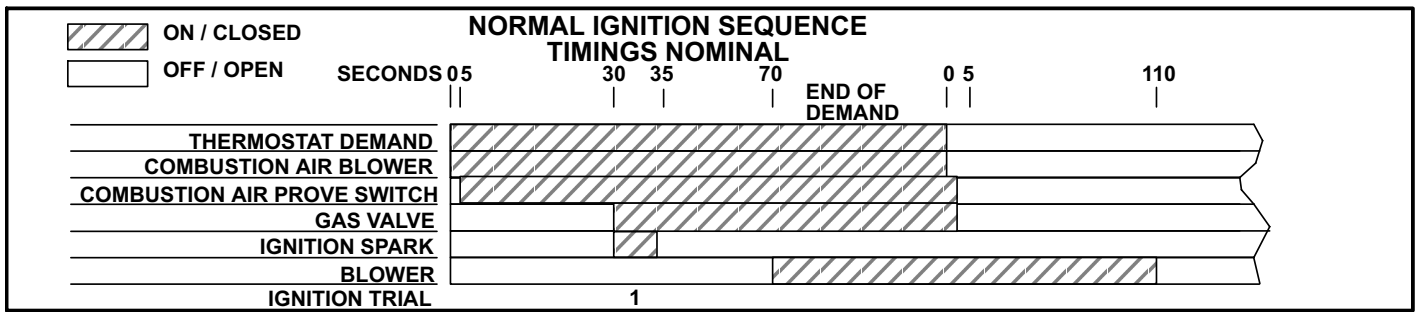

FIGURE 15

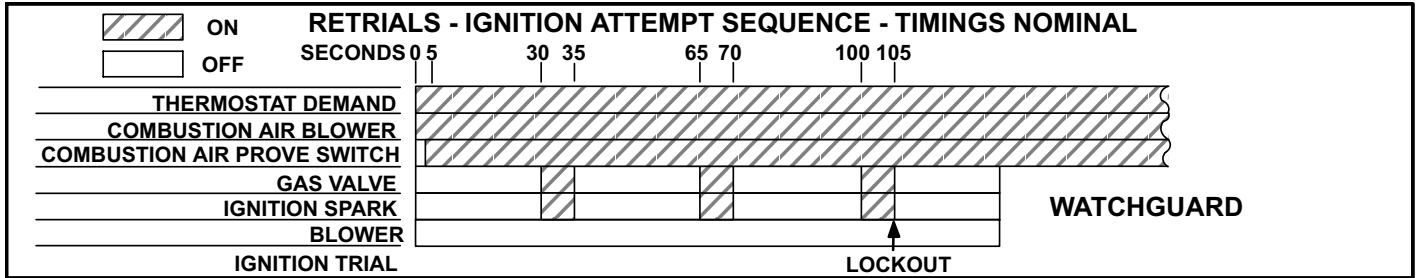

FIGURE 16

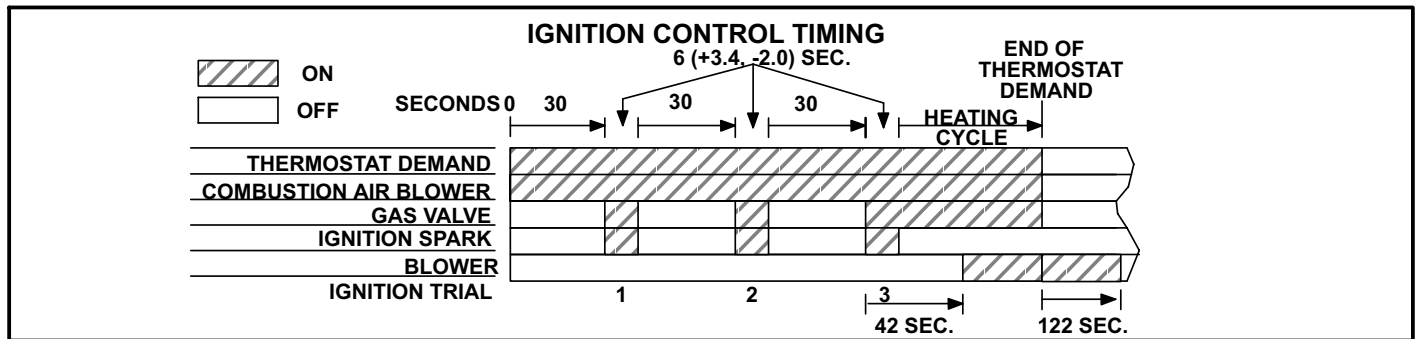

FIGURE 17

⚠ WARNING

SHOCK HAZARD. SPARK RELATED COMPONENTS CONTAIN HIGH VOLTAGE WHICH CAN CAUSE PERSONAL INJURY OR DEATH. DISCONNECT POWER BEFORE SERVICING. CONTROL IS NOT FIELD REPAIRABLE. UNSAFE OPERATION WILL RESULT. IF THE CONTROL IS INOPERABLE, SIMPLY REPLACE THE ENTIRE CONTROL.

2-Heat Exchanger (Figures 18 and 19)

Two Styles used

The LGH units use aluminized steel inshot burners with matching tubular aluminized steel (stainless steel is an option) heat exchangers and two-stage redundant gas valves. LGH uses two eleven-tube/burners for high heat, two nine-tube burners for medium heat (if applicable, see unit nameplate) and two six-tube/burners for standard heat. Each burner uses a burner venturi to mix gas and air for proper combustion. Combustion takes place at each tube entrance. As hot combustion gases are drawn upward through each tube by the combustion air blower, exhaust gases are drawn out the top and fresh air/gas mixture is drawn in at the bottom. Heat is transferred to the air stream from all surfaces of the heat exchanger tubes. The supply air blowers, controlled by the Unit Controller A55, force air across all surfaces of the tubes to extract the heat of combustion. The shape of the tubes ensures maximum heat transfer.

The gas valves accomplish staging by providing more or less gas to the burners as required by heating demand.

3-Burner Assembly (Figure 20)

The burners are controlled by the spark electrode, flame sensing electrode, gas valve and combustion air blower. The spark electrode, flame sensing electrode and gas valve are directly controlled by ignition control. Ignition control and combustion air inducer is controlled by Unit Controller A55.

Burners

All units use inshot burners (see figures 20 and 21). Burners are factory set and do not require adjustment. A peep hole with cover is furnished in the heating access panel for flame viewing. Always operate the unit with the access panel in place. Burners can be removed individually for service. Burner maintenance and service is detailed in the SERVICE CHECKS sections of this manual.

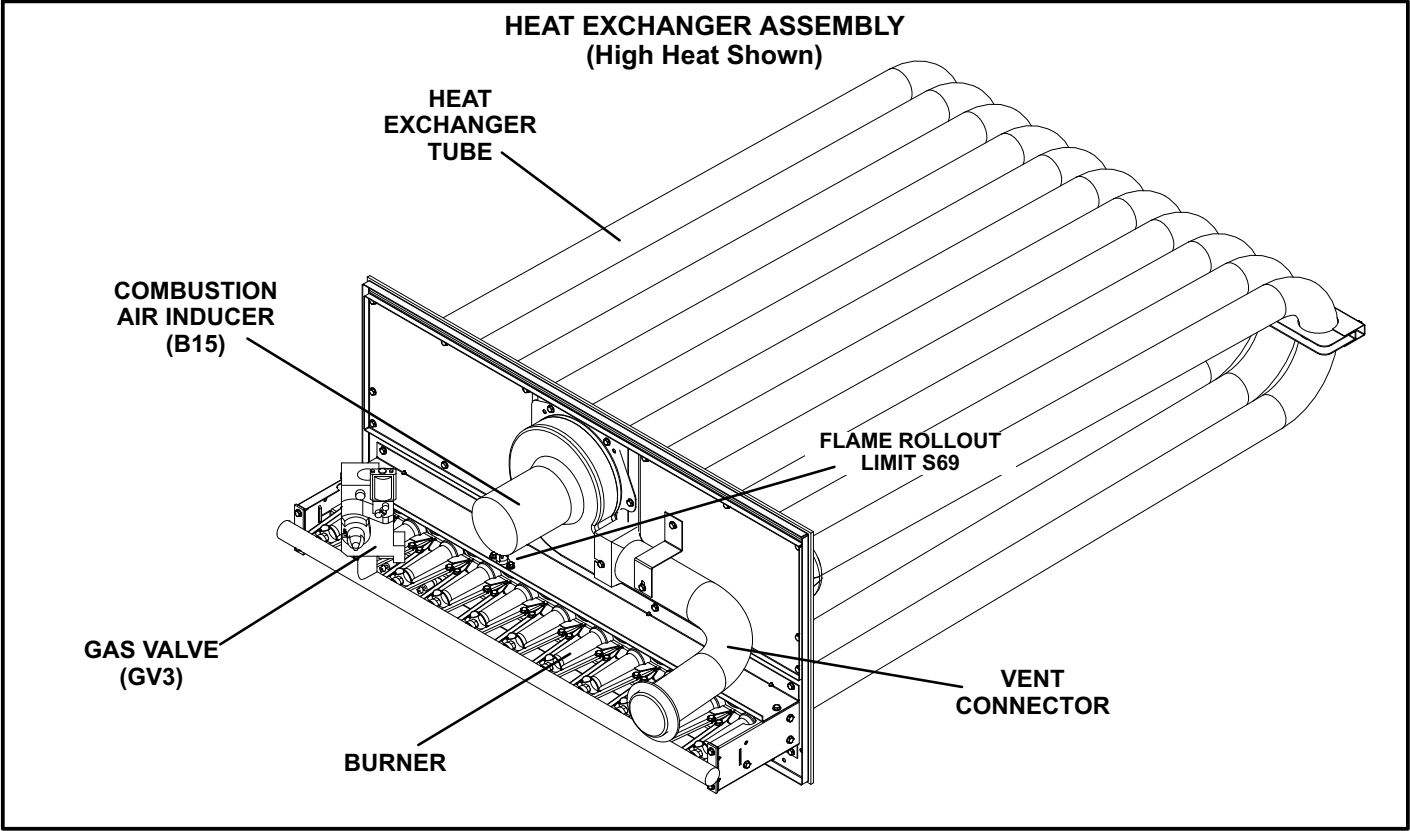

FIGURE 18

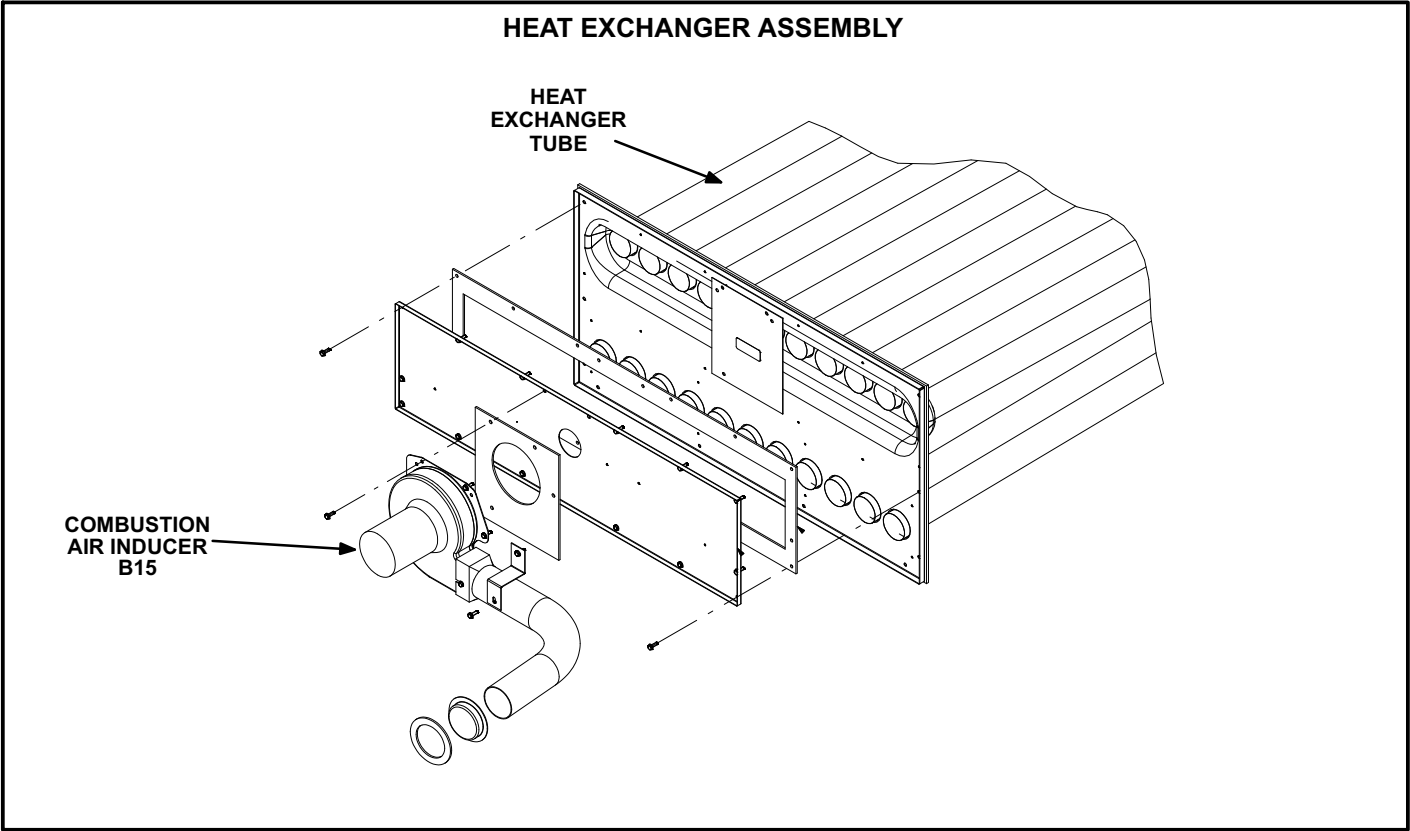

FIGURE 19

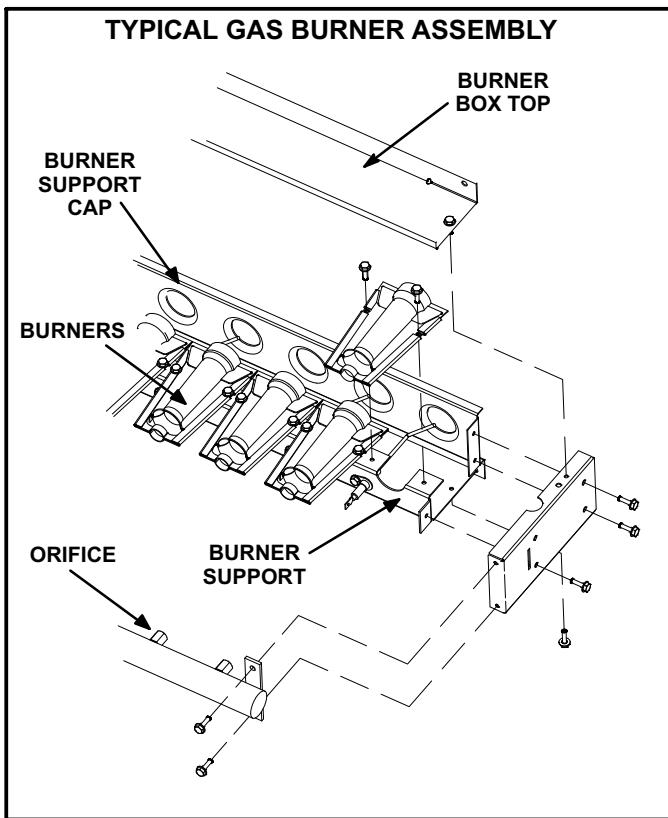

FIGURE 20

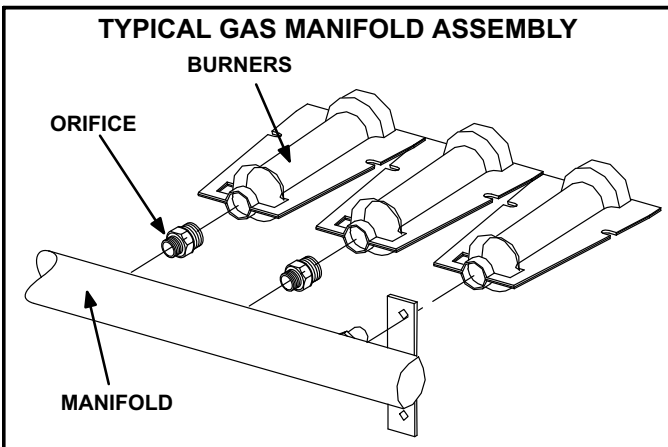

FIGURE 21

Orifice

Each burner uses an orifice which is precisely matched to the burner input. See figure 22 for the two types of orifices; install only orifices with the same threads. The orifice is threaded into the burner manifold. The burner is supported by the orifice and will easily slide off for service.

NOTE - Do not use thread sealing compound on the orifices. Using thread sealing compound may plug the orifices.

Each orifice and burner are sized specifically to the unit. Refer to Product Zone at www.LennoxPros.com for correct sizing information.

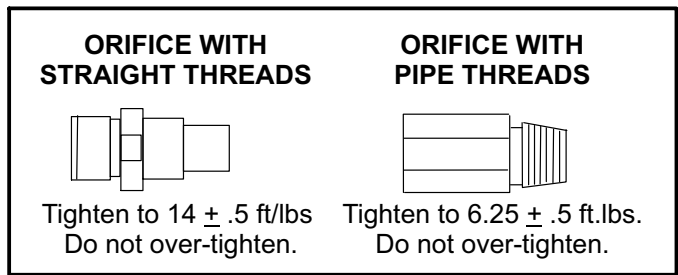

FIGURE 22

NOTE-In primary high temperature limits S10 and S99 the ignition circuits in both gas heat sections one and two are immediately de-energized when terminals 1-3 open and the indoor blower motor is immediately energized when terminals 1-2 close. This is the primary safety shut-down function of the unit.

4-Primary High Temperature Limits S10 & S99

S10 is the primary high temperature limit for gas heat section one, while S99 is the primary high temperature limit for gas heat section two.

Figure 23 shows the location of S10 and S99 on the drip shield behind the blower housing. In this location, S10 and S99 serve as both primary and secondary limit.

Primary limit S10 is wired to the Unit Controller A55 which energizes burner 1 control (A3), while primary limit S99 is wired to the Unit Controller A178 which energizes burner 2 control (A12). Its N.C. contacts open to de-energize the ignition control when excessive temperature is reached in the blower compartment. At the same time, the N.O. contacts of S10 and S99 close energizing the blower relay coil K3 through control A55. If either limit trips the blower will be energized. Limit setpoints are factory-set and cannot be adjusted. If limit must be replaced, same type and setpoint must be used. See Product Zone at www.LennoxPros.com.

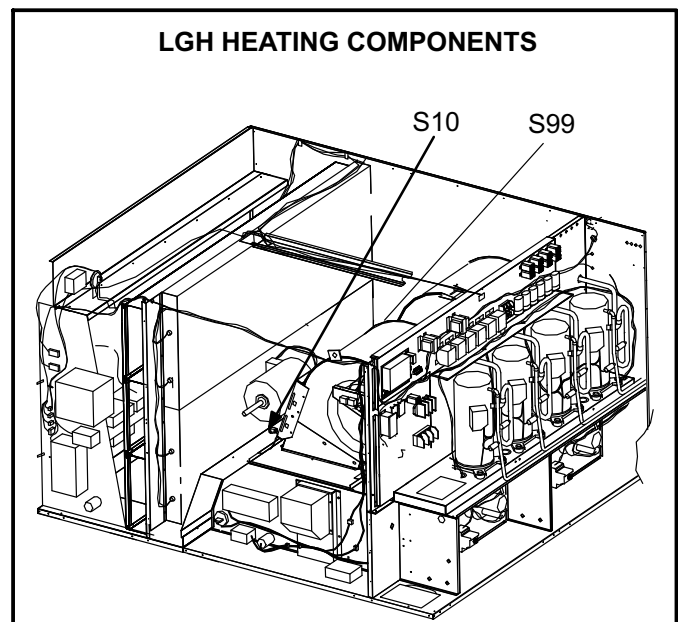

FIGURE 23

5-Flame Rollout Limits S47 and S69

Flame rollout limits S47 (first heat section) and S69 (second heat section) are SPST N.C. high temperature limits located just above the burner air intake opening in the burner enclosures (see figure 19). S47 and S69 are wired to the Unit Controller A55. When S47 or S69 senses flame rollout (indicating a blockage in the combustion air passages), the corresponding flame rollout limit trips, and the ignition control immediately closes the gas valve.

Limit S47 and S69 are factory preset to open at $290^{\circ}\text{F} \pm 12^{\circ}\text{F}$ ($143.3^{\circ}\text{C} \pm 6.7^{\circ}\text{C}$) on a temperature rise. All flame rollout limits are manual reset.

6-Combustion Air Prove Switches S18 & S45

Prove switches S18 (first heat section) and S45 (second heat section) are located in the compressor compartment. Switches are identical, SPST N.O. and monitor combustion air inducer operation. Switch S18 and S45 are wired to the Unit Controller A55. When the combustion air inducer is operating, a negative pressure is created in the compressor compartment. The switches close (on a pressure fall) allowing power to the heating sequence. When the combustion air inducer is not operating, the pressure builds in the compressor compartment. Switches open (on a pressure rise) to interrupt power to the heating sequence. The combustion air prove switches are factory-set and are not adjustable. Table 4 shows prove switch settings.

TABLE 4
S18 & S45 PROVE SWITCH SETTINGS

| Close "wc (Pa) | Open "wc (Pa) |
|------------------------------------|------------------------------------|
| $0.25 \pm .05$ (62.3 ± 12.4) | $0.10 \pm .05$ (24.8 ± 12.4) |

7-Combustion Air Inducers B6 and B15

Combustion air inducers B6 (first heat section) and B15 (second heat section) are identical inducers which provide fresh air to the corresponding burners while clearing the combustion chamber of exhaust gases. The inducers begin operating immediately upon receiving a thermostat demand and are de-energized immediately when thermostat demand is satisfied.

Combustion air inducers use a 208/230V or 460V single-phase PSC motor and a 4.81in. x 1.25in. (122mm x 32mm) blower wheel. All motors operate at 3200 or 3450 RPM and are equipped with auto-reset overload protection. Inducers are supplied by various manufacturers. Ratings may vary by manufacturer. Specific inducer electrical ratings can be found on the unit rating plate.

All combustion air inducer motors are sealed and cannot be oiled. The inducer cannot be adjusted but can be disassembled for cleaning.

8-Combustion Air Motor Capacitors C3 & C11

The combustion air inducer motors in all LGH units require run capacitors. Capacitor C3 is connected to combustion air inducer B6 and C11 is connected to combustion air inducer B15. Both capacitors are rated at 3 or 4 MFD for 208/230V inducers and 4 MFD for 460V inducers.

9-Gas Valves GV1 and GV3

Gas valves GV1 and GV3 are identical. The gas valves are two-stage redundant valves. Units are equipped with valves manufactured by Honeywell. Both first-stage (low fire) and second-stage (high fire) are quick opening (on and off in less than 3 seconds). On a call for first stage heat (low fire), the valve is energized by the ignition control simultaneously with the spark electrode. On a call for second stage heat (high fire), the second stage operator is energized directly from A55 (GV1) and (GV3). The valve is adjustable for both low fire and high fire. A manual shut-off knob is provided on the valve for shut-off. Manual shut-off knob immediately closes both stages without delay. Table 5 shows factory gas valve regulation for LGH series units. See table 6 for high altitude operating pressures.

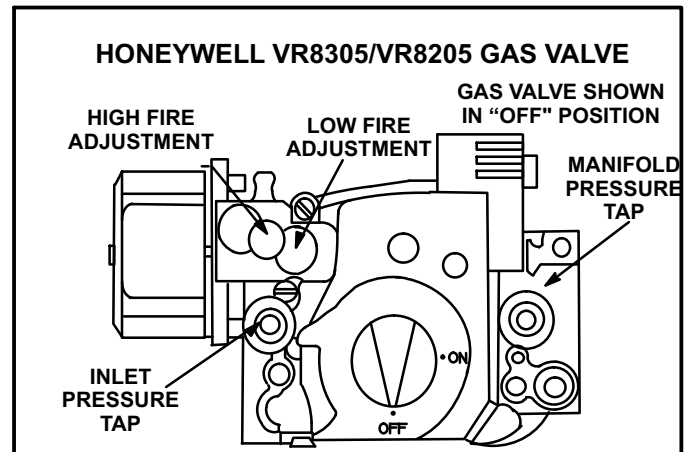

FIGURE 24

TABLE 5
GAS VALVE REGULATION FOR LGH UNITS

| Operating Pressure (outlet) Factory Setting | | | |
|---|--|---|---|
| Natural | | L.P. | |
| Low | High | Low | High |
| 1.6 ± 0.2 "W.C. 398 ± 50 Pa | 3.7 ± 0.3 "W.C. 920 ± 75 Pa | 5.5 ± 0.3 "W.C. 1368 ± 75 Pa | 10.5 ± 0.5 "W.C. 2611 ± 125 Pa |

TABLE 6
HIGH ALTITUDE DERATE

| Altitude Ft.* | Gas Manifold Pressure |
|----------------|--------------------------------------|
| 2000-4500 | See Unit Nameplate |
| 4500 And Above | Derate 2% / 1000 Ft. Above Sea Level |

*Units installed at 0-2000 feet do not need to be modified.

NOTE - This is the only permissible derate for these units.

10-Spark Electrodes

An electrode assembly is used for ignition spark. Two identical electrodes are used (one for each gas heat section). The electrode is mounted through holes on the left-most end of the burner support. The electrode tip protrudes into the flame envelope of the adjacent burner. The electrode assembly is fastened to burner supports and can be removed for service without removing any part of the burners.

During ignition, spark travels through the spark electrode (figure 25) and ignites the left burner. Flame travels from burner to burner until all are lit.

The spark electrode is connected to the ignition control by a 8 mm silicone-insulated stranded high voltage wire. The wire uses 1/4" (6.35 mm) female quick connect on the electrode end and female spark plug-type terminal on the ignition control end.

NOTE-IN ORDER TO MAXIMIZE SPARK ENERGY TO ELECTRODE, HIGH VOLTAGE WIRE SHOULD TOUCH UNIT CABINET AS LITTLE AS POSSIBLE.

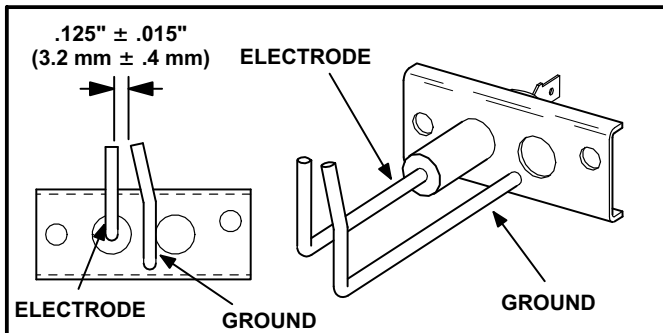

FIGURE 25

11-Flame Sensors

A flame sensor is located on the right side of each burner support. The sensor is mounted through a hole in the burner support and the tip protrudes into the flame envelope of the right most burner. The sensor assembly is fastened to burner supports and can be removed for service without removing any part of the burners. When flame is sensed by the flame sensor (indicated by microamp signal through the flame) sparking stops immediately. During operation, flame is sensed by current passed along the ground electrode (located on the spark electrode), through the flame and into the sensing electrode. The ignition control allows the gas valve to stay open as long as a flame signal (current passed through the flame) is sensed.

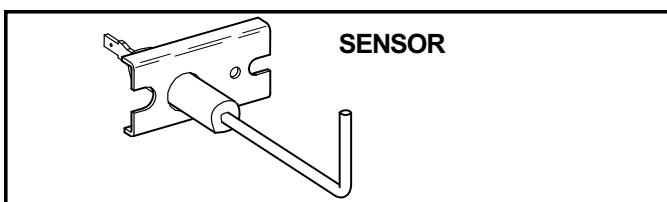

FIGURE 26

E-Optional Electric Heat Components

See ELECTRICAL/ELECTRIC HEAT DATA tables for possible LCH to EHA match-ups and electrical ratings. EHA parts arrangement is shown in figures 27 and 28. All electric heat sections consist of electric heating elements exposed directly to the air stream. Two electric heat sections (first section and second section) are used in all 30kW through 120kW heaters. See figure 29. Multiple-stage elements are sequenced on and off in response to thermostat demand.

1-Main Control Box Components

A55, K9, A178

The main control box (see figure 2) houses the A55, A178 Unit Controller and the K9 electric heat relay. For a description of the components see section I-A.

2-Terminal Block TB3

Electric heat line voltage connections are made to terminal block TB3 (or a fuse block on some models) located in the upper left corner of the electric heat vestibule.

3-Contactors K15, K16, K17 and K18

Contactors K15, K16, K17 and K18 are all three-pole double-break contactors located on the electric heat vestibule. K15 and K16 are located on the first electric heat section, while K17 and K18 are located on the second electric heat section. However, in the 30kW heaters, the first section houses all contactors and fuses. All contactors are equipped with a 24VAC coil. Contactors K15 and K17 energize the first stage heating elements, while K16 and K18 energize the second stage heating elements.

4-High Temperature Limits S15 and S107 (Primary)

S15 and S107 are SPST N.C. auto-reset thermostats located on the back panel of the electric heat section below the heating elements. S15 is the high temperature limit for the first electric heat section, while S107 is the high temperature limit for the second electric heat section. Both thermostats are identical and are wired to the A55 Unit Controller. When either S15 or S107 opens, indicating a problem in the system, contactor K15 is de-energized. When K15 is de-energized, first stage and all subsequent stages of heat are de-energized. The thermostats used on EHA360-45-2 Y/G/J volt are factory set to open at $200^{\circ}\text{F} \pm 5^{\circ}\text{F}$ ($93.3^{\circ}\text{C} \pm 2.8^{\circ}\text{C}$) on a temperature rise and automatically reset at $160^{\circ}\text{F} \pm 6^{\circ}\text{F}$ ($71.14^{\circ}\text{C} \pm 3.3^{\circ}\text{C}$) on a temperature fall. All other electric heat sections thermostats are factory-set to open at $170^{\circ}\text{F} \pm 5^{\circ}\text{F}$ ($76.7^{\circ}\text{C} \pm 2.8^{\circ}\text{C}$) on a temperature rise and automatically reset at $13^{\circ}\text{F} \pm 6^{\circ}\text{F}$ ($54.4^{\circ}\text{C} \pm 3.3^{\circ}\text{C}$) on a temperature fall. The thermostats are not adjustable.

5-Heating Elements HE1 through HE14

Heating elements are composed of helix wound bare nichrome wire exposed directly to the air stream. Three elements are connected in a three-phase arrangement. The elements in 208/230V units are connected in a "Delta" arrangement. Elements in 460 and 575V units are connected in "Wye" arrangement. See EHA wiring diagram in WIRING DIAGRAM AND OPERATION SEQUENCE section in back of this manual. Each stage is energized independently by the corresponding contactors located on the electric heat vestibule panel. Once energized, heat transfer is instantane-

ous. High temperature protection is provided by primary and redundant high temperature limits and overcurrent protection is provided by fuses.

6-Fuse F3

Fuse F3 are housed in a fuse block which holds three fuses. Each F3 fuse is connected in series with each leg of electric heat. Figure 28 and table 7 show the fuses used with each electric heat section. For simplicity, the service manual labels the fuses F3 - 1 through F3 - 8.

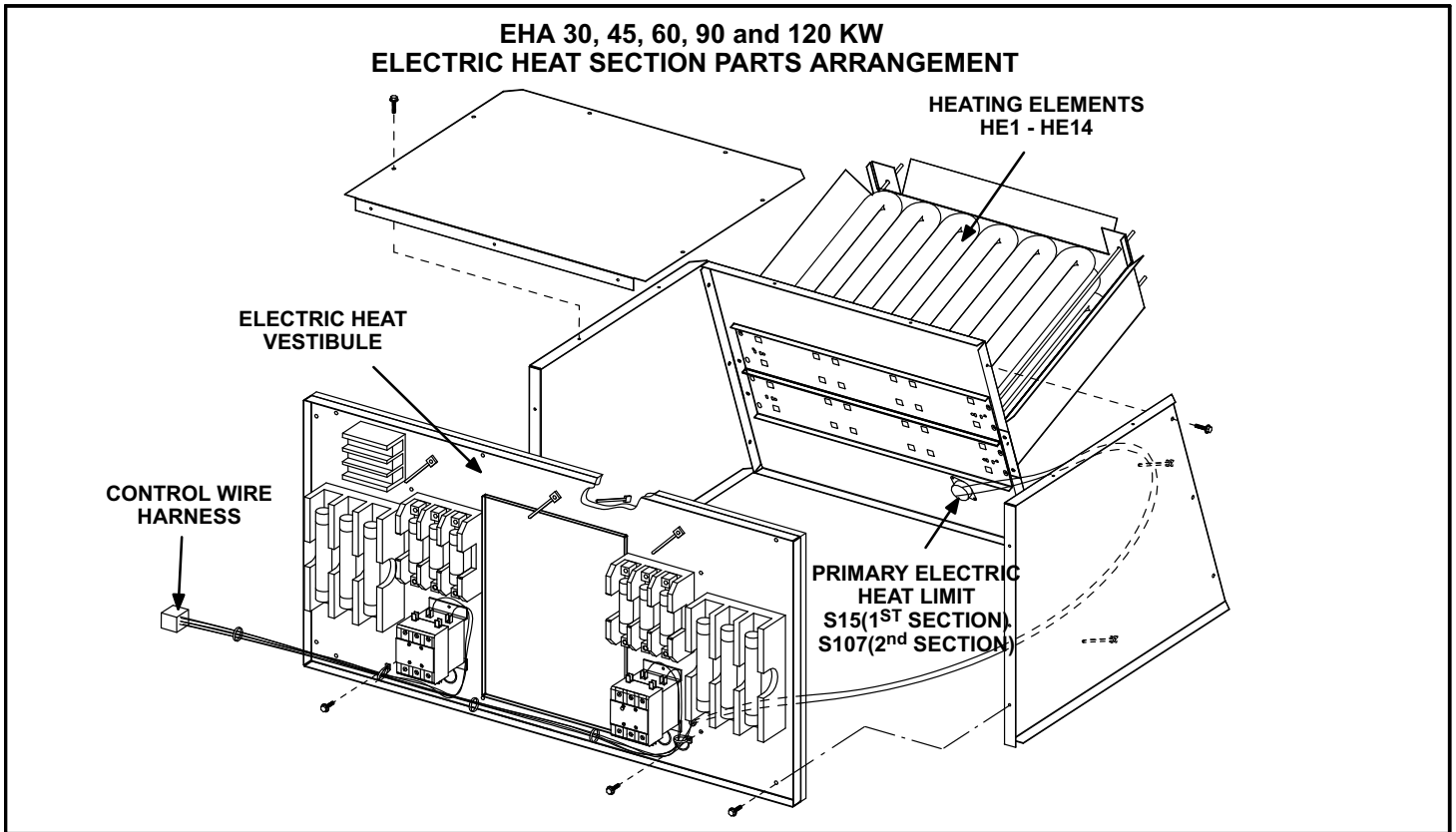
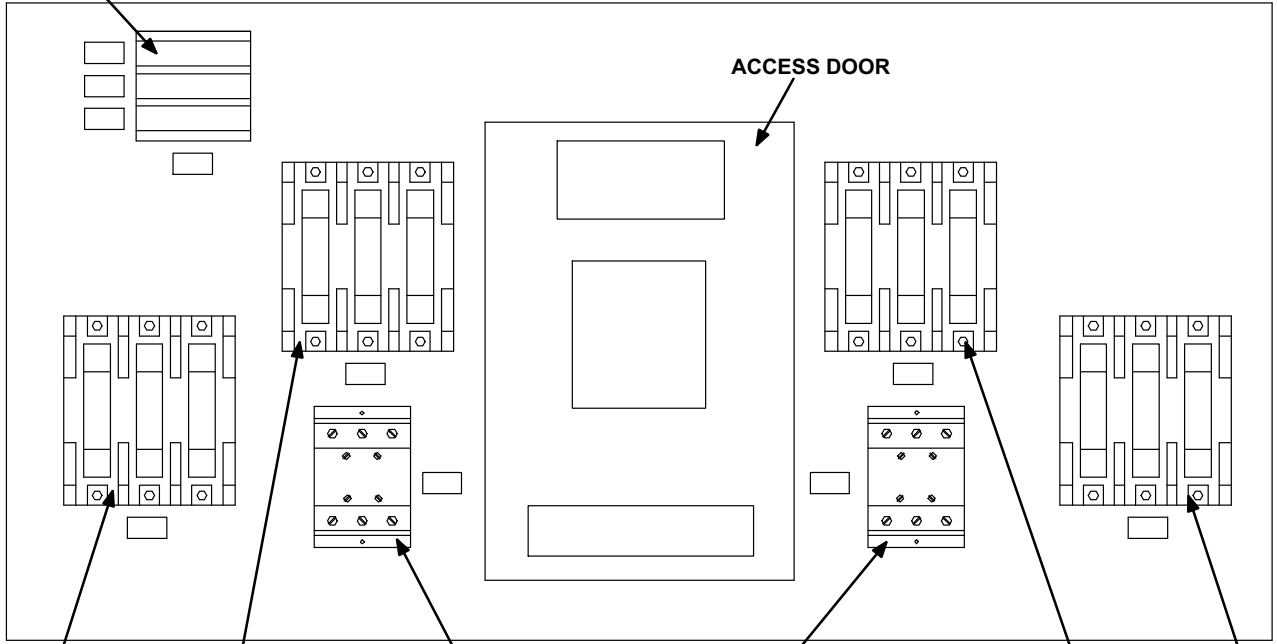

FIGURE 27

ELECTRIC HEAT VESTIBULE PARTS ARRANGEMENT

TERMINAL STRIP
(TB3)

FIRST HEAT SECTION (LEFT SIDE)



ACCESS DOOR

FUSE F3
F3 - 1

FUSE F3
F3 - 2

FIRST STAGE ELECTRIC
HEAT CONTACTOR K15

SECOND STAGE ELECTRIC
HEAT CONTACTOR K16

FUSE F3
F3 - 3

FUSE F3
F3 - 4

TERMINAL STRIP
(TB3)

SECOND HEAT SECTION (RIGHT SIDE)

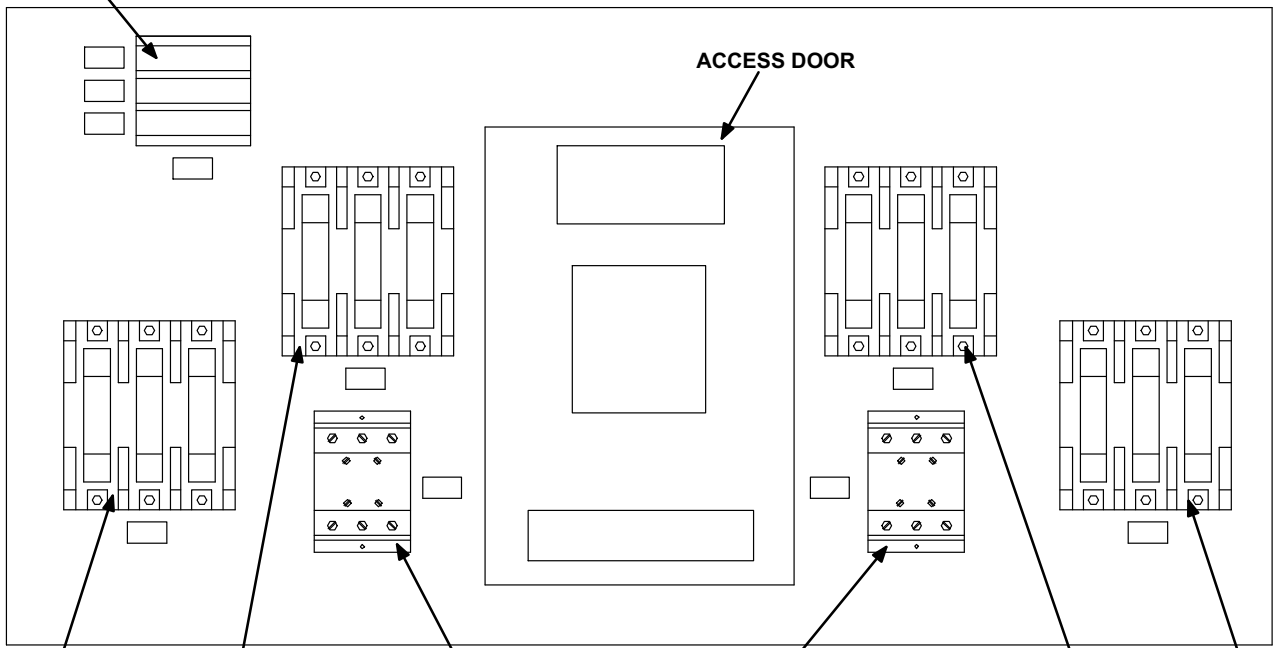

ACCESS DOOR

FUSE F3
F3 - 5

FUSE F3
F3 - 6

FIRST STAGE ELECTRIC
HEAT CONTACTOR K17

SECOND STAGE ELECTRIC
HEAT CONTACTOR K18

FUSE F3
F3 - 7

FUSE F3
F3 - 8

FIGURE 28

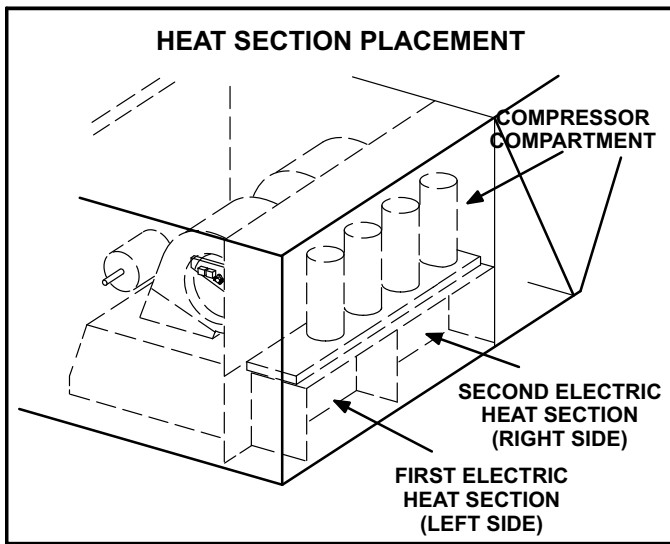

FIGURE 29

TABLE 7

| LCH ELECTRIC HEAT SECTION FUSE RATING | | | | | | | | | |
|---|----------|----------------|----------------|----------------|----------------|----------------|----------------|----------------|----------------|
| EHA QUANTITY & SIZE | VOLTAGES | FUSE (3 each) | | | | | | | |
| | | F3 - 1 | F3 - 2 | F3 - 3 | F3 - 4 | F3 - 5 | F3 - 6 | F3 - 7 | F3 - 8 |
| (1) EHA360-15 & (1) EHA360S-15 (30 kW Total) or (1) EHA156-15 & (1) EHA156S-15 | 208/230V | 60 Amp 250V | 60 Amp 250V | --- | --- | --- | --- | --- | --- |
| | 460V | 50 Amp 600V | --- | --- | --- | --- | --- | --- | --- |
| | 575V | 40 Amp 600V | --- | --- | --- | --- | --- | --- | --- |
| (2) EHA360-22.5 (45 kW Total) or (2) EHA156-22.5 | 208/230V | 50 Amp 250V | --- | --- | 25 Amp 250V | 50 Amp 250V | --- | --- | 25 Amp 250V |
| | 460V | 25 Amp 600V | --- | --- | 15 Amp 600V | 25 Amp 600V | --- | --- | 15 Amp 600V |
| | 575V | 20 Amp 600V | --- | --- | 10 Amp 600V | 20 Amp 600V | --- | --- | 10 Amp 600V |
| (2) EHA150-30 (60 kW Total) or (2) EHA156-30 | 208/230V | 50 Amp 250V | --- | --- | 50 Amp 250V | 50 Amp 250V | --- | --- | 50 Amp 250V |
| | 460V | 25 Amp 600V | --- | --- | 25 Amp 600V | 25 Amp 600V | --- | --- | 25 Amp 600V |
| | 575V | 20 Amp 600V | --- | --- | 20 Amp 600V | 20 Amp 600V | --- | --- | 20 Amp 600V |
| (2) EHA360-45 (90 kW Total) | 208/230V | 50 Amp 250V | --- | 60 Amp 250V | 60 Amp 250V | 50 Amp 250V | --- | 60 Amp 250V | 60 Amp 250V |
| | 460V | 25 Amp 600V | --- | --- | 50 Amp 600V | 25 Amp 600V | --- | --- | 50 Amp 600V |
| | 575V | 20 Amp 600V | --- | --- | 40 Amp 600V | 20 Amp 600V | --- | --- | 40 Amp 600V |
| (2) EHA150-60 (120 kW Total) | 208/230V | 60 Amp 250V | 60 Amp 250V | 60 Amp 250V | 60 Amp 250V | 60 Amp 250V | 60 Amp 250V | 60 Amp 250V | 60 Amp 250V |
| | 460V | 50 Amp 600V | --- | --- | 50 Amp 600V | 50 Amp 600V | --- | --- | 50 Amp 600V |
| | 575V | 40 Amp 600V | --- | --- | 40 Amp 600V | 40 Amp 600V | --- | --- | 40 Amp 600V |

II-PLACEMENT AND INSTALLATION

Make sure the unit is installed in accordance with the installation instructions and all applicable codes. See accessories section for conditions requiring use of the optional roof mounting frame (LARMF18/36 or LARMFH30/36).

III-STARTUP - OPERATION - CHARGING

IMPORTANT-The crankcase heater must be energized for 24 hours before attempting to start compressor. Set thermostat so there is no demand to prevent compressors from cycling.

WARNING

Refrigerant can be harmful if it is inhaled. Refrigerant must be used and recovered responsibly.

Failure to follow this warning may result in personal injury or death.

NOTE - These units must not be used as a "construction heater" at any time during any phase of construction. Very low return air temperatures, harmful vapors, and misplacement of the filters will damage the unit and its efficiency. Additionally, a unit which will be subject to cold temperatures when not in operation must have a vapor barrier installed to seal the duct connections. Failure to protect the unit from moisture laden air or harmful vapors (generated from the construction process and temporary combustion heating equipment) will cause corrosive condensation within the unit. Failure to properly protect the unit in this situation will cause electrical and electronic component failure and could affect the unit warranty status.

A-Preliminary Checks

- 1- Make sure that unit is installed in accordance with the installation instructions and applicable codes.
- 2- Inspect all electrical wiring, both field- and factory-installed, for loose connections. Tighten as required.
- 3- Check to ensure that refrigerant lines do not rub against the cabinet or against other refrigerant lines.
- 4- Check voltage at disconnect switch. Voltage must be within range listed on nameplate. If not, consult power company and have voltage condition corrected before starting unit.
- 5- Make sure filters are in place before start-up.

B-Cooling Start-Up

- 1- Initiate first and second stage cooling demands according to instructions provided with thermostat.
- 2- First-stage thermostat demand will energize compressors 1 and 2. Second-stage thermostat demand will energize compressors 3 and 4. On units with an economizer, when outdoor air is acceptable, a first-stage demand will energize the economizer; a second-stage demand will energize compressors 1 and 2.
- 3- Units contain four refrigerant circuits or systems. Evaporator and condenser coil refrigerant circuits 1 and 2 make up stage 1 cooling. Evaporator and condenser refrigerant circuits 3 and 4 make up stage 2 cooling. See figures 7 and 8.
- 4- Each refrigerant circuit is separately charged with R410A refrigerant. See unit rating plate for correct amount of charge.
- 5- Refer to Cooling Operation and Adjustment section for proper method to check refrigerant charge.

Three Phase Scroll Compressor Voltage Phasing

Three phase scroll compressors must be phased sequentially to ensure correct compressor and blower* rotation and operation. Compressor and blower are wired in phase at the factory. Power wires are color-coded as follows: line 1-red, line 2-yellow, line 3-blue.

- 1- Observe suction and discharge pressures and blower* rotation on unit start-up.
- 2- Suction pressure must drop, discharge pressure must rise, and blower rotation must match rotation marking.

If pressure differential is not observed or blower rotation is not correct:

- 3- Disconnect all remote electrical power supplies.
- 4- Reverse any two field-installed wires connected to the line side of S48 disconnect or TB13 terminal strip. Do not reverse wires at blower contactor.
- 5- Make sure the connections are tight.

Discharge and suction pressures should operate at their normal start-up ranges.

*Supply air VFD motors should always rotate in the correct direction regardless of voltage phasing. Verify scroll compressor rotation separately. Contact technical support if the VFD blower is rotating incorrectly.

R410A Refrigerant

Units charged with R410A refrigerant operate at much higher pressures than R22. The expansion valve and liquid line drier provided with the unit are approved for use with R410A. Do not replace them with components designed for use with R22.

R410A refrigerant is stored in a pink cylinder.

⚠ IMPORTANT

Mineral oils are not compatible with R410A. If oil must be added, it must be a polyol ester oil.

Manifold gauge sets used with systems charged with R410A refrigerant must be capable of handling the higher system operating pressures. The gauges should be rated for use with pressures of 0-800 on the high side and a low side of 30" vacuum to 250 psi with dampened speed to 500 psi. Gauge hoses must be rated for use at up to 800 psi of pressure with a 4000 psi burst rating.

Turn off power to the unit.

C-Refrigerant Charge and Check

WARNING-Do not exceed nameplate charge under any condition.

This unit is factory charged and should require no further adjustment. If the system requires additional refrigerant, reclaim the charge, evacuate the system, and add required nameplate charge.

*NOTE - System charging is not recommended below 60°F (15°C). In temperatures below 60°F (15°C), the charge **must** be weighed into the system.*

If weighing facilities are not available, or to check the charge, use the following procedure:

IMPORTANT - Charge unit in standard cooling mode.

- 1- Make sure outdoor coil is clean. Attach gauge manifolds and operate unit at full CFM in cooling mode with

economizer disabled until system stabilizes (approximately five minutes). Make sure all outdoor air dampers are closed.

- 2- Check each system separately with all stages operating. Compare the normal operating pressures (see tables 8 - 12) to the pressures obtained from the gauges. Check unit components if there are significant differences.
- 3- Measure the outdoor ambient temperature and the suction pressure. Refer to the appropriate circuit charging curve to determine a target liquid temperature.

Note - Pressures are listed for sea level applications.

- 4- Use the same thermometer to accurately measure the liquid temperature (near the liquid service tap).
 - If measured liquid temperature is higher than the target liquid temperature, add refrigerant to the system.
 - If measured liquid temperature is lower than the target liquid temperature, recover some refrigerant from the system.
- 5- Add or remove charge in increments. Allow the system to stabilize each time refrigerant is added or removed.
- 6- Continue the process until measured liquid temperature agrees with the target liquid temperature. Do not go below the target liquid temperature when adjusting charge. Note that suction pressure can change as charge is adjusted.
- 7- Example LGH/LCH242H Circuit 1: At 95°F outdoor ambient and a measured suction pressure of 130psig, the target liquid temperature is 98°F. For a measured liquid temperature of 106°F, add charge in increments until measured liquid temperature agrees with the target liquid temperature.

TABLE 8

| LGH/LCH242 VAV Normal Operating Pressures | | | | | | | | | | | | |
|--|---------------------------------------|-------------|-------------|-------------|-------------|-------------|-------------|-------------|-------------|-------------|-------------|-------------|
| | Outdoor Coil Entering Air Temperature | | | | | | | | | | | |
| | 65 °F | | 75 °F | | 85 °F | | 95 °F | | 105 °F | | 115 °F | |
| | Suct (psig) | Disc (psig) | Suct (psig) | Disc (psig) | Suct (psig) | Disc (psig) | Suct (psig) | Disc (psig) | Suct (psig) | Disc (psig) | Suct (psig) | Disc (psig) |
| Circuit 1 | 97 | 232 | 99 | 268 | 102 | 309 | 104 | 358 | 104 | 407 | 109 | 465 |
| | 106 | 234 | 109 | 269 | 111 | 310 | 113 | 358 | 116 | 409 | 118 | 467 |
| | 129 | 241 | 126 | 275 | 129 | 318 | 132 | 363 | 134 | 416 | 139 | 469 |
| | 148 | 247 | 152 | 283 | 148 | 325 | 152 | 372 | 154 | 422 | 158 | 475 |
| Circuit 2 | 103 | 225 | 104 | 263 | 107 | 303 | 108 | 353 | 108 | 407 | 113 | 471 |
| | 110 | 227 | 113 | 262 | 116 | 305 | 117 | 354 | 119 | 407 | 122 | 473 |
| | 133 | 236 | 130 | 267 | 133 | 313 | 135 | 358 | 138 | 414 | 141 | 475 |
| | 151 | 243 | 155 | 275 | 152 | 319 | 155 | 366 | 158 | 420 | 160 | 478 |
| Circuit 3 | 117 | 237 | 118 | 273 | 120 | 321 | 122 | 370 | 123 | 422 | 125 | 478 |
| | 126 | 239 | 128 | 272 | 130 | 322 | 131 | 371 | 133 | 422 | 135 | 479 |
| | 149 | 245 | 148 | 280 | 149 | 328 | 151 | 376 | 153 | 430 | 157 | 483 |
| | 169 | 254 | 173 | 288 | 170 | 335 | 173 | 383 | 176 | 435 | 179 | 485 |
| Circuit 3 | 118 | 234 | 120 | 271 | 122 | 313 | 124 | 361 | 124 | 409 | 129 | 471 |
| | 127 | 236 | 129 | 270 | 131 | 317 | 133 | 364 | 136 | 411 | 139 | 475 |
| | 150 | 244 | 149 | 277 | 150 | 325 | 153 | 370 | 156 | 421 | 159 | 476 |
| | 169 | 254 | 172 | 289 | 172 | 331 | 174 | 379 | 178 | 428 | 180 | 482 |

TABLE 9

| LGH/LCH300H CAV Normal Operating Pressures | | | | | | | | | | | | |
|---|---------------------------------------|-------------|-------------|-------------|-------------|-------------|-------------|-------------|-------------|-------------|-------------|-------------|
| | Outdoor Coil Entering Air Temperature | | | | | | | | | | | |
| | 65 °F | | 75 °F | | 85 °F | | 95 °F | | 105 °F | | 115 °F | |
| | Suct (psig) | Disc (psig) | Suct (psig) | Disc (psig) | Suct (psig) | Disc (psig) | Suct (psig) | Disc (psig) | Suct (psig) | Disc (psig) | Suct (psig) | Disc (psig) |
| Circuit 1 | 103 | 243 | 105 | 282 | 108 | 327 | 110 | 377 | 112 | 429 | 114 | 489 |
| | 112 | 244 | 114 | 283 | 116 | 327 | 119 | 378 | 121 | 432 | 124 | 489 |
| | 131 | 251 | 133 | 289 | 136 | 334 | 138 | 383 | 140 | 434 | 143 | 496 |
| | 147 | 259 | 154 | 299 | 157 | 342 | 160 | 390 | 163 | 444 | 167 | 499 |
| Circuit 2 | 105 | 251 | 108 | 291 | 109 | 337 | 112 | 391 | 113 | 456 | 115 | 552 |
| | 114 | 254 | 116 | 293 | 118 | 339 | 120 | 392 | 122 | 453 | 125 | 537 |
| | 135 | 258 | 137 | 297 | 138 | 343 | 140 | 394 | 142 | 449 | 144 | 520 |
| | 150 | 268 | 158 | 306 | 161 | 351 | 165 | 399 | 167 | 455 | 168 | 513 |
| Circuit 3 | 107 | 237 | 109 | 277 | 111 | 323 | 112 | 379 | 114 | 434 | 117 | 494 |
| | 116 | 239 | 118 | 280 | 120 | 324 | 122 | 377 | 124 | 432 | 126 | 495 |
| | 136 | 245 | 138 | 285 | 140 | 330 | 142 | 381 | 144 | 431 | 146 | 499 |
| | 151 | 250 | 159 | 295 | 161 | 339 | 164 | 387 | 166 | 443 | 169 | 502 |
| Circuit 4 | 102 | 252 | 105 | 293 | 108 | 328 | 110 | 393 | 112 | 449 | 114 | 523 |
| | 109 | 256 | 114 | 297 | 116 | 345 | 118 | 399 | 121 | 455 | 123 | 529 |
| | 130 | 261 | 133 | 303 | 135 | 348 | 137 | 402 | 139 | 456 | 141 | 525 |
| | 148 | 266 | 156 | 312 | 158 | 358 | 161 | 407 | 163 | 464 | 166 | 526 |

TABLE 10

| LGH/LCH300H VAV/STAGED SUPPLY AIR Normal Operating Pressures | | | | | | | | | | | | |
|---|---------------------------------------|-------------|-------------|-------------|-------------|-------------|-------------|-------------|-------------|-------------|-------------|-------------|
| | Outdoor Coil Entering Air Temperature | | | | | | | | | | | |
| | 65 °F | | 75 °F | | 85 °F | | 95 °F | | 105 °F | | 115 °F | |
| | Suct (psig) | Disc (psig) | Suct (psig) | Disc (psig) | Suct (psig) | Disc (psig) | Suct (psig) | Disc (psig) | Suct (psig) | Disc (psig) | Suct (psig) | Disc (psig) |
| Circuit 1 | 91 | 273 | 96 | 304 | 99 | 354 | 102 | 400 | 106 | 451 | 114 | 505 |
| | 102 | 278 | 107 | 315 | 110 | 356 | 112 | 404 | 114 | 455 | 119 | 509 |
| | 120 | 287 | 124 | 323 | 127 | 368 | 130 | 409 | 132 | 460 | 138 | 522 |
| | 140 | 297 | 142 | 332 | 146 | 372 | 151 | 422 | 154 | 467 | 158 | 525 |
| Circuit 2 | 100 | 264 | 105 | 306 | 104 | 345 | 107 | 393 | 109 | 450 | 112 | 514 |
| | 107 | 269 | 111 | 306 | 113 | 348 | 116 | 395 | 118 | 452 | 121 | 515 |
| | 125 | 276 | 128 | 312 | 131 | 357 | 134 | 399 | 137 | 451 | 140 | 517 |
| | 146 | 284 | 148 | 318 | 151 | 359 | 155 | 410 | 158 | 456 | 161 | 520 |
| Circuit 3 | 114 | 279 | 117 | 317 | 120 | 366 | 122 | 417 | 125 | 475 | 129 | 539 |
| | 124 | 282 | 128 | 323 | 130 | 370 | 132 | 420 | 134 | 478 | 137 | 539 |
| | 144 | 294 | 146 | 332 | 149 | 378 | 151 | 423 | 153 | 478 | 158 | 542 |
| | 151 | 298 | 167 | 339 | 170 | 383 | 174 | 436 | 177 | 484 | 181 | 546 |
| Circuit 4 | 116 | 268 | 122 | 311 | 121 | 349 | 123 | 397 | 125 | 452 | 128 | 508 |
| | 125 | 270 | 128 | 309 | 130 | 353 | 132 | 400 | 135 | 454 | 136 | 512 |
| | 143 | 283 | 145 | 319 | 148 | 364 | 151 | 405 | 154 | 455 | 156 | 519 |
| | 151 | 288 | 165 | 327 | 169 | 369 | 173 | 419 | 176 | 466 | 179 | 525 |

TABLE 11

| LGH/LCH360 CAV Normal Operating Pressures | | | | | | | | | | | | |
|--|---------------------------------------|-------------|-------------|-------------|-------------|-------------|-------------|-------------|-------------|-------------|-------------|-------------|
| | Outdoor Coil Entering Air Temperature | | | | | | | | | | | |
| | 65 °F | | 75 °F | | 85 °F | | 95 °F | | 105 °F | | 115 °F | |
| | Suct (psig) | Disc (psig) | Suct (psig) | Disc (psig) | Suct (psig) | Disc (psig) | Suct (psig) | Disc (psig) | Suct (psig) | Disc (psig) | Suct (psig) | Disc (psig) |
| Circuit 1 | 96 | 254 | 102 | 295 | 105 | 338 | 107 | 393 | 107 | 446 | 111 | 511 |
| | 106 | 260 | 111 | 298 | 112 | 345 | 115 | 395 | 117 | 448 | 120 | 508 |
| | 126 | 267 | 131 | 307 | 133 | 356 | 135 | 399 | 137 | 456 | 140 | 511 |
| | 144 | 275 | 151 | 318 | 154 | 360 | 157 | 412 | 159 | 462 | 162 | 525 |
| Circuit 2 | 98 | 255 | 104 | 301 | 106 | 349 | 108 | 405 | 109 | 477 | 113 | 563 |
| | 108 | 262 | 112 | 305 | 114 | 353 | 116 | 408 | 118 | 468 | 121 | 547 |
| | 129 | 272 | 133 | 313 | 135 | 363 | 136 | 407 | 138 | 468 | 141 | 532 |
| | 146 | 279 | 154 | 326 | 156 | 369 | 159 | 423 | 160 | 474 | 162 | 540 |
| Circuit 3 | 99 | 253 | 108 | 299 | 110 | 345 | 112 | 400 | 113 | 452 | 116 | 525 |
| | 110 | 256 | 116 | 302 | 118 | 348 | 120 | 398 | 122 | 452 | 125 | 518 |
| | 132 | 266 | 137 | 314 | 139 | 362 | 140 | 405 | 142 | 460 | 145 | 522 |
| | 148 | 281 | 156 | 326 | 159 | 372 | 162 | 425 | 164 | 478 | 166 | 537 |
| Circuit 4 | 102 | 258 | 104 | 313 | 106 | 359 | 110 | 414 | 110 | 471 | 114 | 544 |
| | 112 | 267 | 112 | 320 | 115 | 366 | 116 | 418 | 118 | 471 | 121 | 539 |
| | 130 | 287 | 133 | 330 | 136 | 378 | 137 | 422 | 138 | 479 | 142 | 541 |
| | 148 | 298 | 153 | 345 | 157 | 392 | 159 | 444 | 162 | 497 | 163 | 558 |

TABLE 12

LGH/LCH360 VAV/STAGED SUPPLY AIR Normal Operating Pressures

| | Outdoor Coil Entering Air Temperature | | | | | | | | | | | |
|-----------|---------------------------------------|-------------|-------------|-------------|-------------|-------------|-------------|-------------|-------------|-------------|-------------|-------------|
| | 65 °F | | 75 °F | | 85 °F | | 95 °F | | 105 °F | | 115 °F | |
| | Suct (psig) | Disc (psig) | Suct (psig) | Disc (psig) | Suct (psig) | Disc (psig) | Suct (psig) | Disc (psig) | Suct (psig) | Disc (psig) | Suct (psig) | Disc (psig) |
| Circuit 1 | 88 | 252 | 90 | 301 | 97 | 351 | 98 | 388 | 102 | 450 | 104 | 516 |
| | 100 | 255 | 102 | 305 | 105 | 355 | 107 | 403 | 111 | 456 | 113 | 523 |
| | 115 | 268 | 119 | 314 | 123 | 361 | 125 | 403 | 129 | 463 | 129 | 527 |
| | 133 | 282 | 137 | 327 | 140 | 371 | 144 | 425 | 147 | 473 | 152 | 544 |
| Circuit 2 | 97 | 257 | 100 | 303 | 102 | 349 | 104 | 385 | 106 | 447 | 107 | 524 |
| | 104 | 256 | 107 | 305 | 110 | 353 | 112 | 399 | 115 | 451 | 117 | 523 |
| | 121 | 270 | 125 | 313 | 128 | 355 | 130 | 397 | 134 | 454 | 134 | 521 |
| | 135 | 280 | 140 | 322 | 145 | 364 | 148 | 416 | 151 | 464 | 154 | 535 |
| Circuit 3 | 106 | 272 | 110 | 319 | 115 | 366 | 116 | 404 | 118 | 469 | 120 | 537 |
| | 118 | 266 | 120 | 320 | 123 | 375 | 124 | 422 | 127 | 472 | 130 | 545 |
| | 137 | 285 | 139 | 332 | 142 | 379 | 144 | 418 | 147 | 477 | 148 | 544 |
| | 155 | 294 | 158 | 344 | 161 | 393 | 164 | 443 | 167 | 492 | 172 | 563 |
| Circuit 4 | 113 | 258 | 115 | 304 | 117 | 349 | 119 | 384 | 121 | 445 | 123 | 511 |
| | 119 | 253 | 122 | 305 | 125 | 356 | 128 | 399 | 130 | 450 | 132 | 520 |
| | 138 | 280 | 142 | 320 | 145 | 359 | 147 | 400 | 149 | 456 | 151 | 521 |
| | 156 | 293 | 159 | 333 | 163 | 374 | 166 | 424 | 169 | 471 | 173 | 539 |

LGH/LCH242 VAV Circuit 1 Charging Curve

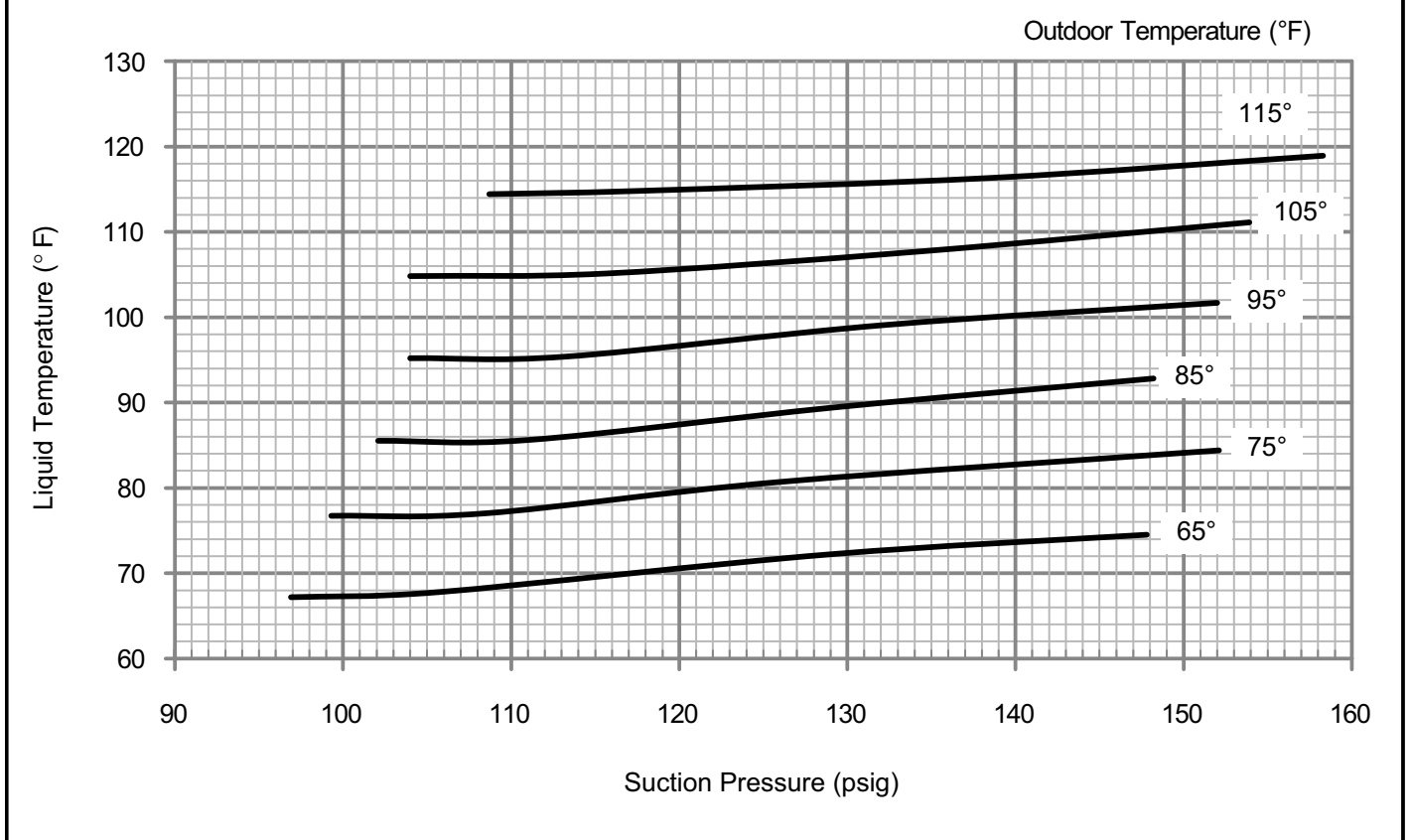

LGH/LCH242 VAV Circuit 2 Charging Curve

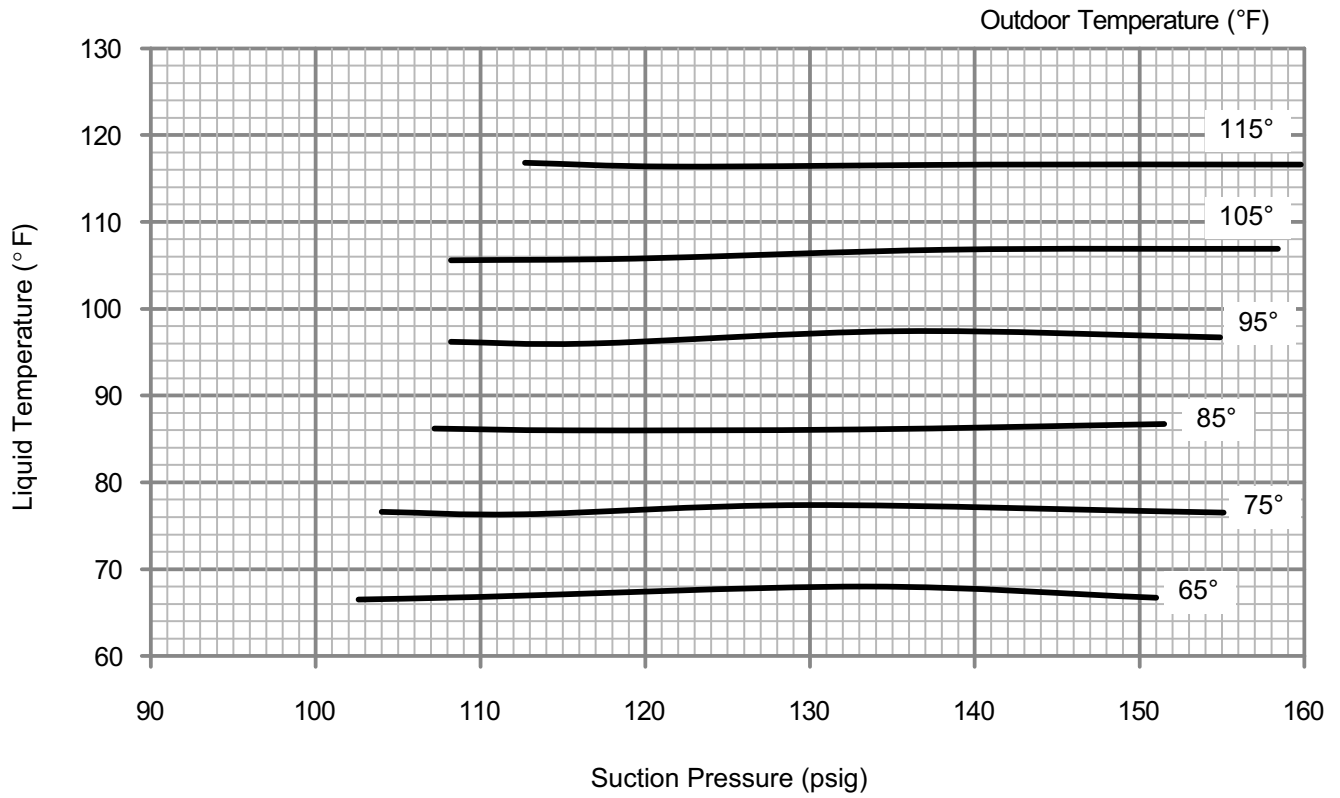

LGH/LCH242 VAV Circuit 3 Charging Curve

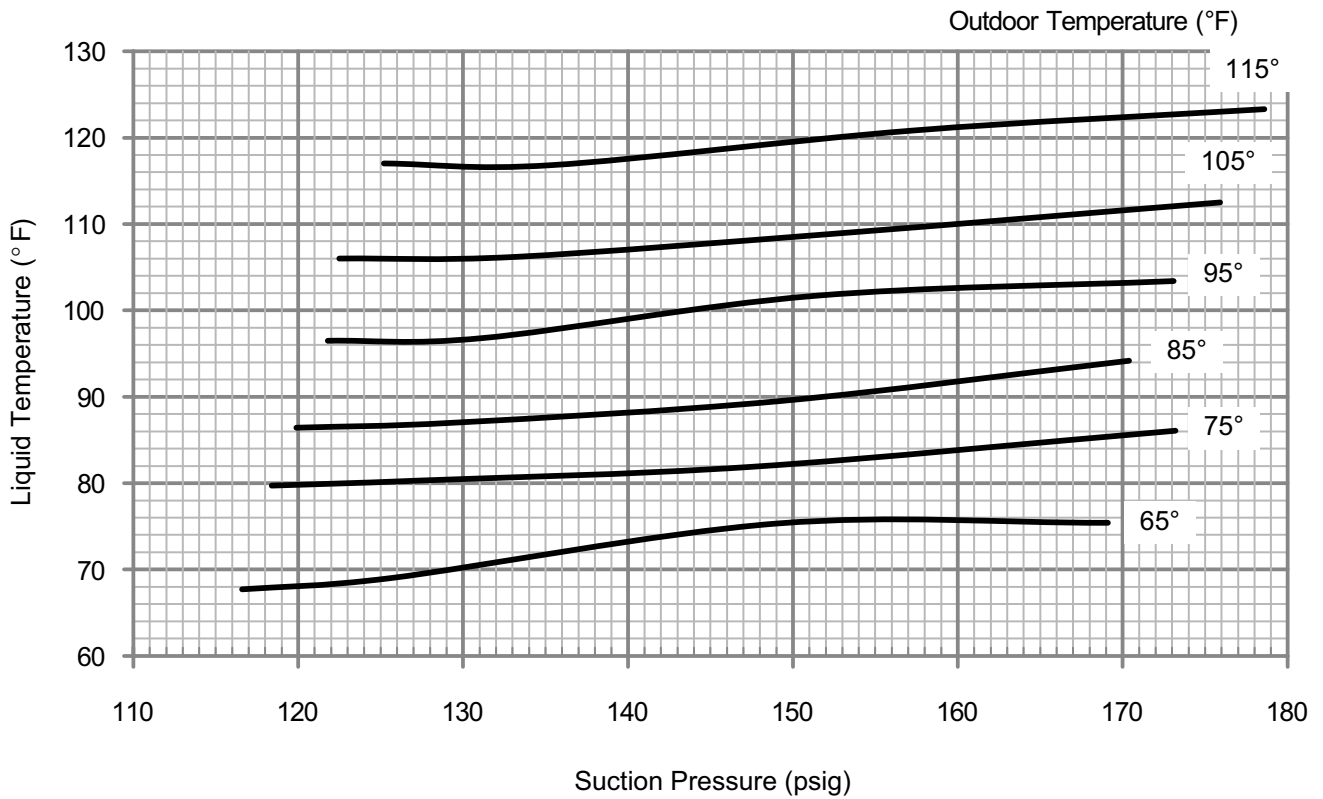

LGH/LCH242 VAV Circuit 4 Charging Curve

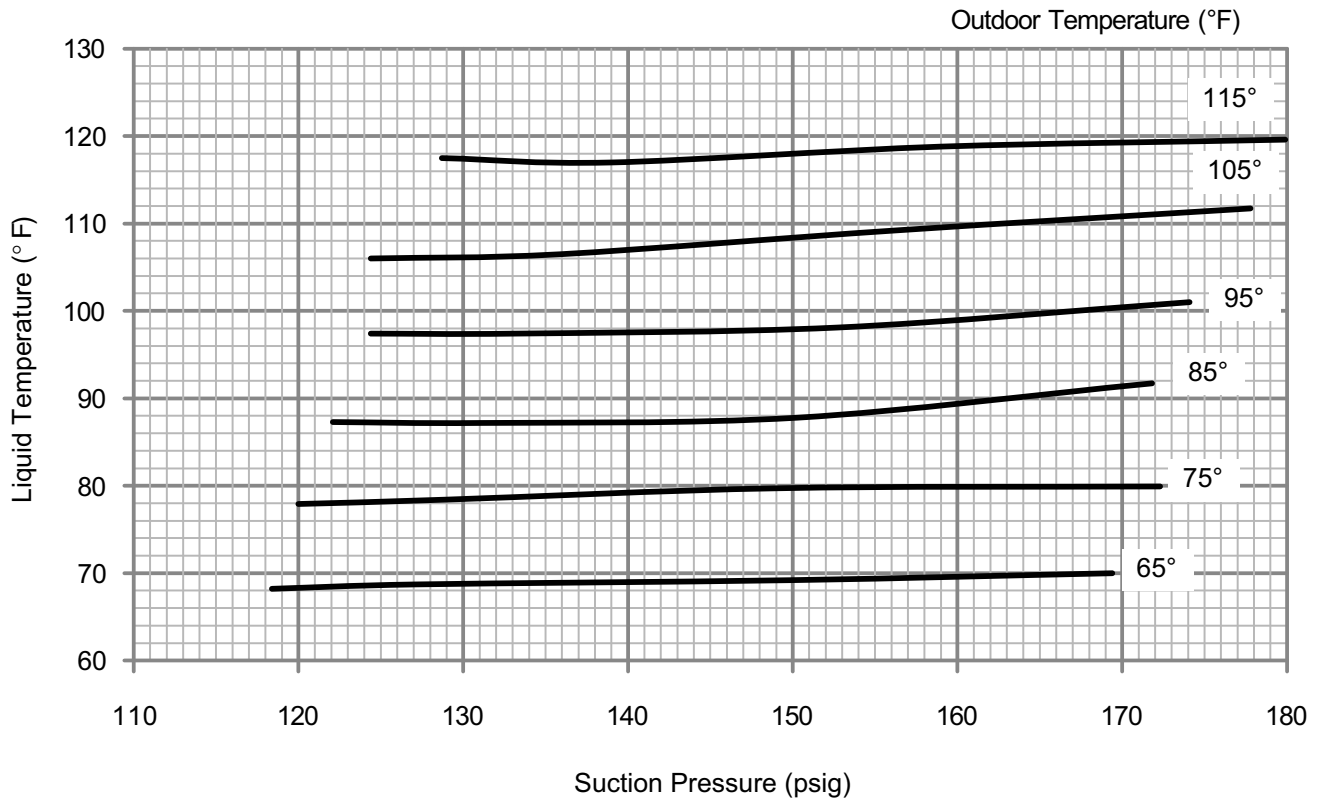

LGH/LCH300H CAV Circuit 1 Charging Curve

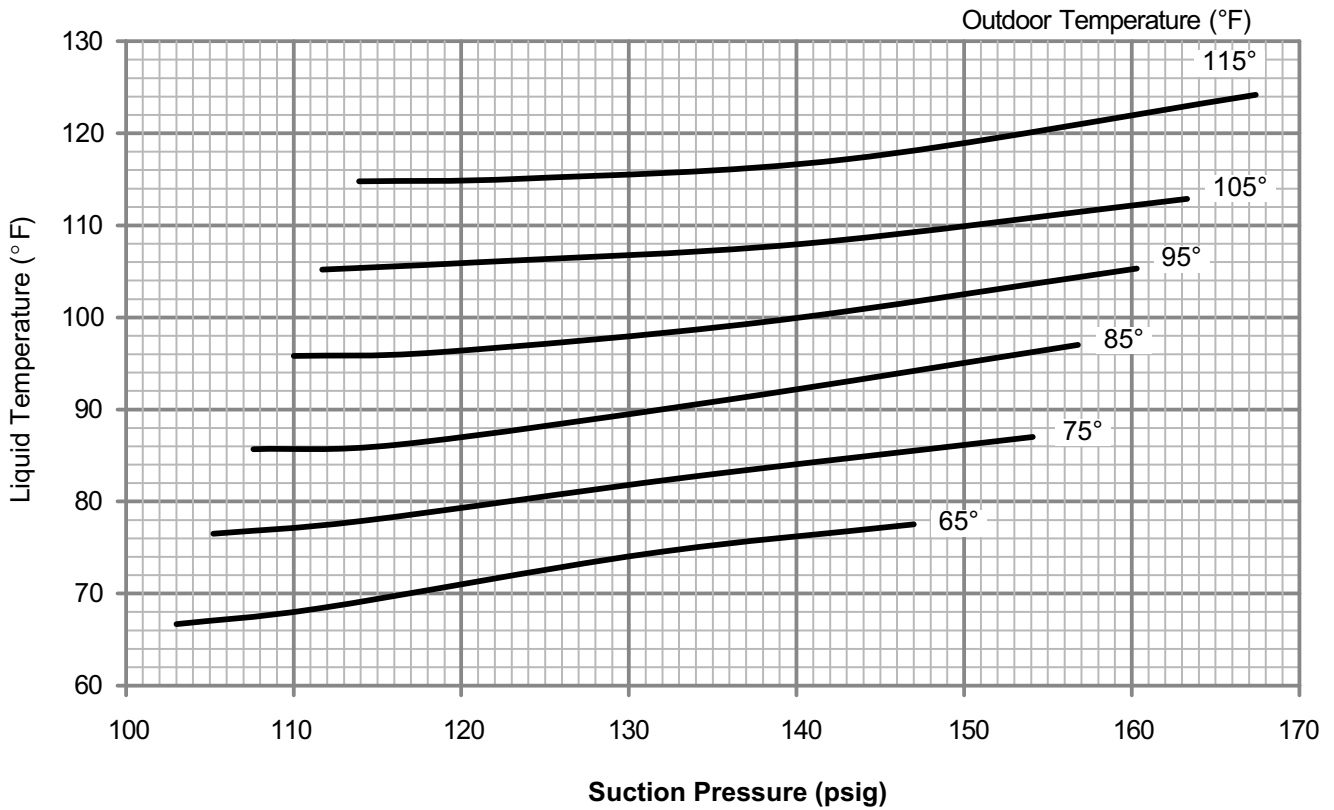

LGH/LCH300H CAV Circuit 2 Charging Curve

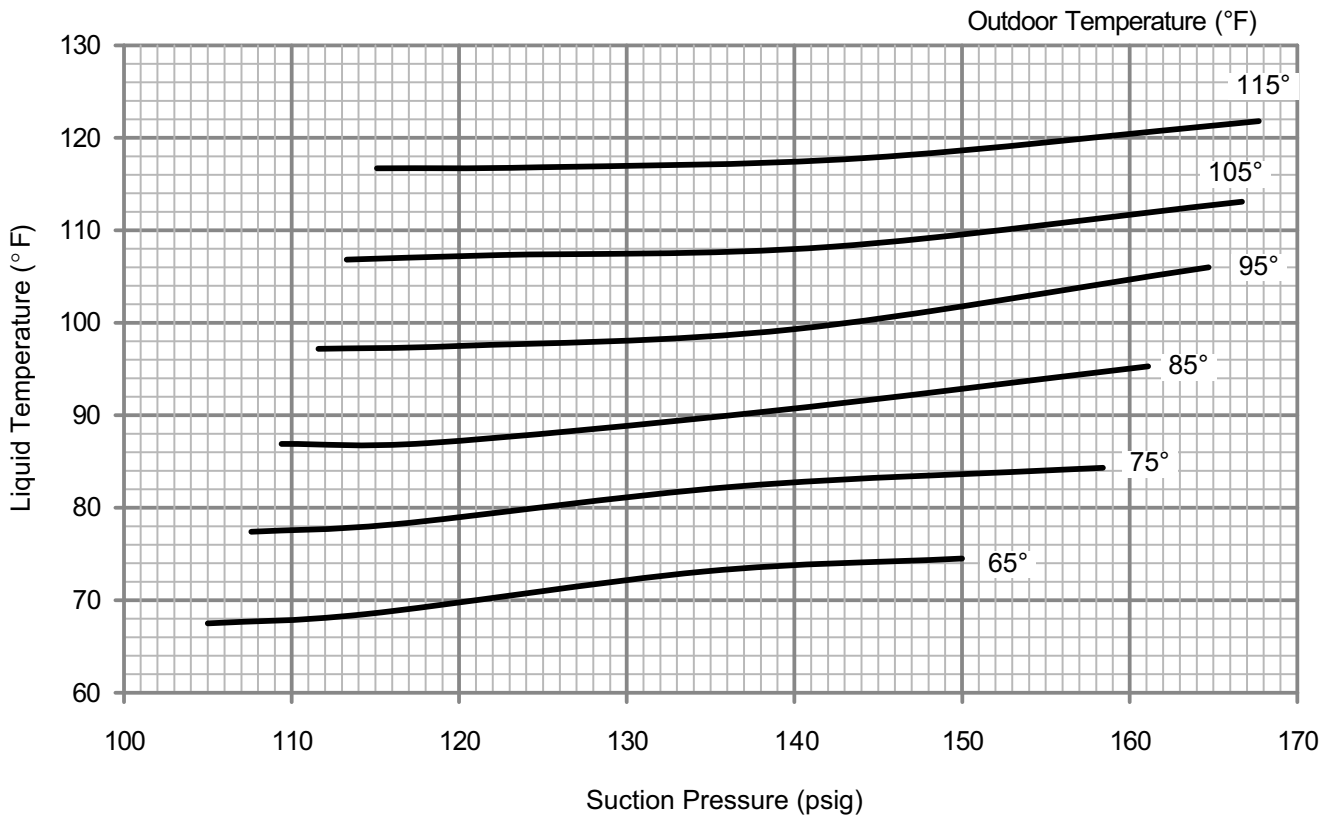

LGH/LCH300H CAV Circuit 3 Charging Curve

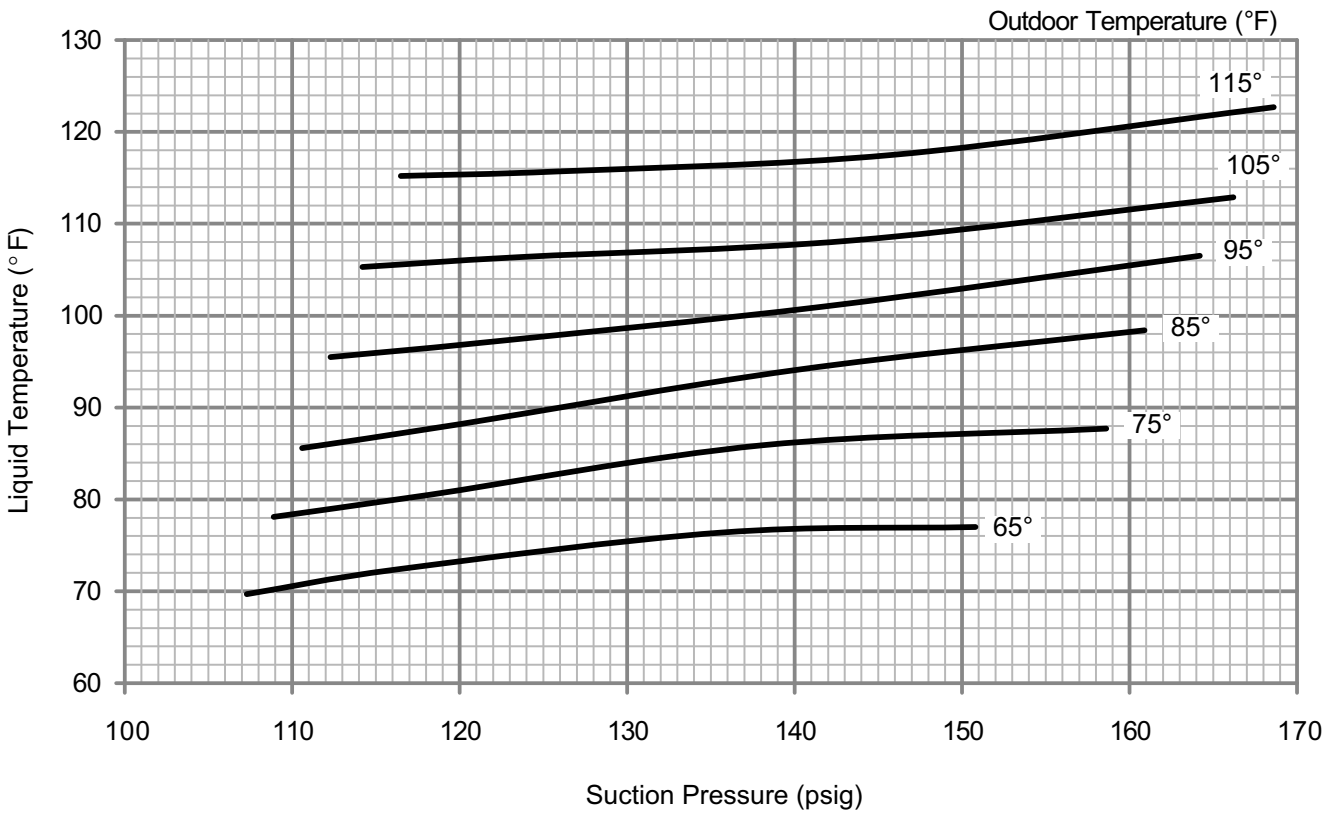

LGH/LCH300H CAV Circuit 4 Charging Curve

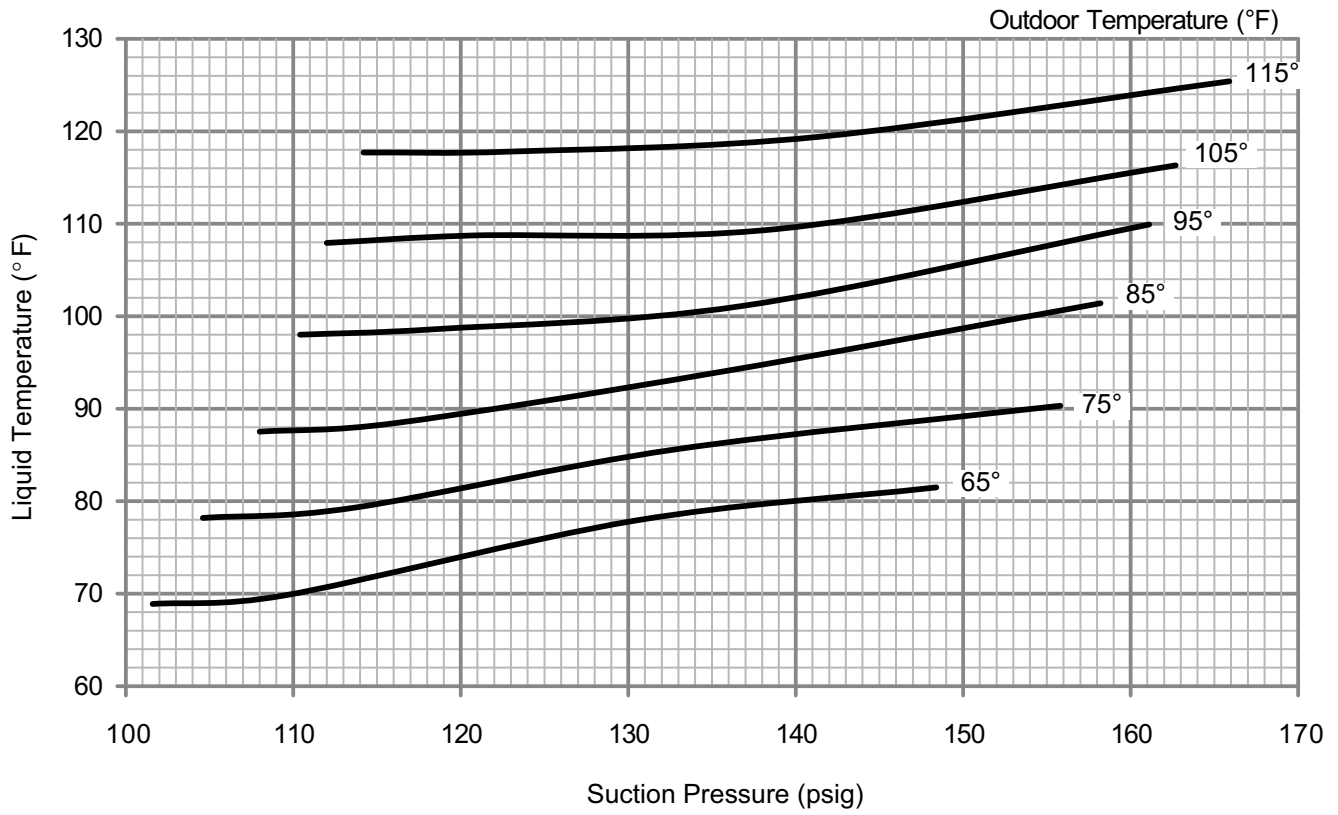

LGH/LCH300H VAV/STAGED SUPPLY AIR Circuit 1 Charging Curve

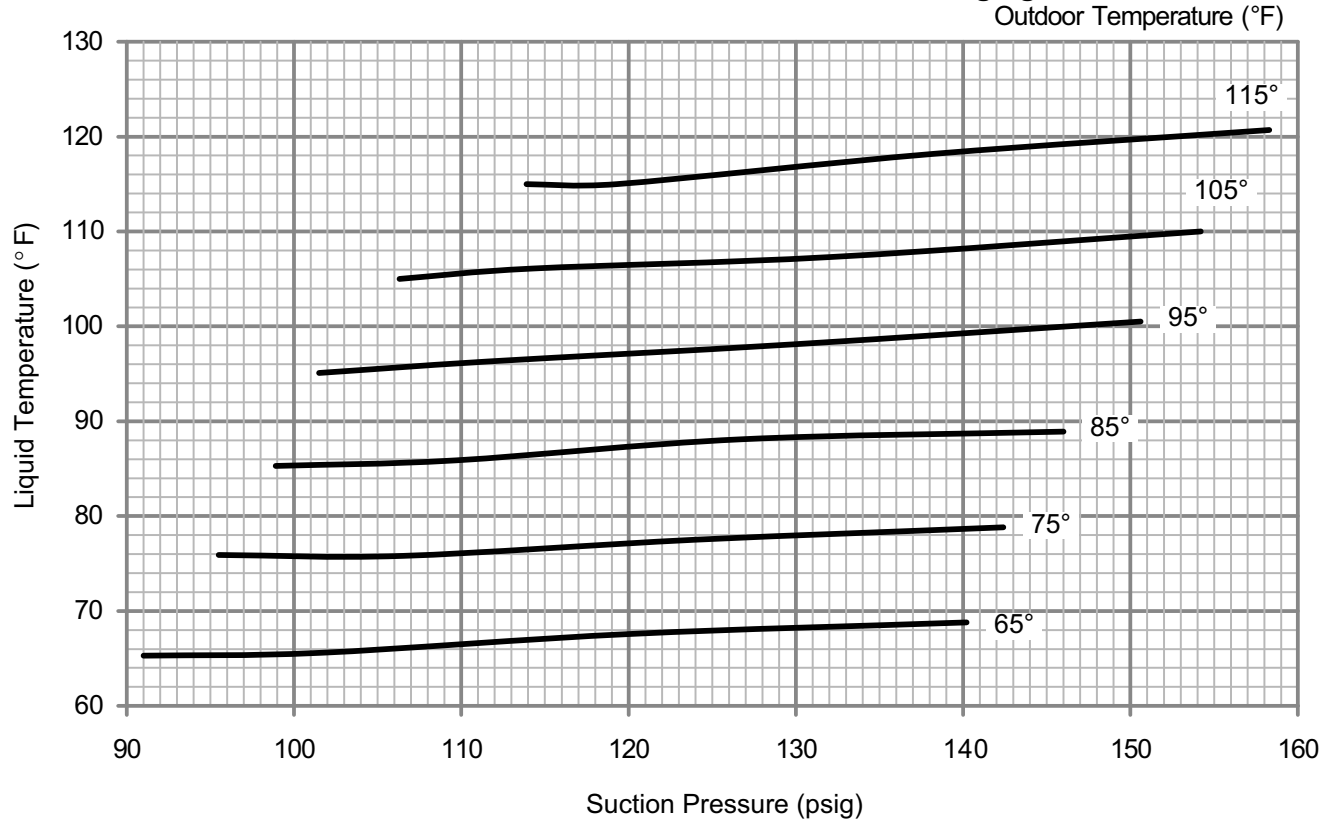

LGH/LCH300H VAV/STAGED SUPPLY AIR Circuit 2 Charging Curve

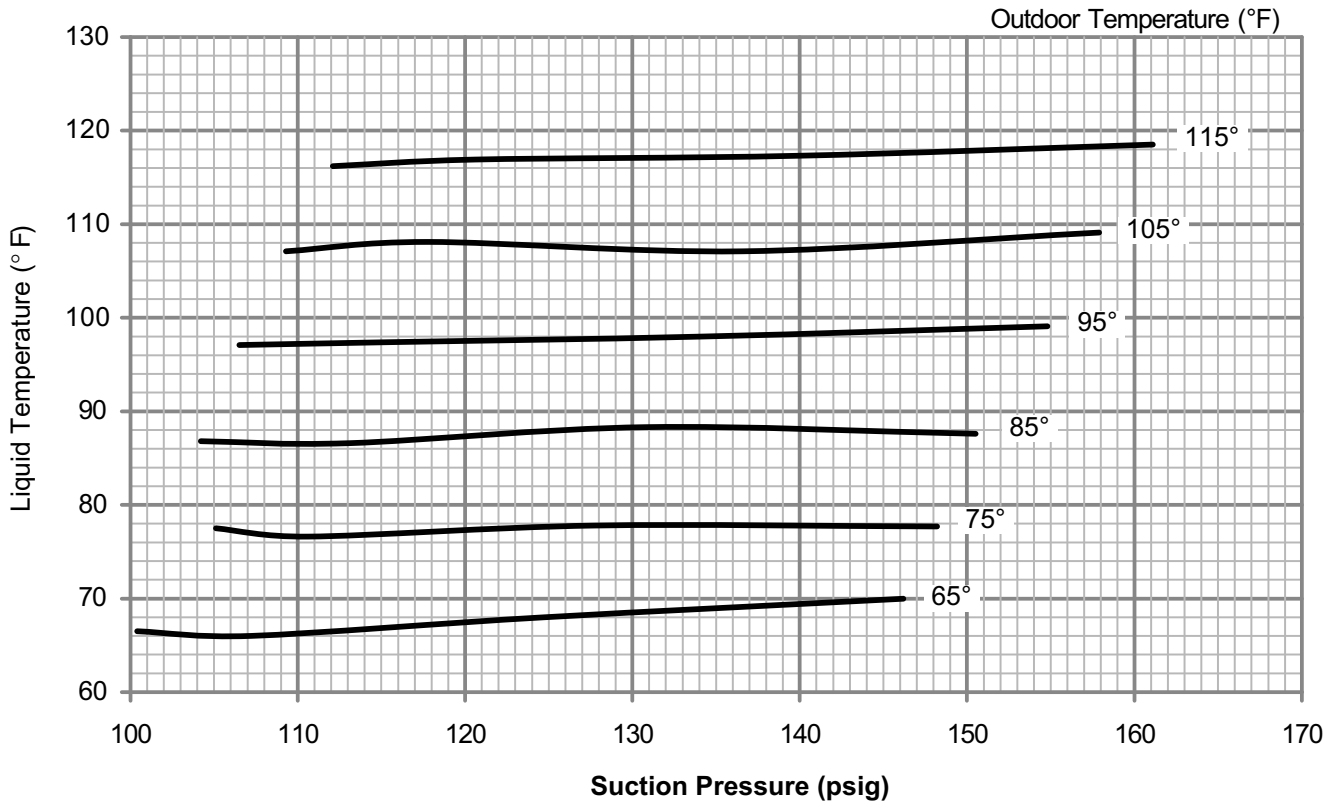

LGH/LCH300H VAV/STAGED SUPPLY AIR Circuit 3 Charging Curve

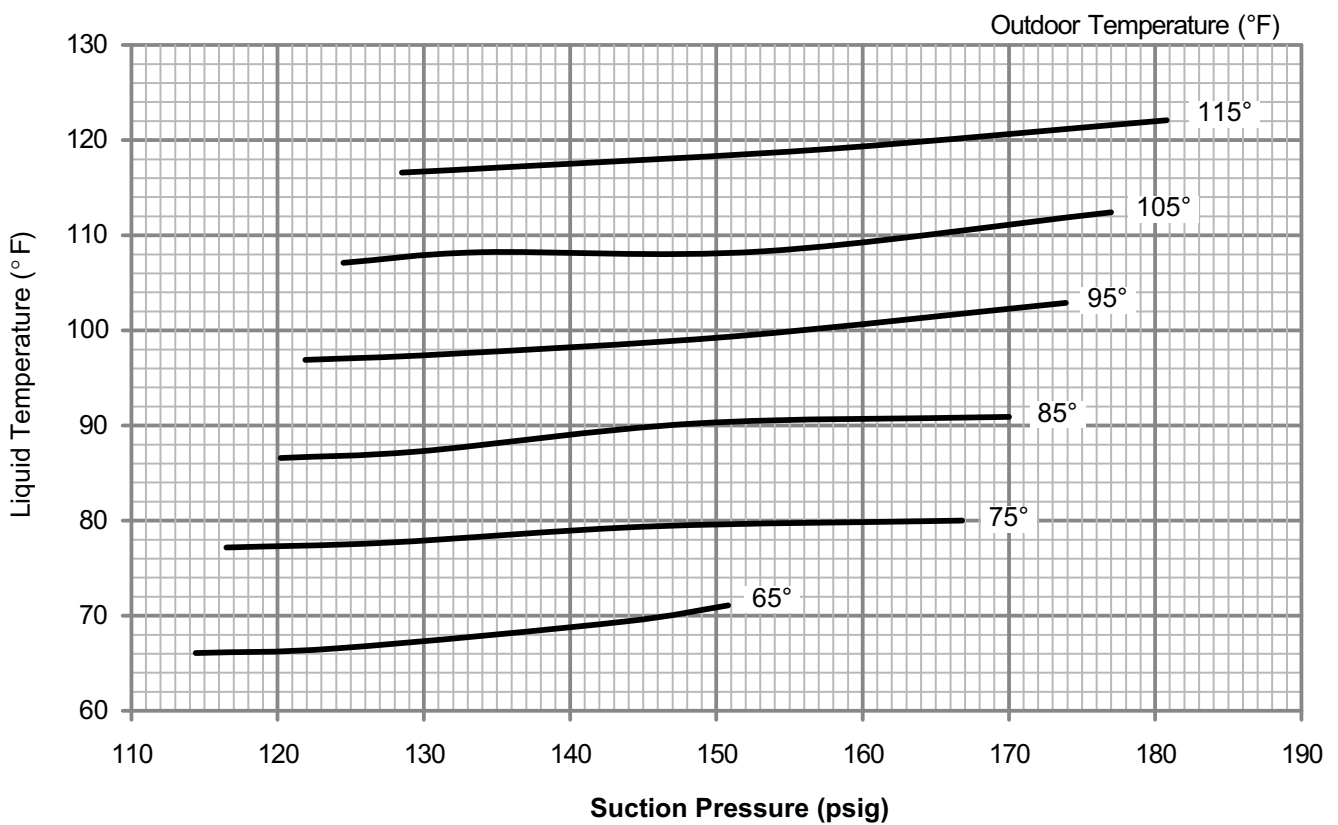

LGH/LCH300H VAV/STAGED SUPPLY AIR Circuit 4 Charging Curve

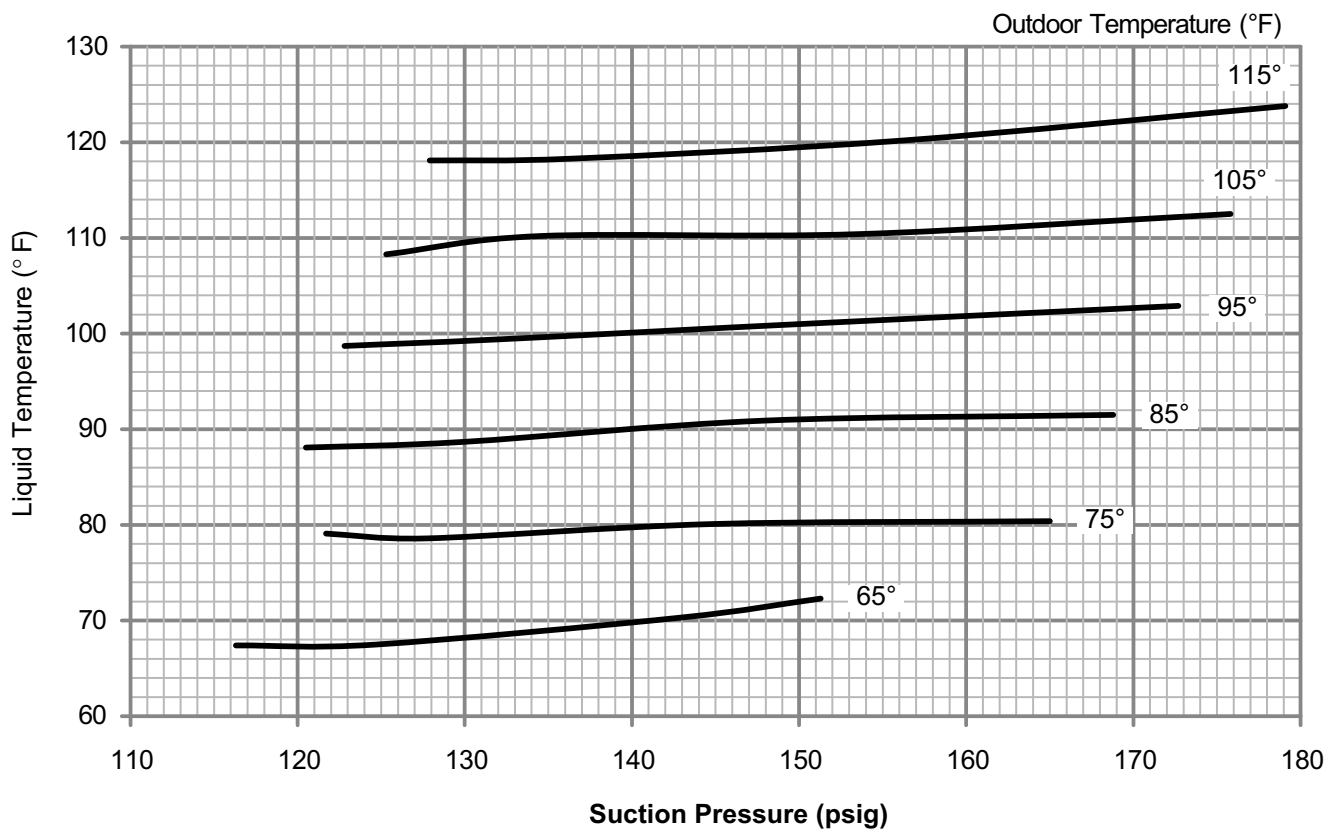

LGH/LCH360 CAV Circuit 1 Charging Curve

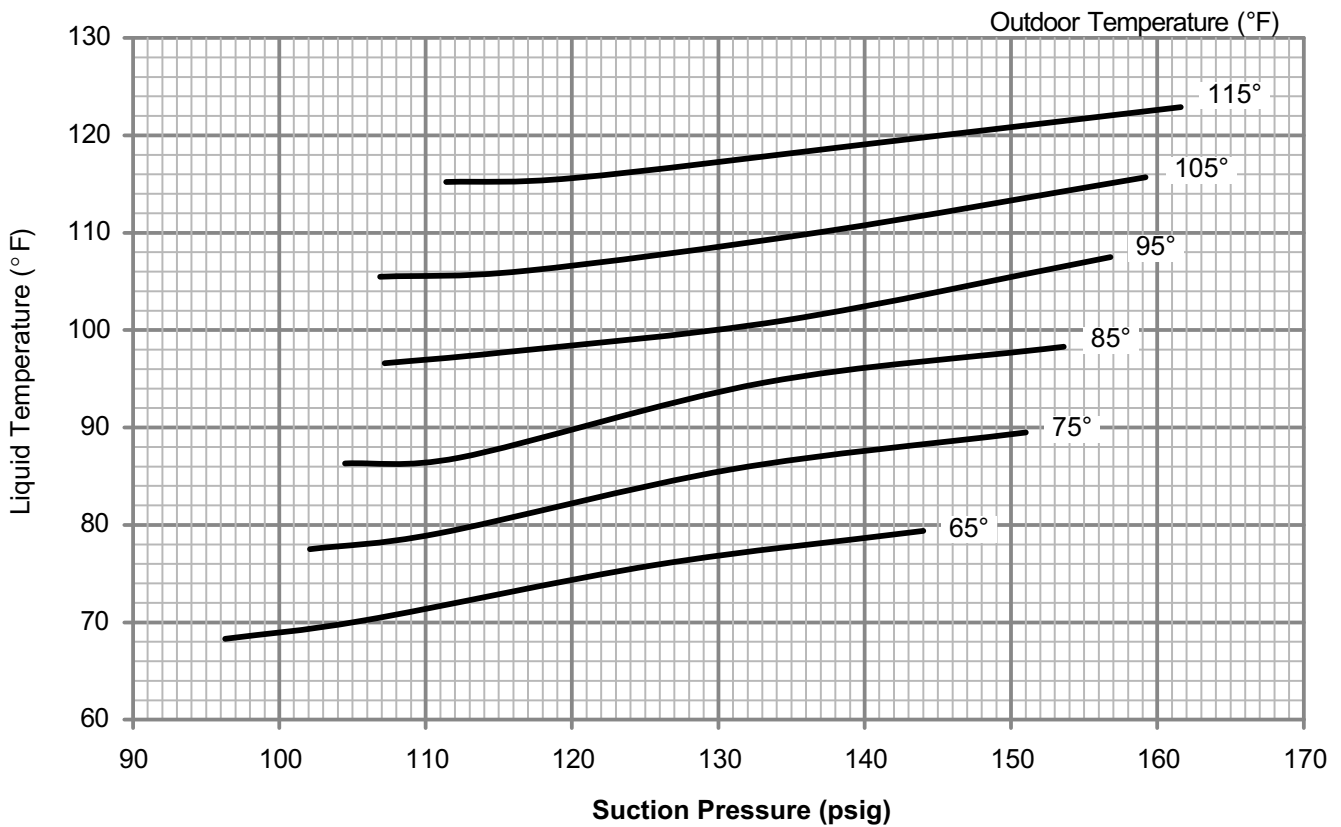

LGH/LCH360 CAV Circuit 2 Charging Curve

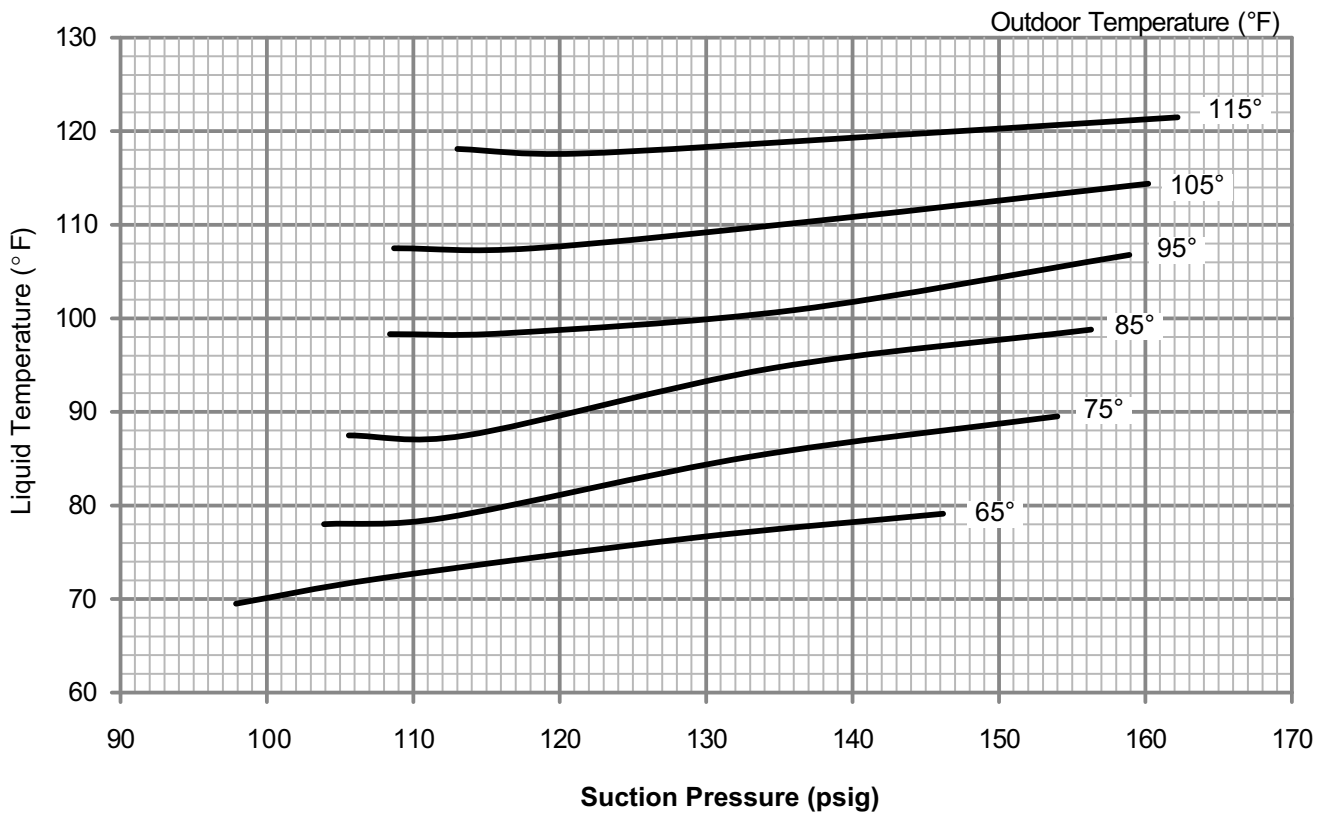

LGH/LCH360 CAV Circuit 3 Charging Curve

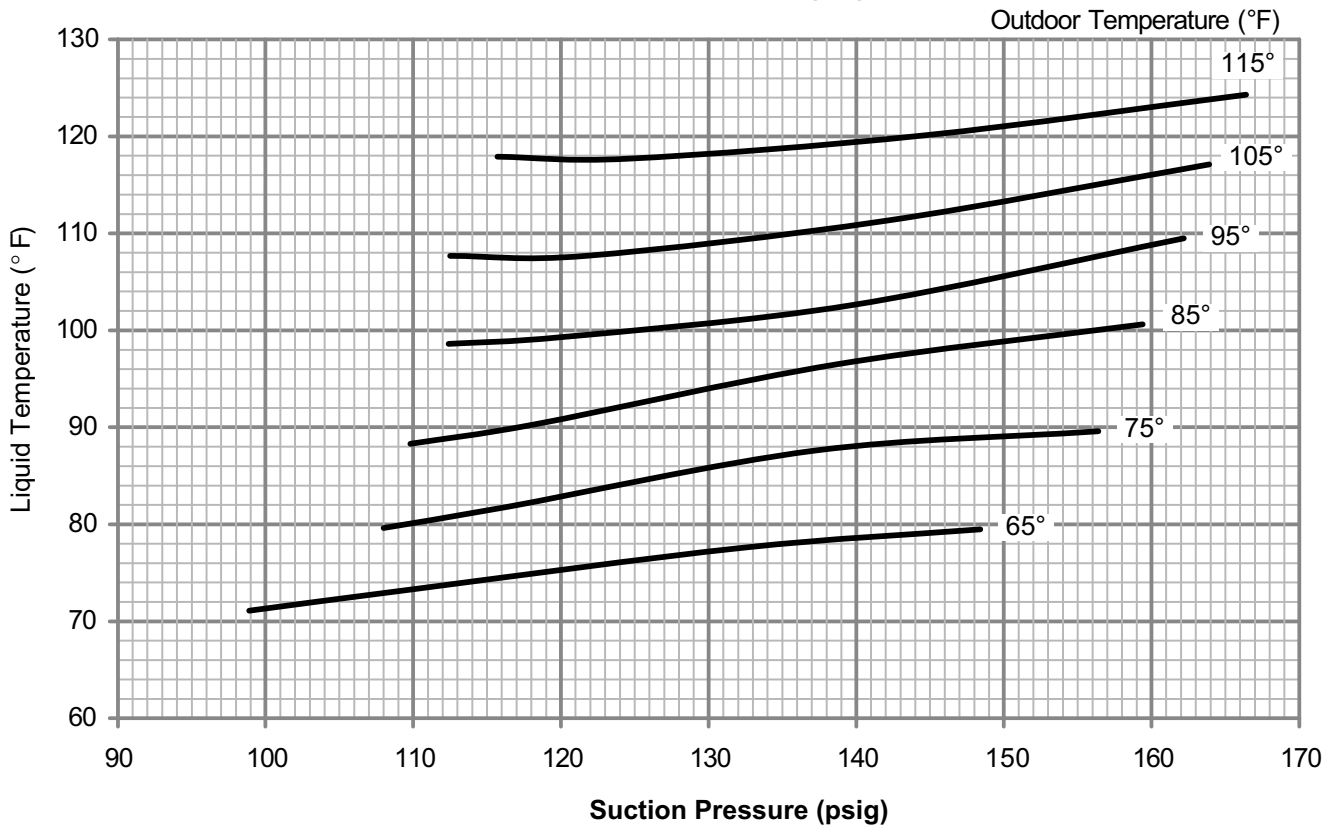

LGH/LCH360 CAV Circuit 4 Charging Curve

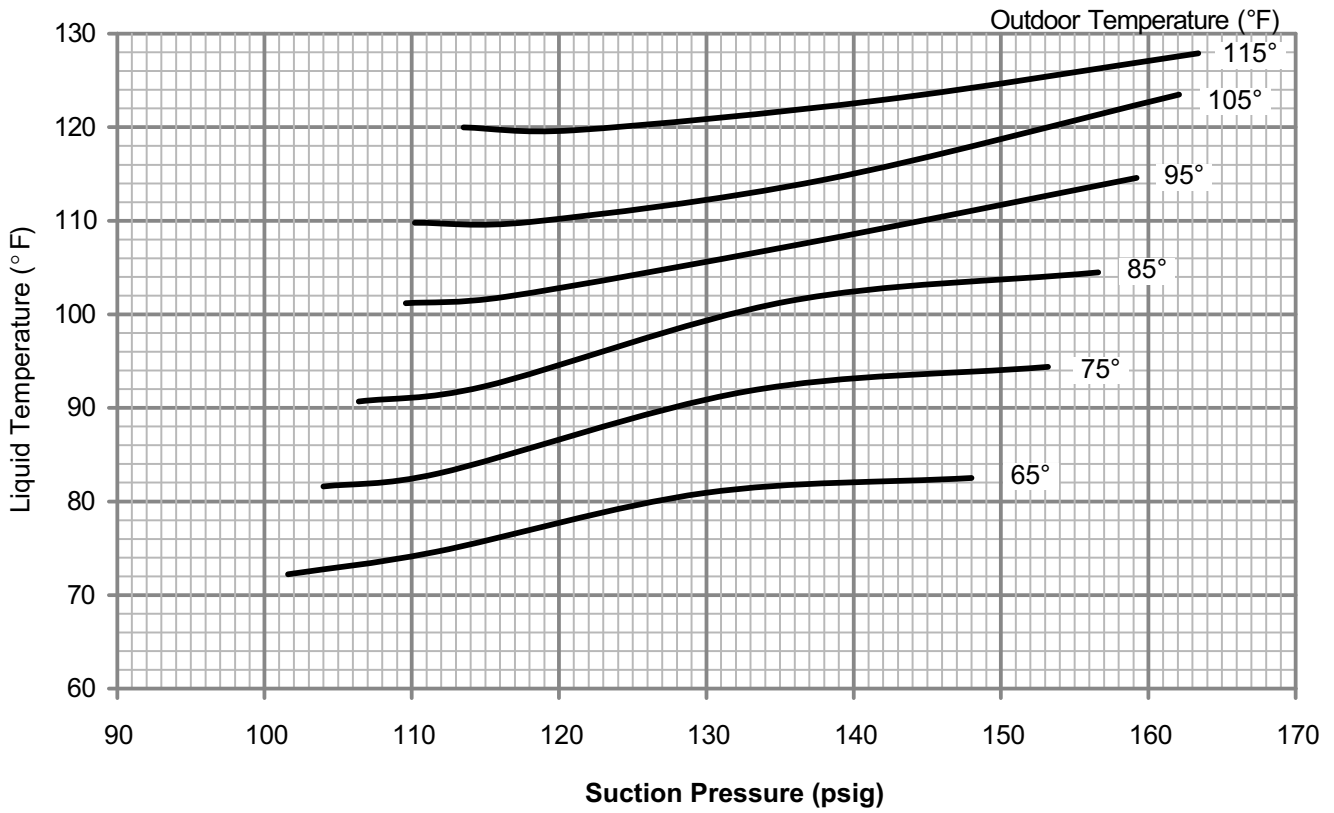

LGH/LCH360 VAV/STAGED SUPPLY AIR Circuit 1 Charging Curve

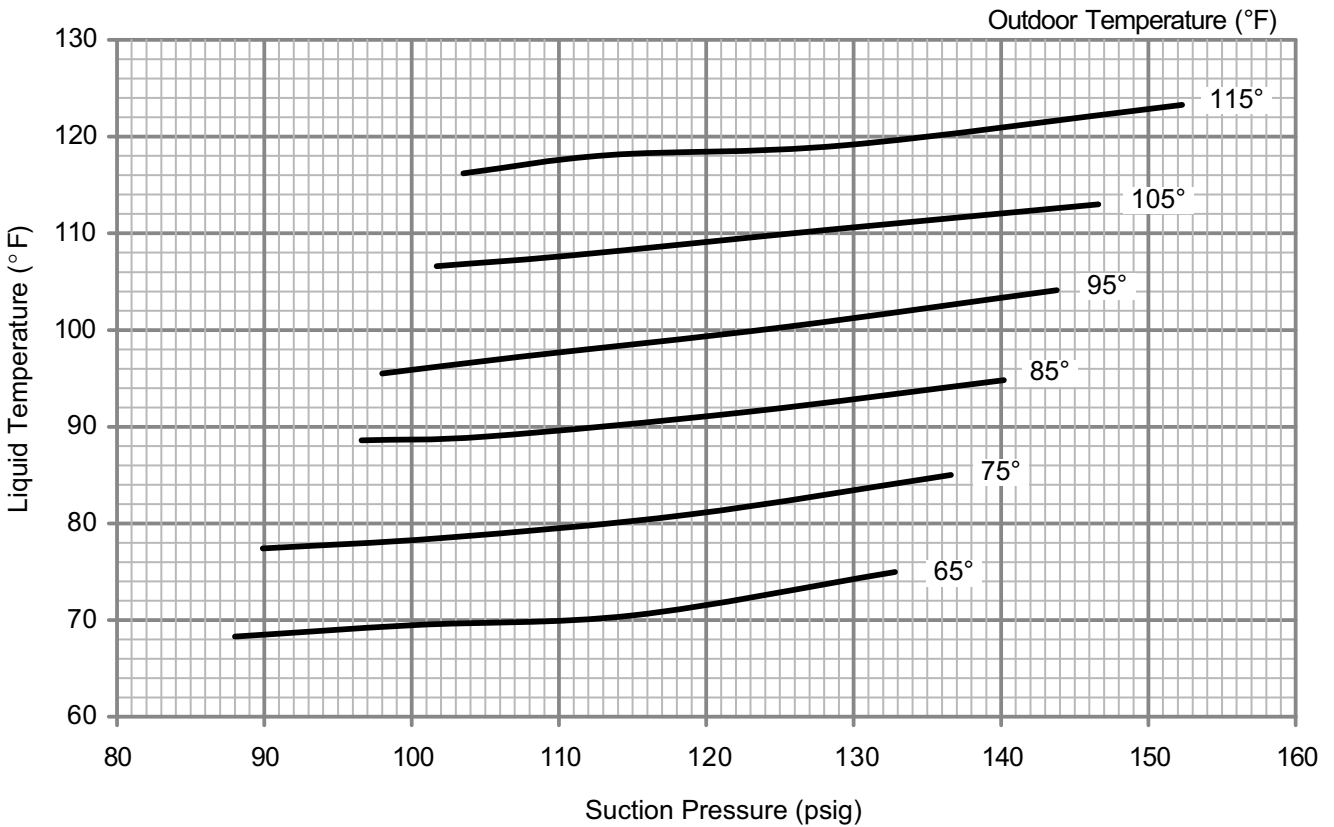

LGH/LCH360 VAV/STAGED SUPPLY AIR Circuit 2 Charging Curve

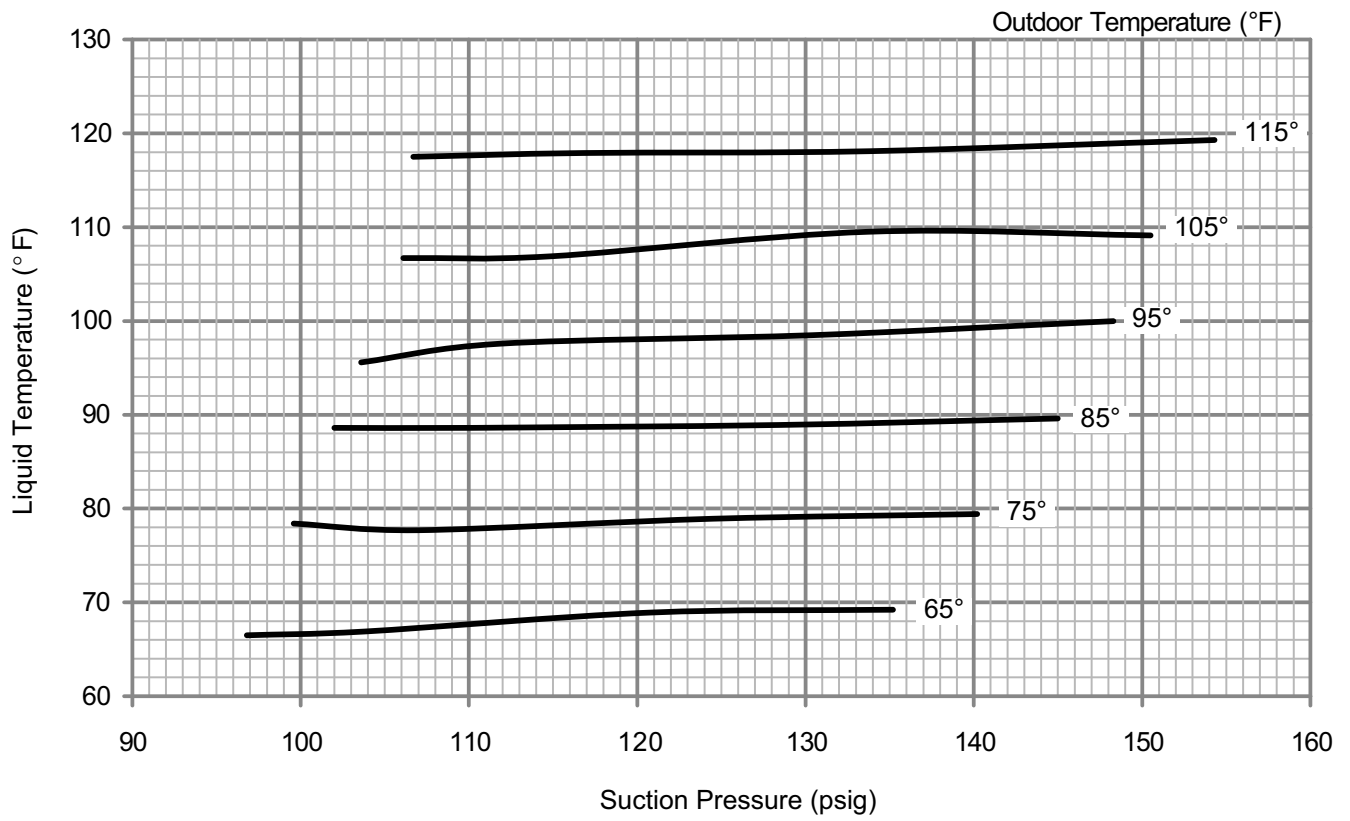

LGH/LCH360 VAV/STAGED SUPPLY AIR Circuit 3 Charging Curve

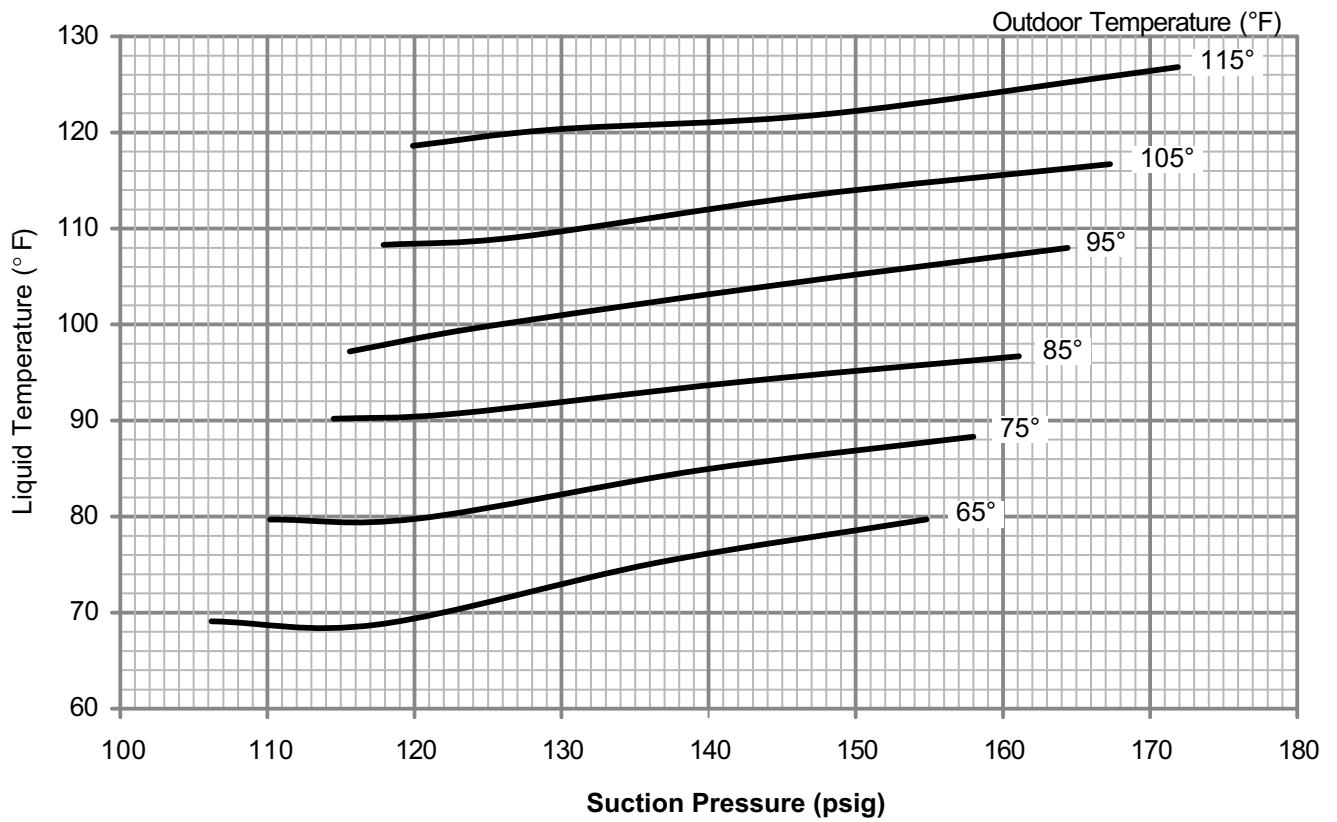

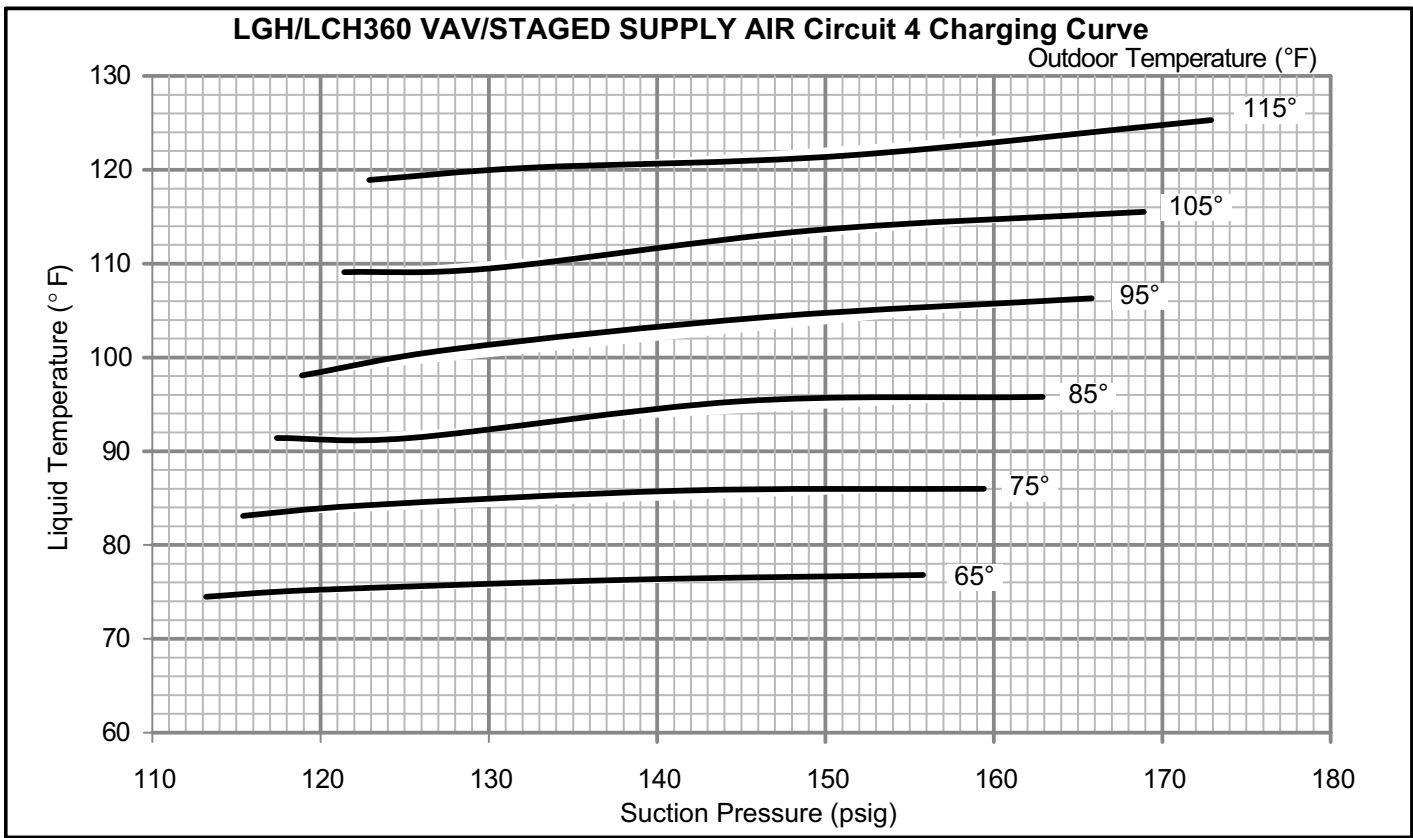

D-Heating Start Up

FOR YOUR SAFETY READ BEFORE LIGHTING

BEFORE LIGHTING smell all around the appliance area for gas. Be sure to smell next to the floor because some gas is heavier than air and will settle on the floor.

Use only your hand to push in or turn the gas control knob. Never use tools. If the knob will not push in or turn by hand, do not try to repair it, call a qualified service technician. Force or attempted repair may result in a fire or explosion.

This unit is equipped with an automatic spark ignition system. There is no pilot. In case of a safety shutdown, move thermostat switch to **OFF** and return the thermostat switch to **HEAT** to reset ignition control.

⚠ WARNING

Electric shock hazard. Can cause injury or death. Before attempting to perform any service or maintenance, turn the electrical power to unit OFF at disconnect switch(es). Unit may have multiple power supplies.

⚠ WARNING

Danger of explosion. Can cause injury or death. Do not attempt to light manually. Unit has a direct spark ignition system.

⚠ WARNING

Danger of explosion. Can cause injury or product or property damage. If overheating occurs or if gas supply fails to shut off, shut off the manual gas valve to the appliance before shutting off electrical supply.

⚠ WARNING

SMOKE POTENTIAL

The heat exchanger in this unit could be a source of smoke on initial firing. Take precautions with respect to building occupants and property. Vent initial supply air outside when possible.

⚠ WARNING

Danger of explosion and fire. Can cause injury or product or property damage. You must follow these instructions exactly.

Placing Unit In Operation

Gas Valve Operation (Figure 30)

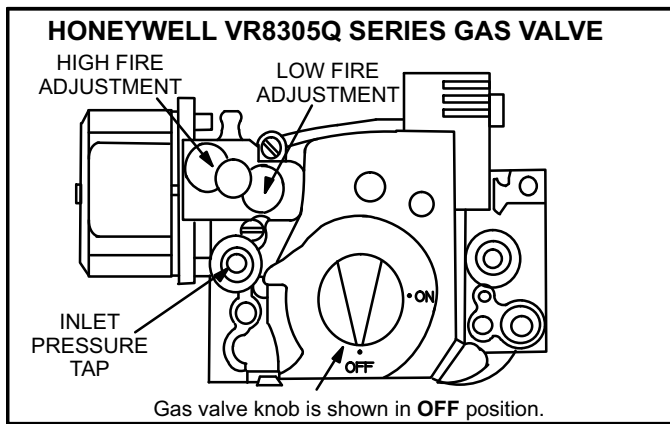

FIGURE 30

- 1- Set thermostat to lowest setting.
- 2- Turn off all electrical power to appliance.
- 3- This appliance is equipped with an ignition device which automatically lights the burner. Do **not** try to light the burner by hand.
- 4- Open or remove the heat section access panel.
- 5- Turn the knob on the gas valve clockwise ➡ to **OFF**. Do not force.
- 6- Wait five minutes to clear out any gas. If you then smell gas, **STOP!** Immediately call your gas supplier from a neighbor's phone. Follow the gas supplier's instructions. If you do not smell gas, go to the next step.
- 7- Turn the knob on the gas valve counterclockwise ⬅ to **ON**. Do not force.
- 8- Close or replace the heat section access panel.
- 9- Turn on all electrical power to unit.
- 10- Set thermostat to desired setting.
- 11- The combustion air inducer will start. The burners will light within 40 seconds.
- 12- If the appliance does not light the first time (gas line not fully purged), it will attempt up to two more ignitions before locking out.
- 13- If lockout occurs, repeat steps 1 through 10.
- 14- If the appliance will not operate, follow the instructions "Turning Off Gas to Appliance" and call your service technician or gas supplier.

Turning Off Gas to Unit

- 1- If using an electromechanical thermostat, set to the lowest setting.
- 2- Before performing any service, turn off all electrical power to the unit.
- 3- Open or remove the heat section access panel.
- 4- Turn the knob on the gas valve clockwise ➡ to **OFF**. Do not force.
- 5- Close or replace the heat section access panel.

E-Safety or Emergency Shutdown

Turn off power to unit.

IV- SYSTEMS SERVICE CHECKS

A-LGH Heating System Service Checks

All LGH units are ETL/CSA design certified without modification.

Before checking piping, check with gas company or authorities having jurisdiction for local code requirements. Refer to the LGH Installation, Operation and Maintenance instruction for more information.

1-Gas Piping

Gas supply piping must not allow more than 0.5"W.C. (124.3 Pa) drop in pressure between the gas meter and the unit. Supply gas pipe must not be smaller than the unit gas connection. Refer to installation instructions for details.

2-Testing Gas Piping

NOTE-In case emergency shutdown is required, turn off the main manual shut-off valve and disconnect the main power to the unit. These controls should be properly labeled by the installer.

When pressure testing gas lines, the gas valve must be disconnected and isolated. Gas valves can be damaged if subjected to more than 0.5 psig [14"W.C. (3481 Pa)]. See figure 31.

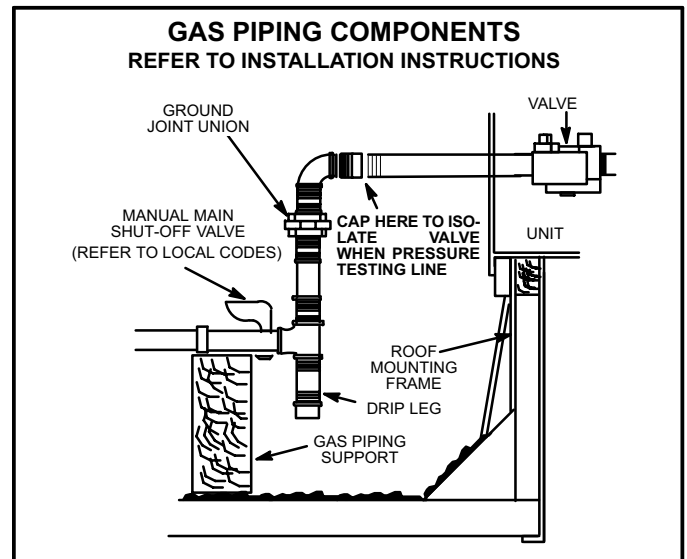

FIGURE 31

When checking piping connection for gas leaks, use the preferred means. Common kitchen detergents can cause harmful corrosion on various metals used in gas piping. The use of specialty Gas Leak Detector is strongly recommended. It is available through Lennox under part number 31B2001. See CORP 8411-L10, for further details.

Do not use matches, candles, flame or any other source of ignition to check for gas leaks.

3-Testing Gas Supply Pressure

When testing gas supply pressure, connect test gauge to the inlet pressure tap on the gas valve (figure 30). Test supply gas pressure with unit firing at maximum rate (both stages energized). Make sure the reading falls within the range of the following values. Low pressure may result in erratic operation or "underfire." High pressure can result in permanent damage to the gas valve or "overfire." For natural gas units, operating pressure at the unit gas connection must be between 4.7"W.C. and 10.5"W.C. (1168 Pa and 2610 Pa). For L.P. gas units, operating pressure at the unit gas connection must be between 10.8"W.C. and 13.0"W.C. (2685 Pa and 3232 Pa).

On multiple unit installations, each unit should be checked separately while operating at maximum rate, beginning with the one closest to the supply gas main and progressing to the one furthest from the main. Multiple units should also be tested with and without the other units operating. Supply pressure must fall within the range listed in the previous paragraph.

4-Check and Adjust Manifold Pressure

After line pressure has been checked and adjusted, check manifold pressure. Move test gauge to the outlet pressure tap located on unit gas valve GV1. See table 5 in GAS HEAT COMPONENT section for proper manifold pressure and figure 30 for location of pressure tap on the gas valve.

The manifold pressure is factory set and should not require adjustment. If manifold pressure is incorrect and no other source of improper manifold pressure can be found, the valve must be replaced. Refer to figure 30 for location of gas valve (manifold pressure) adjustment screw.

All gas valves are factory regulated. The gas valve should completely and immediately cycle off in the event of gas or power failure. The manual shut-off knob can be used to immediately shut off gas supply.

CAUTION

For safety, connect a shut-off valve between the manometer and the gas tap to permit shut off of gas pressure to the manometer.

Manifold Adjustment Procedure

- 1- Connect test gauge to the outlet pressure tap on the gas valve. Start the unit (call for second stage heat) and allow five minutes for the unit to reach steady state.
- 2- While waiting for the unit to stabilize, notice the flame. The flame should be stable without flashback and should not lift from the burner heads. Natural gas should burn basically blue with some clear streaks. L.P. gas should burn mostly blue with some clear yellow streaks.

- 3- After allowing the unit to stabilize for five minutes, record the manifold pressure and compare to the values given for gas supply pressure in table 5.

Combustion gases

Flue products must be analyzed and compared to the unit specifications. Problems detected during the inspection may make it necessary to temporarily shut down the furnace until the items can be repaired or replaced.

CAUTION

Disconnect heating demand as soon as an accurate reading has been obtained.

5-Proper Gas Flow

To check for proper gas flow to burners, determine Btuh input from unit rating plate or the gas heating capacity tables in the SPECIFICATIONS section of this manual. Divide this input rating by the Btuh per cubic foot of available gas. Result is the number of cubic feet per hour required. Determine the flow of gas through gas meter for two minutes and multiply by 30 to get hourly flow of gas to the burners.

NOTE - To obtain accurate reading, shut off all other gas appliances connected to meter.

6-Inshot Burner

Burners are factory set for maximum air and cannot be adjusted. Always operate unit with access panel in place. A peep hole is furnished in the heating access panel for flame viewing. Natural gas should burn basically blue with some clear streaks. L.P. gas should burn mostly blue with some clear yellow streaks.

Figure 32 shows how to remove burner assembly.

- 1- Turn off power to unit and shut off gas supply.
- 2- Remove screws holding the burner support cap.
- 3- Slide each burner off its orifice.
- 4- Clean and reassemble (reverse steps 1-3).
- 5- Be sure to secure all wires and check plumbing.
- 6- Turn on power to unit. Follow lighting instructions attached to unit and operate unit in heating mode. Check burner flames. They should be blue with yellow streaks.

7-Spark Electrode Gap

The spark electrode assembly can be removed for inspection by removing two screws securing the electrode assembly and sliding it out of unit.

For proper unit operation, electrodes must be positioned and gapped correctly.

Spark gap may be checked with appropriately sized twist drills or feeler gauges. Disconnect power to the unit and remove electrode assembly. The gap should be between $0.125" \pm 0.015"$ ($3.2 \text{ mm} \pm .4 \text{ mm}$). See figure 25.

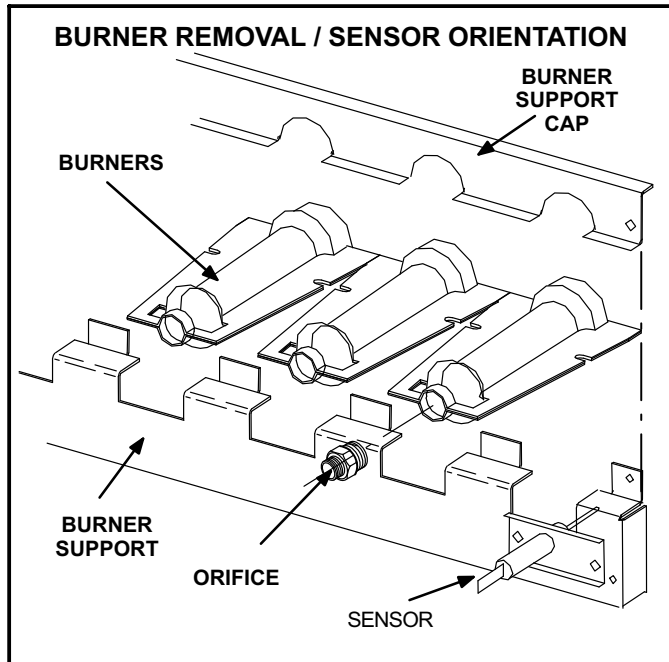

FIGURE 32

8-Heat Exchanger

To Access or Remove Heat Exchanger From Unit:

- 1- Turn off gas and electric power.
- 2- Remove access panel(s) and unit center mullion.
- 3- Remove gas valve, manifold assembly and burners.
- 4- Remove combustion air blower and flue box. Pay careful attention to the order in which gaskets and orifice are removed.
- 5- Support heat exchanger (to prevent it from falling when final screws are removed.)
- 6- Remove screws supporting heat exchanger and slide out.
- 7- To install heat exchanger, reverse procedure. Be sure to secure all wires and check plumbing and burner plate for airtight seal. Screws must be torqued to 35 in.-lbs. (155.7 N) to ensure proper operation.

9-Flame Sensing

Flame current is an electrical current which passes from the ignition control through the sensor electrode during unit operation. The current passes from the sensor through the flame to the ground electrode (located on the flame electrode) to complete a safety circuit. See table 13 for flame

signal range. The electrodes should be located so the tips are at least 1/2" (12.7 mm) inside the flame envelope. Do not bend electrodes. To measure flame current, follow the procedure below:

NOTE-Electrodes are not field adjustable. Any alterations to the electrode may create a hazardous condition that can cause property or personal injury.

- 1- Disconnect power to unit.
- 2- Remove lead from sensing electrode and install a 0-50DC microamp meter in series between the sensing electrode and the sensing lead.
- 3- Reconnect power and adjust thermostat for heating demand.
- 4- When flame is established compare reading to table 13. Do not bend electrodes.
- 5- Disconnect power to unit before disconnecting meter. Make sure sensor wire is securely reconnected before reconnecting power to unit.

TABLE 13

| Manufacturer | Nominal Signal | Drop Out |
|--------------|----------------|----------|
| UTEC | 0.5-1.0 | .09 |
| FENWAL | 1.7-3.6 | 0.7 |

NOTE-If the meter scale reads 0, the leads are reversed. Disconnect power and reconnect leads for proper polarity.

10-Combustion Air Inducer

The combustion air inducer is factory set and is not field adjustable. However, operation should be monitored to ensure proper operation. The combustion air inducer is used to draw fresh air into the combustion chamber while simultaneously expelling exhaust gases. The inducer operates throughout the heating cycle.

On a heating demand, the ignition control is energized by the Unit Controller A55. The ignition control then allows 30 to 40 seconds for the combustion air inducer to vent exhaust gases from the burners. When the combustion air inducer is purging the exhaust gases, the combustion air prove switch is closing proving that the combustion air inducer is operating before allowing the ignition control to energize. When the combustion air prove switch is closed and the delay is over, the ignition control activates the first stage operator of the gas valve (low fire), the spark and the flame sensing electrode. Sparking stops immediately after flame is sensed.

11-High Altitude Derate

Units may be installed at altitudes up to 2000 feet above sea level without any modification.

At altitudes above 2000 feet, units must be derated to match gas manifold pressures shown in table 14.

At altitudes above 4500 feet unit must be derated 2% for each 1000 feet above sea level.

NOTE - This is the only permissible derate for these units.

TABLE 14
HIGH ALTITUDE DERATE - 2000-4500 FT.

| Gas Heat Type | Altitude - ft. | Gas Manifold Pressure - in. w.g. | | Input Rate Natural Gas or LPG / Propane - Btuh | |
|---------------|----------------|----------------------------------|-------------|--|-----------|
| | | Nat-ural | LPG/Propane | 1st Stage | 2nd Stage |
| Std. | 2001 - 4500 | 3.4 | 9.6 | 169,000 | 249,000 |
| Med. | 2001 - 4500 | 3.4 | 9.6 | 234,000 | 345,000 |
| High | 2001 - 4500 | 3.4 | 9.6 | 312,000 | 460,000 |

B-Cooling System Service Checks

All units are factory charged and require no further adjustment; however, charge should be checked periodically using the normal operating pressure method.

1-Gauge Manifold Attachment

Attach high pressure line to discharge line Schrader port and the low pressure line to the suction line Schrader port.

NOTE-When unit is properly charged discharge line pressures should approximate those in Refrigerant Check and Charge section.

V-MAINTENANCE

CAUTION

Electrical shock hazard. Turn off power to unit before performing any maintenance, cleaning or service operation on the unit.

A-Filters

All units are equipped with twelve 20" x 20" x 2" (508mm x 508mm x 51mm) pleated throw-away type filters. Filters may be accessed through the economizer / filter access door (left of the blower door). All filters are removed by pulling on the pull tab, located on the bottom of each row of filters. Filters should be checked monthly (or more frequently in severe use) and cleaned or replaced regularly. Take note of the "AIR FLOW DIRECTION" marking on the filter frame when re-installing.

NOTE-Filters must be U.L.C. certified or equivalent for use in Canada.

CAUTION

Be careful when servicing unit to avoid accidental contact with sharp metallic edges which may cause personal injury.

B-Lubrication

All motors and blower wheels used are prelubricated; no further lubrication is required.

C-Supply Air Blower Wheel

Annually inspect supply air blower wheel for accumulated dirt or dust. Turn off power before attempting to remove access panel or to clean blower wheel. If balancing clips are removed, make sure they are reinstalled in the same location when cleaning is completed.

NOTE-Do not lose balancing clips.

D-Evaporator Coil

Inspect and clean coil at beginning of each season. Clean using mild detergent or commercial coil cleanser. Check condensate drain pan and line, if necessary. Flush coil and condensate drain with water taking care not to get insulation, filters and return air ducts wet. Check connecting lines and coil for evidence of oil and refrigerant leaks.

E-Condenser Coil

Clean condenser coil annually with water and inspect monthly during the cooling season. Access panels are provided on front and back of condenser section.

Clean the all-aluminum coil by spraying the coil steadily and uniformly from top to bottom. Do not exceed 900 psi or a 45° angle; nozzle must be at least 12 inches from the coil face. Take care not to fracture the braze between the fins and refrigerant tubes. Reduce pressure and work cautiously to prevent damage.

NOTE-If owner complains of insufficient cooling, the unit should be gauged and refrigerant charge checked. Refer to Gauge Manifold Attachment and Charging sections in this manual.

F-Electrical

- 1- Check all wiring for loose connections.
- 2- Check for correct voltage at unit (unit operating).
- 3- Check amp-draw on both condenser fan motor and blower motor.

Fan Motor Rating Plate ____ Actual _____

Indoor Blower Motor Rating Plate ____ Actual _____

VI-ACCESSORIES

The accessories section describes the application of most of the optional accessories which can be factory- or field-installed.

A-LARMF18/36-14, 24 or LARMFH30/36-30, 41 Mounting Frames

When installing the LGH/ LCH units on a combustible surface for downflow discharge applications, the Lennox LARMF18/36 14-inch or 24-inch (356 mm or 610mm) height roof mounting frame is used. For horizontal discharge applications, use LARMFH30/36 30-inch or 41-inch (762mm or 1041mm) height roof mounting frame. This frame converts unit from down-flow to horizontal air flow. The 14 and 24 inch (356 and 610mm) downflow and 41 inch (1041mm) horizontal frame meets National Roof-

ing Code requirements. The roof mounting frames are recommended in all other applications but not required. If the units are not mounted on a flat (roof) surface, they MUST be supported under all edges and under the middle of the unit to prevent sagging. The units MUST be mounted level within 1/16" per linear foot or 5mm per meter in any direction.

The assembled LARMF18/36 mounting frame is shown in figure 33. Refer to the roof mounting frame installation instructions for details of proper assembly and mounting. The roof mounting frame MUST be squared to the roof and level before mounting. Plenum system MUST be installed before the unit is set on the mounting frame. Typical roof curbing and flashing is shown in figure 34. Refer to the roof mounting frame installation instructions for proper plenum construction and attachment.

B-Control Systems

The A55 Unit Controller provides all control function for the rooftop unit. Default operation requires a standard room thermostat or direct digital controller (DDC). The A55 can also control the unit from a zone temperature sensor. The A55 Unit Controller is a network controller when daisy-chained to the L Connection® Network Control System. For ease of configuration, the A55 can be connected to a PC with Unit Controller PC software installed.

C-Transitions

Optional supply/return transitions LASRT30/36 are available for use with LGH/LCH series units utilizing optional LARMF18/36 roof mounting frame. Transition must be installed in the LARMF18/36 mounting frame before mounting the unit to the frame. Refer to the manufacturer's instructions included with the transition for detailed installation procedures.

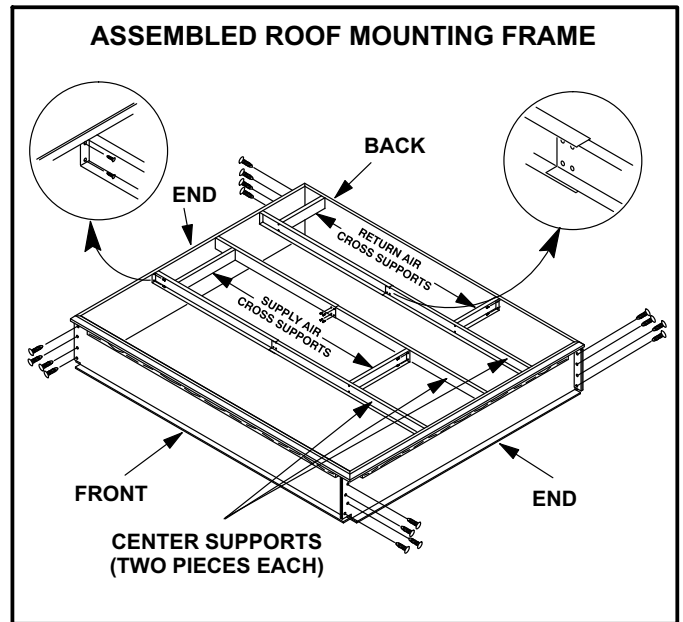

FIGURE 33

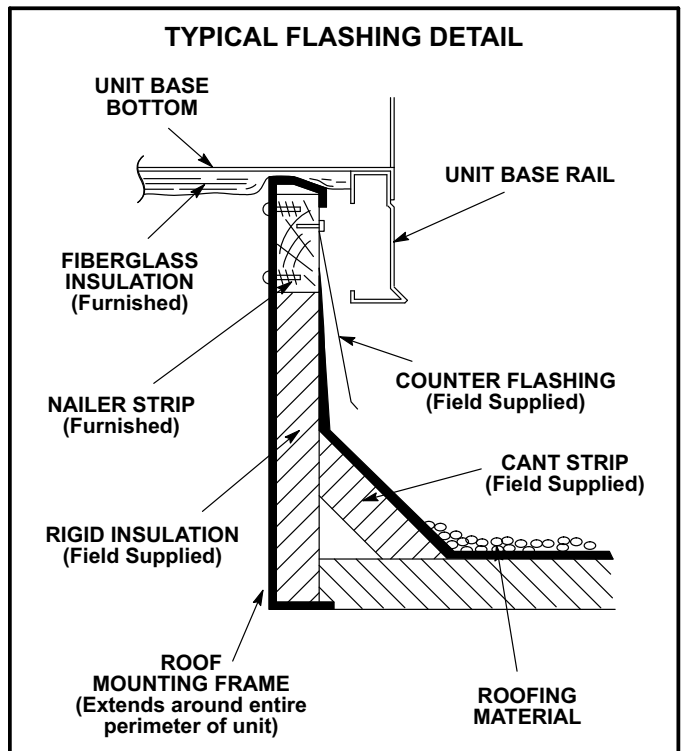

FIGURE 34

D-Supply and Return Diffusers

Optional flush mount diffuser/return FD11 and extended mount diffuser/return RTD11 are available for use with the LGH/LCH units. Refer to manufacturer's instructions included with transition for detailed installation procedures.

E-E1DAMP25D-1 & E1DAMO15D-1 Outdoor Air Dampers

E1DAMP25D-1- & E1DAMO15D-1 consists of a set of dampers which may be manually or motor operated to allow up to 25 percent outside air into the system at all times (see figure 35). Either air damper can be installed in LGH/LCH units. Washable filter supplied with the outdoor air dampers can be cleaned with water and a mild detergent. It should be sprayed with Filter Handicoater when dry prior to reinstallation. Filter Handicoater is R.P. Products coating no. 418 and is available as Lennox Part No. P-8-5069.

F-E1ECON15D-1 Economizer

(Field or Factory Installed)

The optional economizer can be used with LGH/LCH units in downflow and horizontal air discharge applications. The economizer uses outdoor air for free cooling when temperature and/or humidity is suitable. An economizer hood is furnished with the economizer.

NOTE - Gravity exhaust dampers are required with power exhaust.

The economizer is controlled by the A55 Unit Controller.

The economizer will operate in one of four modes. These settings are available through the main menu at SETUP > TEST & BALANCE > DAMPER. Each mode also requires different sensors.

E1DAMP15D-1 MANUAL OUTDOOR AIR DAMPER

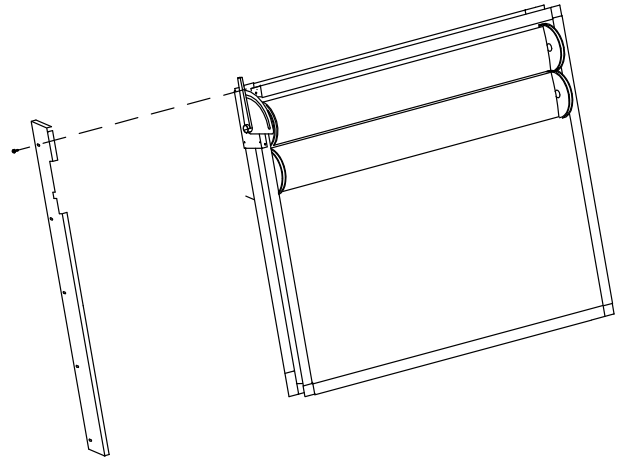

E1DAM025D-1 MOTORIZED OUTDOOR AIR DAMPER

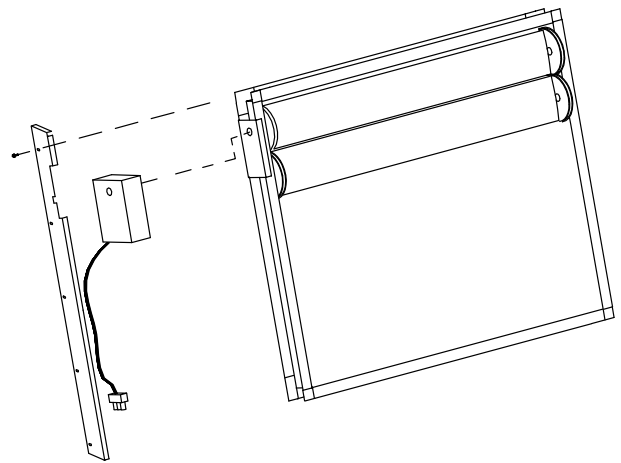

FILTER BRACKET SIDE VIEW

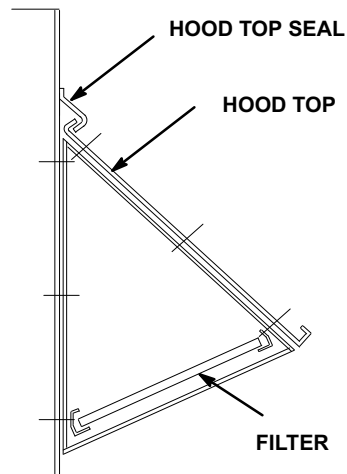

FIGURE 35

1-"TMP" MODE (SENSIBLE TEMPERATURE)

In the "TMP" mode, the A55 Unit Controller uses input from the factory installed RT6 Supply Air Sensor, RT16 Return Air Sensor, and RT17 Outdoor Air Sensor to determine suitability of outside air and economizer damper operation. When outdoor sensible temperature is less than return air sensible temperature, outdoor air is used for cooling. This may be supplemented by mechanical cooling to meet comfort demands. This application does not require additional optional sensors.

2-"ODE" MODE (OUTDOOR ENTHALPY)

The "ODE" or outdoor enthalpy mode requires a factory or field-provided and -installed Honeywell C7400 enthalpy sensor (53W64). The sensor monitors outdoor air temperature and humidity (enthalpy). When outdoor air enthalpy is below the enthalpy control setpoint, the economizer modulates to allow outdoor air for free cooling.

3-"DIF" MODE (DIFFERENTIAL ENTHALPY)

The "DIF" or differential enthalpy mode requires two factory or field-provided and -installed Honeywell C7400 enthalpy sensors (53W64). One sensor is installed in the outside air opening and the other sensor is installed in the return air opening. When the outdoor air enthalpy is below the return air enthalpy, the economizer opens to bring in outdoor air for free cooling.

4-"GLO" MODE (GLOBAL)

Global Mode - The "GLO" or global mode is used with an energy management system which includes a global control feature. Global control is used when multiple units (in one location) respond to a single outdoor air sensor. Each energy management system uses a specific type of outdoor sensor which is installed and wired by the controls contractor.

Motorized Outdoor Air Damper - The "GLO" mode is also used when a motorized outdoor air damper is installed in the system.

NOTE - All economizer modes of operation will modulate dampers to 55° F (13° C) supply air.

G-Gravity Exhaust Dampers

E1DAMP60D-1 dampers are used in downflow and LAGEDH30/36 are used in horizontal air discharge applications. E1DAMP60D-1 dampers are installed in the return air compartment of the unit (see figure 36). LAGEDH30/36 gravity exhaust dampers are installed in the return air plenum. The dampers must be used any time an economizer or power exhaust fans are applied to LGH/LCH series units. An exhaust hood is furnished with any type of gravity exhaust damper.

Gravity exhaust dampers allow exhaust air to be discharged from the system when an economizer and/or power exhaust is operating. Gravity exhaust dampers also prevent outdoor air infiltration during unit off cycle. See installation instructions for more detail. LAGED(H)30/36 dampers are used with LGH/LCH series units. See installation instructions for more detail.

H-LP / Propane Kit

Two natural to LP / propane gas changeover kits are required for gas conversion on LGH units (one for each gas heat section). The kit includes one gas valve, eleven burner orifices and three stickers. For more detail refer to the natural to LP gas changeover kit installation instructions.

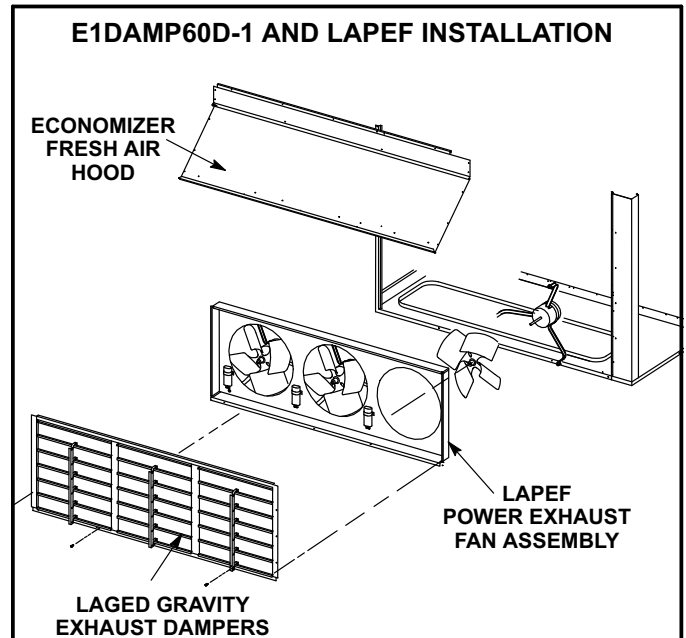

FIGURE 36

I- E1PWRE40D-1 Power Exhaust Fans

Power exhaust fans are used with LGH/LCH in downflow applications only. E1PWRE40D-1 power exhaust fans require optional E1DAMP60D-1 downflow gravity exhaust dampers and E1ECON15D-1 economizer. Power exhaust fans provide exhaust air pressure relief and run when return air dampers are closed and supply air blowers are operating. Figure 36 shows location of the power exhaust fans. See installation instructions for more detail.

J-Smoke Detectors A171, A172, A173

Photoelectric smoke detectors are a factory installed option. The smoke detectors can be installed in the supply air section (A172), return air section (A171), or in both the supply and return air section. Smoke detection control module (A173) is located below the control panel. Wiring for the smoke detectors are shown on the temperature control section (C) wiring diagram in back of this manual.

K-Blower Proving Switch S52

The blower proving switch monitors blower operation and locks out the unit in case of blower failure. The switch is N.O. and closes at 0.15" W.C. (37.4 Pa) The switch is mounted on the middle left corner of the blower support panel. Wiring for the blower proving switch is shown on the temperature control section (C) wiring diagram in back of this manual.

L-Dirty Filter Switch S27

The dirty filter switch senses static pressure increase indicating a dirty filter condition. The switch is N.O. and closes at 0.85" W.C. (211.7 Pa). The switch is mounted on the top corner of the economizer. Wiring for the dirty filter switch is shown on the temperature control section (C) wiring diagram in back of this manual. Actuation of this switch does not affect unit operation.

M-Optional Cold Weather Kit (Canada only)

Electric heater is available to automatically control the minimum temperature in the gas burner compartment. Heater is C.G.A. certified to allow cold weather operation of unit down to -60° F (-50° C).

The kit includes the following parts:

- 1- The strip heater (HR6) is located as close as possible to the gas valve. The strip heater is rated at 500 Watts.
- 2- A thermostat mounting box is installed on the vestibule of the heating compartment. Included in the box are the following thermostat switches:
 - a - Thermostat switch (S59) is an auto-reset SPST N.C. switch which opens on a temperature drop. The switch is wired in series with 24v power and the combustion air blower switch. When the temperature drops below -20° F (-28.9° C) the switch opens and the gas heat section is de-energized. The switch automatically resets when the heating compartment temperature reaches 10° F (-12.2° C).
 - b - Thermostat switch (S60) is an auto-reset SPST N.C. switch which opens on a temperature rise. The switch is wired in series with K125 coil. When the temperature rises above 20° F (-6.7° C) the switch opens and the electric heater is de-energized through K125. The switch automatically resets when the heating compartment temperature reaches -10° F (-23.3° C).
 - c - Thermostat switch (S61) is an auto-reset SPST N.O. switch which closes on a temperature drop. The switch is wired in series with K125 coil. When temperature drops below 20° F (-6.7° C) the switch closes and electric heater is energized through K125. The switch automatically opens when heating compartment temperature reaches 50° F (10° C).

N-Indoor Air Quality (CO₂) Sensor A63

The indoor air quality sensor monitors CO₂ levels and reports the levels to the Unit Controller A55. The board adjusts the economizer dampers according to the CO₂ levels. The sensor is mounted next to the indoor thermostat or in the return air duct. Refer to the indoor air quality sensor installation instructions for proper adjustment. Wiring for the indoor air quality switch is shown on the temperature control section (C) wiring diagram in back of this manual.

O-Supply Air Variable Frequency Drive (VAV units only)

NOTE - Units equipped a Variable Frequency Drive (VFD) are designed to operate on balanced, three-phase power. Operating units on unbalanced three-phase power will reduce the reliability of all electrical components in the unit. Unbalanced power is a result of the power delivery system supplied by the local utility company. Factory-installed inverters are sized to drive blower motors with an equivalent current rating using balanced three-phase power. If unbalanced three-phase power is supplied; the installer must replace the existing factory-installed inverter with an inverter that has a higher current rating to allow for the imbalance. Refer to the installation instructions for additional information and available replacements.

VAV units contain a supply air blower equipped with a variable frequency drive A96 (VFD) which varies supply air CFM. As duct static increases, the supply air volume will decrease. As duct static decreases, the supply air volume will increase.

In VAV units, the Unit Controller uses input from a field-installed pressure transducer (A30) to maintain a 1.0" w.c. (default) static pressure. Refer to the Unit Controller manual parameter 388 and 389 to adjust the static pressure set-point.

The pressure transducer is shipped in a box in the blower compartment. Install the transducer according to manufacturer's instructions.

Note -Make sure the transducer is installed in the main duct at least 2/3 of the distance away from the unit.

The supply air VFD (A96) is located near the compressors. See figure 37.

The Unit Controller will lock-out the unit for 5 minutes (default) if static pressure exceeds 2.0"w.c. for 20 seconds. The Unit Controller will permanently shut down the unit after three occurrences. Use the following parameters to adjust the default values:

Parameter 110; Error time off delay.

Parameter 42; Air Supply Static Shutdown Set Point.

Parameter 43; Static Pressure Lockout Counter Set Point.

VAV By-Pass Operation (Optional)

IMPORTANT - All dampers must be open to prevent damage to duct work and dampers.

- 1- Turn off all power to unit.
- 2- Locate K3, K203, J248 and J249 connectors near the VFD. See figure 41.
- 3- Disconnect J248 from P248 and connect connect P248 jumper plug to J248. P248 jumper plug is attached to the J248 wire harness near the J248 jack connector. See figure 40.
- 4- Disconnect P247 from J247 and connect J249 to P247. See figure 39.

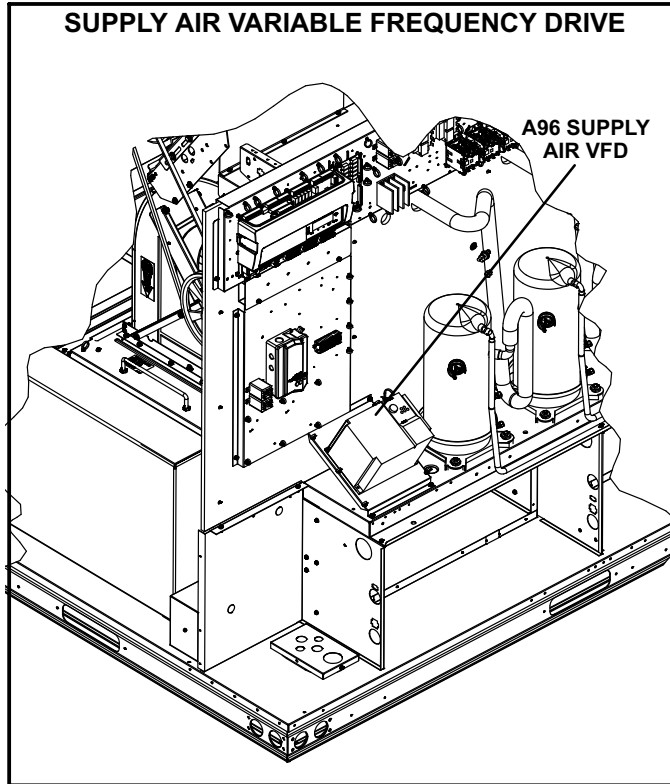

FIGURE 37

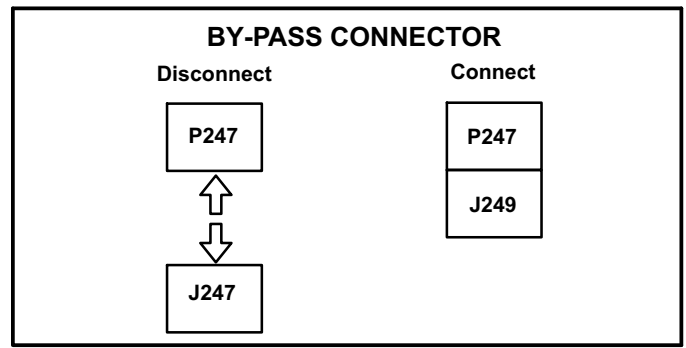

FIGURE 39

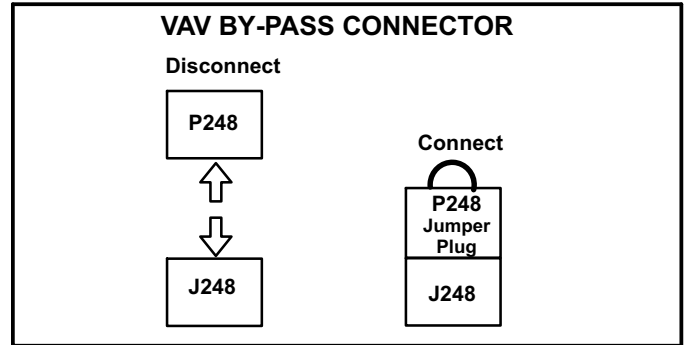

FIGURE 40

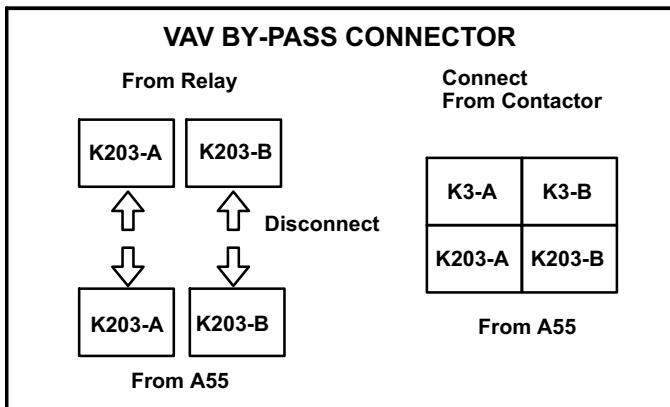

FIGURE 38

- 5- Locate VFD control relay K203 on the lower control panel. See figure 41.
- 6- Disconnect wires marked K203-A and K203-B
- 7- Connect K3-A (female terminal) to K203-A (male terminal) and K3-B (female terminal) to K3-B (male terminal)
- 8- Restore power to unit. Blower will operate in constant air volume (CAV) mode.
- 9- Check the indoor blower motor nameplate for full load amperage (FLA) value. Measure the amp readings from the indoor blower motor operating in bypass mode. If measured amps are higher than nameplate FLA value, decrease the CFM by opening (turning counterclockwise) the motor pulley. Refer to the Indoor Blower Motor section. Do not exceed minimum and maximum number of pulley turns as shown in table 1.

P-Drain Pan Overflow Switch S149 (optional)

The overflow switch is used to interrupt cooling operation when excessive condensate collects in the drain pan. The N.O. overflow switch is controlled by K220 and DL46 relays, located in the unit control panel. When the overflow switch closes, 24VAC power is interrupted and after a five-second delay the unit compressors are de-energized. Once the condensate level drops below the set level, the switch will open. After a five-minute delay the compressor will be energized.

VII-WIRING DIAGRAMS AND OPERATION SEQUENCE

The following pages contain the wiring diagrams for LGH/LCH242/300/360 series units. An economizer and thermostat are also shown. Each wiring diagram is followed by a sequence of operation.

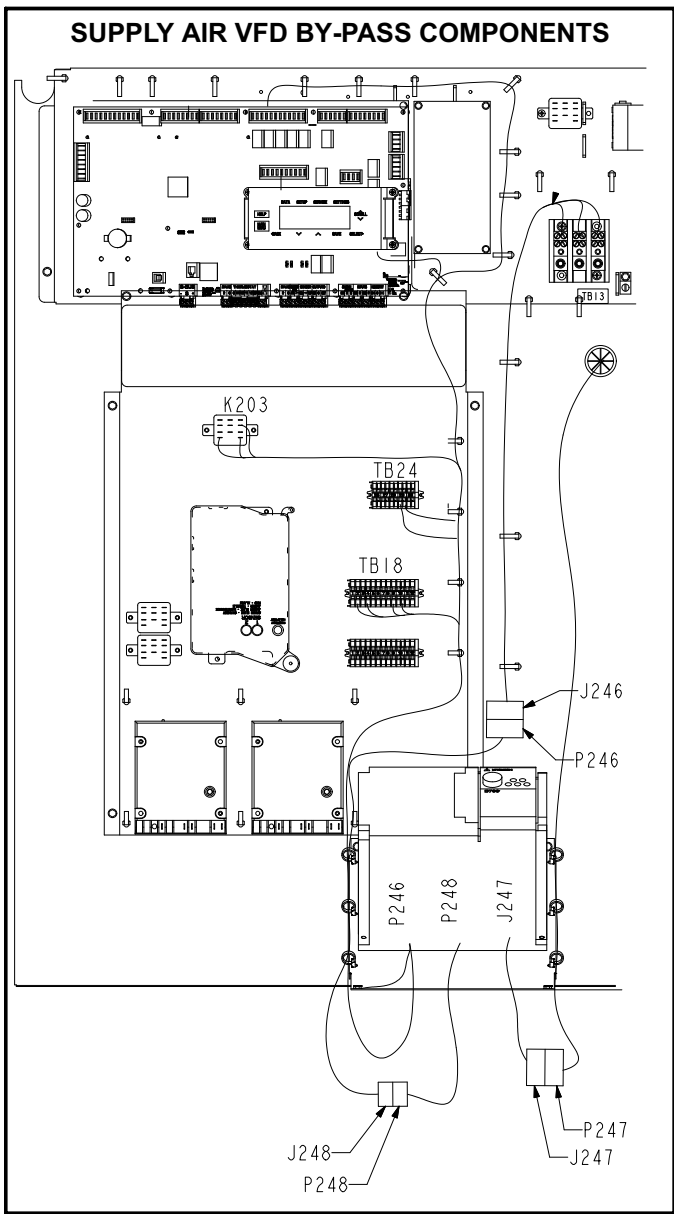

FIGURE 41

| KEY | |
|------|---|
| A55 | CONTROL BOARD, MAIN |
| A178 | CONTROL BOARD, COMP 3 & 4, 2ND STAGE HEAT |
| B1 | COMPRESSOR 1 |
| B2 | COMPRESSOR 2 |
| B3 | MOTOR, BLOWER |
| B4 | MOTOR, OUTDOOR FAN 1 |
| B5 | MOTOR, OUTDOOR FAN 2 |
| B10 | MOTOR, EXHAUST FAN 1 |
| B11 | MOTOR, EXHAUST FAN 2 |
| B12 | MOTOR, EXHAUST FAN 3 |
| B13 | COMPRESSOR 3 |
| B20 | COMPRESSOR 4 |
| B21 | MOTOR, OUTDOOR FAN 3 |
| B22 | MOTOR, OUTDOOR FAN 4 |
| B23 | MOTOR, OUTDOOR FAN 5 |
| B24 | MOTOR, OUTDOOR FAN 6 |
| B35 | MOTOR, EXH. BLO 1 |
| B36 | MOTOR, EXH. BLO 2 |
| B37 | MOTOR, EXH. BLO 3 |
| C1 | CAPACITOR, OUTDOOR FAN 1 |
| C2 | CAPACITOR, OUTDOOR FAN 2 |
| C6 | CAPACITOR, EXHAUST FAN 1 |
| C8 | CAPACITOR, EXHAUST FAN 2 |
| C9 | CAPACITOR, EXHAUST FAN 3 |
| C18 | CAPACITOR, OUTDOOR FAN 3 |
| C19 | CAPACITOR, OUTDOOR FAN 4 |
| C20 | CAPACITOR, OUTDOOR FAN 5 |
| C21 | CAPACITOR, OUTDOOR FAN 6 |
| CB8 | CIRCUIT, BREAKER T1 |
| CB10 | CIRCUIT BREAKER, MAIN DISCONNECT UNIT |
| CB18 | CIRCUIT, BREAKER T18 |
| F6 | FUSE, EXHAUST FAN |
| F10 | FUSE, OUTDOOR FAN MOTOR |
| F30 | FUSE, TRANSFORMER T29 PRIMARY |
| F31 | FUSE, TRANSFORMER T29 SECONDARY |
| F36 | FUSE, INVERTER |

| | |
|------|---------------------------------------|
| HR1 | HEATER COMPRESSOR 1 |
| HR2 | HEATER COMPRESSOR 2 |
| HR5 | HEATER COMPRESSOR 3 |
| HR11 | HEATER COMPRESSOR 4 |
| K1 | CONTACTOR, COMPRESSOR 1 |
| K2 | CONTACTOR, COMPRESSOR 2 |
| K3 | CONTACTOR, BLOWER |
| K10 | RELAY, OUTDOOR FAN 1 |
| K14 | CONTACTOR, COMPRESSOR 3 |
| K65 | RELAY, EXHAUST FAN |
| K68 | RELAY, OUTDOOR FAN 2 |
| K146 | CONTACTOR, COMPRESSOR 4 |
| K149 | RELAY, OUTDOOR FAN 3 |
| K150 | RELAY, OUTDOOR FAN 4 |
| K152 | RELAY, OUTDOOR FAN 5 |
| K153 | RELAY, OUTDOOR FAN 6 |
| K205 | CONTACTOR, P.E. BLOWER |
| RT17 | SENSOR, OUTDOOR AIR |
| S4 | SWITCH, LIMIT HI PRESS COMPRESS 1 |
| S7 | SWITCH, LIMIT HI PRESS COMPRESS 2 |
| S11 | SWITCH, LOW PRESS, LOW AMBIENT COMP 1 |
| S28 | SWITCH, LIMIT HI PRESS COMPRESS 3 |
| S42 | SWITCH, OVERLOAD RELAY BLOWER MOTOR |
| S48 | SWITCH, DISCONNECT |
| S49 | SWITCH, FREEZE STAT COMPRESS 1 |
| S50 | SWITCH, FREEZE STAT COMPRESS 2 |
| S53 | SWITCH, FREEZE STAT COMPRESS 3 |
| S84 | SWITCH, LOW PRESS, LOW AMBIENT COMP 2 |
| S85 | SWITCH, LOW PRESS, LOW AMBIENT COMP 3 |
| S87 | SWITCH, LOW PRESS, COMP 1 |
| S88 | SWITCH, LOW PRESS, COMP 2 |
| S94 | SWITCH, LOW PRESS, LOW AMBIENT COMP 4 |
| S95 | SWITCH, FREEZE STAT COMPRESS 4 |
| S96 | SWITCH, LIMIT HI PRESS COMPRESS 4 |
| S97 | SWITCH, LOW PRESS, COMP 4 |
| S98 | SWITCH, LOW PRESS, COMP 3 |
| S117 | SWITCH, GFI |
| T1 | TRANSFORMER, CONTROL |
| T18 | TRANSFORMER, CONTACTOR |
| T29 | TRANSFORMER, GFI |
| TB13 | TERMINAL BLOCK, POWER DISTRIBUTION |
| TB24 | TERMINAL STRIP, UNIT ADDER |
| TB58 | TERMINAL BLOCK, EXHAUST BLOWERS |

| J/P | JACK/PLUG DESCRIPTION |
|-----|--------------------------------|
| 11 | GFI, RECEPTACLE |
| 18 | EXHAUST FAN COMP |
| 24 | EXHAUST FAN |
| 69 | INTERFACE, POWER EXHAUST |
| 86 | OUTDOOR FAN INTERFACE |
| 87 | OUTDOOR FAN INTERFACE 2 |
| 118 | COMPRESSOR 3 AND 4, CONTROL |
| 119 | COMPRESSOR 3 AND 4, INPUT |
| 132 | EXHAUST FAN MOTOR 1 |
| 133 | EXHAUST FAN MOTOR 2 |
| 134 | EXHAUST FAN MOTOR 3 |
| 208 | MOTOR, EXH BLO, B35 |
| 209 | MOTOR, EXH BLO, B36 |
| 210 | MOTOR, EXH BLO, B37 |
| 212 | MOTOR, EXH BLO B35 |
| 213 | MOTOR, EXH BLO B36 |
| 214 | MOTOR, EXH BLO B37 |
| 218 | POWER EXHAUST CONTROL |
| 263 | HIGH AND LOW PRESSURE SWITCHES |
| 264 | BLOWER DECK |
| 265 | CONTACTORS AND RELAYS |
| 267 | OUTDOOR FAN AREA |
| 268 | 24V POWER FROM TRANSFORMER |

NOTE - IF ANY WIRE IN THIS APPLIANCE IS REPLACED IT MUST BE REPLACED WITH WIRE OF LIKE SIZE, RATING, TERMINATION AND INSULATION THICKNESS.

WARNING - ELECTRICAL SHOCK HAZARD, CAN CAUSE INJURY OR DEATH. UNIT MUST BE GROUNDED IN ACCORDANCE WITH NATIONAL AND LOCAL CODES. DISCONNECT ALL POWER BEFORE SERVICING.

△ S42 USED ON "M" VOLTAGE UNITS AND UNITS WITH HIGH EFFICIENCY MOTORS AND MOTORS LESS INTERNAL OVERLOAD PROTECTION

△ F6 AND F10 FUSES ARE USED ON

△ S49, S50, S53 AND S95 ARE PART OF 5VDC CIRCUIT

△ K205 AND P218 ARE A PART OF RRS ASSEMBLY

△ B37 BLOWER MAY NOT BE USED

← DENOTES OPTIONAL COMPONENTS
 — LINE VOLTAGE FIELD INSTALLED

| | | | |
|--|---|--|-------|
| 08/17 |  | ENERGENCE WIRING DIAGRAM 537881-01 | 08/17 |
| COOLING LCH/LGH - 300,360 - G,J,M,Y (CAV) | | | |
| Supersedes | | New Form No. | |
| 537369-01 | | 537881-01 | |

**LGH/LCH242, 300, 360 G, J, Y
WITH VFD CONTROL**

| KEY | COMPONENT |
|------|---|
| A30 | DUCT STATIC PRESS |
| A34 | DIFFERENTIAL PRESSURE TRANSDUCER |
| A55 | CONTROL BOARD, MAIN |
| A96 | CONTROL INVERTER |
| A137 | INVERTER, EXHAUST 1 |
| A141 | INVERTER, EXHAUST 2 |
| A142 | INVERTER, EXHAUST 3 |
| A178 | CONTROL BOARD, COMP 3 & 4, 2ND STAGE HEAT |
| A187 | CONTROL, GENERAL PURPOSE GP3 |
| B1 | COMPRESSOR 1 |
| B2 | COMPRESSOR 2 |
| B3 | MOTOR, BLOWER |
| B4 | MOTOR, OUTDOOR FAN 1 |
| B5 | MOTOR, OUTDOOR FAN 2 |
| B10 | MOTOR, EXHAUST FAN 1 |
| B11 | MOTOR, EXHAUST FAN 2 |
| B12 | MOTOR, EXHAUST FAN 3 |
| B13 | COMPRESSOR 3 |
| B20 | COMPRESSOR 4 |
| B21 | MOTOR, OUTDOOR FAN 3 |
| B22 | MOTOR, OUTDOOR FAN 4 |
| B23 | MOTOR, OUTDOOR FAN 5 |
| B24 | MOTOR, OUTDOOR FAN 6 |
| B35 | MOTOR, EXH, BLO 1 |
| B36 | MOTOR, EXH, BLO 2 |
| B37 | MOTOR, EXH, BLO 3 |
| C1 | CAPACITOR, OUTDOOR FAN 1 |
| C2 | CAPACITOR, OUTDOOR FAN 2 |
| C6 | CAPACITOR, EXHAUST FAN 1 |
| C8 | CAPACITOR, EXHAUST FAN 2 |
| C9 | CAPACITOR, EXHAUST FAN 3 |
| C18 | CAPACITOR, OUTDOOR FAN 3 |
| C19 | CAPACITOR, OUTDOOR FAN 4 |
| C20 | CAPACITOR, OUTDOOR FAN 5 |
| C21 | CAPACITOR, OUTDOOR FAN 6 |
| CB8 | CIRCUIT BREAKER T1 |
| CB10 | CIRCUIT BREAKER, MAIN DISCONNECT UNIT |
| CB18 | CIRCUIT BREAKER T18 |
| F6 | FUSE, EXHAUST FAN |
| F10 | FUSE, OUTDOOR FAN MOTOR |
| F30 | FUSE, TRANSFORMER T29 PRIMARY |
| F31 | FUSE, TRANSFORMER T29 SECONDARY |
| F36 | FUSE, P.E. BLOWERS |
| HR1 | HEATER COMPRESSOR 1 |
| HR2 | HEATER COMPRESSOR 2 |
| HR5 | HEATER COMPRESSOR 3 |
| HR11 | HEATER COMPRESSOR 4 |

| | |
|------|---|
| K1 | CONTACTOR, COMPRESSOR 1 |
| K2 | CONTACTOR, COMPRESSOR 2 |
| K3 | CONTACTOR, BLOWER |
| K10 | RELAY, OUTDOOR FAN 1 |
| K14 | CONTACTOR, COMPRESSOR 3 |
| K65 | RELAY, EXHAUST FAN |
| K68 | RELAY, OUTDOOR FAN 2 |
| K146 | CONTACTOR, COMPRESSOR 4 |
| K149 | RELAY, OUTDOOR FAN 3 |
| K150 | RELAY, OUTDOOR FAN 4 |
| K152 | RELAY, OUTDOOR FAN 5 |
| K153 | RELAY, OUTDOOR FAN 6 |
| K203 | RELAY INVERTER CONTROL |
| K205 | CONTACTOR, POWER EXHAUST |
| K207 | RELAY, EXHAUST BLOWER |
| K231 | SENSOR, OUTDOOR AIR |
| R55 | RESISTOR, VFD LOADING, A96 |
| RT17 | RELAY, EXHAUST FAN 2 |
| S4 | SWITCH, LIMIT HI PRESS COMPRESS 1 |
| S5 | SWITCH, LIMIT HI TEMP COMPRESSOR 1 |
| S7 | SWITCH, LIMIT HI PRESS COMPRESS 2 |
| S8 | SWITCH, LIMIT HI TEMP COMPRESSOR 2 |
| S11 | SWITCH, LOW PRESS, LOW AMBIENT COMP 1 |
| S28 | SWITCH, LIMIT HI PRESS COMPRESS 3 |
| S31 | SWITCH, LIMIT HI TEMP COMPRESSOR 3 |
| S37 | SWITCH, PRESS, EXH |
| S39 | SWITCH, EXHAUST FAN |
| S42 | SWITCH, OVERLOAD RELAY BLOWER MOTOR |
| S48 | SWITCH, DISCONNECT |
| S49 | SWITCH, FREEZE STAT COMPRESS 1 |
| S50 | SWITCH, FREEZE STAT COMPRESS 2 |
| S53 | SWITCH, FREEZE STAT COMPRESS 3 |
| S84 | SWITCH, LOW PRESS, LOW AMBIENT COMP 2 |
| S85 | SWITCH, LOW PRESS, LOW AMBIENT COMP 3 |
| S87 | SWITCH, LOW PRESS, COMP 1 |
| S88 | SWITCH, LOW PRESS, COMP 2 |
| S94 | SWITCH, LOW PRESS, LOW AMBIENT KIT COMP 4 |
| S95 | SWITCH, FREEZE STAT COMPRESS 4 |
| S96 | SWITCH, LIMIT HI PRESS COMPRESS 4 |
| S97 | SWITCH, LOW PRESS, COMP 4 |
| S98 | SWITCH, LOW PRESS, COMP 3 |
| S117 | SWITCH, GFI |

| J/P | JACK/PLUG DESCRIPTION |
|-----|--------------------------------|
| 11 | GFI, RECEPTACLE |
| 18 | EXHAUST FAN COMP |
| 24 | EXHAUST FAN |
| 69 | INTERFACE |
| 86 | OUTDOOR FAN INTERFACE |
| 87 | OUTDOOR FAN INTERFACE 2 |
| 118 | CONTROL FOR COMPRESSOR 3 AND 4 |
| 119 | COMPRESSOR 3 AND 4, INPUT |
| 132 | EXHAUST FAN MOTOR 1 |
| 133 | EXHAUST FAN MOTOR 2 |
| 134 | EXHAUST FAN MOTOR 3 |
| 208 | MOTOR, EXH BLO, B35 |
| 209 | MOTOR, EXH BLO, B36 |
| 210 | MOTOR, EXH BLO, B37 |
| 212 | MOTOR, EXH BLO, B35 |
| 213 | MOTOR, EXH BLO, B36 |
| 214 | MOTOR, EXH BLO, B37 |
| 218 | POWER EXHAUST CONTROL |
| 246 | POWER TO VFD |
| 247 | VFD TO MOTOR |
| 248 | VFD TO CONTROL |
| 249 | CONTACTOR BYPASS |
| 259 | BLOWER ECM MOTOR |
| 263 | HIGH AND LOW PRESSURE SWITCHES |
| 264 | BLOWER DECK |
| 265 | CONTACTORS AND RELAYS |
| 267 | OUTDOOR FAN AREA |
| 268 | 24V POWER FROM TRANSFORMERS |
| 348 | CONTROL, GENERAL PURPOSE GP3 |

NOTES

- ⚠ S42 USED ON UNITS WITH VFD CONTROL WITH BYPASS OPTION, UNITS WITH HIGH EFFICIENCY MOTORS AND UNITS WITH MOTORS LESS INTERNAL OVERLOAD PROTECTION
- ⚠ USED ONLY ON 242 UNITS WITH INTERLINK COMPRESSORS
- ⚠ F6 AND F10 FUSES ARE USED ON "Y" VOLTAGE UNITS ONLY
- ⚠ S49,S50,S53 AND S95 ARE A PART OF 5VDC CIRCUIT
- ⚠ FOR P.E. INVERTER WIRING, REFER TO RRS ASSEMBLY
- ⚠ A30 SENSOR AND A96
- ⚠ A34 SENSOR AND A137, A141, A142 INVERTER CONTROL FOR B35, B36, B37 EXHAUST AIR BLOWER (RRS)
- ⚠ A30 MAY BE USED WITH OR WITHOUT A34 A34 MAY BE USED WITH OR WITHOUT A30
- ⚠ SHIELDED WIRE
- ⚠ TO TRANSFER B3 BLOWER MOTOR FROM A96 VFD TO K3 CONTACTOR, TURN OFF POWER
 - 1. DISCONNECT WIRES MARKED K203-A AND K203-B AND CONNECT WIRE K203-A
- 2. UNPLUG J247 FROM P247, PLUG J249 TO P247
- 3. UNPLUG P248, PLUG IN P248 BYPASS JUMPER IF ALARM CONTACTS C AND B ON A96 ARE OPEN
- ⚠ B37 BLOWER MAY NOT BE USED

| | | |
|-------------------------------------|--|-------|
| 08/17 |  ENERGENCE WIRING DIAGRAM 537879-01 | 08/17 |
| LCH/LGH - 242,300,360 - G,J,Y (VAV) | | |
| SECTION B | | |
| Supersedes | New Form No. 537879-01 | |

LGH/LCH 300, 360 G, J, Y
WITH VFD CONTROL

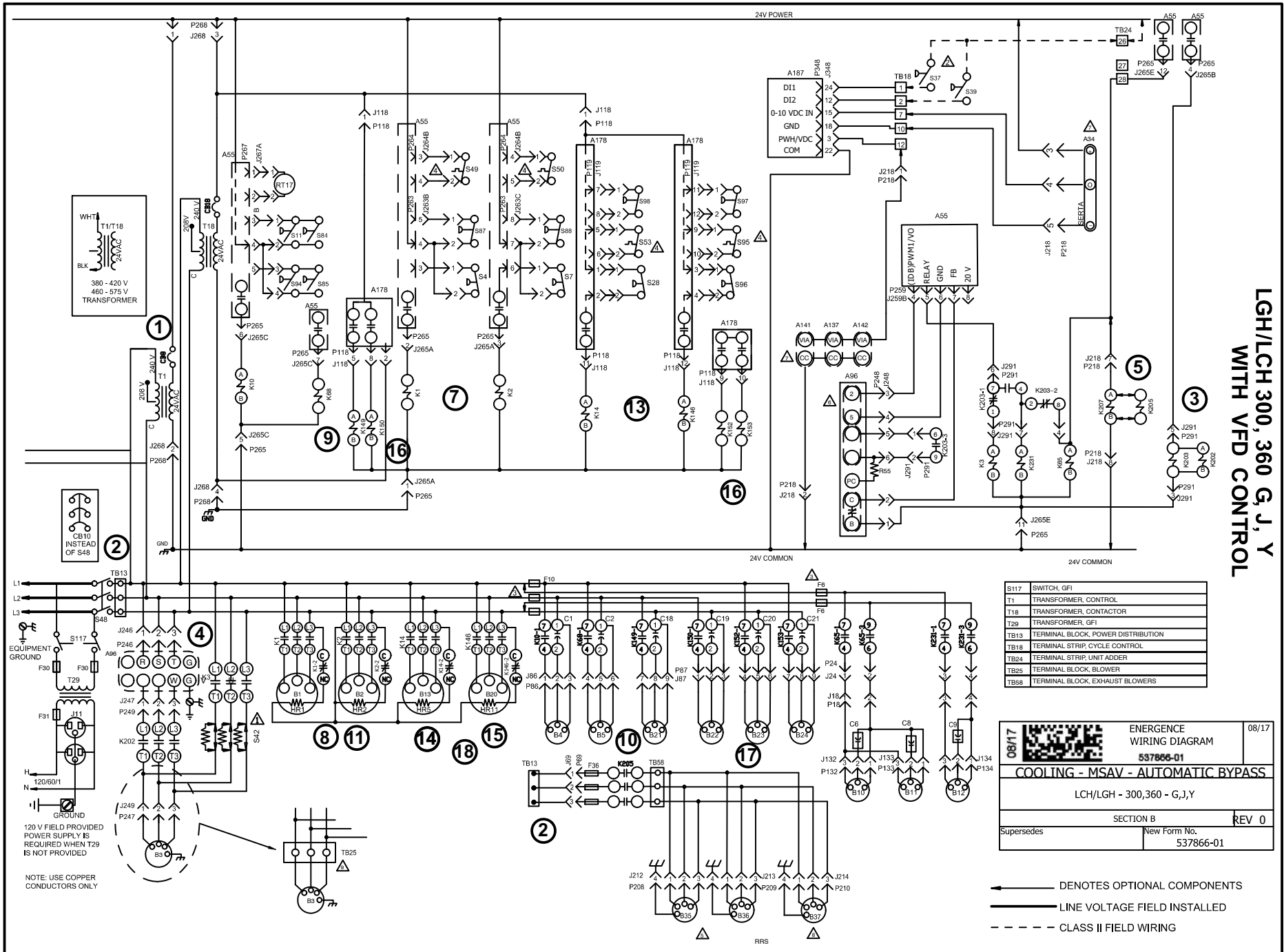

| | |
|------|------------------------------------|
| S117 | SWITCH, GFI |
| T1 | TRANSFORMER, CONTROL |
| T18 | TRANSFORMER, CONTACTOR |
| T29 | TRANSFORMER, GFI |
| TB13 | TERMINAL BLOCK, POWER DISTRIBUTION |
| TB18 | TERMINAL STRIP, CYCLE CONTROL |
| TB24 | TERMINAL STRIP, UNIT ADDER |
| TB25 | TERMINAL BLOCK, BLOWER |
| TB88 | TERMINAL BLOCK, EXHAUST BLOWERS |

| | | |
|-----------------------------------|--|-------|
| 08/17 | ENERGENCE WIRING DIAGRAM 537866-01 | 08/17 |
| COOLING - MSAV - AUTOMATIC BYPASS | | |
| LCH/LGH - 300,360 - G,J,Y | | |
| SECTION B | | REV 0 |
| Supersedes | New Form No. 537866-01 | |

- DENOTES OPTIONAL COMPONENTS
- LINE VOLTAGE FIELD INSTALLED
- - - CLASS II FIELD WIRING

120 V FIELD PROVIDED
POWER SUPPLY IS
REQUIRED WHEN T29
IS NOT PROVIDED

NOTE: USE COPPER
CONDUCTORS ONLY

| KEY | COMPONENT |
|------|---|
| A34 | DIFFERENTIAL PRESSURE TRANSDUCER |
| A55 | CONTROL BOARD, MAIN |
| A96 | CONTROL INVERTER |
| A137 | INVERTER, EXHAUST 1 |
| A141 | INVERTER, EXHAUST 2 |
| A142 | INVERTER, EXHAUST 3 |
| A178 | CONTROL BOARD, COMP 3 & 4, 2ND STAGE HEAT |
| A187 | CONTROL, GENERAL PURPOSE GP3 |
| B1 | COMPRESSOR 1 |
| B2 | COMPRESSOR 2 |
| B3 | MOTOR, BLOWER |
| B4 | MOTOR, OUTDOOR FAN 1 |
| B5 | MOTOR, OUTDOOR FAN 2 |
| B10 | MOTOR, EXHAUST FAN 1 |
| B11 | MOTOR, EXHAUST FAN 2 |
| B12 | MOTOR, EXHAUST FAN 3 |
| B13 | COMPRESSOR 3 |
| B20 | COMPRESSOR 4 |
| B21 | MOTOR, OUTDOOR FAN 3 |
| B22 | MOTOR, OUTDOOR FAN 4 |
| B23 | MOTOR, OUTDOOR FAN 5 |
| B24 | MOTOR, OUTDOOR FAN 6 |
| B35 | MOTOR, EXH. BLO 1 |
| B36 | MOTOR, EXH. BLO 2 |
| B37 | MOTOR, EXH. BLO 3 |
| C1 | CAPACITOR, OUTDOOR FAN 1 |
| C2 | CAPACITOR, OUTDOOR FAN 2 |
| C6 | CAPACITOR, EXHAUST FAN 1 |
| C8 | CAPACITOR, EXHAUST FAN 2 |
| C9 | CAPACITOR, EXHAUST FAN 3 |
| C18 | CAPACITOR, OUTDOOR FAN 3 |
| C19 | CAPACITOR, OUTDOOR FAN 4 |
| C20 | CAPACITOR, OUTDOOR FAN 5 |
| C21 | CAPACITOR, OUTDOOR FAN 6 |
| CB8 | CIRCUIT, BREAKER T1 |
| CB10 | CIRCUIT BREAKER, MAIN DISCONNECT UNIT |
| CB18 | CIRCUIT, BREAKER T1B |
| F6 | FUSE, EXHAUST FAN |
| F10 | FUSE, OUTDOOR FAN MOTOR |
| F30 | FUSE, TRANSFORMER T29 PRIMARY |
| F31 | FUSE, TRANSFORMER T29 SECONDARY |
| F36 | FUSE,P.E. BLOWERS |

| | |
|------|---|
| HR1 | HEATER COMPRESSOR 1 |
| HR2 | HEATER COMPRESSOR 2 |
| HR5 | HEATER COMPRESSOR 3 |
| HR11 | HEATER COMPRESSOR 4 |
| K1 | CONTACTOR, COMPRESSOR 1 |
| K2 | CONTACTOR, COMPRESSOR 2 |
| K3 | CONTACTOR, BLOWER |
| K10 | RELAY, OUTDOOR FAN 1 |
| K14 | CONTACTOR, COMPRESSOR 3 |
| K65 | RELAY, EXHAUST FAN |
| K68 | RELAY, OUTDOOR FAN 2 |
| K146 | CONTACTOR, COMPRESSOR 4 |
| K149 | RELAY, OUTDOOR FAN 3 |
| K150 | RELAY, OUTDOOR FAN 4 |
| K152 | RELAY, OUTDOOR FAN 5 |
| K153 | RELAY, OUTDOOR FAN 6 |
| K202 | CONTACTOR, INVERTER |
| K203 | RELAY INVERTER CONTROL |
| K205 | CONTACTOR,POWER EXHAUST |
| K207 | RELAY, EXHAUST BLOWER |
| K231 | RELAY, EXHAUST FAN 2 |
| R55 | RESISTOR, VFD LOADING, A96 |
| RT17 | SENSOR, OUTDOOR AIR |
| S4 | SWITCH, LIMIT HI PRESS COMPRESS 1 |
| S7 | SWITCH, LIMIT HI PRESS COMPRESS 2 |
| S11 | SWITCH, LOW PRESS, LOW AMBIENT COMP 1 |
| S31 | SWITCH, LIMIT HI TEMP COMPRESSOR 3 |
| S37 | SWITCH, PRESS, EXH |
| S39 | SWITCH, EXHAUST FAN |
| S42 | SWITCH, OVERLOAD RELAY BLOWER MOTOR |
| S48 | SWITCH, DISCONNECT |
| S49 | SWITCH, FREEZE STAT COMPRESS 1 |
| S50 | SWITCH, FREEZE STAT COMPRESS 2 |
| S53 | SWITCH, FREEZE STAT COMPRESS 3 |
| S84 | SWITCH, LOW PRESS, LOW AMBIENT COMP 2 |
| S85 | SWITCH, LOW PRESS, LOW AMBIENT COMP 3 |
| S87 | SWITCH, LOW PRESS, COMP 1 |
| S88 | SWITCH, LOW PRESS, COMP 2 |
| S94 | SWITCH, LOW PRESS, LOW AMBIENT KIT COMP 4 |
| S95 | SWITCH, FREEZE STAT COMPRESS 4 |
| S96 | SWITCH, LIMIT HI PRESS COMPRESS 4 |
| S97 | SWITCH, LOW PRESS, COMP 4 |
| S98 | SWITCH, LOW PRESS, COMP 3 |

| J/P | JACK/PLUG DESCRIPTION |
|-----|--------------------------------|
| 11 | GFI, RECEPTACLE |
| 18 | EXHAUST FAN COMP |
| 24 | EXHAUST FAN |
| 69 | INTERFACE |
| 86 | OUTDOOR FAN INTERFACE |
| 87 | OUTDOOR FAN INTERFACE 2 |
| 118 | CONTROL FOR COMPRESSOR 3 AND 4 |
| 119 | COMPRESSOR 3 AND 4, INPUT |
| 132 | EXHAUST FAN MOTOR 1 |
| 133 | EXHAUST FAN MOTOR 2 |
| 134 | EXHAUST FAN MOTOR 3 |
| 208 | MOTOR, EXH BLO, B35 |
| 209 | MOTOR, EXH BLO, B36 |
| 210 | MOTOR, EXH BLO, B37 |
| 212 | MOTOR, EXH BLO, B35 |
| 213 | MOTOR, EXH BLO, B36 |
| 214 | MOTOR, EXH BLO, B37 |
| 218 | POWER EXHAUST CONTROL |
| 246 | POWER TO VFD |
| 247 | VFD TO MOTOR |
| 248 | VFD TO CONTROL |
| 249 | CONTACTOR BYPASS |
| 259 | BLOWER ECM MOTOR |
| 263 | HIGH AND LOW PRESSURE SWITCHES |
| 264 | BLOWER DECK |
| 265 | CONTACTORS AND RELAYS |
| 268 | 24V POWER FROM TRANSFORMERS |
| 291 | VFD BYPASS LOW VOLTAGE |
| 348 | CONTROL, GENERAL PURPOSE GP3 |

NOTES

⚠ S42 USED ON UNITS WITH VFD CONTROL WITH BYPASS OPTION, UNITS WITH HIGH EFFICIENCY MOTORS AND UNITS WITH MOTORS LESS INTERNAL OVERLOAD PROTECTION



⚠ F6 AND F10 FUSES ARE USED ON "Y" VOLTAGE UNITS ONLY

⚠ S49, S50, S53 AND S95 ARE A PART OF 5VDC CIRCUIT

⚠ FOR P.E. INVERTER WIRING, REFER TO RRS ASSEMBLY



⚠ A34 SENSOR AND A137, A141, A142 INVERTER CONTROL FOR B35, B36, B37 EXHAUST AIR BLOWER (RRS)

⚠ B37 BLOWER MAY NOT BE USED



⚠ TB25 USED IN PLACE OF P247/J249 ON Y VOLT UNITS

LGH/LCH 300, 360 G, J, Y
WITH VFD CONTROL

| | | | |
|--|---|---|-------|
| 08/17 |  | ENERGENCE WIRING DIAGRAM 537866-01 | 08/17 |
| COOLING - MSAV - AUTOMATIC BYPASS | | | |
| LCH/LGH - 300,360 - G,J,Y | | | |
| SECTION B | | | REV 0 |
| Supersedes | New Form No. 537866-01 | | |

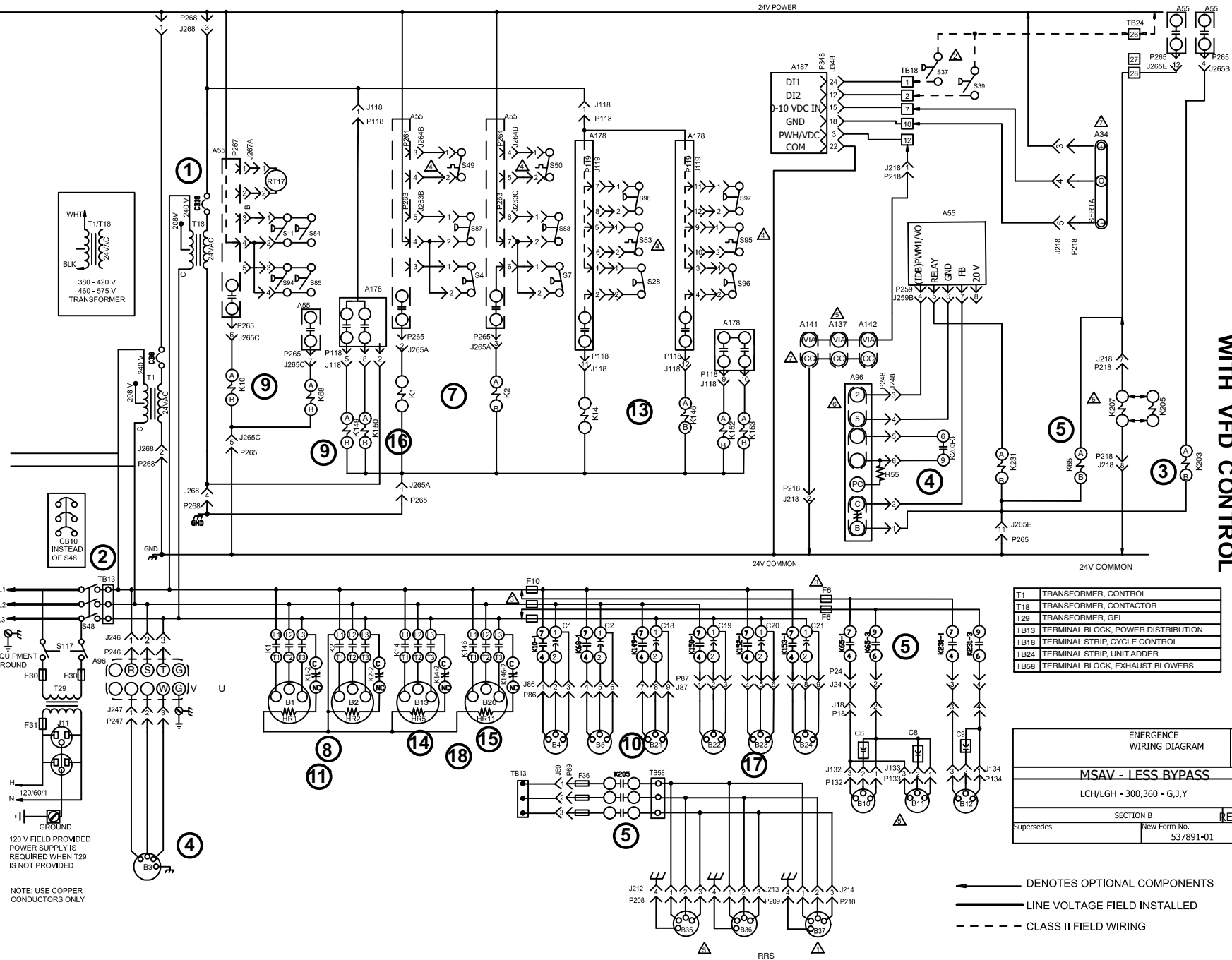

**LGH/LCH 300, 360 G, J, Y
WITH VFD CONTROL**

| | |
|------|------------------------------------|
| T1 | TRANSFORMER, CONTROL |
| T18 | TRANSFORMER, CONTACTOR |
| T29 | TRANSFORMER, GFI |
| TB13 | TERMINAL BLOCK, POWER DISTRIBUTION |
| TB18 | TERMINAL STRIP, CYCLE CONTROL |
| TB24 | TERMINAL STRIP, UNIT ADDER |
| TB58 | TERMINAL BLOCK, EXHAUST BLOWERS |

| | | |
|-----------------------------|--------------|-----------|
| ENERGENCE WIRING DIAGRAM | | 08/17 |
| MSAV - I LESS BYPASS | | |
| LCH/LGH - 300,360 - G,J,Y | | |
| SECTION B | | REV 0 |
| Supersedes | New Form No. | 537891-01 |

- DENOTES OPTIONAL COMPONENTS
- LINE VOLTAGE FIELD INSTALLED
- - - CLASS II FIELD WIRING

120 V FIELD PROVIDED
POWER SUPPLY IS
REQUIRED WHEN T29
IS NOT PROVIDED

NOTE: USE COPPER
CONDUCTORS ONLY

| KEY | COMPONENT |
|------|---|
| A34 | DIFFERENTIAL PRESSURE TRANSDUCER |
| A55 | CONTROL BOARD, MAIN |
| A96 | CONTROL INVERTER |
| A137 | CONTROL, INVERTER, RETURN |
| A141 | INVERTER, EXHAUST 2 |
| A142 | INVERTER, EXHAUST 3 |
| A178 | CONTROL BOARD, COMP 3 & 4, 2ND STAGE HEAT |
| A187 | CONTROL, GENERAL PURPOSE GP3 |
| B1 | COMPRESSOR 1 |
| B2 | COMPRESSOR 2 |
| B3 | MOTOR, BLOWER |
| B4 | MOTOR, OUTDOOR FAN 1 |
| B5 | MOTOR, OUTDOOR FAN 2 |
| B10 | MOTOR, EXHAUST FAN 1 |
| B11 | MOTOR, EXHAUST FAN 2 |
| B12 | MOTOR, EXHAUST FAN 3 |
| B13 | COMPRESSOR 3 |
| B20 | COMPRESSOR 4 |
| B21 | MOTOR, OUTDOOR FAN 3 |
| B22 | MOTOR, OUTDOOR FAN 4 |
| B23 | MOTOR, OUTDOOR FAN 5 |
| B24 | MOTOR, OUTDOOR FAN 6 |
| B35 | MOTOR, EXH, BLO 1 |
| B36 | MOTOR, EXH, BLO 2 |
| B37 | MOTOR, EXH, BLO 3 |
| C1 | CAPACITOR, OUTDOOR FAN 1 |
| C2 | CAPACITOR, OUTDOOR FAN 2 |
| C6 | CAPACITOR, EXHAUST FAN 1 |
| C8 | CAPACITOR, EXHAUST FAN 2 |
| C9 | CAPACITOR, EXHAUST FAN 3 |
| C18 | CAPACITOR, OUTDOOR FAN 3 |
| C19 | CAPACITOR, OUTDOOR FAN 4 |
| C20 | CAPACITOR, OUTDOOR FAN 5 |
| C21 | CAPACITOR, OUTDOOR FAN 6 |
| CB8 | CIRCUIT BREAKER T1 |
| CB10 | CIRCUIT BREAKER, MAIN DISCONNECT UNIT |
| CB18 | CIRCUIT, BREAKER T18 |

| | |
|------|---|
| F6 | FUSE, EXHAUST FAN |
| F10 | FUSE, OUTDOOR FAN MOTOR |
| F30 | FUSE, TRANSFORMER T29 PRIMARY |
| F31 | FUSE, TRANSFORMER T29 SECONDARY |
| F36 | FUSE, P.E. BLOWERS |
| HR1 | HEATER COMPRESSOR 1 |
| HR2 | HEATER COMPRESSOR 2 |
| HR5 | HEATER COMPRESSOR 3 |
| HR11 | HEATER COMPRESSOR 4 |
| K1 | CONTACTOR, COMPRESSOR 1 |
| K2 | CONTACTOR, COMPRESSOR 2 |
| K10 | RELAY, OUTDOOR FAN 1 |
| K14 | CONTACTOR, COMPRESSOR 3 |
| K65 | RELAY, EXHAUST FAN |
| K66 | RELAY, OUTDOOR FAN 2 |
| K146 | CONTACTOR, COMPRESSOR 4 |
| K149 | RELAY, OUTDOOR FAN 3 |
| K150 | RELAY, OUTDOOR FAN 4 |
| K152 | RELAY, OUTDOOR FAN 5 |
| K153 | RELAY, OUTDOOR FAN 6 |
| K203 | RELAY INVERTER CONTROL |
| K205 | CONTACTOR, POWER EXHAUST |
| K207 | RELAY, EXHAUST BLOWER |
| K231 | RELAY, EXHAUST FAN 2 |
| R55 | RESISTOR, VFD LOADING, A96 |
| RT17 | SENSOR, OUTDOOR AIR |
| S4 | SWITCH, LIMIT HI PRESS COMPRESS 1 |
| S7 | SWITCH, LIMIT HI PRESS COMPRESS 2 |
| S11 | SWITCH, LOW PRESS, LOW AMBIENT COMP 1 |
| S31 | SWITCH, LIMIT HI TEMP COMPRESSOR 3 |
| S37 | SWITCH, PRESS, EXH |
| S39 | SWITCH, EXHAUST FAN |
| S48 | SWITCH, DISCONNECT |
| S49 | SWITCH, FREEZE STAT COMPRESS 1 |
| S50 | SWITCH, FREEZE STAT COMPRESS 2 |
| S53 | SWITCH, FREEZE STAT COMPRESS 3 |
| S84 | SWITCH, LOW PRESS, LOW AMBIENT COMP 2 |
| S85 | SWITCH, LOW PRESS, LOW AMBIENT COMP 3 |
| S87 | SWITCH, LOW PRESS, COMP 1 |
| S88 | SWITCH, LOW PRESS, COMP 2 |
| S94 | SWITCH, LOW PRESS, LOW AMBIENT KIT COMP 4 |
| S95 | SWITCH, FREEZE STAT COMPRESS 4 |
| S96 | SWITCH, LIMIT HI PRESS COMPRESS 4 |
| S97 | SWITCH, LOW PRESS, COMP 4 |
| S98 | SWITCH, LOW PRESS, COMP 3 |
| S117 | SWITCH, GFI |

| J/P | JACK/PLUG DESCRIPTION |
|-----|--------------------------------|
| 11 | GFI, RECEPTACLE |
| 18 | EXHAUST FAN COMP |
| 24 | EXHAUST FAN |
| 69 | POWER EXHAUST POWER |
| 86 | OUTDOOR FAN INTERFACE |
| 87 | OUTDOOR FAN INTERFACE 2 |
| 118 | CONTROL FOR COMPRESSOR 3 AND 4 |
| 119 | COMPRESSOR 3 AND 4, INPUT |
| 132 | EXHAUST FAN MOTOR 1 |
| 133 | EXHAUST FAN MOTOR 2 |
| 134 | EXHAUST FAN MOTOR 3 |
| 208 | MOTOR, EXH BLO, B35 |
| 209 | MOTOR, EXH BLO, B36 |
| 210 | MOTOR, EXH BLO, B37 |
| 212 | MOTOR, EXH BLO, B35 |
| 213 | MOTOR, EXH BLO, B36 |
| 214 | MOTOR, EXH BLO, B37 |
| 218 | POWER EXHAUST CONTROL |
| 246 | POWER TO VFD |
| 247 | VFD TO MOTOR |
| 248 | VFD TO CONTROL |
| 259 | BLOWER ECM MOTOR |
| 263 | HIGH AND LOW PRESSURE SWITCHES |
| 264 | BLOWER DECK |
| 265 | CONTACTORS AND RELAYS |
| 268 | 24V POWER FROM TRANSFORMERS |
| 348 | CONTROL, GENERAL PURPOSE GP3 |

NOTES

- ⚠ B37 BLOWER MAY NOT BE USED
- ⚠ S37 AND S39 PRESSURE SWITCH CONTROL FOR POWER EXHAUST
- ⚠ F6 AND F10 FUSES ARE USED ON "Y" VOLTAGE UNITS ONLY
- ⚠ S49, S50, S53 AND S95 ARE A PART OF 5VDC CIRCUIT
- ⚠ FOR POWER EXHAUST INVERTER WIRING, REFER TO RRS ASSEMBLY
- ⚠ A96 INVERTER CONTROL FOR B3 SUPPLY AIR BLOWER
- ⚠ A34 SENSOR AND A137, A141, A142 INVERTER CONTROL FOR B35, B36, B37 EXHAUST AIR BLOWER (RRS)

**LGH/LCH 300, 360 G, J, Y
WITH VFD CONTROL**

| | | |
|---------------------------|------------------------|--------------|
| ENERGENCE WIRING DIAGRAM | | 08/17 |
| MSAV - LESS BYPASS | | |
| LCH/LGH - 300,360 - G,J,Y | | |
| SECTION B | | REV 0 |
| Supersedes | New Form No. 537891-01 | |

LGH/LCH300, 360 M LESS VFD

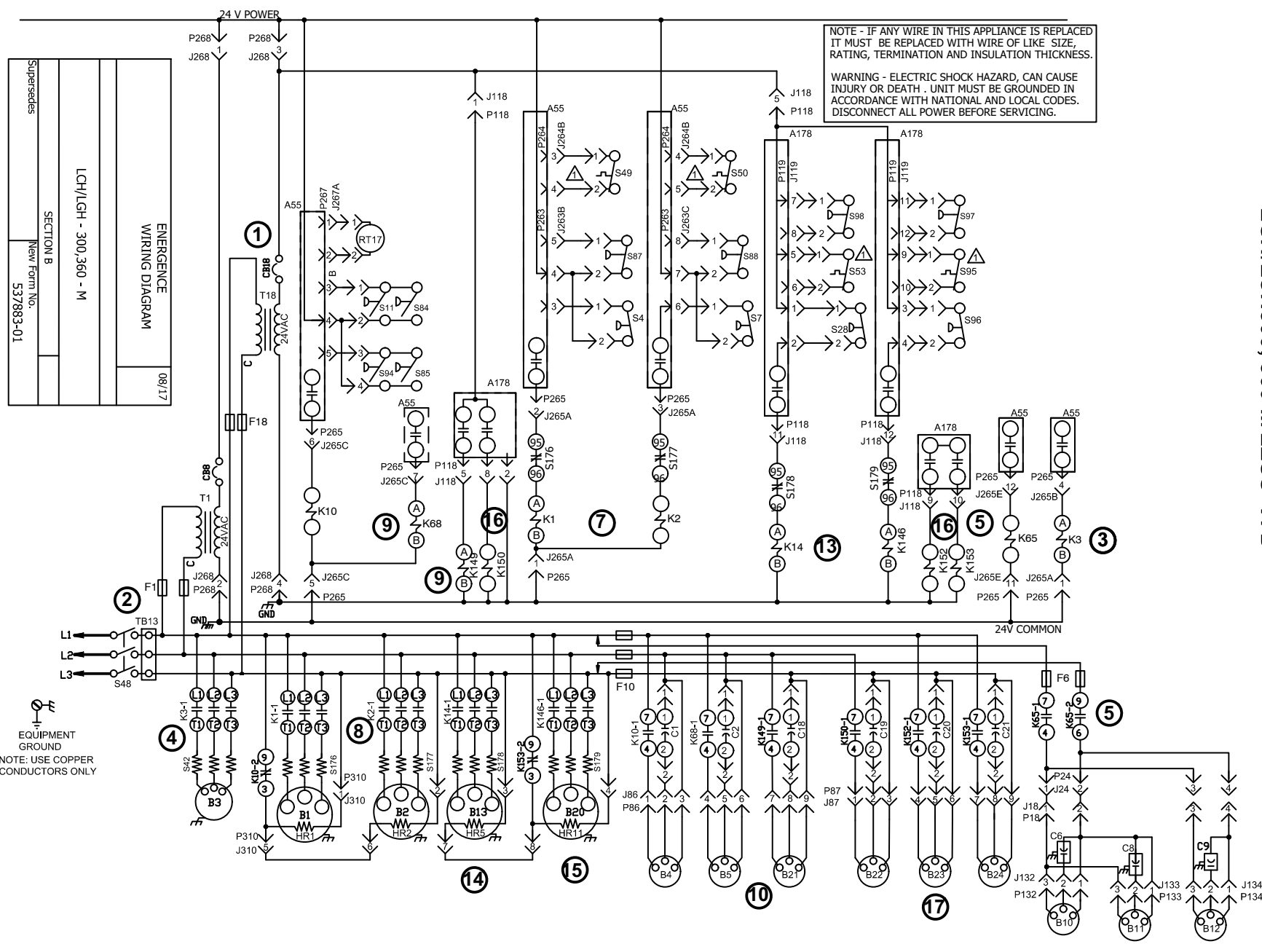

| | |
|--------------------------|-----------|
| Supersedes | |
| LGH/LCH - 300, 360 - M | |
| SECTION B | |
| New Form No. | 537883-01 |
| EMERGENCY WIRING DIAGRAM | 08/17 |

NOTE - IF ANY WIRE IN THIS APPLIANCE IS REPLACED IT MUST BE REPLACED WITH WIRE OF LIKE SIZE, RATING, TERMINATION AND INSULATION THICKNESS.

WARNING - ELECTRIC SHOCK HAZARD, CAN CAUSE INJURY OR DEATH. UNIT MUST BE GROUNDED IN ACCORDANCE WITH NATIONAL AND LOCAL CODES. DISCONNECT ALL POWER BEFORE SERVICING.

EQUIPMENT GROUND
NOTE: USE COPPER CONDUCTORS ONLY

| KEY | COMPONENT DESCRIPTION |
|-----------|---|
| A55 | CONTROL BOARD, MAIN |
| A178 | CONTROL BOARD, COMP 3 & 4, 2ND STAGE HEAT |
| B1 | COMPRESSOR 1 |
| B2 | COMPRESSOR 2 |
| B3 | MOTOR, BLOWER |
| B4 | MOTOR, OUTDOOR FAN 1 |
| B5 | MOTOR, OUTDOOR FAN 2 |
| B10 | MOTOR, EXHAUST FAN 1 |
| B11 | MOTOR, EXHAUST FAN 2 |
| B12 | MOTOR, EXHAUST FAN 3 |
| B13 | COMPRESSOR 3 |
| B20 | COMPRESSOR 4 |
| B21 | MOTOR, OUTDOOR FAN 3 |
| B22 | MOTOR, OUTDOOR FAN 4 |
| B23 | MOTOR, OUTDOOR FAN 5 |
| B24 | MOTOR, OUTDOOR FAN 6 |
| C1 | CAPACITOR, OUTDOOR FAN 1 |
| C2 | CAPACITOR, OUTDOOR FAN 2 |
| C6 | CAPACITOR, EXHAUST FAN 1 |
| C8 | CAPACITOR, EXHAUST FAN 2 |
| C9 | CAPACITOR, EXHAUST FAN 3 |
| C18 | CAPACITOR, OUTDOOR FAN 3 |
| C19 | CAPACITOR, OUTDOOR FAN 4 |
| C20 | CAPACITOR, OUTDOOR FAN 5 |
| C21 | CAPACITOR, OUTDOOR FAN 6 |
| CB8 | CIRCUIT, BREAKER T1 |
| CB18 | CIRCUIT, BREAKER T18 |
| F1 | FUSE, TRANSFORMER, T1 |
| F6 | FUSE, EXHAUST FAN |
| F10 | FUSE, OUTDOOR FAN MOTOR |
| F18 | FUSE, TRANSFORMER, T18 |
| HR1 | HEATER COMPRESSOR 1 |
| HR2 | HEATER COMPRESSOR 2 |
| HR5 | HEATER COMPRESSOR 3 |
| HR11 | HEATER COMPRESSOR 4 |
| K1,-1 | CONTACTOR, COMPRESSOR 1 |
| K2,-1 | CONTACTOR, COMPRESSOR 2 |
| K3-1 | CONTACTOR, BLOWER |
| K10,-1,2 | RELAY, OUTDOOR FAN 1 |
| K14-01 | CONTACTOR, COMPRESSOR 3 |
| K65-1,2 | RELAY, EXHAUST FAN |
| K68,-1 | RELAY,OUTDOOR FAN 2 |
| K146-1 | CONTACTOR, COMPRESSOR 4 |
| K149-1 | RELAY, OUTDOOR FAN 3 |
| K150,-1 | RELAY, OUTDOOR 4 |
| K152-1 | RELAY, OUTDOOR 5 |
| K153-1,-2 | RELAY, OUTDOOR FAN 6 |
| RT17 | SENSOR, OUTDOOR AIR |
| S4 | SWITCH, LIMIT HI PRESS COMPRESS 1 |
| S7 | SWITCH, LIMIT HI PRESS COMPRESS 2 |
| S11 | SWITCH, LOW PRESS, LOW AMBIENT COMP 1 |
| S28 | SWITCH, LIMIT HI PRESS COMPRESS 3 |
| S42 | SWITCH, OVERLOAD RELAY BLOWER MOTOR |
| S48 | SWITCH, DISCONNECT |
| S49 | SWITCH, FREEZE STAT COMPRESS 1 |
| S50 | SWITCH, FREEZE STAT COMPRESS 2 |
| S53 | SWITCH, FREEZE STAT COMPRESS 3 |

| | |
|------|---|
| S84 | SWITCH, LOW PRESS, LOW AMBIENT KIT COMP 2 |
| S85 | SWITCH, LOW PRESS, LOW AMBIENT KIT COMP 3 |
| S87 | SWITCH, LOW PRESS, COMP 1 |
| S88 | SWITCH, LOW PRESS, COMP 2 |
| S94 | SWITCH, LOW PRESS, LOW AMBIENT KIT COMP 4 |
| S95 | SWITCH, FREEZE STAT COMPRESS 4 |
| S96 | SWITCH, LIMIT HI PRESS COMPRESS 4 |
| S97 | SWITCH, LOW PRESS, COMP 4 |
| S98 | SWITCH, LOW PRESS, COMP 3 |
| S176 | SWITCH, OVERLOAD COMPRESSOR 1 |
| S177 | SWITCH, OVERLOAD COMPRESSOR 2 |
| S178 | SWITCH, OVERLOAD COMPRESSOR 3 |
| S179 | SWITCH, OVERLOAD COMPRESSOR 4 |
| T1 | TRANSFORMER, CONTROL |
| T18 | TRANSFORMER, CONTACTOR |
| TB13 | TERMINAL STRIP, POWER DISTRIBUTION |

| J/P | JACK/PLUG DESCRIPTION |
|-----|--------------------------------|
| 18 | EXHAUST FAN COMP |
| 24 | EXHAUST FAN |
| 86 | OUTDOOR FAN INTERFACE |
| 87 | OUTDOOR FAN INTERFACE 2 |
| 118 | COMPRESSOR 3 AND 4, CONTROL |
| 119 | COMPRESSOR 3 AND 4, INPUT |
| 132 | EXHAUST FAN MOTOR 1 |
| 133 | EXHAUST FAN MOTOR 2 |
| 134 | EXHAUST FAN MOTOR 3 |
| 263 | HIGH AND LOW PRESSURE SWITCHES |
| 264 | BLOWER DECK |
| 265 | CONTACTORS AND RELAYS |
| 267 | OUTDOOR FAN AREA |
| 268 | T1 TRANSFORMER |
| 310 | CRANKCASE HEATERS |

⚠ S49,S50,S53 AND S95 ARE PART OF 5VDC CIRCUIT

← DENOTES OPTIONAL COMPONENTS

— LINE VOLTAGE FIELD INSTALLED

| | | |
|--------------------------|---------------------------|-------|
| ENERGENCE WIRING DIAGRAM | | 08/17 |
| LCH/LGH - 300,360 - M | | |
| SECTION B | | |
| Supersedes | New Form No. 537883-01 | |

LGH/LCH300, 360 M LESS VFD

Sequence of Operation LGH/LCH242/300/360

POWER:

- 1- Line voltage from TB2, unit disconnect S48, or other factory or field installed optional power disconnects, such as CB10, energizes transformer T1 and T18. Transformer T1 provides 24VAC power to the A55 Unit Controller and T18 provides 24VAC power to A178 Compressor 3 and 4 Controller. The two controllers provide 24VAC power to the unit cooling, heating and blower controls and thermostat.
- 2- Terminal block TB13 is also energized when the unit disconnect closes. TB13 supplies line voltage to compressor crankcase heaters, compressors, blower motors and fan motors.

BLOWER OPERATION (OCP INPUT MUST BE ON):

- 3- The A55 Unit Controller receives a demand from thermostat terminal G. A55 energizes blower contactor K3 with 24VAC. On VFD units, A55 energizes relay K203.
- 4- N.O. K3-1 closes, energizing blower B3. On VFD units, N.O. K203-2 closes, sending a signal to the inverter, A96, to start forward rotation. P259 pin #4 sends a 0 -10VDC signal to A96 to control blower B3 speed.

POWER EXHAUST FANS/BLOWERS:

- 5- The A55 Unit Controller receives a demand and energizes exhaust fan relay K65 OR exhaust blower contactor K205 or exhaust blower relay K207.

1ST STAGE COOLING (BOTH COMPRESSORS B1 AND B2 ARE ENERGIZED):

- 6- First stage cooling demand energizes Y1 and G in the thermostat. G energizes blower, if blower is not already running (see step 3).

7- 24VAC is routed to the A55 Unit Controller. After A55 proves N.C. low pressure switch S87 and S88, N.C. freezestat S49 and S50 and N.C. high pressure switch S4 and S7, compressor contactors K1 and K2 are energized.

- 8- N.O. contacts K1-1 and K2-1 close energizing compressor B1 and B2.
- 9- A55 Unit Controller and A178 Controller energize fan contactor K10, K68, and K149 based on low ambient switch S11 and S84 inputs and predefined control logic.
- 10- N.O. contact K10-1, K68-1, K149-1 close energizing fan B4, B5 and B21 respectively.
- 11- N.C. Contacts K1-2 and K2-2 open de-energizing compressor 1 and 2 crankcase heater HR1 and HR2.

2ND STAGE COOLING:

- 12- Second stage cooling demand energizes Y2.
- 13- 24VAC is routed to A178 Compressor 3 and 4 Controller. After A178 proves N.C. low pressure switches S98 and S97, N.C. freezestats S53 and S95 and N.C. high pressure switches S28 and S96, compressor contactors K14 and K146 are energized.
- 14- N.O. contacts K14-1 close energizing compressor B13.
- 15- N.O. contacts K146-1 close energizing compressor B20.
- 16- A178 Controller energizes fan contactor K150, K152, K153 based on low ambient switch S85 and S94 inputs and predefined control logic.
- 17- N.O. contacts K150-1, K152-1 and K153-1 close energizing condenser fan B22, B23 and B24 respectively.
- 18- N.C contacts K14-2 and K146-2 open de-energizing compressor 3 and 4 crankcase heater HR5 and HR11.

GAS HEAT FOR LGH242/300/360

NOTE - On single stage heat, terminal H1 on gas valve GV1 and GV3 is not connected to terminal H2 on A55 Unit Controller.

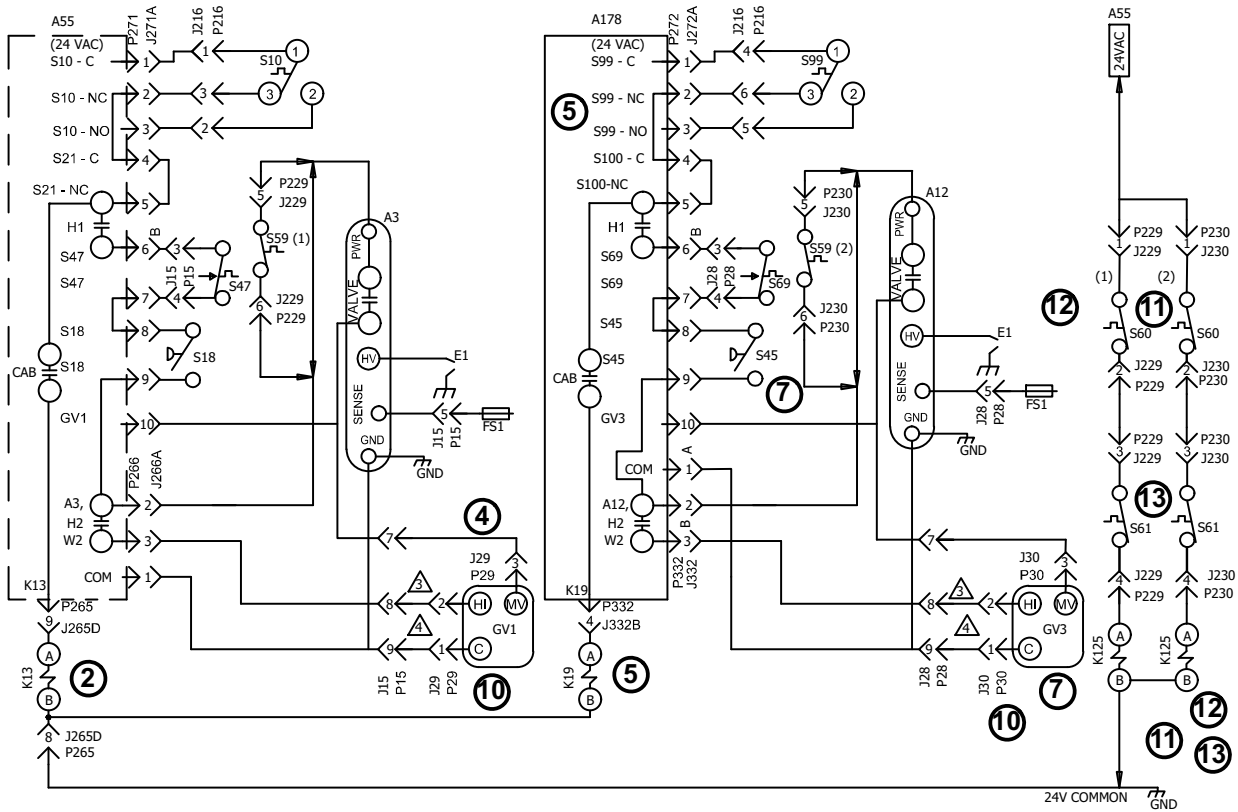

| KEY | DESCRIPTION |
|---------|--|
| A3 | CONTROL, BURNER 1 |
| A12 | CONTROL, BURNER 2 |
| A55 | CONTROL BOARD, MAIN |
| A178 | BOARD, COMP 3 & 4, 2ND STAGE HEAT - C3 |
| B6 | MOTOR COMBUSTION AIR BLOWER 1 |
| B15 | MOTOR COMBUSTION AIR BLOWER 2 |
| C3 | CAPACITOR, COMB AIR BLOWER 1 |
| C11 | CAPACITOR, COMB AIR BLOWER 2 |
| E1 | SPARK |
| FS1 | SENSOR, FLAME |
| GV1 | VALVE, GAS 1 |
| GV3 | VALVE, GAS 2 |
| HR6 | HEATER, -50C LOW AMBIENT KIT |
| K13,-1 | RELAY, COMBUSTION AIR BLOWER 1 |
| K19,-1 | RELAY, COMBUSTION AIR BLOWER 2 |
| K125,-1 | RELAY, HEAT SHUT OFF |
| S10 | SWITCH, LIMIT PRIMARY GAS |
| S18 | SWITCH, COMB AIR BLOWER 1 PROOF |
| S45 | SWITCH, COMB AIR BLOWER 2 PROOF |
| S47 | SWITCH, FLAME ROLLOUT BURNER |
| S59 | TSTAT, OPEN -20F, CLOSE 10F |
| S60 | TSTAT, OPEN 20F, CLOSE -10F |
| S61 | TSTAT, OPEN 50F, CLOSE 20F |
| S69 | SWITCH, FLAME ROLLOUT 2 |
| S99 | SWITCH, LIMIT PRIMARY BURNER 2 |
| T3 | TRANSFORMER, COMB AIR BLOWER 1 |
| T13 | TRANSFORMER, COMB AIR BLOWER 2 |

| J/P | DESCRIPTION |
|-----|----------------------------|
| 15 | BURNER 1 |
| 19 | COMBUSTION AIR BLOWER 1 |
| 21 | COMBUSTION AIR BLOWER 2 |
| 28 | BURNER 2 |
| 29 | GAS 1 HONEY WELL VALVE |
| 30 | GAS 2 HONEY WELL VALVE |
| 216 | PRIMARY LIMIT 1 |
| 228 | VESTIBULE HEATER |
| 229 | VESTIBULE HEATER CONTROL 1 |
| 230 | VESTIBULE HEATER CONTROL 2 |
| 265 | CONTACTOR RELAY |
| 266 | HEATING CONTROL STG 1 |
| 271 | HEATING SENSORS STG 1 |
| 272 | HEATING SENSORS STG 2 |
| 332 | HEATING CONTROL STG 2 |

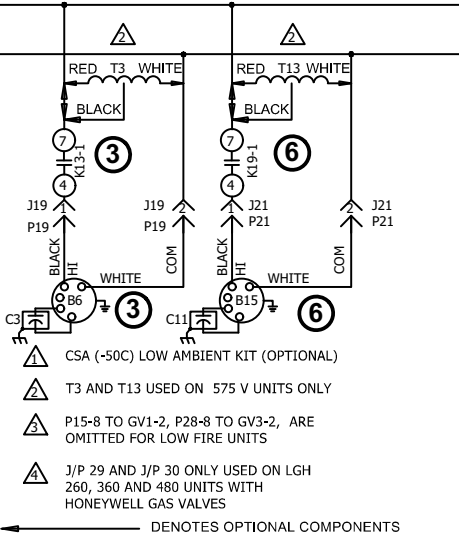

08/17
WIRING DIAGRAM
08/17

537695-03

HEATING

GAS HEAT FOR ENERGENCE
169,260,360 AND 480

SECTION A
REV. 0

Supersedes
New Form No.
537695-03

SEQUENCE OF OPERATION GAS HEAT FOR LGH242/300/360 UNITS

FIRST STAGE HEAT:

- 1 - Heating demand initiates at W1 in thermostat.
- 2 - 24VAC is routed to the A55 Unit Controller. After A55 proves N.C. primary limit S10, the combustion air blower relay K13 is energized.
- 3 - N.O. K13-1 contacts close allowing line voltage (or transformer T3 in 575V only) to energize combustion air blower B6.
- 4 - After the combustion air blower B6 has reached full speed, the combustion air proving switch (S18) contacts close. The A55 routes 24VAC through N.C. burner 1 flame rollout switch S47 and the closed contacts of the combustion air proving switch (S18) to energize the ignition module A3. After a 30 second delay A3 energizes the gas valve GV1 on low fire.
- 5 - As steps 2, 3 and 4 occur, A178 proves N.C. primary gas heat limit S99 and the combustion air blower relay K19 is energized.
- 6 - N.O. K19-1 contacts close allowing line voltage (or transformer T13 in 575V only) to energize combustion air blower B15.
- 7 - After the combustion air blower B15 has reached full speed, the combustion air proving switch (S45) contacts close. The A178 routes 24VAC through N.C. burner 2 flame rollout switch S69 and the closed contacts of the combustion air proving switch (S45) to energize the ignition module A12. After a 30 second delay A12 energizes gas valve GV3 on low fire.

SECOND STAGE HEAT:

- 8 - With first stage heat operating, an additional heating demand initiates W2 in the thermostat.
- 9 - A second stage heating demand is received by A55.

- 10 - A55 will energize the corresponding gas valves GV1 and GV3 on high fire.

OPTIONAL LOW AMBIENT KIT (C.G.A. -50°C LOW AMBIENT KIT):

- 11 - When heat section temperature drops below -20°F, S59 opens and de-energized A3 and A12 ignition controls. At the same temperature, S60 closes and energizes K125. K125-1 contacts close energizing HR6 Cold Weather Kit electric heat.
- 12 - When heat section temperature rises to 10°F, S59 closes allowing power to A3 and A12 ignition controls. At the same temperature, S60 opens and de-energizes K125. K125-1 contacts open de-energizing HR6 Cold Weather Kit electric heat.
- 13 - If heat section temperature rises above 50°F, S61 will open and de-energize K125. K125-1 contacts will open and de-energize HR6 Cold Weather Kit electric heat. If heat section temperature drops to 20°F, S61 will close and allow power to K125.

END OF SECOND STAGE HEAT:

- 14 - Heating demand is satisfied. Terminal W2 is de-energized.
- 15 - High fire on GV1 and GV3 are de-energized by the A55.

END OF FIRST STAGE HEAT:

- 16 - Heating demand is satisfied. Terminal W1 is de-energized.
- 17 - Ignition module A3 is de-energized by A55 in turn de-energizing GV1. Combustion blower relay K13 is also de-energized. At the same instant, ignition module A12 is de-energized by A55 in turn de-energizing GV3. K19 combustion air blower relay is also de-energized.

ELECTRIC HEAT DIAGRAM

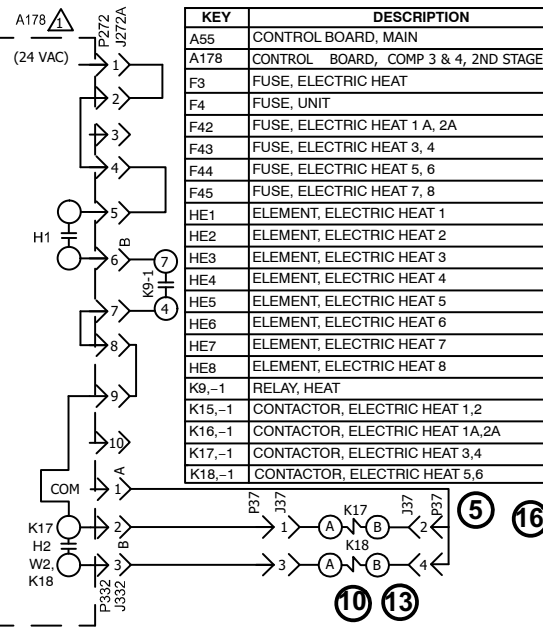
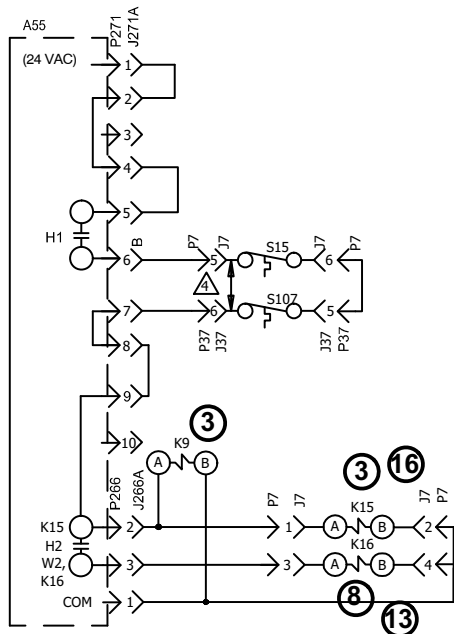

| KEY | DESCRIPTION |
|--------|---|
| A55 | CONTROL BOARD, MAIN |
| A178 | CONTROL BOARD, COMP 3 & 4, 2ND STAGE HEAT |
| F3 | FUSE, ELECTRIC HEAT |
| F4 | FUSE, UNIT |
| F42 | FUSE, ELECTRIC HEAT 1 A, 2A |
| F43 | FUSE, ELECTRIC HEAT 3, 4 |
| F44 | FUSE, ELECTRIC HEAT 5, 6 |
| F45 | FUSE, ELECTRIC HEAT 7, 8 |
| HE1 | ELEMENT, ELECTRIC HEAT 1 |
| HE2 | ELEMENT, ELECTRIC HEAT 2 |
| HE3 | ELEMENT, ELECTRIC HEAT 3 |
| HE4 | ELEMENT, ELECTRIC HEAT 4 |
| HE5 | ELEMENT, ELECTRIC HEAT 5 |
| HE6 | ELEMENT, ELECTRIC HEAT 6 |
| HE7 | ELEMENT, ELECTRIC HEAT 7 |
| HE8 | ELEMENT, ELECTRIC HEAT 8 |
| K9,-1 | RELAY, HEAT |
| K15,-1 | CONTACTOR, ELECTRIC HEAT 1,2 |
| K16,-1 | CONTACTOR, ELECTRIC HEAT 1A,2A |
| K17,-1 | CONTACTOR, ELECTRIC HEAT 3,4 |
| K18,-1 | CONTACTOR, ELECTRIC HEAT 5,6 |

| | |
|------|---|
| S15 | SWITCH, LIMIT PRIMARY ELECTRIC HEAT |
| S20 | SWITCH, LIMIT SECONDARY ELECTRIC HEAT 1,2 |
| S107 | SWITCH, PRIMARY ELECTRIC HEAT |
| S157 | SWITCH, LIMIT SECONDARY ELECTRIC HEAT 1A |
| S158 | SWITCH, LIMIT SECONDARY ELECTRIC HEAT 2A |
| S159 | SWITCH, LIMIT SECONDARY ELECTRIC HEAT 3,4 |
| S160 | SWITCH, LIMIT SECONDARY ELECTRIC HEAT 5,6 |
| TB2 | TERMINAL STRIP, UNIT |
| TB3 | TERMINAL STRIP, ELECTRIC HEAT |

| J/P | DESCRIPTION |
|-----|-----------------------|
| 7 | ELECTRIC HEAT CONTROL |
| 37 | ELECTRIC HEAT CONTROL |
| 266 | HEATING CONTROL STG 1 |
| 271 | HEATING SENSORS STG 1 |
| 272 | HEATING SENSORS STG 2 |
| 332 | HEATING CONTROL STG 2 |

| DESIGNATION | VOLTAGE |
|-------------|--------------|
| G | 460/60/3 |
| J | 575/60/3 |
| M | 380-420/50/3 |

C UNITS 156 TO 300
D UNITS 242 TO 360

- ⚠ NOT USED ON 15 AND 30KW UNITS
- ⚠ TB2, S48 OR CB10 MAY BE USED
- ⚠ TB3 IS USED IN SOME UNITS
- ⚠ REMOVE JUMPER PLUG WHEN FIELD INSTALLING ELECTRIC HEAT

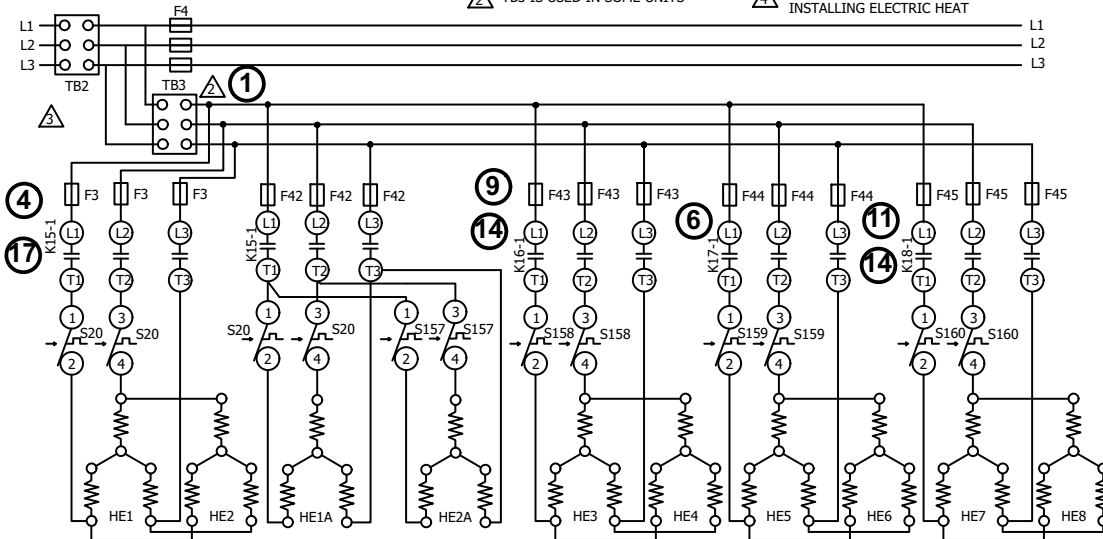

| C | KW | HE1 | HE2 | HE1A | HE2A | HE3 | HE4 | HE5 | HE6 | HE7 | HE8 |
|---|------|------|------|------|------|------|------|------|------|------|------|
| D | 15 | | | 7.5 | 7.5 | | | | | | |
| D | 30 | | | 15 | 15 | | | | | | |
| D | 45 | 15 | | | | 7.5 | | 15 | | 7.5 | |
| D | 60 | 15 | | | | 15 | | 15 | | 15 | |
| D | 90 | 15 | | | | 15 | 15 | 15 | | 15 | 15 |
| C | 120 | 15 | 15 | | | 15 | 15 | 15 | 15 | 15 | 15 |
| D | 11.5 | | | 5.7 | 5.7 | | | | | | |
| D | 23 | | | 11.5 | 11.5 | | | | | | |
| D | 34.5 | 11.5 | | | | 5.7 | | 11.5 | | 5.7 | |
| D | 45.9 | 11.5 | | | | 11.5 | | 11.5 | | 11.5 | |
| D | 68.9 | 11.5 | | | | 11.5 | 11.5 | 11.5 | | 11.5 | 11.5 |
| D | 91.8 | 11.5 | 11.5 | | | 11.5 | 11.5 | 11.5 | 11.5 | 11.5 | 11.5 |

← DENOTES OPTIONAL COMPONENTS

| | | |
|--|---|---------------------------|
| 08/17 | WIRING DIAGRAM ENERGENCE 537754-02 | 08/17 |
| ELECTRIC HEATING | | |
| E1EH,EHA-15,30,45,60,90,120 - G, J E1EH,EHA-11.5,23,34.5,45.9,68.9,91.8 - M | | |
| SECTION A | | REV.0 |
| Supersedes 537356-03,537184-04 | | New Form No. 537754-02 |

ELECTRIC HEAT DIAGRAM

| J/P | JACK/PLUG |
|-----|-----------------------|
| 7 | ELECTRIC HEAT CONTROL |
| 37 | ELECTRIC HEAT CONTROL |
| 266 | HEATING CONTROL STG 1 |
| 271 | HEATING SENSORS STG 1 |
| 272 | HEATING SENSORS STG 2 |
| 332 | HEATING CONTROL STG 2 |

| KEY | DESCRIPTION |
|------|--|
| A55 | CONTROL BOARD, MAIN |
| A178 | CONTROL, COMP 3 & 4, 2ND STAGE HEAT - C3 |
| F3 | FUSE, ELECTRIC HEAT |
| F4 | FUSE, UNIT |
| F42 | FUSE, ELECTRIC HEAT 1 A, 2A |
| F43 | FUSE, ELECTRIC HEAT 3 |
| F44 | FUSE, ELECTRIC HEAT 4 |

| | |
|--------|---|
| F45 | FUSE, ELECTRIC HEAT 5 |
| F46 | FUSE, ELECTRIC HEAT 6 |
| F49 | FUSE, ELECTRIC HEAT 7 |
| F50 | FUSE, ELECTRIC HEAT 8 |
| HE1 | ELEMENT, ELECTRIC HEAT 1 |
| HE2 | ELEMENT, ELECTRIC HEAT 2 |
| HE3 | ELEMENT, ELECTRIC HEAT 3 |
| HE4 | ELEMENT, ELECTRIC HEAT 4 |
| HE5 | ELEMENT, ELECTRIC HEAT 5 |
| HE6 | ELEMENT, ELECTRIC HEAT 6 |
| HE7 | ELEMENT, ELECTRIC HEAT 7 |
| HE8 | ELEMENT, ELECTRIC HEAT 8 |
| HE9 | ELEMENT, ELECTRIC HEAT 9 |
| HE10 | ELEMENT, ELECTRIC HEAT 10 |
| HE11 | ELEMENT, ELECTRIC HEAT 11 |
| HE12 | ELEMENT, ELECTRIC HEAT 12 |
| HE13 | ELEMENT, ELECTRIC HEAT 13 |
| HE14 | ELEMENT, ELECTRIC HEAT 14 |
| K9,-1 | RELAY, HEAT |
| K15,-1 | CONTACTOR, ELECTRIC HEAT 1,2 |
| K16,-1 | CONTACTOR, ELECTRIC HEAT 1A,2A |
| K17,-1 | CONTACTOR, ELECTRIC HEAT 3,4 |
| K18,-1 | CONTACTOR, ELECTRIC HEAT 5,6 |
| K242 | CONTACTOR, ELECTRIC HEAT 1 |
| K243 | CONTACTOR, ELECTRIC HEAT 2 |
| K244 | CONTACTOR, ELECTRIC HEAT 3 |
| K245 | CONTACTOR, ELECTRIC HEAT 4 |
| S15 | SWITCH, LIMIT PRIMARY ELECTRIC HEAT |
| S20 | SWITCH, LIMIT SECONDARY ELECTRIC HEAT 1,2 |
| S107 | SWITCH, PRIMARY ELECTRIC HEAT |
| S157 | SWITCH, LIMIT SECONDARY ELECTRIC HEAT 2 |
| S158 | SWITCH, LIMIT SECONDARY ELECTRIC HEAT 3 |
| S159 | SWITCH, LIMIT SECONDARY ELECTRIC HEAT 4 |
| S180 | SWITCH, LIMIT SECONDARY ELECTRIC HEAT 5 |
| S161 | SWITCH, LIMIT SECONDARY ELECTRIC HEAT 6 |
| S171 | SWITCH, LIMIT SECONDARY ELECTRIC HEAT 7 |
| S172 | SWITCH, LIMIT SECONDARY ELECTRIC HEAT 8 |
| TB2 | TERMINAL STRIP, UNIT |
| TB3 | TERMINAL STRIP, ELECTRIC HEAT |

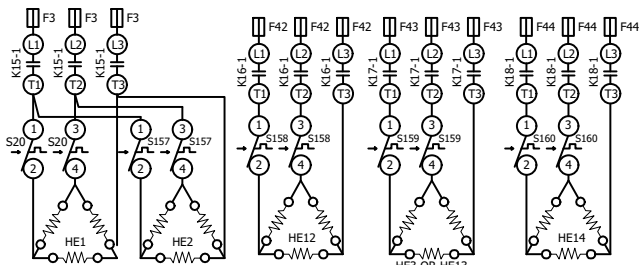
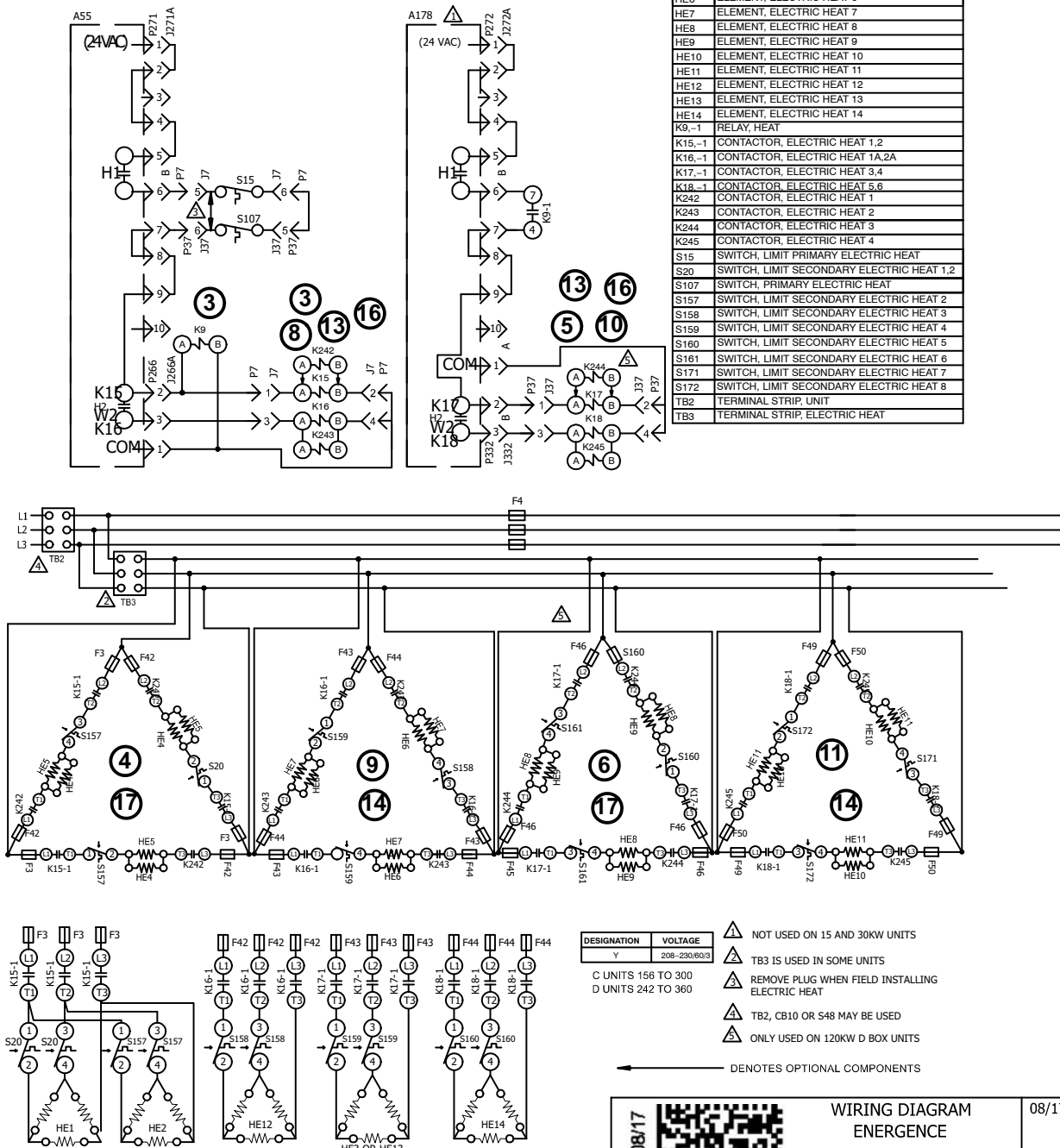

- | DESIGNATION | VOLTAGE | NOTES |
|-------------|--------------|---|
| Y | 208-230/60/3 | NOT USED ON 15 AND 30KW UNITS |
| C | | TB3 IS USED IN SOME UNITS |
| D | | REMOVE PLUG WHEN FIELD INSTALLING ELECTRIC HEAT |
| | | TB2, CB10 OR 548 MAY BE USED |
| | | ONLY USED ON 120KW D BOX UNITS |
- ← DENOTES OPTIONAL COMPONENTS

| D | KW | HE1 | HE2 | HE3 | HE4 | HE5 | HE6 | HE7 | HE8 | HE9 | HE10 | HE11 | HE12 | HE13 | HE14 |
|-----|-----|-----|-----|-----|-----|-----|-----|-----|-----|-----|------|------|------|------|------|
| 15 | 7.5 | 7.5 | | | | | | | | | | | | | |
| 30 | | | | 15 | 15 | | | | | | | | | | |
| 45 | 15 | | | | | | | | | | 7.5 | 15 | 7.5 | | |
| 60 | 15 | | | | | | | | | | 15 | 15 | 15 | | |
| 90 | 15 | | 15 | | | 15 | 15 | 15 | 15 | 15 | 15 | 15 | 15 | | |
| 120 | | | | 15 | 15 | 15 | 15 | 15 | 15 | 15 | 15 | 15 | 15 | | |

| | | |
|---|---|---------------------------|
| 08/17 | WIRING DIAGRAM ENERGENCE 537755-02 | 08/17 |
| ELECTRIC HEATING | | |
| E1EH, EHA - 15, 30, 45, 60, 90, 120 - Y | | |
| SECTION A | | REV 0 |
| Supersedes 537755-01, 537188-04 | | New Form No. 537755-02 |

ELECTRIC HEAT DIAGRAM

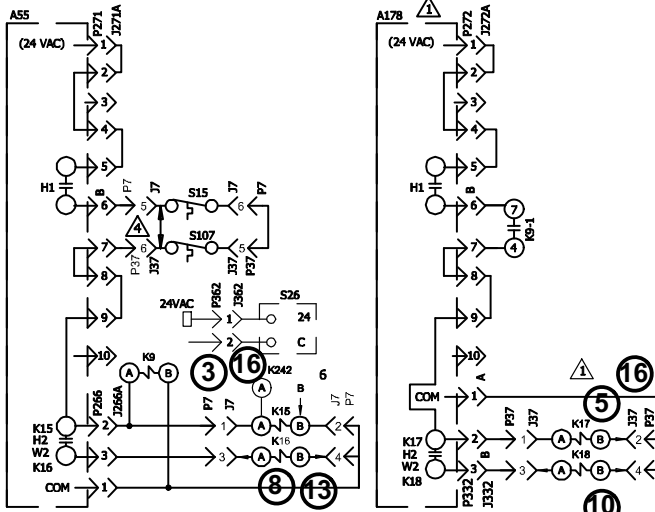

| KEY | DESCRIPTION |
|--------|--|
| A38 | CONTROL, SCR ELECTRIC HEAT |
| A65 | CONTROL, BOARD LENNOX |
| A104 | THERMOSTAT, SUPPLY AIR |
| A178 | BOARD, COMP 3 & 4, CS 2nd STAGE HEAT |
| F3 | FUSE, ELECTRIC HEAT |
| F4 | FUSE, UNIT |
| F42 | FUSE, ELECTRIC HEAT 1 A, 2A |
| F43 | FUSE, ELECTRIC HEAT 3, 4 |
| F44 | FUSE, ELECTRIC HEAT 5 |
| HE1A | ELEMENT, ELECTRIC HEAT 1A |
| HE2A | ELEMENT, ELECTRIC HEAT 2A |
| HE1 | ELEMENT, ELECTRIC HEAT 1 |
| HE2 | ELEMENT, ELECTRIC HEAT 2 |
| HE3 | ELEMENT, ELECTRIC HEAT 3 |
| HE4 | ELEMENT, ELECTRIC HEAT 4 |
| HE5 | ELEMENT, ELECTRIC HEAT 5 |
| K9-1 | RELAY, HEAT |
| K15,-1 | CONTACTOR, ELECTRIC HEAT 1 or 1A,2A |
| K16,-1 | CONTACTOR, ELECTRIC HEAT 3 |
| K17,-1 | CONTACTOR, ELECTRIC HEAT 4 |
| K18,-1 | CONTACTOR, ELECTRIC HEAT 5 |
| K181-1 | RELAY, SCR INTERRUPT |
| K182-1 | CONTACTOR, SCR HIGH OUTPUT |
| K211-1 | RELAY, HEAT LOCKOUT |
| K242-1 | CONTACTOR, ELECTRIC HEAT 2 |
| RT20 | SENSOR, DISCHARGE, SCR |
| S15 | SWITCH, LIMIT PRIMARY ELECTRIC HEAT |
| S28 | THERMOSTAT, AMBIENT |
| S20 | SWITCH, LIMIT SECONDARY ELECT HT 1 or 1A |
| S107 | SWITCH, PRIMARY ELECTRIC HEAT |
| S157 | SWITCH, LIMIT SECONDARY ELECT HT 2 or 2A |
| S158 | SWITCH, LIMIT SECONDARY ELECT HT 3 |
| S159 | SWITCH, LIMIT SECONDARY ELECT HT 4 |
| S160 | SWITCH, LIMIT SECONDARY ELECT HT 5 |
| TB2 | TERMINAL BLOCK, UNIT |
| TB3 | TERMINAL BLOCK, ELECTRIC HEAT |
| TB36 | TERMINAL STRIP, SCR |

| JIP | JACKPLUG DESCRIPTION |
|-----|--------------------------|
| 7 | ELECTRIC HEAT CONTROL |
| 37 | ELECTRIC HEAT CONTROL |
| 268 | HEATING CONTROL STG 1 |
| 271 | HEATING SENSORS STG 1 |
| 272 | HEATING SENSORS STG 2 |
| 297 | THERMOSTAT DDC INTERFACE |
| 298 | IAQ INTERFACE |
| 332 | HEATING CONTROL STG 2 |
| 362 | SCR-526 |

| DESIGNATION | VOLTAGE | C UNITS 156 - 300S | D UNITS 242H TO 360H |
|-------------|--------------|--------------------|----------------------|
| Y | 208-230/60/3 | | |

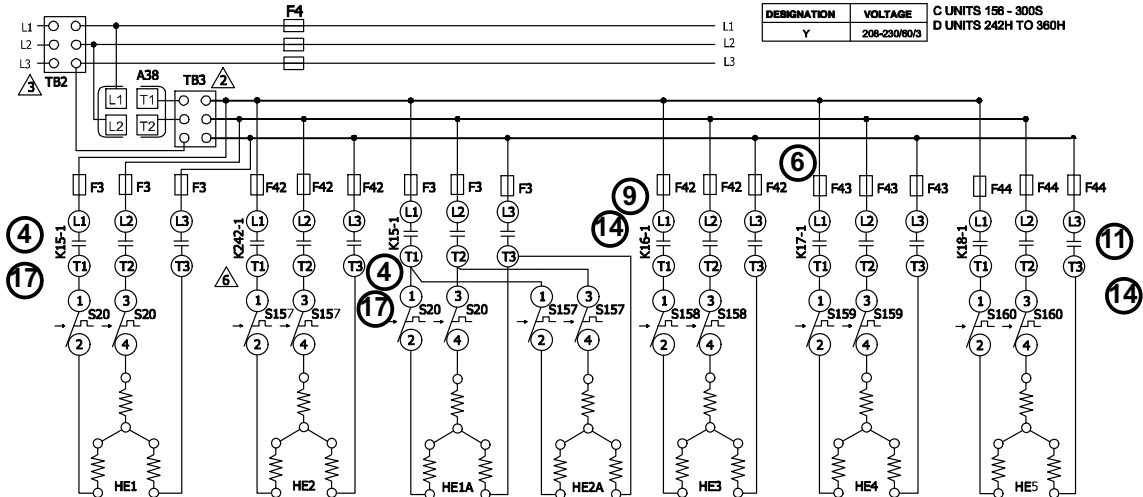
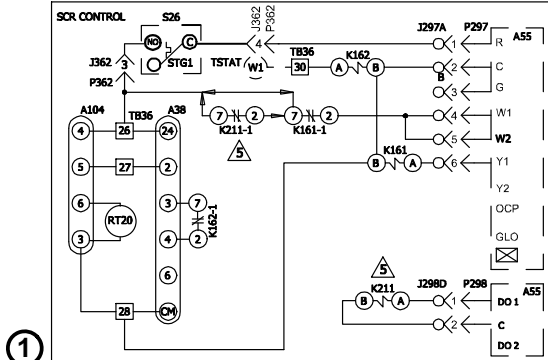

- 1 NOT USED ON 15 AND 30KW UNITS
 - 2 TB3 IS USED IN SOME UNITS
 - 3 TB2, S48 OR CB10 MAY BE USED
 - 4 REMOVE JUMPER PLUG WHEN FIELD INSTALLING ELECTRIC HEAT
 - 5 K211 USED WITH HUMIDITROL
 - 6 K242 USED ON 30KW UNITS ONLY
- ← DENOTES OPTIONAL COMPONENTS

| C | KW | SCR AMPS | | | | | | | | |
|----|-----|----------|------|-----|-----|-----|-----|-----|-----|-----|
| | | HE1A | HE2A | HE1 | HE2 | HE3 | HE4 | HE5 | 208 | 240 |
| 15 | 7.5 | 7.5 | | | | | | | 30 | 40 |
| 30 | | | 15 | 15 | | | | | 75 | 75 |
| 45 | | | 15 | | 7.5 | 15 | 7.5 | 135 | 135 | |

09/17
WIRING DIAGRAM
09/17

537757-02

HEATING - SCR

SCR ELECTRIC HEAT CONTROL - STAND ALONE

15, 30, 45 KW - Y

SECTION A
REV 0

Supersedes
537757-01
New Form No.
537757-02

SEQUENCE OF OPERATION
EHA-30, 45, 60, 90, 120 - Y
EHA-30, 45, 60, 90, -120 - G, J and M

The Y voltage diagram use elements configured in a Wye. The G and J voltage diagram use elements configured in a Delta. Both diagrams follow the following sequence of operation:

NOTE: Two electric heat sections are used in all 30kW through 120kW heaters. The heat sections are labelled first electric heat section (left side) and second electric heat section (right side). See figure 29.

NOTE: In the case of EHA30kW, the second heat section (right side) is a slave (only has electric heat elements and a limit). Line voltage is supplied to elements in both heat section one (left side) and two (right side) by the contactors in heat section one (left side).

HEATING ELEMENTS:

- 1 - Terminal block TB3 is energized when the unit disconnect closes. TB3 supplies line voltage to electric heat elements HE1 through HE14. Each heating element is protected by fuse F3.

FIRST STAGE HEAT:

- 2 - Heating demand initiates at W1 in thermostat.
- 3 - 24VAC is routed to the main control module A55. After A55 proves N.C. primary limits S15 (heat section one, left side), S107 (heat section two, right side), the electric heat contactor K15 and heat relay K9 are energized.
- 4 - N.O. contact K15-1 closes allowing the first bank of elements in heat section one (left side) to be energized.
- 5 - At the same time, N.O. contacts K9-1 close. A N.O. contact in A55 closes, energizing electric heat relay K17.

- 6 - N.O. contacts K17-1 close allowing the first set of elements in heat section two (right side) to be energized.

SECOND STAGE HEAT:

- 7 - With the first stage heat operating, an additional heating demand initiates at W2 in the thermostat.
- 8 - 24VAC is routed through the main control module A55, which in turn energizes the electric heat contactor K16.
- 9 - N.O. contacts K16-1 close allowing the second set of elements in heat section one (left side) to be energized.
- 10 - Simultaneous with step eight, a N.O. contact in the A178 Unit controller closes, allowing 24VAC to energize electric heat contactor K18.
- 11 - N.O. contacts K18-1 close allowing the second set of elements in heat section two (right side) to be energized.

END OF SECOND STAGE HEAT:

- 12 - Heating demand is satisfied. Terminal W2 in the thermostat is de-energized.
- 13 - Electric heat contactors K16 and K18 are de-energized.
- 14 - The second set of electric heat elements in heat sections one (left side) and two (right side) are de-energized.

END OF FIRST STAGE HEAT:

- 15 - Heating demand is satisfied. Terminal W1 in the thermostat is de-energized.
- 16 - Electric heat contactors K15 and K17 are de-energized.
- 17 - The first set of electric heat elements in heat sections one (left side) and two (right side) are de-energized.

ELECTRONIC OR ELECTROMECHANICAL THERMOSTAT

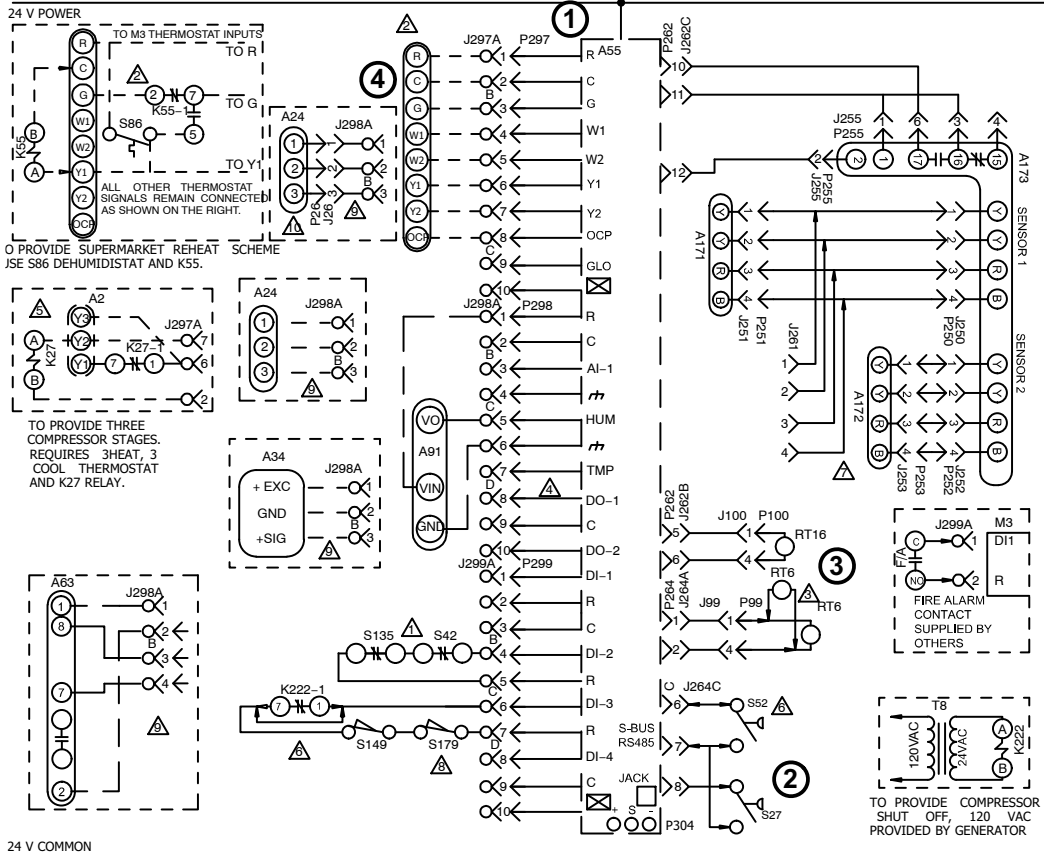

| KEY | DESCRIPTION | COMPONENT | DESCRIPTION |
|------|---------------------------------------|-----------|--|
| A2 | SENSOR, ELECTRONIC THERMOSTAT | | P253 PLUG, SMOKE DETECTOR TWO |
| A24 | CONTROL, OUTDOOR AIR CFM FLOW | | P255 PLUG, MODULE, CONTROL SMOKE DETECTION |
| A34 | DIFFERENTIAL PRESSURE TRANSDUCER | | P262 PLUG, ECONOMIZER |
| A55 | CONTROLBOARD, MAIN | | P264 PLUG, BLOWER DECK |
| A63 | SENSOR, CO2 (IAQ) OPTIONAL | | P297 PLUG, THERMOSTAT - DDC INTERFACE |
| A91 | SENSOR, HUMIDITY | | P298 PLUG, IAQ INTERFACE |
| A171 | SENSOR ONE, SMOKE, RETURN AIR | | P299 PLUG, SAFETY INTERFACE |
| A172 | SENSOR TWO, SMOKE, SUPPLY AIR | | P304 PLUG, SYS BUS |
| A173 | MODULE, CONTROL SMOKE DETECTION | | RT16 SENSOR, RETURN AIR TEMP |
| J26 | JACK, AIR FLOW CONTROL | | RT6 SENSOR, SUPPLY AIR TEMP |
| J99 | JACK, RT16 RETURN AIR SENSOR | | S27 SWITCH, FILTER |
| J100 | JACK, RT6 SUPPLY AIR SENSOR | | S52 SWITCH, AIRFLOW |
| J250 | JACK, SMOKE DETECTOR ONE | | S42 SWITCH, OVERLOAD RELAY BLOWER MOTOR |
| J251 | JACK, SMOKE DETECTOR ONE | | S86 SWITCH, DEHUMIDISTAT |
| J252 | JACK, SMOKE DETECTOR TWO | | S135 OVERLOAD, BLOWER MOTOR SUPPLY |
| J253 | JACK, SMOKE DETECTOR TWO | | S149 SWITCH, OVERFLOW ONE |
| J255 | JACK, MODULE, CONTROL SMOKE DETECTION | | S179 SWITCH, OVERFLOW TWO |
| J261 | JACK, SUPPLY SMOKE DETECTOR JUMPER | | T8 TRANSFORMER, 120 V GENERATOR POWERED |
| J262 | JACK, ECONOMIZER | | |
| J264 | JACK, BLOWER DECK | | |
| J297 | JACK, THERMOSTAT - DDC INTERFACE | | |
| J298 | JACK, IAQ INTERFACE | | |
| J299 | JACK, SAFETY INTERFACE | | |
| K27 | RELAY, TRANSFER | | |
| K55 | RELAY, BLOWER | | |
| K222 | RELAY, COMPRESSOR LOCKOUT | | |
| P26 | PLUG, AIR FLOW CONTROL | | |
| P99 | PLUG, RT16 RETURN AIR SENSOR | | |
| P100 | PLUG, RT6 SUPPLY AIR SENSOR | | |
| P250 | PLUG, SMOKE DETECTOR ONE | | |
| P251 | PLUG, SMOKE DETECTOR ONE | | |
| P252 | PLUG, SMOKE DETECTOR TWO | | |

--- DESIGNATES OPTIONAL WIRING
 - - - - - DESIGNATES CLASS II FIELD WIRING

- ▲ FOR MOTORS WITH 542 EXTERNAL OVERLOAD LESS INVERTER, SEE INVERTER WITH BY PASS FOR 542 HOOK UP
- ▲ USE S86 DEHUMIDISTAT AND K55 FOR OPTIONAL SUPERMARKET REHEAT SCHEME, PRODIGY PARAMETERS NEED TO BE MODIFIED UNDER THE SETTINGS MENU OR VIA UC SOFTWARE FOR SIMULTANEOUS HEATING AND COOLING.
- ▲ REMOTE LOCATION OF RT6
- ▲ P298-8 (DO-1) IS SERVICE RELAY OUTPUT (24VAC) IF USED CONNECT TO AN INDICATOR LIGHT
- ▲ THERMOSTAT HOOKUP FOR PROGRAMMABLE CONFIGURATION OF THE BOARD (A55).
- ▲ PRODIGY SETTINGS MUST BE MODIFIED WHEN K222, S42, S52, S149 OR S179 ARE INSTALLED
- ▲ CONNECT A172 SENSOR TO J261 ON SUPPLY AIR SMOKE DETECTOR ONLY
- ▲ S179, OVERFLOW SWITCH USED ON LGH/LCH 420-600 UNITS ONLY
- ▲ A63, A34 & A24 ARE MUTUALLY EXCLUSIVE
- ▲ FACTORY INSTALLED OPTION FOR LGH/LCH 242-600 UNITS ONLY

| | | | |
|--|--|---------------------------|--------|
| 08/17 |  | WIRING DIAGRAM | 08/17 |
| | | 537108-03 | |
| ACCESSORIES | | | |
| ELECTRONIC OR ELECTROMECHANICAL THERMOSTAT FOR ENERGENCE | | | |
| SECTION C | | | REV. 3 |
| Supersedes | | New Form No. 537108-03 | |

POWER:

1 - Terminal block P297 on the A55 Unit Controller energizes the thermostat components with 24VAC.

OPERATION:

- 2 - The A55 Unit Controller proves the optional N.O. filter switch S27 (indicates dirty filter when closed) and optional N.O. air flow switch S52 (indicates no air [i.e. broken belt] system shuts down).
- 3 - The A55 receives data from the supply and return smoke detectors A171 and A172, blower motor overload relay S42, discharge sensor RT6 and return air sensor RT16.
- 4 - The A55 receives data from the electronic thermostat A2 (Y1, Y2, W1, W2, G, OCP) and the CO₂ sensor (if economizer is used) via terminal block P297. A55 energizes the appropriate components.

ECONOMIZER

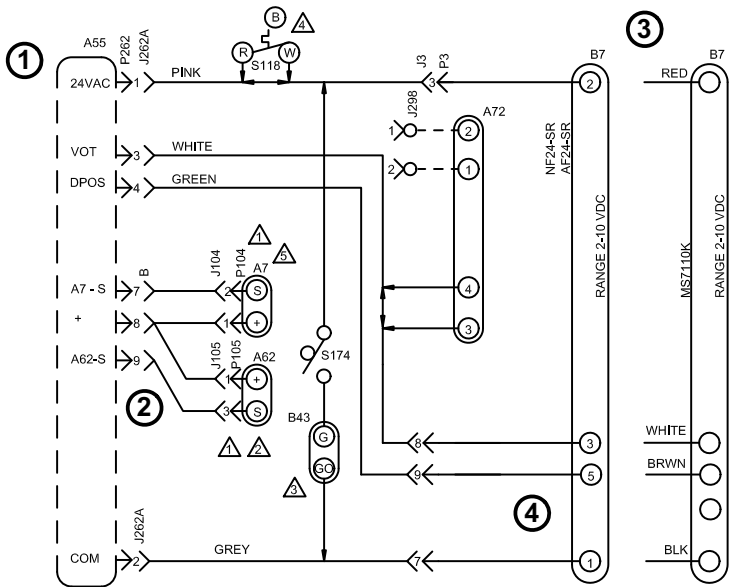

| KEY | DESCRIPTION |
|-------|----------------------------------|
| A7 | SENSOR, SOLID STATE ENTHALPY |
| A130 | CONTROL, ERS |
| A55 | CONTROL, MAIN PANEL LENNOX |
| A62 | SENSOR, ENTHALPY INDOOR |
| A72 | CONTROL, REMOTE MIN POS (OPT) |
| B7 | MOTOR, DAMPER ECONOMIZER |
| B43 | MOTOR, EXHAUST DAMPER |
| J3 | JACK, UNIT ECONOMIZER |
| J104 | JACK, SENSOR OUTDOOR ENTHALPY |
| J105 | JACK, SENSOR RETURN AIR ENTHALPY |
| J153 | JACK, ENTHALPY / DAMPER MOTOR |
| J193 | JACK, ENTHALPY SENSOR |
| J238A | JACK, IAQ INTERFACE |
| J262A | JACK, DAMPER MOTOR |
| J262B | JACK, ENTHALPY SENSORS |
| P3 | PLUG, ECONOMIZER BYPASS |
| P153 | PLUG, ENTHALPY / DAMPER MOTOR |
| P193 | PLUG, ENTHALPY SENSOR |
| P262 | PLUG, ECONOMIZER OUTPUT |
| S118 | THERMOSTAT, DESICANT DEFROST |
| S174 | SWITCH, EXHAUST DAMPER |

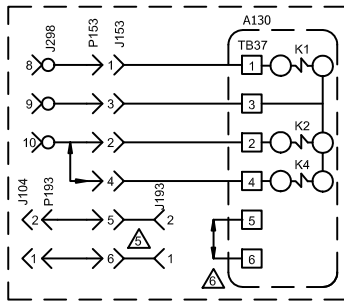

NOTE - THIS DIAGRAM USED ONLY WHEN ECONOMIZER OR MOTORIZED OUTDOOR AIR DAMPERS ARE INSTALLED.

- ⚠ DELETE A7 AND A62 (IF USED) FOR EITHER GLOBAL ENTHALPY OR SENSIBLE TEMPERATURE CONTROL
- ⚠ FOR UNIT DIFFERENTIAL ENTHALPY CONTROL, ADD A62 RETURN AIR ENTHALPY SENSOR
- ⚠ OPTIONAL EXHAUST DAMPER ACTUATOR TO HOLD EXHAUST DAMPER CLOSED WHEN OUTSIDE AIR DAMPER IS CLOSED
- ⚠ S118 USED ON 35 TO 50 TON EMERGENCE UNITS WITH ENERGY RECOVERY WHEEL (ERW)
- ⚠ REPOSITION A7 ENTHALPY SENSOR FROM ROOFTOP UNIT ECONOMIZER INTO INTAKE HOOD OF THE ERW ROOFTOP UNIT
- ⚠ REMOVE JUMPER WHEN INSTALLING OPTIONAL LOW AMBIENT SWITCH

————— DESIGNATES OPTIONAL WIRING
 - - - - - CLASS II FIELD WIRING

| | | |
|--|---------------------------|-------|
| 04/14 | WIRING DIAGRAM | 04/14 |
| 537189-01 | | |
| ACCESSORIES | | |
| EMERGENCE SERIES ECONOMIZER AND MOTORIZED OAD PIVOTING WHEEL ENERGY RECOVERY SYSTEM OPTION | | |
| SECTION D | | REV 2 |
| Supersedes | New Form No. 537189-01 | |

ECONOMIZER SEQUENCE OF OPERATION

POWER:

1 - A55 Unit Controller energizes the economizer components with 24VAC.

OPERATION:

- 2 - The A55 along with outdoor enthalpy sensor A7 and indoor enthalpy sensor A62 (if differential enthalpy is used) determine when to power the damper motor B7.
- 3 - A55 supplies B7 with 0 - 10 VDC to control the positioning of economizer.
- 4 - The damper actuator provides 2 to 10 VDC position feedback.

RSI PEB INVERTER LESS BYPASS

24V PDWER

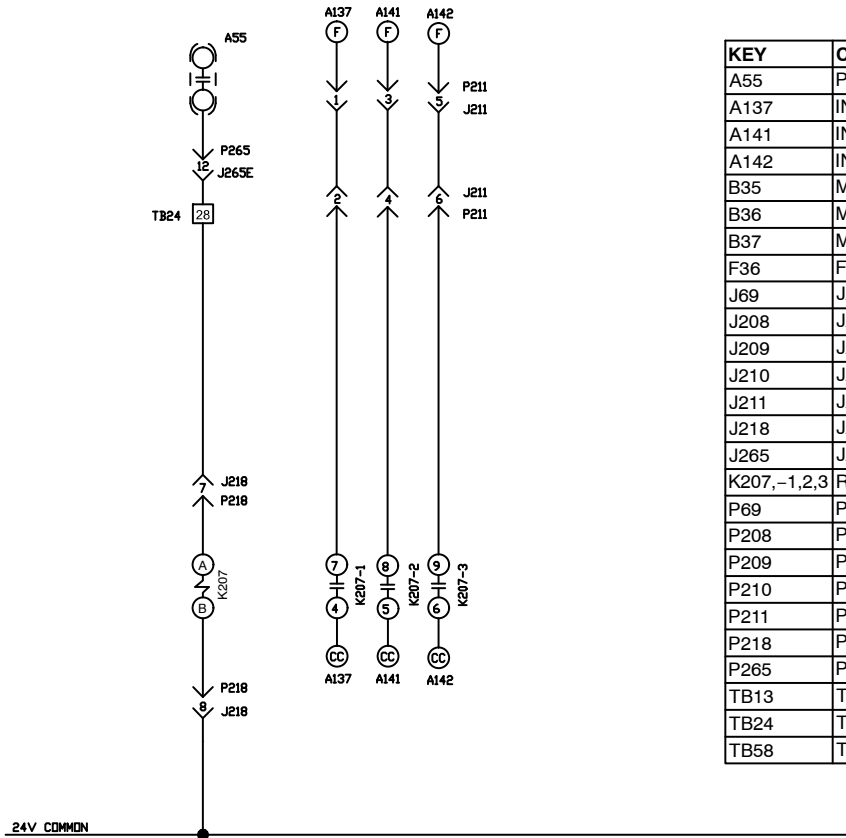

| KEY | COMPONENT |
|-------------|------------------------------------|
| A55 | PANEL, MAIN |
| A137 | INVERTER, EXHAUST 1 |
| A141 | INVERTER, EXHAUST 2 |
| A142 | INVERTER, EXHAUST 3 |
| B35 | MOTOR, EXH, BLO 1 |
| B36 | MOTOR, EXH, BLO 2 |
| B37 | MOTOR, EXH, BLO 3 |
| F36 | FUSE, INVERTER |
| J69 | JACK, INTERFACE |
| J208 | JACK, MOTOR, EXH BLO B35 |
| J209 | JACK, MOTOR, EXH BLO B36 |
| J210 | JACK, MOTOR, EXH BLO B37 |
| J211 | JACK, INVERTER EXH BLO, AUX |
| J218 | JACK, CONTROL, INVERTER |
| J265 | JACK, CONTACTORS AND RELAYS |
| K207,-1,2,3 | RELAY, EXH BLO, ADDER |
| P69 | PLUG, INTERFACE |
| P208 | PLUG, MOTOR, EXH BLO, B35 |
| P209 | PLUG, MOTOR, EXH BLO, B36 |
| P210 | PLUG, MOTOR, EXH BLO, B37 |
| P211 | PLUG, INVERTER, EXH BLO, AUX |
| P218 | PLUG, CONTROL, INVERTER |
| P265 | PLUG, CONTACTORS AND RELAYS |
| TB13 | TERMINAL STRIP, POWER DISTRIBUTION |
| TB24 | TERMINAL STRIP, UNIT ADDER |
| TB58 | TERMINAL STRIP, INVERTER |

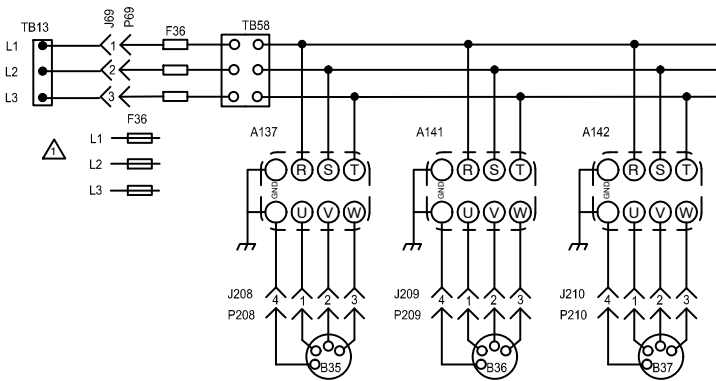

← DENOTES OPTIONAL COMPONENTS
 — LINE VOLTAGE FIELD INSTALLED NEC/CEC CLASS 1
 NOTE-ALL REMAINING WIRES FACTORY INSTALLED

⚠ SEPARATE DISCONNECT WIRING WHEN NOT FACTORY INSTALLED

| | | |
|-------------------------------------|---------------------------|-------|
| WIRING DIAGRAM | | 02/17 |
| POWER EXHAUST | | |
| RSI D BOX PEB INVERTERS LESS BYPASS | | |
| SECTION 5B | | REV 1 |
| Supersedes 534,752W | New Form No. 537376-01 | |

© 2017

Lennox Commercial

RSI PEB INVERTER WITH BYPASS

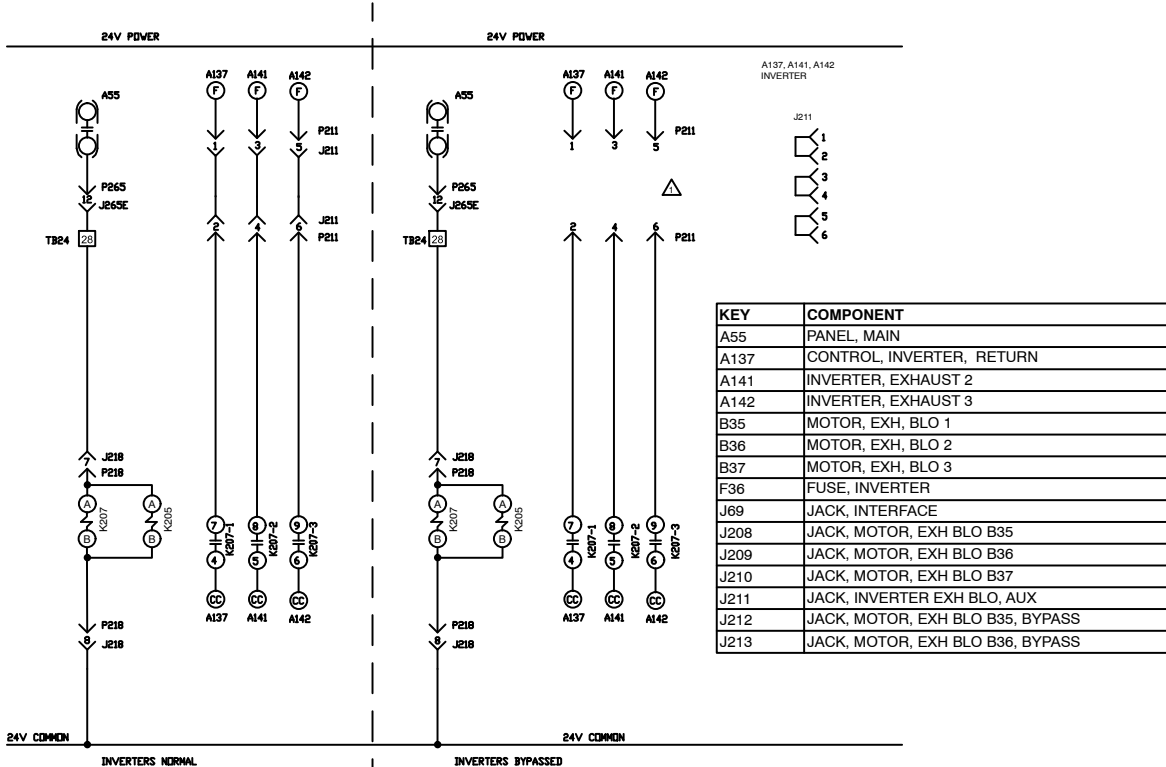

| KEY | COMPONENT |
|------|----------------------------------|
| A55 | PANEL, MAIN |
| A137 | CONTROL, INVERTER, RETURN |
| A141 | INVERTER, EXHAUST 2 |
| A142 | INVERTER, EXHAUST 3 |
| B35 | MOTOR, EXH, BLO 1 |
| B36 | MOTOR, EXH, BLO 2 |
| B37 | MOTOR, EXH, BLO 3 |
| F36 | FUSE, INVERTER |
| J69 | JACK, INTERFACE |
| J208 | JACK, MOTOR, EXH BLO B35 |
| J209 | JACK, MOTOR, EXH BLO B36 |
| J210 | JACK, MOTOR, EXH BLO B37 |
| J211 | JACK, INVERTER EXH BLO, AUX |
| J212 | JACK, MOTOR, EXH BLO B35, BYPASS |
| J213 | JACK, MOTOR, EXH BLO B36, BYPASS |

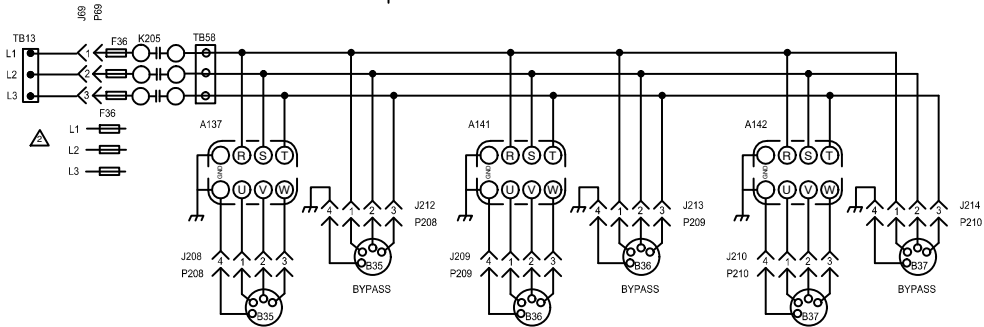

| | |
|--------------|------------------------------------|
| J214 | JACK, MOTOR, EXH BLO B37, BYPASS |
| J218 | JACK, CONTROL, INVERTER |
| J265 | JACK, CONTACTORS AND RELAYS |
| K205 | CONTACTOR, BYPASS, EXH. |
| K207, -1,2,3 | RELAY, EXH BLO, ADDER |
| P69 | PLUG, INTERFACE |
| P208 | PLUG, MOTOR, EXH BLO, B35 |
| P209 | PLUG, MOTOR, EXH BLO, B36 |
| P210 | PLUG, MOTOR, EXH BLO, B37 |
| P211 | PLUG, INVERTER, EXH BLO, AUX |
| P218 | PLUG, CONTROL, INVERTER |
| P265 | PLUG, CONTACTORS AND RELAYS |
| TB13 | TERMINAL STRIP, POWER DISTRIBUTION |
| TB24 | TERMINAL STRIP, UNIT ADDER |
| TB58 | TERMINAL STRIP, INVERTER BYPASS |

△ TO BYPASS INVERTERS, UNPLUG J211 FROM P211

△ SEPARATE DISCONNECT WIRING WHEN NOT FACTORY INSTALLED

— DENOTES OPTIONAL COMPONENTS
 — LINE VOLTAGE FIELD INSTALLED NEC/CEC CLASS 1
 NOTE-ALL REMAINING WIRES FACTORY INSTALLED

| | |
|--------------------------------------|---------------------------|
| WIRING DIAGRAM | 03/17 |
| POWER EXHAUST | |
| RSI D BOX PEB w/ INVERTERS w/ BYPASS | |
| SECTION 5B | |
| REV 1 | |
| Supersedes 534,754W | New Form No. 537377-01 |

© 2010

Lennox Commercial