

ML180UHE(X) SERIES UNITS

ML180UHE(X) series units are mid-efficiency gas furnaces used for upflow or horizontal applications only, manufactured with Lennox Duralok heat exchangers formed of aluminized steel. ML180UHE(X) units are available in heating capacities of 44,000 to 132,000 Btuh and cooling applications 2 to 5 tons. Refer to Engineering Handbook for proper sizing.

Units are factory equipped for use with natural gas. Kits are available for conversion to LP/Propane operation. ML180UHE(X) model units are equipped with a hot surface ignition system. The ML180UHE(X) unit meets the California Nitrogen Oxides (NOx) Standards and California Seasonal Efficiency requirements.

All units use a redundant gas valve to assure safety shut-off as required by C.S.A. All specifications in this manual are subject to change. Procedures outlined in this manual are presented as a recommendation only and do not supersede or replace local or state codes. In the absence of local or state codes, the guidelines and procedures outlined in this manual (except where noted) are recommended only and do not constitute code.

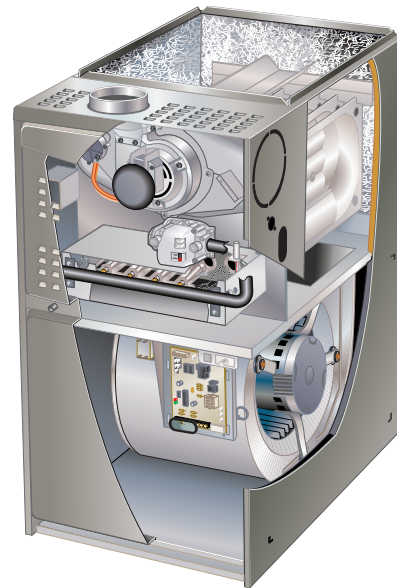

⚠ WARNING
Improper installation, adjustment, alteration, service or maintenance can cause property damage, personal injury or loss of life. Installation and service must be performed by a licensed professional HVAC installer (or equivalent), service agency or the gas supplier.

⚠ WARNING
Electric Shock Hazard. Can cause injury or death. Unit must be properly grounded in accordance with national and local codes.

Line voltage is present at all components when unit is not in operation on units with single-pole contactors. Disconnect all remote electric power supplies before opening access panel. Unit may have multiple power supplies.

TABLE OF CONTENTS

Specifications Page 2
Blower Data Page 4
Parts Identification Page 6
I Unit Components Page 7
II Installation Page 21
III Start Up Page 21
IV Heating System Service Checks Page 21
V Typical Operating Characteristics Page 26
VI Maintenance Page 26
VII Wiring and Sequence of Operation Page 29

⚠ CAUTION
As with any mechanical equipment, contact with sharp sheet metal edges can result in personal injury. Take care while handling this equipment and wear gloves and protective clothing.

SPECIFICATIONS

Gas Heating Performance		Model No.	ML180UH045E36A	ML180UH070E36A	ML180UH070E36B	ML180UH090E48B
		Model No. - Low Nox	ML180UH045XE36A	ML180UH070XE36A	ML180UH070XE36B	ML180UH090XE48B
		¹ AFUE	80%	80%	80%	80%
		Input - Btuh	44,000	66,000	66,000	88,000
		Output - Btuh	36,000	53,000	53,000	72,000
		Temperature rise range - °F	15 - 45	40 - 70	40 - 70	35 - 65
		Gas Manifold Pressure (in. w.g.) Nat. Gas / LPG/Propane	3.5 / 10.0	3.5 / 10.0	3.5 / 10.0	3.5 / 10.0
High Static - in. w.g.			0.50	0.50	0.50	0.50
Connections in.	Flue connection - in. round		4	4	4	4
	Gas pipe size IPS		1/2	1/2	1/2	1/2
Indoor Blower	Wheel nom. dia. x width - in.		10 x 8	10 x 10	10 x 10	10 x 10
	Motor Type		DC Brushless	DC Brushless	DC Brushless	DC Brushless
	Motor output - hp		1/2	1/2	1/2	3/4
	Tons of add-on cooling		1.5 - 3	1.5 - 3	1.5 - 3	2.5 - 4
	Air Volume Range - cfm		350 - 1380	625 - 1435	395 - 1415	750 - 1785
Electrical Data	Voltage		120 volts - 60 hertz - 1 phase			
	Blower motor full load amps		6.8	6.8	6.8	8.4
	Maximum overcurrent protection		15	15	15	15
Shipping Data	lbs. - 1 package		111	111	127	142

SPECIFICATIONS

Gas Heating Performance		Model No.	ML180UH090E60C	ML180UH110E60C	ML180UH135E60D
		Model No. - Low Nox	---	ML180UH110XE60C	---
		¹ AFUE	80%	80%	80%
		Input - Btuh	88,000	110,000	132,000
		Output - Btuh	72,000	90,000	107,000
		Temperature rise range - °F	30 - 60	35 - 65	30 - 60
		Gas Manifold Pressure (in. w.g.) Nat. Gas / LPG/Propane	3.5 / 10.0	3.5 / 10.0	3.5 / 10.0
High Static - in. w.g.			0.50	0.50	0.50
Connections in.	Flue connection - in. round		4	4	4
	Gas pipe size IPS		1/2	1/2	1/2
Indoor Blower	Wheel nom. dia. x width - in.		11-1/2 x 10	11-1/2 x 10	11 x 11
	Motor Type		DC Brushless	DC Brushless	DC Brushless
	Motor output - hp		1	1	1
	Tons of add-on cooling		3 - 5	3 - 5	3.5 - 5
	Air Volume Range - cfm		990 - 2290	920 - 2315	1140 - 2495
Electrical Data	Voltage		120 volts - 60 hertz - 1 phase		
	Blower motor full load amps		10.9	10.9	10.9
	Maximum overcurrent protection		15	15	15
Shipping Data	lbs. - 1 package		152	160	178

NOTE - Filters and provisions for mounting are not furnished and must be field provided.

¹ Annual Fuel Utilization Efficiency based on DOE test procedures and according to FTC labeling regulations. Isolated combustion system rating for non-weatherized furnaces.

OPTIONAL ACCESSORIES - ORDER SEPARATELY

		"A" Width Models	"B" Width Models	"C" Width Models	"D" Width Models	
CABINET ACCESSORIES						
Horizontal Suspension Kit - Horizontal only		51W10	51W10	51W10	51W10	
Return Air Base - Upflow only		65W75	50W98	50W99	51W00	
High Performance Economizer (Commercial Only)		10U53	10U53	10U53	10U53	
CONTROLS						
iComfort® M30 Smart Wi-Fi Thermostat		15Z69	15Z69	15Z69	15Z69	
Remote Outdoor Air Temperature Sensor		X2658	X2658	X2658	X2658	
Blower Relay Kit (for two-stage outdoor units)		85W66	85W66	85W66	85W66	
Furnace Twinning Kit		16W72	16W72	16W72	16W72	
FILTERS						
¹ Air Filter and Rack Kit	Horizontal (end)	87L95	87L96	87L97	87L98	
	Size of filter - in.	14 x 25 x 1	18 x 25 x 1	20 x 25 x 1	25 x 25 x 1	
	Side Return	Single	44J22	44J22	44J22	44J22
		Ten Pack	66K63	66K63	66K63	66K63
	Size of filter - in.	16 x 25 x 1	16 x 25 x 1	16 x 25 x 1	16 x 25 x 1	
NIGHT SERVICE KIT						
Night Service Kit		84W47	84W47	84W47	84W47	
VENTING						
Vent Adaptor – 6 in. conn. size upflow applications only		18M79	18M79	18M79	18M79	

¹ Cleanable polyurethane, frame-type filter.

GAS HEAT ACCESSORIES

Input	High Altitude Pressure Switch Kit			Natural Gas to LPG/Propane Kit		LPG/Propane to Natural Gas Kit	Natural Gas High Altitude Orifice Kit
	0 - 4500 ft.	4501 - 7500 ft.	7501 - 10,000 ft.	0 - 7500 ft.	7501 - 10,000 ft.	0 - 7500 ft.	7501 - 10,000 ft.
045	No Change	80W52	80W51	11K49	11K44	73W81	73W37
070	No Change	80W52	80W51	11K49	11K44	73W81	73W37
090	No Change	80W52	80W51	11K49	11K44	73W81	73W37
110	No Change	80W52	80W52	11K49	11K44	73W81	73W37
135	No Change	80W52	80W51	11K49	11K44	73W81	73W37

HIGH ALTITUDE

NOTE - Units may be installed at altitudes up to 2000 ft. above sea level without any modifications.

At altitudes above 2000 ft. units must be derated to match information in the shaded areas shown below.

NOTE - This is the only permissible derate for these units.

Input	Gas Manifold Pressure (Outlet) in. w.g.								Line Pressure - in. w.g.		
	0 - 2000 Feet		2001 - 4500 Feet		4501 - 7500 Feet		7501 - 10,000 ft.		Minimum		Maximum
	Natural Gas	LPG/Propane	Natural Gas	LPG/Propane	Natural Gas	LPG/Propane	¹ Natural Gas	LPG/Propane	Natural Gas	LPG/Propane	
045	3.5	10	3.2	10	3	10	3.5	10	4.5	11	13
070	3.5	10	3.2	10	2.8	10	3.5	10	4.5	11	13
090	3.5	10	3.2	10	2.7	9.6	3.5	10	4.5	11	13
110	3.5	10	3.5	10	3	9.6	3.5	10	4.5	11	13
135	3.5	10	3.5	10	2.9	9.6	3.5	10	4.5	11	13

¹ Natural Gas High Altitude Orifice Kit required.

BLOWER DATA

ML180UH045E36A PERFORMANCE (Less Filter)

External Static Pressure in. w.g.	Air Volume / Watts at Various Blower Speeds									
	High (Black)		Medium-High (Brown)		Medium (Blue)		Medium-Low (Yellow)		Low (Red)	
	cfm	Watts	cfm	Watts	cfm	Watts	cfm	Watts	cfm	Watts
0.00	1380	265	1155	165	995	120	975	115	945	105
0.10	1345	270	1120	175	950	120	880	105	865	100
0.20	1320	285	1080	190	900	125	805	105	700	85
0.30	1290	295	1055	200	875	135	750	110	640	90
0.40	1265	310	1010	205	825	145	710	120	595	95
0.50	1230	315	990	215	790	155	660	125	535	100
0.60	1190	330	945	230	750	165	630	135	500	110
0.70	1165	340	915	235	705	170	570	140	435	115
0.80	1130	350	880	245	670	180	535	150	380	120

ML180UH070E36A PERFORMANCE (Less Filter)

External Static Pressure in. w.g.	Air Volume / Watts at Various Blower Speeds									
	High (Black)		Medium-High (Brown)		Medium (Blue)		Medium-Low (Yellow)		Low (Red)	
	cfm	Watts	cfm	Watts	cfm	Watts	cfm	Watts	cfm	Watts
0.00	---	---	---	---	---	---	---	---	---	---
0.10	1435	282	1215	178	1120	147	1095	133	930	88
0.20	1400	290	1170	187	1090	154	1050	141	875	98
0.30	1365	303	1145	198	1055	164	1025	153	845	102
0.40	1335	311	1105	206	1015	172	985	160	795	110
0.50	1310	325	1075	216	980	177	945	169	760	117
0.60	1285	341	1040	224	950	187	905	175	705	125
0.70	1250	344	1010	235	905	196	865	183	665	129
0.80	1215	354	975	244	860	204	830	191	625	136

ML180UH070E36B PERFORMANCE (Less Filter)

External Static Pressure in. w.g.	Air Volume / Watts at Various Blower Speeds									
	High (Black)		Medium-High (Brown)		Medium (Blue)		Medium-Low (Yellow)		Low (Red)	
	cfm	Watts	cfm	Watts	cfm	Watts	cfm	Watts	cfm	Watts
0.00	---	---	---	---	---	---	---	---	---	---
0.10	1415	280	1295	170	1145	145	1130	130	955	95
0.20	1355	290	1225	185	1110	150	1080	140	885	100
0.30	1330	300	1190	200	1060	160	1035	155	825	110
0.40	1290	310	1155	205	1015	175	970	160	770	120
0.50	1245	325	1115	215	980	180	930	170	695	125
0.60	1225	335	1045	230	920	190	865	180	625	135
0.70	1190	350	1000	235	855	205	790	190	540	140
0.80	1160	365	925	245	790	205	735	200	445	145

ML180UH090E48B PERFORMANCE (Less Filter)

External Static Pressure in. w.g.	Air Volume / Watts at Various Blower Speeds									
	High (Black)		Medium-High (Brown)		Medium (Blue)		Medium-Low (Yellow)		Low (Red)	
	cfm	Watts	cfm	Watts	cfm	Watts	cfm	Watts	cfm	Watts
0.00	1785	380	1570	270	1440	220	1395	190	1190	120
0.10	1755	395	1535	275	1420	230	1350	205	1140	130
0.20	1730	415	1505	290	1380	245	1310	215	1110	145
0.30	1690	435	1460	305	1345	260	1275	230	1065	155
0.40	1645	440	1435	320	1310	270	1240	240	1010	165
0.50	1615	455	1395	335	1265	285	1180	255	955	180
0.60	1590	470	1350	350	1210	290	1150	265	915	185
0.70	1545	475	1300	360	1175	305	1095	275	860	200
0.80	N/A	N/A	1270	370	1140	310	1040	285	820	210

ML180UH090E60C PERFORMANCE (Less Filter)

External Static Pressure in. w.g.	Air Volume / Watts at Different Blower Speeds																			
	Bottom Return Air, Side Return Air from Both Sides or Return Air from Bottom and One Side.										Single Side Return Air – Air volumes in bold (over 1800 cfm) require Optional Return Air Base <u>and</u> field fabricated transition to accommodate 20 x 25 x 1 in. air filter in order to maintain proper air velocity.									
	High (Black)		Medium-High (Brown)		Medium (Blue)		Medium-Low (Yellow)		Low (Red)		High (Black)		Medium-High (Brown)		Medium (Blue)		Medium-Low (Yellow)		Low (Red)	
	cfm	Watts	cfm	Watts	cfm	Watts	cfm	Watts	cfm	Watts	cfm	Watts	cfm	Watts	cfm	Watts	cfm	Watts	cfm	Watts
0.00	2255	640	1940	420	1750	310	1580	230	1485	185	2290	655	1980	425	1775	310	1605	235	1495	195
0.10	2200	655	1910	440	1705	315	1535	240	1385	190	2250	675	1945	445	1730	320	1555	245	1400	190
0.20	2150	675	1865	450	1655	340	1490	260	1340	205	2210	695	1885	465	1680	340	1510	265	1350	205
0.30	2125	695	1835	475	1635	355	1450	275	1285	215	2165	715	1850	475	1645	355	1470	275	1285	215
0.40	2090	715	1800	495	1585	370	1405	285	1235	230	2135	720	1810	490	1595	370	1410	290	1225	230
0.50	2060	735	1760	510	1545	385	1370	305	1200	245	2070	735	1765	515	1545	390	1370	305	1180	245
0.60	2020	750	1725	525	1515	405	1320	320	1145	255	2030	760	1715	530	1495	405	1325	320	1140	255
0.70	1980	765	1680	540	1465	420	1265	330	1105	270	1990	775	1685	540	1450	425	1265	330	1095	270
0.80	1935	785	1635	560	1420	435	1225	350	1055	285	1950	795	1645	560	1415	435	1225	345	1040	285

ML180UH110E60C PERFORMANCE (Less Filter)

External Static Pressure in. w.g.	Air Volume / Watts at Different Blower Speeds																			
	Bottom Return Air, Side Return Air with Return Air from Both Sides or Return Air from Bottom and One Side.										Single Side Return Air – Air volumes in bold (over 1800 cfm) require Optional Return Air Base <u>and</u> field fabricated transition to accommodate 20 x 25 x 1 in. air filter in order to maintain proper air velocity.									
	High (Black)		Medium-High (Brown)		Medium (Blue)		Medium-Low (Yellow)		Low (Red)		High (Black)		Medium-High (Brown)		Medium (Blue)		Medium-Low (Yellow)		Low (Red)	
	cfm	Watts	cfm	Watts	cfm	Watts	cfm	Watts	cfm	Watts	cfm	Watts	cfm	Watts	cfm	Watts	cfm	Watts	cfm	Watts
0.00	2230	635	1945	430	1715	295	1555	230	1470	185	2315	645	1990	415	1780	300	1610	230	1510	200
0.10	2180	655	1905	445	1690	305	1510	240	1340	175	2260	655	1945	425	1740	315	1550	240	1400	185
0.20	2135	680	1865	465	1630	330	1470	260	1280	190	2210	680	1895	450	1680	335	1510	255	1350	200
0.30	2090	695	1830	480	1595	345	1440	275	1235	200	2165	700	1850	465	1650	355	1455	275	1285	210
0.40	2050	715	1785	495	1550	360	1385	285	1175	210	2130	715	1830	485	1585	365	1395	285	1230	225
0.50	2025	730	1740	520	1500	375	1340	300	1130	225	2095	730	1770	500	1535	385	1365	300	1175	235
0.60	2010	750	1710	535	1470	390	1305	320	1080	240	2055	755	1725	515	1495	400	1305	315	1135	250
0.70	1965	755	1670	555	1420	410	1255	330	1015	255	2000	765	1675	535	1465	410	1255	325	1080	265
0.80	1905	785	1635	560	1380	425	1215	350	975	270	1965	785	1640	555	1400	425	1210	345	1025	275

ML180UH135E60D PERFORMANCE (Less Filter)

External Static Pressure in. w.g.	Air Volume / Watts at Different Blower Speeds																			
	Bottom Return Air, Side Return Air with Return Air from Both Sides or Return Air from Bottom and One Side.										Single Side Return Air – Air volumes in bold (over 1800 cfm) require Optional Return Air Base <u>and</u> field fabricated transition to accommodate 20 x 25 x 1 in. air filter in order to maintain proper air velocity.									
	High (Black)		Medium-High (Brown)		Medium (Blue)		Medium-Low (Yellow)		Low (Red)		High (Black)		Medium-High (Brown)		Medium (Blue)		Medium-Low (Yellow)		Low (Red)	
	cfm	Watts	cfm	Watts	cfm	Watts	cfm	Watts	cfm	Watts	cfm	Watts	cfm	Watts	cfm	Watts	cfm	Watts	cfm	Watts
0.00	2495	755	2295	590	2045	435	1845	315	1650	230	2365	725	2295	575	2005	410	1820	300	1635	235
0.10	2440	780	2220	620	2015	445	1820	330	1615	245	2350	745	2210	595	2000	435	1745	320	1530	230
0.20	2390	790	2175	640	1935	470	1735	350	1550	255	2330	775	2175	625	1945	455	1730	330	1490	250
0.30	2360	805	2140	655	1895	490	1720	370	1485	275	2245	785	2135	645	1895	475	1655	355	1425	265
0.40	2285	835	2125	675	1850	510	1660	380	1455	290	2215	810	2085	660	1840	495	1600	375	1385	285
0.50	2240	860	2060	690	1815	535	1610	400	1415	310	2175	825	2045	680	1815	505	1590	390	1340	290
0.60	2225	865	2015	715	1785	550	1535	420	1330	320	2125	845	1995	700	1765	530	1525	405	1300	310
0.70	2160	895	1955	735	1755	570	1500	440	1265	340	2095	865	1950	710	1700	545	1485	420	1260	325
0.80	2105	905	1925	750	1715	580	1435	450	1215	345	2065	880	1890	725	1680	565	1415	445	1205	345

PARTS ARRANGEMENT

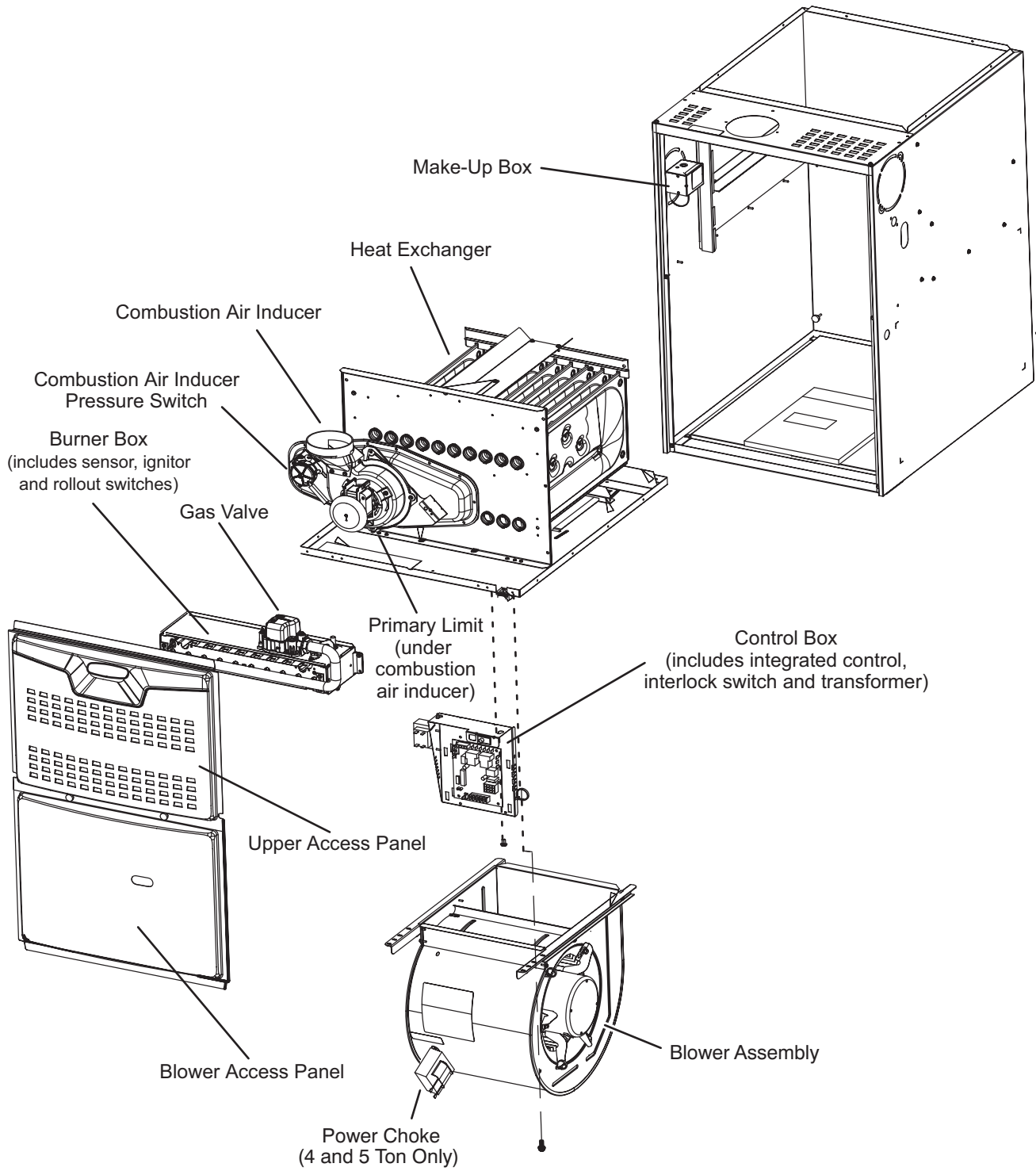

FIGURE 1

I-UNIT COMPONENTS

ML180UHE(X) unit components are shown in figure 1. The gas valve, combustion air inducer and burners can be accessed by removing the upper access panel. Electrical components are in the control box (figure 2) found in the blower section.

ELECTROSTATIC DISCHARGE (ESD) Precautions and Procedures



1. Control Transformer (T1)

A transformer located in the control box provides power to the low voltage section of the unit. Transformers on all models are rated 40VA with a 120V primary and a 24V secondary.

2. Door Interlock Switch (S51)

A door interlock switch rated 14A at 125VAC is wired in series with line voltage. When the blower door is removed the unit will shut down.

NOTE - The door interlock switch is a safety switch. Do not by-pass or jumper switch.

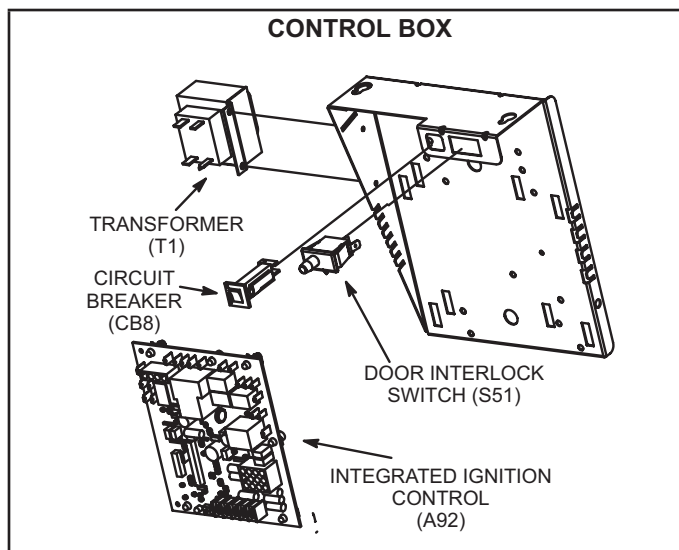

FIGURE 2

3. Circuit Breaker (CB8)

A 24V circuit breaker is also located in the control box. The switch provides overcurrent protection to the transformer (T1). The breaker is rated at 3A at 32V. If the current exceeds this limit the breaker will trip and all unit operation will shutdown. The breaker can be manually reset by pressing the button on the face.

4. Integrated Control (A92)

⚠ WARNING

Shock hazard.

Disconnect power before servicing. Control is not field repairable. If control is inoperable, simply replace entire control.

Can cause injury or death. Unsafe operation will result if repair is attempted.

The hot surface ignition control system consisting of an integrated control (figure 3 with control terminal designations in tables 1, 2 and 3), sensor and ignitor (figure 6). The integrated control and ignitor work in combination to ensure furnace ignition and ignitor durability. The integrated control, controls all major furnace operations. The integrated control also features a RED LED for troubleshooting and two accessory terminals rated at (1) one amp. See table 4 or 5. for troubleshooting diagnostic codes. The nitride ignitor is made from a non-porous, high strength proprietary ceramic material that provides long life and trouble free maintenance.

Electronic Ignition (Figure 4)

On a call for heat the integrated control monitors the combustion air inducer pressure switch. The control will not begin the heating cycle if the pressure switch is closed (bypassed). Once the pressure switch is determined to be open, the combustion air inducer is energized. When the differential in the pressure switch is great enough, the pressure switch closes and a 15-second pre-purge begins. If the pressure switch is not proven within 2-1/2 minutes, the integrated control goes into Watchguard-Pressure Switch mode for a 5-minute re-set period.

After the 15-second pre-purge period, the ignitor warms up for 20 seconds during which the gas valve opens at 19 seconds for a 4-second trial for ignition. The ignitor remains energized for the first 3 seconds during the 4 second trial. If ignition is not proved during the 4-second period, the integrated control will try four more times with an inter-purge and warm-up time between trials of 35 seconds. After a total of five trials for ignition (including the initial trial), the integrated control goes into Watchguard-Flame Failure mode. After a 60-minute reset period, the integrated control will begin the ignition sequence again.

TABLE 1

4-Pin Terminal Designation	
PIN #	FUNCTION
1	Combustion Air Inducer Line
2	Ignitor Line
3	Combustion Air Inducer Neutral
4	Ignitor Neutral

TABLE 2

12-Pin Terminal Designations	
PIN #	FUNCTION
1	High Limit Output
2	Not Used
3	24V Line
4	Not Used
5	Rollout Switch Out
6	24V Neutral
7	High Limit Input
8	Ground
9	Gas Valve Common
10	Pressure Switch In
11	Rollout Switch In
12	Gas Valve Out

TABLE 3

1/4" Quick Connect Terminals	
120HUM	Humidifier 120VAC
LINE	120VAC
XFMR	Transformer 120VAC
CIRC	Indoor blower 120VAC
EAC	Indoor air quality accessory 120VAC
NEUTRALS	Common 120VAC
HUM24	Humidifier 24VAC
3/16" Quick Connect Terminals	
COOL	Cooling tap 24VAC
HEAT	Heating tap 24VAC
FAN	Continuous blower 24 VAC
PARK (no power)	Park terminal for speed taps
FS	Flame sense
24 COM	Common 24VAC

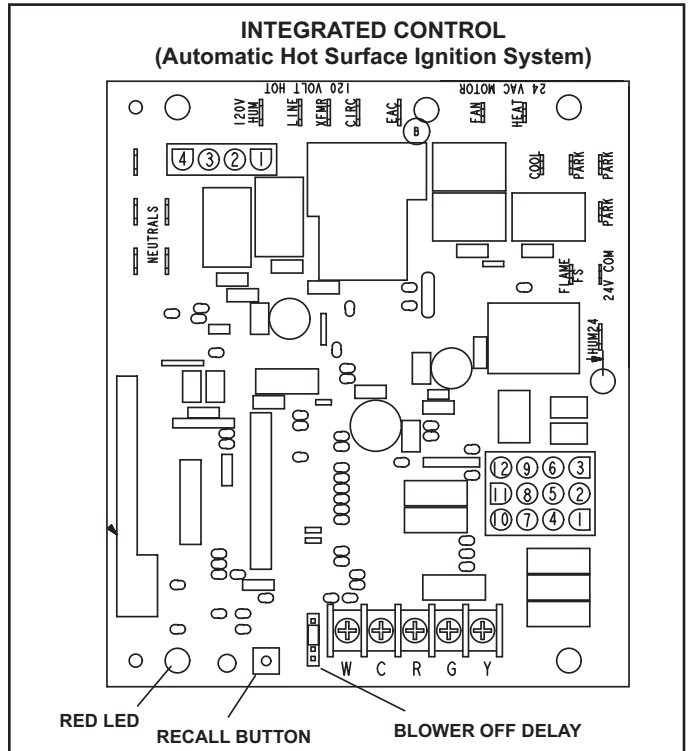

FIGURE 3

TABLE 4

(-02 integrated Control)

RED LED Flash Code²	Diagnostic Codes / Status of Furnace
Off	No power to control or board fault detected
Heartbeat ¹	Normal Operation - Idle, Continuous Fan, Cool
1	Reverse Line Voltage Polarity
2	Improper Earth Ground
3	Burner failed to light, or lost flame during heat demand
4	Low Flame Signal - check flame sensor
5	Watchguard - burner failed to light, exceeded maximum number of retries or recycles.
6	Ignitor Circuit Failure - not available on this control
7	Primary or Secondary Limit Open or Watchguard Mode - Limit Switch Open longer than 3 minutes
8	Rollout Switch Open
9	Pressure Switch failed to close or opened during heat demand
10	Watchguard - Pressure Switch opened 5 times during one heat demand
11	Pressure Switch stuck closed prior to activation of combustion air inducer
12	Flame Sensed without gas valve energized
13	Low Line Voltage
Notes	
Note 1	A "Heartbeat" is indicated by a "Slow Flash" - 1 sec on 1 sec off, repeating
Note 2	Error codes are indicated by a "rapid flash" - the LED flashes X times at ½ second on ½ second off, remains off for 3 seconds then repeats.
Note3	Last 10 error codes are stored in memory including when power is shut off to the unit. - To recall, press and release button, most recent will be displayed first, LED off for 3 sec, then next error code is displayed, etc. To clear error codes, depress and hold button longer than 5 seconds.

TABLE 5
(-03 Integrated Control)

RED LED Flash Code ²	Diagnostic Codes / Status of Furnace
Off	No power to control or board fault detected
Heartbeat ¹	Normal Operation - Idle, Continuous Fan, Cool
Continuous Rapid Flash	Call For Heat / Burner Operation
1	Reverse Line Voltage Polarity
2	Improper Earth Ground
3	Burner failed to light, or lost flame during heat demand
4	Low Flame Signal - check flame sensor
5	Watchguard - burner failed to light, exceeded maximum number of retries or recycles.
6	Not Used
7	Primary or Secondary Limit Open or Watchguard Mode - Limit Switch Open longer than 3 minutes
8	Rollout Switch Open
9	Pressure Switch failed to close or opened during heat demand
10	Watchguard - Pressure Switch opened 5 times during one heat demand
11	Pressure Switch stuck closed prior to activation of combustion air inducer
12	Flame Sensed without gas valve energized
13	Low Line Voltage
Notes	
Note - 1	A "Heartbeat" is indicated by a "Slow Flash" - 1 sec on 1 sec off, repeating
Note - 2	Error codes are indicated by a "rapid flash" - the LED flashes X times at ½ second on ½ second off, remains off for 3 seconds then repeats.
Note - 3	Last 10 error codes are stored in memory including when power is shut off to the unit. - To recall, press and release button, most recent will be displayed first, LED off for 3 sec, then next error code is displayed, etc. To clear error codes, depress and hold button longer than 5 seconds.

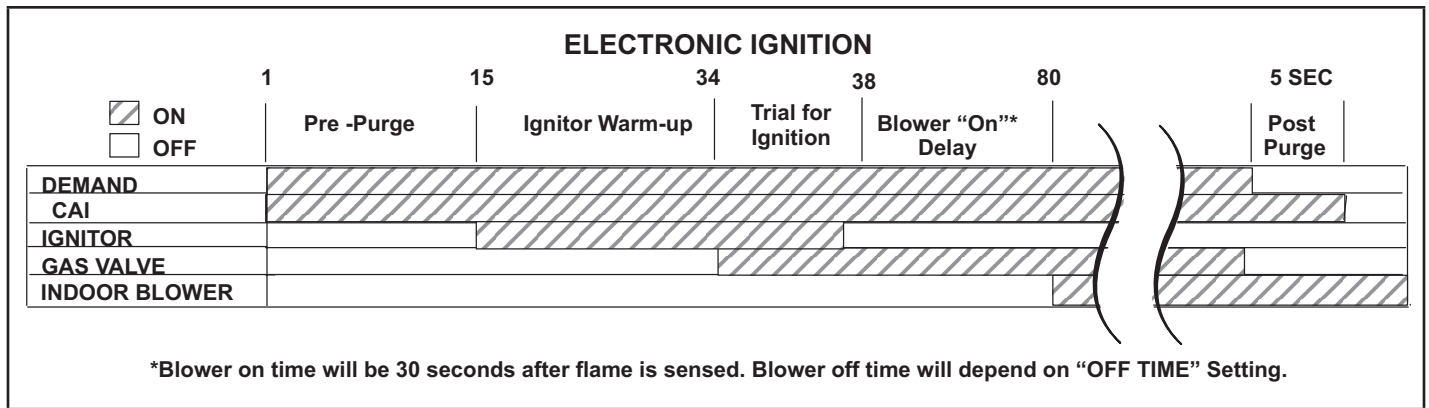

FIGURE 4

Fan Time Control

Heating Fan On Time

The fan on time of 30 seconds is not adjustable.

Heating Fan Off Time

Fan off time (time that the blower operates after the heat demand has been satisfied) can be adjusted by moving the jumper to a different setting. The unit is shipped with a factory fan off setting of 90 seconds. For customized comfort, monitor the supply air temperature once the heat demand is satisfied. Note the supply air temperature at the instant the blower is de-energized.

Adjust the fan-off delay to achieve a supply air temperature between 90° - 110° at the instant the blower is de-energized. (Longer delay times allow for lower air temperature, shorter delay times allow for higher air temperature). See figure 5.

Cooling Fan On Time

The fan on time is 2 seconds and is not adjustable.

Cooling Fan Off Time

The control has a 45 second fan off delay after cooling demand has been met. This delay is factory set and not adjustable.

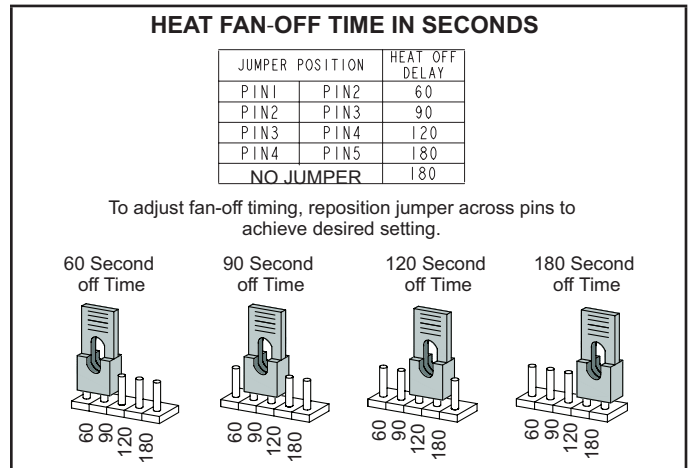

FIGURE 5

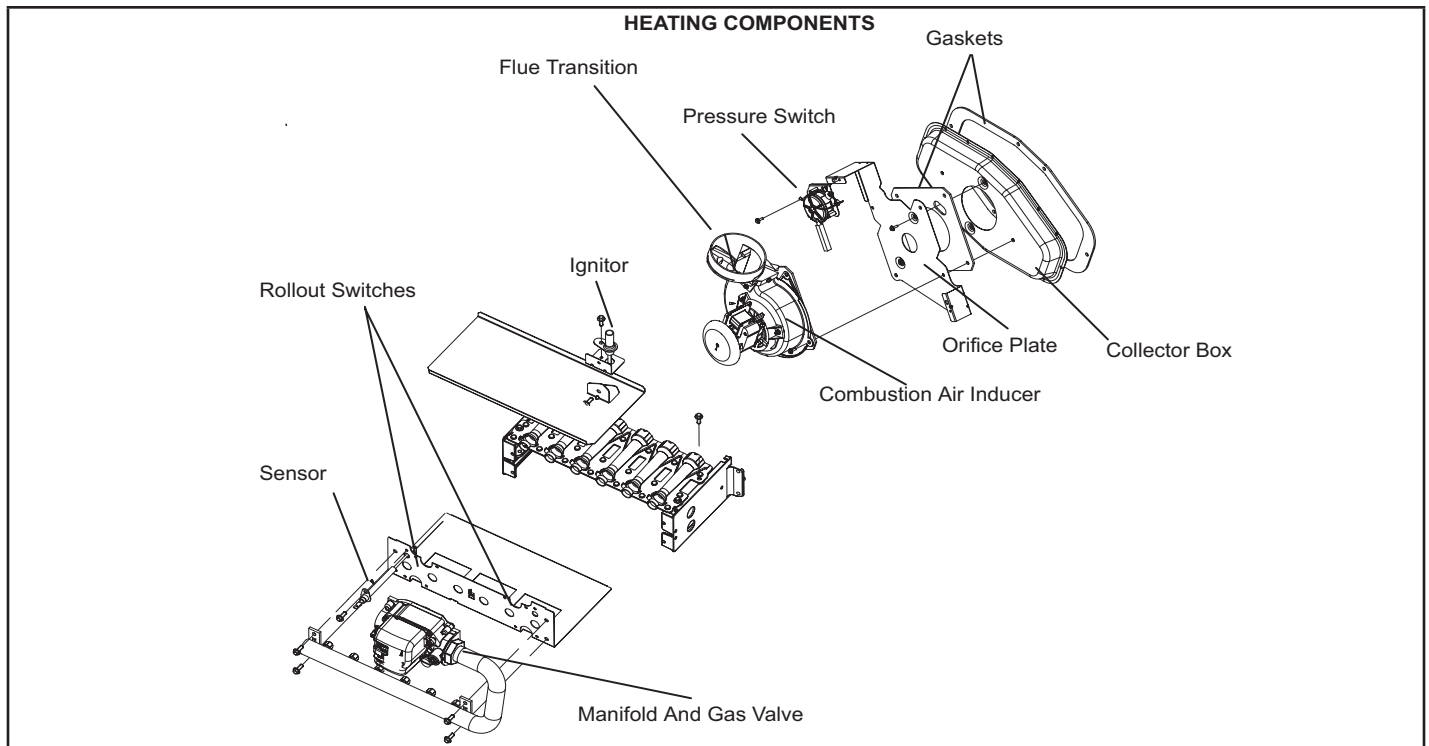

FIGURE 6

5. Flame Rollout Switches (Figure 6)

Flame rollout switch (S47) is a high temperature limit. Each furnace is equipped with two identical switches. The limit is a N.C. SPST manual-reset limit connected in series with the integrated control A92. When S47 senses rollout, the integrated control immediately stops ignition and closes the gas valve. If unit is running and flame rollout is detected, the gas valve will close and integrated control will be disabled. Rollout can be caused by a blocked heat exchanger, blocked flue or lack of combustion air. The switch has a factory setpoint of 210°F and cannot be adjusted. To manually reset a tripped switch, push the reset button located on the control.

6. Primary Limit Control

The primary limit on ML180UHE(X) units is located in the heating vestibule panel under the combustion air inducer. See figure 7. When excess heat is sensed in the heat exchanger, the limit will open. If the limit is open, the integrated control energizes the supply air blower and closes the gas valve. The limit automatically resets when unit temperature returns to normal.

The switch must reset within three minutes or SureLight® control will go into Watchguard for one hour. The switch is factory set and cannot be adjusted. The switch may have a different setpoint for each unit model number. If limit switch must be replaced, refer to Lennox ProductZone repair parts list.

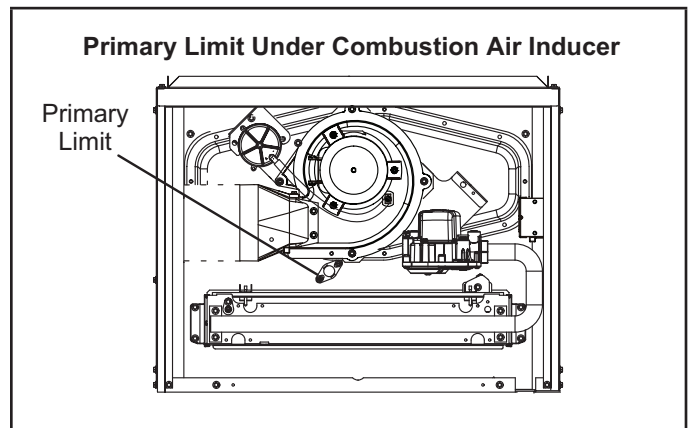

FIGURE 7

7. Flame Sensor (Figure 6)

A flame sensor is located on the left side of the burner support. The sensor is mounted on the flame rollout plate and the tip protrudes into the flame envelope of the left-most burner. The sensor can be removed for service (clean with steel wool) without removing any part of the burners. During operation, flame is sensed by current passed through the flame and sensing electrode. The integrated control allows the gas valve to remain open as long as flame signal is sensed.

A microamp DC meter is needed to check the flame signal on the integrated control.

Flame (microamp) signal is an electrical current which passes from the integrated control to the sensor during unit operation. Current passes from the sensor through the flame to ground to complete a safety circuit.

To Measure Flame Signal - Integrated Control:

Use a digital readout meter capable of reading DC microamps.

See figure 8 and table 6 for flame signal check.

- 1 - Set the meter to the DC amps scale.
- 2 - Turn off supply voltage to control.
- 3 - Remove sensor wire from integrated control.

- 4 - Connect (-) lead to flame sensor wire.
- 5 - Connect (+) lead to Terminal FS on integrated control.
- 6 - Turn supply voltage on and close thermostat contacts to cycle system.
- 7 - When main burners are in operation for two minutes, take reading.

TABLE 6

Flame Signal in Microamps		
Normal	Low	Drop Out
1.5 or greater	0.5 - 1.4	0.4 or less

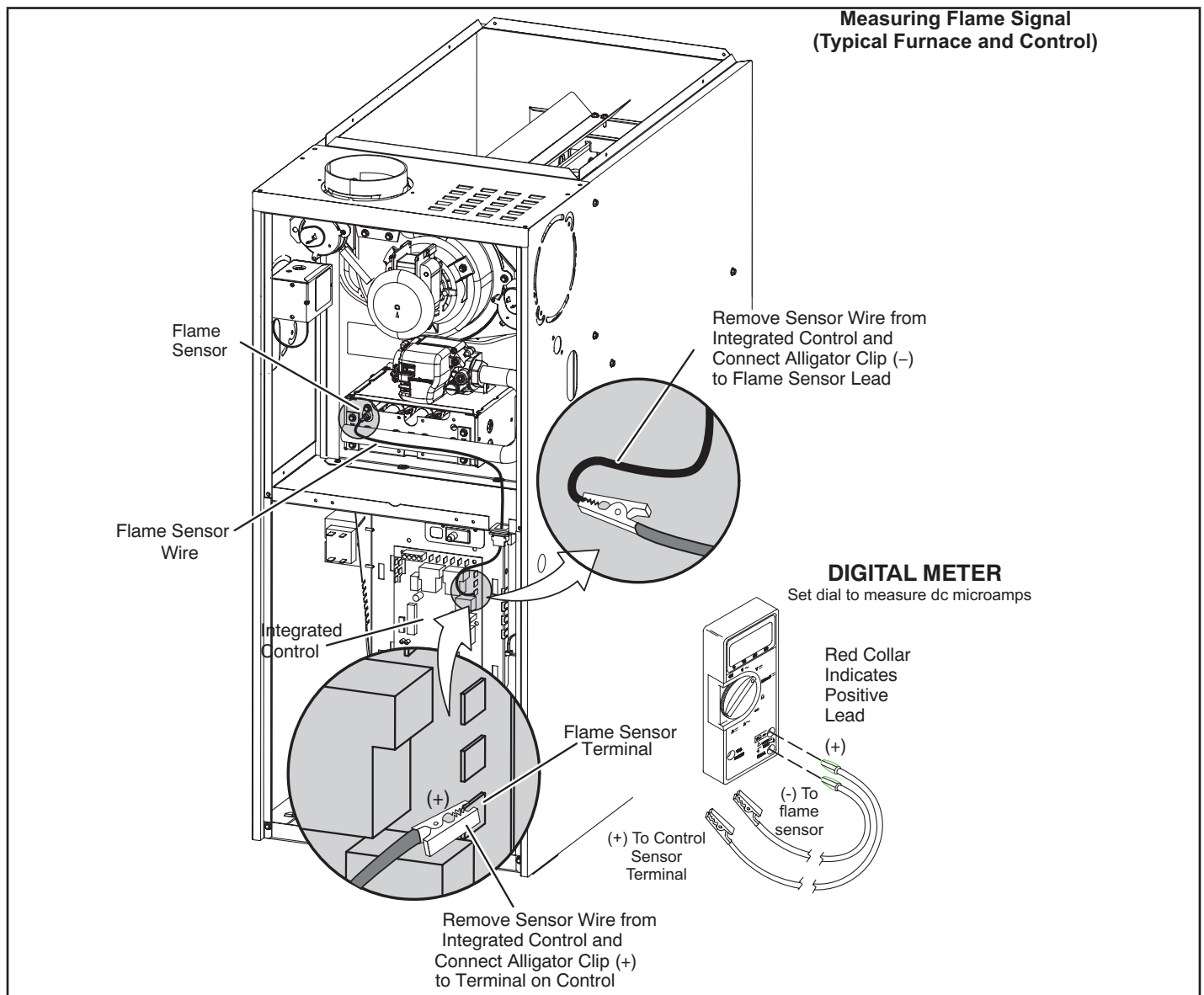

FIGURE 8

8. Gas Valve (Figure 6)

The ML180UHE(X) uses an internally redundant gas valve to assure safety shut-off. If the gas valve must be replaced, the same type valve must be used. 24VAC terminals and valve switch are located on the valve. All terminals on the gas valve are connected to wires from the integrated control. 24V applied to the terminals energizes the valve.

Inlet and outlet pressure taps are located on the valve. A regulator adjustment screw is located on the valve. LPG changeover kits are available from Lennox. Kits include burner orifices and a gas valve regulator spring.

9. Combustion Air Inducer (B6)

All ML180UHE(X) units use a combustion air inducer to move air through the burners and heat exchanger during heating operation. The blower uses a 120VAC motor. The motor operates during all heating operation and is controlled by integrated control A92. The inducer also operates for 15 seconds before burner ignition (pre-purge) and for 5 seconds after the gas valve closes (post-purge). A pressure switch mounted on the combustion air inducer orifice plate is used to prove inducer operation. The combustion air inducer orifice will be different for each model.

See table 7 for orifice sizes. The switch monitors air pressure in the inducer housing. During normal operation, the pressure in the housing is negative. If pressure becomes less negative (signifying any obstruction in the flue) the pressure switch opens. When the pressure switch opens, the integrated control (A92) immediately de-energizes the gas valve to prevent burner operation.

TABLE 7

Model	C.A.I. Orifice Size
045E36A	1.063"
070E36B	1.316"
090E48B, 090E60C	1.531"
110E60C	1.690"
135E60D	1.940"

10. Ignitor (Figure 6)

The nitride ignitor used on ML180UHE units is made from a proprietary ceramic material. To check ignitor, measure its resistance and voltage. A value of 39 to 70 ohms indicates a good ignitor. Voltage to the ignitor should be 120VAC. See figure 9 for resistance, and voltage check.

NOTE - The ML180UHE(X) furnace contains electronic components that are polarity sensitive. Make sure that the furnace is wired correctly and is properly grounded.

IGNITOR CHECKS

Test 1

Check ignitor circuit for correct resistance.

Remove 4-pin plug from control.
Check ohms reading across terminals 2 and 4.
The reading should be between 39 and 70 ohms. If value is correct, this is the only test needed. If the reading on the meter is not correct, (0 or infinity) then a second test is needed.

Meter
(set to ohms)

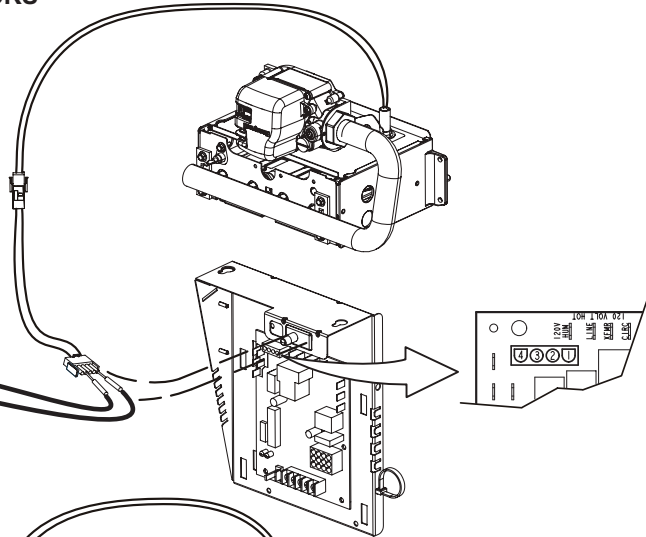
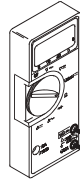

Test 2

Check ignitor for correct resistance.

Separate the 2-pin jack-plug near the manifold and check resistance of ignitor at the plug. Reading should be between 39 and 70 ohms. If the reading is correct, then the problem is with the wiring between the jack-plug and the control. If reading is not correct, the issue is the ignitor.

Meter
(set to ohms)

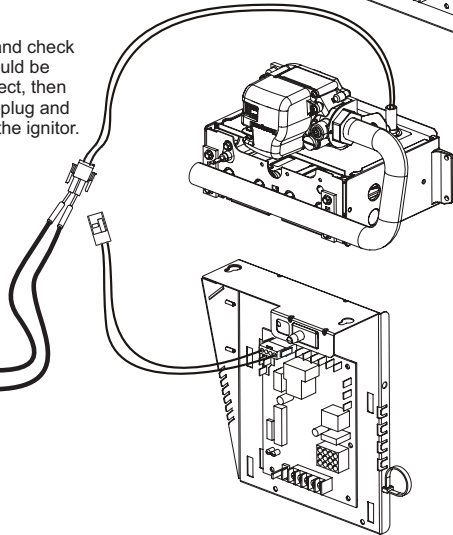
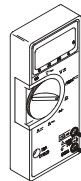

Test 3

Check ignitor for correct voltage

Insert meter probes into terminals 2 and 4 (use small diameter probes in order not to damage plug).
Check voltage during 20 second ignitor warm up period.
Voltage should read 120 volts \pm 10%. If voltage reads below these values, check for correct supply voltage to furnace.

Meter
(set to ohms)

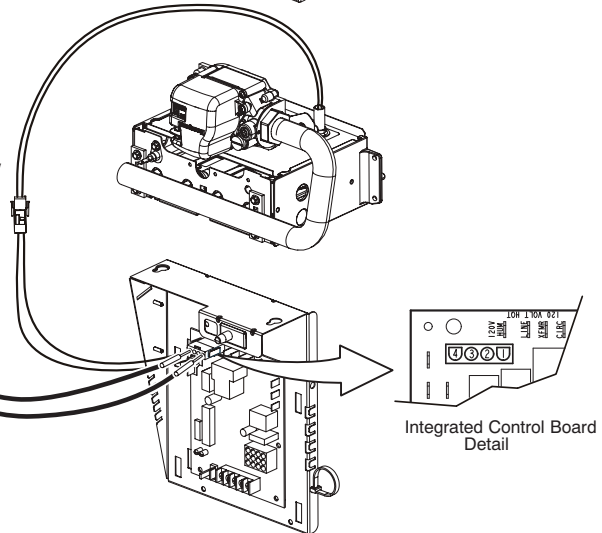
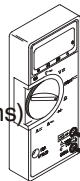

FIGURE 9

11. Combustion Air Inducer Pressure Switch (S18)

ML180UHE(X) series units are equipped with a combustion air pressure switch located on the combustion air inducer orifice bracket. The switch is connected to the combustion air inducer housing by means of a flexible silicone hose. It monitors negative air pressure in the combustion air inducer housing.

The switch is a single-pole single-throw proving switch electrically connected to the furnace control. The purpose of the switch is to prevent burner operation if the combustion air inducer is not operating or if the flue becomes obstructed.

On start-up, the switch senses that the combustion air inducer is operating. It closes a circuit to the integrated control when pressure inside the combustion air inducer decreases to a certain set point. Set points vary depending on unit size. See table 8. The pressure sensed by the switch is negative relative to atmospheric pressure. If the flue becomes obstructed during operation, the switch senses a loss of negative pressure (pressure becomes more equal with atmospheric pressure) and opens the circuit to the integrated control and gas valve. A bleed port on the switch allows relatively dry air in the vestibule to purge switch tubing, to prevent condensate build up.

TABLE 8

Unit	inches wc	
	Make	Break \pm 0.05
045E36A-1, -2, -54	-0.75	-0.65
070E36B-1, -2	-0.83	-0.68
070E36B-54	-0.85	-0.70
090E48B, 090E60C-1, -2	-0.80	-0.65
090E48B-54	-0.85	-0.70
110E60C-1, -2	-0.83	-0.68
110E60C-54	-0.85	-0.70
135E60D-1, -2, -54	-0.80	-0.65

The switch is factory set and is not field adjustable. It is a safety shut-down control in the furnace and must not be bypassed for any reason. If switch is closed or by-passed, the integrated control will not initiate ignition at start up.

Troubleshooting

See figure 10 for measuring operating pressure and checking resistance in the pressure switch.

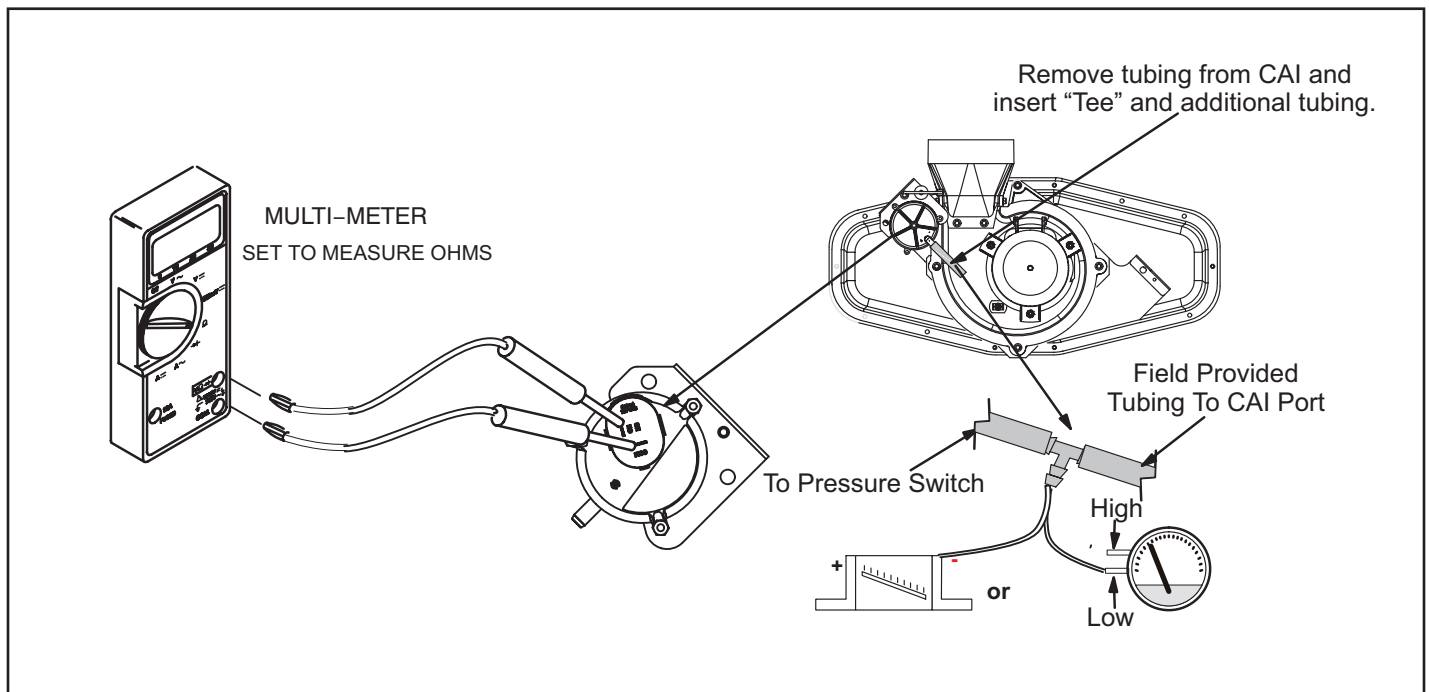

FIGURE 10

Multiple Venting

The ML180UHE(X) furnace can vent in multiple positions. See figure 11. The make up box may be removed and the combustion air inducer may be rotated clockwise or counterclockwise 90° to allow for vertical or horizontal vent discharge in a vertical or horizontal cabinet position.

Remove the four mounting screws, rotate the assembly (assembly consists of orifice plate, proving switch, gasket and combustion air inducer), then reinstall the mounting screws. See unit Installation Instructions for more detail.

! IMPORTANT

The combustion air pressure switch must be moved for horizontal discharge air left position.

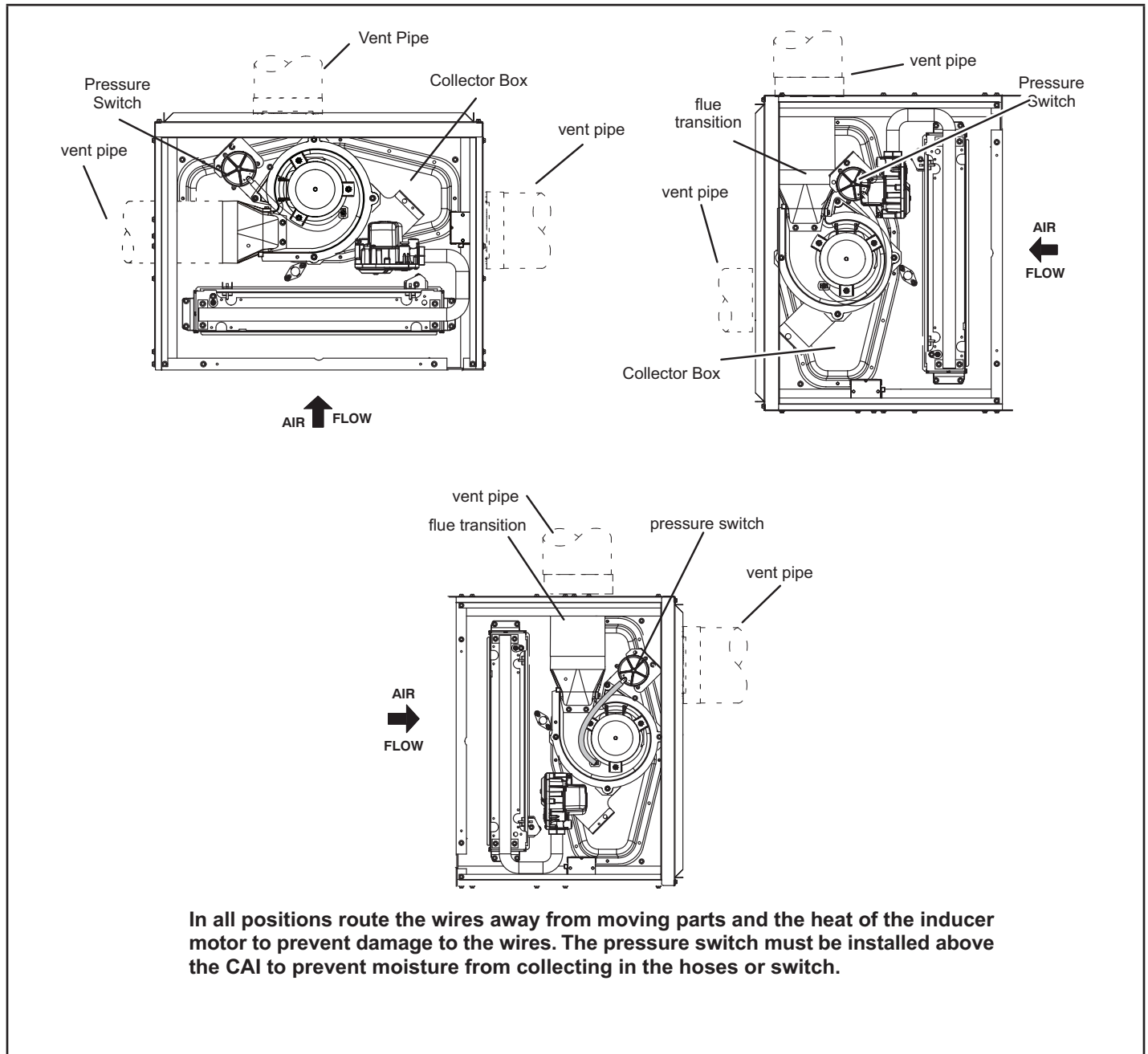

FIGURE 11

12. Blower Motor

! IMPORTANT

Each blower is statically and dynamically balanced as an assembly before installation in the unit.

ML180UHE units are equipped with a constant torque ECM motor. It has a DC motor coupled to an electronic control module both contained in the same motor housing. The motor is programmed to provide constant torque at each of the five selectable speed taps. Each tap requires 24 volts to energize.

Input Voltage Requirements

The circuit is designed to be operated with AC voltage. To enable a tap requires 12 to 33VAC. Expected current draw will be less than 20mA.

Troubleshooting

Troubleshooting the motor is an easy process. Follow steps below.

- 1 - Shut off power to unit.
- 2 - Remove input plugs P48 and P49 from motor. See figure 14 for troubleshooting procedure.

If correct voltage is present in tests 1 and 2 and motor is not operating properly, replace motor. The motor is not field repairable.

If replacing the indoor blower motor or blower wheel is necessary, placement is critical. The blower wheel must be centered in the blower housing as shown in figure 12. When replacing the indoor blower motor the set screw must be aligned and tightened with the motor shaft as shown in figure 13.

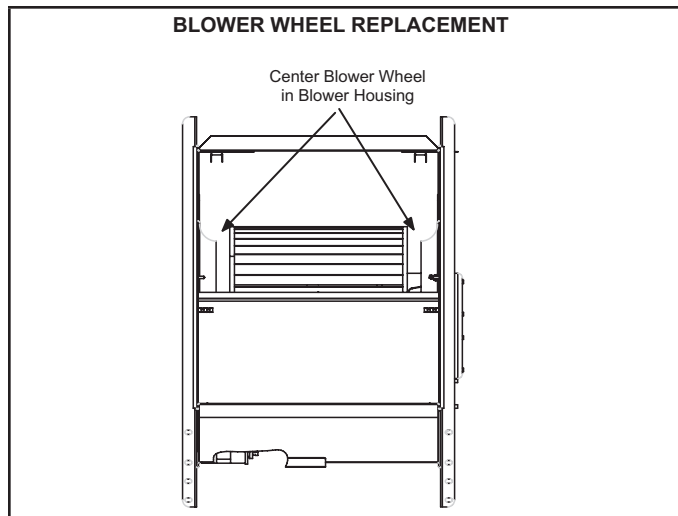

FIGURE 12

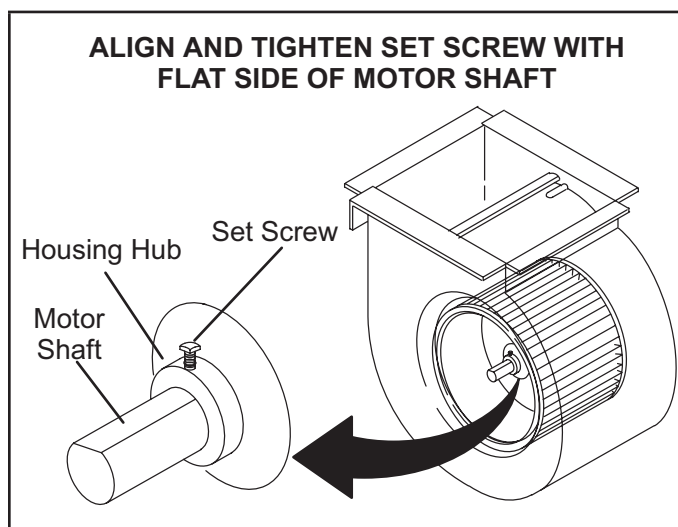
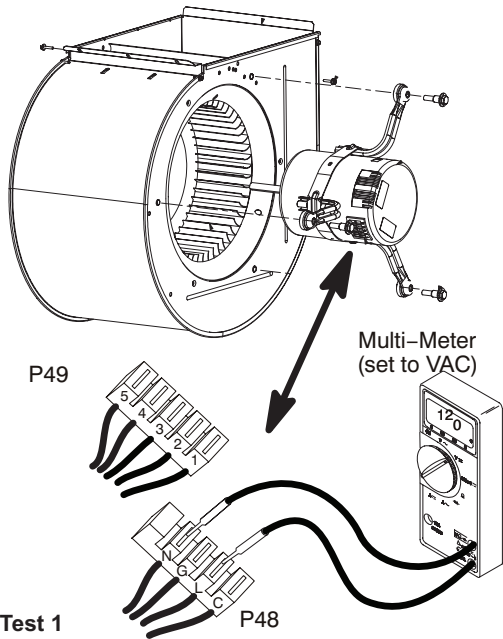
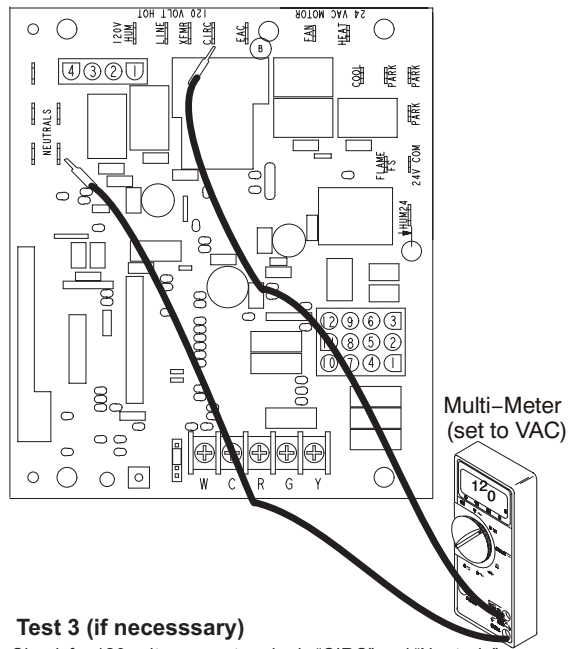

FIGURE 13



Test 1

Turn on power to unit. Check for 120 volts across terminals "L" and "N" on input plug P48. If voltage is present continue to test 2. If voltage is not present problem may be upstream of plug P48 and proceed to test 3.



Test 3 (if necessary)

Check for 120 volts across terminals "CIRC" and "Neutrals" on the integrated control. If voltage is present, problem is with the harness. If voltage is not present problem may be with the integrated control.

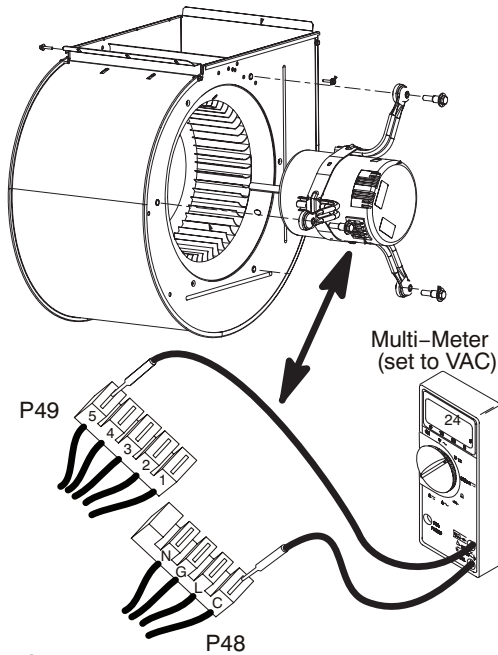

Test 2

Switch thermostat to CONTINUOUS FAN MODE. Check for 24 volts across terminal "C" on input plug P48 and speed tap used for continuous fan. (1, 2, 3, 4 or 5) on input plug P49. If 24 volts is not present problem may be upstream of plug P49. Proceed to test 4.

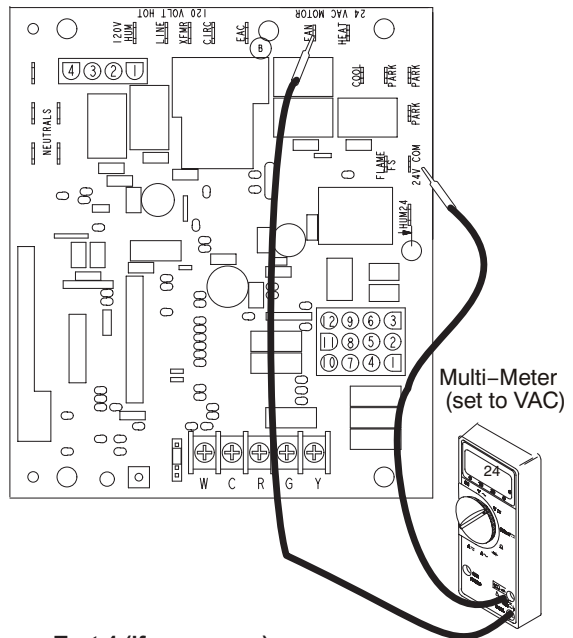

Test 4 (if necessary)

Check for 24 volts across terminals "24 COM" and "FAN" terminals on the integrated control. If voltage is present, problem is with the harness. If voltage is not present problem may be with the integrated control.

FIGURE 14

Replacing the Motor Module

- 1 - Disconnect electrical power to unit.
- 2 - Remove unit access panel.
- 3 - Unplug the two harnesses from the motor control module. See figure 15.

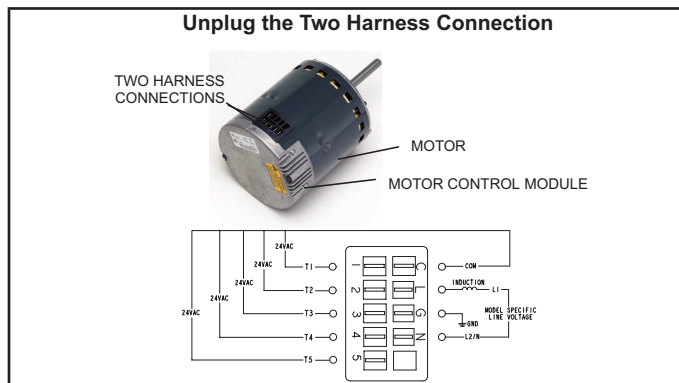

FIGURE 15

- 4 - Remove the two hex head bolts securing the motor control module to the motor (see figure 16).



FIGURE 16

- 5 - Slide the motor control module away from the motor to access and disconnect the internal three wire connector. It is not necessary to remove blower motor itself. Set both hex head bolts aside.

Testing the Motor (Figure 17)

If any motor fails the below tests, do not install the new control module. The motor is defective and it also must be replaced. The new control can fail if placed on a defective motor.

- 1 - Using an ohmmeter check the resistance from any one of the motor connector pins to the aluminum end plate of the motor. This resistance should be greater than 100k ohms.
- 2 - Check the resistances between each of the three motor connector pins. These should all read approximately the same resistance within an ohm.
- 3 - Check to see if the blower wheel spins freely.



FIGURE 17

TABLE 9

Scale	Measurement range in words	ohms
2 M	two megohm-two million ohms	0 - 2,000,000
200 K	two hundred kilo-ohm-two hundred thousand ohms	0 - 200,000
20 K	twenty kilo-ohm-twenty thousand ohms	0 - 20,000
2 K	two kilo-ohm two-thousand ohms	0 - 2,000
200	two hundred ohms	0 - 200

Motor Module Installation

All replacement motor control modules look similar; however, each module is designed for a specific motor size. It is very important to make sure that you are using the correct replacement motor control module. **USE OF THE WRONG MOTOR CONTROL MODULE MAY RESULT IN UNEXPECTED UNIT OPERATION.**

- 1 - Verify electrical power to unit is disconnected.
- 2 - Connect three-wire harness from motor to control module.
- 3 - Mount new motor control module to motor using two hex head bolts removed in figure 10. Torque bolts to 22 inch pounds or 1/16th clock wise turn.
- 4 - Reconnect the two harnesses to the motor control module.
- 5 - The electrical connectors of the motor should be facing down to form a drip loop (figure 12). This will direct moisture away from the motor and its electric connections on the motor

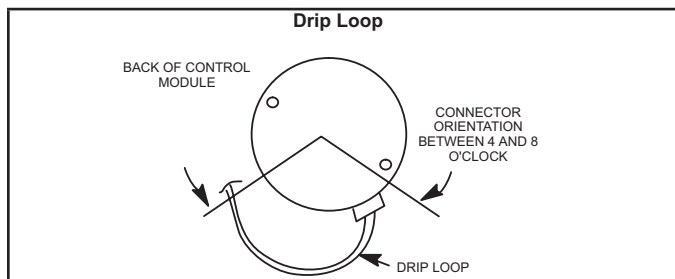

FIGURE 18

II- PLACEMENT AND INSTALLATION

Make sure unit is installed in accordance with installation instructions and applicable codes.

III- START-UP

A- Heating Start-Up

⚠ WARNING

Shock and burn hazard.
ML180UHE(X) units are equipped with a hot surface ignition system. Do not attempt to light manually.

Gas Valve Operation

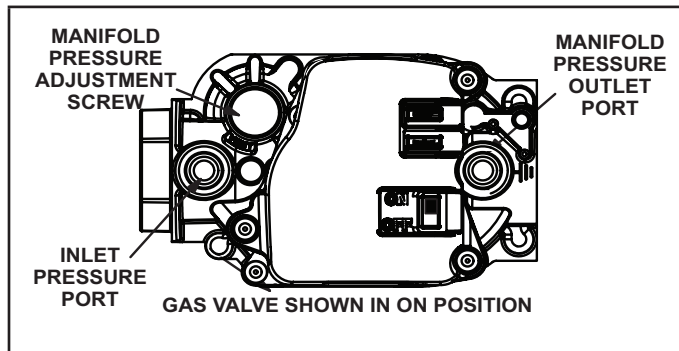

FIGURE 19

- 1 - **STOP!** Read the safety information at the beginning of this section.
- 2 - Set the thermostat to the lowest setting.
- 3 - Turn off all electrical power to the unit.
- 4 - This furnace is equipped with an ignition device which automatically lights the burners. Do not try to light the burners by hand.
- 5 - Remove the upper access panel.
- 6 - Move gas valve switch to OFF position. Do not force. See figure 19.
- 7 - Wait five minutes to clear out any gas. If you then smell gas, STOP! Immediately call your gas supplier from a neighbor's phone. Follow the gas supplier's instructions. If you do not smell gas go to next step.
- 8 - Move gas valve switch to ON position. Do not force. See figure 19.
- 9 - Replace the upper access panel.
- 10 - Turn on all electrical power to the unit.
- 11 - Set the thermostat to desired setting.

NOTE - When unit is initially started, steps 1 through 11 may need to be repeated to purge air from gas line.

- 12 - If the appliance will not operate, follow the instructions "Turning Off Gas to Unit" and call the gas supplier.

Turning Off Gas to Unit

- 1 - Set the thermostat to the lowest setting.
- 2 - Turn off all electrical power to the unit if service is to be performed.
- 3 - Remove the upper access panel.
- 4 - Move gas valve switch to OFF position. Do not force. See figure 19.
- 5 - Replace the upper access panel.

B- Safety or Emergency Shutdown

Disconnect main power to unit. Close manual and main gas valves.

C- Extended Period Shutdown

Turn off thermostat or set to "UNOCCUPIED" mode. Close all gas valves (both internal and external to unit) to guarantee no gas leaks into combustion chamber. Turn off power to unit. All access panels and covers must be in place and secured.

IV-HEATING SYSTEM SERVICE CHECKS

A- C.S.A. Certification

All units are C.S.A. design certified without modifications. Refer to the ML180UHE(X) Installation Instruction.

B- Gas Piping

Gas supply piping should not allow more than 0.5"W.C. drop in pressure between gas meter and unit. Supply gas pipe must not be smaller than unit gas connection. Compounds used on gas piping threaded joints should be resistant to action of liquefied petroleum gases.

C- Testing Gas Piping

⚠ CAUTION

If a flexible gas connector is required or allowed by the authority that has jurisdiction, black iron pipe shall be installed at the gas valve and extend outside the furnace cabinet.

⚠ IMPORTANT

In case emergency shutdown is required, turn off the main shut-off valve and disconnect the main power to unit. These controls should be properly labeled by the installer.

⚠ WARNING

Do not exceed 600 in-lbs (50 ft-lbs) torque when attaching the gas piping to the gas valve.

When pressure testing gas lines, the gas valve must be disconnected and isolated. Gas valves can be damaged if subjected to more than 0.5psig (14" W.C.). See figure 20. If the pressure is equal to or less than 0.5psig (14"W.C.), close the manual shut-off valve before pressure testing to isolate furnace from gas supply.

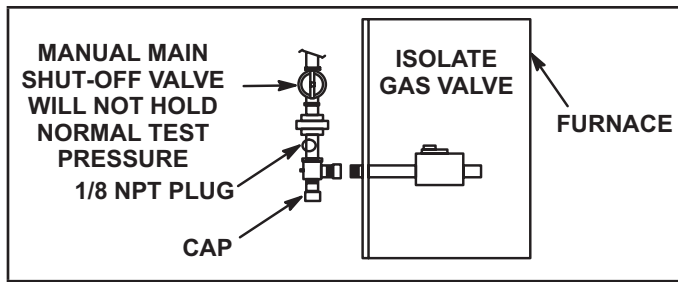

FIGURE 20

When checking piping connections for gas leaks, use preferred means. Kitchen detergents can cause harmful corrosion on various metals used in gas piping. Use of a specialty Gas Leak Detector is strongly recommended. It is available through Lennox under part number 31B2001. See Corp. 8411-L10, for further details.

Do not use matches, candles, flame or any other source of ignition to check for gas leaks.

D- Gas Pressure Adjustment

Gas Flow (Approximate)

TABLE 10

GAS METER CLOCKING CHART				
ML180UHE Unit	Seconds For One Revolution			
	Natural		LP/Propane	
	1 cu ft Dial	2 cu ft Dial	1 cu ft Dial	2 cu ft Dial
-045	80	160	200	400
-070	55	110	136	272
-090	41	82	102	204
-110	33	66	82	164
-135	27	54	68	136

Natural-1000 btu/cu ft LP-2500 btu/cu ft

Furnace should operate at least 5 minutes before checking gas flow. Determine time in seconds for two revolutions of gas through the meter. (Two revolutions assures a more accurate time.) Divide by two and compare to time in table 10. If manifold pressure matches table 12 and rate is incorrect, check gas orifices for proper size and restriction. Remove temporary gas meter if installed.

NOTE - To obtain accurate reading, shut off all other gas appliances connected to meter.

E- Supply and Manifold Pressure

Supply Pressure Measurement

- 1 - Remove the threaded plug from the inlet side of the gas valve and install a field-provided barbed fitting. Connect to a test gauge to measure supply pressure.

- 2 - Start unit and allow 5 minutes for unit to reach steady state.
- 3 - After allowing unit to stabilize for 5 minutes, record supply pressure and compare to value given in table 12.

Manifold Pressure Measurement

- 1 - Remove the threaded plug from the outlet side of the gas valve and install a field-provided barbed fitting. Connect to a test gauge to measure manifold pressure.
- 2 - Start unit and allow 5 minutes for unit to reach steady state.
- 3 - While waiting for the unit to stabilize, observe the flame. Flame should be stable and should not lift from burner. Natural gas should burn blue.
- 4 - After allowing unit to stabilize for 5 minutes, record manifold pressure and compare to value given in table 12.

NOTE - Shut unit off and remove manometer as soon as an accurate reading has been obtained. Take care to remove barbed fitting and replace threaded plug.

F- Proper Combustion

Furnace should operate a minimum 15 minutes with correct manifold pressure and gas flow rate before checking combustion. Take combustion sample beyond the flue outlet and compare to the tables below. **The maximum carbon monoxide reading should not exceed 100 ppm.**

TABLE 11

ML180UHE Unit	CO ₂ % Nat	CO ₂ % LP
-045	7.2 - 7.8	7.5 - 9.0
-070		
-090		
-110		
-135		

G- High Altitude

The manifold pressure may require adjustment and combustion air pressure switch may need replacing to ensure proper combustion at higher altitudes. Refer to table 12 for manifold pressure and table 13 for pressure switch change and gas conversion kits.

⚠ IMPORTANT

For safety, shut unit off and remove manometer as soon as an accurate reading has been obtained. Take care to replace pressure tap plug.

TABLE 12

Manifold Pressure Settings at all Altitudes

Model Input Size	Gas	0 - 2000 ft.	2001 -4500 ft .	4501 - 7500 ft.	7501 - 10,000 ft	Line Pressure in. wg.	
						Min	Max
045	Nat	3.5	3.2	3.0	3.5	4.5	13.0
	LP/Propane	10.0	10.0	10.0	10.0	11.0	13.0
070	Nat	3.5	3.2	2.8	3.5	4.5	13.0
	LP/Propane	10.0	10.0	10.0	10.0	11.0	13.0
090	Nat	3.5	3.2	2.7	3.5	4.5	13.0
	LP/Propane	10.0	10.0	9.6	10.0	11.0	13.0
110	Nat	3.5	3.5	3.0	3.5	4.5	13.0
	LP/Propane	10.0	10.0	9.6	10.0	11.0	13.0
135	Nat	3.5	3.5	2.9	3.5	4.5	13.0
	LP/Propane	10.0	10.0	9.6	10.0	11.0	13.0

TABLE 13

Pressure Switch and Gas Conversion Kits at all Altitudes

Model Input Size	High Altitude Pressure Switch Kit			High Altitude Natural Gas Orifice Kit	LP/Propane Orifice Kit		Natural Gas Orifice Kit
	0-4500 ft	4501-7500 ft	7501-10,000 ft	7501-10,000 ft	0-7500 ft	7501-10,000 ft	0-7500 ft
045							
070	No Change	80W52	80W51	73W37	11K49	11K44	73W81
110		80W52	80W51				
090		80W52	80W51				
110		80W57	80W52				
135		80W52	80W51				

NOTE - A natural to L.P. propane gas changeover kit is necessary to convert this unit. Refer to the changeover kit installation instruction for the conversion procedure.

H- Proper Ground and Voltage

A poorly grounded furnace can contribute to poor flame sense signal. Use the following procedure to check for ground and voltage to the integrated control.

- 1 - Measure the AC voltage between Line Neutral (spade terminals) and "C" terminal (low voltage terminal block) on the integrated control. See figure 21. A wide variation in the voltage between Line Neutral and "C" as a function of load indicates a poor or partial ground. Compare the readings to the table below. If the readings exceed the maximum shown in table 14, make repairs before operating the furnace.
- 2 - In addition, measure the AC voltage from Line Hot to Line Neutral (spade terminals) on the integrated control. See figure 22. This voltage should be in the range of 97 to 132 Vac.

TABLE 14

Furnace Status	Measurement VAC	
	Expected	Maximum
Power on Furnace Idle	0.3	2
CAI/Ignitor Energized	0.75	5
Indoor Blower Energized	Less than 2	10

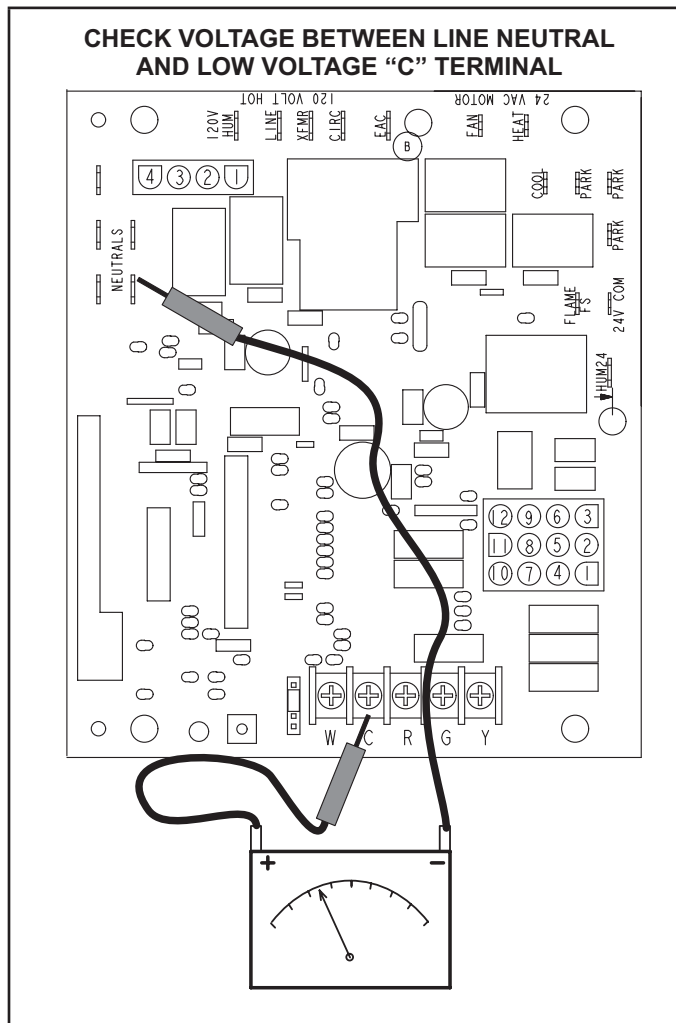

FIGURE 21

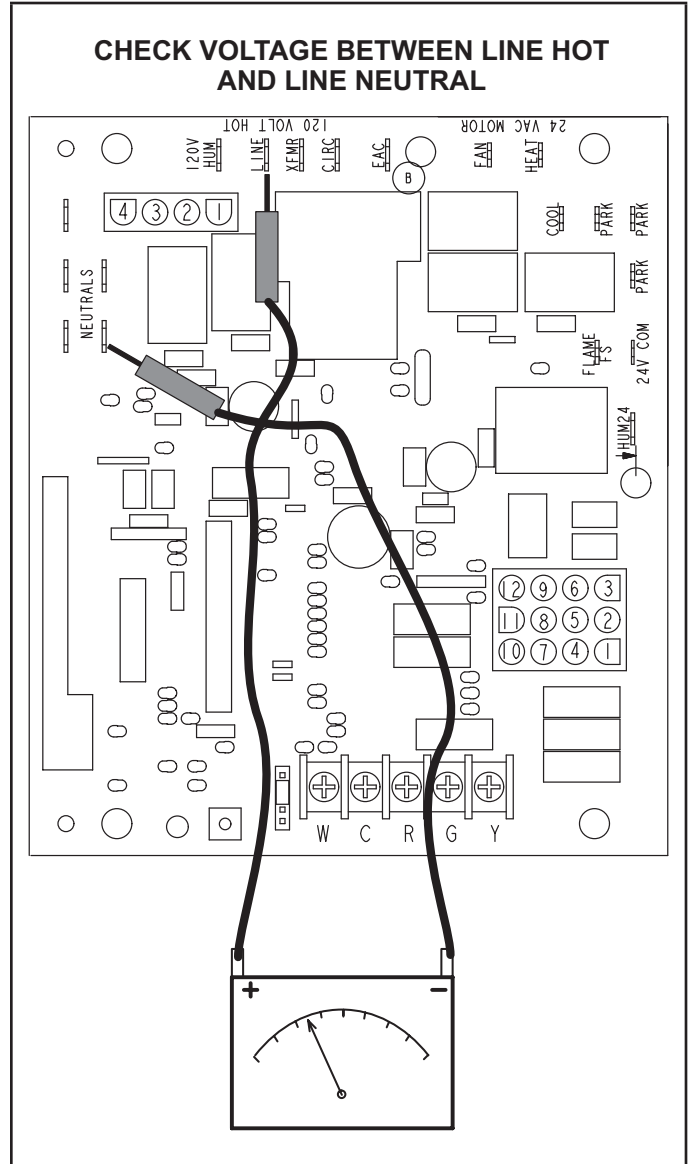

FIGURE 22

V-TYPICAL OPERATING CHARACTERISTICS

A-Blower Operation and Adjustment

NOTE- The following is a generalized procedure and does not apply to all thermostat controls.

- 1 - Blower operation is dependent on thermostat control system.
- 2 - Generally, blower operation is set at thermostat subbase fan switch. With fan switch in ON position, blower operates continuously. With fan switch in AUTO position, blower cycles with demand or runs continuously while heating or cooling circuit cycles.
- 3 - Depending on the type of indoor thermostat, blower and entire unit will be off when the system switch is in OFF position.

B-Temperature Rise (Figure 23)

Temperature rise for ML180UHE(X) units depends on unit input, blower speed, blower horsepower and static pressure as marked on the unit rating plate. The blower speed must be set for unit operation within the range of "TEMP. RISE °F" listed on the unit rating plate.

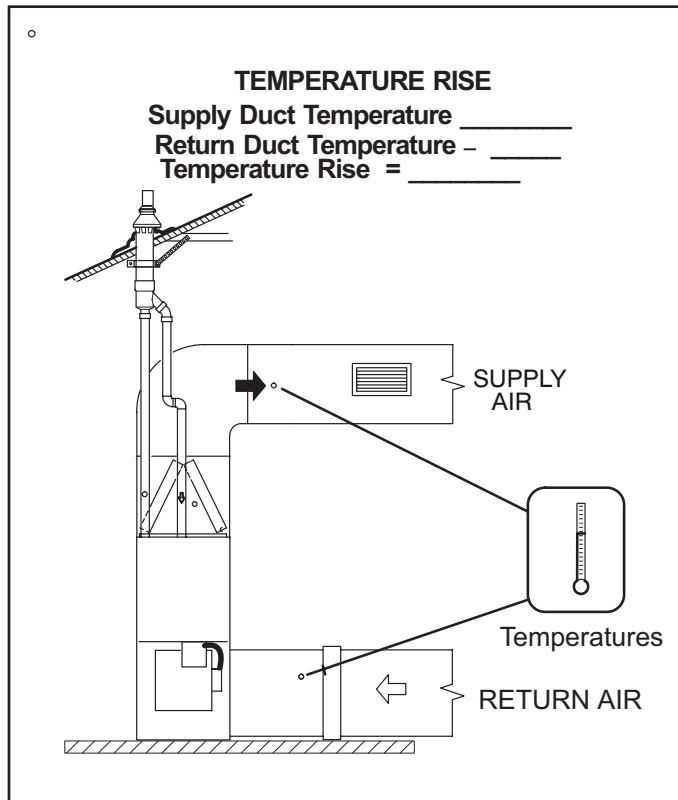

FIGURE 23

C-External Static Pressure

- 1 - Tap locations shown in figure 24 .
- 2 - Punch a 1/4" diameter hole in supply and return air plenums. Insert manometer hose flush with inside edge of hole or insulation. Seal around the hose with permagum. Connect the zero end of the manometer to the discharge (supply) side of the system. On ducted systems, connect the other end of manometer to the return duct as above.
- 3 - With only the blower motor running and the evaporator coil dry, observe the manometer reading. Adjust blower motor speed to deliver the air desired according to the job requirements. For heating speed external static pressure drop must not be more than 0.5" W.C. For cooling speed external static pressure drop must not be more than 0.8" W.C.
- 4 - Seal the hole when the check is complete.

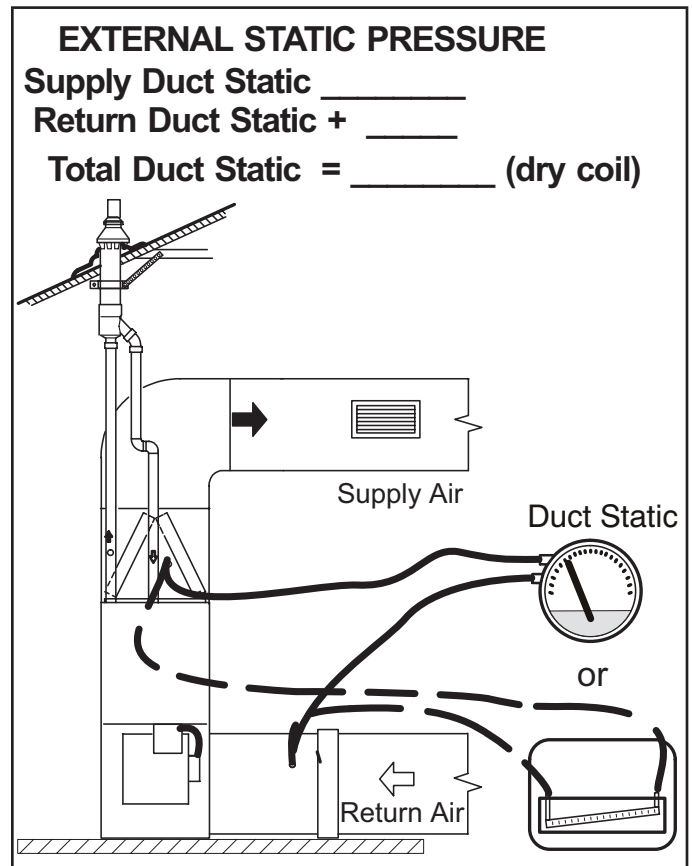

FIGURE 24

VI-MAINTENANCE

At the beginning of each heating season, and to comply with the Lennox Limited Warranty, your system should be checked by a licensed professional technician (or equivalent) as follows:

IMPORTANT

If a highefficiency filter is being installed as part of this system to ensure better indoor air quality, the filter must be properly sized. Highefficiency filters have a higher static pressure drop than standardefficiency glass/foam filters. If the pressure drop is too great, system capacity and performance may be reduced.

The pressure drop may also cause the limit to trip more frequently during the winter and the indoor coil to freeze in the summer, resulting in an increase in the number of service calls.

Before using any filter with this system, check the specifications provided by the filter manufacturer against the data given in the appropriate Lennox Product Specifications bulletin. Additional information is provided in Service and Application Note ACC002 (August 2000).

WARNING

Fire Hazard. Use of aluminum wire with this product may result in a fire, causing property damage, severe injury or death. Use copper wire only with this product.

WARNING

Failure to use properly sized wiring and circuit breaker may result in property damage. Size wiring and circuit breaker(s) per Product Specifications bulletin (EHB) and unit rating plate.

- 1 - Check wiring for loose connections, voltage at indoor unit and amperage of indoor motor.
- 2 - Check the condition of the belt and shaft bearings if applicable.
- 3 - Inspect all gas pipe and connections for leaks.
- 4 - Check the cleanliness of filters and change if necessary (monthly).

TABLE 15

Furnace Cabinet Width	Filter Size	
	Side Return	Bottom Return
A - 14-1/2"	16 X 25 X 1 (1)	14 X 25 X 1 (1)
B - 17-1/2"	16 X 25 X 1 (1)	16 X 25 X 1 (1)
C - 21"	16 X 25 X 1 (1)	20 x 25 x 1 (1)
D - 24-1/2"	16 X 25 X 1 (2)	24 x 25 x 1 (1)

- 5 - Check the condition and cleanliness of burners and heat exchanger and clean if necessary.
- 6 - Check the cleanliness of blower assembly and clean the housing, blower wheel and blower motor if necessary . The blower motors are prelubricated for extended bearing life. No further lubrication is needed.
- 7 - Inspect the combustion air inducer and clean if necessary.
- 8 - Evaluate the heat exchanger integrity by inspecting the heat exchanger per the AHRI heat exchanger inspection procedure. This procedure can be viewed at www.ahrinet.org
- 9 - Ensure sufficient combustion air is available to the furnace. Fresh air grilles and louvers (on the unit and in the room where the furnace is installed) must be properly sized, open and unobstructed to provide combustion air.
- 10 - Inspect the furnace venting system to make sure it is in place, structurally sound, and without holes, corrosion, or blockage. Vent system must be free and clear of obstructions and must slope upward away from the furnace . Vent system should be installed per the National Fuel Gas Code.
- 11 - Inspect the furnace return air duct connection to ensure the duct is sealed to the furnace. Check for air leaks on supply and return ducts and seal where necessary.
- 12 - Check the condition of the furnace cabinet insulation and repair if necessary.
- 13 - Perform a complete combustion analysis during the furnace inspection to ensure proper combustion and operation. Consult Service Literature for proper combustion values.
- 14 - Verify operation of CO detectors and replace batteries as required.

Perform a general system test. Turn on the furnace to check operating functions such as the start-up and shut-of operation.

- 1 - Check the operation of the ignition system, inspect and clean flame sensor. Check microamps before and after. Check controls and safety devices (gas valve, flame sensor, temperature limits). Consult Service Manual for proper operating range. Thermal Limits should be checked by restricting airflow and not disconnecting the indoor blower. For additional details, please see Service and Application Note H049.
- 2 - Verify that system total static pressure and airflow settings are within specific operating parameters.

- 3 - Clock gas meter to ensure that the unit is operating at the specified firing rate. Check the supply pressure and the manifold pressure. On two-stage gas furnaces check the manifold pressure on high fire and low fire. If manifold pressure adjustment is necessary, consult the Service Literature for unit specific information on adjusting gas pressure. Not all gas valves are adjustable. Verify correct temperature rise.

Cleaning the Heat Exchanger and Burners

NOTE - Use papers or protective covering in front of the furnace during cleaning.

- 1 - Turn off both electrical and gas power supplies to furnace.
- 2 - Remove flue pipe and top cap (some applications top cap can remain) from the unit.

- 3 - Label the wires from gas valve, rollout switches, primary limit switch and make-up box then disconnect them.
- 4 - Remove the screws that secure the combustion air inducer/ pressure switch assembly to the collector box. Carefully remove the combustion air inducer to avoid damaging blower gasket. If gasket is damaged, it must be replaced to prevent leakage.
- 5 - Remove the collector box located behind the combustion air inducer. Be careful with the collector box gasket. If the gasket is damaged, it must be replaced to prevent leakage.
- 6 - Disconnect gas supply piping. Remove the four screws securing the burner manifold assembly to the vestibule panel and remove the assembly from the unit.

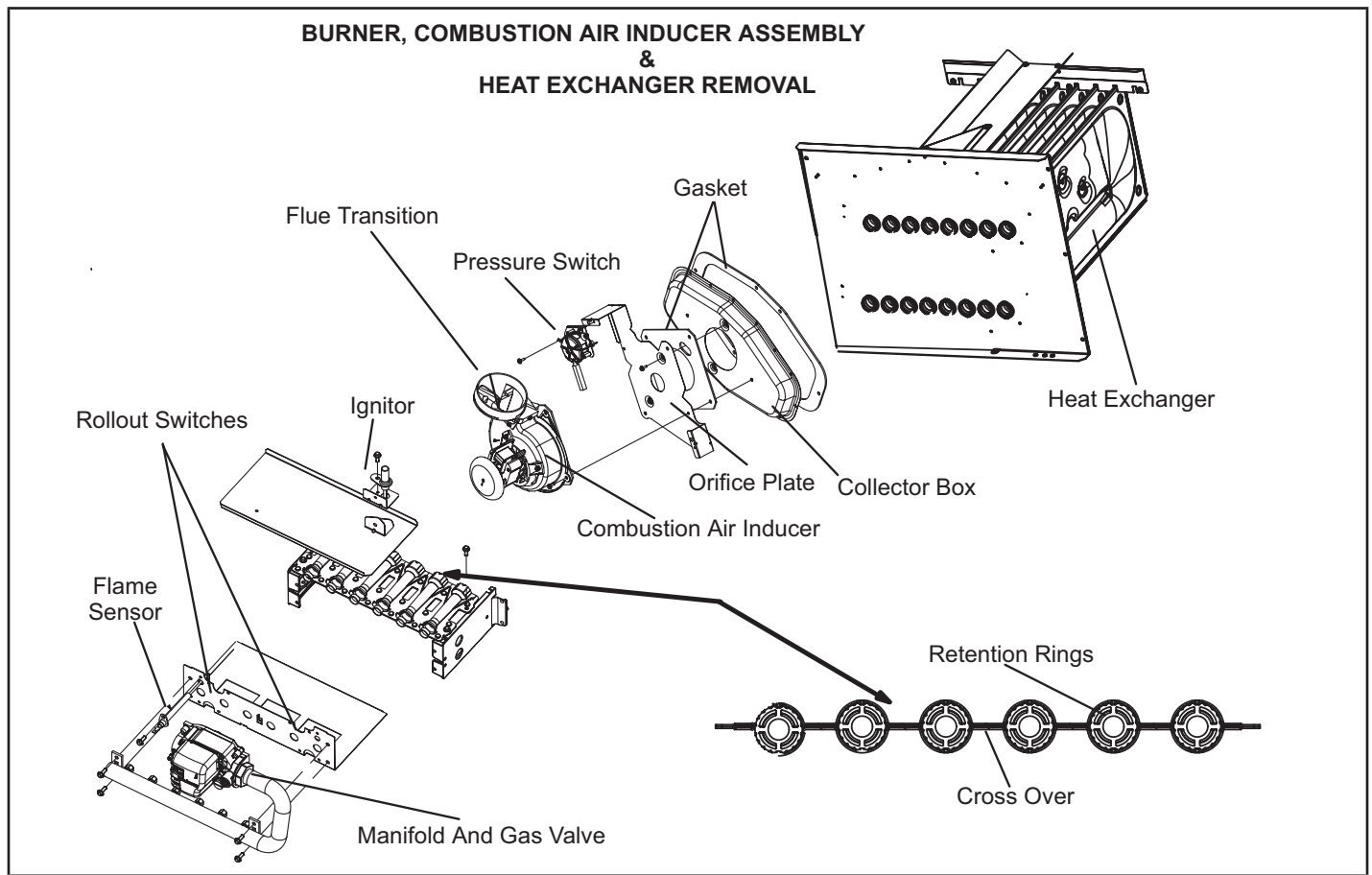

FIGURE 25

- 7 - **NOX units only** - Remove screw securing NOX insert. Remove NOX insert. See figure 26.
- 8 - Remove screws from both sides, top and bottom of vestibule panel.
- 9 - Remove heat exchanger. It may be necessary to spread cabinet side to allow more room. If so, remove five screws from the left side or right side of cabinet. See figure 27.
- 10 - Backwash using steam. Begin from the burner opening on each clam. Steam must not exceed 275°F.
- 11 - To clean burners, run a vacuum cleaner with a soft brush attachment over the face of burners. Visually inspect inside the burners and crossovers for any blockage caused by foreign matter. Remove any blockage. Figure 25 shows burner detail.
- 12 - To clean the combustion air inducer visually inspect and using a wire brush clean where necessary. Use compressed air to clean off debris and any rust.
- 13 - Reinstall heat exchanger in vestibule. (Replace the five screws in the cabinet from step 10 if removed).
- 14 - NOx units only - Replace NOx inserts.
- 15 - Reinstall collector box and combustion air assembly. Reinstall all screws to the collector box and combustion air inducer. Failure to replace all screws may cause leaks. Inspect gaskets for any damage and replace if necessary.
- 16 - Reinstall burner box and manifold assembly.
- 17 - Reconnect all wires.
- 18 - Reconnect top cap and vent pipe to combustion air inducer outlet.
- 19 - Reconnect gas supply piping.
- 20 - Turn on power and gas supply to unit.
- 21 - Set thermostat and check for proper operation.
- 22 - Check all piping connections, factory and field, for gas leaks. Use a leak detecting solution or other preferred means.
- 23 - If a leak is detected, shut gas and electricity off and repair leak.

⚠ CAUTION

Some soaps used for leak detection are corrosive to certain metals. Carefully rinse piping thoroughly after leak test has been completed. Do not use matches, candles, flame or other sources of ignition to check for gas leaks.

- 24 - Repeat steps 24 and 26 until no leaks are detected.
- 25 - Replace access panel.

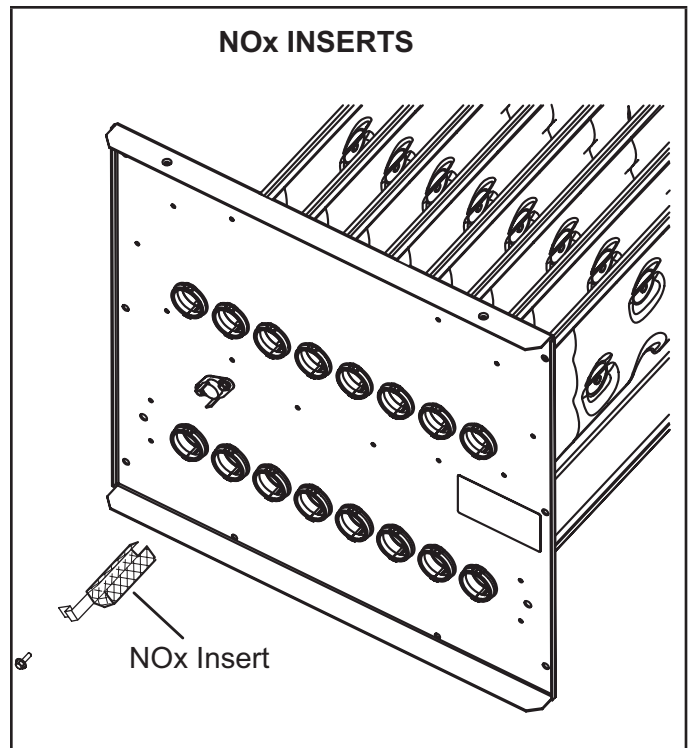

FIGURE 26

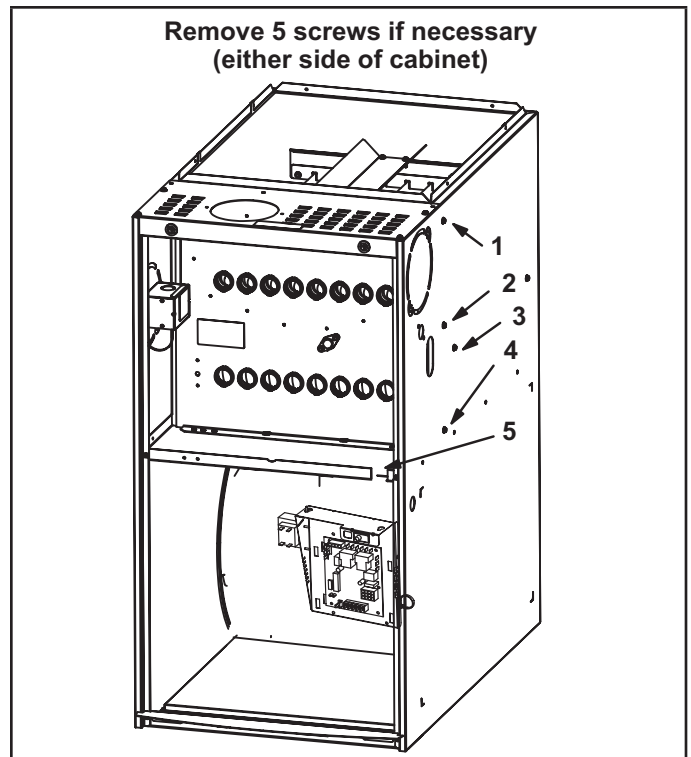
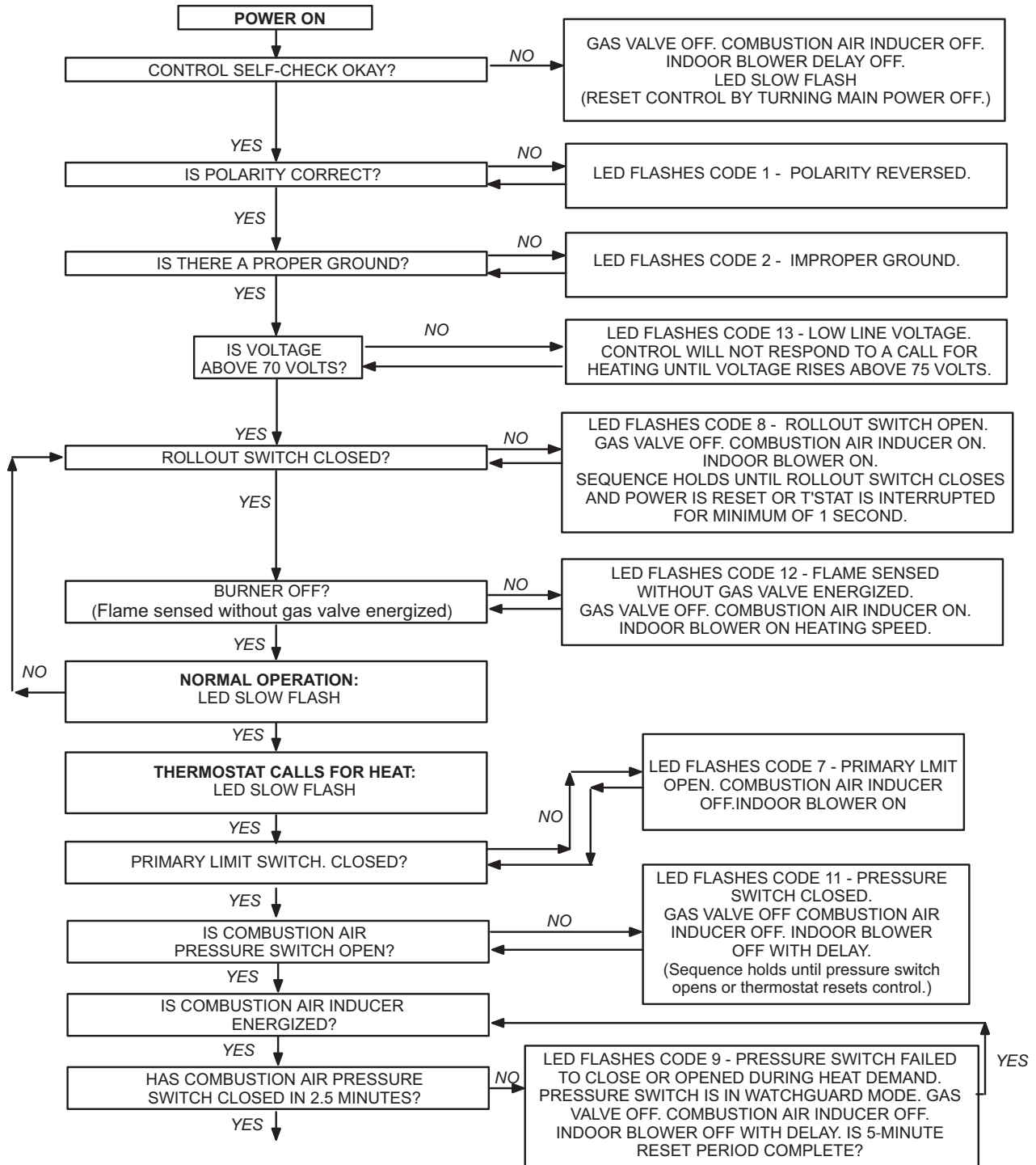

FIGURE 27

HEATING SEQUENCE OF OPERATION

NORMAL HEATING MODE

ABNORMAL HEATING MODE



CONTINUED NEXT PAGE

HEATING SEQUENCE CONTINUED

NORMAL HEATING MODE

ABNORMAL HEATING MODE

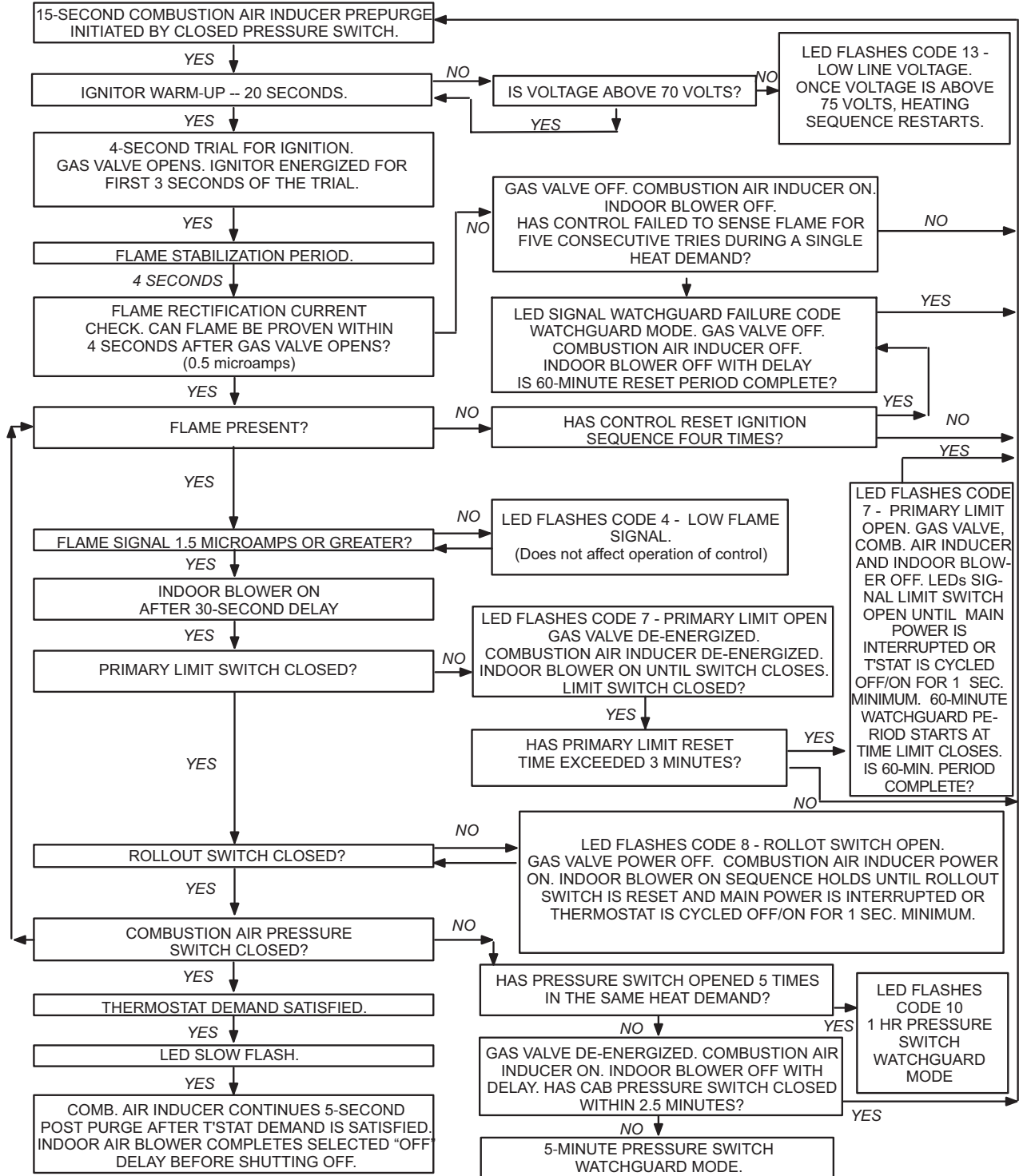

COOLING SEQUENCE OF OPERATION

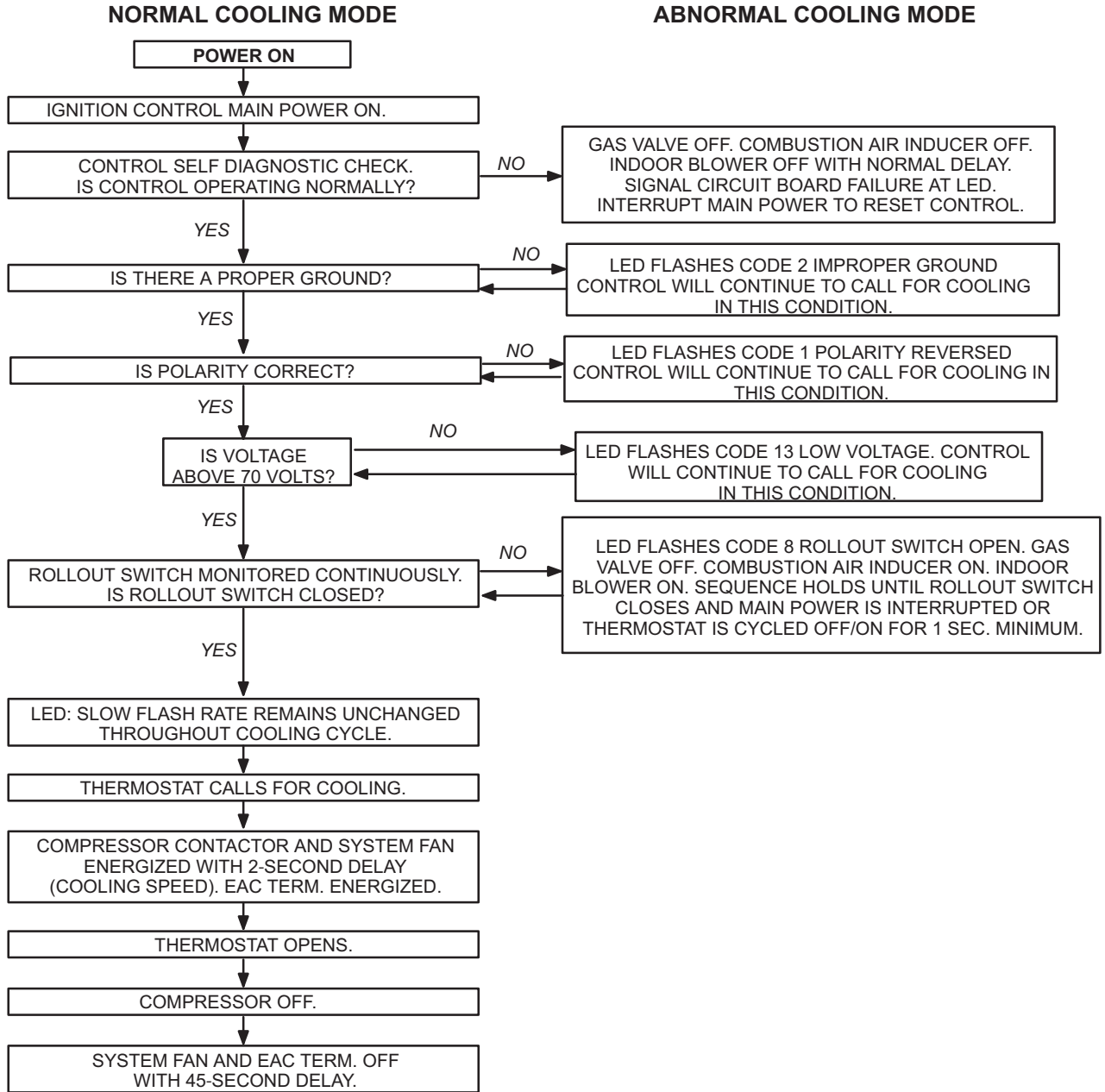

CONTINUOUS FAN SEQUENCE OF OPERATION

