

EL296DFE SERIES UNITS

EL296DFE series units are high efficiency condensing gas furnaces used for downflow applications only, manufactured with Lennox Duralok heat exchangers formed of aluminized steel. EL296DFE units are available in heating capacities of 44,000 to 110,000 Btuh and cooling applications up to 5 tons. Refer to Product Specifications Manual for proper sizing.

Units are factory equipped for use with natural gas. Kits are available for conversion to LPG operation. EL296DFE model units are equipped with the SureLight® two-stage constant torque integrated control. EL296DFE unit meets the California Nitrogen Oxides (NOx) Standards and California Seasonal Efficiency requirements. All units use a redundant gas valve to assure safety shut-off as required by C.S.A.

All specifications in this manual are subject to change. Procedures outlined in this manual are presented as a recommendation only and do not supersede or replace local or state codes. In the absence of local or state codes, the guidelines and procedures outlined in this manual (except where noted) are recommendations only and do not constitute code.

TABLE OF CONTENTS

Specifications	Page 2
Blower Performance Data	Page 4
I Unit Components	Page 6
II Installation	Page 23
III Start Up	Page 46
IV Heating System Service Checks	Page 47
V Typical Operating Characteristics	Page 50
VI Maintenance	Page 51
VII Wiring and Sequence of Operation	Page 54
VIII Field Wiring and Jumper Settings	Page 57
X Troubleshooting	Page 61



⚠ WARNING
Improper installation, adjustment, alteration, service or maintenance can cause property damage, personal injury or loss of life. Installation and service must be performed by a licensed professional HVAC installer (or equivalent), service agency or the gas supplier.

⚠ CAUTION
As with any mechanical equipment, contact with sharp sheet metal edges can result in personal injury. Take care while handling this equipment and wear gloves and protective clothing.

SPECIFICATIONS

Model No.		EL296DF045XE36B	EL296DF070XE48B	EL296DF090XE48C	EL296DF110XE60C		
Gas Heating Performance	AHRI Ref. No.	5625722	5625723	5940633	5625725		
	¹ AFUE	96%	96%	96%	96%		
	High Fire	Input - Btuh	44,000	66,000	88,000	110,000	
		Output - Btuh	43,000	64,000	85,000	106,000	
	Temperature rise range - °F		35-65	35-65	40-70	45-75	
	Gas Manifold Pressure (in. w.g.) Nat. Gas / LPG/Propane		3.5 / 10.0	3.5 / 10.0	3.5 / 10.0	3.5 / 10.0	
	Low Fire	Input - Btuh	29,000	43,000	57,000	72,000	
		Output - Btuh	28,000	42,000	55,000	70,000	
		Temperature rise range - °F		20 - 50	25 - 55	30 - 60	35 - 65
		Gas Manifold Pressure (in. w.g.) Nat. Gas / LPG/Propane		1.7 / 4.5	1.7 / 4.5	1.7 / 4.5	1.7 / 4.5
High static - in. w.g.		0.5	0.5	0.5	0.5		
Connections in.	Intake / Exhaust Pipe (PVC)	2 / 2	2 / 2	2 / 2	2 / 2		
	Gas pipe size IPS	1/2	1/2	1/2	1/2		
	Condensate Drain Trap (PVC pipe) - i.d.	3/4	3/4	3/4	3/4		
	with furnished 90° street elbow with field supplied (PVC coupling) - o.d.	3/4 slip x 3/4 Mipt 3/4 slip x 3/4 MPT	3/4 slip x 3/4 Mipt 3/4 slip x 3/4 MPT	3/4 slip x 3/4 Mipt 3/4 slip x 3/4 MPT	3/4 slip x 3/4 Mipt 3/4 slip x 3/4 MPT		
Indoor Blower	Wheel nom. diameter x width - in.	10 x 8	11-1/2 x 10	10 x 10	11 x 11		
	Motor Type	DC Brushless	DC Brushless	DC Brushless	DC Brushless		
	Motor output - hp	1/2	3/4	3/4	1		
	Tons of add-on cooling	1.5 - 3	2 - 4	2 - 4	3 - 5		
	Air Volume Range - cfm	485 - 1395	520 - 1770	760 - 1765	1045 - 2285		
Electrical Data	Voltage	120 volts - 60 hertz - 1 phase					
	Blower motor full load amps	6.8	8.4	8.4	10.9		
	Maximum overcurrent protection	15	15	15	15		
Shipping Data	lbs. - 1 package	134	145	163	175		

NOTE - Filters and provisions for mounting are not furnished and must be field provided.

¹ Annual Fuel Utilization Efficiency based on DOE test procedures and according to FTC labeling regulations. Isolated combustion system rating for non-weatherized furnaces.

OPTIONAL ACCESSORIES - ORDER SEPARATELY

		"B" Width Models	"C" Width Models	
CABINET ACCESSORIES				
Downflow Combustible Flooring Base		11M60	11M61	
High Performance Economizer (Commercial Only)		10U53	10U53	
CONTROLS				
Blower Relay Kit (for two-stage outdoor units)		85W66	85W66	
Furnace Twinning Kit		16W72	16W72	
iComfort® E30 Smart Wi-Fi Thermostat		20A65	20A65	
Remote Outdoor Temperature Sensor		X2658	X2658	
Night Service Kit		10B39	10B39	
CONDENSATE DRAIN KITS				
Condensate Drain Heat Cable	6 ft.	26K68	26K68	
	24 ft.	26K69	26K69	
Crawl Space Vent Drain Kit	US	51W18	51W18	
	Canada	15Z70	15Z70	
FILTERS				
¹ Downflow Filter Cabinet		51W07	51W08	
	No. and Size of filter - in.	(2) 16 x 20 x 1	(2) 16 x 20 x 1	
TERMINATION KITS				
See Installation Instructions for specific venting information.				
Direct Vent	Concentric	US - 2 in.	71M80	69M29
		3 in.	---	60L46
		Canada - 2 in.	44W92	44W92
		3 in.	---	44W93
	Flush-Mount	US - 2, 2-1/2 or 3 in.	51W11	51W11
		Canada - 2, 2-1/2 or 3 in.	51W12	51W12
Wall - Close Couple		US - 2 in.	22G44	---
		3 in.	44J40	44J40
Wall - Close Couple WTK		Canada - 2 in.	30G28	---
		3 in.	81J20	81J20
Roof Termination Flashing Kit (no vent pipe - 2 flashings)		2 in.	15F75	15F75
		3 in.	44J41	44J41
VENTING				
Flue Coupling		2 in.	17H92	17H92
² Left Side Vent Kit		2 or 3 in.	87W73	87W73

¹ Cleanable polyurethane, frame-type filter.

² NOTE - The curved exhaust pipe furnished with the Left Side Vent Kit counts as one additional 2 in. diameter 90° elbow. When using 3 in. diameter pipe, the furnished curved exhaust pipe and field provided fittings to transition from 2 in. to 3 in. count as 20 feet of equivalent pipe on all units.

NOTE - Termination Kits (44W92, 44W93, 30G28, 51W12, 81J20) and Crawl Space Vent Drain Kit (15Z70) are certified to ULC S636 standard for use in Canada only.

BLOWER DATA**EL296DF045XE36B PERFORMANCE (Less Filter)**

External Static Pressure in. w.g.	Air Volume / Watts at Various Blower Speeds									
	High (Black)		Medium-High (Brown)		Medium (Blue)		Medium-Low (Yellow)		Low (Red)	
	cfm	Watts	cfm	Watts	cfm	Watts	cfm	Watts	cfm	Watts
0.00	1395	335	1290	250	1190	195	910	105	865	95
0.10	1375	350	1245	260	1140	205	875	110	815	100
0.20	1320	360	1215	265	1090	215	825	120	785	110
0.30	1285	365	1165	270	1065	225	795	130	735	115
0.40	1275	375	1150	285	1025	230	750	135	705	120
0.50	1230	385	1095	295	985	240	705	145	650	125
0.60	1185	380	1060	300	935	245	655	150	605	135
0.70	N/A	N/A	1020	310	915	250	590	150	545	140
0.80	N/A	N/A	980	315	860	255	555	160	485	140

EL296DF070XE48B PERFORMANCE (Less Filter)

External Static Pressure in. w.g.	Air Volume / Watts at Various Blower Speeds									
	High (Black)		Medium-High (Brown)		Medium (Blue)		Medium-Low (Yellow)		Low (Red)	
	cfm	Watts	cfm	Watts	cfm	Watts	cfm	Watts	cfm	Watts
0.00	1770	510	1550	340	1355	220	1255	180	1035	115
0.10	1720	520	1510	355	1315	230	1200	185	980	105
0.20	1705	535	1470	365	1265	245	1165	195	895	110
0.30	1665	540	1430	380	1235	250	1120	205	835	120
0.40	1605	555	1390	395	1185	260	1070	210	775	130
0.50	1585	565	1335	400	1155	275	1015	225	690	140
0.60	1540	565	1300	410	1100	290	970	235	625	145
0.70	N/A	N/A	1260	420	1050	295	915	245	570	150
0.80	N/A	N/A	1220	430	1015	305	865	255	520	155

EL296DF090XE48C PERFORMANCE (Less Filter)

External Static Pressure in. w.g.	Air Volume / Watts at Various Blower Speeds									
	High (Black)		Medium-High (Brown)		Medium (Blue)		Medium-Low (Yellow)		Low (Red)	
	cfm	Watts	cfm	Watts	cfm	Watts	cfm	Watts	cfm	Watts
0.00	1765	395	1565	265	1410	210	1290	175	1180	135
0.10	1745	410	1510	280	1365	220	1265	185	1120	140
0.20	1685	425	1455	295	1310	235	1220	200	1080	150
0.30	1630	440	1415	310	1285	250	1165	210	1035	160
0.40	1620	450	1370	320	1245	255	1125	220	985	175
0.50	1570	465	1335	330	1185	265	1080	230	925	180
0.60	1540	470	1295	345	1145	280	1045	240	875	190
0.70	N/A	N/A	1260	355	1110	295	990	255	825	200
0.80	N/A	N/A	1210	370	1060	305	940	260	760	205

EL296DF110XE60C PERFORMANCE (Less Filter)

External Static Pressure in. w.g.	Air Volume / Watts at Various Blower Speeds									
	High (Black)		Medium-High (Brown)		Medium (Blue)		Medium-Low (Yellow)		Low (Red)	
	cfm	Watts	cfm	Watts	cfm	Watts	cfm	Watts	cfm	Watts
0.00	2285	640	1990	435	1805	330	1685	265	1480	195
0.10	2250	660	1965	450	1775	345	1630	280	1430	205
0.20	2185	675	1910	465	1720	360	1575	295	1360	215
0.30	2150	690	1850	485	1670	375	1525	310	1290	235
0.40	2085	710	1810	495	1605	395	1465	325	1255	245
0.50	2060	725	1765	515	1565	400	1420	335	1190	255
0.60	2005	745	1700	535	1510	420	1370	355	1160	270
0.70	1970	760	1665	550	1460	440	1325	370	1100	280
0.80	1910	775	1620	560	1420	450	1275	380	1045	295

PARTS IDENTIFICATION

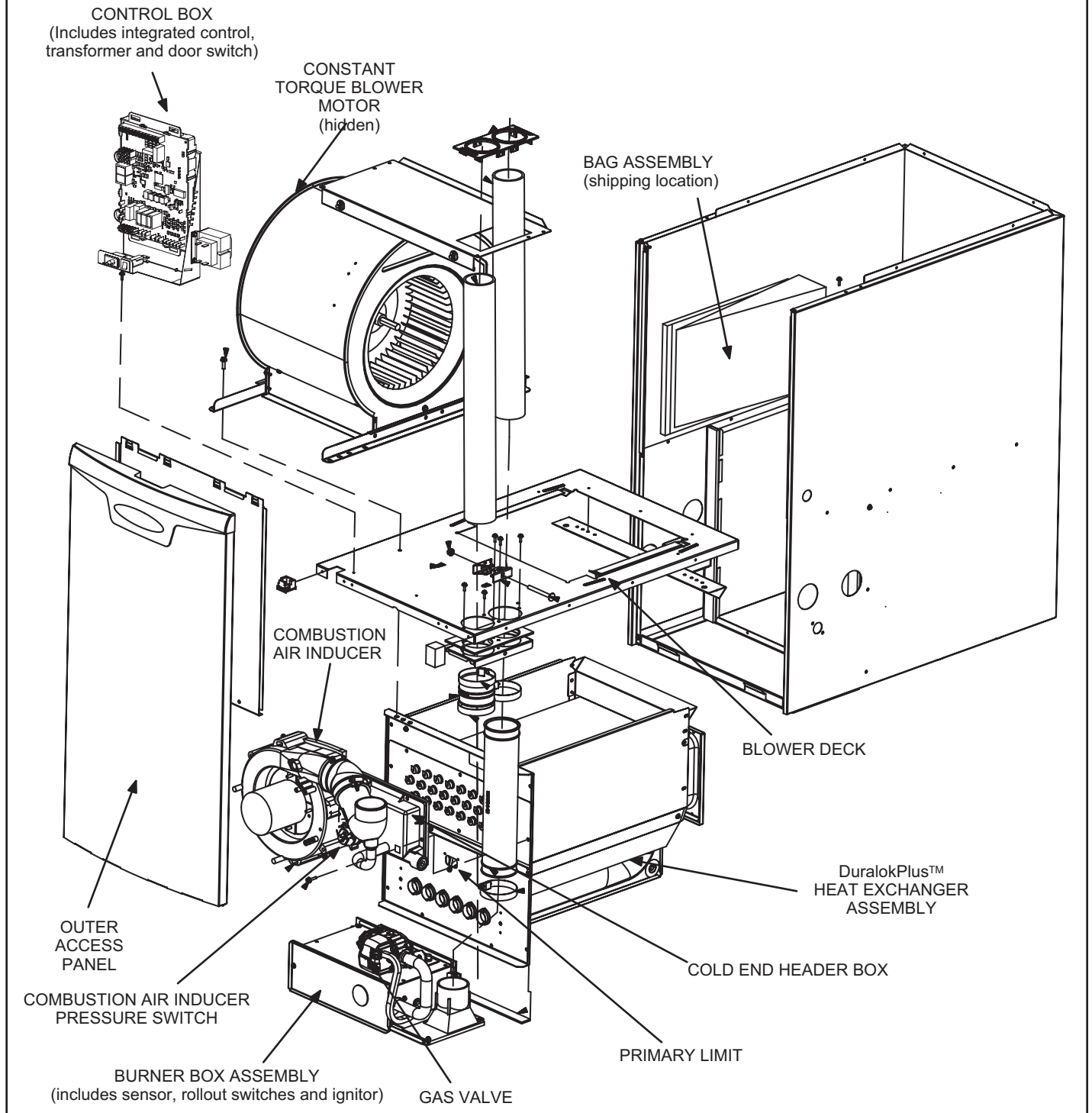

FIGURE 1

I-UNIT COMPONENTS

EL296DFE unit components are shown in FIGURE 1. The gas valve, combustion air inducer and burners can be accessed by removing the access panel. Electrical components are in the control box (FIGURE 2) found in the blower section.

ELECTROSTATIC DISCHARGE (ESD) Precautions and Procedures



A- Control Box

1. Control Transformer (T1)

A transformer located in the control box provides power to the low voltage section of the unit. Transformers on all models are rated 40VA with a 120V primary and a 24V secondary.

2. Door Interlock Switch (S51)

A door interlock switch is wired in series with line voltage. When the inner blower access panel is removed the unit will shut down.

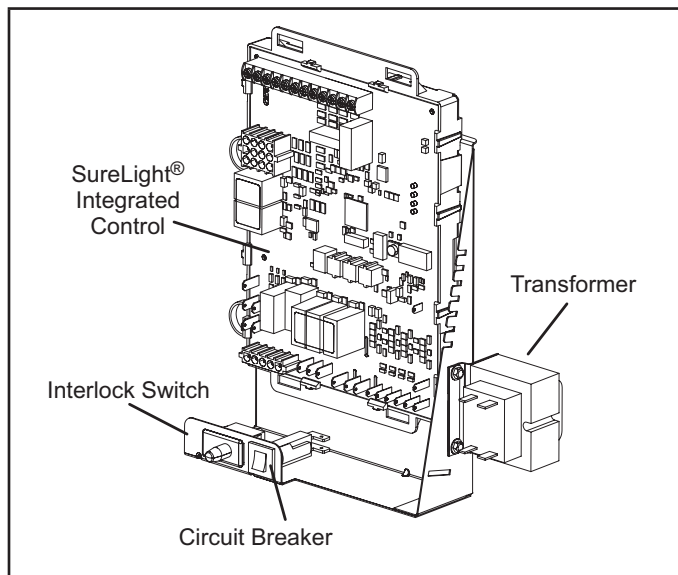

FIGURE 2

3. Circuit Breaker (CB8)

A 24V circuit breaker is also located in the control box. The switch provides overcurrent protection to the transformer (T1). The breaker can be manually reset by pressing the button on the face. See FIGURE 3.

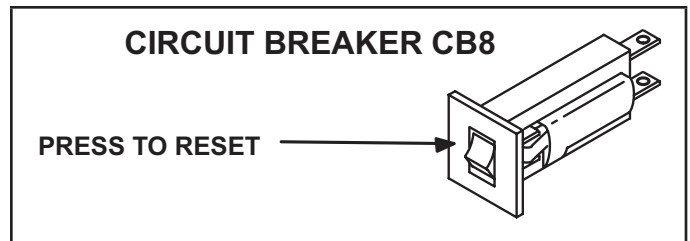

FIGURE 3

WARNING

Shock hazard.

Disconnect power before servicing. Integrated control is not field repairable. If control is inoperable, simply replace entire control.

Can cause injury or death. Unsafe operation will result if repair is attempted.

4. Integrated Control (A92)

Units are equipped with the SureLight® two-stage, integrated control. The system consists of a ignition / blower control (FIGURE 4 and FIGURE 5) with control pin designations in TABLE 1, TABLE 2 and ignitor (FIGURE 14). The control and ignitor work in combination to ensure furnace ignition and ignitor durability. The control provides gas ignition, safety checks and indoor blower control with two-stage gas heating.

The furnace combustion air inducer, gas valve and indoor blower are controlled in response to various system inputs such as thermostat signal, pressure and limit switch signal and flame signal. The control features a seven-segment LED display, indicating furnace status and error codes. The LED flashes in single digits. For example using TABLE 4 under LIMIT CODE, an "E" followed by "2" followed by "5" followed by "0", the limit switch circuit is open. The control also has two unpowered (dry) 1/4" contacts for a humidifier and a 120 volt accessory terminal. Both rated at (1) one amp each.

Electronic Ignition

At the beginning of the heat cycle the integrated control monitors the first stage and second stage combustion air inducer pressure switch. The control will not begin the heating cycle if the first stage pressure switch is closed (bypassed). Likewise the integrated control will not begin the second stage heating cycle if the second stage pressure switch is closed, and will remain in first stage heat. However, if the second stage pressure switch closes during the first stage heat pre-purge, the control will allow second stage heat. Once the first stage pressure switch is determined to be open, the combustion air inducer is energized on low (first stage) heat speed. When the differential in the pressure switch is great enough, the pressure switch closes and a 15-second pre-purge begins

After the 15-second pre-purge period, the SureLight ignitor warms up for 20 seconds after which the gas valve opens for a 4-second trial for ignition. The ignitor remains energized during the trial until flame is sensed. If ignition is not proved during the 4-second period, the control will try four more times with an inter purge and warm-up time between trials of 35 seconds. After a total of five trials for ignition (including the initial trial), the control goes into Watchguard- Flame Failure mode. After a 60-minute reset period, the control will begin the ignition sequence again.

NOTE - During abnormal conditions such as low supply voltage or low outdoor temperatures and the low fire pressure switch does not close, the combustion air inducer will switch to high speed. After the low & high pressure switch close, the unit will proceed with a 15 sec pre-purge, followed by a 20 sec ignitor warm up, then ignition on high-fire. After 10 to 20 seconds of high fire operation the unit will switch to low fire.

Two Stage Operation / Thermostat Selection DIP Switch

The control can be utilized in two modes: SINGLE-STAGE thermostat or TWO-STAGE thermostat. The thermostat selection is made using a DIP switch and must be positioned for the particular application. DIP switch 1, labeled T^hSTAT HEAT STAGE is factory-set in the OFF position for use with a two-stage thermostat. Move the DIP switch to ON for use with a single stage thermostat.

While in the single-stage thermostat mode, the burners will always fire on first-stage heat. The combustion air inducer will operate on low speed and indoor blower will operate on low heat speed. The unit will switch to second stage heat after a "recognition period". DIP switch 2, labeled SECOND STAGE DELAY, is factory set in the OFF position for a 7 minute recognition period. The switch can be moved to the ON position for a 12 minute recognition period, after which time the unit will switch to second-stage heat. While in the two-stage thermostat mode, the burners will fire on firststage heat. The combustion air inducer will operate on low speed and indoor blower will operate on low heat speed.

The unit will switch to second-stage heat on call from the indoor thermostat. If there is a simultaneous call for first and second stage heat, the unit will fire on first stage heat and switch to second stage heat after 30 seconds of operation. See Sequence of Operation flow charts in the back of this manual for more detail.

TABLE 1

SureLight® Control 5 Pin Terminal Designation	
Pin #	Function
1	Ignitor
2	Combustion Air Inducer High Speed
3	Combustion Air Inducer Low Speed
4	Combustion Air Inducer Neutral
5	Ignitor Neutral

TABLE 2

SureLight® Control 12 Pin Terminal Designation	
Pin #	Function
1	Gas Valve Second Stage
2	Pressure Switch Second Stage
3	Rolout Switch
4	Ground
5	24V Hot
6	Primary Limit In
7	Gas Valve First Stage
8	Gas Valve Common
9	24V Neutral
10	Ground
11	Primary Limit Out
12	Pressure Switch First Stage

INTEGRATED CONTROL

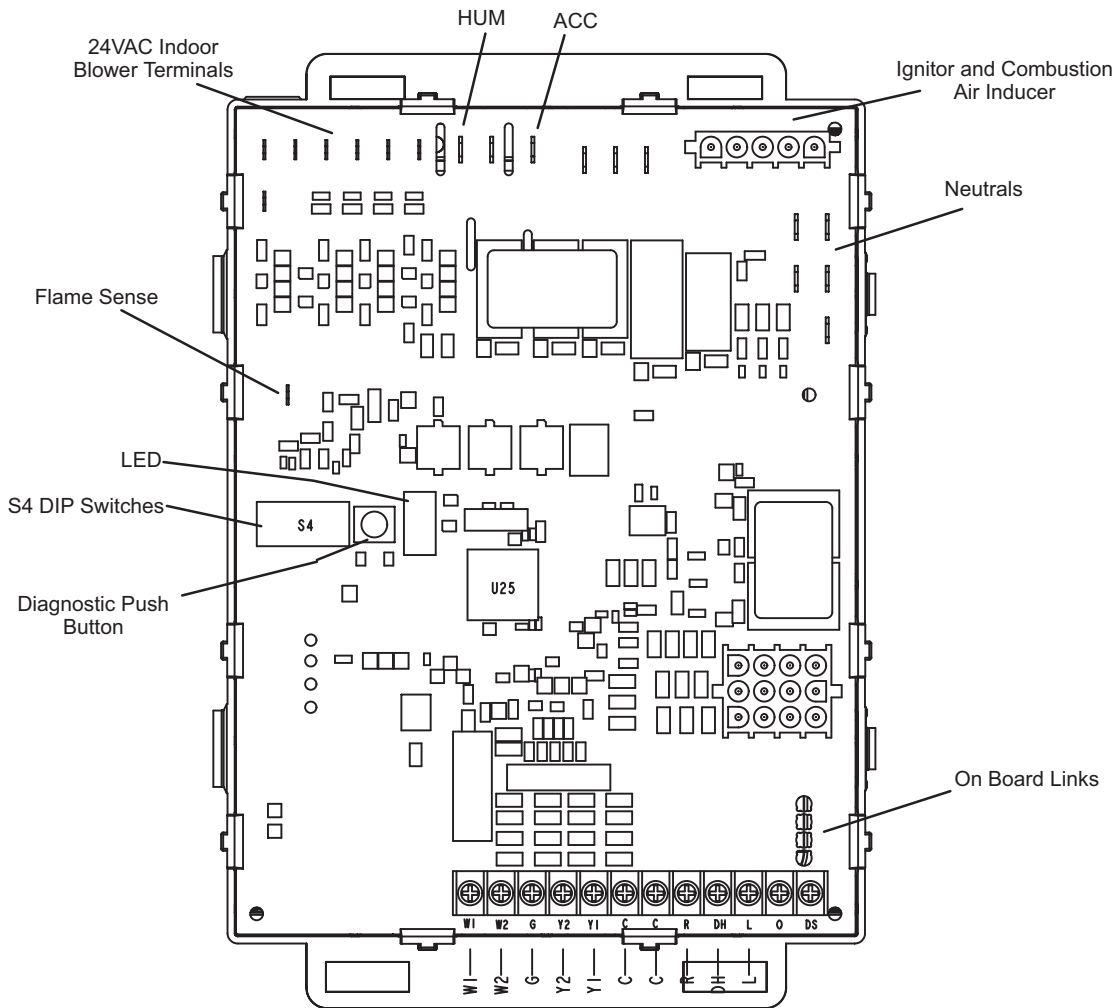

3/16" QUICK CONNECT TERMINALS

- FLAME SENSE SIGNAL
- HI COOL 24VAC
- HI HEAT 24VAC
- LO COOL 24VAC
- LO HEAT 24VAC
- PARK
- PARK
- COMMON 24VAC

1/4" QUICK CONNECT TERMINALS

- NEUTRALS = 120 VAC NEUTRAL
- HUM = UNPOWERED NORMALLY OPEN (DRY) CONTACTS
- LI = 120 VAC INPUT TO CONTROL
- ACC = 120 VAC OUTPUT TO OPTIONAL ACCESSORY

THERMOSTAT CONNECTIONS (TB1)

- DS = DEHUMIDIFICATION SIGNAL
- W2 = HEAT DEMAND FROM 2ND STAGE T/STAT
- W1 = HEAT DEMAND FROM 1ST STAGE T/STAT
- R = CLASS 2 VOLTAGE TO THERMOSTAT
- G = MANUAL FAN FROM T'STAT
- C = THERMOSTAT SIGNAL GROUND CONNECTED TO TRANSFORMER GRD (TR) & CHASIS GROUND (GRD)
- Y1 = THERMOSTAT 1ST STAGE COOL SIGNAL
- Y2 = THERMOSTAT 2ND STAGE COOL SIGNAL
- O = THERMOSTAT SIGNAL TO HEAT PUMP REVERSING VALVE
- DH = NOT USED
- L = NOT USED

FIGURE 4

UTEC TWO-STAGE CONSTANT TORQUE INTEGRATED FURNACE CONTROL

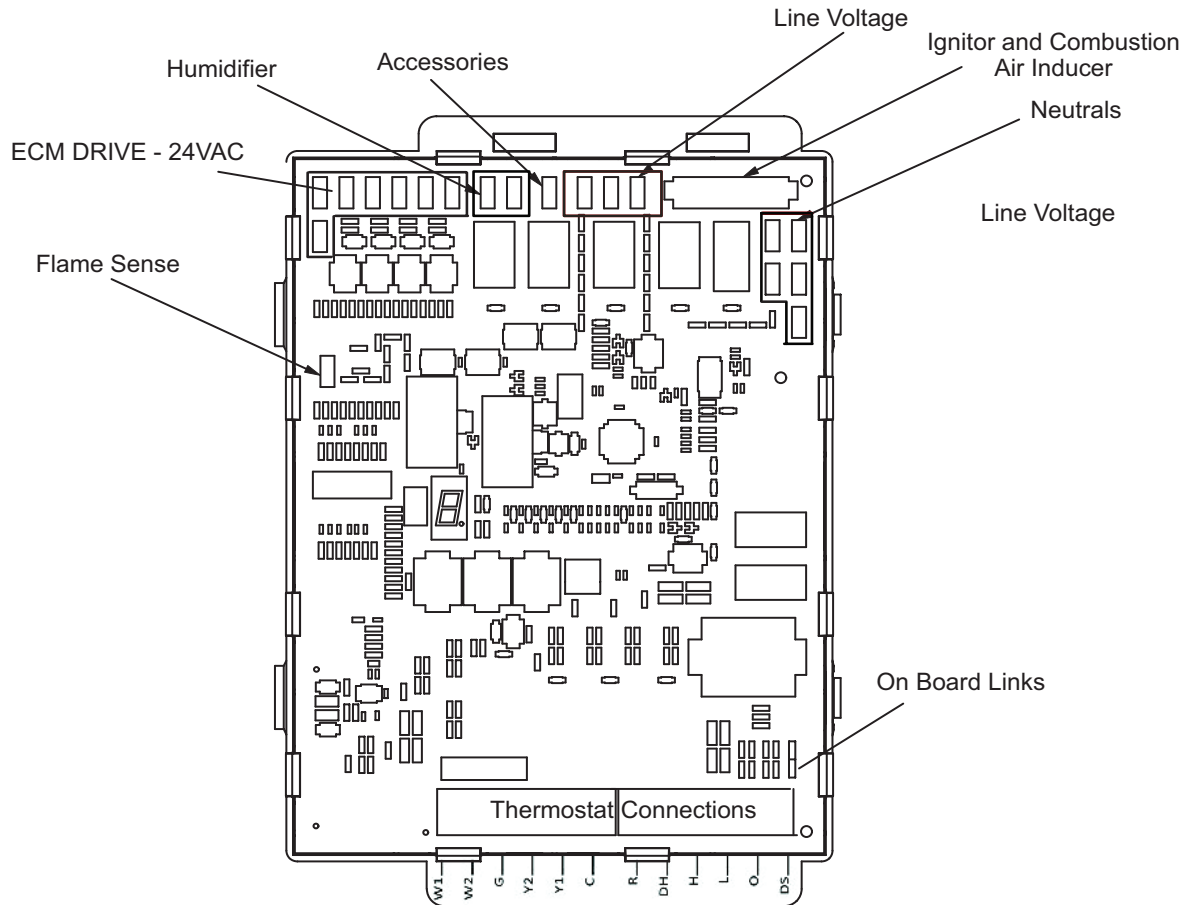

3/16" QUICK CONNECT TERMINALS

- HI COOL (24VAC)
- LO COOL (24VAC)
- HI HEAT (24VAC)
- LO HEAT (24VAC)
- PARK (two un-powered terminals for unused motor speed taps)
- FLAME SENSE

1/4" QUICK CONNECT TERMINALS

- HUM (two un-powered, normally open/dry contacts)
- ACC (120VAC output terminal for optional accessory)

THERMOSTAT CONNECTIONS

- DS= Dehumidification signal
- W2= Heat demand from 2nd stage Tstat
- W1= Heat demand from 1st stage Tstat (white)
- R= Class 2 voltage to thermostat
- G= Manual fan from Tstat (green)
- C= Tstat signal ground connected to transformer Ground (TR) & Chasis ground (GRD)
- Y1= Tstat 1st stage cool signal
- Y2= Tstat 2nd stage cool signal
- DH= NOT USED

FIGURE 5

INTEGRATED CONTROL CONFIGURATION GUIDE

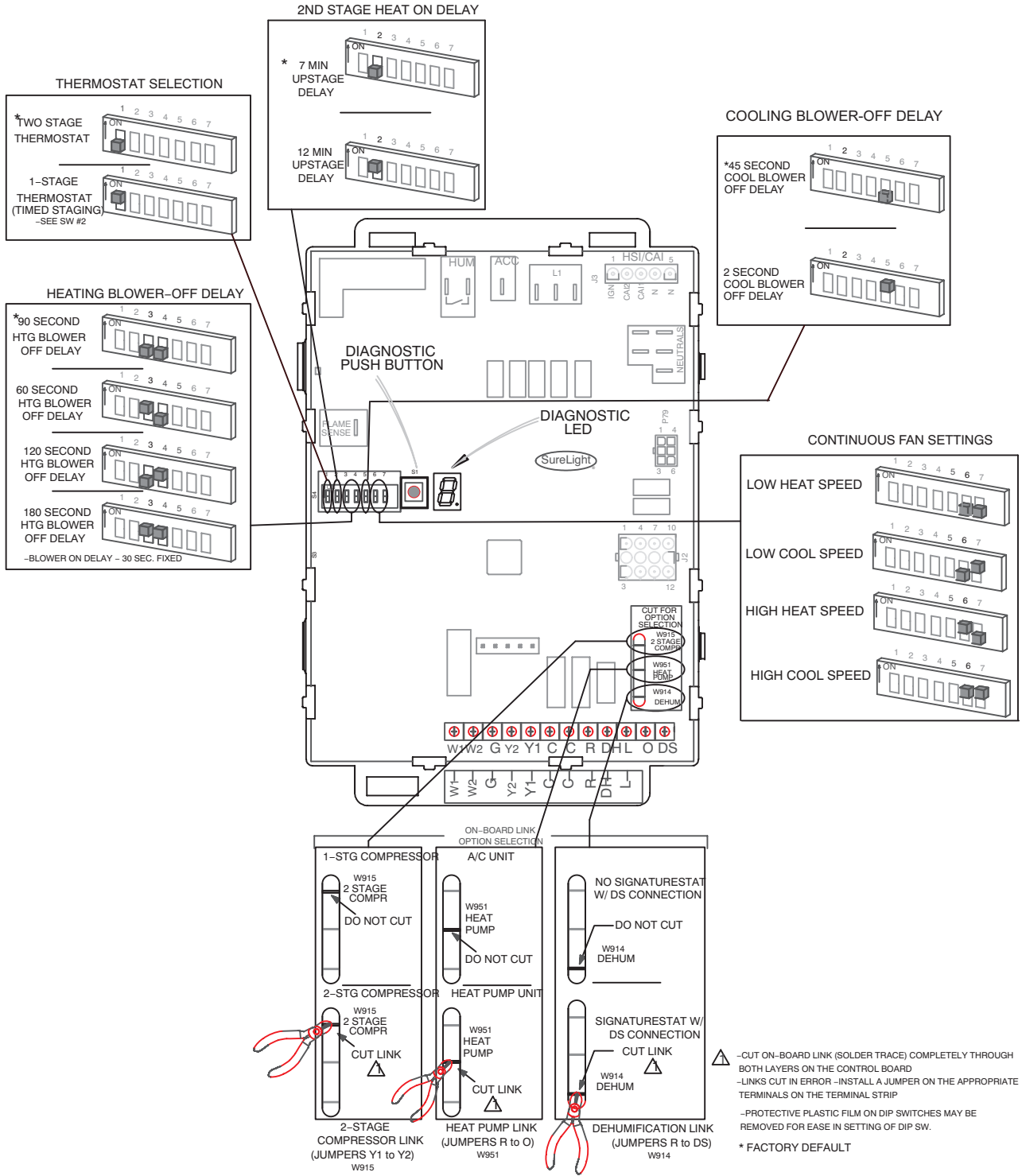

FIGURE 6

TABLE 3
Integrated Control Diagnostic Modes

Display	Action (when button released)
No Change	Remain in idle mode
Solid "E"	Enter diagnostic recall mode
Solid "F"	Enter flame signal mode

TABLE 4
Integrated Diagnostic Codes/Status of Equipment

Code	Diagnostic Codes/Status of Equipment	Action Required to Clear and Recover
.	Idle mode (Decimal blinks at 1 Hertz -- 0.5 second ON, 0.5 second OFF).	
C	Cooling stage (1 second ON, 0.5 second OFF) 1 or 2 displayed / Pause / Repeat codes.	
d	Dehumidification mode (1 second ON, 1 second OFF) / Pause / Repeat Codes).	
H	Gas Heat Stage (1 second ON, 0.5 second OFF) 1 or 2 displayed / Pause / Repeat codes. Blinking during ignition.	
h	Heat pump stage.	

Diagnostic LED

The seven-segment diagnostic LED displays operating status, error codes and other information. Table 4 lists diagnostic LED codes.

Diagnostic Push Button

The diagnostic push button is located adjacent to the seven-segment diagnostic LED. This button is used to enable the Error Code Recall "E" mode and the Flame Signal "F" mode. Press the button and hold it to cycle through a menu of options. Every five seconds a new menu item will be displayed. When the button is released, the displayed item will be selected. Once all items in the menu have been displayed, the menu resumes from the beginning until the button is released.

Error Code Recall Mode

Select "E" from the menu to access the most recent 10 error codes. Select "c" from the Error Code Recall menu to clear all error codes. Button must be pressed a second time while "c" is flashing to confirm command to delete codes.

Press the button until a solid "≡" is displayed to exit the Error Code Recall mode.

Flame Signal Mode

Select "F" from the menu to access the flame signal mode. The integrated control will display the flame current on seven-segment LED in in micro amps (uA). Flame signal mode is exited after any of the following:

- Power is reset
- Pressing and holding push button until 3 horizontal lines "≡" are displayed
- 10 minutes after entering the flame sense mode.
-

TABLE 4 Continued

E110	Low line voltage.	Line Voltage Low (Voltage lower than nameplate rating). Check power line voltage and correct. Alarm clears 5 seconds after fault recovered.
E111	Line voltage polarity reversed.	Reverse line power voltage wiring. System resumes normal operation 5 seconds after fault recovered.
E112	Ground not detected.	System shuts down. Provide proper earth ground. System resumes normal operation 5 seconds after fault recovered.
E113	High line voltage.	Line Voltage High (Voltage higher than nameplate rating). Provide power voltage within proper range. System resumes normal operation 5 seconds after fault recovered.
E114	Line voltage frequency out-of-range.	No 60 Hertz Power. Check voltage and line power frequency. Correct voltage and frequency problems. System resumes normal operation 5 seconds after fault recovered.
E115	Low 24V - Control will restart if the error recovers.	24-Volt Power Low (Range is 18 to 30 volts). Check and correct voltage. Check for additional power-robbing equipment connected to system. May require installation of larger VA transformer to be installed in furnace / air handler. Clears after fault recovered.
E117	Poor ground detected (Warning only).	Provide proper grounding for unit. Check for proper earth ground to the system. Warning only will clear 30 seconds after fault recovered.

TABLE 4 Continued

Code	Diagnostic Codes/Status of Equipment	Action Required to Clear and Recover
E125	Control failed self-check, internal error, failed hardware. Will restart if error recovers. Integrated control not communicating. Covers hardware errors (flame sense circuit faults, pin shorts, etc.).	Hardware problem on the control. Cycle power on control. Replace if problem prevents service and is persistent. Critical alert. Cleared 300 seconds after fault recovered.
E200	Hard lockout - Rollout circuit open or previously open.	Correct cause of rollout trip, or replace flame rollout switch. Test furnace operation. Cleared after fault recovered.
E204	Gas valve mis-wired.	Check gas valve operation and wiring. Clears when repaired.
E205	Gas valve control relay contact shorted.	Check wiring on control and gas valve. If wiring is correct, replace control.
E206	Gas valve second-stage relay failure.	Furnace will operate on 1st stage for remainder of the heating demand. Will clear after fault recovered. If unable to operate 2nd stage, replace control.
E207	Hot surface ignitor sensed open.	Measure resistance of hot surface ignitor. Replace if open or not within specified range found in IOM. Resumes normal operation after fault is cleared.
E223	Low pressure switch failed open.	Check pressure (inches w.c.) of low pressure switch closing on heat call. Measure operating pressure (inches w.c.). Inspect vent and combustion air inducer for correct operation and restriction. Resumes normal operation after fault is cleared.
E224	Low pressure switch failed closed.	Check pressure (inches w.c.) of low pressure switch closing on heat call. Measure operating pressure (inches w.c.). Inspect vent and combustion air inducer for correct operation and restriction. Resumes normal operation after fault is cleared.
E225	High pressure switch failed open.	Check pressure (inches w.c.) of high pressure switch closing on heat call. Measure operating pressure (inches w.c.). Inspect vent and combustion air inducer for correct operation and restriction. Resumes normal operation after fault is cleared.
E226	High pressure switch failed closed.	Check operation of high pressure switch closing on heat call. Measure operating pressure (inches w.c.). Inspect vent and combustion air inducer for correct operation and restriction. Resumes normal operation after fault is cleared.
E227	Low pressure switch open during trial for ignition or run mode.	Check pressure (inches w.c.) of low pressure switch closing on heat call. Measure operating pressure (inches w.c.). Inspect vent and combustion air inducer for correct operation and restriction. Resumes normal operation after fault is cleared.
E229	Ignition on High Fire - Information Only.	Code is displayed if 1) low pressure switch fails to close, then furnace will switch to high speed inducer to close both low and high pressure switches, then furnace lights on high fire, or 2) if continuous fan is active, furnace lights on high fire for 60 seconds to improve heat exchanger warm up time.
E240	Low flame current - Run mode.	Check micro-amperes of flame sensor using control diagnostics or field-installed mode. Clean or replace sensor. Measure voltage of neutral to ground to ensure good unit ground. Alert clears after current heat call has been completed.
E241	Flame sensed out of sequence - Flame still present.	Shut off gas. Check for gas valve leak. Replace, if necessary. Alert clears when fault is recovered.
E250	Limit switch circuit open.	Check for proper firing rate on furnace. Ensure there is no blockage in heater. Check for proper air flow. If limit not closed within 3 minutes, unit will go into 1-hour soft lockout. Resumes normal operation after fault is cleared.

TABLE 4 Continued

Code	Diagnostic Codes/Status of Equipment	Action Required to Clear and Recover
E270	Soft lockout - Exceeded maximum number of retries. No flame current sensed.	Check for proper gas flow. Ensure that ignitor is lighting burner. Check flame sensor current. Clears when heat call finishes successfully.
E271	Soft lockout - Exceeded maximum number of retries. Last retry failed due to the pressure switch opening.	Check pressure (inches w.c.) of low pressure switch closing on heat call. Measure operating pressure (inches w.c.). Inspect vent and combustion air inducer for correct operation and restriction. Clears when heat call finishes successfully.
E272	Soft lockout - Exceeded maximum number of recycles. Last recycle due to the pressure switch opening.	Check operation of low pressure switch to see if it is stuck closed on heat call. Check pressure (inches w.c.) of high pressure switch closing on heat call. Measure operating pressure (inches w.c.). Inspect vent and combustion air inducer for correct operation and restriction. Clears when heat call finishes successfully.
E273	Soft lockout - Exceeded maximum number of recycles. Last recycle due to flame failure.	Check micro-amperes of flame sensor using control diagnostics or field-installed mode. Clean or replace sensor. Measure voltage of neutral to ground to ensure good unit ground. Clears when heat call finishes successfully.
E274	Soft lockout - Exceeded maximum number of recycles. Last recycle failed due to the limit circuit opening or limit remained open longer than 3 minutes.	Shut down system. 1-hour soft lockout. Check firing rate and air flow. Check for blockage. Clears when heat call finishes successfully.
E275	Soft lockout - Flame sensed out of sequence. Flame signal is gone.	Shut off gas. Check for gas valve leak. 1-hour soft lockout. Clears when flame has been proven stable.
E290	Ignitor circuit fault - Failed ignitor or triggering circuitry.	Measure resistance of hot surface ignitor. Replace if open or not within specifications. 1-hour soft lockout. Clears when flame has been proven stable.

Integrated Control DIP Switches

Units are equipped with a two-stage integrated control. This control manages ignition timing, heating mode fan off delays and indoor blower speeds based on selections made using the control dip switches and jumpers.

The control includes an internal watchdog feature which automatically resets the ignition control when it has been locked out. After one hour of continuous thermostat demand for heat, the watchdog will break and remake thermostat demand to the furnace and automatically reset the control to relight the furnace.

Heating Operation DIP Switch Settings

Switch 1 -- Thermostat Selection -- This unit may be used with either a single-stage or two-stage thermostat. The thermostat selection is made using a DIP switch which must be properly positioned for the particular application. The DIP switch is factory-positioned for use with a two-stage thermostat. If a single-stage thermostat is to be used, the DIP switch must be repositioned.

- Select "OFF" for two-stage heating operation controlled by a two-stage heating thermostat (factory setting);
- Select "ON" for two-stage heating operation controlled by a single-stage heating thermostat. This setting provides a timed delay before second-stage heat is initiated.

Switch 2 --- Second Stage Delay (Used with Single-Stage Thermostat Only) -- This switch is used to determine the second stage on delay when a single-stage thermostat is being used. The switch is factory-set in the OFF position, which provides a 7-minute delay before second-stage heat is initiated. If the switch is toggled to the ON position, it will provide a 12-minute delay before second-stage heat is initiated. This switch is only activated when the thermostat selector jumper is positioned for SINGLE-stage thermostat use.

Indoor Blower Operation DIP Switch Settings

Switches 3 and 4 -- Heating Mode Blower-Off Delay --

The blower-on delay of 30 seconds is not adjustable. The blower-off delay (time that the blower operates after the heating demand has been satisfied) can be adjusted by moving switches 3 and 4 on the integrated control. The unit is shipped from the factory with a blower-off delay of 90 seconds.

The blower off delay affects comfort and is adjustable to satisfy individual applications. Adjust the blower off delay to achieve a supply air temperature between 90° and 110°F at the exact moment that the blower is de-energized. Longer off delay settings provide lower supply air temperatures; shorter settings provide higher supply air temperatures. TABLE 5 provides the blower off timings that will result from different switch settings.

TABLE 5

Blower Off Heating Mode Delay Switch Settings

Blower Off Delay Seconds	Switch 3	Switch 4
60	On	Off
90 (factory)	Off	Off
120	Off	On
180	On	On

Switch 5 -- Cooling Mode Blower-Off Delay-- The unit is shipped from the factory with the dip switch positioned OFF for a 45 second delay. TABLE 6 provides the cooling mode off delay settings.

TABLE 6

Blower Off Cooling Mode Delay Switch Settings

Blower Off Delay Seconds	Switch 5
45 (factory)	Off
2	On

Switches 6 and 7 -- Continuous Fan Mode -- Continuous fan speed can be controlled by changing DIP switch positions. TABLE 7 provides DIP switch settings for continuous fan mode.

TABLE 7

Continuous Fan Mode Settings

Continuous Fan Mode	Switch 6	Switch 7
Low Heat Speed (factory setting)	Off	Off

On-Board Link W914 Dehum

On-board link W914, is a clippable connection between terminals R and DS on the integrated control. W914 must be cut when the furnace is installed with a thermostat which features humidity control. If the link is not cut, terminal "DS" will remain energized not allowing the blower to reduce to low cool speed upon a call for dehumidification.

On-Board Link W951 Heat Pump (R to O)

On-board link W951 is a clippable connection between terminals R and O on the integrated control. W951 must be cut when the furnace is installed in applications which include a heat pump unit and a thermostat which features dual fuel use. If the link is left intact, terminal "O" will remain energized eliminating the HEAT MODE in the heat pump.

On-Board Link W915 2 Stage Compr (Y1 to Y2)

On-board link W915 is a clippable connection between terminals Y1 and Y2 on the integrated control. W915 must be cut if two-stage cooling will be used. If the Y1 to Y2 link is not cut the outdoor unit will operate in second-stage cooling only.

B- Indoor Blower Motor

! IMPORTANT

Each blower is statically and dynamically balanced as an assembly before installation in the unit.

Units are equipped with a constant torque ECM motor. It has a DC motor coupled to an electronic control module both contained in the same motor housing. The motor is programmed to provide constant torque at each of the five selectable speed taps. Each tap requires 24 volts to energize.

Input Voltage Requirements

The circuit is designed to be operated with AC voltage. To enable a tap requires 12 to 33VAC. Expected current draw will be less than 20mA.

Troubleshooting the Motor

Troubleshooting the motor is an easy process. Follow steps below.

- 1 - Shut off power to unit.
- 2 - Remove input plugs P48 and P49 from motor. See FIGURE 9 for troubleshooting procedure.

If correct voltage is present in tests 1 and 2 and motor is not operating properly, replace motor. The motor is not field repairable.

If replacing the indoor blower motor or blower wheel is necessary, placement is critical. The blower wheel must be centered in the blower housing as shown in FIGURE 7. When replacing the indoor blower motor the set screw must be aligned and tightened with the motor shaft as shown in FIGURE 8.

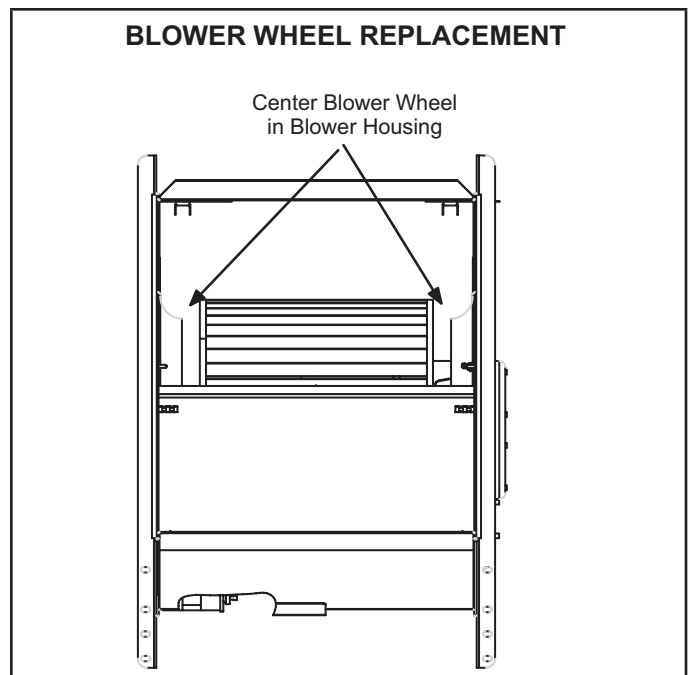

FIGURE 7

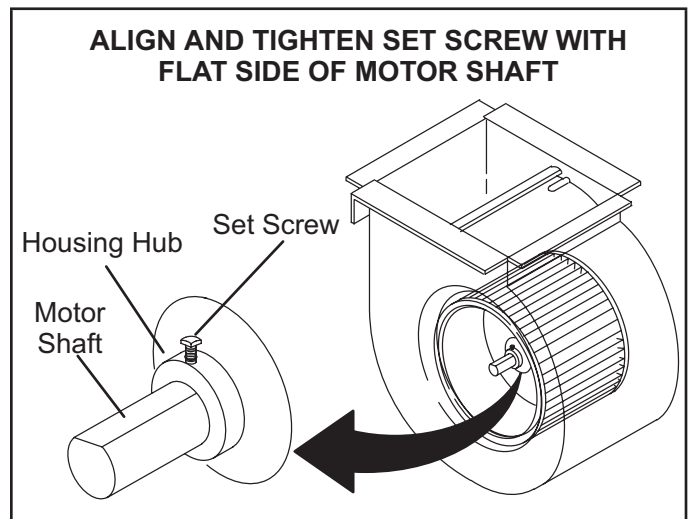
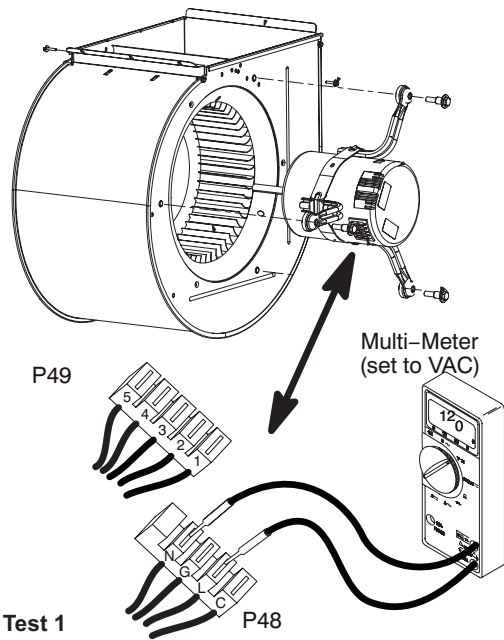
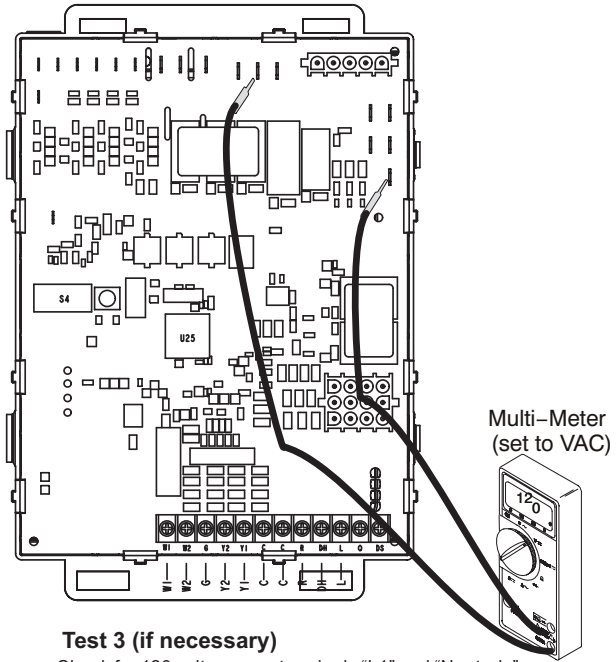

FIGURE 8



Test 1

Turn on power to unit. Check for 120 volts across terminals "L" and "N" on input plug P48. If voltage is present continue to test 2. If voltage is not present problem may be may be up stream of plug P48 and proceed to test 3.



Test 3 (if necessary)

Check for 120 volts across terminals "L1" and "Neutrals" on the integrated control. If voltage is present, problem is with the harness. If voltage is not present problem may be may be with the integrated control.

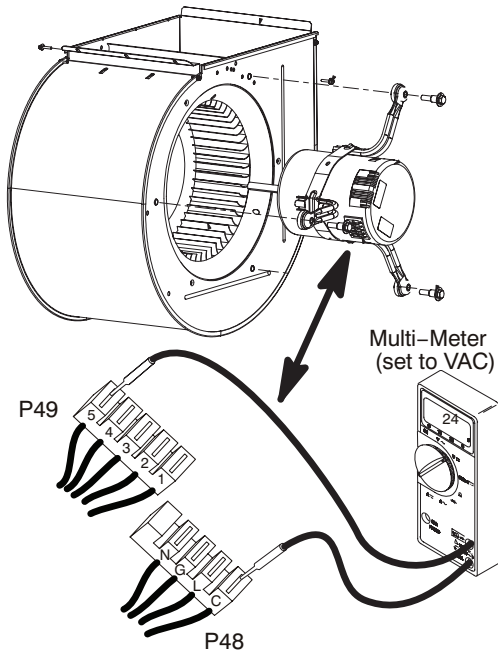

Test 2

Switch thermostat to CONTINUOUS FAN MODE. Check for 24 volts across terminal "C" on input plug P48 and speed tap used for continuous fan. (1, 2, 3, 4 or 5) on input plug P49. If 24 volts is not present problem may be up stream of plug P49. Proceed to test 4.

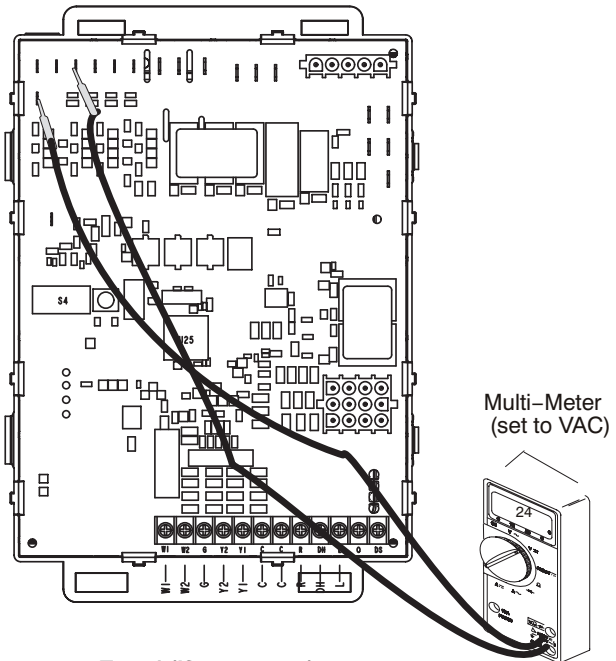

Test 4 (if necessary)

Check for 24 volts across terminals "24 COM" and the "active speed tap" on the integrated control. If voltage is present, problem is with the harness. If voltage is not present problem may be may be with the integrated control

FIGURE 9

Replacing the Motor Module

- 1 - Disconnect electrical power to unit.
- 2 - Remove unit access panel.
- 3 - Unplug the two harnesses from the motor control module. See FIGURE 10.

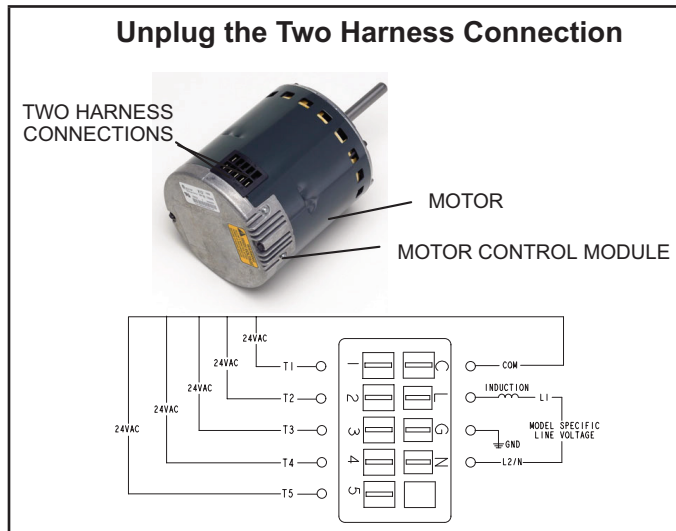

FIGURE 10

- 4 - Remove the two hex head bolts securing the motor control module to the motor (FIGURE 11).



FIGURE 11

- 5 - Slide the motor control module away from the motor to access and disconnect the internal three wire connector. It is not necessary to remove blower motor itself. Set both hex head bolts aside.

Testing the Motor (FIGURE 12)

If any motor fails the below tests, do not install the new control module. The motor is defective and it also must be replaced. The new control can fail if placed on a defective motor.

- 1 - Using an ohmmeter check the resistance from any one of the motor connector pins to the aluminum end plate of the motor. This resistance should be greater than 100k ohms.
- 2 - Check the resistances between each of the three motor connector pins. These should all read approximately the same resistance within an ohm.
- 3 - Check to see if the blower wheel spins freely.

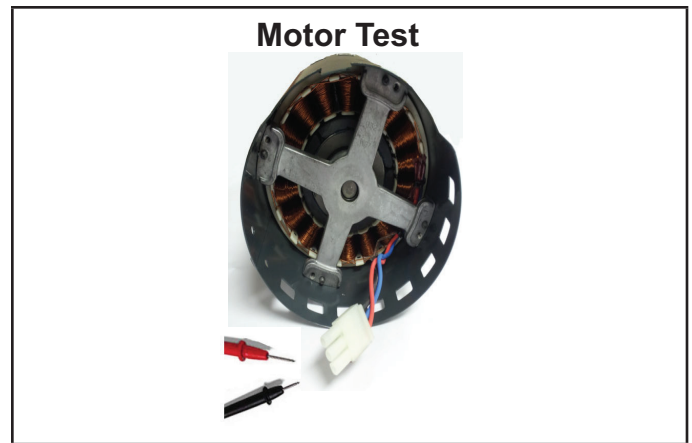

FIGURE 12

TABLE 8

Scale	Measurement range in words	ohms
2 M	two megohm-two million ohms	0 - 2,000,000
200 K	two hundred kilo-ohm-two hundred thousand ohms	0 - 200,000
20 K	twenty kilo-ohm-twenty thousand ohms	0 - 20,000
2 K	two kilo-ohm two-thousand ohms	0 - 2,000
200	two hundred ohms	0 - 200

Motor Module Installation

All replacement motor control modules look similar; however, each module is designed for a specific motor size. It is very important to make sure that you are using the correct replacement motor control module. **USE OF THE WRONG MOTOR CONTROL MODULE MAY RESULT IN UNEXPECTED UNIT OPERATION.**

- 1 - Verify electrical power to unit is disconnected.
- 2 - Connect three-wire harness from motor to control module.
- 3 - Mount new motor control module to motor using two hex head bolts removed in figure 10. Torque bolts to 22 inch pounds or 1/16th clock wise turn.
- 4 - Reconnect the two harnesses to the motor control module.
- 5 - The electrical connectors of the motor should be facing down to form a drip loop (FIGURE 13). This will direct moisture away from the motor and its electric connections on the motor.

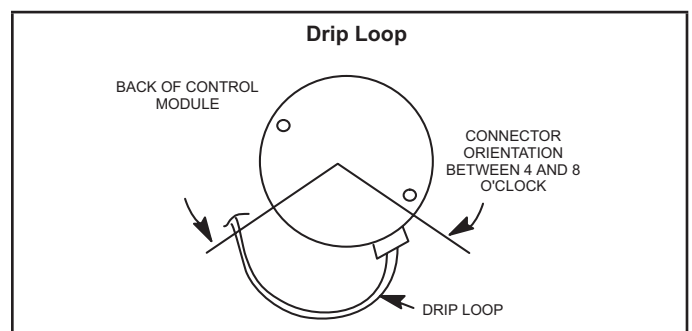

FIGURE 13

C- Heating Components

1. Ignitor

The SureLight® ignitor is made of durable silicon nitride. The integrated control provides 120 volts to the ignitor for consistent ignition and long ignitor life. Ohm value should be 39 to 70. See FIGURE 15 for ignitor location and FIGURE 16 for ignitor check out.

NOTE - The EL296DFE furnace contains electronic components that are polarity sensitive. Make sure that the furnace is wired correctly and is properly grounded.

2. Flame Sensor

A flame sensor is located on the left side of the burner support. See FIGURE 14. The sensor tip protrudes into the flame envelope of the left-most burner. The sensor can be removed for service without removing any part of the burners.

During operation, flame is sensed by current passed through the flame and sensing electrode. The SureLight control allows the gas valve to remain open as long as flame signal is sensed. To check flame sense signal use the push-button found on the integrated control and go to Field Test Mode. The menu will display the flame signal. See TABLE 9 for flame signal.

TABLE 9
Flame Signal in Microamps

Normal	Low	Drop Out
2.6 or greater	2.5 or less	.06

3. Gas Valve

The valve (FIGURE 15) is internally redundant to assure safety shut-off. If the gas valve must be replaced, the same type valve must be used. 24VAC terminals and gas control knob are located on the valve. A wire harness connects the terminals from the gas valve to the electronic ignition control. 24V applied to the terminals energizes the valve.

Inlet and outlet pressure taps are located on the valve. A regulator adjustment screw is located on the valve. LPG change over kits are available from Lennox. Kits include burner orifices and a gas valve.

4. Flame Rollout Switches (S47)

Flame rollout switch is a high temperature limit located on top of the burner box, one on each side.- See figure 14. The limit is a N.C. SPST manual-reset limit. When S47 senses rollout, the circuit breaks and the ignition control immediately stops ignition and closes the gas valve. Rollout can be caused by a blocked heat exchanger, flue or lack of combustion air. The wswitch is factory set to trip (open) at 210°F and cannot be adjusted. The switch can be manually reset. To manually reset a tripped switch, push the reset button located on the control.

5. Burners

All units use inshot burners. Burners are factory set and require no adjustment. Always operate the unit with the burner box front panel in place. Each burner uses an orifice that is precisely matched to the burner input. Burners can be removed as a one piece assembly for service. If burner assembly has been removed, it is critical to align center of each burner to the center of the clamshell when re-installing. See more detail in Section VI- MAINTENANCE.

6. Primary Limit Control (S10)

The primary limit (S10) is located in the heating vestibule panel. When excess heat is sensed in the heat exchanger, the limit will open. If the limit is open, the furnace control energizes the supply air blower and closes the gas valve. The limit automatically resets when unit temperature returns to normal. The switch must reset within three minutes or the SureLight control will go into Watch guard for one hour. The switch is factory set and cannot be adjusted.

The switch may have a different set point for each unit model number. See Lennox Repair Parts Handbook if limit switch must be replaced. When removing switch make note of orientation. When replacing switch make sure the three mounting holes are lined up with the screw holes in the vestibule for correct orientation.

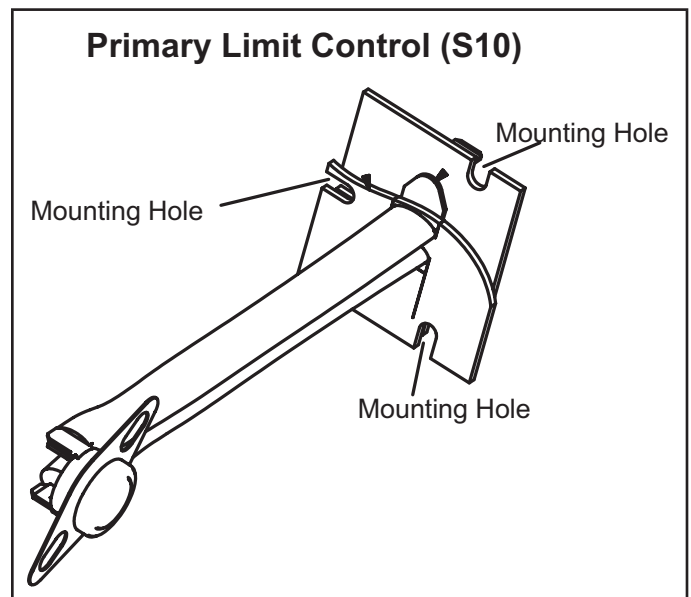

FIGURE 14

HEATING COMPONENTS

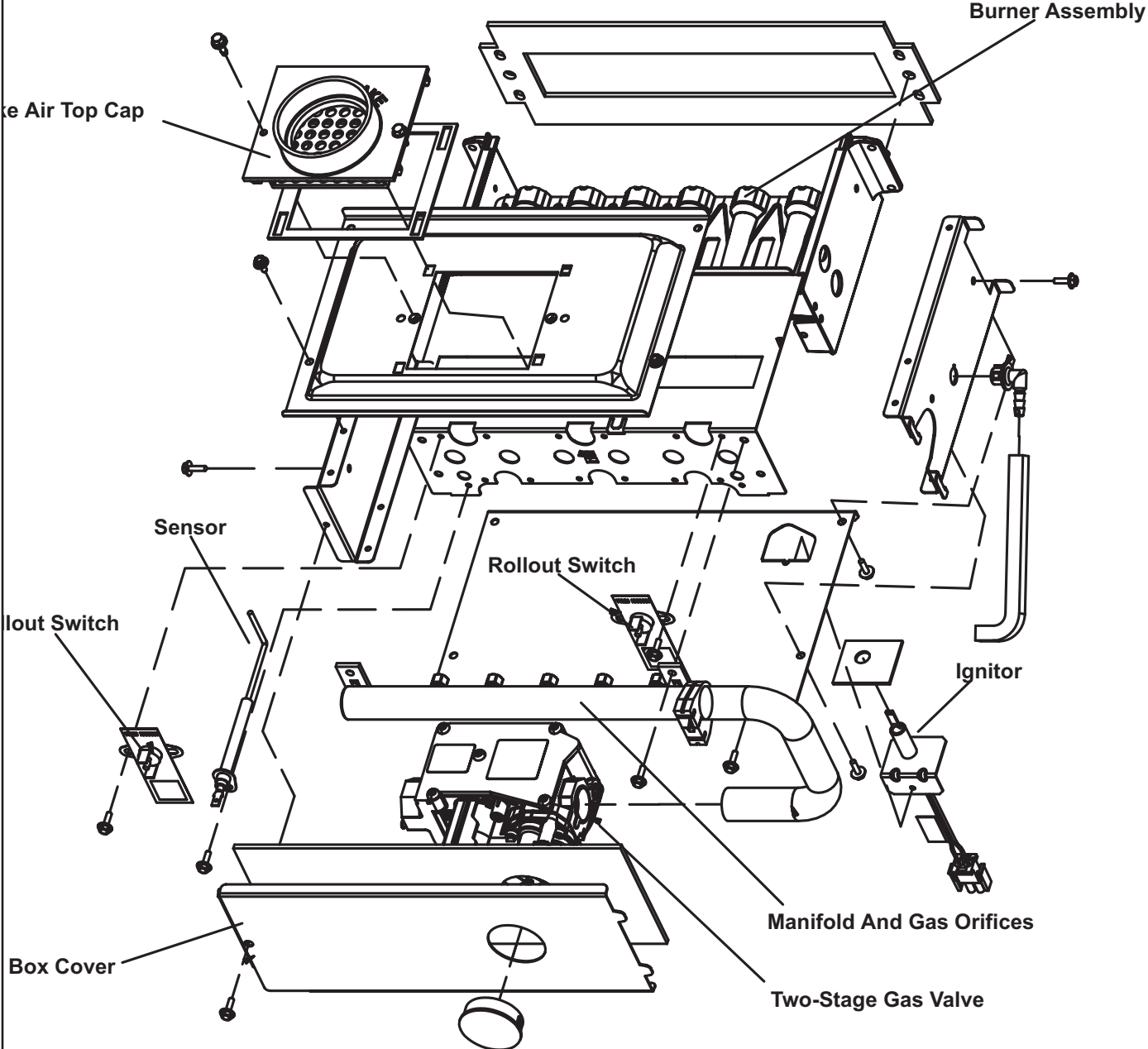
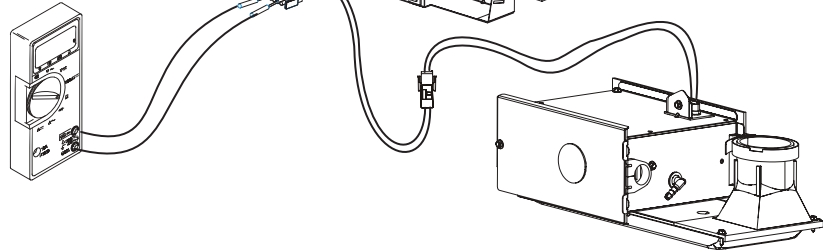

FIGURE 15

Ignitor Check

Test 1
Check ignitor circuit for correct resistance.
Remove 5-pin plug from control.
Check ohms reading across terminals 1 and 5.
If value is correct, this is the only test needed.
If the reading on the meter is not correct, (0 or infinity) then a second test is needed.

Meter
(set to ohms)



Test 2
Check ignitor for correct resistance.
Separate the 2-pin jack-plug near the manifold and check resistance of ignitor at the plug. Reading should be between 39 and 70 ohms. If the reading is correct, then the problem is with the wiring between the jack-plug and the control. If reading is not correct, the issue is the ignitor.

Meter
(set to ohms)



Test 3
Check ignitor for correct voltage
Insert meter probes into terminals 1 and 5 (use small diameter probes in order not to damage plug).
Check voltage during 20 second ignitor warm up period.
Voltage should read 120 volts \pm 10%. If voltage reads below these values, check for correct supply voltage to furnace.

Meter
(set to AC volts)



FIGURE 16

7. Combustion Air Inducer (B6) and Cold End Header Box

All units use a two-speed combustion air inducer to move air through the burners and heat exchanger during heating operation. The blower uses a 120VAC motor. The motor operates during all heating operation and is controlled by integrated control control A92. The inducer also operates for 15 seconds before burner ignition (pre-purge) and for 5 seconds after the gas valve closes (post-purge).

The inducer operates on low speed during first-stage heat, then switches to high speed for second stage heat. The combustion air inducer is installed on the cold end header box (CEHB). The cold end header box is a single piece made of hard plastic. The box has an internal channel where the combustion air inducer creates negative pressure at unit start up. The channel contains an orifice used to regulate flow created by the combustion air inducer. The box has pressure taps for the combustion air inducer pressure switch hoses. The pressure switch measures the pressure differential across the cold end header box orifice or difference in the channel and the box. **If replacement is necessary the gaskets used to seal the box to the vestibule panel and the combustion air inducer to the box, must also be replaced.**

A pressure switch measures the pressure differential across the CEHB orifice to prove inducer operation. The CEHB orifice will be different for each model. See TABLE 10 for orifice sizes. When the proving switch opens, the furnace control (A92) immediately closes the gas valve to prevent burner operation.

TABLE 10

Unit	CEHB Orifice Size
-045	0.618
070-1, -2	0.810
-070-3 and later	0.920
-090	0.920
-110	1.040

8. Combustion Air Inducer Pressure Switch (S18) (FIGURE 17)

Units are equipped with a dual combustion air pressure switch (first and second stage) located on the CEHB. The switch is connected to the cold end header box by means of flexible silicone hoses. It monitors negative differential pressure across the cold end header box orifice.

The switches are a single-pole single-throw pressure switches electrically connected to the integrated control. The purpose of the switches is to prevent burner operation if the combustion air inducer is not operating, the inlet or exhaust pipes or heat exchanger are restricted. On heat demand (first or second stage) the switch senses that the combustion air inducer is operating. It closes a circuit to the integrated control when pressure across the CEHB orifice becomes greater then the switch set point

Set points vary depending on unit size. See TABLE 11, TABLE 12 and TABLE 13. Both pressures sensed by the switches are negative relative to atmospheric pressure. If the inlet or exhaust pipes, or the heat exchanger become obstructed, the switch senses the loss of differential pressure and opens the circuit to the furnace integrated control and gas valve. A bleed port on the switch allows relatively dry air in the vestibule to purge switch tubing, to prevent condensate build up.

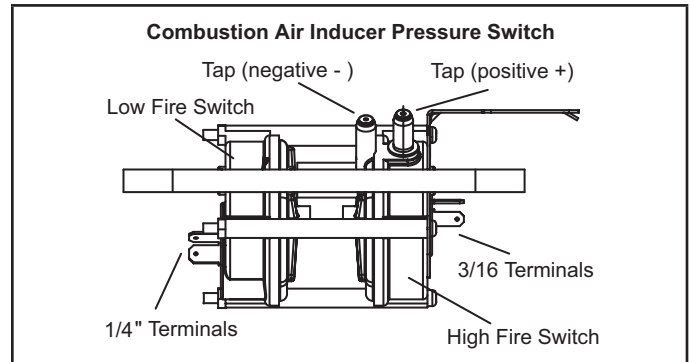

FIGURE 17

NOTE - The switch is factory set and is not field adjustable. It is a safety shut-down control in the furnace and must not be by-passed for any reason. If switch is closed or bypassed, the control will not initiate ignition at start up.

TABLE 11

0- 4500'

Unit	Set Point Low Heat	Set Point High Heat
-045	0.35	0.60
-070-1, -2	0.45	0.90
-070-3 & later	0.45	0.81
-090	0.50	0.90
-110	0.45	0.90

TABLE 12

4501 - 7500'

Unit	Set Point Low Heat	Set Point High Heat
-045	0.35	0.55
-070-1, -2	0.45	0.81
-070-3 & later	0.45	0.70
-090	0.50	0.85
-110	0.45	0.81

TABLE 13

7501 - 10,000'

Unit	Set Point Low Heat	Set Point High Heat
-045	0.35	0.50
-070-1, -2	0.41	0.74
-070-3 & later	0.40	0.65
-090	0.45	0.81
-110	0.41	0.74

II-PLACEMENT AND INSTALLATION

All pipe, fittings, primer and solvent cement must conform with American National Standard Institute and the American Society for Testing and Materials (ANSI/ASTM) standards. The solvent shall be free flowing and contain no lumps, undissolved particles or any foreign matter that adversely affects the joint strength or chemical resistance of the cement. The cement shall show no gelation, stratification, or separation that cannot be removed by stirring. Refer to TABLE 14 for approved piping and fitting materials.

**TABLE 14
PIPING AND FITTINGS SPECIFICATIONS**

Schedule 40 PVC (Pipe)	D1785
Schedule 40 PVC (Cellular Core Pipe)	F891
Schedule 40 PVC (Fittings)	D2466
Schedule 40 CPVC (Pipe)	F441
Schedule 40 CPVC (Fittings)	F438
SDR-21 PVC or SDR-26 PVC (Pipe)	D2241
SDR-21 CPVC or SDR-26 CPVC (Pipe)	F442
Schedule 40 ABS Cellular Core DWV (Pipe)	F628
Schedule 40 ABS (Pipe)	D1527
Schedule 40 ABS (Fittings)	D2468
ABS-DWV (Drain Waste & Vent) (Pipe & Fittings)	D2661
PVC-DWV (Drain Waste & Vent) Pipe & Fittings)	D2665
PRIMER & SOLVENT CEMENT	ASTM SPECIFICATION
PVC & CPVC Primer	F656
PVC Solvent Cement	D2564
CPVC Solvent Cement	F493
ABS Solvent Cement	D2235
PVC/CPVC/ABS All Purpose Cement For Fittings & Pipe of the same material	D2564, D2235, F493
ABS to PVC or CPVC Transition Solvent Cement	D3188
CANADA PIPE & FITTING & SOLVENT CEMENT	MARKING
PVC & CPVC Pipe and Fittings	ULCS636
PVC & CPVC Solvent Cement	
POLYPROPYLENE VENTING SYSTEM	
PolyPro® by Duravent	ULCS636
InnoFlue® by Centrotherm	
UL 1738 CERTIFIED GAS VENTING SYSTEM	UL1738
IPEX System1738 Schedule 40 PVC Pipes and Fittings	
IPEX System1738 PVC FGV Cement & Primer	

TABLE 14 Continued

CANADA PIPE & FITTING & SOLVENT CEMENT	MARKING
POLYPROPYLENE VENTING SYSTEM	ULCS636
PolyPro® by Duravent	
InnoFlue® by Centrotherm	

IMPORTANT

Exhaust and intake connections are made of PVC. Use PVC primer and solvent cement when using PVC vent pipe. When using ABS vent pipe, use transitional solvent cement to make connections to the PVC fittings in the unit.

Use PVC primer and solvent cement or ABS solvent cement meeting ASTM specifications, refer to TABLE 14. As an alternate, use all purpose cement, to bond ABS, PVC, or CPVC pipe when using fittings and pipe made of the same materials. Use transition solvent cement when bonding ABS to either PVC or CPVC.

Low temperature solvent cement is recommended during cooler weather. Metal or plastic strapping may be used for vent pipe hangers. Uniformly apply a liberal coat of PVC primer for PVC or use a clean dry cloth for ABS to clean inside socket surface of fitting and male end of pipe to depth of fitting socket.

Canadian Applications Only - Pipe, fittings, primer and solvent cement used to vent (exhaust) this appliance must be certified to ULC S636 and supplied by a single manufacturer as part of an approved vent (exhaust) system. In addition, the first three feet of vent pipe from the furnace flue collar must be accessible for inspection.

Venting Options

The EL296DFE is shipped with vent exhaust / air intake connection at the top cap. See FIGURE 18. Using parts provided, the furnace may be field modified to have these connections on the right side of the furnace cabinet. See FIGURE 20 and follow the steps below. For left side venting order kit 87W73.

- 1 - Remove inner blower door.
- 2 - Loosen hose clamps which attach rubber fittings to the white PVC pipes inside the vestibule area. See FIGURE 18.
- 3 - Loosen the clamp which secures the pipes at the blower deck. See FIGURE 18.
- 4 - Remove white PVC pipes, slide up and out thru the top cap.
- 5 - Remove the black plastic fitting in top cap which previously aligned the PVC pipes.
- 6 - Remove the remaining parts of the pipe clamp at the blower deck.
- 7 - Remove the sheet metal patch plate on the side of the cabinet which covers the openings for side venting option. Save screws for reuse.

- 8 - Re-use the patch plate to cover the hole in the top cap. See FIGURE 19. Remove the 2 screws which secure the top cap to the furnace on the right side and re-install securing the right edge of the patch plate and the right side of the top cap to the furnace. Use 2 self-drilling sheet metal screws (provided) to finish securing the left edge of the patch plate on the left side.
- 9 - Use a utility knife to cut out the cabinet insulation for the right side vent / air intake. 10 -Install the two 90° street elbows (provided) through the side of the cabinet. The male side of each elbow should extend down through the blower deck and connect to the rubber fittings below. Once the elbows are properly positioned, tighten each clamp.
- 10 - Install the two 90° street elbows (provided) through the side of the cabinet. The male side of each elbow should extend down through the blower deck and connect to the rubber fittings below. Once the elbows are properly positioned, tighten each clamp.
- 11 - Peel protective backing from side vent sealing gaskets (2) and apply to side vent sealing plates (2) as shown in FIGURE 20.
- 12 - Install the side vent sealing plates and gaskets on the exterior of the cabinet as shown in FIGURE 20. Secure with six mounting screws (four reused and two provided from bag assembly). Holes are pre-punched in the parts and cabinet, no drilling is required.
- 13 - Install sheet metal screws (provided) to seal extra two holes in cabinet not used with side vent clamps

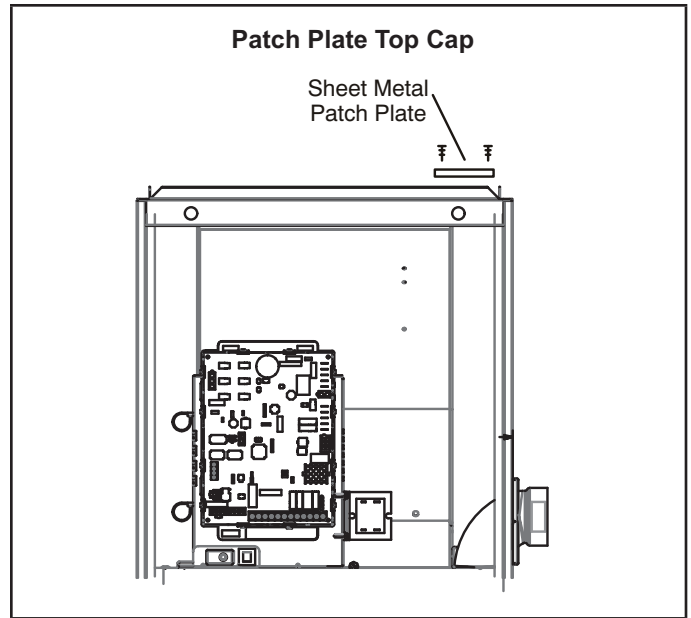

FIGURE 19

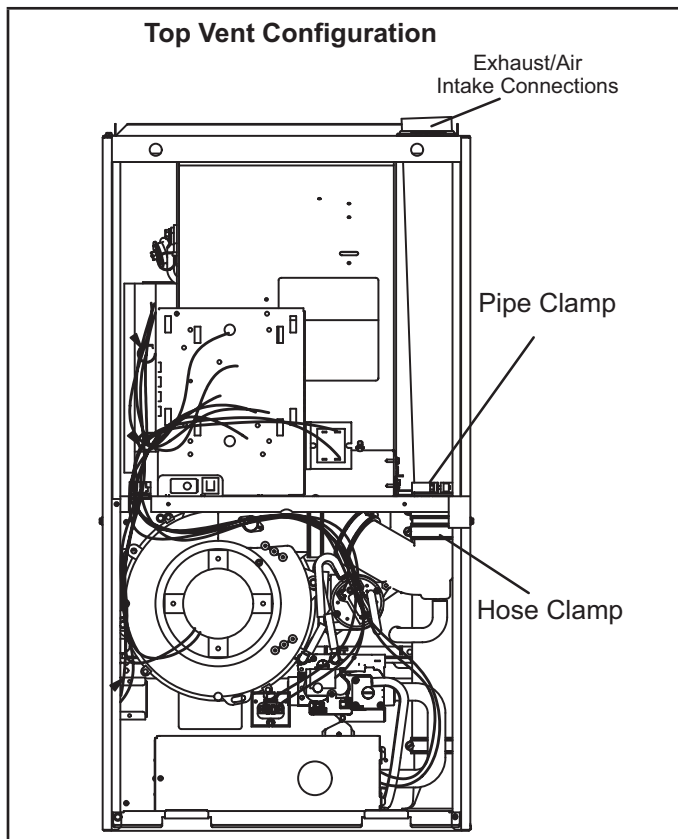

FIGURE 18

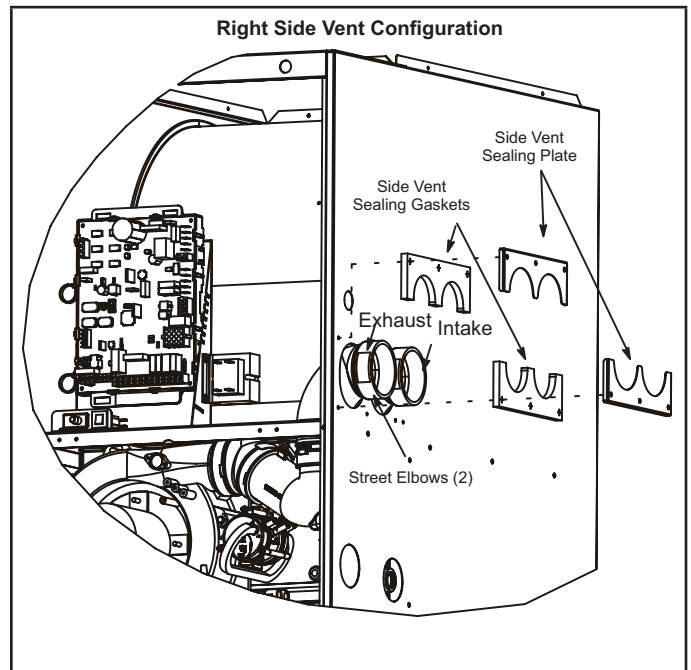

FIGURE 20

⚠ IMPORTANT
 Side vent sealing plates and side vent sealing gaskets must be used when converting to right side venting. Failure to use gaskets and plates may lead to improper operation of unit.

**TABLE 15
OUTDOOR TERMINATION USAGE***

Input Size	Vent Pipe Dia. in.	STANDARD				CONCENTRIC		
		Flush Mount Kit	Wall Kit		Field Fabricated	1-1/2 inch	2 inch	3 inch
			2 inch	3 inch		71M80 (US) ⁴ 44W92 (CA)	69M29 (US) ⁴ 44W92 (CA)	60L46 (US) ⁴ 44W93 (CA)
045	⁶ 1-1/2	³ YES	YES	¹ YES	⁵ YES	² YES		
	2	³ YES	YES	¹ YES	⁵ YES	² YES	N/A	N/A
	2-1/2	³ YES	YES	¹ YES	⁵ YES	² YES		
	3	³ YES	YES	¹ YES	⁵ YES	² YES		
070	⁶ 1-1/2	³ YES	YES	¹ YES	⁵ YES	² YES		
	2	³ YES	YES	¹ YES	⁵ YES	² YES		
	2-1/2	³ YES	YES	¹ YES	⁵ YES	² YES		
	3	³ YES	YES	¹ YES	⁵ YES	² YES		
090	2	³ YES	N/A	YES	⁵ YES	N/A	YES	YES
	2-1/2	³ YES		YES	⁵ YES		YES	YES
	3	³ YES		YES	⁵ YES		YES	YES
110	2	YES		YES	⁵ YES		YES	YES
	2-1/2	YES		YES	⁵ YES		YES	YES
	3	YES		YES	⁵ YES		YES	YES

NOTE - Standard Terminations do not include any vent pipe or elbows external to the structure. Any vent pipe or elbows external to the structure must be included in total vent length calculations. See vent length tables.

* Kits must be properly installed according to kit instructions.

¹Requires field-provided outdoor 1-1/2" exhaust accelerator.

²Concentric kits 71M80 and 44W92 include 1-1/2" outdoor accelerator, when used with 045 and 070 input models. 1-1/2 in. pipe must be transitioned to 2 in. when used with a concentric kit,

³ Flush mount kit 51W11 and 51W12 includes 1-1/2 in. outdoor exhaust accelerator, required when used with 045, 070 and 090 input models. 1-1/2 in. pipe must be transitioned to 2 in. pipe when used with the flushmount kit.

⁴ Termination kits 30G28, 44W92, 4493 and 81J20 are certified to ULC S636 for use in Canada only.

⁵ See table 10 for vent accelerator requirements.

⁶ 2 in to 1-1/2 in reducer required must be field provided.

Joint Cementing Procedure

All cementing of joints should be done according to the specifications outlined in ASTM D 2855.

NOTE - A sheet metal screw may be used to secure the intake pipe to the connector, if desired. Use a drill or self tapping screw to make a pilot hole.

! DANGER

DANGER OF EXPLOSION!

Fumes from PVC glue may ignite during system check. Allow fumes to dissipate for at least 5 minutes before placing unit into operation.

- 1 - Measure and cut vent pipe to desired length.
- 2 - Debur and chamfer end of pipe, removing any ridges or rough edges. If end is not chamfered, edge of pipe may remove cement from fitting socket and result in a leaking joint.

NOTE - Check the inside of vent pipe thoroughly for any obstruction that may alter furnace operation.

- 3 - Clean and dry surfaces to be joined.
- 4 - Test fit joint and mark depth of fitting on outside of pipe.
- 5 - Uniformly apply a liberal coat of PVC primer for PVC or use a clean dry cloth for ABS to clean inside socket surface of fitting and male end of pipe to depth of fitting socket.
- 6 - Promptly apply solvent cement to end of pipe and inside socket surface of fitting. Cement should be applied lightly but uniformly to inside of socket. Take care to keep excess cement out of socket. Apply second coat to end of pipe.

NOTE - Time is critical at this stage. Do not allow primer to dry before applying cement.

- 7 - Immediately after applying last coat of cement to pipe, and while both inside socket surface and end of pipe are wet with cement, forcefully insert end of pipe into socket until it bottoms out. Turn PVC pipe 1/4 turn during assembly (but not after pipe is fully inserted) to distribute cement evenly. DO NOT turn ABS or cellular core pipe.

NOTE - Assembly should be completed within 20 seconds after last application of cement. Hammer blows should not be used when inserting pipe.

- 8 - After assembly, wipe excess cement from pipe at end of fitting socket. A properly made joint will show a bead around its entire perimeter. Any gaps may indicate an improper assembly due to insufficient solvent.
- 9 - Handle joints carefully until completely set.

Venting Practices

- 1 - In areas where piping penetrates joists or interior walls, hole must be large enough to allow clearance on all sides of pipe through center of hole using a hanger.
- 2 - When furnace is installed in a residence where unit is shut down for an extended period of time, such as a vacation home, make provisions for draining condensate collection trap and lines.

Piping Suspension Guidelines

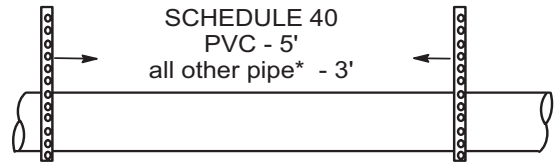

* See Piping and Fittings Specifications table

NOTE - Isolate piping at the point where it exits the outside wall or roof in order to prevent transmission of vibration to the structure.

Wall Thickness Guidelines

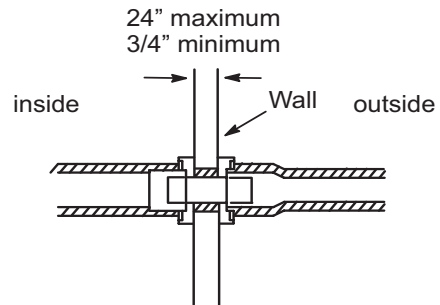
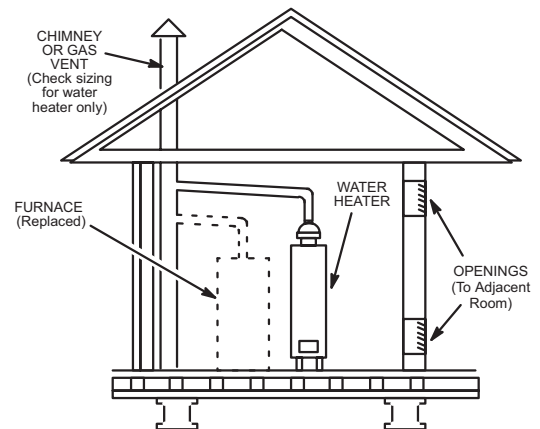

FIGURE 21

REPLACING FURNACE THAT WAS PART OF A COMMON VENT SYSTEM



If replacing a furnace which was commonly vented with another gas appliance, the size of the existing vent pipe for that gas appliance must be checked. Without the heat of the original furnace flue products, the existing vent pipe is probably oversized for the single water heater or other appliance. The vent should be checked for proper draw with the remaining appliance.

FIGURE 22

Removal of the Furnace from Common Vent

In the event that an existing furnace is removed from a venting system commonly run with separate gas appliances, the venting system is likely to be too large to properly vent the remaining attached appliances. Conduct the following test while each appliance is operating and the other appliances (which are not operating) remain connected to the common venting system. If the venting system has been installed improperly, you must correct the system as indicated in the general venting requirements section.

WARNING

CARBON MONOXIDE POISONING HAZARD

Failure to follow the steps outlined below for each appliance connected to the venting system being placed into operation could result in carbon monoxide poisoning or death.

The following steps shall be followed for each appliance connected to the venting system being placed into operation, while all other appliances connected to the venting system are not in operation:

- 1 - Seal any unused openings in the common venting system.
- 2 - Inspect the venting system for proper size and horizontal pitch. Determine that there is no blockage, restriction, leakage, corrosion, or other deficiencies which could cause an unsafe condition.
- 3 - Close all building doors and windows and all doors between the space in which the appliances remaining connected to the common venting system are located and other spaces of the building. Turn on clothes dryers and any appliances not connected to the common venting system. Turn on any exhaust fans, such as range hoods and bathroom exhausts, so they will operate at maximum speed. Do not operate a summer exhaust fan. Close fireplace dampers dryers and any appliances not connected to the common venting system. Turn on any exhaust fans, such as range hoods and bathroom exhausts, so they will operate at maximum speed. Do not operate a summer exhaust fan. Close fireplace dampers.
- 4 - Follow the lighting instructions. Turn on the appliance that is being inspected. Adjust the thermostat so that the appliance operates continuously.

- 5 - After the main burner has operated for 5 minutes, test for leaks of flue gases at the draft hood relief opening. Use the flame of a match or candle.
- 6 - After determining that each appliance connected to the common venting system is venting properly, (step 3) return all doors, windows, exhaust fans, fireplace dampers, and any other gas-burning appliances to their previous mode of operation.
- 7 - If a venting problem is found during any of the preceding tests, the common venting system must be modified to correct the problem.

Resize the common venting system to the minimum vent pipe size determined by using the appropriate tables in Appendix G. (These are in the current standards of the National Fuel Gas Code ANSI Z223.1. Exhaust Piping (FIGURE 24 and FIGURE 26) Route piping to outside of structure. Continue with installation following instructions given in piping termination section.

Exhaust Piping (FIGURE 24 and FIGURE 26)

Route piping to outside of structure. Continue with installation following instructions given in piping termination section.

WARNING

Carbon Monoxide Poisoning Hazard

Cutting or altering exhaust or air intake pipes, which are located in the blower compartment, could result in Carbon Monoxide Poisoning or Death.

CAUTION

Do not discharge exhaust into an existing stack or stack that also serves another gas appliance. If vertical discharge through an existing unused stack is required, insert PVC pipe inside the stack until the end is even with the top or outlet end of the metal stack.

CAUTION

The exhaust vent pipe operates under positive pressure and must be completely sealed to prevent leakage of combustion products into the living space.

Vent Piping Guidelines

NOTE - Lennox has approved the use of DuraVent® and Centrotherm manufactured vent pipe and terminations as an option to PVC. When using the PolyPro® by DuraVent or InnoFlue® by Centrotherm venting system the vent pipe requirements stated in the unit installation instruction – minimum & maximum vent lengths, termination clearances, etc. – apply and must be followed. Follow the instructions provided with PolyPro by DuraVent and InnoFlue by Centrotherm venting system for assembly or if requirements are more restrictive. The PolyPro by DuraVent and InnoFlue by Centrotherm venting system must also follow the uninsulated and unconditioned space criteria listed in table 19.

The EL296DFE can be installed as either a Non-Direct Vent or a Direct Vent gas central furnace.

NOTE - In Non-Direct Vent installations, combustion air is taken from indoors or ventilated attic or crawlspace and flue gases are discharged outdoors. In Direct Vent installations, combustion air is taken from outdoors and flue gases are discharged outdoors.

Intake and exhaust pipe sizing -- Size pipe according to TABLE 16 (minimum length permitted) and TABLE 17 (maximum length permitted). Count all elbows inside and outside the home.

**TABLE 16
MINIMUM VENT PIPE LENGTHS**

EL296DFE MODEL	MIN. VENT LENGTH*
045, 070, 090, 110	15 ft or 5ft plus 2 elbows or 10 ft plus 1 elbow

*Any approved termination may be added to the minimum length listed. Two 45 degree elbows are equivalent to one 90 degree elbow.

Regardless of the diameter of pipe used, the standard roof and wall terminations described in section Exhaust Piping Terminations should be used. Exhaust vent termination pipe is sized to optimize the velocity of the exhaust gas as it exits the termination. Refer to TABLE 20.

In some applications which permit the use of several different sizes of vent pipe, a combination vent pipe may be used. Contact Lennox' Application Department for assistance in sizing vent pipe in these applications.

⚠ IMPORTANT

Do not use screens or perforated metal in exhaust or intake terminations. Doing so will cause freeze-ups and may block the terminations.

NOTE - It is acceptable to use any pipe size which fits within the guidelines allowed in TABLE 17.

NOTE - All horizontal runs of exhaust pipe must slope back toward unit. A minimum of 1/4" (6mm) drop for each 12" (305mm) of horizontal run is mandatory for drainage.

NOTE - Exhaust pipe **MUST** be glued to furnace exhaust fittings.

NOTE - Exhaust piping should be checked carefully to make sure there are no sags or low spots.

NOTE - If right side venting option is used, you must include the elbow at the furnace in the elbow count. If transitioning to 3" dia pipe, this elbow equates to 20' of equivalent vent length for all models.

Use the following steps to correctly size vent pipe diameter.

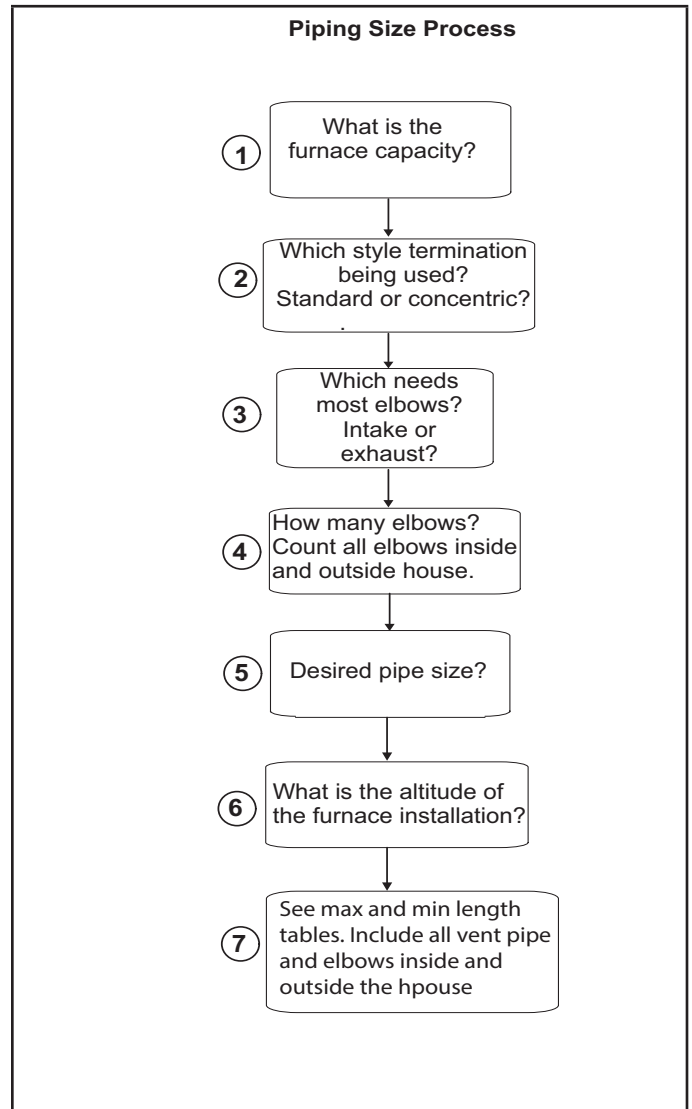

FIGURE 23

NOTE - Lennox offers a glueless vent adapter kit 17H92 as an option for exhaust exiting at the furnace top cap coupling.

TABLE 17

Maximum Allowable Intake or Exhaust Vent Length

Size intake and exhaust pipe length separately. Values in table are for Intake OR Exhaust, not combined total. Intake and Exhaust must be same size.
 NOTE - Additional vent pipe and elbows used to terminate the vent pipe outside the structure must be included in the total vent length calculation.

Standard Termination at Elevation 0 - 4500 ft																
Number Of 90° Elbows Used	1-1/2" Pipe				2" Pipe				2-1/2" Pipe				3" Pipe			
	Model				Model				Model				Model			
	045	070	090	110	045	070	090	110	045	070	090	110	045	070	090	110
1	20	15	n/a	n/a	71	56	34	14	105	105	83	48	128	127	108	108
2	15	10			66	51	29	9	100	100	78	43	123	122	103	103
3	10	n/a			61	46	24	4	95	95	73	38	118	117	98	98
4	n/a				56	41	19	n/a	90	90	68	33	113	112	93	93
5					51	36	14		85	85	63	28	108	107	88	88
6					46	31	9		80	80	58	23	101	102	83	83
7					41	26	4		75	75	53	18	98	97	78	78
8					36	21	n/a		70	70	48	13	93	92	73	73
9					31	16			65	65	43	8	88	87	68	68
10					26	11			60	60	38	3	83	82	63	63

Standard Termination Elevation 4501 - 10,000 ft																
Number Of 90° Elbows Used	1-1/2" Pipe				2" Pipe				2-1/2" Pipe				3" Pipe			
	Model				Model				Model				Model			
	045	070	090	110	045	070	090	110	045	070	090	110	045	070	090	110
1	20	15	n/a	n/a	71	56	34	n/a	105	105	83	48	128	127	108	108
2	15	10			66	51	29		100	100	78	43	123	122	103	103
3	10	n/a			61	46	24		95	95	73	38	118	117	98	98
4	n/a				56	41	19		90	90	68	33	113	112	93	93
5					51	36	14		85	85	63	28	108	107	88	88
6					46	31	9		80	80	58	23	103	102	83	83
7					41	26	4		75	75	53	18	98	97	78	78
8					36	21	n/a		70	70	48	13	93	92	73	73
9					31	16			65	65	43	8	87	87	68	68
10					26	11			60	60	38	5	83	82	63	63

Concentric Termination at Elevation 0 - 4500 ft																
Number Of 90° Elbows Used	1-1/2" Pipe				2" Pipe				2-1/2" Pipe				3" Pipe			
	Model				Model				Model				Model			
	045	070	090	110	045	070	090	110	045	070	090	110	045	070	090	110
1	15	10	n/a	n/a	63	48	32	12	95	95	79	44	111	111	104	104
2	10	n/a			58	43	27	7	90	90	74	39	106	106	99	99
3	n/a				53	38	22	2	85	85	69	34	101	101	94	94
4					48	33	17	n/a	80	80	64	29	96	96	89	89
5					43	28	12		75	75	59	24	91	91	84	84
6					38	23	7		70	70	54	19	86	86	79	79
7					33	18	2		65	65	49	14	81	81	74	74
8					28	13	n/a		60	60	44	9	76	76	69	69
9					23	8			55	55	39	4	71	71	64	64
10		18			3	50			50	34	n/a	66	66	59	59	

TABLE 17 Continued

Concentric Termination Elevation 4501 - 10,000 ft

Number Of 90° Elbows Used	1-1/2" Pipe				2" Pipe				2-1/2" Pipe				3" Pipe															
	Model				Model				Model				Model															
	045	070	090	110	045	070	090	110	045	070	090	110	045	070	090	110												
1	15	10	n/a	n/a	63	48	32	n/a	95	95	79	44	111	111	104	94												
2	10	n/a			n/a	58	43		27	n/a	90	90	74	39	106	106	99	99										
3	n/a					n/a	n/a		53		38	22	n/a	85	85	69	34	101	101	94	94							
4									48		33	17		n/a	80	80	64	29	96	96	89	89						
5									43		28	12			n/a	75	75	59	24	91	91	84	84					
6									38		23	7				n/a	70	70	54	19	86	86	79	79				
7									33		18	2					n/a	65	65	49	14	81	81	74	74			
8									28		13	n/a						n/a	60	60	44	9	76	76	69	69		
9									23		8								n/a	n/a	55	55	39	4	71	71	64	64
10									18		3										n/a	n/a	50	50	34	n/a	66	66

TABLE 18

Maximum Allowable Exhaust Vent Length Using Ventilated Attic or Crawl Space For Intake Air in Feet

NOTE - Additional vent pipe and elbows used to terminate the vent pipe outside the structure must be included in the total vent length calculation.

Standard Termination at Elevation 0 - 10,000 ft																														
Number Of 90° Elbows Used	1-1/2" Pipe				2" Pipe				2-1/2" Pipe				3" Pipe																	
	Model				Model				Model				Model																	
	045	070	090	110	045	070	090	110	045	070	090	110	045	070	090	110														
1	15	10	n/a	n/a	61	46	24	n/wa	90	90	68	33	108	107	88	88														
2	10	n/a			n/a	56	41		19	n/wa	85	85	63	28	103	102	83	83												
3	n/a					n/a	n/a		51		36	14	n/wa	80	80	58	23	98	97	78	78									
4									46		31	9		n/wa	75	75	53	18	93	92	73	73								
5									41		26	4			n/wa	70	70	48	13	88	87	68	68							
6									36		21	n/a				n/wa	65	65	43	8	81	82	63	63						
7									31		16						n/wa	n/wa	60	60	38	3	78	77	58	58				
8									26		11								n/wa	n/wa	55	55	33	n/a	73	72	53	53		
9									21		6	n/wa									n/wa	50	50		28	n/a	68	67	48	48
10									16		1											n/wa	n/wa		45		45	23	n/a	63

TYPICAL EXHAUST PIPE CONNECTIONS

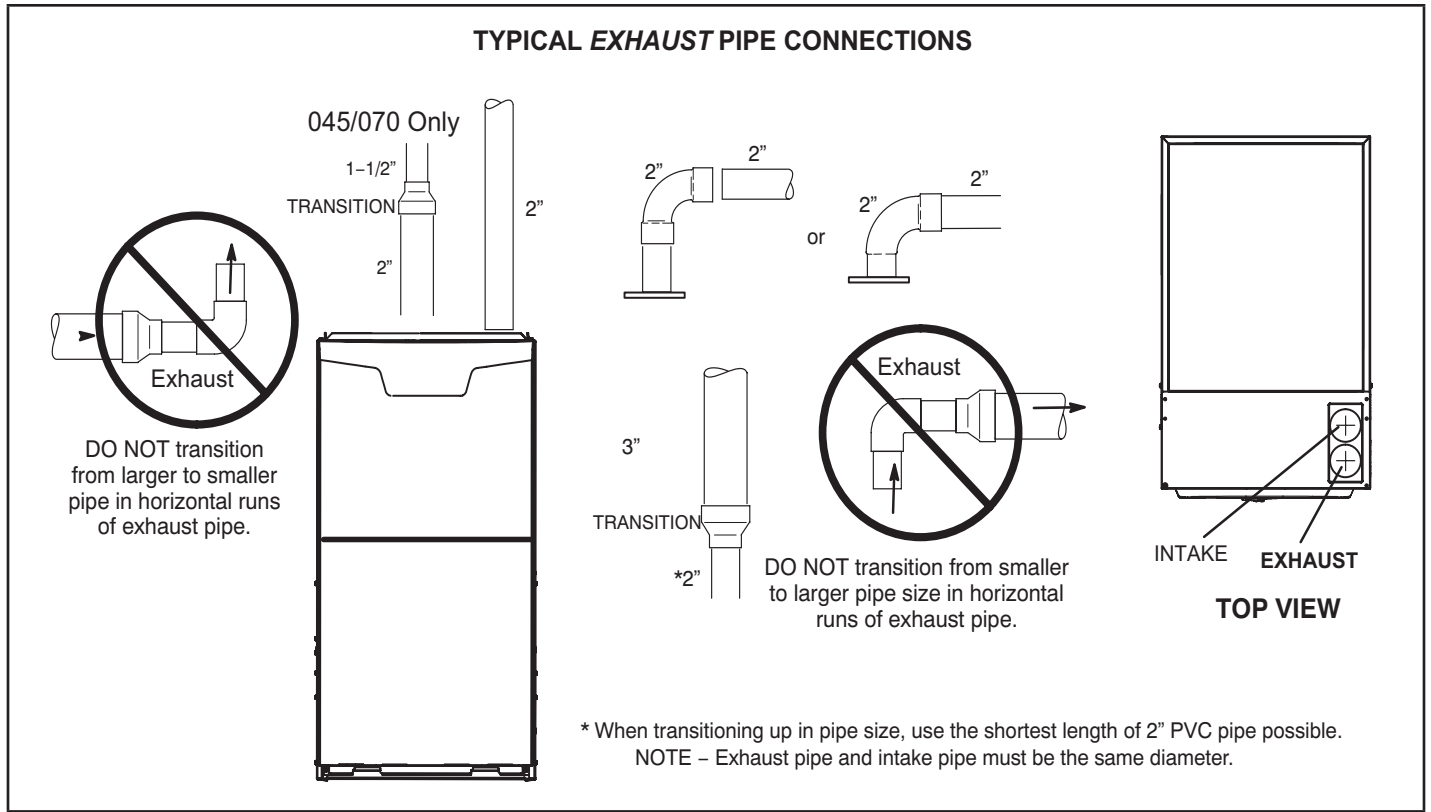

FIGURE 24

TYPICAL INTAKE PIPE CONNECTIONS

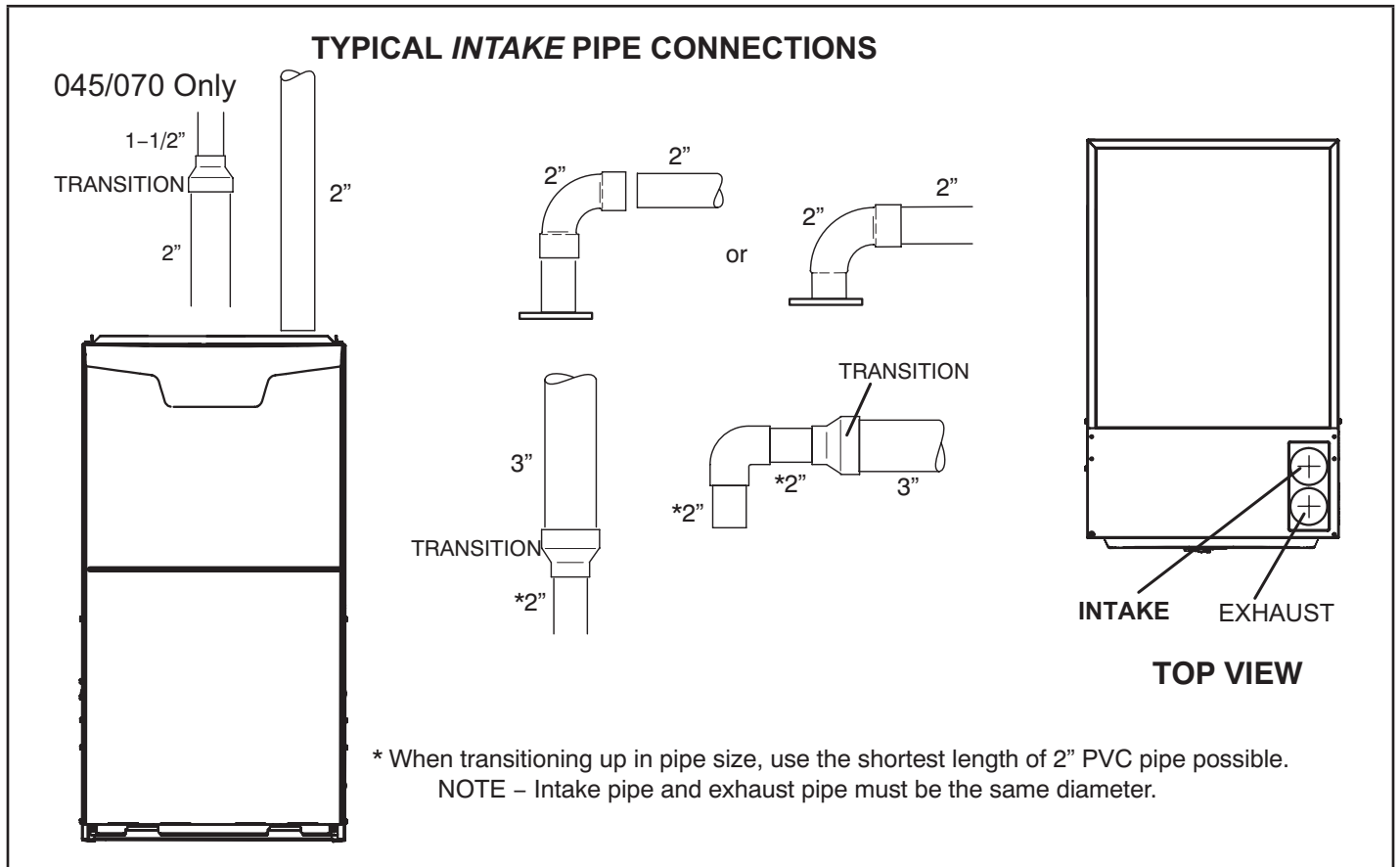
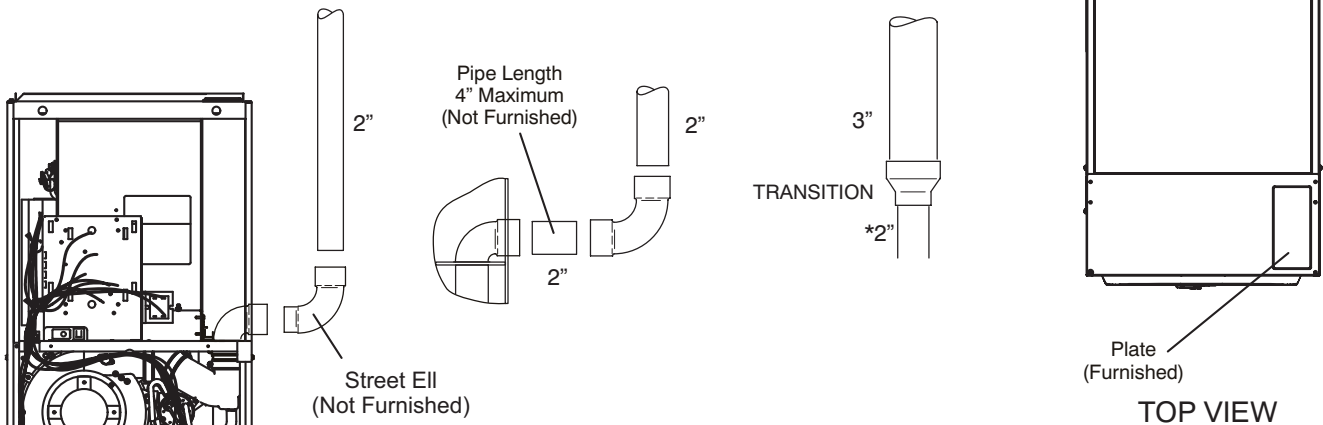

FIGURE 25

TYPICAL EXHAUST CONNECTIONS WITH RIGHT SIDE VENT OPTION



* When transitioning up in pipe size, use the shortest length of 2" PVC pipe possible.
NOTE - Intake pipe and exhaust pipe must be the same diameter.

FIGURE 26

TYPICAL AIR INTAKE PIPE CONNECTIONS WITH RIGHT SIDE VENT OPTION

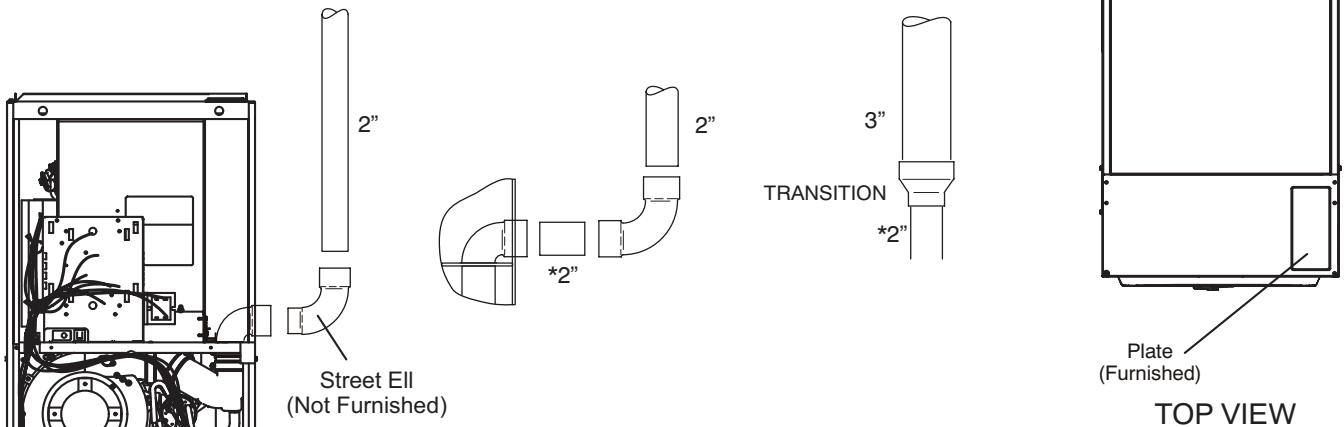

* When transitioning up in pipe size, use the shortest length of 2" PVC pipe possible.
NOTE - Intake pipe and exhaust pipe must be the same diameter.

FIGURE 27

Intake Piping

The EL296DFE furnace may be installed in either **direct vent** or **non-direct vent** applications. In non-direct vent applications, when intake air will be drawn into the furnace from the surrounding space, the indoor air quality must be considered. Guidelines listed in Combustion, Dilution and Ventilation Air section must be followed.

Follow the next two steps when installing the unit in **Direct Vent applications**, where combustion air is taken from outdoors and flue gases are discharged outdoors. **The provided air intake screen must not be used in direct vent applications (outdoors).**

- 1 - Use cement or a sheet metal screw to secure the intake pipe to the inlet air connector.
- 2 - 2 - If intake air is drawn from a ventilated crawlspace (FIGURE 28) or ventilated attic (FIGURE 29) the exhaust vent length must not exceed those listed in TABLE 19. If 3" diameter pipe is used, reduce to 2" diameter pipe to accommodate the debris screen.
- 3 - 3 - Route piping to outside of structure. Continue with installation following instructions given in general guide lines for piping terminations and intake and exhaust piping terminations for direct vent sections. Refer to TABLE 17 for pipe sizes.

CAUTION

If this unit is being installed in an application with combustion air coming in from a space serviced by an exhaust fan, power exhaust fan, or other device which may create a negative pressure in the space, take care when sizing the inlet air opening. The inlet air opening must be sized to accommodate the maximum volume of exhausted air as well as the maximum volume of combustion air required for all gas appliances serviced by this space.

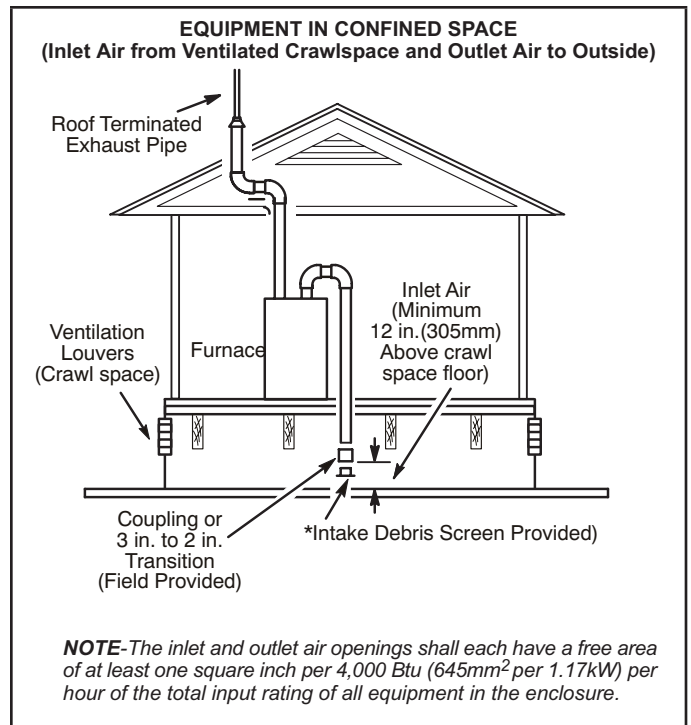

FIGURE 28

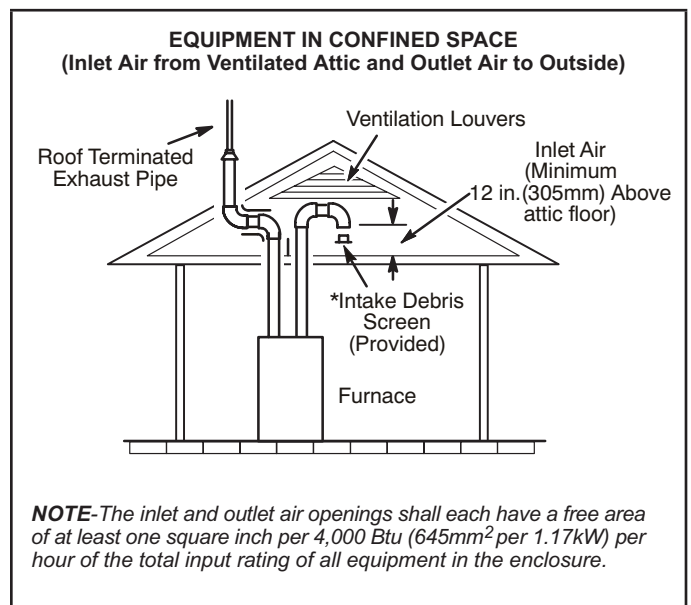

FIGURE 29

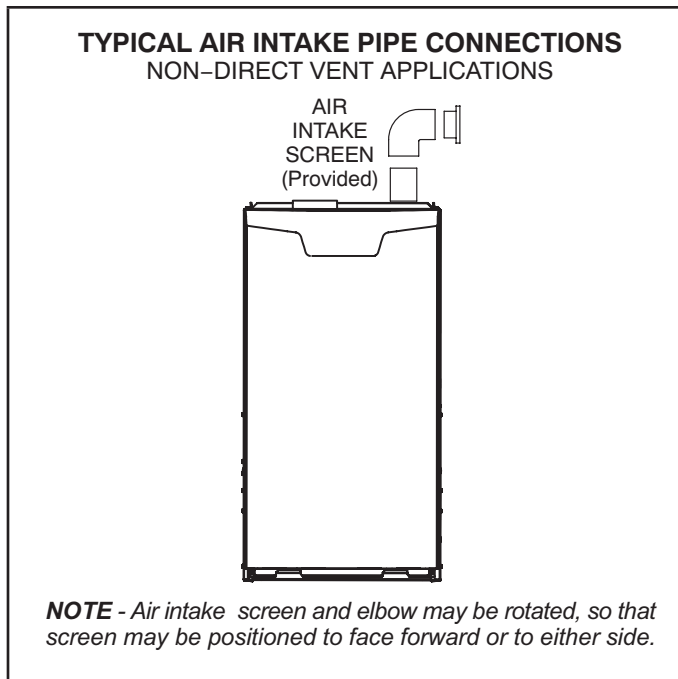

FIGURE 30

Follow the next two steps when installing the unit in **Non-Direct Vent** applications where combustion air is taken from indoors and flue gases are discharged outdoors.

- 1 - Use field-provided materials and the factory-provided air intake screen to route the intake piping as shown in FIGURE 30. Maintain a minimum clearance of 3" (76mm) around the air intake opening. The air intake opening (with the protective screen) should always be directed forward, or sideways.
- 2 - Use cement to secure the intake pipe to the connector, if desired.

General Guidelines for Vent Terminations

In Non-Direct Vent applications, combustion air is taken from indoors and the flue gases are discharged to the outdoors. The EL296DFE is then classified as a non-direct vent, Category IV gas furnace. In Direct Vent applications, combustion air is taken from outdoors and the flue gases are discharged to the outdoors.

The EL296DFE is then classified as a direct vent, Category IV gas furnace.

In both Non-Direct Vent and Direct Vent applications, the vent termination is limited by local building codes. In the absence of local codes, refer to the current National Fuel Gas Code ANSI Z223-1/NFPA 54 in U.S.A., and current CSA-B149 Natural Gas and Propane Installation Codes in Canada for details.

Position termination according to location given in FIGURE 32 or FIGURE 33. In addition, position termination so it is free from any obstructions and 12" above the average snow accumulation.

At vent termination, care must be taken to maintain protective coatings over building materials (prolonged exposure to exhaust condensate can destroy protective coatings). It is recommended that the exhaust outlet not be located within 6 feet (1.8m) of a condensing unit because the condensate can damage the painted coating.

NOTE - See TABLE 19 for maximum allowed exhaust pipe length without insulation in unconditioned space during winter design temperatures below 32°F (0°C). If required exhaust pipe should be insulated with 1/2" (13mm) Armaflex or equivalent. In extreme cold climate areas, 3/4" (19mm) Armaflex or equivalent may be necessary. Insulation must be protected from deterioration. Armaflex with UV protection is permissible. Basements or other enclosed areas that are not exposed to the outdoor ambient temperature and are above 32 degrees F (0°C) are to be considered conditioned spaces.

! IMPORTANT

Do not use screens or perforated metal in exhaust terminations. Doing so will cause freeze-ups and may block the terminations.

! IMPORTANT

For Canadian Installations Only: In accordance to CSA International B149 installation codes, the minimum allowed distance between the combustion air intake inlet and the exhaust outlet of other appliances shall not be less than 12 inches (305mm).

TABLE 19

Maximum Allowable Exhaust Vent Pipe Length (in ft.³) Without Insulation In Unconditioned Space For Winter Design Temperatures Two - Stage High Efficiency Furnace

Winter Design Temperatures ¹ °F (°C)	Vent Pipe Diameter	Unit Input Size							
		045		070		090		110	
		PVC	² PP	PVC	² PP	PVC	² PP	PVC	² PP
32 to 21 (0 to -6)	1-1/2 in	22	n/a	20	n/a	n/a	n/a	n/a	n/a
	2 in	21	18	33	30	46	42	30	30
	2-1/2 in	16	n/a	26	n/a	37	n/a	36	n/a
	3 in	12	12	21	21	30	30	29	29
20 to 1 (-7 to -17)	1-1/2 in	12	n/a	20	n/a	n/a	n/a	n/a	n/a
	2 in	11	9	19	17	28	25	27	24
	2-1/2 in	7	n/a	14	n/a	21	n/a	20	n/a
	3 in	2	2	9	9	16	16	14	14
0 to -20 (-18 to -29)	1-1/2 in	8	n/a	13	n/a	n/a	n/a	n/a	n/a
	2 in	6	4	12	10	19	16	18	15
	2-1/2 in	1	n/a	7	n/a	13	n/a	12	n/a
	3 in	1	1	2	2	8	8	7	7

¹Refer to 99% Minimum Design Temperature table provided in the current edition of the ASHRAE Fundamentals Handbook.

² Poly-Propylene vent pipe (PP) by Duravent and Centrotherm.

³ Vent length in table is equivalent length. Consider each elbow as 5ft. of linear length.

NOTE - Concentric terminations are the equivalent of 5' and should be considered when measuring pipe length.

NOTE - Maximum uninsulated vent lengths listed may include the termination(vent pipe exterior to the structure) and cannot exceed 5 linear feet or the maximum allowable intake or exhaust vent length listed in TABLE 17 or TABLE 18 which ever is less.

NOTE - If insulation is required in an unconditioned space, it must be located on the pipe closest to the furnace. See FIGURE 31.

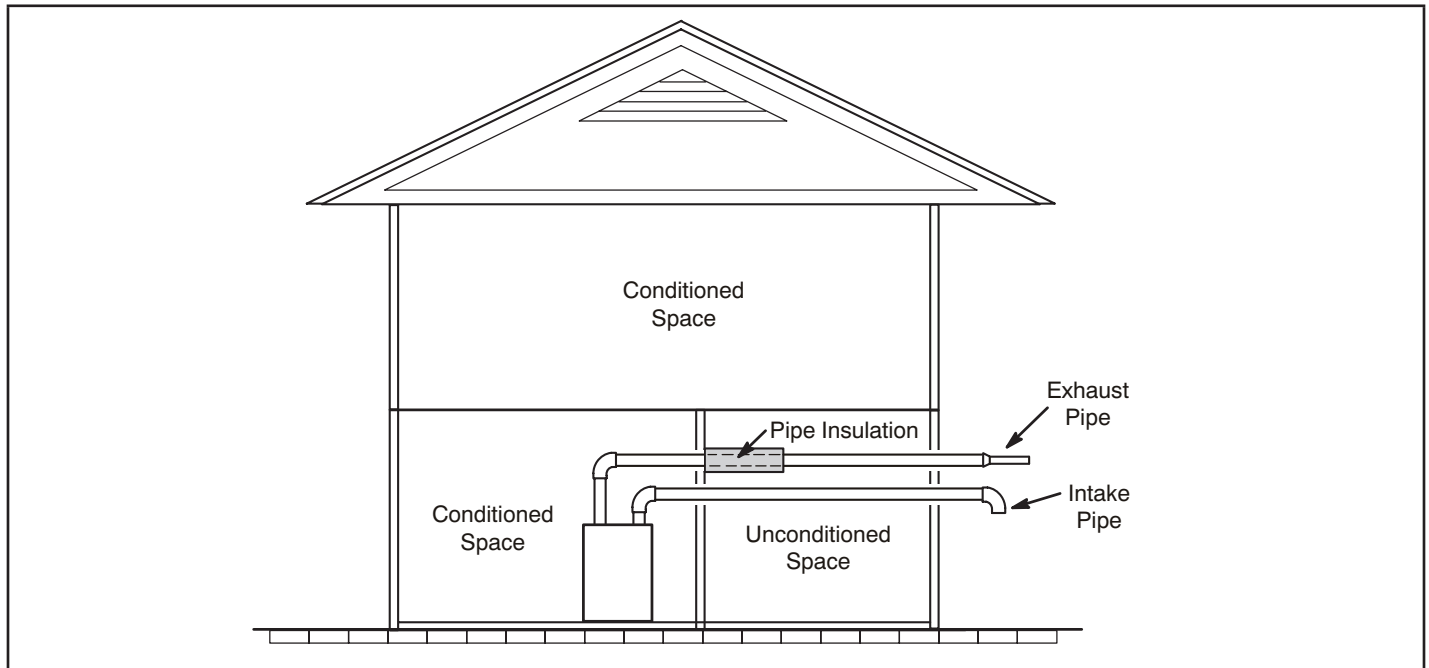
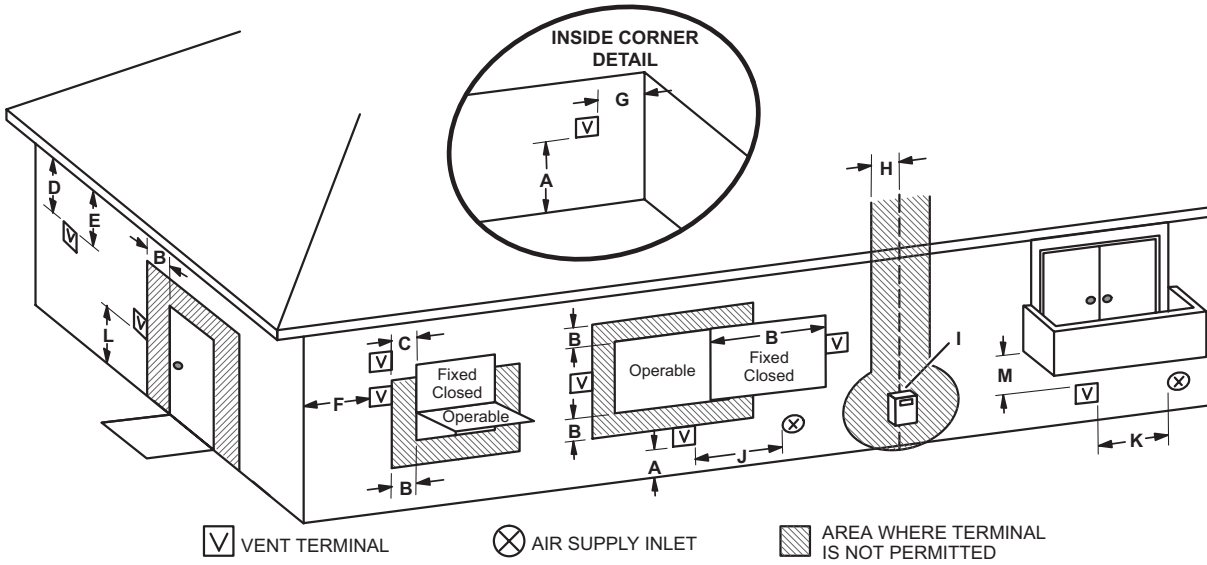

FIGURE 31

VENT TERMINATION CLEARANCES FOR NON-DIRECT VENT INSTALLATIONS IN THE US AND CANADA



	US Installations ¹	Canadian Installations ²	
A =	Clearance above grade, veranda, porch, deck or balcony	12 inches (305mm) or 12 in. (305mm) above average snow accumulation.	12 inches (305mm) or 12 in. (305mm) above average snow accumulation.
B =	Clearance to window or door that may be opened	4 feet (1.2 m) below or to side of opening; 1 foot (30cm) above opening	6 inches (152mm) for appliances <10,000 Btuh (3kw), 12 inches (305mm) for appliances > 10,000 Btuh (3kw) and <100,000 Btuh (30kw), 36 inches (.9m) for appliances > 100,000 Btuh (30kw)
C =	Clearance to permanently closed window	* 12"	* 12"
D =	Vertical clearance to ventilated soffit located above the terminal within a horizontal distance of 2 feet (610 mm) from the center line of the terminal	* Equal to or greater than soffit depth.	* Equal to or greater than soffit depth.
E =	Clearance to unventilated soffit	* Equal to or greater than soffit depth.	* Equal to or greater than soffit depth.
F =	Clearance to outside corner	* No minimum to outside corner	* No minimum to outside corner
G =	Clearance to inside corner	*	*
H =	Clearance to each side of center line extended above meter / regulator assembly	* 3 feet (.9m) within a height 15 feet (4.5m) above the meter / regulator assembly	3 feet (.9m) within a height 15 feet (4.5m) above the meter / regulator assembly
I =	Clearance to service regulator vent outlet	* 3 feet (.9m)	3 feet (.9m)
J =	Clearance to non-mechanical air supply inlet to building or the combustion air inlet to any other appliance	4 feet (1.2 m) below or to side of opening; 1 foot (30 cm) above opening	6 inches (152mm) for appliances <10,000 Btuh (3kw), 12 inches (305mm) for appliances > 10,000 Btuh (3kw) and <100,000 Btuh (30kw), 36 inches (.9m) for appliances > 100,000 Btuh (30kw)
K =	Clearance to mechanical air supply inlet	3 feet (.9m) above if within 10 feet (3m) horizontally	6 feet (1.8m)
L =	Clearance above paved sidewalk or paved driveway located on public property	7 feet (2.1m)†	7 feet (2.1m)†
M =	Clearance under veranda, porch, deck or balcony	*12 inches (305mm)‡	12 inches (305mm)‡

¹ In accordance with the current ANSI Z223.1/NFPA 54 Natural Fuel Gas Code

² In accordance with the current CSA B149.1, Natural Gas and Propane Installation Code

† A vent shall not terminate directly above a sidewalk or paved driveway that is located between two single family dwellings and serves both dwellings.

‡ Permitted only if veranda, porch, deck or balcony is fully open on a minimum of two sides beneath the floor. Lennox recommends avoiding this location if possible.

*For clearances not specified in ANSI Z223.1/NFPA 54 or CSA B149.1, clearance will be in accordance with local installation codes and the requirements of the gas supplier and these installation instructions."

FIGURE 32

VENT TERMINATION CLEARANCES FOR DIRECT VENT INSTALLATIONS IN THE US AND CANADA

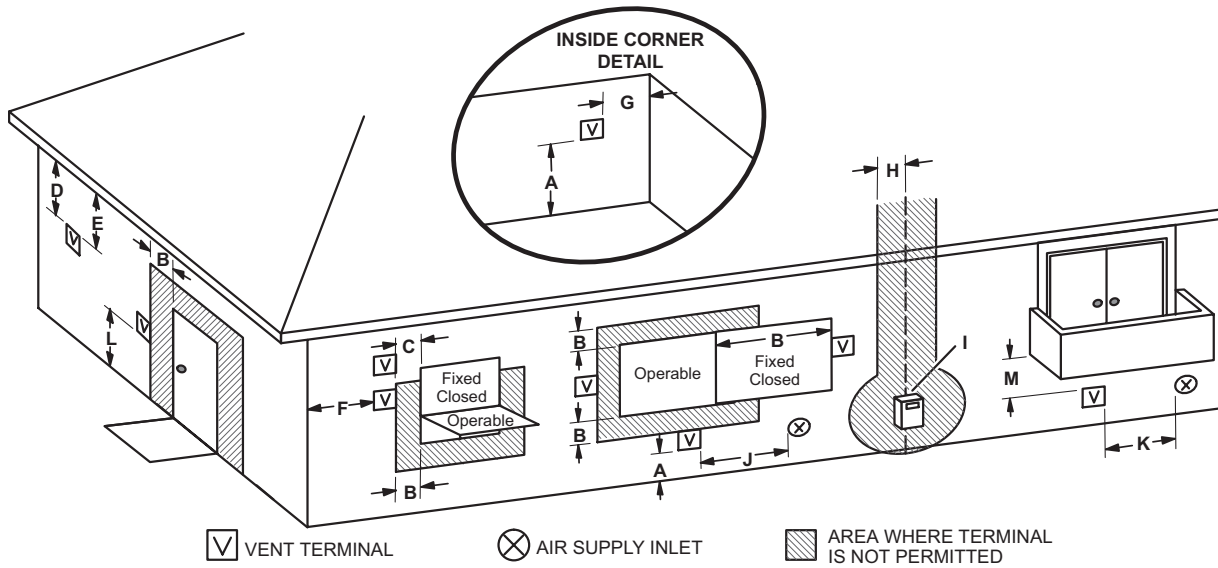

	US Installations ¹	Canadian Installations ²	
A =	Clearance above grade, veranda, porch, deck or balcony	12 inches (305mm) or 12 in. (305mm) above average snow accumulation.	12 inches (305mm) or 12 in. (305mm) above average snow accumulation.
B =	Clearance to window or door that may be opened	6 inches (152mm) for appliances <10,000 Btuh (3kw), 9 inches (228mm) for appliances > 10,000 Btuh (3kw) and <50,000 Btuh (15 kw), 12 inches (305mm) for appliances > 50,000 Btuh (15kw)	6 inches (152mm) for appliances <10,000 Btuh (3kw), 12 inches (305mm) for appliances > 10,000 Btuh (3kw) and <100,000 Btuh (30kw), 36 inches (.9m) for appliances > 100,000 Btuh (30kw)
C =	Clearance to permanently closed window	* 12"	* 12"
D =	Vertical clearance to ventilated soffit located above the terminal within a horizontal distance of 2 feet (610mm) from the center line of the terminal	* Equal to or greater than soffit depth	* Equal to or greater than soffit depth
E =	Clearance to unventilated soffit	* Equal to or greater than soffit depth	* Equal to or greater than soffit depth
F =	Clearance to outside corner	* No minimum to outside corner	* No minimum to outside corner
G =	Clearance to inside corner	*	*
H =	Clearance to each side of center line extended above meter / regulator assembly	3 feet (.9m) within a height 15 feet (4.5m) above the meter / regulator assembly	3 feet (.9m) within a height 15 feet (4.5m) above the meter / regulator assembly
I =	Clearance to service regulator vent outlet	* 3 feet (.9m)	3 feet (.9m)
J =	Clearance to non-mechanical air supply inlet to building or the combustion air inlet to any other appliance	6 inches (152mm) for appliances <10,000 Btuh (3kw), 9 inches (228mm) for appliances > 10,000 Btuh (3kw) and <50,000 Btuh (15 kw), 12 inches (305mm) for appliances > 50,000 Btuh (15kw)	6 inches (152mm) for appliances <10,000 Btuh (3kw), 12 inches (305mm) for appliances > 10,000 Btuh (3kw) and <100,000 Btuh (30kw), 36 inches (.9m) for appliances > 100,000 Btuh (30kw)
K =	Clearance to mechanical air supply inlet	3 feet (.9m) above if within 10 feet (3m) horizontally	6 feet (1.8m)
L =	Clearance above paved sidewalk or paved driveway located on public property	* 7 feet (2.1m)	7 feet (2.1m)†
M =	Clearance under veranda, porch, deck or balcony	*12 inches (305mm)‡	12 inches (305mm)‡

¹ In accordance with the current ANSI Z223.1/NFPA 54 Natural Fuel Gas Code

² In accordance with the current CSA B149.1, Natural Gas and Propane Installation Code

† A vent shall not terminate directly above a sidewalk or paved driveway that is located between two single family dwellings and serves both dwellings.

‡ Permitted only if veranda, porch, deck or balcony is fully open on a minimum of two sides beneath the floor. Lennox recommends avoiding this location if possible.

For clearances not specified in ANSI Z223.1/NFPA 54 or CSA B149.1, clearance will be in accordance with local installation codes and the requirements of the gas supplier and these installation instructions.

FIGURE 33

Details of Intake and Exhaust Piping Terminations for Direct Vent Installations

NOTE - In Direct Vent installations, combustion air is taken from outdoors and flue gases are discharged to outdoors.

NOTE - Flue gas may be slightly acidic and may adversely affect some building materials. If any vent termination is used and the flue gasses may impinge on the building material, a corrosion-resistant shield (minimum 24 inches square) should be used to protect the wall surface. If the optional tee is used, the protective shield is recommended. The shield should be constructed using wood, plastic, sheet metal or other suitable material. All seams, joints, cracks, etc. in the affected area should be sealed using an appropriate sealant. See FIGURE 42.

Intake and exhaust pipes may be routed either horizontally through an outside wall or vertically through the roof. In attic or closet installations, vertical termination through the roof is preferred. FIGURE 34 through FIGURE 41 show typical terminations.

1 - Vent terminations are not required to be in the same pressure zone. You may exit the intake on one side of the structure and the exhaust on another side (FIGURE 35). You may exit the exhaust out the roof and the intake out the side of the structure (FIGURE 36).

2 - Intake and exhaust pipes should be placed as close together as possible at termination end (refer to illustrations). Maximum separation is 3" (76mm) on roof terminations and 6" (152mm) on side wall terminations.

NOTE - When venting in different pressure zones, the maximum separation requirement of intake and exhaust pipe DOES NOT apply.

3 - On roof terminations, the intake piping should terminate straight down using two 90° elbows (FIGURE 33).

4 - Exhaust piping must terminate straight out or up as shown. A reducer may be required on the exhaust piping at the point where it exits the structure to improve the velocity of exhaust away from the intake piping. See TABLE 20.

TABLE 20

EXHAUST PIPE TERMINATION SIZE REDUCTION

EL296DFE MODEL	Termination Pipe Size
*045 and 070	1-1/2" (38MM)
*090	2" (51MM)
110	2" (51MM)

*-045, -070 and -090 units with the flush mount termination must use the 1-1/2" accelerator supplied with the kit.

5 - On field-supplied terminations for side wall exit, exhaust piping may extend a maximum of 12 inches (305mm) for 2" PVC and 20 inches (508mm) for 3" (76mm) PVC beyond the outside wall. Intake piping should be as short as possible. See FIGURE 42.

NOTE - Care must be taken to avoid recirculation of exhaust back into intake pipe.

6 - On field supplied terminations, a minimum distance between the end of the exhaust pipe and the end of the intake pipe without a termination elbow is 8" and a minimum distance of 6" with a termination elbow. See FIGURE 42.

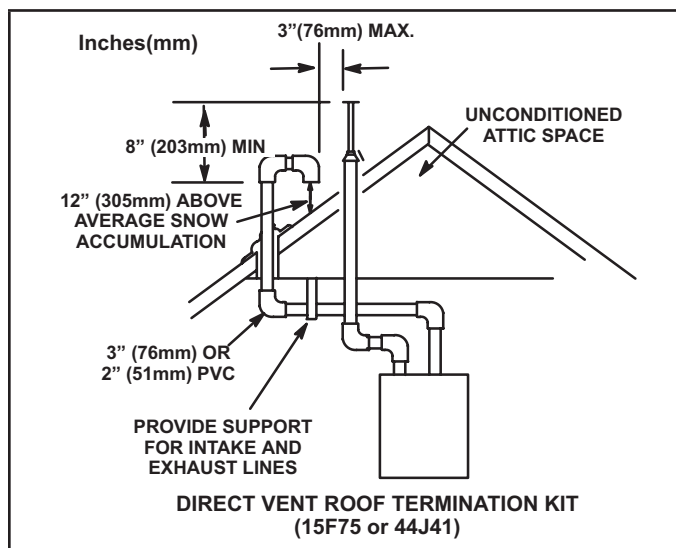

FIGURE 34

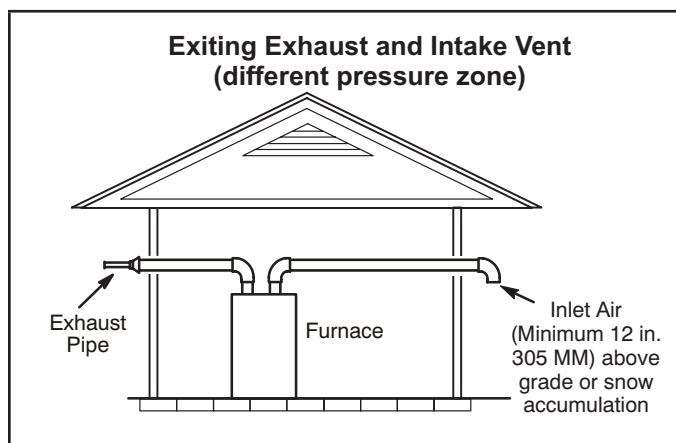

FIGURE 35

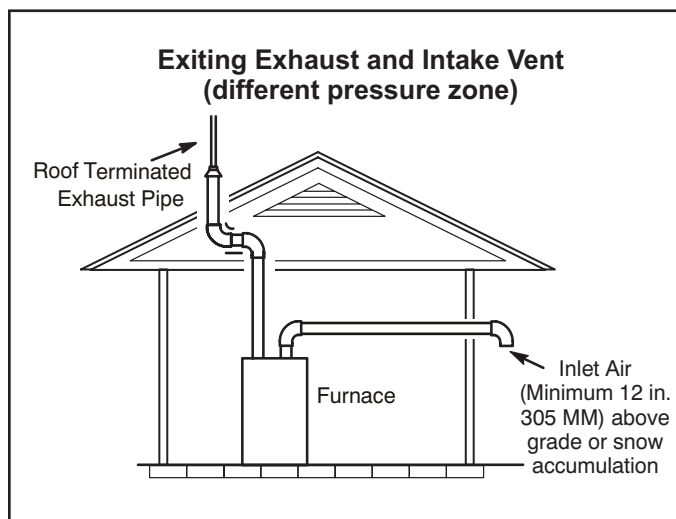

FIGURE 36

- 7 - If intake and exhaust piping must be run up a side wall to position above snow accumulation or other obstructions, piping must be supported. At least one bracket must be used within 6" from the top of the elbow and then every 24" (610mm) as shown in FIGURE 42, to prevent any movement in any direction. When exhaust and intake piping must be run up an outside wall, the exhaust piping must be terminated with pipe sized per table 20. The intake piping may be equipped with a 90° elbow turndown. Using turndown will add 5 feet (1.5m) to the equivalent length of the pipe.
- 8 - A multiple furnace installation may use a group of up to four terminations assembled together horizontally, as shown in FIGURE 39.

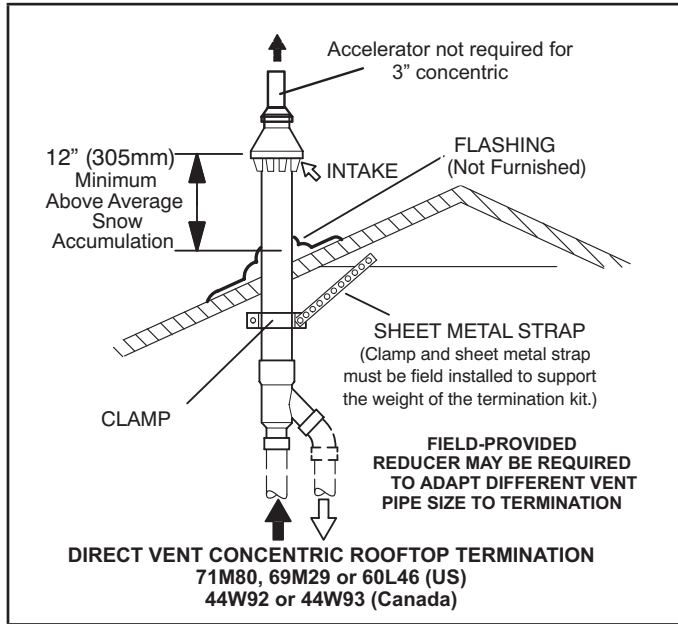

FIGURE 37

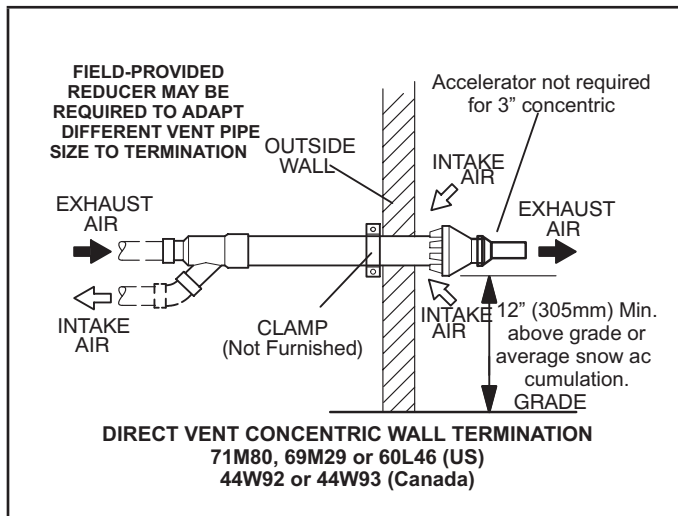

FIGURE 38

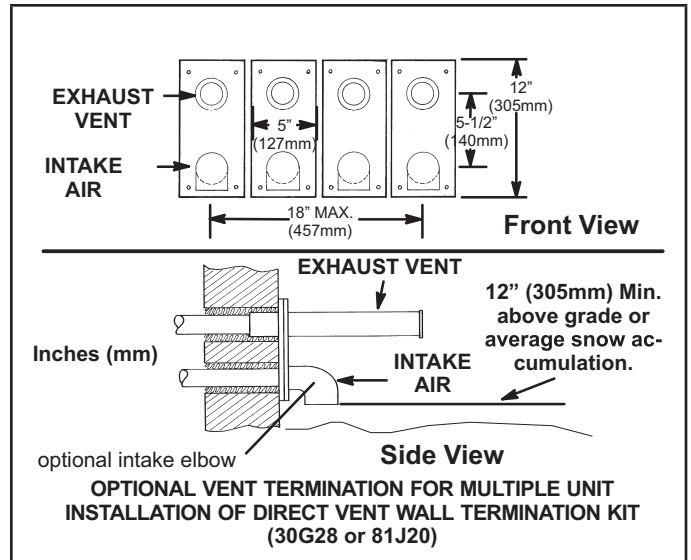

FIGURE 39

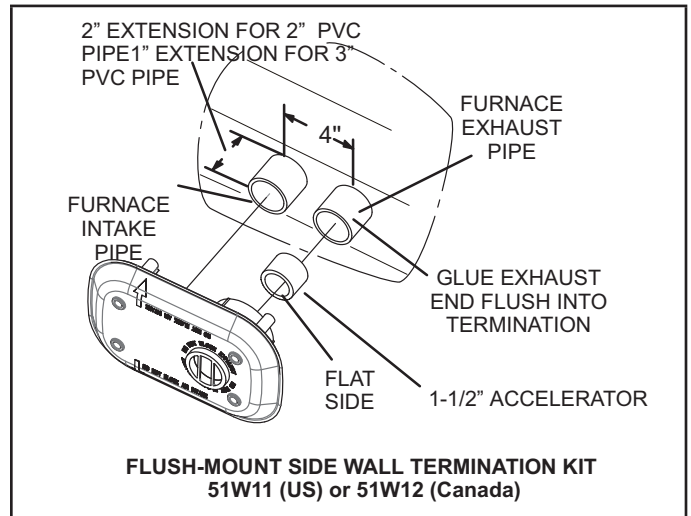

FIGURE 40

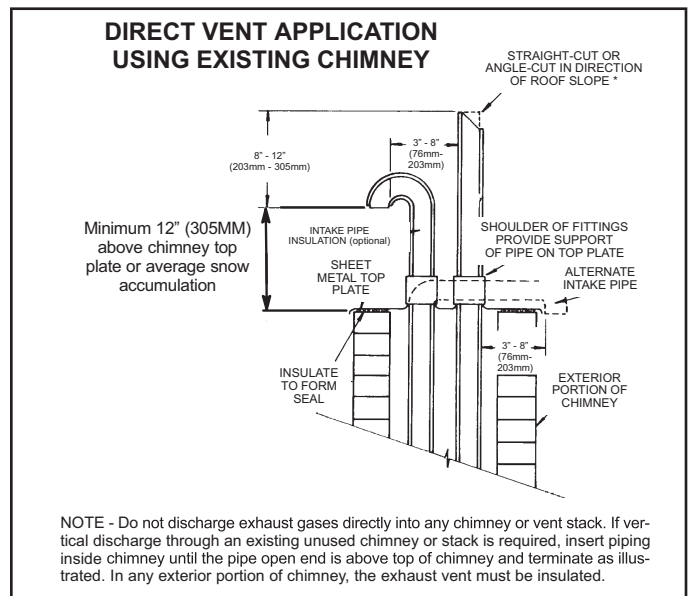
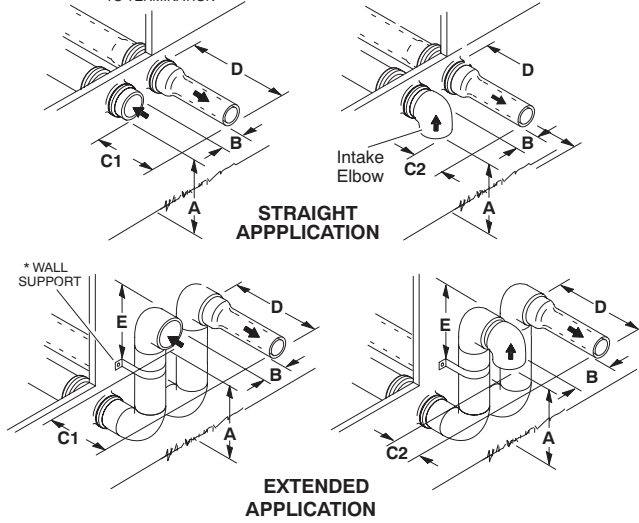

FIGURE 41

NOTE - FIELD-PROVIDED REDUCER MAY BE REQUIRED TO ADAPT LARGER VENT PIPE SIZE TO TERMINATION

FIELD FABRICATED WALL TERMINATION



	2" (51mm) Vent Pipe	3" (76mm) Vent Pipe
A - Minimum clearance above grade or average snow accumulation	12" (305 mm)	12" (305 mm)
B - Maximum horizontal separation between intake and exhaust	6" (152 mm)	6" (152 mm)
C1 - Minimum from end of exhaust to inlet of intake	8" (203 mm)	8" (203 mm)
C2 - Minimum from end of exhaust to inlet of intake	6" (152 mm)	6" (152 mm)
D - Maximum exhaust pipe length	12" (305 mm)	20" (508 mm)
E - Maximum wall support distance from top of each pipe (intake/exhaust)	6" (152 mm)	6" (152 mm)

See maximum allowable venting tables for venting lengths with this arrangement.

* Use wall support every 24" (610 mm). Use two wall supports if extension is greater than 24" (610 mm) but less than 48" (1219 mm).

NOTE - One wall support must be within 6" (152 mm) from top of each pipe (intake and exhaust) to prevent movement in any direction.

ALTERNATE TERMINATIONS (TEE & FORTY-FIVE DEGREE ELBOWS ONLY)

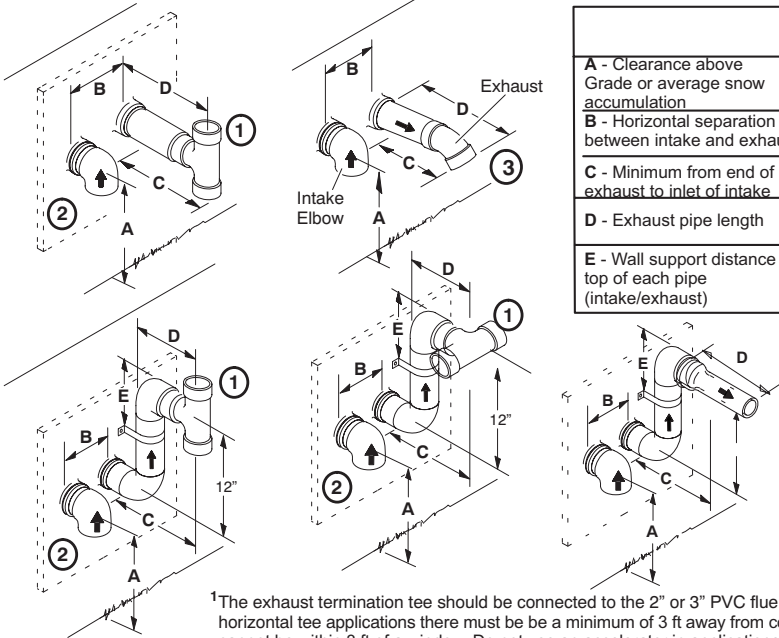

	2" (51mm) Vent Pipe	3" (76mm) Vent Pipe
A - Clearance above Grade or average snow accumulation	12" (305 mm) Min	12" (305 mm) Min
B - Horizontal separation between intake and exhaust	6" (152mm)min 24" (610mm)Max	6" (152mm)min 24" (610mm)Max
C - Minimum from end of exhaust to inlet of intake	9" (227mm)	9" (227mm)
D - Exhaust pipe length	12" (305mm)min 16" (405mm)Max	12" (305mm)min 16" (405mm)Max
E - Wall support distance from top of each pipe (intake/exhaust)	6" (152mm) Max	6" (152mm) Max

- 1 The exhaust termination tee should be connected to the 2" or 3" PVC flue pipe as shown in the illustration. In horizontal tee applications there must be a minimum of 3 ft away from covered patios or any living areas and cannot be within 3 ft of a window. Do not use an accelerator in applications that include an exhaust termination tee. The accelerator is not required.
- 2 As required. Flue gas may be acidic and may adversely affect some building materials. If a side wall vent termination is used and flue gases will impinge on the building materials, a corrosion-resistant shield (24 inches square) should be used to protect the wall surface. If optional tee is used, the protective shield is recommended. The shield should be constructed using wood, sheet metal or other suitable material. All seams, joints, cracks, etc. in affected area, should be sealed using an appropriate sealant.
- 3 Exhaust pipe 45° elbow can be rotated to the side away from the combustion air inlet to direct exhaust away from adjacent property. The exhaust must never be directed toward the combustion air inlet.

FIGURE 42

Details of Exhaust Piping Terminations for Non-Direct Vent Applications

Exhaust pipes may be routed either horizontally through an outside wall or vertically through the roof. In attic or closet installations, vertical termination through the roof is preferred. FIGURE 43 and FIGURE 44 shows typical terminations.

- 1 - Exhaust piping must terminate straight out or up as shown. The termination pipe must be sized as listed in TABLE 20. The specified pipe size ensures proper velocity required to move the exhaust gases away from the building.
- 2 - On field supplied terminations for side wall exit, exhaust piping may extend a maximum of 12 inches (305mm) for 2" PVC and 20 inches (508mm) for 3" (76mm) PVC beyond the outside wall.
- 3 - If exhaust piping must be run up a side wall to position above snow accumulation or other obstructions, piping must be supported every 24 inches (610mm). When exhaust piping must be run up an outside wall, any reduction in exhaust pipe size must be done after the final elbow.
- 4 - Distance between exhaust pipe terminations on multiple furnaces must meet local codes.

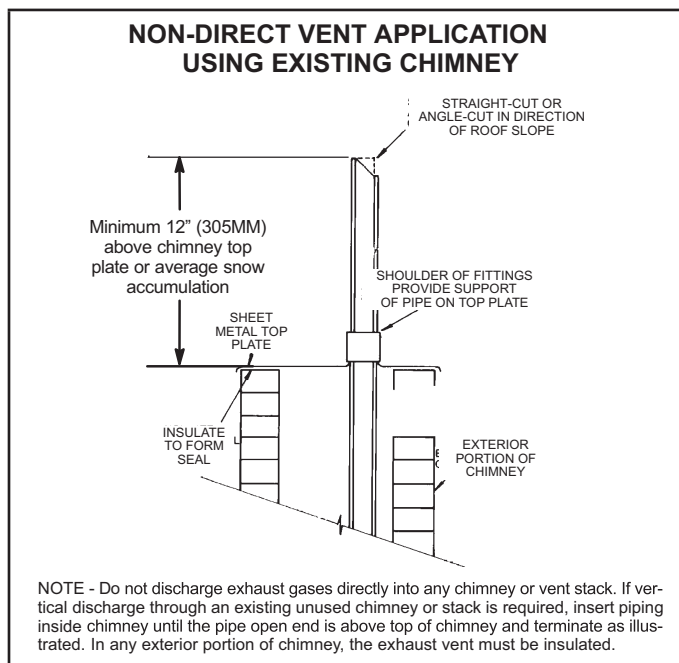

FIGURE 43

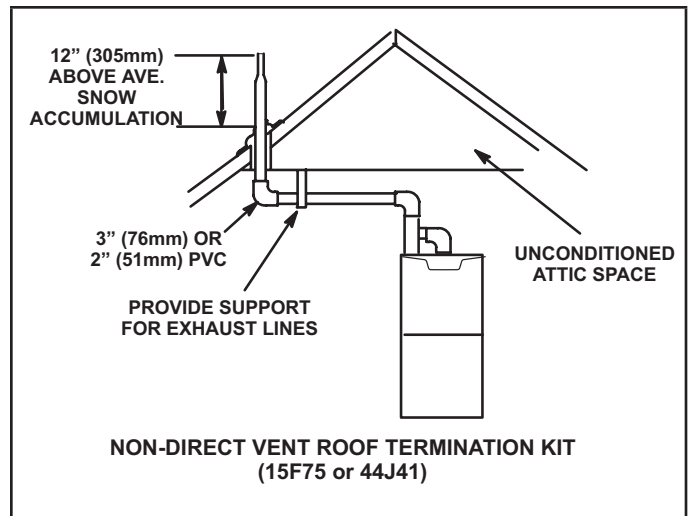

FIGURE 44

Condensate Piping

This unit is designed for either right-or left-side exit of condensate piping. Refer to FIGURE 45 and FIGURE 47 for condensate trap locations.

NOTE - If necessary the condensate trap may be installed up to 5' away from the furnace. Use PVC pipe to connect trap to furnace condensate outlet. Piping from furnace must slope down a minimum of 1/4" per ft. toward trap.

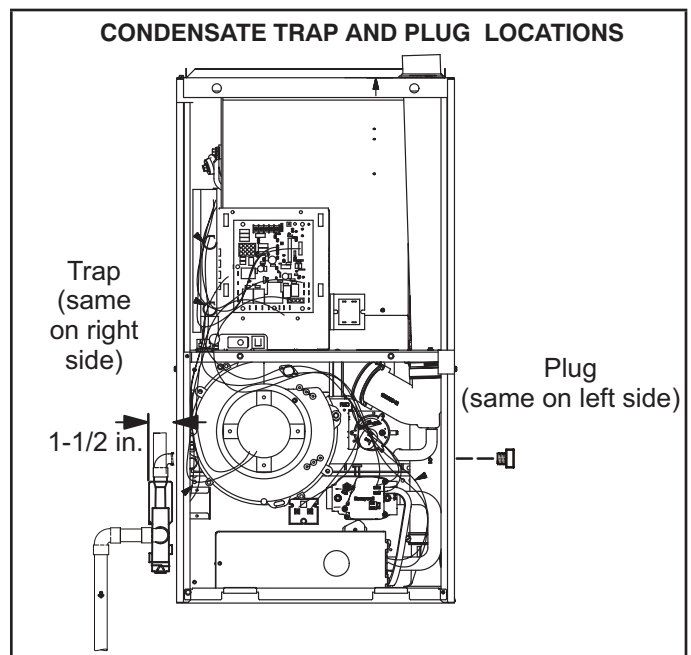

FIGURE 45

- 1 - Determine which side condensate piping will exit the unit, location of trap, field-provided fittings and length of PVC pipe required to reach available drain.
- 2 - For furnaces with a 1/2" drain connection use a 3/8 allen wrench and remove plug (FIGURE 45) from the cold end header box at the appropriate location on the side of the unit. Install field-provided 1/2 NPT male fitting into cold end header box. For furnaces with a 3/4" drain connection use a large flat head screw driver or a 1/2" drive socket extension and remove plug. Install provided 3/4 NPT street elbow fitting into cold end header box. Use Teflon tape or appropriate pipe dope.
- 3 - Install the cap over the clean out opening at the base of the trap. Secure with clamp. See FIGURE 51 (3/4" drain connection) or FIGURE 52 (1/2" drain connection).
- 4 - Install drain trap using appropriate PVC fittings, glue all joints. Glue the provided drain trap as shown in FIGURE 51 or FIGURE 52. Route the condensate line to an open drain.
- 5 - FIGURE 49 shows the furnace and evaporator coil using a separate drain. If necessary, the condensate line from the furnace and evaporator coil can drain together. See FIGURE 50. The field provided vent must be a minimum 1" to a maximum 2" length above the condensate drain outlet connection.

NOTE - If necessary the condensate trap may be installed up to 5 feet away from the furnace. Piping from furnace must slope down a minimum of 1/4" per ft. toward trap.

NOTE - Appropriately sized tubing and barbed fitting may be used for condensate drain. Attach to the drain on the trap using a hose clamp. See FIGURE 46.

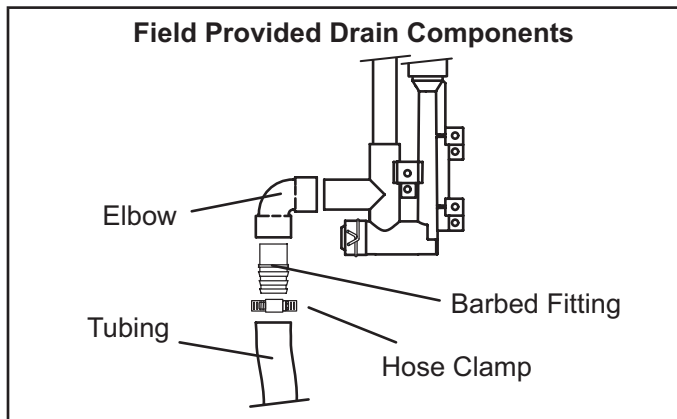

FIGURE 46

- 6 - If unit will be started immediately upon completion of installation, prime trap per procedure outlined in Unit Start-Up section. Condensate line must slope downward away from the trap to drain. If drain level is above condensate trap, condensate pump must be used. Condensate drain line should be routed within the conditioned space to avoid freezing of condensate and blockage of drain line. If this is not possible, a heat cable kit may be used on the condensate trap and line. Heat cable kit is available from Lennox in various lengths; 6 ft. (1.8m) - kit no. 26K68; 24 ft. (7.3m) - kit no. 26K69; and 50 ft. (15.2m) - kit no. 26K70.

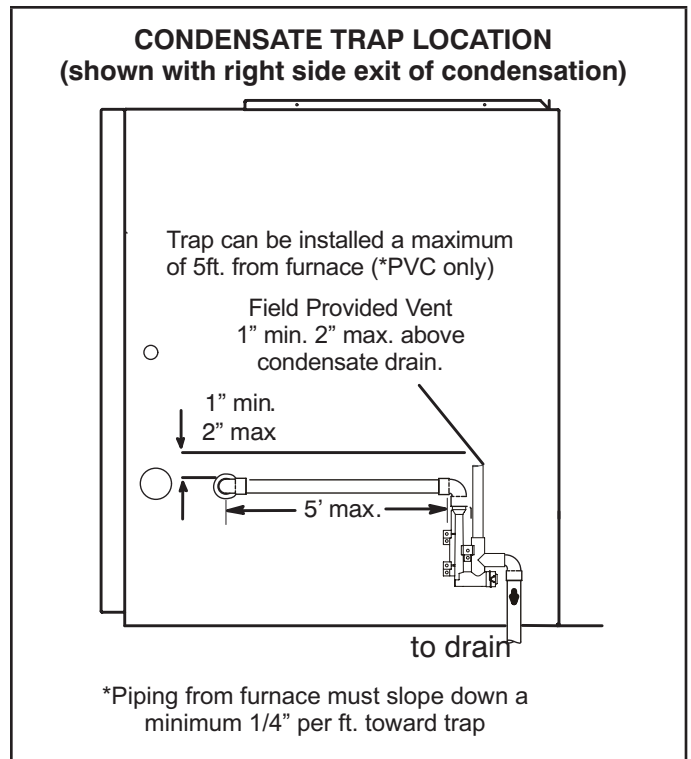

FIGURE 47

! CAUTION
Do not use copper tubing or existing copper condensate lines for drain line.

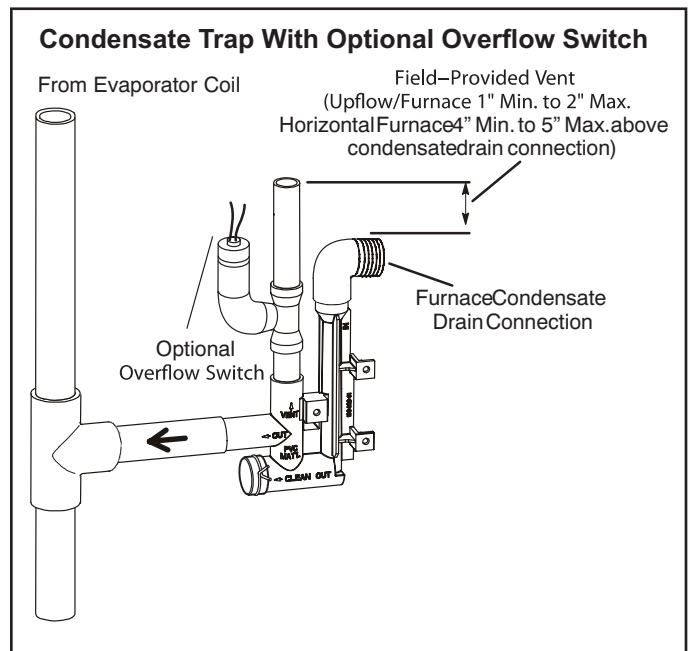

FIGURE 48

**Furnace with Evaporator Coil
Using a Separate Drain**

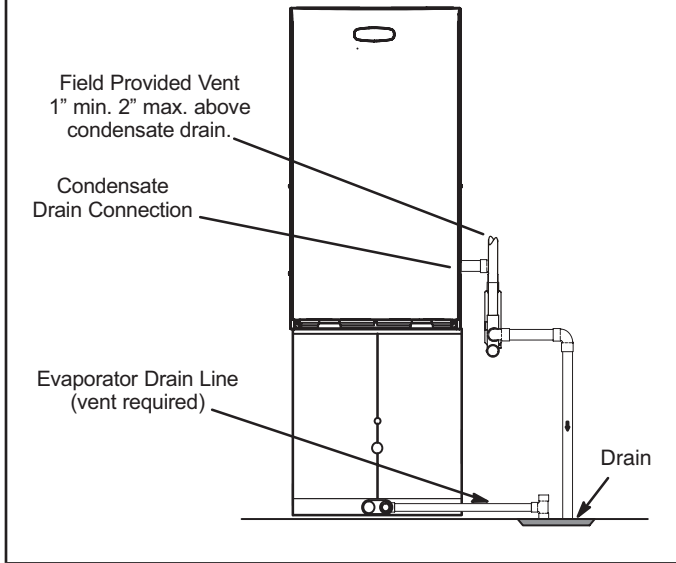

FIGURE 49

**Furnace with Evaporator
Coil Using a Common Drain**

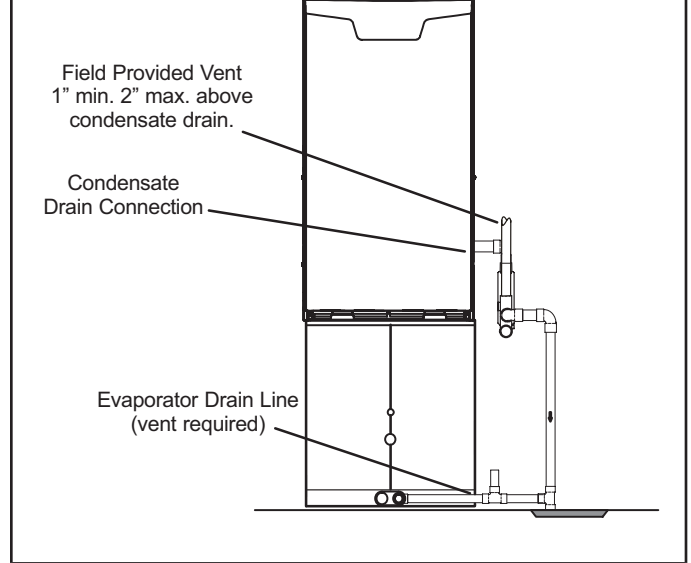

FIGURE 50

⚠ IMPORTANT

When combining the furnace and evaporator coil drains together, the A/C condensate drain outlet must be vented to relieve pressure in order for the furnace pressure switch to operate properly.

**TRAP / DRAIN ASSEMBLY USING 1/2" PVC OR 3/4" PVC
COLD END HEADER BOX WITH 3/4" DRAIN CONNECTION**

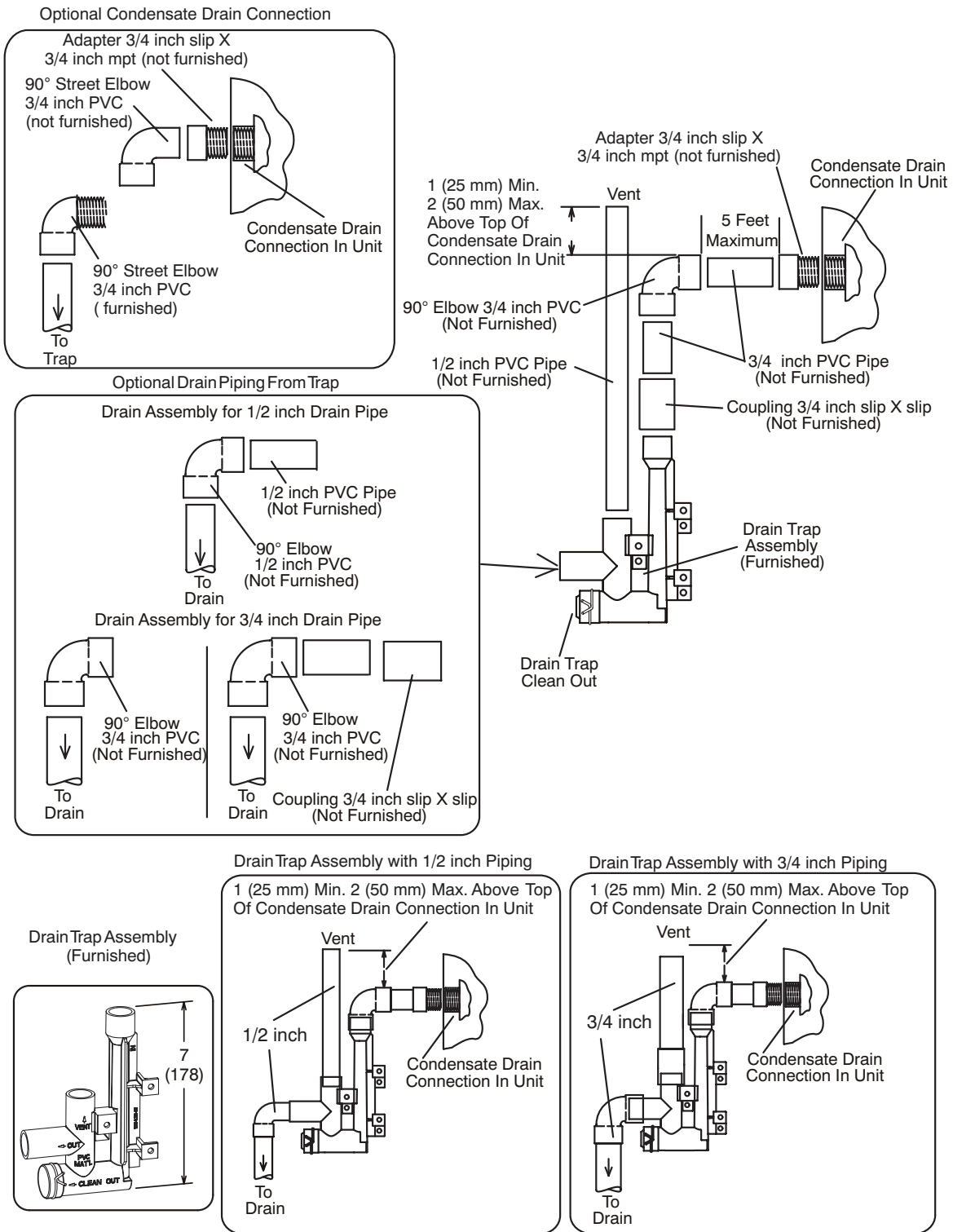
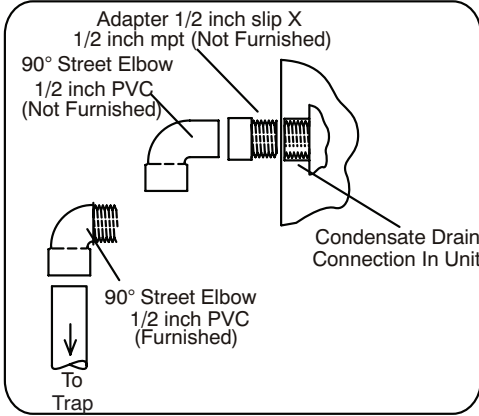

FIGURE 51

**TRAP / DRAIN ASSEMBLY USING 1/2" PVC OR 3/4" PVC
COLD END HEADER BOX WITH 1/2" DRAIN CONNECTION**

Optional Condensate Drain Connection



Optional Drain Piping From Trap

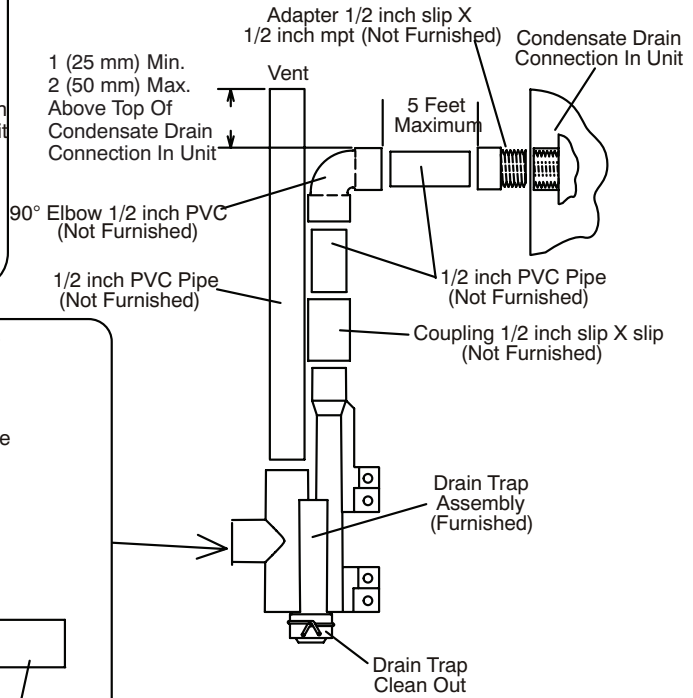
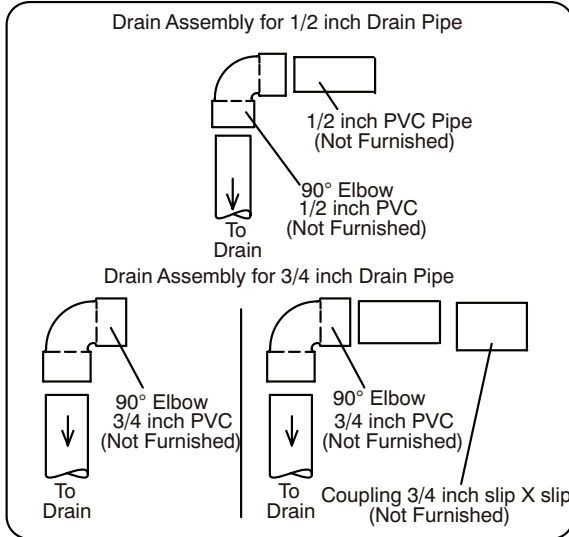

Drain Trap Assembly with 3/4 inch Piping

Drain Trap Assembly with 1/2 inch Piping

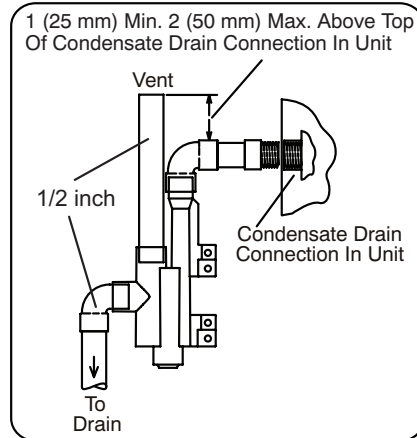

Drain Trap Assembly with 3/4 inch Piping

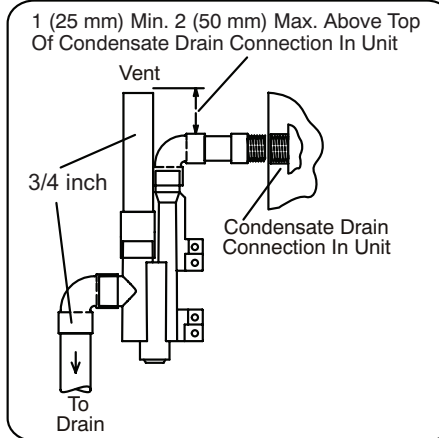

Drain Trap Assembly (Furnished)

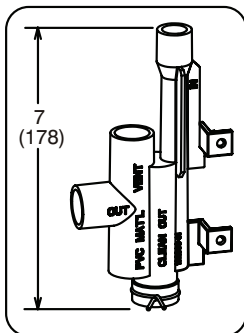

FIGURE 52

III-START-UP

A-Preliminary and Seasonal Checks

- 1 - Inspect electrical wiring, both field and factory installed for loose connections. Tighten as required.
- 2 - Check voltage at disconnect switch. Voltage must be within range listed on the nameplate. If not, consult the power company and have voltage condition corrected before starting unit.
- 3 - Inspect condition of condensate traps and drain assembly. Disassemble and clean seasonally.

B-Heating Start-Up

BEFORE LIGHTING the unit, smell all around the furnace area for gas. Be sure to smell next to the floor because some gas is heavier than air and will settle on the floor. The gas valve on the EL296DFE is equipped with a gas control switch. Use only your hand to move the switch. Never use tools. If the the switch will not move by hand, replace the valve. Do not try to repair it. Force or attempted repair may result in a fire or explosion.

Placing the furnace into operation:

EL296DFE units are equipped with a SureLight® ignition system. Do not attempt to manually light burners on this furnace. Each time the thermostat calls for heat, the burners will automatically light. The ignitor does not get hot when there is no call for heat on units with SureLight ignition system.

Priming Condensate Trap

The condensate trap should be primed with water prior to start-up to ensure proper condensate drainage. Either pour 10 fl. oz. (300 ml) of water into the trap, or follow these steps to prime the trap:

- 1 - Follow the lighting instructions to place the unit into operation.
- 2 - Set the thermostat to initiate a heating demand.
- 3 - Allow the burners to fire for approximately 3 minutes.
- 4 - Adjust the thermostat to deactivate the heating demand.
- 5 - Wait for the combustion air inducer to stop. Set the thermostat to initiate a heating demand and again allow the burners to fire for approximately 3 minutes.
- 6 - Adjust the thermostat to deactivate the heating demand and again wait for the combustion air inducer to stop. At this point, the trap should be primed with sufficient water to ensure proper condensate drain operation.

⚠ WARNING

If you do not follow these instructions exactly, a fire or explosion may result causing property damage, personal injury or death.

Gas Valve Operation (FIGURE 53)

- 1 - **STOP!** Read the safety information at the beginning of this section.
- 2 - Set the thermostat to the lowest setting.

- 3 - Turn off all electrical power to the unit.
- 4 - This furnace is equipped with an ignition device which automatically lights the burners. Do **not** try to light the burners by hand.
- 5 - Remove the upper access panel.
- 6 - Move gas valve switch to **OFF**. See FIGURE 53.
- 7 - Wait five minutes to clear out any gas. If you then smell gas, **STOP!** Immediately call your gas supplier from a neighbor's phone. Follow the gas supplier's instructions. If you do not smell gas go to next step.
- 8 - Move gas valve switch to **ON**. See FIGURE 53.

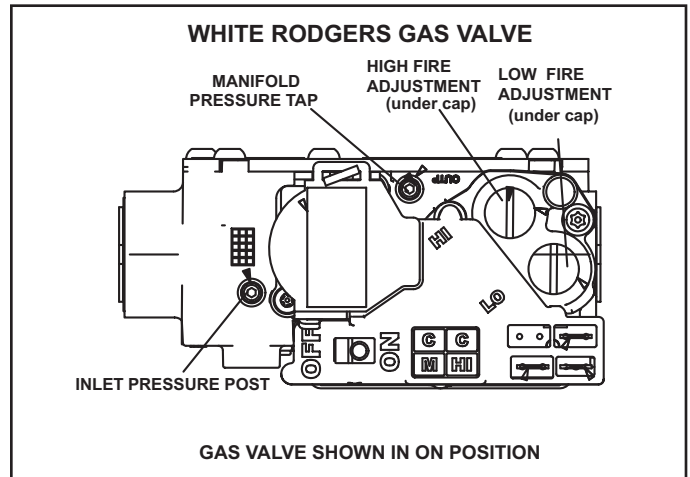

FIGURE 53

- 9 - Replace the upper access panel.
 - 10 - Turn on all electrical power to to the unit.
 - 11 - Set the thermostat to desired setting.
- NOTE** - When unit is initially started, steps 1 through 11 may need to be repeated to purge air from gas line.
- 12 - If the appliance will not operate, follow the instructions "Turning Off Gas to Unit" and call your service technician or gas supplier.

Turning Off Gas to Unit

- 1 - Set the thermostat to the lowest setting.
- 2 - Turn off all electrical power to the unit if service is to be performed.
- 3 - Remove the upper access panel.
- 4 - Move gas valve switch to OFF.
- 5 - Replace the upper access panel.

Failure To Operate

If the unit fails to operate, check the following:

- 1 - Is the thermostat calling for heat?
- 2 - Are access panels securely in place?
- 3 - Is the main disconnect switch closed?
- 4 - Is there a blown fuse or tripped breaker?
- 5 - Is the filter dirty or plugged? Dirty or plugged filters will cause the limit control to shut the unit off.
- 6 - Is gas turned on at the meter?
- 7 - Is the manual main shut-off valve open?
- 8 - Is the internal manual shut-off valve open?
- 9 - Is the unit ignition system in lockout? If the unit locks out again, inspect the unit for blockages.

IV-HEATING SYSTEM SERVICE CHECKS

A-CSA Certification

All units are CSA design certified without modifications. Refer to the EL296DFE Installation Instruction.

B-Gas Piping

⚠ CAUTION

If a flexible gas connector is required or allowed by the authority that has jurisdiction, black iron pipe shall be installed at the gas valve and extend outside the furnace cabinet. The flexible connector can then be added between the black iron pipe and the gas supply line.

⚠ WARNING

Do not over torque (800 in-lbs) or under torque (350 in-lbs) when attaching the gas piping to the gas valve.

Gas supply piping should not allow more than 0.5"W.C. drop in pressure between gas meter and unit. Supply gas pipe must not be smaller than unit gas connection.

Compounds used on gas piping threaded joints should be resistant to action of liquefied petroleum gases.

C-Testing Gas Piping

⚠ IMPORTANT

In case emergency shutdown is required, turn off the main shut-off valve and disconnect the main power to unit. These controls should be properly labeled by the installer.

When pressure testing gas lines, the gas valve must be disconnected and isolated. Gas valves can be damaged if subjected to more than 0.5 psig (14" W.C.). See FIGURE 54. If the pressure is greater than 0.5psig (14"W.C.), use the manual shut-off valve before pressure testing to isolate furnace from gas supply.

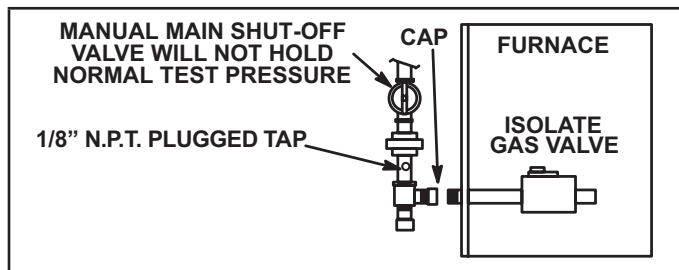

FIGURE 54

When checking piping connections for gas leaks, use preferred means. Kitchen detergents can cause harmful corrosion on various metals used in gas piping. Use of a specialty Gas Leak Detector is strongly recommended. It is available through Lennox under part number 31B2001. See Corp. 8411-L10, for further details.

Do not use matches, candles, flame or any other source of ignition to check for gas leaks.

D-Testing Gas Supply Pressure

An inlet pressure post located on the gas valve provides access to the supply pressure. See FIGURE 53. Back out the 3/32 hex screw one turn, connect a piece of 5/16 tubing and connect to a manometer to measure supply pressure. See TABLE 24 for supply line pressure.

E-Check Manifold Pressure

NOTE - Pressure test adapter kit (10L34) is available from Lennox to facilitate manifold pressure measurement.

A manifold pressure post located on the gas valve provides access to the manifold pressure. See FIGURE 53. Back out the 3/32 hex screw one turn, connect a piece of 5/16 tubing and connect to a manometer to measure manifold pressure.

To correctly measure manifold pressure, the differential pressure between the positive gas manifold and the negative burner box must be considered.

⚠ IMPORTANT

For safety, connect a shut-off valve between the manometer and the gas tap to permit shut off of gas pressure to the manometer.

- 1 - Connect the test gauge positive side "+" to manifold pressure tap on gas valve as noted above.
- 2 - Tee into the gas valve regulator vent hose and connect to test gauge negative "-".
- 3 - Ignite unit on low fire and let run for 5 minutes to allow for steady state conditions.
- 4 - After allowing unit to stabilize for 5 minutes, record low fire manifold pressure and compare to value given in TABLE 24. If necessary, make adjustment. FIGURE 53 shows location of low fire adjustment screw.
- 5 - Repeat on high fire and compare to value given in TABLE 24. If necessary, make adjustment. FIGURE 53 shows location of high fire adjustment screw.
- 6 - Shut unit off and remove manometer as soon as an accurate reading has been obtained. Take care to replace pressure tap plug.
- 7 - Start unit and perform leak check. Seal leaks if found.

The gas valve is factory set and should not require adjustment. All gas valves are factory regulated.

F- Proper Gas Flow (Approximate)

Furnace should operate at least 5 minutes before checking gas flow. Determine time in seconds for two revolutions of gas through the meter. (Two revolutions assures a more accurate time.) Divide by two and compare to time in TABLE 21. If manifold pressure matches TABLE 24 and rate is incorrect, check gas orifices for proper size and restriction.

NOTE- To obtain accurate reading, shut off all other gas appliances connected to meter.

TABLE 21

GAS METER CLOCKING CHART				
EL296 Unit	Seconds for One Revolution			
	Natural		LP	
	1 cu ft Dial	2 cu ft Dial	1 cu ft Dial	2 cu ft Dial
-045	80	160	200	400
-070	55	110	136	272
-090	41	82	102	204
-110	33	66	82	164
Natural-1000 btu/cu ft LP-2500 btu/cu ft				

⚠ IMPORTANT

For safety, connect a shut-off valve between the manometer and the gas tap to permit shut off of gas pressure to the manometer.

G- Proper Combustion

Furnace should operate minimum 15 minutes with correct manifold pressure and gas flow rate before checking combustion. See sections E- and F-. Take combustion sample beyond the flue outlet. TABLE 22 shows acceptable combustions. The maximum carbon monoxide reading should not exceed 100 ppm.

TABLE 22

EL296 Model	CO ₂ % For Nat		CO ₂ % For L.P	
	Low Fire	High Fire	Low Fire	High Fire
045	5.6 - 6.6	7.8 - 8.8	6.6 - 7.6	9.1 - 10.1
070	5.5 - 6.5	7.3 - 8.3	6.5 - 7.5	8.6 - 9.6
090	5.9 - 6.9	7.8 - 8.8	6.9 - 7.9	9.1 - 10.1
110	6.3 - 7.3	8.2 - 9.2	7.3 - 8.3	9.5 - 10.5
The maximum carbon monoxide reading should not exceed 100ppm.				

H- High Altitude

The manifold pressure, gas orifice and pressure switch may require adjustment or replacement to ensure proper operation at higher altitudes. See TABLE 23 for gas conversion and pressure switch kits. See TABLE 24 for manifold pressures

TABLE 23

Conversion Kit and Pressure Switch Requirements at Varying Altitudes

Unit	Natural to LP/Propane	High Altitude Natural Burner Orifice Kit	High Altitude LP/Propane Burner Orifice Kit	High Altitude Pressure Switch	
	0 - 7500 ft	7501 - 10,000 ft	7501 - 10,000 ft	4501 - 7500 ft	7501 - 10,000 ft
-045	*11K51	73W37	*11K46	14A47	14A50
-070-1, -2				14A46	14A51
-070-3 & later				14A55	14A56
-090				14A54	14A53
-110				14A46	14A51

* Conversion requires installation of a gas valve manifold spring which is provided with the gas conversion kit. Pressure switch is factory set. No adjustment necessary. All models use the factory-installed pressure switch from 0-4500 feet (0-1370 m).

TABLE 24

Conversion Kit and Pressure Switch Requirements at Varying Altitudes

Unit	Natural to LP/Propane	High Altitude Natural Burner Orifice Kit	High Altitude LP/Propane Burner Orifice Kit	High Altitude Pressure Switch	
	0 - 7500 ft	7501 - 10,000 ft	7501 - 10,000 ft	4501 - 7500 ft	7501 - 10,000 ft
-045	*11K51	73W37	*11K46	14A47	14A50
-070-1, -2				14A46	14A51
-070-3 & later				14A55	14A56
-090				14A54	14A53
-110				14A46	14A51

* Conversion requires installation of a gas valve manifold spring which is provided with the gas conversion kit. Pressure switch is factory set. No adjustment necessary. All models use the factory-installed pressure switch from 0-4500 feet (0-1370 m).

I- Proper Ground and Voltage

Furnace must be properly grounded for proper performance. Use the following procedure to check for ground and voltage to the integrated control.

- 1 - Measure the AC voltage between Line Neutral (spade terminals) and "C" terminal (low voltage terminal block) on the integrated control. See FIGURE 55. A wide variation in the voltage between Line Neutral and "C" as a function of load indicates a poor or partial ground. Compare the readings to the table below. If the readings exceed the maximum shown in TABLE 25, make repairs before operating the furnace

- 2 - In addition, measure the AC voltage from Line Hot to Line Neutral (spade terminals) on the integrated control. See FIGURE 55. This voltage should be in the range of 97 to 132 Vac.

TABLE 25

Furnace Status	Measurement VAC	
	Expected	Maximum
Power On Furnace Idle	0.3	2
CAI / Ignitor Energized	0.75	5
Indoor Blower Energized	Less than 2	10

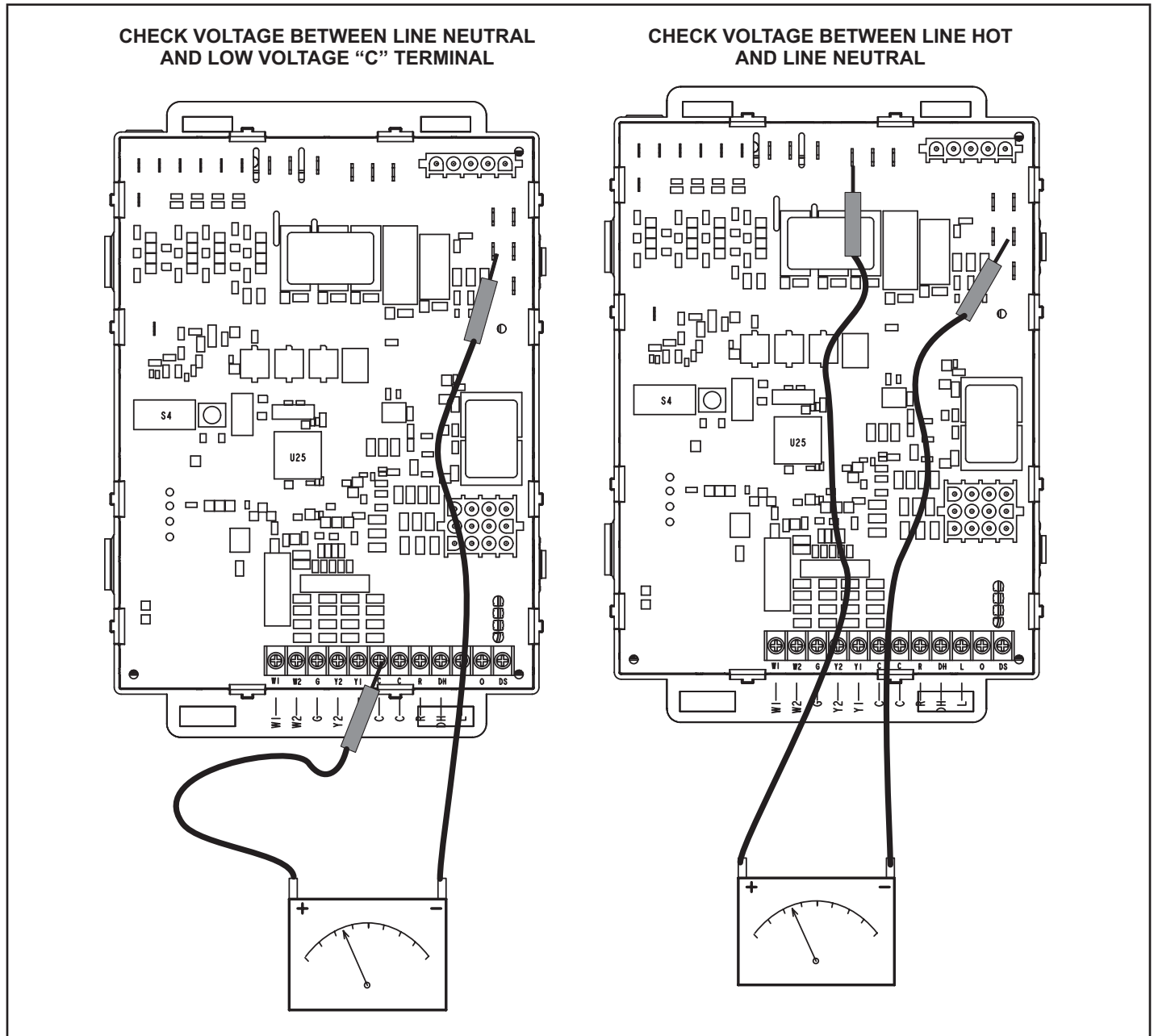

FIGURE 55

V-TYPICAL OPERATING CHARACTERISTICS

A-Blower Operation and Adjustment

- 1 - Blower operation is dependent on thermostat control system.
- 2 - Generally, blower operation is set at thermostat subbase fan switch. With fan switch in ON position, blower operates continuously. With fan switch in AUTO position, blower cycles with demand or runs continuously while heating or cooling circuit cycles.
- 3 - Depending on the type of indoor thermostat, blower and entire unit will be off when the system switch is in OFF position.

B-Temperature Rise (FIGURE 56)

Temperature rise for EL296UHE units depends on unit input, blower speed, blower horsepower and static pressure as marked on the unit rating plate. The blower speed must be set for unit operation within the range of "TEMP. RISE °F" listed on the unit rating plate.

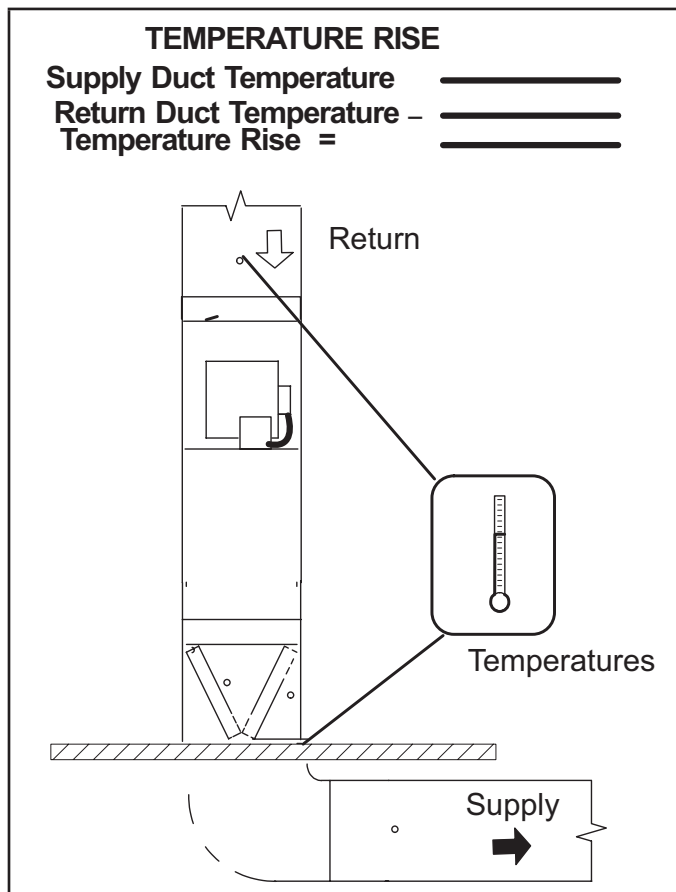

FIGURE 56

C-External Static Pressure

- 1 - Tap locations shown in FIGURE 57.
- 2 - Punch a 1/4" diameter hole in supply and return air plenums. Insert manometer hose flush with inside edge of hole or insulation. Seal around the hose with permagum. Connect the zero end of the manometer to the discharge (supply) side of the system. On ducted systems, connect the other end of manometer to the return duct as above.
- 3 - With only the blower motor running and the evaporator coil dry, observe the manometer reading. Adjust blower motor speed to deliver the air desired according to the job requirements. For heating speed (second stage heat speed) external static pressure drop must not be more than 0.5" W.C. For cooling speed (second stage cool speed) external static pressure drop must not be more than 0.5" W.C.
- 4 - Seal the hole when the check is complete.

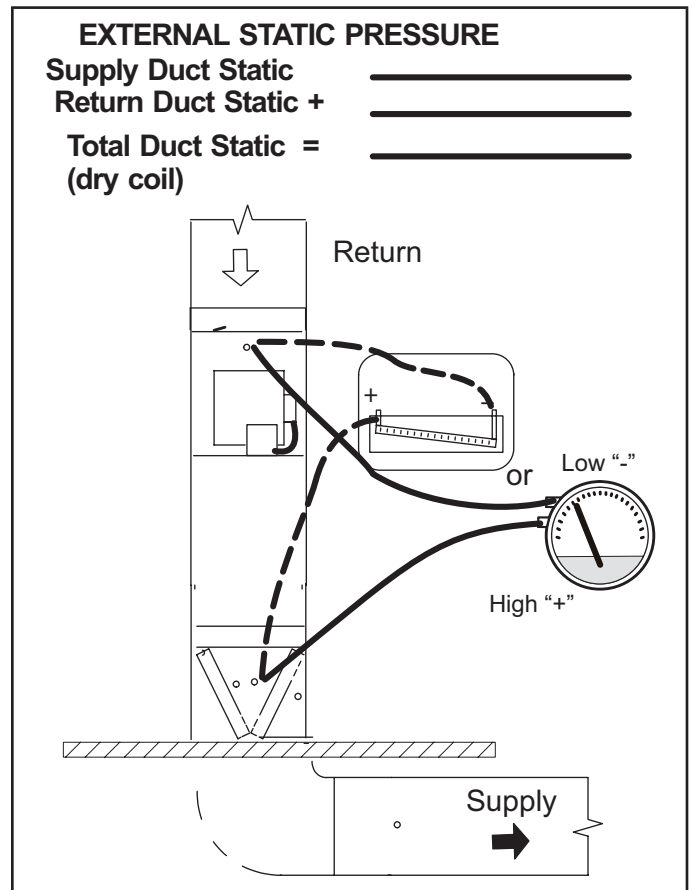

FIGURE 57

TABLE 26

⚠ WARNING
ELECTRICAL SHOCK, FIRE, OR EXPLOSION HAZARD.
 Failure to follow safety warnings exactly could result in dangerous operation, serious injury, death or property damage.
 Improper servicing could result in dangerous operation, serious injury, death, or property damage. Before servicing, disconnect all electrical power to furnace.
 When servicing controls, label all wires prior to disconnecting. Take care to reconnect wires correctly. Verify proper operation after servicing.

At the beginning of each heating season, system should be checked as follows by a qualified service technician:

Blower

Check the blower wheel for debris and clean if necessary. The blower motors are prelubricated for extended bearing life. No further lubrication is needed.

⚠ WARNING
 The blower access panel must be securely in place when the blower and burners are operating. Gas fumes, which could contain carbon monoxide, can be drawn into living space resulting in personal injury or death.

Filters

All air filters are installed external to the unit. Filters should be inspected monthly. Clean or replace the filters when necessary to ensure proper furnace operation. TABLE 26 lists recommended filter sizes.

⚠ IMPORTANT
 If a highefficiency filter is being installed as part of this system to ensure better indoor air quality, the filter must be properly sized. Highefficiency filters have a higher static pressure drop than standardefficiency glass/foam filters. If the pressure drop is too great, system capacity and performance may be reduced. The pressure drop may also cause the limit to trip more frequently during the winter and the indoor coil to freeze in the summer, resulting in an increase in the number of service calls.
 Before using any filter with this system, check the specifications provided by the filter manufacturer against the data given in the appropriate Lennox Product Specifications bulletin. Additional information is provided in Service and Application Note ACC002 (August 2000).

Cabinet Width	Filter Size
17-1/2"	16 x 25 x 1(1)
21"	

Exhaust and air intake pipes

Check the exhaust and air intake pipes and all connections for tightness and to make sure there is no blockage.

NOTE - After any heavy snow, ice or frozen fog event the furnace vent pipes may become restricted. Always check the vent system and remove any snow or ice that may be obstructing the plastic intake or exhaust pipes.

Electrical

⚠ CAUTION
 Failure to use properly sized wiring and circuit breaker may result in property damage. Size wiring and circuit breaker(s) per Product Specifications bulletin (EHB) and unit rating plate.

- 1 - Check all wiring for loose connections.
- 2 - Check for the correct voltage at the furnace (furnace operating).
- 3 - Check amp-draw on the blower motor.
 Motor Nameplate _____ Actual _____

Winterizing and Condensate Trap Care

- 1 - 1 - Turn off power to the furnace.
- 2 - Have a shallow pan ready to empty condensate water.
- 3 - Remove the clean out cap from the condensate trap and empty water. Inspect the trap then reinstall the clean out cap.

Condensate Hose Screens (FIGURE 58)

Check the condensate hose screens for blockage and clean if necessary.

- 1 - Turn off power to the unit.
- 2 - Remove hoses from cold end header box. Twist and pull screens to remove.
- 3 - Inspect screens and rinse with tap water if needed.
- 4 - Reinstall screens, reconnect hoses and turn on power to unit.

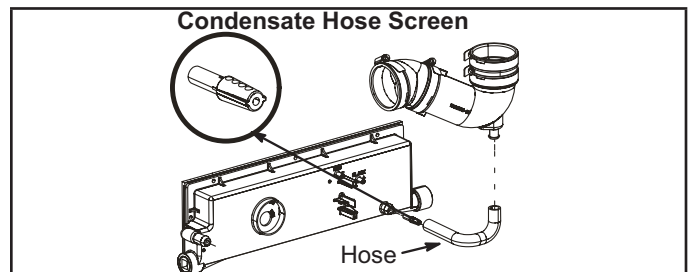

FIGURE 58

Cleaning Heat Exchanger

If cleaning the heat exchanger becomes necessary, follow the below procedures and refer to FIGURE 1 when disassembling unit. Use papers or protective covering in front of furnace while removing heat exchanger assembly.

- 1 - Turn off electrical and gas supplies to the furnace.
- 2 - Remove the furnace access panels.
- 3 - Disconnect the wires from the gas valve.
- 4 - Remove gas supply line connected to gas valve. Remove the burner box cover (if equipped) and remove gas valve/manifold assembly.
- 5 - Remove sensor wire from sensor. Disconnect 2-pinplug from the ignitor.
- 6 - Disconnect wires from flame roll-out switches.
- 7 - Loosen clamps at vent elbow. Disconnect condensate drain tubing from flue collar. and remove the vent elbow.
- 8 - Loosen clamps and remove combustion air intake flexible connector if equipped.
- 9 - Remove four burner box screws at the vestibule panel and remove burner box. Set burner box assembly aside.

NOTE - *If necessary, clean burners at this time. Follow procedures outlined in Burner Cleaning section.*

- 10 - Mark and disconnect all combustion air pressure tubing from cold end header collector box.
- 11 - Mark and remove wires from pressure switch assembly. Remove pressure switch assembly. Keep tubing attached to pressure switch assembly.
- 12 - 12 - Disconnect the plug from the combustion air inducer. Remove two screws which secure combustion air inducer to collector box. Remove combustion air inducer assembly. Remove ground wire from vest panel.
- 13 - Remove electrical junction box from the side of the furnace.
- 14 - Disconnect condensate line from cold end header box. Remove cold end header box.
- 15 - Loosen clamps on exhaust and air intake pipe seal plate. Slide exhaust and intake pipes up and out to clear blower deck. Remove exhaust and air intake pipe seal plate.
- 16 - Mark and disconnect any remaining wiring to heating compartment components. Disengage strain relief bushing and pull wiring and bushing through the hole in the blower deck.
- 17 - Remove the primary limit from the vestibule panel.
- 18 - Remove two screws from the front cabinet flange at the blower deck. Spread cabinet sides slightly to allow clearance for removal of heat exchanger.
- 19 - Remove screws along vestibule sides which secure vestibule panel and heat exchanger assembly to cabinet. Remove two screws from blower rail which secure top heat exchanger flange. Remove heat exchanger from furnace cabinet.

- 20 - Back wash heat exchanger with soapy water solution or steam. If steam is used it must be below 275°F (135°C) .
- 21 - Thoroughly rinse and drain the heat exchanger. Soap solutions can be corrosive. Take care to rinse entire assembly.
- 22 - Reinstall heat exchanger into cabinet making sure that the clamshells of the heat exchanger assembly are engaged properly into the support bracket on the blower deck. Remove the indoor blower to view this area through the blower opening.
- 23 - Re-secure the supporting screws along the vestibule sides and top to the cabinet.
- 24 - Reinstall cabinet screws on front flange at blower deck.
- 25 - Reinstall the primary limit on the vestibule panel.
- 26 - Route heating component wiring through hole in blower deck and reinsert strain relief bushing.
- 27 - Reinstall electrical junction box.
- 28 - Reinstall exhaust and air intake pipe seal plate. Reinstall exhaust and air intake pipes and tighten clamps on pipe seal plate.
- 29 - Reinstall the cold end header box.
- 30 - Reinstall the combustion air inducer. Reconnect the combustion air inducer to the wire harness.
- 31 - Reinstall pressure switch assembly and reconnect pressure switch wiring.
- 32 - Carefully connect combustion air pressure switch tubing from pressure switches to proper ports on cold end header collector box.
- 33 - Reinstall condensate trap.
- 34 - Secure burner box assembly to vestibule panel using four existing screws. **Make sure burners line up in enter of burner ports.**
- 35 - Reconnect exhaust piping and exhaust drain tubing.
- 36 - Reconnect flame roll-out switch wires.
- 37 - Reconnect sensor wire and reconnect 2-pin plug from ignitor.
- 38 - Reinstall gas valve manifold assembly. Reconnect gas supply line to gas valve.
- 39 - Reinstall burner box cover if equipped.
- 40 - Reconnect plug to gas valve.
- 41 - Replace the blower compartment access panel.
- 42 - Follow lighting instructions on unit nameplate to light and operate furnace for 5 minutes to ensure the furnace is operating properly.
- 43 - Check all piping connections, factory and field, for gas leaks. Use a leak detecting solution or other preferred means.
- 44 - Replace access panel.

CAUTION

Some soaps used for leak detection are corrosive to certain metals. Carefully rinse piping thoroughly after leak test has been completed. Do not use matches, candles, flame or other sources of ignition to check for gas leaks.

Cleaning the Burner Assembly (if needed)

- 1 - Turn off electrical and gas power supplies to furnace. Remove upper and lower furnace access panels.
- 2 - Disconnect the 2-pin plug from the gas valve.
- 3 - Remove the burner box cover (if equipped).
- 4 - Disconnect the gas supply line from the gas valve. Remove gas valve/manifold assembly.
- 5 - Loosen clamps and remove combustion air intake flexible connector (if equipped).
- 6 - Mark and disconnect sensor wire from the sensor. Disconnect plug from the ignitor at the burner box.
- 7 - Remove four screws which secure burner box assembly to vent panel. Remove burner box from the unit.
- 8 - Use the soft brush attachment on a vacuum cleaner to gently clean the face of the burners. Visually inspect the inside of the burners and crossovers for any blockage caused by foreign matter. Remove any blockage.
- 9 - Reinstall the burner box assembly using the existing four screws. Make sure that the burners line up in the center of the burner ports.
- 10 - Reconnect the sensor wire and reconnect the 2-pin plug to the ignitor wiring harness.
- 11 - Reinstall combustion air intake flexible connector (if equipped), secure using existing clamps.
- 12 - Reinstall the gas valve manifold assembly. Reconnect the gas supply line to the gas valve. Reinstall the burner box cover.
- 13 - Reconnect plug to gas valve.
- 14 - Replace the blower compartment access panel.
- 15 - Refer to instruction on verifying gas and electrical connections when re-establishing supplies.
- 16 - Follow lighting instructions to light and operate furnace for 5 minutes to ensure that heat exchanger is clean and dry and that furnace is operating properly.
- 17 - Replace access panel.

VII- Wiring and Sequence of Operation

Wiring Diagram With Integrated Control 103699-XX

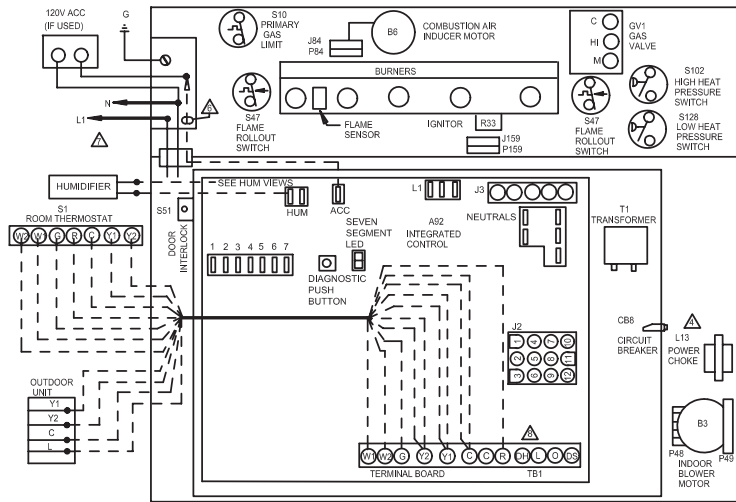

UNIT	HI COOL	LOW COOL	HIGH HEAT	LOW HEAT	PARK
DF045XE36B	BLACK	BROWN	BLUE	YELLOW	RED
DF070XE48B	BLACK	BLUE	BROWN	YELLOW	RED
DF090XE48C	BLACK	BLUE	BROWN	YELLOW	RED
DF110XE60C	BLACK	BLUE	BROWN	YELLOW	RED
BLOWER SPEED SELECTION					
HI ← → LOW					
SPEED TAPS	BLACK	BROWN	BLUE	YELLOW	RED

JACKPLUG CHART	
J.P48	JACK/PLUG-INDOOR BLOWER-POWER
J.P49	JACK/PLUG-INDOOR BLOWER-SPD TAP
J.P2	JACK/PLUG-BURNER CONTROL
J.P84	JACK/PLUG-COMB AIR INDUCER
J.P3	JACK/PLUG-INDUCER/IGNITER
J.P159	JACK/PLUG-IGNITION

NOTE: SEE INSTALLATION INSTRUCTIONS FOR PROCEDURE TO SET CORRECT BLOWER SPEED FOR SPECIFIC COOLING TONNAGE BEING APPLIED, AND HEATING TEMPERATURE RISE REQUIRED.

TYPICAL SYSTEM SHOWN FOR 2 HEAT/2 COOL WITH A CONVENTIONAL THERMOSTAT. SEE INSTALLATION INSTRUCTIONS FOR CONNECTIONS TO OTHER EQUIPMENT AND ACCESSORIES.

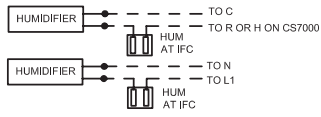

THERMOSTAT HEAT ANTICIPATION SETTING	
65 AMP	HONEYWELL VALVE
43 AMP	WHITE RODGERS VALVE

WARNING- ELECTRIC SHOCK HAZARD, CAN CAUSE INJURY OR DEATH. UNIT MUST BE GROUNDED IN ACCORDANCE WITH NATIONAL AND LOCAL CODES.

NOTE: IF ANY WIRE IN THIS APPLIANCE IS REPLACED IT MUST BE REPLACED WITH WIRE OF LIKE SIZE, RATING, INSULATION THICKNESS, AND TERMINATION

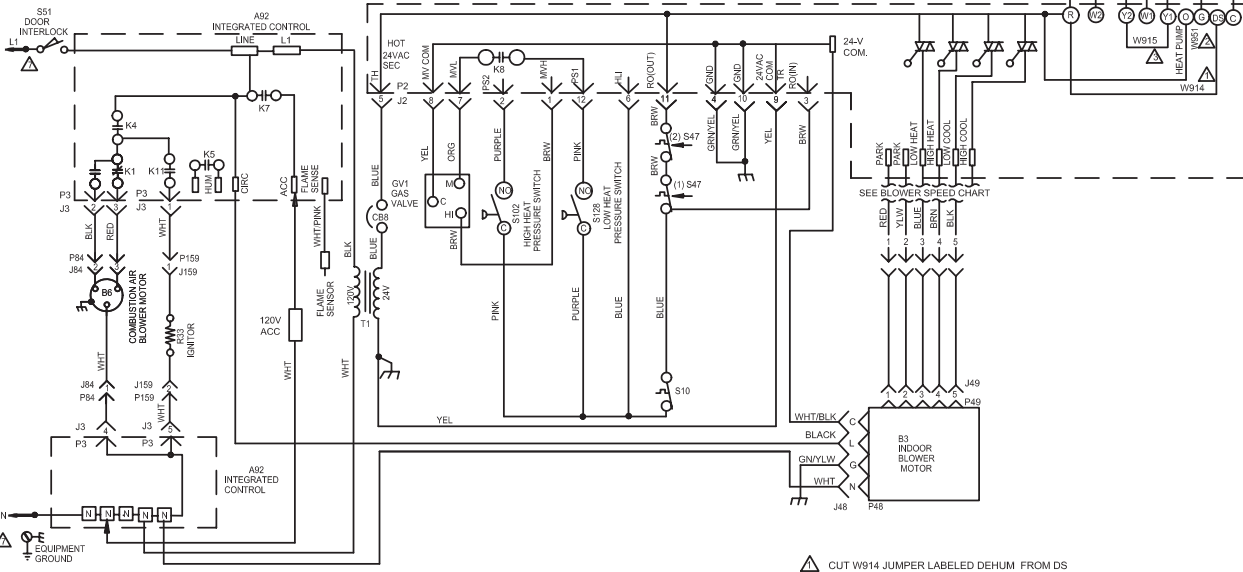
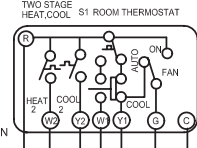

- ⚠ CUT W914 JUMPER LABELED DEHUM FROM DS TO R, AT A92 CONTROL BOARD, WHEN USED WITH ComfortSense 7000 THERMOSTAT
- ⚠ CUT W951 JUMPER FROM O TO R, LABELED "HEAT PUMP", AT A92 CONTROL BOARD, WHEN USED FOR DUAL FUEL APPLICATIONS
- ⚠ CUT W915 JUMPER LABELED "2 STAGE COMPR." FROM Y1 TO Y2 AT A92 CONTROL WHEN USED WITH A 2 STAGE COOL THERMOSTAT.
- ⚠ L13 USED ON 3/4 AND 1 HP ONLY
- ⚠ DIP SWITCH FACTORY DEFAULT IS FOR A TW STAGE THERMOSTAT
- ⚠ FIELD SUPPLIED ACC WIRE
- ⚠ USE COPPER CONDUCTORS ONLY
- ⚠ DH AND L TERMINALS NOT USED.
- ⚠ DO NOT USE RED (LOW SPEED) FOR HIGH HEAT ON ALL MODELS.

Wiring Diagram With Integrated Control 107048-XX

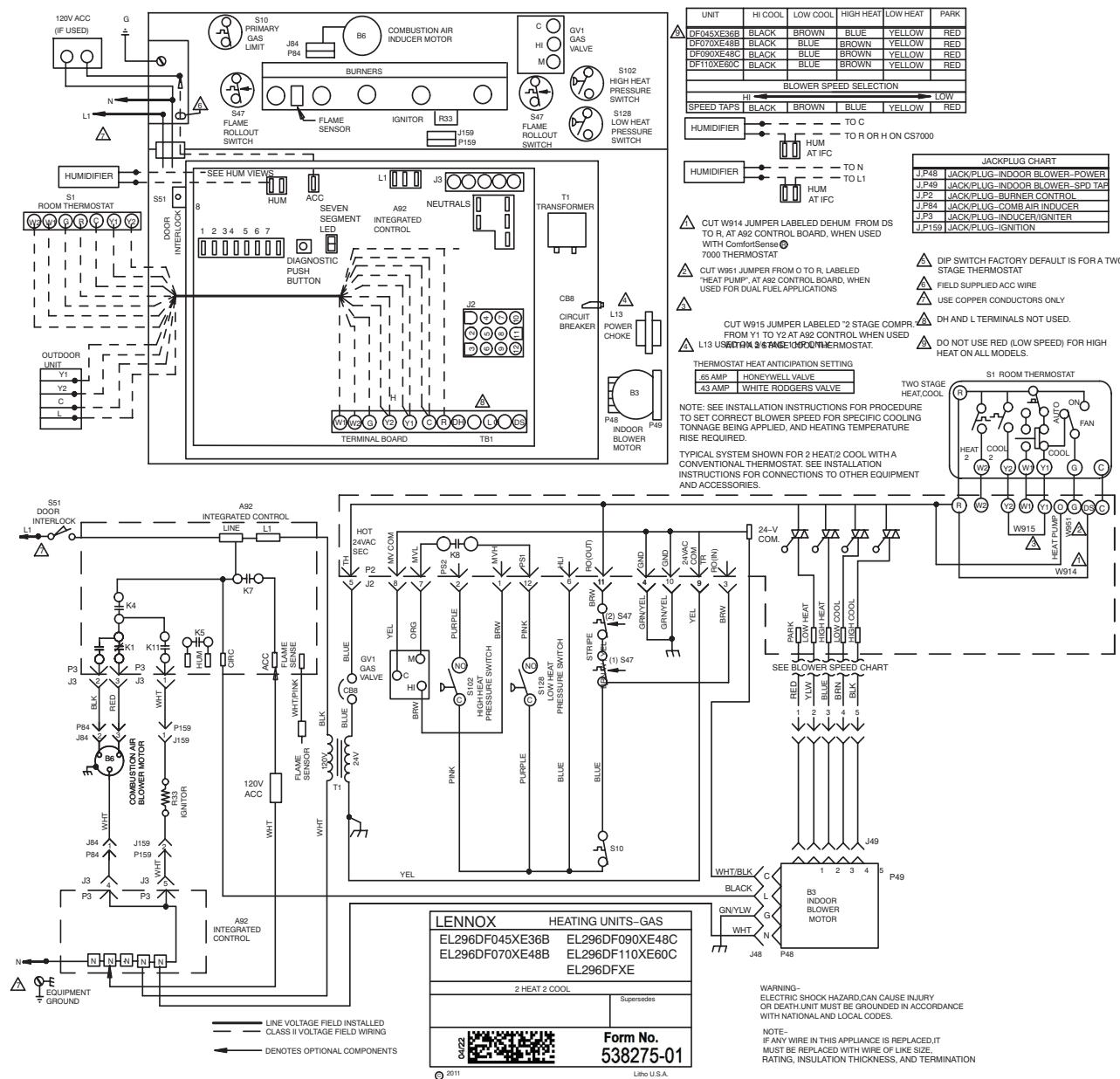

UNIT	HI COOL	LOW COOL	HIGH HEAT	LOW HEAT	PARK
DF045XE36B	BLACK	BROWN	BLUE	YELLOW	RED
DF070XE48B	BLACK	BLUE	BROWN	YELLOW	RED
DF090XE48C	BLACK	BLUE	BROWN	YELLOW	RED
DF110XE60C	BLACK	BLUE	BROWN	YELLOW	RED

BLOWER SPEED SELECTION					
SPEED TAPS	BLACK	BROWN	BLUE	YELLOW	RED
HUMIDIFIER	---	---	---	---	---
	TO C				
	TO R OR H ON CS7000				

JACKPLUG CHART	
J.P48	JACK-PLUG-INDOOR BLOWER-POWER
J.P49	JACK-PLUG-INDOOR BLOWER-SPD TAP
J.P2	JACK-PLUG-BURNER CONTROL
J.P84	JACK-PLUG-COMB AIR INDUCER
J.P3	JACK-PLUG-INDUCER/IGNITER
J.P159	JACK-PLUG-IGNITION

- △ CUT W914 JUMPER LABELED DEHUM FROM DS TO R, AT A92 CONTROL BOARD, WHEN USED WITH ComfortSense™ 7000 THERMOSTAT
- △ CUT W91 JUMPER FROM O TO R, LABELED "HEAT PUMP", AT A92 CONTROL BOARD, WHEN USED FOR DUAL FUEL APPLICATIONS
- △ CUT W915 JUMPER LABELED "2 STAGE COMPR." FROM Y1 TO Y2 AT A92 CONTROL WHEN USED WITH ComfortSense™ THERMOSTAT.
- △ L13 USED FOR 3 STAGE THERMOSTAT.

THERMOSTAT HEAT ANTICIPATION SETTING	
.65 AMP	HONEYWELL VALVE
.43 AMP	WHITE RODGERS VALVE

NOTE: SEE INSTALLATION INSTRUCTIONS FOR PROCEDURE TO SET CORRECT BLOWER SPEED FOR SPECIFIC COOLING TONNAGE BEING APPLIED, AND HEATING TEMPERATURE RISE REQUIRED.

TYPICAL SYSTEM SHOWN FOR 2 HEAT/2 COOL WITH A CONVENTIONAL THERMOSTAT. SEE INSTALLATION INSTRUCTIONS FOR CONNECTIONS TO OTHER EQUIPMENT AND ACCESSORIES.

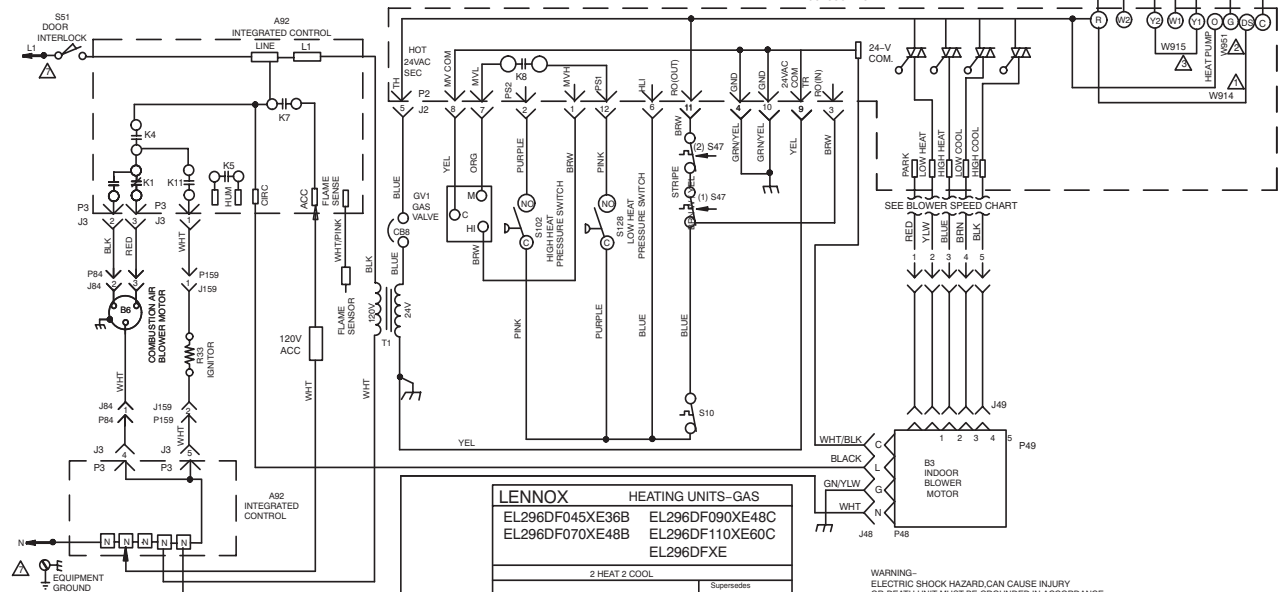
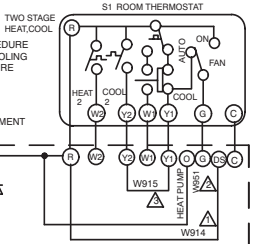

LENNOX HEATING UNITS-GAS	
EL296DF045XE36B	EL296DF090XE48C
EL296DF070XE48B	EL296DF110XE60C
EL296DFXE	
2 HEAT 2 COOL	
Supersedes	
Form No. 538275-01	
Lennox U.S.A.	

WARNING- ELECTRIC SHOCK HAZARD, CAN CAUSE INJURY OR DEATH. UNIT MUST BE GROUNDED IN ACCORDANCE WITH NATIONAL AND LOCAL CODES.

NOTE- IF ANY WIRE IN THIS APPLIANCE IS REPLACED IT MUST BE REPLACED WITH WIRE OF LIKE SIZE, RATING, INSULATION THICKNESS, AND TERMINATION

— LINE VOLTAGE FIELD INSTALLED
 - - - CLASS II VOLTAGE FIELD WIRING
 ← DENOTES OPTIONAL COMPONENTS

© 2011

Electronic Ignition

WARNING

Electric Shock Hazard. Can cause injury or death. Unit must be properly grounded in accordance with national and local codes.

WARNING

Fire Hazard. Use of aluminum wire with this product may result in a fire, causing property damage, severe injury or death. Use copper wire only with this product.

WARNING

Failure to use properly sized wiring and circuit breaker may result in property damage. Size wiring and circuit breaker(s) per Product Specifications bulletin (EHB) and unit rating plate.

The two-stage, variable speed integrated control used in EL296DFE units has an added feature of an internal Watchguard control. The feature serves as an automatic reset device for ignition control lockout caused by ignition failure. After one hour of continuous thermostat demand for heat, the Watchguard will break and remake thermostat demand to the furnace and automatically reset the control to begin the ignition sequence.

NOTE - The ignition control thermostat selection DIP switch is factory-set in the "TWO-STAGE" position.

Applications Using a Two-Stage Thermostat See figure 58 for ignition control sequence

A - Heating Sequence -- Integrated Control Thermostat Selection DIP Switch 1 OFF in "Two-Stage" Position (Factory Setting)

- 1 - On a call for heat, thermostat first-stage contacts close sending a signal to the integrated control. The integrated control runs a self-diagnostic program and checks high temperature limit switches for normally closed contacts and pressure switches for normally open contacts. The combustion air inducer is energized at low speed.
- 2 - Once the control receives a signal that the low pressure switch has closed, the combustion air inducer begins a 15-second pre-purge in low speed.

NOTE - If the low fire pressure switch does not close the combustion air inducer will switch to high fire. After a 15 second pre-purge the high fire pressure switch will close and the unit will begin operation on high fire. After 10 to 20 seconds of high fire operation the unit will switch to low fire.

- 3 - After the pre-purge is complete, a 20-second initial ignitor warm-up period begins. The combustion air inducer continues to operate at low speed.
- 4 - After the 20-second warm-up period has ended, the gas valve is energized on low fire (first stage) and ignition occurs. At the same time, the control module sends a signal to begin an indoor blower 30-second ON-delay. When the delay ends, the indoor blower motor is energized on the low fire heating speed, the HUM contacts close energizing the humidifier and 120V ACC terminal is energized. The furnace will continue this operation as long as the thermostat has a first-stage heating demand.

NOTE - If the indoor thermostat is set on *CONTINUOUS FAN ON* mode, the furnace will light on high fire (second-stage) for 60 seconds to improve heat exchanger warm up. After 60 second warm-up period, furnace will switch to low fire (first-stage).

- 5 - If second-stage heat is required, the thermostat second-stage heat contacts close and send a signal to the integrated control. The integrated control initiates a 30-second second-stage recognition delay.
- 6 - At the end of the recognition delay, the integrated control energizes the combustion air inducer at high speed. The control also checks the high fire (second stage) pressure switch to make sure it is closed. The high fire (second stage) gas valve is energized and the indoor blower motor is energized for operation at the high fire heating speed.
- 7 - When the demand for high fire (second stage) heat is satisfied, the combustion air inducer is switched to the low-fire heating speed and the high-fire (second stage) gas valve is de-energized. The low-fire (first stage) gas valve continues operation. The indoor blower motor is switched to the low-fire heating speed.
- 8 - When the thermostat demand for low-fire (first stage) heat is satisfied, the gas valve is de-energized and the field-selected indoor blower off delay begins. The combustion air inducer begins a 5-second post-purge period.
- 9 - When the combustion air post-purge period is complete, the inducer and the HUM contacts are de-energized. The indoor blower is de-energized at the end of the off delay as well as the 120V ACC terminal.

Applications Using A Single-Stage Thermostat

B - Heating Sequence -- Integrated Control Thermostat Selection DIP Switch 1 ON in "Single-Stage" Position

NOTE - In these applications, two-stage heat will be initiated by the integrated control if heating demand has not been satisfied after the field adjustable period (7 or 12 minutes).

- 1 - On a call for heat, thermostat first-stage contacts close sending a signal to the integrated control. The integrated control runs a self-diagnostic program and checks high temperature limit switches for normally closed contacts and pressure switches for normally open contacts. The combustion air inducer is energized at low speed.
- 2 - Once the control receives a signal that the low pressure switch has closed, the combustion air inducer begins a 15-second pre-purge in low speed.

NOTE - If the low fire pressure switch does not close the combustion air inducer will switch to high fire. After a 15 second pre-purge the high fire pressure switch will close and the unit will begin operation on high fire. After 10 to 20 seconds of high fire operation the unit will switch to low fire.

- 3 - After the pre-purge is complete, a 20-second initial ignitor warm-up period begins. The combustion air inducer continues to operate at low speed.

- 4 - After the 20-second warm-up period has ended, the gas valve is energized on low fire (first stage) and ignition occurs. At the same time, the control module sends a signal to begin an indoor blower 30-second ON-delay. When the delay ends, the indoor blower motor is energized on the low fire heating speed and the HUM contacts are energized. The integrated control also initiates a second-stage on delay (factory-set at 7 minutes; adjustable to 12 minutes).
- 5 - If the heating demand continues beyond the secondstage on delay, the integrated control energizes the combustion air inducer at high speed. The control also checks the high fire (second stage) pressure switch to make sure it is closed. The high fire (second stage) gas valve is energized and the indoor blower motor is energized for operation at the high fire heating speed.
- 6 - When the thermostat heating demand is satisfied, the combustion air inducer begins a 5-second low speed post-purge. The field-selected indoor blower off delay begins. The indoor blower operates at the low-fire heating speed.
- 7 - When the combustion air post-purge period is complete, the inducer and the HUM contacts are de-energized. The indoor blower is de-energized at the end of the off delay as well as the 120V ACC terminal.

VIII- EL296DFE Field Wiring Applications

TABLE 27

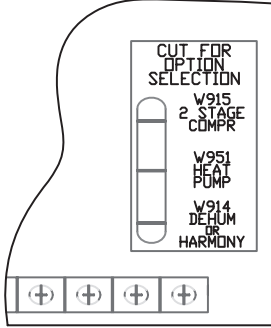
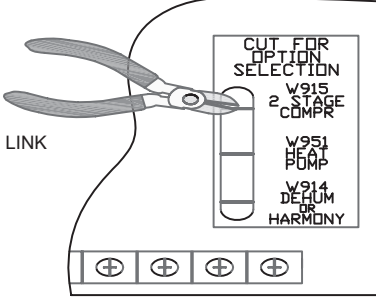
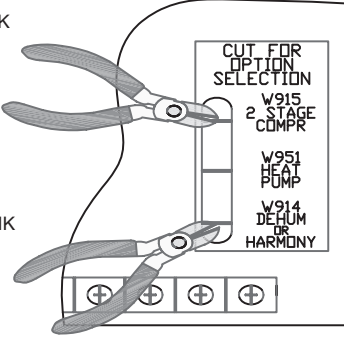
Thermostat	DIP Switch Settings and On-Board Links		Wiring Connections																														
	DIP Switch 1 Thermostat Heating Stages	On Board Links Must Be Cut To Select System Options																															
1 Heat / 1 Cool <i>NOTE - Use DIP switch 2 to set second-stage heat ON delay. OFF-7 minutes. ON-12 minutes.</i>	ON	DO NOT CUT ANY ON-BOARD LINKS 	<table border="0"> <tr> <td>S1 T'STAT</td> <td>FURNACE TERM. STRIP</td> <td>OUTDOOR UNIT</td> </tr> <tr> <td></td> <td>(DS)</td> <td></td> </tr> <tr> <td>(W2)</td> <td>(W2)</td> <td></td> </tr> <tr> <td>(W1)-----</td> <td>(W1)</td> <td></td> </tr> <tr> <td>(R)-----</td> <td>(R)</td> <td>*----- (R)</td> </tr> <tr> <td>(G)-----</td> <td>(G)</td> <td></td> </tr> <tr> <td>(C)-----</td> <td>(C)</td> <td>----- (C)</td> </tr> <tr> <td></td> <td>(Y2)</td> <td></td> </tr> <tr> <td>(Y)-----</td> <td>(Y1)</td> <td>----- (Y1)</td> </tr> <tr> <td></td> <td>(O)</td> <td></td> </tr> </table>	S1 T'STAT	FURNACE TERM. STRIP	OUTDOOR UNIT		(DS)		(W2)	(W2)		(W1)-----	(W1)		(R)-----	(R)	*----- (R)	(G)-----	(G)		(C)-----	(C)	----- (C)		(Y2)		(Y)-----	(Y1)	----- (Y1)		(O)	
S1 T'STAT	FURNACE TERM. STRIP	OUTDOOR UNIT																															
	(DS)																																
(W2)	(W2)																																
(W1)-----	(W1)																																
(R)-----	(R)	*----- (R)																															
(G)-----	(G)																																
(C)-----	(C)	----- (C)																															
	(Y2)																																
(Y)-----	(Y1)	----- (Y1)																															
	(O)																																
1 Heat / 2 Cool <i>NOTE - Use DIP switch 2 to set second-stage heat ON delay. OFF-7 minutes. ON-12 minutes.</i>	ON	CUT ON-BOARD LINK W915 2 STAGE COMPR 	<table border="0"> <tr> <td>S1 T'STAT</td> <td>FURNACE TERM. STRIP</td> <td>OUTDOOR UNIT</td> </tr> <tr> <td></td> <td>(DS)</td> <td></td> </tr> <tr> <td></td> <td>(W2)</td> <td></td> </tr> <tr> <td>(W)-----</td> <td>(W1)</td> <td></td> </tr> <tr> <td>(R)-----</td> <td>(R)</td> <td>*----- (R)</td> </tr> <tr> <td>(G)-----</td> <td>(G)</td> <td></td> </tr> <tr> <td>(C)-----</td> <td>(C)</td> <td>----- (C)</td> </tr> <tr> <td>(Y2)-----</td> <td>(Y2)</td> <td>----- (Y2)</td> </tr> <tr> <td>(Y1)-----</td> <td>(Y1)</td> <td>----- (Y1)</td> </tr> <tr> <td></td> <td>(O)</td> <td></td> </tr> </table>	S1 T'STAT	FURNACE TERM. STRIP	OUTDOOR UNIT		(DS)			(W2)		(W)-----	(W1)		(R)-----	(R)	*----- (R)	(G)-----	(G)		(C)-----	(C)	----- (C)	(Y2)-----	(Y2)	----- (Y2)	(Y1)-----	(Y1)	----- (Y1)		(O)	
S1 T'STAT	FURNACE TERM. STRIP	OUTDOOR UNIT																															
	(DS)																																
	(W2)																																
(W)-----	(W1)																																
(R)-----	(R)	*----- (R)																															
(G)-----	(G)																																
(C)-----	(C)	----- (C)																															
(Y2)-----	(Y2)	----- (Y2)																															
(Y1)-----	(Y1)	----- (Y1)																															
	(O)																																
1 Heat / 2 Cool with t'stat with humidity control <i>NOTE - Use DIP switch 2 to set second-stage heat ON delay. OFF-7 minutes. ON-12 minutes.</i>	ON	CUT ON-BOARD LINK W915 2 STAGE COMPR CUT ON-BOARD LINK W914 DEHUM OR HARMONY 	<table border="0"> <tr> <td>S1 T'STAT</td> <td>FURNACE TERM. STRIP</td> <td>OUTDOOR UNIT</td> </tr> <tr> <td>(DS)-----</td> <td>(DS)</td> <td></td> </tr> <tr> <td></td> <td>(W2)</td> <td></td> </tr> <tr> <td>(W1)-----</td> <td>(W1)</td> <td></td> </tr> <tr> <td>(R)-----</td> <td>(R)</td> <td>*----- (R)</td> </tr> <tr> <td>(G)-----</td> <td>(G)</td> <td></td> </tr> <tr> <td>(C)-----</td> <td>(C)</td> <td>----- (C)</td> </tr> <tr> <td>(Y2)-----</td> <td>(Y2)</td> <td>----- (Y2)</td> </tr> <tr> <td>(Y1)-----</td> <td>(Y1)</td> <td>----- (Y1)</td> </tr> <tr> <td></td> <td>(O)</td> <td></td> </tr> </table>	S1 T'STAT	FURNACE TERM. STRIP	OUTDOOR UNIT	(DS)-----	(DS)			(W2)		(W1)-----	(W1)		(R)-----	(R)	*----- (R)	(G)-----	(G)		(C)-----	(C)	----- (C)	(Y2)-----	(Y2)	----- (Y2)	(Y1)-----	(Y1)	----- (Y1)		(O)	
S1 T'STAT	FURNACE TERM. STRIP	OUTDOOR UNIT																															
(DS)-----	(DS)																																
	(W2)																																
(W1)-----	(W1)																																
(R)-----	(R)	*----- (R)																															
(G)-----	(G)																																
(C)-----	(C)	----- (C)																															
(Y2)-----	(Y2)	----- (Y2)																															
(Y1)-----	(Y1)	----- (Y1)																															
	(O)																																

* Not required on all units.

TABLE 27 Continued

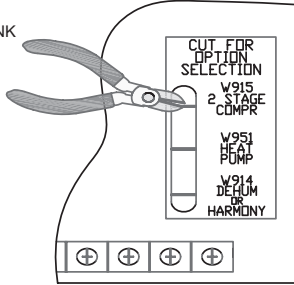
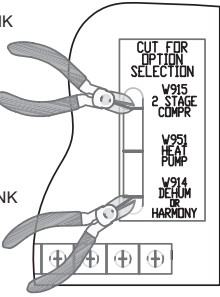
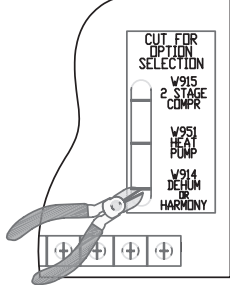
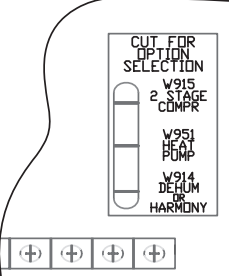
Thermostat	DIP Switch Settings and On-Board Links		Wiring Connections																														
	DIP Switch 1 Thermostat Heating Stages	On Board Links Must Be Cut To Select System Options																															
2 Heat / 2 Cool	OFF	<p>CUT ON-BOARD LINK W915 2 STAGE COMPR</p> 	<table border="0"> <thead> <tr> <th>S1 T'STAT</th> <th>FURNACE TERM. STRIP</th> <th>OUTDOOR UNIT</th> </tr> </thead> <tbody> <tr> <td>(DS)</td> <td>(DS)</td> <td></td> </tr> <tr> <td>(W2) ---</td> <td>(W2)</td> <td></td> </tr> <tr> <td>(W1) ---</td> <td>(W1)</td> <td></td> </tr> <tr> <td>(R) ---</td> <td>(R) --- *</td> <td>(R)</td> </tr> <tr> <td>(G) ---</td> <td>(G)</td> <td></td> </tr> <tr> <td>(C) ---</td> <td>(C) ---</td> <td>(C)</td> </tr> <tr> <td>(Y2) ---</td> <td>(Y2)</td> <td>(Y2)</td> </tr> <tr> <td>(Y1) ---</td> <td>(Y1)</td> <td>(Y1)</td> </tr> <tr> <td></td> <td>(O)</td> <td></td> </tr> </tbody> </table>	S1 T'STAT	FURNACE TERM. STRIP	OUTDOOR UNIT	(DS)	(DS)		(W2) ---	(W2)		(W1) ---	(W1)		(R) ---	(R) --- *	(R)	(G) ---	(G)		(C) ---	(C) ---	(C)	(Y2) ---	(Y2)	(Y2)	(Y1) ---	(Y1)	(Y1)		(O)	
S1 T'STAT	FURNACE TERM. STRIP	OUTDOOR UNIT																															
(DS)	(DS)																																
(W2) ---	(W2)																																
(W1) ---	(W1)																																
(R) ---	(R) --- *	(R)																															
(G) ---	(G)																																
(C) ---	(C) ---	(C)																															
(Y2) ---	(Y2)	(Y2)																															
(Y1) ---	(Y1)	(Y1)																															
	(O)																																
2 Heat / 2 Cool with t'stat with humidity control	OFF	<p>CUT ON-BOARD LINK W915 2 STAGE COMPR</p>  <p>CUT ON-BOARD LINK W914 DEHUM OR HARMONY</p>	<table border="0"> <thead> <tr> <th>S1 T'STAT</th> <th>FURNACE TERM. STRIP</th> <th>OUTDOOR UNIT</th> </tr> </thead> <tbody> <tr> <td>(DS) ---</td> <td>(DS)</td> <td></td> </tr> <tr> <td>(W2) ---</td> <td>(W2)</td> <td></td> </tr> <tr> <td>(W1) ---</td> <td>(W1)</td> <td></td> </tr> <tr> <td>(R) ---</td> <td>(R) --- *</td> <td>(R)</td> </tr> <tr> <td>(G) ---</td> <td>(G)</td> <td></td> </tr> <tr> <td>(C) ---</td> <td>(C) ---</td> <td>(C)</td> </tr> <tr> <td>(Y2) ---</td> <td>(Y2)</td> <td>(Y2)</td> </tr> <tr> <td>(Y1) ---</td> <td>(Y1)</td> <td>(Y1)</td> </tr> <tr> <td></td> <td>(O)</td> <td></td> </tr> </tbody> </table>	S1 T'STAT	FURNACE TERM. STRIP	OUTDOOR UNIT	(DS) ---	(DS)		(W2) ---	(W2)		(W1) ---	(W1)		(R) ---	(R) --- *	(R)	(G) ---	(G)		(C) ---	(C) ---	(C)	(Y2) ---	(Y2)	(Y2)	(Y1) ---	(Y1)	(Y1)		(O)	
S1 T'STAT	FURNACE TERM. STRIP	OUTDOOR UNIT																															
(DS) ---	(DS)																																
(W2) ---	(W2)																																
(W1) ---	(W1)																																
(R) ---	(R) --- *	(R)																															
(G) ---	(G)																																
(C) ---	(C) ---	(C)																															
(Y2) ---	(Y2)	(Y2)																															
(Y1) ---	(Y1)	(Y1)																															
	(O)																																
2 Heat / 1 Cool with t'stat with humidity control	OFF	<p>CUT ON-BOARD LINK W914 DEHUM OR HARMONY</p> 	<table border="0"> <thead> <tr> <th>S1 T'STAT</th> <th>FURNACE TERM. STRIP</th> <th>OUTDOOR UNIT</th> </tr> </thead> <tbody> <tr> <td>(DS) ---</td> <td>(DS)</td> <td></td> </tr> <tr> <td>(W2) ---</td> <td>(W2)</td> <td></td> </tr> <tr> <td>(W1) ---</td> <td>(W1)</td> <td></td> </tr> <tr> <td>(R) ---</td> <td>(R) --- *</td> <td>(R)</td> </tr> <tr> <td>(G) ---</td> <td>(G)</td> <td></td> </tr> <tr> <td>(C) ---</td> <td>(C) ---</td> <td>(C)</td> </tr> <tr> <td>(Y1) ---</td> <td>(Y1)</td> <td>(Y1)</td> </tr> <tr> <td></td> <td>(O)</td> <td></td> </tr> </tbody> </table>	S1 T'STAT	FURNACE TERM. STRIP	OUTDOOR UNIT	(DS) ---	(DS)		(W2) ---	(W2)		(W1) ---	(W1)		(R) ---	(R) --- *	(R)	(G) ---	(G)		(C) ---	(C) ---	(C)	(Y1) ---	(Y1)	(Y1)		(O)				
S1 T'STAT	FURNACE TERM. STRIP	OUTDOOR UNIT																															
(DS) ---	(DS)																																
(W2) ---	(W2)																																
(W1) ---	(W1)																																
(R) ---	(R) --- *	(R)																															
(G) ---	(G)																																
(C) ---	(C) ---	(C)																															
(Y1) ---	(Y1)	(Y1)																															
	(O)																																
2 Heat / 1 Cool	OFF	<p>DO NOT CUT ANY ON-BOARD LINKS</p> 	<table border="0"> <thead> <tr> <th>S1 T'STAT</th> <th>FURNACE TERM. STRIP</th> <th>OUTDOOR UNIT</th> </tr> </thead> <tbody> <tr> <td></td> <td>(DS)</td> <td></td> </tr> <tr> <td>(W2) ---</td> <td>(W2)</td> <td></td> </tr> <tr> <td>(W1) ---</td> <td>(W1)</td> <td></td> </tr> <tr> <td>(R) ---</td> <td>(R) --- *</td> <td>(R)</td> </tr> <tr> <td>(G) ---</td> <td>(G)</td> <td></td> </tr> <tr> <td>(C) ---</td> <td>(C)</td> <td>(C)</td> </tr> <tr> <td></td> <td>(Y2)</td> <td></td> </tr> <tr> <td>(Y) ---</td> <td>(Y1)</td> <td>(Y1)</td> </tr> <tr> <td></td> <td>(O)</td> <td></td> </tr> </tbody> </table>	S1 T'STAT	FURNACE TERM. STRIP	OUTDOOR UNIT		(DS)		(W2) ---	(W2)		(W1) ---	(W1)		(R) ---	(R) --- *	(R)	(G) ---	(G)		(C) ---	(C)	(C)		(Y2)		(Y) ---	(Y1)	(Y1)		(O)	
S1 T'STAT	FURNACE TERM. STRIP	OUTDOOR UNIT																															
	(DS)																																
(W2) ---	(W2)																																
(W1) ---	(W1)																																
(R) ---	(R) --- *	(R)																															
(G) ---	(G)																																
(C) ---	(C)	(C)																															
	(Y2)																																
(Y) ---	(Y1)	(Y1)																															
	(O)																																

* Not required on all units.

TABLE 27 Continued

Thermostat	DIP Switch Settings and On-Board Links		Wiring Connections																																													
	DIP Switch 1 Thermostat Heating Stages	On Board Links Must Be Cut To Select System Options																																														
<p>Dual Fuel Single Stage Heat Pump</p> <p>ComfortSense thermostat w/ dual fuel capa- bilities Capable of 2 stage gas heat control</p>	OFF	<p>CUT ON-BOARD LINK W915 HEAT PUMP</p>	<table border="0"> <tr> <td>T*STAT</td> <td>FURNACE TERM. STRIP</td> <td>HEAT PUMP</td> </tr> <tr> <td>(R)-----</td> <td>(R)-----</td> <td>(R)</td> </tr> <tr> <td>(H)-----</td> <td></td> <td></td> </tr> <tr> <td>(W2)-----</td> <td>(W2)-----</td> <td>67M41*</td> </tr> <tr> <td>(W1)-----</td> <td>(W1)-----</td> <td>(W1) ← (W1)</td> </tr> <tr> <td>(O)-----</td> <td>(O)-----</td> <td>(O)</td> </tr> <tr> <td>(L)-----</td> <td></td> <td>(L)</td> </tr> <tr> <td>(Y1)-----</td> <td>(Y1)-----</td> <td>(Y)</td> </tr> <tr> <td>(Y2)-----</td> <td></td> <td></td> </tr> <tr> <td>(G)-----</td> <td>(G)-----</td> <td></td> </tr> <tr> <td>(D)-----</td> <td>(DS)-----</td> <td></td> </tr> <tr> <td>(B)-----</td> <td>(Y2)-----</td> <td></td> </tr> <tr> <td>(C)-----</td> <td>(C)-----</td> <td>(C)</td> </tr> <tr> <td>(T)-----</td> <td></td> <td>outdoor sensor</td> </tr> <tr> <td>(T)-----</td> <td></td> <td></td> </tr> </table>	T*STAT	FURNACE TERM. STRIP	HEAT PUMP	(R)-----	(R)-----	(R)	(H)-----			(W2)-----	(W2)-----	67M41*	(W1)-----	(W1)-----	(W1) ← (W1)	(O)-----	(O)-----	(O)	(L)-----		(L)	(Y1)-----	(Y1)-----	(Y)	(Y2)-----			(G)-----	(G)-----		(D)-----	(DS)-----		(B)-----	(Y2)-----		(C)-----	(C)-----	(C)	(T)-----		outdoor sensor	(T)-----		
T*STAT	FURNACE TERM. STRIP	HEAT PUMP																																														
(R)-----	(R)-----	(R)																																														
(H)-----																																																
(W2)-----	(W2)-----	67M41*																																														
(W1)-----	(W1)-----	(W1) ← (W1)																																														
(O)-----	(O)-----	(O)																																														
(L)-----		(L)																																														
(Y1)-----	(Y1)-----	(Y)																																														
(Y2)-----																																																
(G)-----	(G)-----																																															
(D)-----	(DS)-----																																															
(B)-----	(Y2)-----																																															
(C)-----	(C)-----	(C)																																														
(T)-----		outdoor sensor																																														
(T)-----																																																
<p>Dual Fuel Two Stage Heat Pump</p> <p>ComfortSense thermostat w/ dual fuel capa- bilities Capable of 2 stage gas heat control</p>	OFF	<p>CUT ON-BOARD LINK W915 2 STAGE COMPR</p> <p>CUT ON-BOARD LINK W915 HEAT PUMP</p>	<table border="0"> <tr> <td>T*STAT</td> <td>FURNACE TERM. STRIP</td> <td>HEAT PUMP</td> </tr> <tr> <td>(R)-----</td> <td>(R)-----</td> <td>(R)</td> </tr> <tr> <td>(H)-----</td> <td></td> <td></td> </tr> <tr> <td>(W2)-----</td> <td>(W2)-----</td> <td>67M41*</td> </tr> <tr> <td>(W1)-----</td> <td>(W1)-----</td> <td>(W1) ← (W1)</td> </tr> <tr> <td>(O)-----</td> <td>(O)-----</td> <td>(O)</td> </tr> <tr> <td>(L)-----</td> <td></td> <td>(L)</td> </tr> <tr> <td>(Y1)-----</td> <td>(Y1)-----</td> <td>(Y1)</td> </tr> <tr> <td>(Y2)-----</td> <td></td> <td>(Y2)</td> </tr> <tr> <td>(G)-----</td> <td>(G)-----</td> <td></td> </tr> <tr> <td>(D)-----</td> <td>(DS)-----</td> <td></td> </tr> <tr> <td>(B)-----</td> <td>(Y2)-----</td> <td>Y2 out blue</td> </tr> <tr> <td>(C)-----</td> <td>(C)-----</td> <td>(C)</td> </tr> <tr> <td>(T)-----</td> <td></td> <td>outdoor sensor</td> </tr> <tr> <td>(T)-----</td> <td></td> <td></td> </tr> </table>	T*STAT	FURNACE TERM. STRIP	HEAT PUMP	(R)-----	(R)-----	(R)	(H)-----			(W2)-----	(W2)-----	67M41*	(W1)-----	(W1)-----	(W1) ← (W1)	(O)-----	(O)-----	(O)	(L)-----		(L)	(Y1)-----	(Y1)-----	(Y1)	(Y2)-----		(Y2)	(G)-----	(G)-----		(D)-----	(DS)-----		(B)-----	(Y2)-----	Y2 out blue	(C)-----	(C)-----	(C)	(T)-----		outdoor sensor	(T)-----		
T*STAT	FURNACE TERM. STRIP	HEAT PUMP																																														
(R)-----	(R)-----	(R)																																														
(H)-----																																																
(W2)-----	(W2)-----	67M41*																																														
(W1)-----	(W1)-----	(W1) ← (W1)																																														
(O)-----	(O)-----	(O)																																														
(L)-----		(L)																																														
(Y1)-----	(Y1)-----	(Y1)																																														
(Y2)-----		(Y2)																																														
(G)-----	(G)-----																																															
(D)-----	(DS)-----																																															
(B)-----	(Y2)-----	Y2 out blue																																														
(C)-----	(C)-----	(C)																																														
(T)-----		outdoor sensor																																														
(T)-----																																																

* Connect W1 to W1 ONLY if using defrost tempering kit 67M41

NOTE - **Do NOT** make a wire connection between the room thermostat L terminal and the L terminal of the furnace integrated control.

TABLE 27 Continued

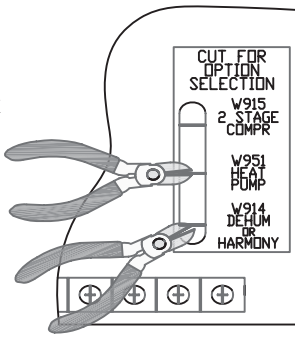
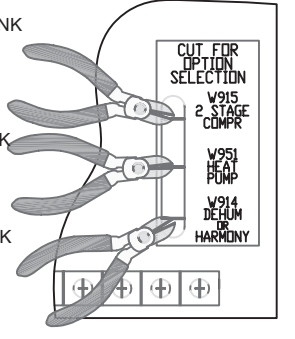
Thermostat	DIP Switch Settings and On-Board Links		Wiring Connections
	DIP Switch 1 Thermostat Heating Stages	On Board Links Must Be Cut To Select System Options	
<p>Dual Fuel Single Stage Heat Pump</p> <p>ComfortSense thermostat w/ dual fuel capabilities Capable of 2 stage gas heat control w/dehumidification control</p>	OFF	<p>CUT ON-BOARD LINK W951 HEAT PUMP</p> <p>CUT ON-BOARD LINK W914 DEHUM OR HARMONY</p> 	<p>T'STAT FURNACE TERM. STRIP HEAT PUMP</p> <p>(R) --- (R) --- (R)</p> <p>(H) --- (W2) --- (R) 67M41*</p> <p>(W2) --- (W1) ← ○ → (W1)</p> <p>(O) --- (O) --- (O)</p> <p>(L) --- (L) --- (L)</p> <p>(Y1) --- (Y1) --- (Y)</p> <p>(Y2) --- (Y2) --- (Y2)</p> <p>(G) --- (G) --- (G)</p> <p>(D) --- (DS) --- (D)</p> <p>(B) --- (Y2) --- (B)</p> <p>(C) --- (C) --- (C)</p> <p>(T) --- (T) --- (T)</p> <p>(T) --- (T) --- (T)</p> <p>outdoor sensor</p>
<p>Dual Fuel Two Stage Heat Pump</p> <p>ComfortSense thermostat w/ dual fuel capabilities Capable of 2 stage gas heat control w/dehumidification</p>	OFF	<p>CUT ON-BOARD LINK W915 2 STAGE COMP</p> <p>CUT ON-BOARD LINK W951 HEAT PUMP</p> <p>CUT ON-BOARD LINK W914 DEHUM OR HARMONY</p> 	<p>T'STAT FURNACE TERM. STRIP HEAT PUMP</p> <p>(R) --- (R) --- (R)</p> <p>(H) --- (W2) --- (R) 67M41*</p> <p>(W2) --- (W1) ← ○ → (W1)</p> <p>(O) --- (O) --- (O)</p> <p>(L) --- (L) --- (L)</p> <p>(Y1) --- (Y1) --- (Y1)</p> <p>(Y2) --- (Y2) --- (Y2)</p> <p>(G) --- (G) --- (G)</p> <p>(D) --- (DS) --- (D)</p> <p>(B) --- (Y2) --- (B) out blue</p> <p>(C) --- (C) --- (C)</p> <p>(T) --- (T) --- (T)</p> <p>(T) --- (T) --- (T)</p> <p>outdoor sensor</p>

* Connect W1 to W1 ONLY if using defrost tempering kit 67M41

NOTE - Do NOT make a wire connection between the room thermostat L terminal and the L terminal of the furnace integrated control.

IX- Troubleshooting

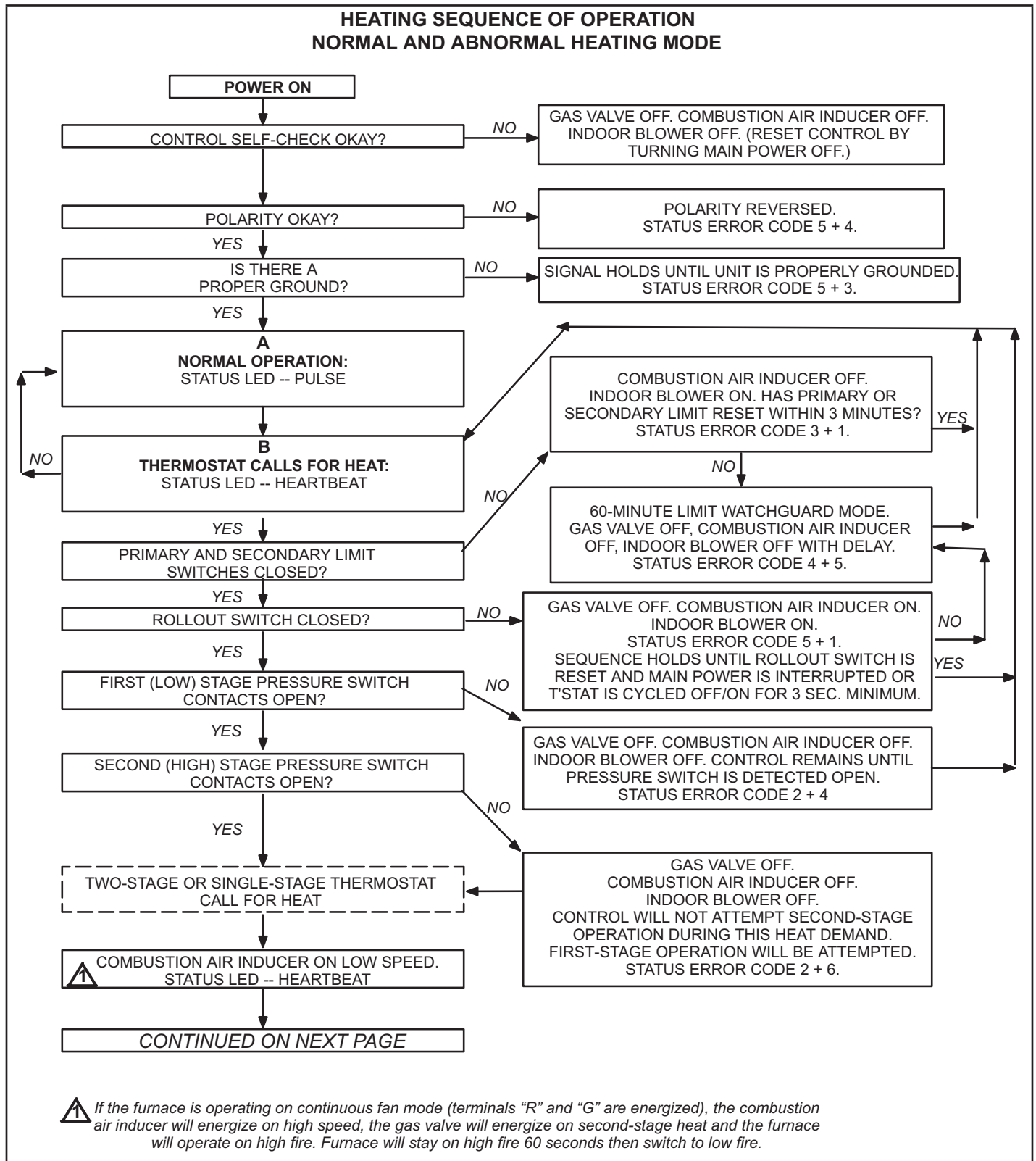

HEATING SEQUENCE OF OPERATION

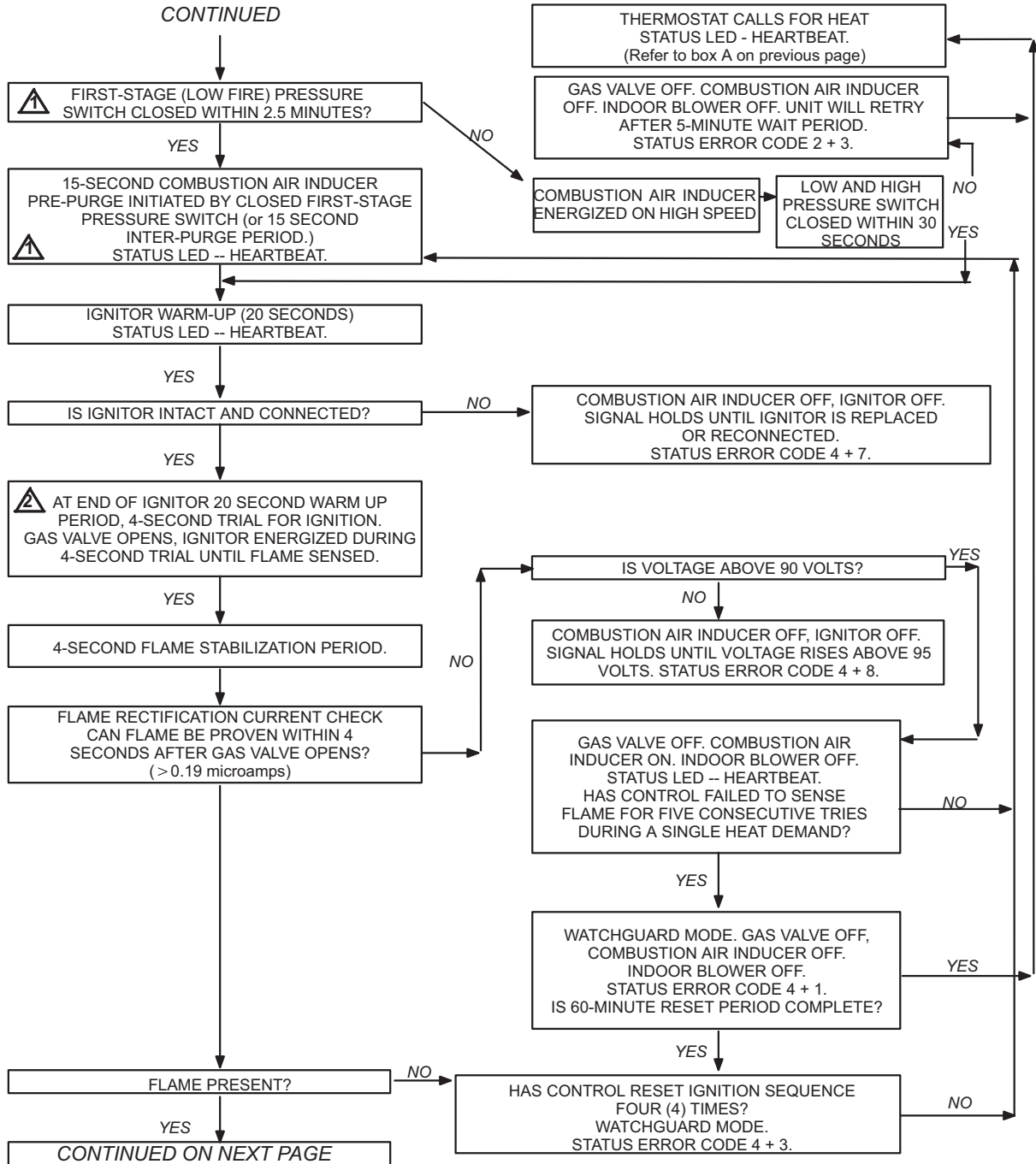

⚠ If the furnace is operating on continuous fan mode (terminals "R" and "G" are energized), the combustion air inducer will energize on high speed, the gas valve will energize on second-stage heat and the furnace will operate on high fire. Furnace will stay on high fire 60 seconds then switch to low fire.

⚠ If combustion air inducer is operating on high speed and gas valve is energized on second-stage heat, 20 seconds after flame is sensed furnace will switch to low fire.

HEATING SEQUENCE OF OPERATION

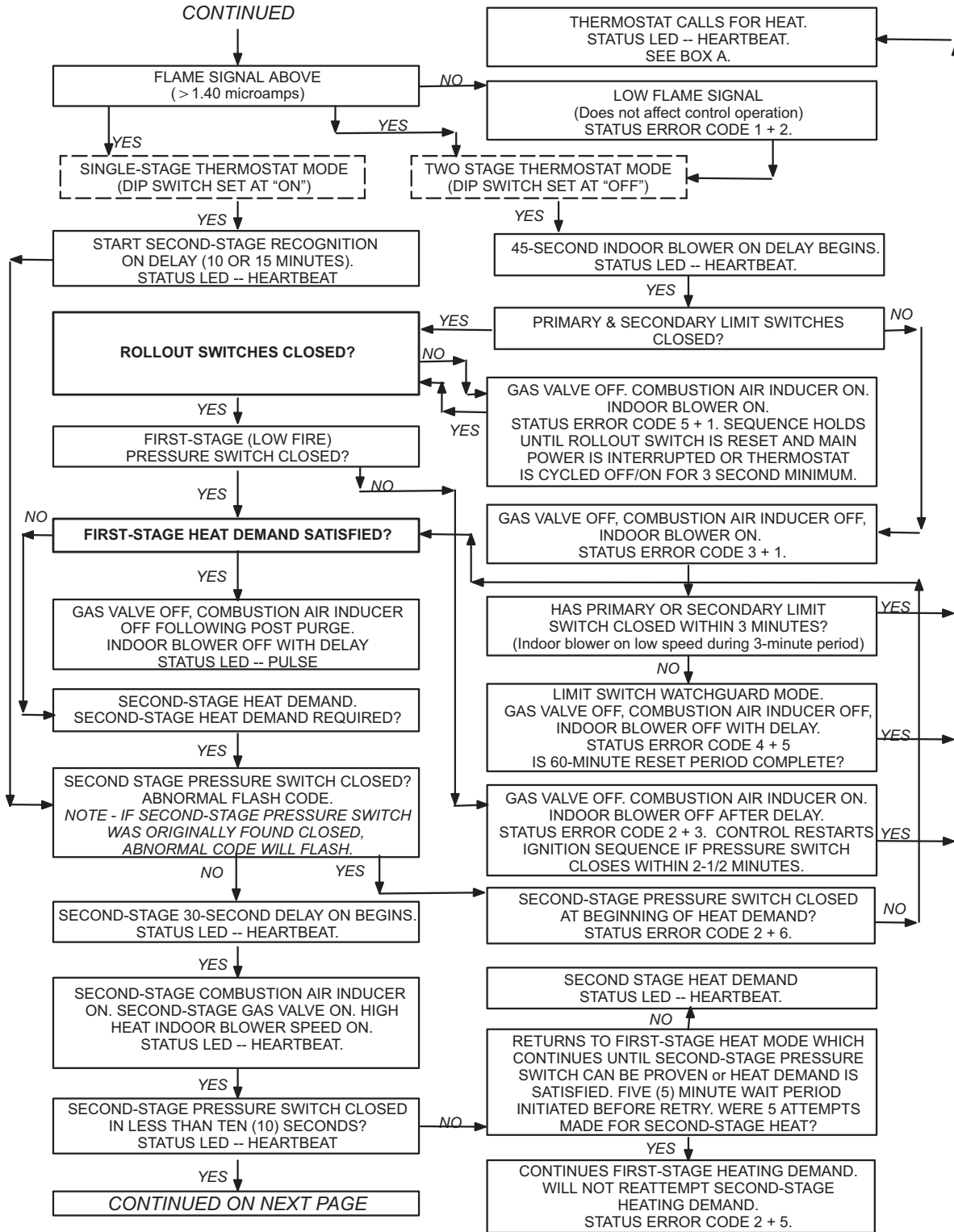

HEATING SEQUENCE OF OPERATION

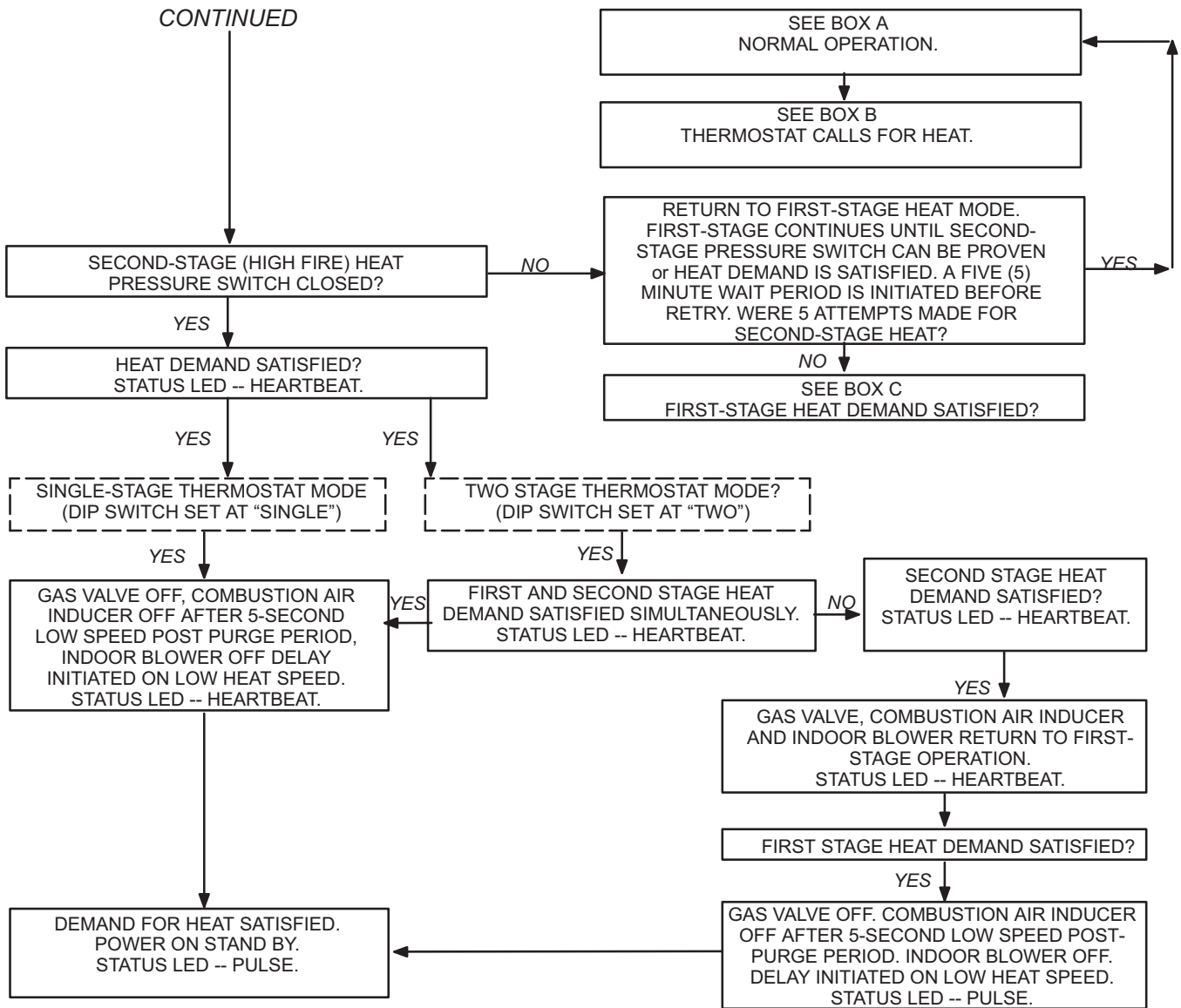

COOLING SEQUENCE OF OPERATION

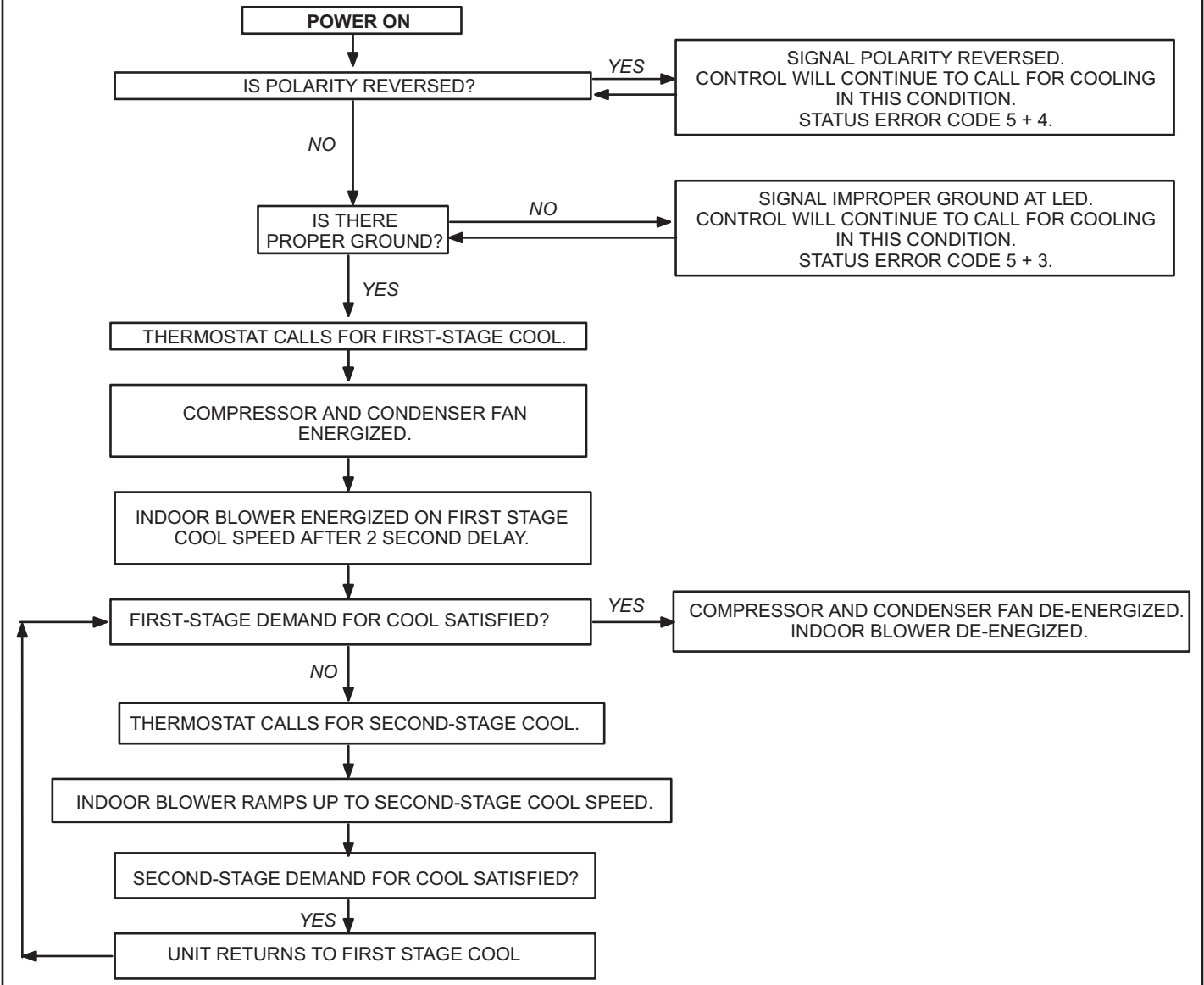

CONTINUOUS LOW SPEED FAN SEQUENCE OF OPERATION

