

COMMUNICATING ENABLED SL297UHNV SERIES UNITS

SL297UHNV series units are 90% efficiency gas furnaces used for upflow or horizontal applications only. SL297UHNV units are available in heating capacities of 40,000 to 80,000 Btuh and cooling applications up to 4 tons. Refer to Product Specifications Manual for proper sizing.

Units are factory equipped for use with natural gas. SL297UHNV model units are equipped with a communicating enabled SureLight® two-stage variable speed integrated control. All units use a redundant gas valve to assure safety shut-off as required by C.S.A.

All specifications in this manual are subject to change. Procedures outlined in this manual are presented as a recommendation only and do not supersede or replace local or state codes. In the absence of local or state codes, the guidelines and procedures outlined in this manual (except where noted) are recommendations only and do not constitute code.



TABLE OF CONTENTS

Specifications Page 2
 I Unit Components Page 11
 II Installation Page 33
 III Start Up Page 52
 IV Heating System Service Checks Page 53
 V Typical Operating Characteristics Page 59
 VI Maintenance Page 59
 VII Wiring and Sequence of Operation Page 62
 VIII Field Wiring and Jumper Settings Page 67
 IX Program Unit Capacity Size Mode Page 71
 X Troubleshooting Page 72

⚠ WARNING

Improper installation, adjustment, alteration, service or maintenance can cause property damage, personal injury or loss of life. Installation and service must be performed by a licensed professional HVAC installer (or equivalent), service agency or the gas supplier.

⚠ CAUTION

As with any mechanical equipment, contact with sharp sheet metal edges can result in personal injury. Take care while handling this equipment and wear gloves and protective clothing.

SPECIFICATIONS

Gas Heating Performance		Model No.	SL297UH040NV36B	SL297UH060NV36B
		¹ AFUE	97.5%	97.5%
High Fire	Input - Btuh		40,000	60,000
	Output - Btuh		39,000	58,000
		Temperature rise range - °F	30-60	50-80/25-55
		Gas Manifold Pressure (in. w.g.) Nat. Gas / LPG/Propane	3.5	3.5
Low Fire	Input - Btuh		26,000	39,000
	Output - Btuh		25,000	38,000
		Temperature rise range - °F	20 - 50	25 - 55
		Gas Manifold Pressure (in. w.g.) Nat. Gas / LPG/Propane	1.5	1.5
High static - in. w.g.	Heating		0.8	0.8
	Cooling		1.0	1.0
Connections in.	Intake / Exhaust Pipe (PVC)		2 / 2	2 / 2
	Gas pipe size IPS		1/2	1/2
	Condensate Drain Trap (PVC pipe) - i.d.		3/4	3/4
	with furnished 90° street elbow with field supplied (PVC coupling) - o.d.		3/4 slip x 3/4 Mipt 3/4 slip x 3/4 MPT	3/4 slip x 3/4 Mipt 3/4 slip x 3/4 MPT
Indoor Blower	Wheel nominal diameter x width - in.		10 x 9	10 x 9
	Motor output - hp		1/2	1/2
	Tons of add-on cooling		2 - 3	2 - 3
	Air Volume Range - cfm		440-1370	475-1380
Electrical Data	Voltage		120 volts - 60 hertz - 1 phase	
	Blower motor full load amps		7.7	7.7
	Maximum overcurrent protection		15	15
Shipping Data	lbs. - 1 package		125	130

NOTE - Filters and provisions for mounting are not furnished and must be field provided.

¹ Annual Fuel Utilization Efficiency based on DOE test procedures and according to FTC labeling regulations. Isolated combustion system rating for non-weatherized furnaces.

Gas Heating Performance		Model No.	SL297UH080NV48C	SL297UH080NV60C
		¹ AFUE	97.5%	97.5%
High Fire	Input - Btuh		80,000	80,000
	Output - Btuh		78,000	78,000
		Temperature rise range - °F	45-75	40-70
		Gas Manifold Pressure (in. w.g.) Nat. Gas / LPG/Propane	3.5	3.5
Low Fire	Input - Btuh		52,000	52,000
	Output - Btuh		51,000	51,000
		Temperature rise range - °F	30 - 60	25 - 55
		Gas Manifold Pressure (in. w.g.) Nat. Gas / LPG/Propane	1.5	1.5
High static - in. w.g.	Heating		0.8	0.8
	Cooling		1.0	1.0
Connections in.	Intake / Exhaust Pipe (PVC)		2 / 2	2 / 2
	Gas pipe size IPS		1/2	1/2
	Condensate Drain Trap (PVC pipe) - i.d.		3/4	3/4
	with furnished 90° street elbow with field supplied (PVC coupling) - o.d.		3/4 slip x 3/4 Mipt 3/4 slip x 3/4 MPT	3/4 slip x 3/4 Mipt 3/4 slip x 3/4 MPT
Indoor Blower	Wheel nominal diameter x width - in.		11 x 11	11 x 11
	Motor output - hp		3/4	1
	Tons of add-on cooling		2.5 - 4	3 - 5
	Air Volume Range - cfm		620-1730	870-2285
Electrical Data	Voltage		120 volts - 60 hertz - 1 phase	
	Blower motor full load amps		10.1	12.8
	Maximum overcurrent protection		15	15
Shipping Data	lbs. - 1 package		154	156

NOTE - Filters and provisions for mounting are not furnished and must be field provided.

¹ Annual Fuel Utilization Efficiency based on DOE test procedures and according to FTC labeling regulations. Isolated combustion system rating for non-weatherized furnaces.

OPTIONAL ACCESSORIES - ORDER SEPARATELY

NOTE - FURNACES CANNOT BE TWINNED!

			"B" Width Models	"C" Width Models
CABINET ACCESSORIES				
Horizontal Suspension Kit - Horizontal only			51W10	51W10
Return Air Base - Upflow only			50W98	50W99
High Performance Economizer (Commercial Only)			10U53	10U53
CONDENSATE DRAIN KITS				
Condensate Drain Heat Cable	6 ft.		26K68	26K68
	24 ft.		26K69	26K69
Crawl Space Vent Drain Kit	US		51W18	51W18
	Canada		15Z70	15Z70
CONTROLS				
iComfort® Communicating Thermostat			12U67	12U67
iComfort Wi-Fi® Thermostat			10F81	10F81
¹ Remote Outdoor Air Temperature Sensor (for dual fuel and Humiditrol®)			X2658	X2658
² Discharge Air Temperature Sensor			88K38	88K38
ComfortSense® 7500 Thermostat			13H14	13H14
³ Remote Outdoor Temperature Sensor (for dual fuel and Humiditrol)			X2658	X2658
FILTER KITS				
⁴ Air Filter and Rack Kit	Horizontal (end) Side Return	Size of filter - in.	87L96 - 18 x 25 x 1	87L97 - 20 x 25 x 1
		Single	44J22	44J22
		Ten Pack	66K63	66K63
		Size of filter - in.	16 x 25 x 1	16 x 25 x 1

BLOWER DATA

SL297UH040NV36B BLOWER PERFORMANCE (less filter)

BOTTOM RETURN AIR

0 through 0.8 in. w.g. (Heating) and 0 through 1.0 in. w.g. (Cooling) External Static Pressure Range

HEATING

¹ Heating Speed DIP Switch Settings	First Stage Heating Speed - cfm	Second Stage Heating Speed - cfm
+24%	1151	1153
+18%	1101	1099
+12%	816	1041
+6%	771	999
Factory Default	704	944
-6%	651	887
-12%	578	826
-18%	542	757

COOLING

¹ Cooling Speed DIP Switch Settings	First Stage Cooling Speed - cfm				Second Stage Cooling Speed - cfm			
	Low	Medium-Low	Medium-High	² High	Low	Medium-Low	Medium-High	² High
+	549	732	862	970	907	1072	1233	1373
Factory Default	521	637	760	873	830	975	1117	1268
-	441	560	684	784	736	874	1014	1142

SL297UH040NV36B BLOWER PERFORMANCE (less filter)

SINGLE SIDE RETURN AIR

0 through 0.8 in. w.g. (Heating) and 0 through 1.0 in. w.g. (Cooling) External Static Pressure Range

HEATING

¹ Heating Speed DIP Switch Settings	First Stage Heating Speed - cfm	Second Stage Heating Speed - cfm
+24%	863	1129
+18%	807	1087
+12%	761	1021
+6%	713	775
Factory Default	716	723
-6%	683	686
-12%	589	599
-18%	562	558

COOLING

¹ Cooling Speed DIP Switch Settings	First Stage Cooling Speed - cfm				Second Stage Cooling Speed - cfm			
	Low	Medium-Low	Medium-High	² High	Low	Medium-Low	Medium-High	² High
+	554	705	841	958	868	1057	1217	1344
Factory Default	509	606	724	875	799	969	1109	1253
-	436	559	675	754	703	860	1002	1137

¹ Cooling and heating speeds are based on a combination of DIP switch settings on the furnace control. Refer to Installation Instructions for specific DIP Switch Settings.² Factory default setting.

NOTES - The effect of static pressure is included in air volumes shown.

First stage HEAT is approximately 91% of the same second stage HEAT.

First stage COOL (two-stage air conditioning units only) is approximately 70% of the same second stage COOL speed position.

Continuous Fan Only speed is selectable at 28%, 38%, 70% and 100% of the selected second stage cooling speed - minimum 250 cfm.

Lennox iHarmony® Zoning System Applications - Minimum blower speed is 250 cfm.

BLOWER DATA

SL297UH040NV36B BLOWER PERFORMANCE (less filter)

SINGLE SIDE RETURN AIR WITH OPTIONAL RETURN AIR BASE

0 through 0.8 in. w.g. (Heating) and 0 through 1.0 in. w.g. (Cooling) External Static Pressure Range

HEATING

¹ Heating Speed DIP Switch Settings	First Stage Heating Speed - cfm	Second Stage Heating Speed - cfm
+24%	886	905
+18%	825	859
+12%	802	819
+6%	769	770
Factory Default	688	736
-6%	634	678
-12%	635	605
-18%	547	553

COOLING

¹ Cooling Speed DIP Switch Settings	First Stage Cooling Speed - cfm				Second Stage Cooling Speed - cfm			
	Low	Medium-Low	Medium-High	² High	Low	Medium-Low	Medium-High	² High
+	542	698	835	947	886	1034	1201	1320
Factory Default	462	634	735	855	808	949	1096	1248
-	413	534	678	779	734	868	987	1130

SL297UH060NV36B BLOWER PERFORMANCE (less filter)

BOTTOM RETURN AIR

0 through 0.8 in. w.g. (Heating) and 0 through 1.0 in. w.g. (Cooling) External Static Pressure Range

HEATING

¹ Heating Speed DIP Switch Settings	First Stage Heating Speed - cfm	Second Stage Heating Speed - cfm
+24%	1106	1234
+18%	1047	1158
+12%	989	1110
+6%	940	1054
Factory Default	886	999
-6%	837	947
-12%	780	882
-18%	722	826

COOLING

¹ Cooling Speed DIP Switch Settings	First Stage Cooling Speed - cfm				Second Stage Cooling Speed - cfm			
	Low	Medium-Low	Medium-High	² High	Low	Medium-Low	Medium-High	² High
+	611	739	843	949	879	1046	1212	1380
Factory Default	554	681	783	883	816	952	1107	1254
-	486	630	712	802	739	876	1006	1132

¹ Cooling and heating speeds are based on a combination of DIP switch settings on the furnace control. Refer to Installation Instructions for specific DIP Switch Settings.² Factory default setting.

NOTES - The effect of static pressure is included in air volumes shown.

First stage HEAT is approximately 91% of the same second stage HEAT.

First stage COOL (two-stage air conditioning units only) is approximately 70% of the same second stage COOL speed position.

Continuous Fan Only speed is selectable at 28%, 38%, 70% and 100% of the selected second stage cooling speed - minimum 250 cfm.

Lennox iHarmony® Zoning System Applications - Minimum blower speed is 250 cfm.

BLOWER DATA

SL297UH060NV36B BLOWER PERFORMANCE (less filter)

SINGLE SIDE RETURN AIR

0 through 0.8 in. w.g. (Heating) and 0 through 1.0 in. w.g. (Cooling) External Static Pressure Range

HEATING

¹ Heating Speed DIP Switch Settings	First Stage Heating Speed - cfm	Second Stage Heating Speed - cfm
+24%	1114	1237
+18%	1063	1168
+12%	1010	1106
+6%	951	1064
Factory Default	892	1003
-6%	837	942
-12%	761	869
-18%	693	809

COOLING

¹ Cooling Speed DIP Switch Settings	First Stage Cooling Speed - cfm				Second Stage Cooling Speed - cfm			
	Low	Medium-Low	Medium-High	² High	Low	Medium-Low	Medium-High	² High
+	599	749	867	981	892	1057	1229	1404
Factory Default	549	656	754	866	775	958	1115	1279
-	475	609	680	773	708	854	1011	1147

SL297UH060NV36B BLOWER PERFORMANCE (less filter)

SINGLE SIDE RETURN AIR WITH OPTIONAL RETURN AIR BASE

0 through 0.8 in. w.g. (Heating) and 0 through 1.0 in. w.g. (Cooling) External Static Pressure Range

HEATING

¹ Heating Speed DIP Switch Settings	First Stage Heating Speed - cfm	Second Stage Heating Speed - cfm
+24%	1098	1229
+18%	1039	1168
+12%	992	1104
+6%	930	1051
Factory Default	885	996
-6%	822	937
-12%	773	878
-18%	717	817

COOLING

¹ Cooling Speed DIP Switch Settings	First Stage Cooling Speed - cfm				Second Stage Cooling Speed - cfm			
	Low	Medium-Low	Medium-High	² High	Low	Medium-Low	Medium-High	² High
+	578	746	847	957	889	1042	1197	1364
Factory Default	556	665	764	864	799	949	1093	1249
-	485	593	706	783	721	845	988	1122

¹ Cooling and heating speeds are based on a combination of DIP switch settings on the furnace control. Refer to Installation Instructions for specific DIP Switch Settings.

² Factory default setting.

NOTES - The effect of static pressure is included in air volumes shown.

First stage HEAT is approximately 91% of the same second stage HEAT.

First stage COOL (two-stage air conditioning units only) is approximately 70% of the same second stage COOL speed position.

Continuous Fan Only speed is selectable at 28%, 38%, 70% and 100% of the selected second stage cooling speed - minimum 250 cfm.

Lennox iHarmony® Zoning System Applications - Minimum blower speed is 250 cfm.

BLOWER DATA

SL297UH080NV48C BLOWER PERFORMANCE (less filter)

BOTTOM RETURN AIR

0 through 0.8 in. w.g. (Heating) and 0 through 1.0 in. w.g. (Cooling) External Static Pressure Range

HEATING

¹ Heating Speed DIP Switch Settings	First Stage Heating Speed - cfm	Second Stage Heating Speed - cfm
+24%	1499	1640
+18%	1427	1546
+12%	1361	1472
+6%	1294	1399
Factory Default	1219	1315
-6%	1176	1242
-12%	1090	1173
-18%	1007	1077

COOLING

¹ Cooling Speed DIP Switch Settings	First Stage Cooling Speed - cfm				Second Stage Cooling Speed - cfm			
	Low	Medium-Low	Medium-High	² High	Low	Medium-Low	Medium-High	² High
+	797	954	1071	1241	1102	1304	1508	1713
Factory Default	713	873	969	1147	1006	1186	1392	1588
-	623	767	880	1025	911	1068	1252	1422

SL297UH080NV48C BLOWER PERFORMANCE (less filter)

SINGLE SIDE RETURN AIR

0 through 0.8 in. w.g. (Heating) and 0 through 1.0 in. w.g. (Cooling) External Static Pressure Range

HEATING

¹ Heating Speed DIP Switch Settings	First Stage Heating Speed - cfm	Second Stage Heating Speed - cfm
+24%	1433	1542
+18%	1353	1480
+12%	1275	1398
+6%	1229	1334
Factory Default	1154	1253
-6%	1093	1181
-12%	1024	1107
-18%	958	1054

COOLING

¹ Cooling Speed DIP Switch Settings	First Stage Cooling Speed - cfm				Second Stage Cooling Speed - cfm			
	Low	Medium-Low	Medium-High	² High	Low	Medium-Low	Medium-High	² High
+	792	959	1118	1264	1104	1302	1530	1730
Factory Default	844	876	1008	1162	1001	1202	1397	1612
-	643	771	908	1055	915	1090	1253	1443

¹ Cooling and heating speeds are based on a combination of DIP switch settings on the furnace control. Refer to Installation Instructions for specific DIP Switch Settings.² Factory default setting.

NOTES - The effect of static pressure is included in air volumes shown.

First stage HEAT is approximately 91% of the same second stage HEAT.

First stage COOL (two-stage air conditioning units only) is approximately 70% of the same second stage COOL speed position.

Continuous Fan Only speed is selectable at 28%, 38%, 70% and 100% of the selected second stage cooling speed - minimum 380 cfm.

Lennox iHarmony® Zoning System Applications - Minimum blower speed is 380 cfm.

BLOWER DATA

SL297UH080NV48C BLOWER PERFORMANCE (less filter)

SINGLE SIDE RETURN AIR WITH OPTIONAL RETURN AIR BASE

0 through 0.8 in. w.g. (Heating) and 0 through 1.0 in. w.g. (Cooling) External Static Pressure Range

HEATING

¹ Heating Speed DIP Switch Settings	First Stage Heating Speed - cfm	Second Stage Heating Speed - cfm
+24%	1,407	1,528
+18%	1,342	1,461
+12%	1,283	1,388
+6%	1,217	1,304
Factory Default	1,152	1,237
-6%	1,080	1,150
-12%	1,015	1,114
-18%	953	1,038

COOLING

¹ Cooling Speed DIP Switch Settings	First Stage Cooling Speed - cfm				Second Stage Cooling Speed - cfm			
	Low	Medium-Low	Medium-High	² High	Low	Medium-Low	Medium-High	² High
+	831	969	1103	1269	1096	1323	1541	1731
Factory Default	753	905	1008	1150	1005	1208	1385	1605
-	806	807	932	1045	920	1102	1269	1451

SL297UH080NV60C BLOWER PERFORMANCE (less filter)

BOTTOM RETURN AIR

0 through 0.8 in. w.g. (Heating) and 0 through 1.0 in. w.g. (Cooling) External Static Pressure Range

HEATING

¹ Heating Speed DIP Switch Settings	First Stage Heating Speed - cfm	Second Stage Heating Speed - cfm
+24%	1591	2135
+18%	1503	2026
+12%	1426	1921
+6%	1334	1828
Factory Default	1277	1716
-6%	1197	1609
-12%	1124	1504
-18%	1037	1402

COOLING

¹ Cooling Speed DIP Switch Settings	First Stage Cooling Speed - cfm				Second Stage Cooling Speed - cfm			
	Low	Medium-Low	Medium-High	² High	Low	Medium-Low	Medium-High	² High
+	1094	1253	1388	1580	1584	1825	2065	2286
Factory Default	984	1155	1284	1445	1454	1659	1881	2092
-	868	1021	1152	1302	1301	1490	1693	1890

¹ Cooling and heating speeds are based on a combination of DIP switch settings on the furnace control. Refer to Installation Instructions for specific DIP Switch Settings.² Factory default setting.

NOTES - The effect of static pressure is included in air volumes shown.

First stage HEAT is approximately 91% of the same second stage HEAT.

First stage COOL (two-stage air conditioning units only) is approximately 70% of the same second stage COOL speed position.

Continuous Fan Only speed is selectable at 28%, 38%, 70% and 100% of the selected second stage cooling speed - minimum 450 cfm.

Lennox iHarmony® Zoning System Applications - Minimum blower speed is 250 for 080NV48C and 450 cfm for 080NV60C.

BLOWER DATA

SL297UH080NV60C BLOWER PERFORMANCE (less filter)

SINGLE SIDE RETURN AIR - Air volumes in **bold** require Optional Return Air Base and field fabricated transition to accommodate 20 x 25 x 1 in. cleanable air filter in order to maintain proper air velocity across the filter.

0 through 0.8 in. w.g. (Heating) and 0 through 1.0 in. w.g. (Cooling) External Static Pressure Range

HEATING

¹ Heating Speed DIP Switch Settings	First Stage Heating Speed - cfm	Second Stage Heating Speed - cfm
+24%	1491	2027
+18%	1414	1901
+12%	1351	1801
+6%	1284	1722
Factory Default	1211	1621
-6%	1130	1517
-12%	1048	1407
-18%	993	1323

COOLING

¹ Cooling Speed DIP Switch Settings	First Stage Cooling Speed - cfm				Second Stage Cooling Speed - cfm			
	Low	Medium-Low	Medium-High	² High	Low	Medium-Low	Medium-High	² High
+	1094	1279	1430	1609	1599	1823	2051	2239
Factory Default	1003	1160	1308	1454	1438	1649	1863	2097
-	894	1044	1166	1309	1301	1490	1683	1897

¹ Cooling and heating speeds are based on a combination of DIP switch settings on the furnace control. Refer to Installation Instructions for specific DIP Switch Settings.

² Factory default setting.

NOTES - The effect of static pressure is included in air volumes shown.

First stage HEAT is approximately 91% of the same second stage HEAT.

First stage COOL (two-stage air conditioning units only) is approximately 70% of the same second stage COOL speed position.

Continuous Fan Only speed is selectable at 28%, 38%, 70% and 100% of the selected second stage cooling speed - minimum 450 cfm.

Lennox iHarmony® Zoning System Applications - Minimum blower speed is 450 cfm.

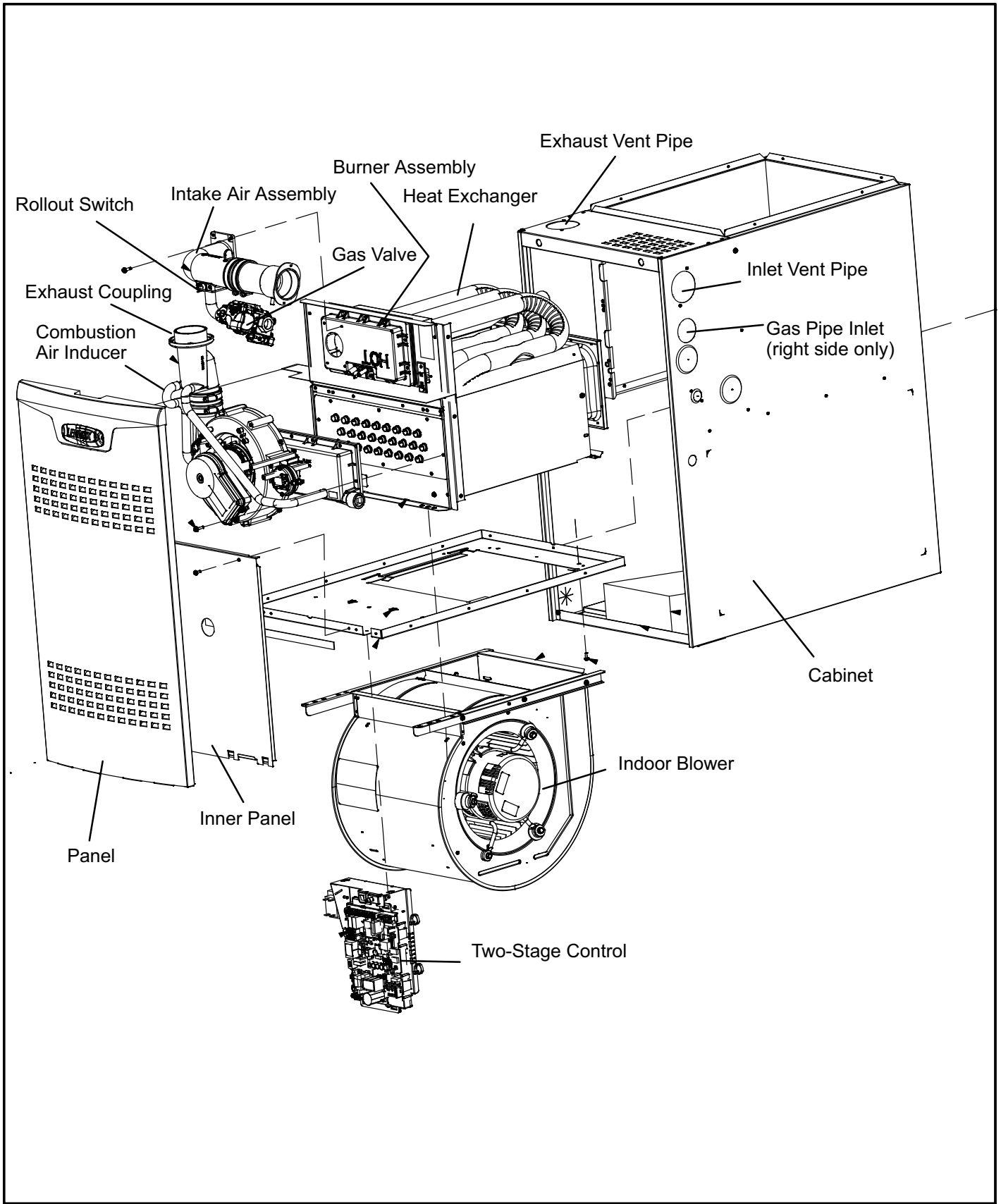
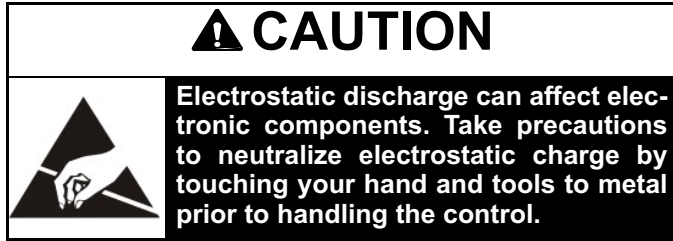

FIGURE 1

I-UNIT COMPONENTS

SL297UHNV unit components are shown in figure 1. The gas valve, combustion air inducer and burners can be accessed by removing the access panel. Electrical components are in the control box (figure 2) found in the blower section.

SL297UHNV units are factory equipped with a bottom return air panel in place. The panel is designed to be field removed as required for bottom air return. Markings are provided for side return air and may be cut out in the field.



A- Control Box

1. Control Transformer (T1)

A transformer located in the control box provides power to the low voltage section of the unit. Transformers on all models are rated 40VA with a 120V primary and a 24V secondary.

2. Door Interlock Switch (S51)

A door interlock switch rated 14A at 125VAC is wired in series with line voltage. When the inner blower access panel is removed the unit will shut down.

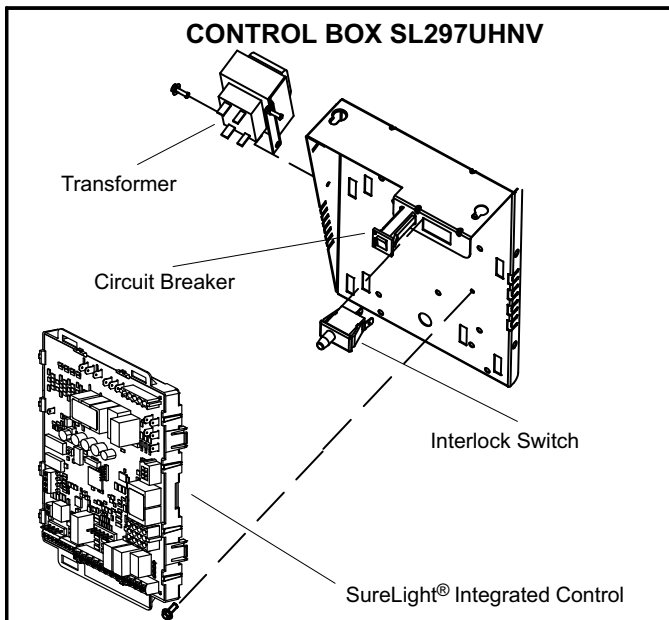

FIGURE 2

3. Circuit Breaker (CB8)

A 24V circuit breaker is also located in the control box. The switch provides overcurrent protection to the transformer (T1). The breaker is rated 3A at 32V. If the current exceeds this limit the breaker will trip and all unit operation will shutdown. The breaker can be manually reset by pressing the button on the face. See figure 3.

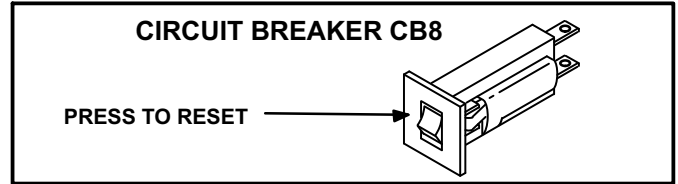

FIGURE 3



4. Integrated Control (A92)

Units are equipped with the iComfort® enabled SureLight® two-stage, variable speed integrated control. This control is used with the iComfort Wi-Fi® thermostat as part of a communicating comfort system. The control can also operate with a non-communicating conventional single or two-stage thermostat. The system consists of a ignition / blower control (figures 4 and 5) with control pin designations in tables 1, 2 and 3 and ignitor. The control and ignitor work in combination to ensure furnace ignition and ignitor durability. The control provides gas ignition, safety checks and indoor blower control with two-stage gas heating. The furnace combustion air inducer, gas valve and indoor blower are controlled in response to various system inputs such as thermostat signal, pressure and limit switch signal and flame signal. The control features a seven-segment LED display, indicating furnace status (including indoor blower) and error codes. The LED flashes in single digits. For example using table 5 under LIMIT CODE, an "E" followed by "2" followed by "5" followed by "0", the limit switch circuit is open. The control also has two unpowered (dry) 1/4" contacts for a humidifier and a 120 volt accessory terminal. Both rated at (1) one amp each.

Electronic Ignition

At the beginning of the heat cycle the integrated control monitors the first stage and second stage combustion air inducer prove switch. The control will not begin the heating cycle if the first stage prove switch is closed (by-passed). Likewise the integrated control will not begin the second stage heating cycle if the second stage prove switch is closed, and will remain in first stage heat. However, if the second stage prove switch closes during the first stage heat pre-purge, the control will allow second stage heat. Once the first stage prove switch is determined to be open,

the combustion air inducer is energized on low (first stage) heat speed. When the differential in the prove switch is great enough, the prove switch closes and a 15-second pre-purge begins.

NOTE - During abnormal conditions such as low supply voltage or low outdoor temperatures and the low fire pressure switch does not close, the combustion air inducer will switch to high fire. After a 15 second pre-purge the high fire pressure switch will close and the unit will begin operation on high fire. After 10 to 20 seconds of high fire operation the unit will switch to low fire

After the 15-second pre-purge period, the SureLight® ignitor warms up for 20 seconds after which the gas valve opens for a 4-second trial for ignition. The ignitor remains energized during the trial until flame is sensed. If ignition is not proved during the 4-second period, the control will try four more times with an inter purge and warm-up time between trials of 35 seconds. After a total of five trials for ignition (including the initial trial), the control goes into Watch-guard-Flame Failure mode. After a 60-minute reset period, the control will begin the ignition sequence again.

Two Stage Operation / Thermostat Selection DIP Switch

The control can be utilized in two modes: SINGLE-STAGE thermostat or TWO-STAGE thermostat. The thermostat selection is made using a DIP switch and must be positioned for the particular application. DIP switch 1, labeled T^hSTAT HEAT STAGE is factory-set in the OFF position for use with a two-stage thermostat. Move the DIP switch to ON for use with a single stage thermostat.

While in the single-stage thermostat mode, the burners will always fire on first-stage heat. The combustion air inducer will operate on low speed and indoor blower will operate on low heat speed. The unit will switch to second stage heat after a "recognition period". DIP switch 2, labeled SECOND STAGE DELAY, is factory set in the OFF position for a 7 minute recognition period. The switch can be moved to the ON position for a 12 minute recognition period, after which time the unit will switch to second-stage heat. While in the two-stage thermostat mode, the burners will fire on first-stage heat. The combustion air inducer will operate on low speed and indoor blower will operate on low heat speed. The unit will switch to second-stage heat on call from the indoor thermostat. If there is a simultaneous call for first and second stage heat, the unit will fire an first stage heat and switch to second stage heat after 30 seconds of operation. See Sequence of Operation flow charts in the back of this manual for more detail.

TABLE 1

SureLight® Control 5 Pin Terminal Designation	
PIN #	Function
1	Ignitor
2	Combustion Air Inducer High Speed
3	Combustion Air Inducer Low Speed
4	Combustion Air Inducer Neutral
5	Ignitor Neutral

TABLE 2

SureLight® Control 12 Pin Terminal Designation	
PIN #	Function
1	Gas Valve Second Stage
2	Second Stage Prove Switch
3	Rollout Switch In
4	Ground
5	24V Hot
6	Primary Limit In
7	Gas Valve First Stage
8	Gas Valve Common
9	24V Neutral
10	Ground
11	Rollout Switch Out
12	First Stage Prove Switch

TABLE 3

SureLight® Control 6 Pin Terminal Designation	
PIN #	Function
1	Data Input From Motor
2	Common
3	Not Used
4	Data Output To Motor
5	5 Volt Bias Supply
6	Not Used

INTEGRATED CONTROL

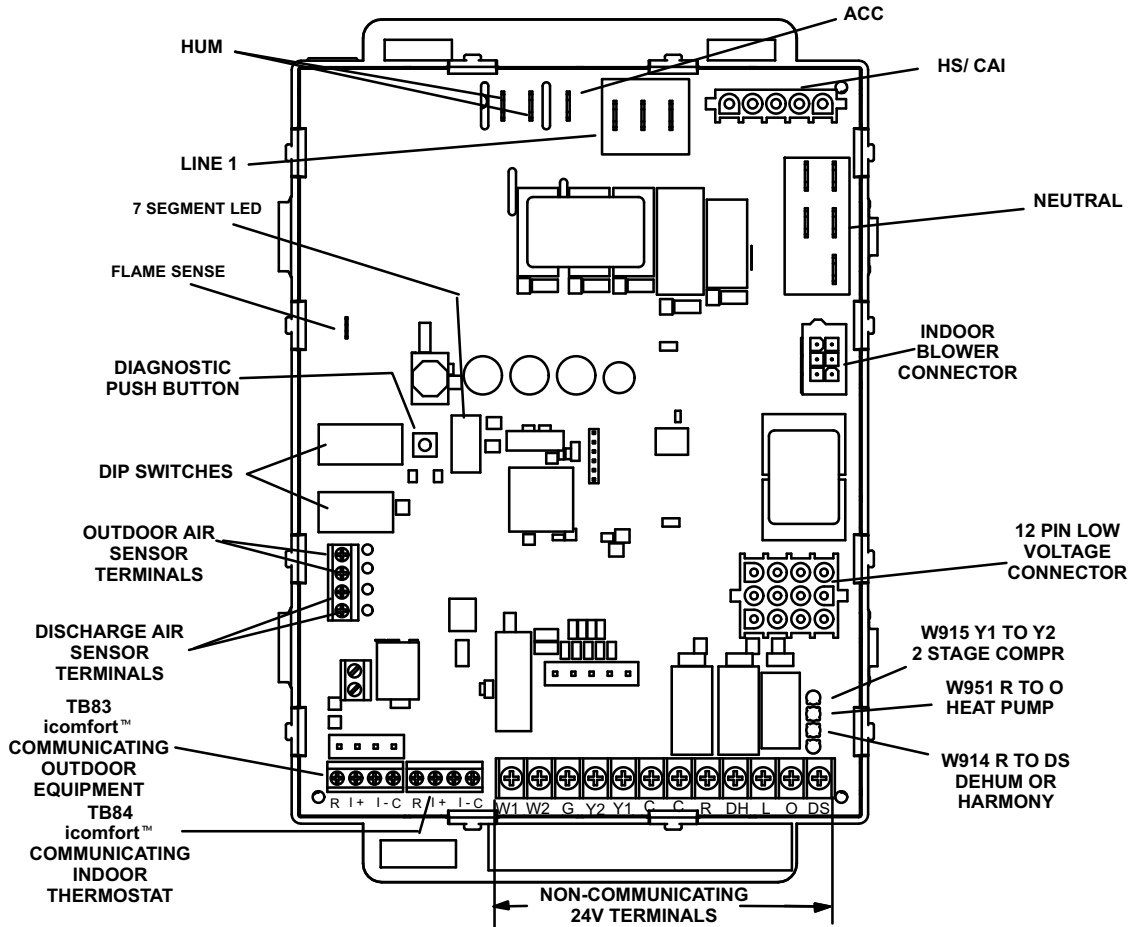

TB83 icomfort™ Communicating Outdoor Equipment

R = 24VAC
 I+ = DATA HIGH CONNECTION
 I- = DATA LOW CONNECTION
 C = 24VAXC COMMON

TB84 icomfort™ Communicating Indoor Thermostat

R = 24VAC
 I+ = DATA HIGH CONNECTION
 I- = DATA LOW CONNECTION
 C = 24VAXC COMMON

1/4" QUICK CONNECT TERMINALS

HUM = UNPOWERED NORMALLY OPEN (DRY) CONTACTS
 XMFR = 120 VAC OUTPUT TO TRANSFORMER
 LI = 120 VAC INPUT TO CONTROL
 ACC = 120 VAC OUTPUT TO OPTIONAL ACCESSORY
 NEUTRALS = 120 VAC NEUTRAL

THERMOSTAT CONNECTIONS (TB1)

DS = DEHUMIDIFICATION SIGNAL
 W2 = HEAT DEMAND FROM 2ND STAGE T/STAT
 W1 = HEAT DEMAND FROM 1ST STAGE T/STAT
 R = CLASS 2 VOLTAGE TO THERMOSTAT
 G = MANUAL FAN FROM T/STAT
 C = THERMOSTAT SIGNAL GROUND CONNECTED TO TRANSFORMER GRD (TR) & CHASIS GROUND (GRD)
 Y1 = THERMOSTAT 1ST STAGE COOL SIGNAL
 Y2 = THERMOSTAT 2ND STAGE COOL SIGNAL
 O = THERMOSTAT SIGNAL TO HEAT PUMP REVERSING VALVE
 DH = DEHUMIDIFICATION OUTPUT COMMUNICATING THERMOSTAT ONLY
 L = USE ONLY WITH A COMMUNICATING THERMOSTAT AND A NON-COMMUNICATING OUTDOOR UNIT

FIGURE 4

INTEGRATED CONTROL CONFIGURATION GUIDE

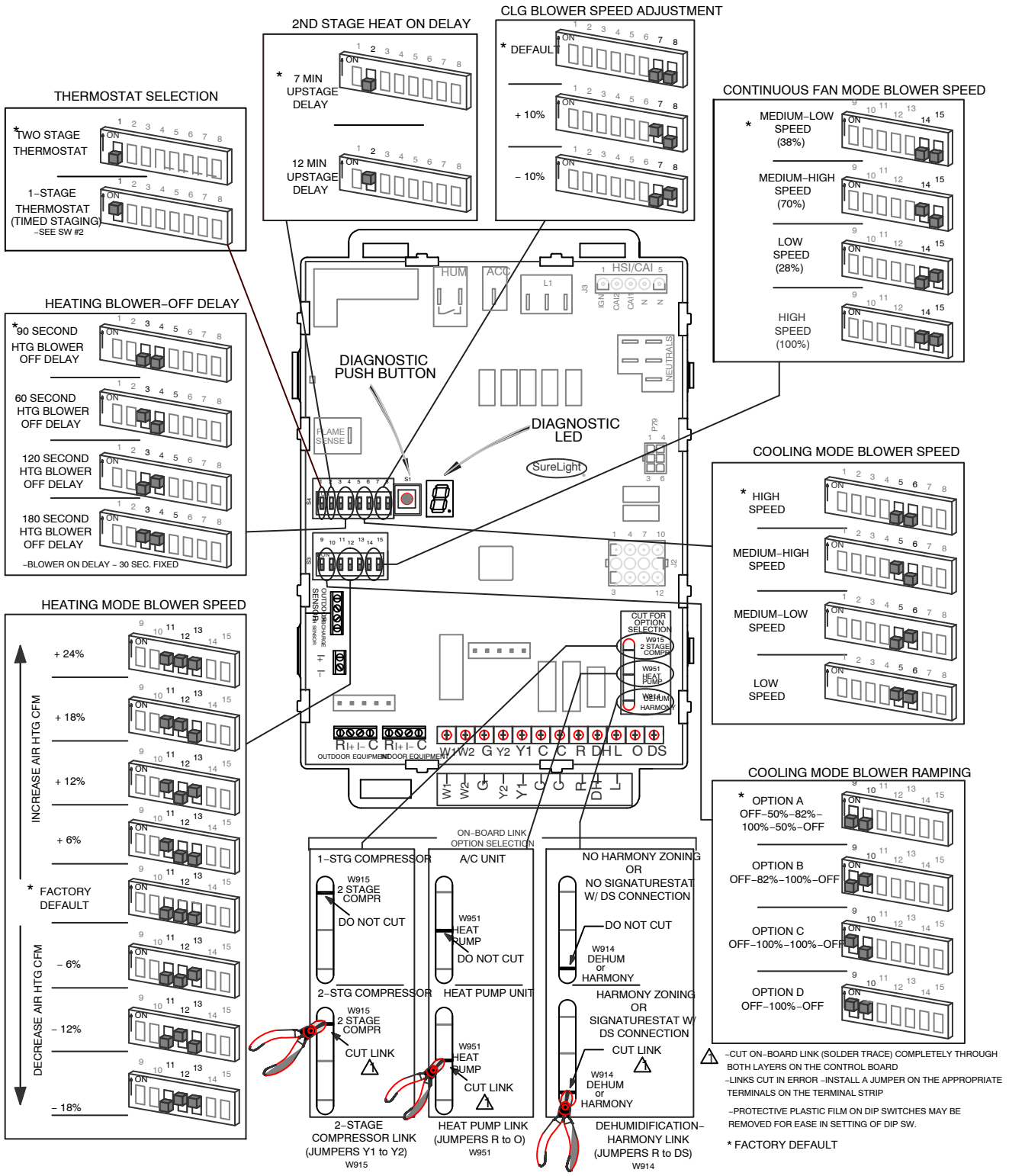



FIGURE 5

TABLE 4
Integrated Control Diagnostic Modes

Display	Action (when button released)
No change (idle)*	Remain in idle mode
Solid "E"	Enter diagnostic recall mode
Solid "F"	Enter flame signal mode
Solid "D"	Discharge Air Installed
Solid "P" (variable speed only)	Program unit capacity/size (Unit Code)
Two horizontal bars 	Soft disable

* No change implies the display will continue to show whatever is currently being displayed for normal operation (blinking decimal, active error code, heat state, etc).

Diagnostic LED (Figure 4)

The seven-segment diagnostic LED displays operating status, target airflow, error codes and other information. The table beginning on Page 16 lists diagnostic LED codes.

Diagnostic Push Button (Figure 4)

The diagnostic push button is located adjacent to the seven-segment diagnostic LED. This button is used to enable the Error Code Recall "E" mode, the Flame Signal "F" mode and "P" the Program Unit Capacity/Size mode. Press the button and hold it to cycle through a menu of options. Every five seconds a new menu item will be displayed. When the button is released, the displayed item will be selected. Once all items in the menu have been displayed, the menu resumes from the beginning until the button is released.

Error Code Recall Mode

Select "E" from the menu to access the most recent 10 error codes. Select "c" from the Error Code Recall menu to clear all error codes. Button must be pressed a second time while "c" is flashing to confirm command to delete codes. Press the button until a solid "≡" is displayed to exit the Error Code Recall mode.

Flame Signal Mode

Select "F" from the menu to access the flame signal mode. The integrated control will display the flame current on seven-segment LED in in micro amps (uA).

Flame signal mode is exited after any of the following:

- Power is reset
- Pressing and holding push button until 3 horizontal lines "≡" are displayed
- 10 minutes after entering the flame sense mode.

Program Unit Capacity/Size Mode

After the "P" is selected (by releasing the push button) the integrated control will start flashing the "P" on display for 90 seconds. If push button is pressed again and held during that time, the control will start to display characters corresponding to different variable speed furnace models for 3 seconds each. While the wanted character-model is displayed push button has to be released. Selected option will flash display for 10 seconds and during that time push button has to be pressed and held for 5 seconds. Once control accepts new setting it will store data in non-volatile memory and reset itself. If 10 seconds expires or push button is held less than 5 seconds, control will exit field test mode and go into idle without changing programming the unit size.

Soft Disable

Soft disabling is when thermostat finds a device on the BUS that it does not recognize and the thermostat sends a the device a message to be in soft disabling mode until properly configured. Two horizontal bars will display.

Steps to follow if the damper control module is displaying the soft disable code.

- 1- Confirm proper wiring between all devices (thermostat, damper control module, indoor and outdoor).
- 2- Cycle power to the control that is displaying the soft disable code.
- 3- Put the room thermostat through set up.
- 4- Go to **setup / system devices / thermostat / edit /** then push **reset**.
- 5- Go to **setup / system devices / thermostat / edit /** then push **resetAll**.

TABLE 5
Integrated Diagnostic Codes/Status of Equipment

Code	Diagnostic Codes/Status of Equipment	Action Required to Clear and Recover
.	Idle mode (Decimal blinks at 1 Hertz -- 0.5 second ON, 0.5 second OFF).	
A	Cubic feet per minute (cfm) setting for indoor blower (1 second ON, 0.5 second OFF) / cfm setting for current mode displayed.	
C	Cooling stage (1 second ON, 0.5 second OFF) / 1 or 2 displayed / Pause / cfm setting displayed / Pause / Repeat codes).	
d	Dehumidification mode (1 second ON) / 1 second OFF) / cfm setting displayed / Pause / Repeat Codes).	
h	Heat pump stage (1 second ON, 0.5 second OFF) / % of input rate displayed / Pause / cfm setting / Pause / Repeat codes.	
H	Gas Heat Stage (1 second ON, 0.5 second OFF) / 1 or 2 displayed / Pause / cfm setting displayed / Pause / Repeat codes. Blinking during ignition.	
dF	Defrost mode.	
U	Discharge Air Temperature	
E 105	Device communication problem - No other devices on RS BUS (Communication system).	Equipment is unable to communicate. Indicates numerous message errors. In most cases errors are related to electrical noise. Make sure high voltage power is separated from RSBus. Check for mis-wired and/or loose connections between the stat, indoor unit and outdoor unit. Check for a high voltage source of noise close to the system. Fault clears after communication is restored.
E 110	Low line voltage.	Line Voltage Low (Voltage lower than nameplate rating). Check power line voltage and correct. Alarm clears 5 seconds after fault recovered.
E 111	Line voltage polarity reversed.	Reverse line power voltage wiring. System resumes normal operation 5 seconds after fault recovered.
E 112	Ground not detected	System shuts down. Provide proper earth ground. System resumes normal operation 5 seconds after fault recovered.
E 113	High line voltage.	Line Voltage High (Voltage higher than nameplate rating). Provide power voltage within proper range. System resumes normal operation 5 seconds after fault recovered.
E 114	Line voltage frequency out-of-range.	No 60 Hertz Power. Check voltage and line power frequency. Correct voltage and frequency problems. System resumes normal operation 5 seconds after fault recovered.
E 115	Low 24V - Control will restart if the error recovers.	24-Volt Power Low (Range is 18 to 30 volts). Check and correct voltage. Check for additional power-robbing equipment connected to system. May require installation of larger VA transformer to be installed in furnace / air handler. Clears after fault recovered.
E 116	High 24V.	24 Volt Power High (Range is 18 to 30 volts). Check and correct voltage. Check for proper line voltage (120V, 240V, etc.) to equipment. Clears when control senses proper voltage.
E 117	Poor ground detected (Warning only)	Provide proper grounding for unit. Check for proper earth ground to the system. Warning only will clear 30 seconds after fault recovered.
E 120	Unresponsive device. Communication only.	Usually caused by delay in outdoor unit responding to indoor unit polling. Recycle power. Check all wiring connections. Cleared after unresponsive device responds to any inquiry.

TABLE 5 Continued

Code	Diagnostic Codes/Status of Equipment	Action Required to Clear and Recover
E 124	Active communicating thermostat signal missing for more than 3 minutes.	Equipment lost communication with the thermostat. Check four wiring connections, ohm wires and cycle power at the thermostat. Alert stops all services and waits for heartbeat message from thermostat (sub-net controller). Cleared after valid thermostat (sub-net controller) message is received.
E 125	Control failed self-check, internal error, failed hardware. Will restart if error recovers. Integrated control not communicating. Covers hardware errors (flame sense circuit faults, pin shorts, etc.).	Hardware problem on the control. Cycle power on control. Replace if problem prevents service and is persistent. Critical alert. Cleared 300 seconds after fault recovered.
E 126	Control internal communication problem.	Hardware problem on the control. Cycle power on control. Replace if problem prevents service and is persistent. Cleared 300 seconds after fault recovered.
E 131	Corrupted control parameters (Verify configuration of system). Communicating only.	Reconfigure the system. Replace control if heating or cooling is not available. Only applicable in the communicating mode, not in startup. Exit from Commissioning and Execute 'Set Factory Default mode'. Control will still operate on default parameter settings.
E 180	Outdoor air temperature sensor failure. Only shown if shorted or out-of-range.	Compare outdoor sensor resistance to temperature/resistance charts in unit installation instructions. Replace sensor pack if necessary. At beginning of (any) configuration, furnace or air handler control will sense outdoor air and discharge air temperature sensor(s). If detected (reading in range), appropriate feature will be set as 'installed' and that could be seen in 'About' screen. In normal operation after control recognizes sensors, alarm will be sent if valid temperature reading is lost. To get rid of setting and alarm, redo configuration and make sure that temperature sensor is marked as 'not installed' in Indoor Unit 'About' screen. When Indoor unit control is replaced, thermostat will 'tell' new control if temperature sensor is in system or not. Clears 30 seconds after fault recovered.
E 200	Hard lockout - Rollout circuit open or previously open.	Correct cause of rollout trip, or replace flame rollout switch. Test furnace operation. Cleared after fault recovered.
E 201	Indoor blower communication failure - Unable to communicate with blower motor.	Indoor blower communication failure (including power outage). Lost communication with indoor blower motor. Possible causes: motor not powered, loose wiring. Problem may be on control or motor side. Cleared after fault recovered.
E 202	Indoor blower motor mis-match - Indoor motor horsepower does not match unit capacity. See Page 70.	Incorrect appliance capacity code selected. Check for proper configuring under: Unit Size Codes for Furnace/Air Handler on configuration guide or in installation instructions. Cleared after the correct match is detected following a reset. (Remove thermostat from system while applying power and reprogramming.)
E 203	Appliance capacity / size is NOT programmed. Invalid unit codes refer to configuration flow chart. See Page 70.	No appliance capacity code selected. Check for proper configuring under: Unit Size Codes for Furnace on configuration guide or in installation instructions. Critical Alert. Cleared after valid unit code is read following a reset. (Remove thermostat from system while applying power and reprogramming.)
E 204	Gas valve mis-wired.	Check gas valve operation and wiring. Clears when repaired.
E 205	Gas valve control relay contact shorted.	Check wiring on control and gas valve. If wiring is correct, replace control.

TABLE 5 Continued

Code	Diagnostic Codes/Status of Equipment	Action Required to Clear and Recover
E 206	Gas valve second-stage relay failure	Furnace will operate on 1 st stage for remainder of the heating demand. Will clear after fault recovered. If unable to operate 2nd stage, replace control.
E 207	Hot surface ignitor sensed open	Measure resistance of hot surface ignitor. Replace if open or not within specified range found in IOM. Resumes normal operation after fault is cleared.
E 223	Low pressure switch failed open.	Check pressure (inches w.c.) of low pressure switch closing on heat call. Measure operating pressure (inches w.c.). Inspect vent and combustion air inducer for correct operation and restriction. Resumes normal operation after fault is cleared
E 224	Low pressure switch failed closed.	Check operation of low pressure switch to see if it is stuck closed on heat call longer than 150 seconds. Measure operating pressure (inches w.c.). Inspect vent and combustion air inducer for correct operation and restriction. Resumes normal operation after fault is cleared.
E 225	High pressure switch failed open.	Check pressure (inches w.c.) of high pressure switch closing on heat call. Measure operating pressure (inches w.c.). Inspect vent and combustion air inducer for correct operation and restriction. Resumes normal operation after fault is cleared.
E 226	High pressure switch failed closed.	Check operation of high pressure switch closing on heat call. Measure operating pressure (inches w.c.). Inspect vent and combustion air inducer for correct operation and restriction. Resumes normal operation after fault is cleared.
E 227	Low pressure switch open during trial for ignition or run mode.	Check pressure (inches w.c.) of low pressure switch closing on heat call. Measure operating pressure (inches w.c.). Inspect vent and combustion air inducer for correct operation and restriction. Resumes normal operation after fault is cleared.
E 228	Combustion air inducer calibration failure	Unable to perform pressure switch calibration. Check vent system and pressure switch wiring connections. Resumes normal operation after fault is cleared.
E 229	Ignition on High Fire - Information Only	Code is displayed if 1) low pressure switch fails to close, then furnace will switch to high speed inducer to close both low and high pressure switches, then furnace lights on high fire, or 2) if continuous fan is active, furnace lights on high fire for 60 seconds to improve heat exchanger warm up time.
E 240	Low flame current - Run mode.	Check micro-amperes of flame sensor using control diagnostics or field-installed mode. Clean or replace sensor. Measure voltage of neutral to ground to ensure good unit ground. Alert clears after current heat call has been completed.
E 241	Flame sensed out of sequence - Flame still present.	Shut off gas. Check for gas valve leak. Replace, if necessary. Alert clears when fault is recovered.
E 250	Limit switch circuit open.	Check for proper firing rate on furnace. Ensure there is no blockage in heater. Check for proper air flow. If limit not closed within 3 minutes, unit will go into 1-hour soft lockout. Resumes normal operation after fault is cleared.
E 252	Discharge air temperature too high (gas heat only).	Check temperature rise, air flow and input rate. Cleared when heat call is finished.
E 270	Soft lockout - Exceeded maximum number of retries. No flame current sensed.	Check for proper gas flow. Ensure that ignitor is lighting burner. Check flame sensor current. Clears when heat call finishes successfully.

TABLE 5 Continued

Code	Diagnostic Codes/Status of Equipment	Action Required to Clear and Recover
E 271	Soft lockout - Exceeded maximum number of retries. Last retry failed due to the pressure switch opening.	Check pressure (inches w.c.) of low pressure switch closing on heat call. Measure operating pressure (inches w.c.). Inspect vent and combustion air inducer for correct operation and restriction. Clears when heat call finishes successfully.
E 272	Soft lockout - Exceeded maximum number of recycles. Last recycle due to the pressure switch opening.	Check operation of low pressure switch to see if it is stuck closed on heat call. Check pressure (inches w.c.) of high pressure switch closing on heat call. Measure operating pressure (inches w.c.). Inspect vent and combustion air inducer for correct operation and restriction. Clears when heat call finishes successfully.
E 273	Soft lockout - Exceeded maximum number of recycles. Last recycle due to flame failure.	Check micro-amperes of flame sensor using control diagnostics or field-installed mode. Clean or replace sensor. Measure voltage of neutral to ground to ensure good unit ground. Clears when heat call finishes successfully.
E 274	Soft lockout - Exceeded maximum number of recycles. Last recycle failed due to the limit circuit opening or limit remained open longer than 3 minutes.	Shut down system. 1-hour soft lockout. Check firing rate and air flow. Check for blockage. Clears when heat call finishes successfully.
E 275	Soft lockout - Flame sensed out of sequence. Flame signal is gone.	Shut off gas. Check for gas valve leak. 1-hour soft lockout. Clears when flame has been proven stable.
E 276	Watchguard calibration failure.	Unable to perform pressure switch calibration. Check vent system and pressure switch wiring connections. 1-hour soft lockout. Clears when calibration has finished successfully.
E 290	Ignitor circuit fault - Failed ignitor or triggering circuitry.	Measure resistance of hot surface ignitor. Replace if open or not within specifications. 1-hour soft lockout. Clears when flame has been proven stable.
E 291	Heat air flow restricted below the minimum.	Check for dirty filter and air flow restriction. Check blower performance. 1-hour soft lockout. Cleared when heat call finishes successfully.
E 292	Indoor blower motor unable to start due to obstructed wheel, seized bearings.	Indoor blower motor unable to start (seized bearing, stuck wheel, etc.). Replace motor or wheel if assembly does not operate or meet performance standards. 1-hour soft lockout. Clears after circulator successfully starts.
E 294	Combustion air inducer over current.	Check combustion blower bearings, wiring and amps. Replace if does not operate or does not meet performance standards. Clears after inducer current is sensed to be in-range after the ignition following the soft lockout or reset.
E 295	Indoor blower motor temperature is too high.	Indoor blower motor over temperature (motor tripped on internal protector). Check motor bearings and amps. Replace if necessary. Cleared after blower demand is satisfied.
E 310	Discharge error temperature sensor failure. Only shown if shorted or out of range.	Compare outdoor sensor resistance to temperature/resistance charts in installation instructions. Replace sensor if necessary. Cleared in Communicating mode: 30 seconds after fault recovered. In Non-Communicating mode: Cleared after the current heat call is completed.
E 311	Heat rate reduced to match indoor blower air flow.	Warning Only. Furnace blower in cutback mode due to restricted airflow. Reduce firing rate every 60 seconds to match available CFM. Check filter and duct system. To clear, replace filter if needed or repair/add duct. 2-stage controls will reduce firing rate to 1 st stage. Clears when heat call finishes successfully.

TABLE 5 Continued

Code	Diagnostic Codes/Status of Equipment	Action Required to Clear and Recover
E 312	Restricted air flow in cooling or continuous fan mode is lower than cfm setting.	Warning Only. Restricted airflow - Indoor blower is running at a reduced CFM (Cutback Mode - The variable speed motor has pre-set speed and torque limiters to protect the motor from damage caused by operating outside of design parameters (0 to 0.8" W.C.. total external static pressure). Check filter and duct system. To clear, replace filter if needed or repair/add duct. Cleared after the current service demand is satisfied.
E 313	Indoor or outdoor unit capacity mismatch. Communication only.	Incorrect indoor/outdoor capacity code selected. Check for proper configuring in installation instructions. Alarm is just a warning. The system will operate, but might not meet efficiency and capacity parameters. Alarm will clear when commissioning is exited. Cleared after commissioning is complete.
E 331	Global network connection - Communication link problem.	For Future Use.
E 334	Relay "Y1" stuck on interated control.	Replace integrated control.
E 347	No 24 Volt output on Y1 of "integrated control" with non communicating outdoor unit.	Operation stopped. Y1 relay / Stage 1 failed. (Pilot relay contacts did not close or the relay coil did not energize; no input back to IFC chip). Critical Alert. Cleared after reset and Y1 input sensed.
E 348	No 24 Volt output on Y2 of "integrated control" with non?communicating outdoor unit.	Y2 relay / Stage 2 failed. (Pilot relay contacts did not close or the relay coil did not energize; no input back to IFC chip). Critical Alert. Cleared after reset and Y1 input sensed.
E 349	No 24 Volts between R & O on "integrated control" with non communicating outdoor unit (Dual fuel module required for heat pump application).	Configuration link R to O needs to be restored. Replace link or hard-wire. Applicable in non communicating mode. Critical Alert.
E 370	Interlock switch sensed open for 2 minutes.	Control sees the loss of 24VAC for 2 minutes .Terminate all services and wait for interlock switch to close. The alarm will clear when 24VAC is continuously sensed on DS terminal for a minimum of 10 seconds or on a power reset.
E 400	LSOM - Compressor internal overload tripped.	Thermostat demand Y1 is present; but, compressor is not running. Check power to outdoor unit. Clears the error after current is sensed in both RUN and START sensors for at least 2 seconds, or after service is removed, or after power reset.
E 401	LSOM Compressor long run cycle or low system pressure.	Compressor ran more than 18 hours to satisfy a single thermostat demand. Critical Alert. Clears the error after 30 consecutive normal run cycles or power reset. Also monitors low pressure switch trips.
E 402	LSOM - Outdoor unit system pressure trip.	Discharge or suction pressure out-of-limits, or compressor overloaded. Clears the error after 4 consecutive normal compressor run cycles.
E 403	LSOM - Compressor short-cycling. .(Running less than 4 minutes). Outdoor unit pressure trip	Compressor runs less than 3 minutes to satisfy a thermostat demand. Clears the error after 4 consecutive normal run cycles or power reset.
E 404	LSOM - Compressor rotor locked. Compressor short-cycling. (Running less than 4 minutes).	Compressor rotor locked up due to run capacitor short, bearings are seized, excessive liquid refrigerant, etc. Clears the error after 4 consecutive normal run cycles or after power reset.
E 405	LSOM - Compressor open circuit.	Compressor circuit open (due to power disconnection, open fuse, etc.) Clears the error after 1 normal compressor run cycle.

TABLE 5 Continued

Code	Diagnostic Codes/Status of Equipment	Action Required to Clear and Recover
E 406	LSOM - Compressor open start circuit.	Required amount of current is not passing through Start current transformer. Clears the error after current is sensed in START sensor, or after power reset.
E 407	LSOM - Compressor open run circuit.	Required amount of current is not passing through Run current transformer. Clears the error after current is sensed in RUN sensor, or 1 normal compressor run cycle, or after power reset.
E 408	LSOM - Compressor contactor is welded.	Compressor runs continuously. Clears the error after 1 normal compressor run cycle or after power reset.
E 409	LSOM - Compressor low voltage.	Secondary voltage is below 18VAC. After 10 minutes, operation is discontinued. Clears the code after voltage is higher than 20 VAC for 2 seconds or after power reset.

DIP Switch Settings

NOTE - All *icomfort*® settings are set at the *icomfort Wi-Fi*® thermostat. See *icomfort installation instruction*. In *icomfort communication system* all DIP switch and clippable link settings are ignored. For conventional thermostats proceed with DIP switch and clippable link settings as outlined in the following.

Heating Operation DIP Switch Settings

Switch 1 -- Thermostat Selection -- This unit may be used with either a single-stage or two-stage thermostat. The thermostat selection is made using a DIP switch which must be properly positioned for the particular application. The DIP switch is factory-positioned for use with a two-stage thermostat. If a single-stage thermostat is to be used, the DIP switch must be repositioned.

Select “OFF” for two-stage heating operation controlled by a two-stage heating thermostat (factory setting);

- b - Select “ON” for two-stage heating operation controlled by a single-stage heating thermostat. This setting provides a timed delay before second-stage heat is initiated.

Switch 2 -- Second Stage Delay (Used with Single-Stage Thermostat Only) -- This switch is used to determine the second stage on delay when a single-stage thermostat is being used. The switch is factory-set in the OFF position, which provides a 7-minute delay before second-stage heat is initiated. If the switch is toggled to the ON position, it will provide a 12-minute delay before second-stage heat is initiated. This switch is only activated when the thermostat selector jumper is positioned for SINGLE-stage thermostat use.

Switches 3 and 4 -- Blower-Off Delay -- The blower-on delay of 30 seconds is not adjustable. The blower-off delay (time that the blower operates after the heating demand has been satisfied) can be adjusted by moving switches 3 and 4 on the integrated control. The unit is shipped from the factory with a blower-off delay of 90 seconds. The blower

off delay affects comfort and is adjustable to satisfy individual applications. Adjust the blower off delay to achieve a supply air temperature between 90° and 110°F at the exact moment that the blower is de-energized. Longer off delay settings provide lower supply air temperatures; shorter settings provide higher supply air temperatures. Table 6 provides the blower off timings that will result from different switch settings.

**TABLE 6
Blower Off Delay Switch Settings**

Blower Off Delay (Seconds)	Switch 3	Switch 4
60	On	Off
90 (Factory)	Off	Off
120	Off	On
180	On	On

Indoor Blower Operation DIP Switch Settings

Switches 5 and 6 -- Cooling Mode Blower Speed -- The unit is shipped from the factory with the dip switches positioned for high speed (4) indoor blower motor operation during the cooling mode. Table 7 provides the cooling mode blower speeds that will result from different switch settings. Switches 5 and 6 set the blower cfm for second-stage cool. The integrated control automatically ramps down to 70% of the second-stage cfm for first-stage cfm. Refer to blower data tables for corresponding cfm values.

**TABLE 7
Cooling Mode Blower Speeds**

Speed	Switch 5	Switch 6
Low	On	On
Medium Low	Off	On
Medium High	On	Off
High (Factory)	Off	Off

Switches 7 and 8 -- Cooling Blower Speed Adjustment -- The unit is shipped from the factory with the dip switches positioned for NORMAL (no) adjustment. The dip switches may be positioned to adjust the blower speed by +10% or

-10% to better suit the application. Table 8 below provides blower speed adjustments that will result from different switch settings. Refer to blower data tables for corresponding cfm values.

TABLE 8
Cooling Blower Speed Adjustment

Adjustment	Switch 7	Switch 8
+10% (approx.)	On	Off
Factory Default	Off	Off
-10% (approx.)	Off	On

Switches 9 and 10 -- Cooling Mode Blower Speed Ramping -- Blower speed ramping may be used to enhance dehumidification performance. The switches are factory set at option A which has the greatest effect on dehumidification performance. Table 9 provides the cooling mode blower speed ramping options that will result from different switch settings. The cooling mode blower speed ramping options are detailed below.

NOTE - In heat pump mode blower operation defaults to option c.

TABLE 9
Cooling Mode Blower Speed Ramping

Ramping Option	Switch 9	Switch 10
A (Factory)	Off	Off
B	Off	On
C	On	Off
D	On	On

Ramping Option A (Factory Selection)

- Motor runs at 50% for 30 seconds.
- Motor then runs at 82% for approximately 7-1/2 minutes.
- If demand has not been satisfied after 7-1/2 minutes, motor runs at 100% until demand is satisfied.
- Once demand is met, motor runs at 50% for 30 seconds then ramps down to stop.

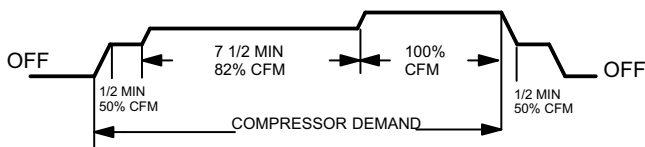

Ramping Option B

- Motor runs at 82% for approximately 7-1/2 minutes. If demand has not been satisfied after 7-1/2 minutes, motor runs at 100% until demand is satisfied.
- Once demand is met, motor ramps down to stop.

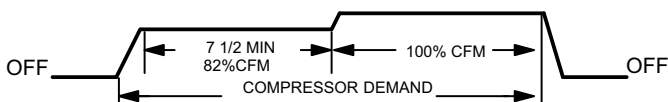

Ramping Option C

- Motor runs at 100% until demand is satisfied.
- Once demand is met, motor runs at 100% for 45 seconds then ramps down to stop.

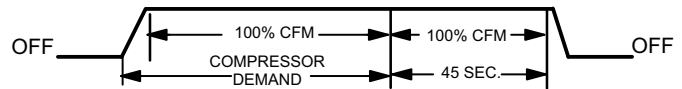

Ramping Option D

- Motor runs at 100% until demand is satisfied.
- Once demand is met, motor ramps down to stop.

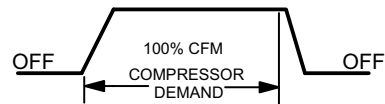

Switches 11, 12 and 13 -- Heating Mode Blower Speed

The switches are factory set to the OFF position which provides factory default heat speed. Refer to table 10 for switches 11, 12 and 13 that provided the corresponding increases or decrease to both high and low heat demand.

TABLE 10
Heating Mode Blower Speeds

Heat Speed	Switch 11	Switch 12	Switch 13
Increase 24%	On	On	On
Increase 18%	On	On	Off
Increase 12%	On	Off	On
Increase 6%	On	Off	Off
Factory Default	Off	Off	Off
Decrease 6%	Off	Off	On
Decrease 12%	Off	On	Off
Decrease 18%	Off	On	On

Switches 14 and 15 -- Continuous Blower Speed

Table 11 provides continuous blower speed adjustments that will result from different switch settings.

TABLE 11
Continuous Blower Speed

Continuous Blower Speed	Switch 14	Switch 15
28% of High Cool Speed	Off	On
38% of High Cool Speed (Factory)	Off	Off
70% of High Cool Speed	On	Off
100% of High Cool Speed	On	On

On-Board Links

Note: In *icomfort*® systems with a conventional outdoor unit (non-communicating), the on-board clippable links must be set to properly configure the system.

!WARNING

Carefully review all configuration information provided. Failure to properly set DIP switches, jumpers and on-board links can result in improper operation!

On-Board Link W914 Dehum or Harmony (R to DS)

On-board link W914, is a clippable connection between terminals R and DS on the integrated control. W914 must be cut when the furnace is installed with either the Harmony III™ zone control or a thermostat which features humidity control. If the link is left intact the PMW signal from the Harmony III control will be blocked and also lead to control

damage. Refer to table 12 for operation sequence in applications including SL297UHNV, a thermostat which features humidity control and a single-speed outdoor unit. Table 13 gives the operation sequence in applications with a two-speed outdoor unit.

On-Board Link W951 Heat Pump (R to O)

On-board link W951 is a clippable connection between terminals R and O on the integrated control. W951 must be cut when the furnace is installed in applications which include a heat pump unit and a thermostat which features dual fuel use. If the link is left intact, terminal “O” will remain energized eliminating the HEAT MODE in the heat pump.

On-Board Link W915 2 Stage Compr (Y1 to Y2)

On-board link W915 is a clippable connection between terminals Y1 and Y2 on the integrated control. W915 must be cut if two-stage cooling will be used. If the Y1 to Y2 link is not cut the outdoor unit will operate in second-stage cooling only.

**TABLE 12
OPERATING SEQUENCE**

SL297UHNV, Non-Communicating Thermostat with Humidity Control Feature and Single-Speed Outdoor Unit

OPERATING SEQUENCE		SYSTEM DEMAND						SYSTEM RESPONSE		
System Condition	Step	Thermostat Demand				Relative Humidity		Compressor	Blower CFM (COOL)	Comments
		Y1	O	G	W 1	Status	D			
<i>NO CALL FOR DEHUMIDIFICATION</i>										
Normal Operation	1	On	On	On		Acceptable	24 VAC	High	100%	Compressor and indoor blower follow thermostat demand
<i>BASIC MODE (only active on a Y1 thermostat demand)</i>										
Normal Operation	1	On	On	On		Acceptable	24 VAC	High	100%	Thermostat energizes Y1 and de-energizes D on a call for de-humidification
Dehumidification Call	2	On	On	On		Demand	0 VAC	High	70%*	
<i>PRECISION MODE (operates independent of a Y1 thermostat demand)</i>										
Normal Operation	1	On	On	On		Acceptable	24 VAC	High	100%	Dehumidification mode begins when humidity is greater than set point
Dehumidification call	2	On	On	On		Demand	0 VAC	High	70%*	
Dehumidification call ONLY	1	On	On	On		Demand	0 VAC	High	70%*	Thermostat will try to maintain room humidity setpoint by allowing the room space to maintain a cooler room thermostat setpoint**
Jumpers at indoor unit with a single stage outdoor unit With Condensing unit - Cut W914 (R to DS) on SureLight® control With Heat Pump - Cut W914 (R to DS) & W951 (R to O) on SureLight® control										

Use Dave Lennox ComfortSense® 7500 thermostat Y2081 4 heat / 2 cool for this application

*Dehumidification blower speed is 70% of COOL speed for all units .

**In Precision mode, ComfortSense® 7000 thermostat will maintain room temperature up to 2 °F (1.2°C) cooler than room setting.

**TABLE 13
OPERATING SEQUENCE**

SL297UHNV, Non-Communicating Thermostat with Humidity Control Feature and Two-Speed Outdoor Unit

OPERATING SEQUENCE		SYSTEM DEMAND								SYSTEM RESPONSE		
System Condition	Step	Thermostat Demand						Relative Humidity		Compressor	Blower CFM (COOL)	Comments
		Y1	Y2	O	G	W1	W2	Status	D			
NO CALL FOR DEHUMIDIFICATION												
Normal Operation - Y1	1	On		On	On			Acceptable	24 VAC	Low	70%*	Compressor and indoor blower follow thermostat demand
Normal Operation - Y2	2	On	On	On	On			Acceptable	24 VAC	High	100%	
ROOM THERMOSTAT CALLS FOR FIRST STAGE COOLING												
<i>BASIC MODE (only active on a Y1 thermostat demand)</i>												
Normal Operation	1	On		On	On			Acceptable	24 VAC	Low	70%*	Thermostat energizes Y2 and de-energizes D on a call for de-humidification
Dehumidification Call	2	On	On	On	On			Demand	0 VAC	High	70%**	
<i>PRECISION MODE (operates independent of a Y1 thermostat demand)</i>												
Normal Operation	1	On		On	On			Acceptable	24 VAC	Low	70%*	Dehumidification mode begins when humidity is greater than set point
Dehumidification call	2	On	On	On	On			Demand	0 VAC	High	70%**	
Dehumidification call ONLY	1	On	On	On	On			Demand	0 VAC	High	70%**	Thermostat will try to maintain room humidity setpoint by allowing the room space to maintain a cooler room thermostat setpoint***
ROOM THERMOSTAT CALLS FOR FIRST AND SECOND STAGE COOLING												
<i>BASIC MODE (only active on a Y1 thermostat demand)</i>												
Normal Operation	1	On	On	On	On			Acceptable	24 VAC	High	100%	Thermostat energizes Y2 and de-energizes D on a call for de-humidification
Dehumidification Call	2	On	On	On	On			Demand	0 VAC	High	70%**	
<i>PRECISION MODE (operates independent of a Y1 thermostat demand)</i>												
Normal Operation	1	On		On	On			Acceptable	24 VAC	Low	70%*	Dehumidification mode begins when humidity is greater than set point
Dehumidification call	2	On	On	On	On			Demand	0 VAC	High	70%**	
Dehumidification call ONLY	1	On	On	On	On			Demand	0 VAC	High	70%**	Thermostat will try to maintain room humidity setpoint by allowing the room space to maintain a cooler room thermostat setpoint***
	Jumpers at indoor unit with a two stage outdoor unit Cut factory jumper from Y1 to Y2 or cut W915 (Y1 to Y2) With Condensing unit - Cut W914 (R to DS) on SureLight® control With Heat Pump - Cut W914 (R to DS) & W951 (R to O) on SureLight® control											Thermostat will try to maintain room humidity setpoint by allowing the room space to maintain a cooler room thermostat setpoint***

Use Dave Lennox ComfortSense® 7500 thermostat Y2081 4 heat / 2 cool for this application.

*Normal operation first stage cooling blower speed is 70% COOL speed.

**Dehumidification blower speed is, reduced to 70% of COOL.

***In Precision mode, ComfortSense® 7500 thermostat will maintain room temperature up to 2 °F (1.2°C) cooler than room setting.

B- Indoor Blower Motor

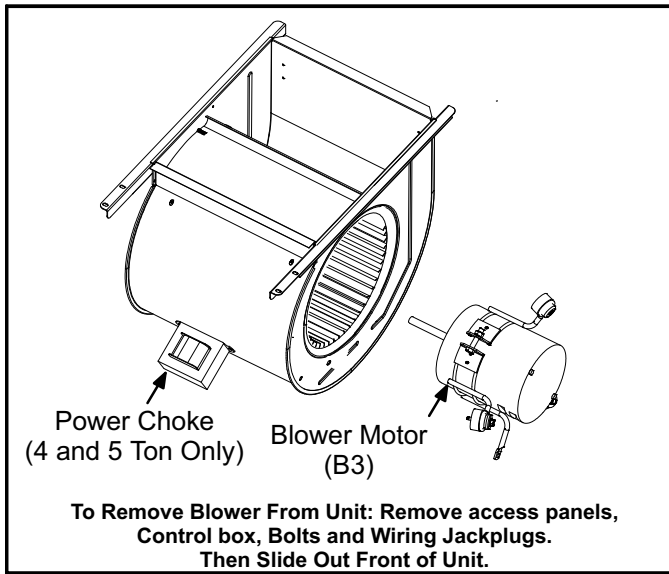

FIGURE 6

⚠ WARNING

During blower operation, the ECM motor emits energy that may interfere with pacemaker operation. Interference is reduced by both the sheet metal cabinet and distance.

The motor communicates with the integrated control via a 2-way serial connection. The motor receives all necessary functional parameters from the integrated control and does not rely on a factory program like traditional variable speed motors. SL297UHNV units use a three-phase, electronically controlled D.C. brushless motor (controller converts single phase a.c. to three phase D.C.), with a permanent-magnet-type rotor (figure 7). Because this motor has a permanent magnet rotor it does not need brushes like conventional D.C. motors.

The stator windings are split into three poles which are electrically connected to the controller. This arrangement allows motor windings to turn on and off in sequence by the controller.

⚠ IMPORTANT

Earlier ECM motors used on other Lennox furnace models are not interchangeable with motors used on the SL297UH furnace line.

A solid-state controller is permanently attached to the motor. The controller is primarily an A.C. to D.C. converter. Converted D.C. power is used to drive the motor. The controller contains a microprocessor which monitors varying conditions inside the motor (such as motor workload).

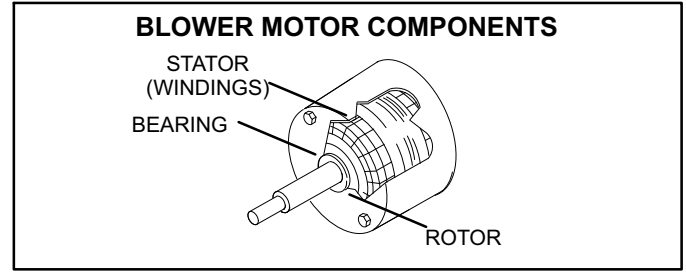

FIGURE 7

The controller uses sensing devices to sense what position the rotor is in at any given time. By sensing the position of the rotor and then switching the motor windings on and off in sequence, the rotor shaft turns the blower.

All SL297UHNV blower motors use single phase power. An external run capacitor is not used. The motor uses permanently lubricated ball-type bearings.

Internal Operation

The motor is controlled via serial communication between the integrated control on the furnace and the controller attached to the motor shell. The messages sent back and forth between the two controls serve to communicate rotational direction, demand, motor size, current draw, torque, and rpm, among other variables.

Motor rpm is continually adjusted internally to maintain constant static pressure against the blower wheel. The controller monitors the static work load on the motor and motor amp-draw to determine the amount of rpm adjustment. Blower rpm may be adjusted any amount in order to maintain a constant cfm as shown in Blower Ratings Tables. The cfm remains relatively stable over a broad range of static pressure. Since the blower constantly adjusts rpm to maintain a specified cfm, motor rpm is not rated. Hence, the terms "cool speed", "heat speed" or "speed tap" in this manual, on the unit wiring diagram and on blower B3, refer to blower cfm regardless of motor rpm.

Initial Power Up

When line voltage is applied to B3, there will be a large inrush of power lasting less than 1/4 second. This inrush charges a bank of DC filter capacitors inside the controller. If the disconnect switch is bounced when the disconnect is closed, the disconnect contacts may become welded. Try not to bounce the disconnect switch when applying power to the unit.

Motor Start-Up

When B3 begins start-up, the motor gently vibrates back and forth for a moment. This is normal. During this time the electronic controller is determining the exact position of the rotor. Once the motor begins turning, the controller slowly eases the motor up to speed (this is called "soft-start"). The motor may take as long as 10-15 seconds to reach full speed. If the motor does not reach 200 rpm within 13 seconds, the motor shuts down. Then the motor will immediately attempt a restart. The shutdown feature provides protection in case of a frozen bearing or blocked blower wheel. The motor may attempt to start eight times. If the motor does not start after the eighth try, the controller locks out. Reset controller by momentarily turning off power to unit.

The DC filter capacitors inside the controller are connected electrically to the motor supply wires. The capacitors take approximately 5 minutes to discharge when the disconnect is opened. For this reason it is necessary to wait at least 5 minutes after turning off power to the unit before attempting to service motor.

⚠ DANGER	
	Disconnect power from unit and wait at least five minutes to allow capacitors to discharge before attempting to service motor. Failure to wait may cause personal injury or death.

Power Choke (L13)

A choke coil is used on SL297UHNV 4 and 5 ton units equipped with 1 hp motors. The choke is located on the blower housing and is used to suppress transient current spikes.

Troubleshooting Motor Operation

To verify motor operation see steps below and figures 8 and 9.

- 1- Remove J48 (5 pin power plug) from P48 on the motor.
- 2- With the power on at the furnace and door switch depressed, use a test meter to verify 120V between pins 4 and 5 on J48.
- 3- Reconnect J48 to P48 on the motor.
- 4- Remove J49 (4 pin low voltage connector) from P49 on the motor.
- 5- Using test jumpers, apply 24V to pins 3 and 4 on P49 on the motor.

Note: Do not apply 24V to pins 2 and 4 on P49. Doing so will cause permanent damage to the motor.

- 6- Motor should run at 75%.
- 7- Test is complete. Remove jumpers and reconnect plugs.

Another option is to use the TECMate PRO motor tester with the 16 to 4 pin adaptor. The use of the TECMate PRO isolates the motor from the integrated control. Follow the instructions provided with the kit. If the motor runs do not replace.

BLOWER B3 HARNESS CONNECTORS

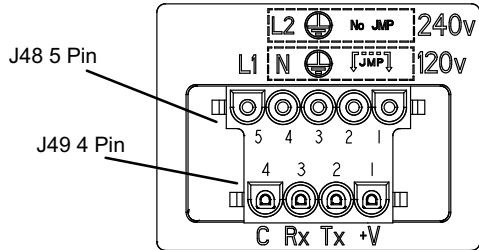
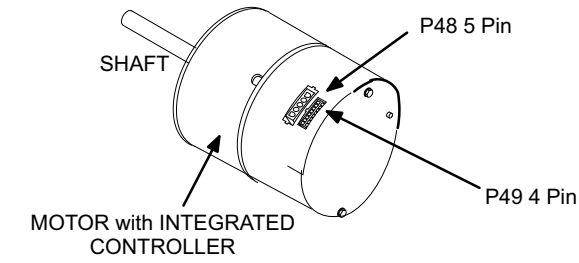

J49 4 Pin Control Connector	
PIN	DESCRIPTION
1	12V INPUT
2	SERIAL DATA OUTPUT
3	SERIAL DATA INPUT
4	COMMON

J48 5 Pin Line Voltage Connector	
PIN	DESCRIPTION
1	JUMPER PIN 1 TO PIN 2 FOR 120VAC LINE INPUT ONLY ***
2	
3	CHASSIS GROUND
4	AC LINE
5	AC LINE

FIGURE 8

BLOWER B3 HARNESS CONNECTORS

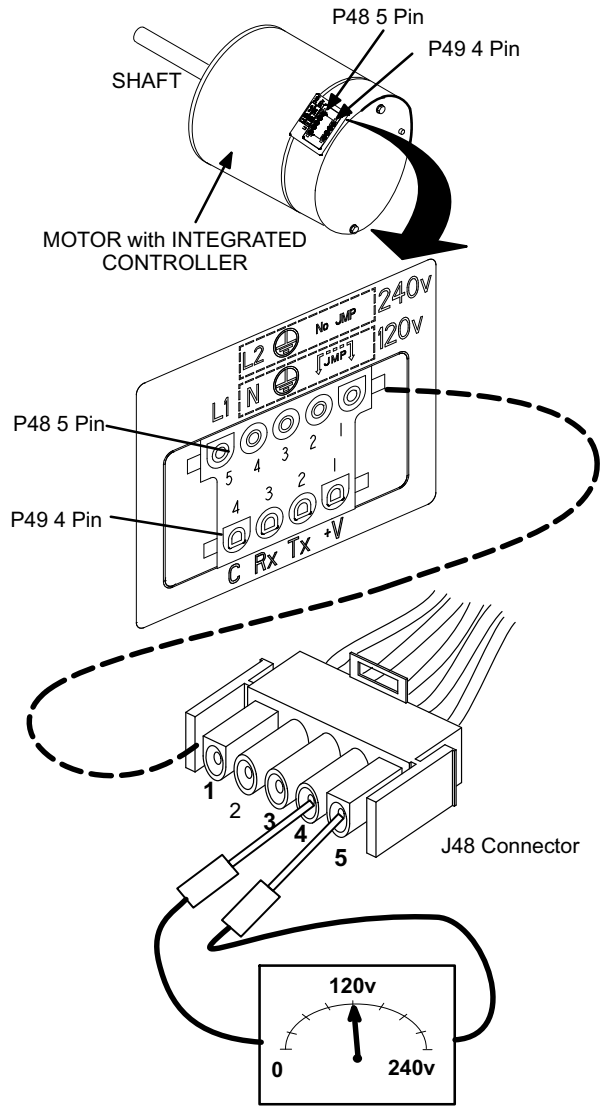

J48 Connector installed on motor

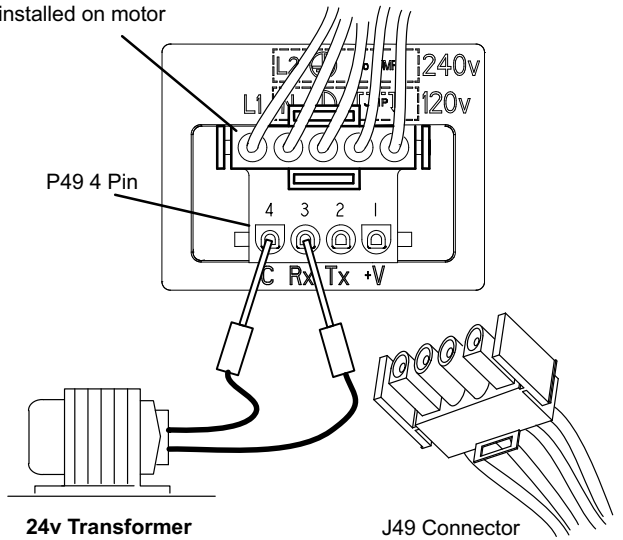

FIGURE 9

Troubleshooting Motor Windings

Ensure that motor windings are not damaged by performing the following tests:

NOTE - If your ohm meter is not an auto-ranging type, set it to the highest ohm scale (100k ohms or greater) before performing tests.

TABLE 14
Ohm Meter Range

Scale	Measurement Range	
	in words	ohms
2M	two megohm -- two million ohms	0-2,000,000
200k	two hundred kilohm -- two hundred thousand ohms	0-200,000
20k	twenty kilohm -- twenty thousand ohms	0-20,000
2k	two kilohm -- two thousand ohms	0-2,000
200	two hundred ohm	0-200

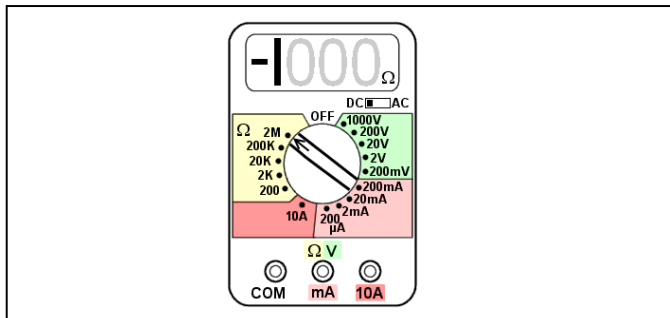

FIGURE 10

TEST A

Measure the resistance between each of the three motor leads (3-pin plug) and the unpainted part of the end shield.

If the winding resistance to ground is <100k ohms, replace the motor and control module. If the resistance to ground is >100k, the motor windings are fine. Proceed to Test B.

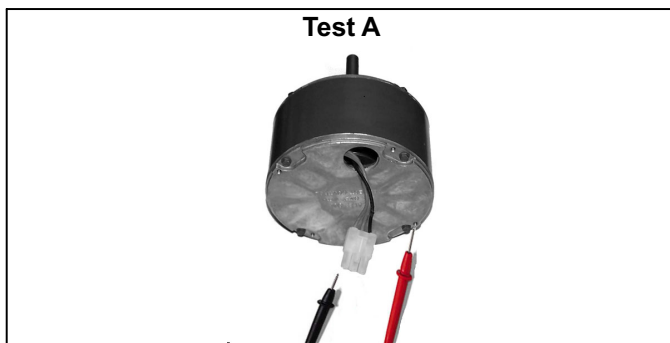

FIGURE 11

TEST B

Use an ohmmeter to measure the motor phase-to-phase resistance by checking these combinations of the the 3-pin motor plug. For the purpose of this test, start at either end of the connector as lead 1.

1 - The lead-to-lead resistance across any two leads should be less than 20 ohms.

2 - Each lead-to-lead resistance should be the same.

If the measured resistance is greater than 20 ohms, replace the motor and control module.

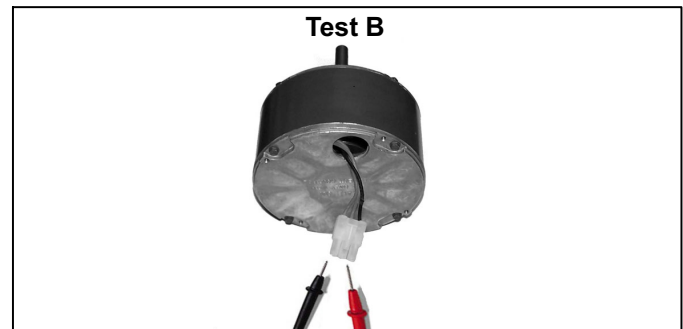

FIGURE 12

C- Heating Components

1. Ignitor

The SureLight[®] ignitor is made of durable silicon nitride. Ignitor longevity is enhanced by controlling voltage to the ignitor. The integrated control provides a regulated 120 volts to the ignitor for a consistent ignition and long ignitor life. Ohm value should be 39 to 70. The ignitor is located on the bottom of the air gas plenum (figure 13). See figure 14 for ignitor check out.

NOTE - The SL297UHNV furnace contains electronic components that are polarity sensitive. Make sure that the furnace is wired correctly and is properly grounded.

2. Flame Sensor

A flame sensor is located on the bottom of the air gas plenum. See Figure 13. The sensor can be removed for service without removing the the burner. During operation, flame is sensed by current passed through the flame and sensing electrode. The SureLight control allows the gas valve to remain open as long as flame signal is sensed. To check flame sense signal use the push-button found on the integrated control and go to Field Test Mode. The menu will display the flame signal. See Table 15 for flame signal.

TABLE 15
Flame Signal in Microamps

Normal	Low	Drop Out
2.6 or greater	2.5 or less	1.1

3. Gas Valve

The valve (figure 44) is internally redundant to assure safety shut-off. If the gas valve must be replaced, the same type valve must be used.

24VAC terminals and gas control knob are located on the valve. A wire harness connects the terminals from the gas valve to the electronic ignition control. 24V applied to the terminals energizes the valve.

Inlet and outlet pressure taps are located on the valve. A regulator adjustment screw is located on the valve.

4. Flame Rollout Switch (S47)

Flame rollout switch is a high temperature limit located on the front of the intake air assembly.ner box, one on each side.- See figure 13. The limit is a N.C. SPST auto-reset limit. When S47 senses rollout, the circuit breaks and the ignition control immediately stops ignition and closes the gas valve. Rollout can be caused by a blocked heat exchanger, flue or lack of combustion air.

5. Burner and Orifice

Burners are factory set and require no adjustment. Always operate the unit with air gas plenum in place. The burner has one orifice located between the gas valve and the air intake assembly (figure13). To check or replace the orifice remove

the black iron inlet pipe from the gas valve then remove the four screws securing the gas valve to the intake air pipe. The orifice is located in the orifice housing. The burner uses an orifice (see table 16) that is precisely matched to the burner input. The burner can be removed for service. If burner has been removed, it is critical to replace all gaskets.

TABLE 16
Nat Orifice Size

Unit Input	Orifice Size (0 - 4500 ft)
040	0.0472
060	0.0595
080	0.0689

6. Primary Limit Control (S10)

The primary limit (S10) is located in the heating vestibule panel. When excess heat is sensed in the heat exchanger, the limit will open. If the limit is open, the furnace control energizes the supply air blower and closes the gas valve. The limit automatically resets when unit temperature returns to normal. The switch must reset within three minutes or the SureLight control will go into Watch guard for one hour. The switch is factory set and cannot be adjusted. The switch may have a different set point for each unit model number. See Lennox Repair Parts Handbook if limit switch must be replaced,

SL297UHNV HEATING COMPONENTS

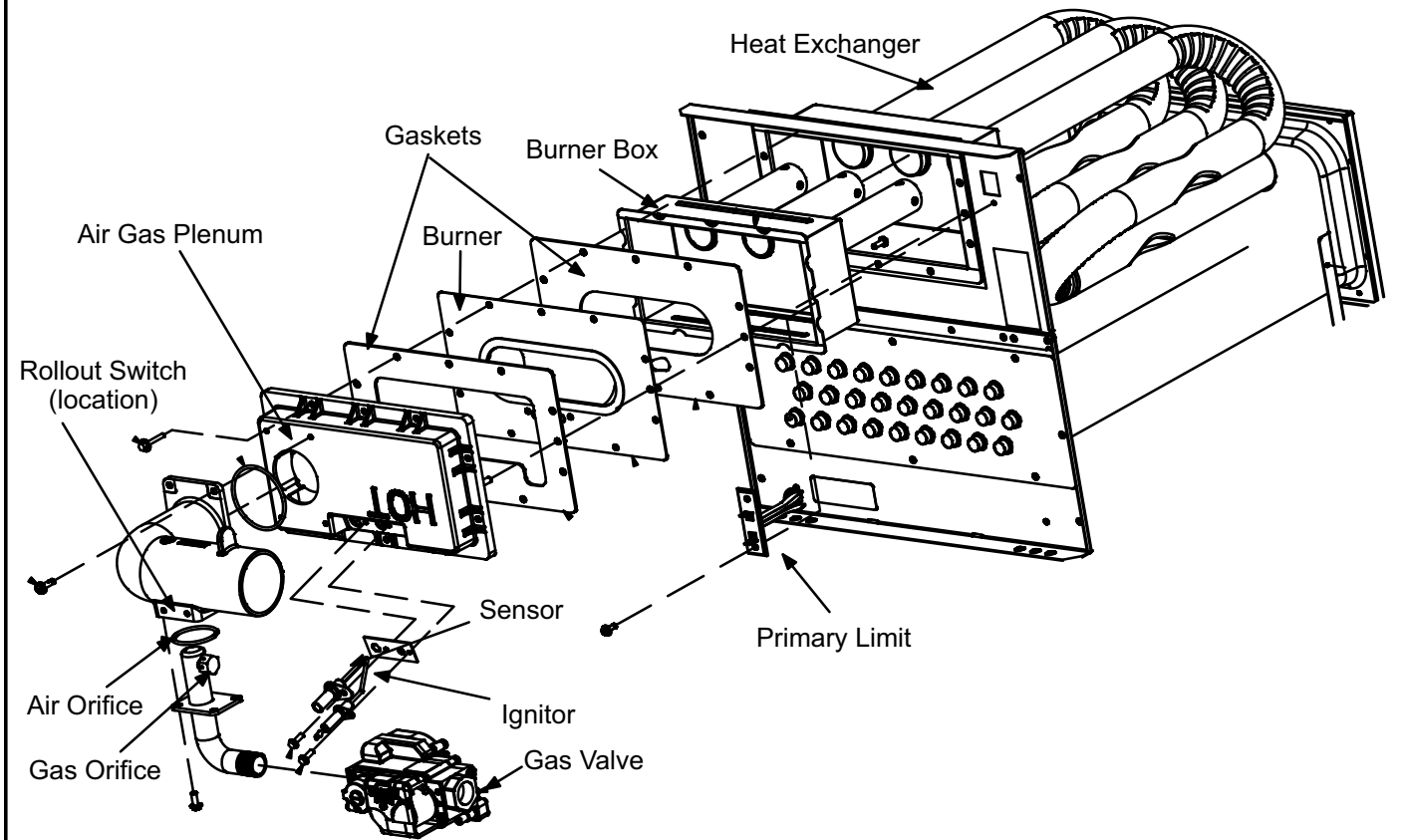

FIGURE 13

SL297UHNV Ignitor Check

Test 1

Check ignitor circuit for correct resistance.

Remove 5-pin plug from control.
Check ohms reading across terminals 1 and 5.
Reading should be between 39 and 70 ohms. If value is correct, this is the only test needed.
If the reading on the meter is not correct, (0 or infinity) then a second test is needed.

Meter
(set to ohms)

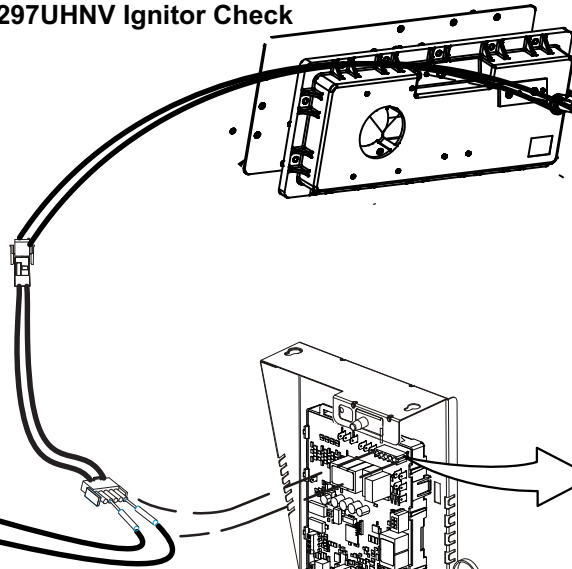
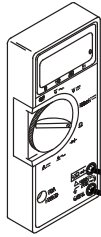

Integrated Control Detail

Test 2

Check ignitor for correct resistance.

Separate the 2-pin jack-plug near the manifold and check resistance of ignitor at the plug. Reading should be between 39 and 70 ohms. If the reading is correct, then the problem is with the wiring between the jack-plug and the control. If reading is not correct, the issue is the ignitor.

Meter
(set to ohms)

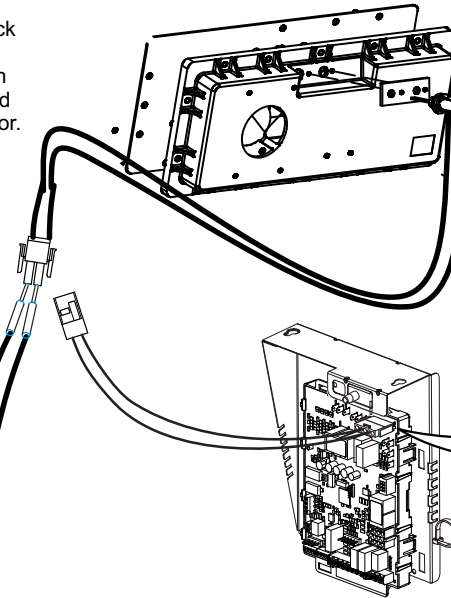
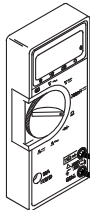

Integrated Control Detail

Test 3

Check ignitor for correct voltage

Insert meter probes into terminals 1 and 5 (use small diameter probes in order not to damage plug).
Check voltage during 20 second ignitor warm up period.
Voltage should read 120 volts \pm 10%. If voltage reads below these values, check for correct supply voltage to furnace.

Meter
(set to AC volts)

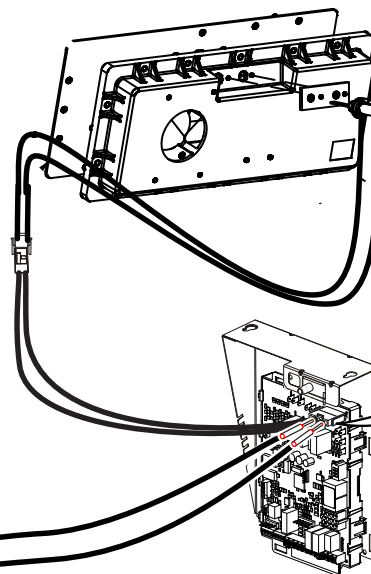
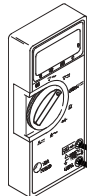

Integrated Control Detail

FIGURE 14

7. Combustion Air Inducer (B6)

All SL297UHNV units use a two-stage combustion air inducer (figure 15) to move air through the burners and heat exchanger during heating operation. The blower uses a 120VAC motor. The motor operates during all heating operation and is controlled by integrated control control A92. The inducer also operates for 15 seconds before burner ignition (pre-purge) and for 5 seconds after the gas valve closes (post-purge). The inducer operates on low speed during first-stage heat, then switches to high speed for second stage heat.

8. Combustion Air Inducer Prove Switch (S18)

SL297UHNV series units are equipped with a dual combustion air proving switch (first and second stage) located on the combustion air inducer housing. See figures 15 and 16. The switch is connected to the combustion air inducer housing by means of a flexible silicone hose. It monitors negative air pressure in the combustion air inducer housing.

The switches are a single-pole single-throw proving switch electrically connected to the integrated control. The purpose of the switch is to prevent burner operation if the combustion air inducer is not operating or if the flue becomes obstructed.

On heat demand (first or second stage) the switch senses that the combustion air inducer is operating. It closes a circuit to the integrated control when pressure inside the combustion air inducer decreases to a certain set point.

Set points vary depending on unit size. See table 17. The pressure sensed by the switch is negative relative to atmospheric pressure. If the flue becomes obstructed during operation, the switch senses a loss of negative pressure (pressure becomes more equal with atmospheric pressure) and opens the circuit to the furnace control and gas valve. A bleed port on the switch allows relatively dry air in the vestibule to purge switch tubing, to prevent condensate build up.

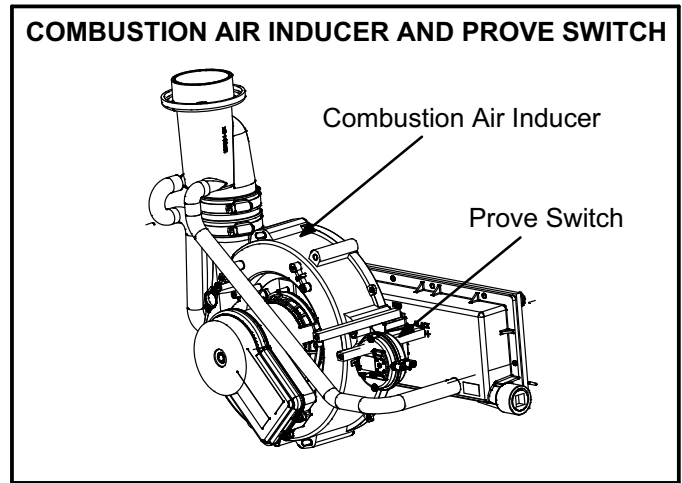

FIGURE 15

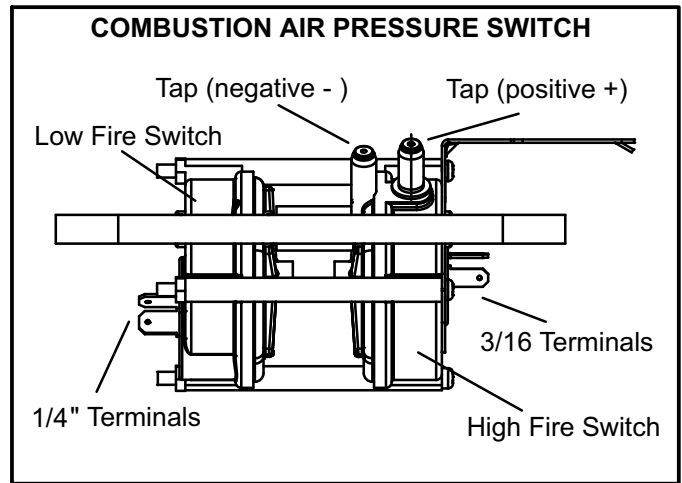

FIGURE 16

NOTE - The switch is factory set and is not field adjustable. It is a safety shut-down control in the furnace and must not be by-passed for any reason. If switch is closed or by-passed, the control will not initiate ignition at start up.

TABLE 17 0- 4500'

Unit	Set Point Low Heat	Set Point High Heat
-040	0.15"	0.50"
-060		
-080		

II-PLACEMENT AND INSTALLATION

All pipe, fittings, primer and solvent cement must conform with American National Standard Institute and the American Society for Testing and Materials (ANSI/ASTM) standards. The solvent shall be free flowing and contain no lumps, undissolved particles or any foreign matter that adversely affects the joint strength or chemical resistance of the cement. The cement shall show no gelation, stratification, or separation that cannot be removed by stirring. Refer to the table 18 below for approved piping and fitting materials.

**TABLE 18
PIPING AND FITTINGS SPECIFICATIONS**

Schedule 40 PVC (Pipe)	D1785
Schedule 40 PVC (Cellular Core Pipe)	F891
Schedule 40 PVC (Fittings)	D2466
Schedule 40 CPVC (Pipe)	F441
Schedule 40 CPVC (Fittings)	F438
SDR-21 PVC or SDR-26 PVC (Pipe)	D2241
SDR-21 CPVC or SDR-26 CPVC (Pipe)	F442
Schedule 40 ABS Cellular Core DWV (Pipe)	F628
Schedule 40 ABS (Pipe)	D1527
Schedule 40 ABS (Fittings)	D2468
ABS-DWV (Drain Waste & Vent) (Pipe & Fittings)	D2661
PVC-DWV (Drain Waste & Vent) Pipe & Fittings)	D2665
PRIMER & SOLVENT CEMENT	ASTM SPECIFICATION
PVC & CPVC Primer	F656
PVC Solvent Cement	D2564
CPVC Solvent Cement	F493
ABS Solvent Cement	D2235
PVC/CPVC/ABS All Purpose Cement For Fittings & Pipe of the same material	D2564, D2235, F493
ABS to PVC or CPVC Transition Solvent Cement	D3138
CANADA PIPE & FITTING & SOLVENT CEMENT	MARKING
PVC & CPVC Pipe and Fittings	ULCS636
PVC & CPVC Solvent Cement	
ABS to PVC or CPVC Transition Cement	
POLYPROPYLENE VENTING SYSTEM	ULC-S636
PolyPro® by Duravent	ULC-S636
InnoFlue® by Centrotherm	ULC-S636
UL 1738 CERTIFIED GAS VENTING SYSTEM	
IPEX System1738 Schedule 40 PVC Pipes and Fittings	UL1738
IPEX System PVC FGV Cement & Primer	

⚠ IMPORTANT

SL297UHNV exhaust and intake connections are made of PVC. Use PVC primer and solvent cement when using PVC vent pipe. When using ABS vent pipe, use transitional solvent cement to make connections to the PVC fittings in the unit.

⚠ CAUTION

Solvent cements for plastic pipe are flammable liquids and should be kept away from all sources of ignition. Do not use excessive amounts of solvent cement when making joints. Good ventilation should be maintained to reduce fire hazard and to minimize breathing of solvent vapors. Avoid contact of cement with skin and eyes.

Use PVC primer and solvent cement or ABS solvent cement meeting ASTM specifications, refer to Table 18. As an alternate, use all purpose cement, to bond ABS, PVC, or CPVC pipe when using fittings and pipe made of the same materials. Use transition solvent cement when bonding ABS to either PVC or CPVC.

Low temperature solvent cement is recommended during cooler weather. Metal or plastic strapping may be used for vent pipe hangers. Uniformly apply a liberal coat of PVC primer for PVC or use a clean dry cloth for ABS to clean inside socket surface of fitting and male end of pipe to depth of fitting socket.

Canadian Applications Only - Pipe, fittings, primer and solvent cement used to vent (exhaust) this appliance must be certified to ULC S636 and supplied by a single manufacturer as part of an approved vent (exhaust) system. In addition, the first three feet of vent pipe from the furnace flue collar must be accessible for inspection.

NOTE - The intake coupling on the furnace is ABS material. Use transitional solvent to make connections to PVC pipe.

NOTE - Exhaust coupling must be installed with provided appliance adapter. See figure 19.

**TABLE 19
OUTDOOR TERMINATION USAGE***

Input Size	Vent Pipe Dia. in.	STANDARD					CONCENTRIC		
		Flush-Mount Kit	Wall Kit		Wall Ring Kit	Field Fabricated	1-1/2 inch	2 inch	3 inch
			2 inch	3 inch	2 inch				
		51W11 (US) 51W12 (CA)	22G44 (US) 430G28 (CA)	44J40 (US) 481J20 (CA)	15F74		71M80 (US) 444W92 (CA)	69M29 (US) 444W92 (CA)	60L46 (US) 444W93 (CA)
040	2	³ YES	YES	¹ YES	¹ YES	⁵ YES	² YES		
	3	³ YES	YES	¹ YES	¹ YES	⁵ YES	² YES		
060	2	³ YES	YES	¹ YES	¹ YES	⁵ YES	² YES		
	3	³ YES	YES	¹ YES	¹ YES	⁵ YES	² YES		
080	2	³ YES		YES	YES	⁵ YES		YES	YES
	3	³ YES		YES	YES	⁵ YES		YES	YES

NOTE - Standard Terminations do not include any vent pipe or elbows external to the structure. Any vent pipe or elbows external to the structure must be included in total vent length calculations. See vent length tables.

** Kits must be properly installed according to kit instructions.*

¹Requires field-provided outdoor 1-1/2" exhaust accelerator.

²Concentric kits 71M80 and 44W92 include 1-1/2" outdoor accelerator, when used with 040 and 060 input models.

³Flush mount kits 51W11 and 51W12 includes 1-1/2 in. outdoor exhaust accelerator, required when used with 040, 060 and 080 input models.

⁴Termination kits 30G28, 44W92, 44W93 and 81J20 are certified to ULC S636 for use in Canada only.

⁵See table 24 for vent accelerator requirements.

Joint Cementing Procedure

All cementing of joints should be done according to the specifications outlined in ASTM D 2855.

⚠ DANGER

DANGER OF EXPLOSION!

Fumes from PVC glue may ignite during system check. Allow fumes to dissipate for at least 5 minutes before placing unit into operation.

- 1 - Measure and cut vent pipe to desired length.
- 2 - Debur and chamfer end of pipe, removing any ridges or rough edges. If end is not chamfered, edge of pipe may remove cement from fitting socket and result in a leaking joint.
NOTE - Check the inside of vent pipe thoroughly for any obstruction that may alter furnace operation.
- 3 - Clean and dry surfaces to be joined.
- 4 - Test fit joint and mark depth of fitting on outside of pipe.
- 5 - Uniformly apply a liberal coat of PVC primer for PVC or use a clean dry cloth for ABS to clean inside socket surface of fitting and male end of pipe to depth of fitting socket.

NOTE - Time is critical at this stage. Do not allow primer to dry before applying cement.

- 6 - Promptly apply solvent cement to end of pipe and inside socket surface of fitting. Cement should be applied lightly but uniformly to inside of socket. Take care to keep excess cement out of socket. Apply second coat to end of pipe.
- 7 - Immediately after applying last coat of cement to pipe, and while both inside socket surface and end of pipe are wet with cement, forcefully insert end of pipe into socket until it bottoms out. Turn PVC pipe 1/4 turn during assembly (but not after pipe is fully inserted) to distribute cement evenly. DO NOT turn ABS or cellular core pipe.
NOTE - Assembly should be completed within 20 seconds after last application of cement. Hammer blows should not be used when inserting pipe.
- 8 - After assembly, wipe excess cement from pipe at end of fitting socket. A properly made joint will show a bead around its entire perimeter. Any gaps may indicate an improper assembly due to insufficient solvent.
- 9 - Handle joints carefully until completely set.

Venting Practices

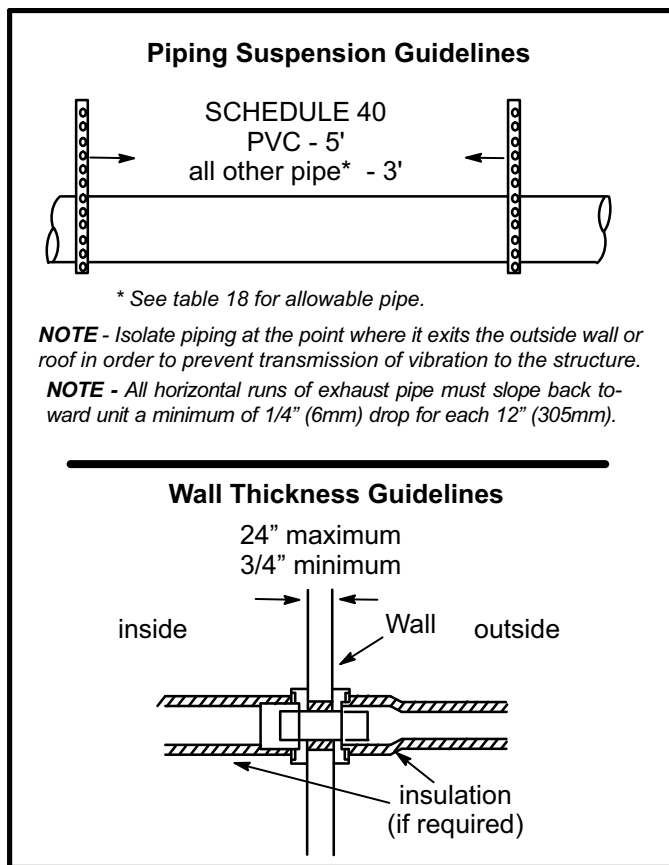

FIGURE 17

9. In areas where piping penetrates joists or interior walls, hole must be large enough to allow clearance on all sides of pipe through center of hole using a hanger.
10. When furnace is installed in a residence where unit is shut down for an extended period of time, such as a vacation home, make provisions for draining condensate collection trap and lines.

Removal of the Furnace from Common Vent

In the event that an existing furnace is removed from a venting system commonly run with separate gas appliances, the venting system is likely to be too large to properly vent the remaining attached appliances.

Conduct the following test while each appliance is operating and the other appliances (which are not operating) remain connected to the common venting system. If the venting system has been installed improperly, you **must** correct the system as indicated in the general venting requirements section.

⚠ WARNING

CARBON MONOXIDE POISONING HAZARD

Failure to follow the steps outlined below for each appliance connected to the venting system being placed into operation could result in carbon monoxide poisoning or death.

The following steps shall be followed for each appliance connected to the venting system being placed into operation, while all other appliances connected to the venting system are not in operation:

- 1 - Seal any unused openings in the common venting system.
- 2 - Inspect the venting system for proper size and horizontal pitch. Determine that there is no blockage, restriction, leakage, corrosion, or other deficiencies which could cause an unsafe condition.
- 3 - Close all building doors and windows and all doors between the space in which the appliances remaining connected to the common venting system are located and other spaces of the building. Turn on clothes dryers and any appliances not connected to the common venting system. Turn on any exhaust fans, such as range hoods and bathroom exhausts, so they will operate at maximum speed. Do not operate a summer exhaust fan. Close fireplace dampers.
- 4 - Follow the lighting instructions. Turn on the appliance that is being inspected. Adjust the thermostat so that the appliance operates continuously.
- 5 - After the main burner has operated for 5 minutes, test for leaks of flue gases at the draft hood relief opening. Use the flame of a match or candle.
- 6 - After determining that each appliance connected to the common venting system is venting properly, (step 3) return all doors, windows, exhaust fans, fireplace dampers, and any other gas-burning appliances to their previous mode of operation.

7 - If a venting problem is found during any of the preceding tests, the common venting system must be modified to correct the problem.

Resize the common venting system to the minimum vent pipe size determined by using the appropriate tables in Appendix G. (These are in the current standards of the National Fuel Gas Code ANSI Z223.1.

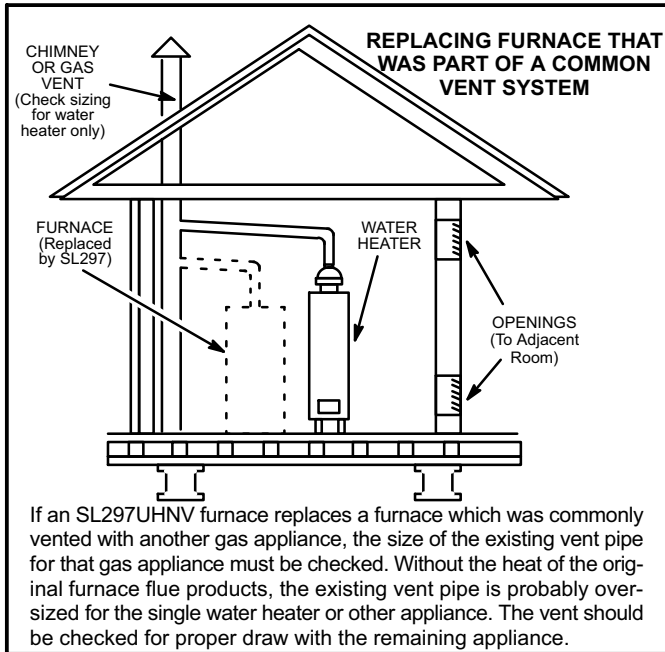

FIGURE 18

Exhaust Piping (Figures 19, 20, 22 and 23)

The vent adapter must be attached to the exhaust coupling on the furnace top panel. Use the provided bands. See steps below.

- 1 - Remove the caution sticker from vent adapter.
- 2 - Fully insert vent adapter with both bands loosely attached on the furnace exhaust coupling.
- 3 - Insert PVC exhaust pipe through vent adapter. Ensure vent pipe is fully seated into exhaust coupling.
- 4 - Tighten both top and bottom bands to 40 in lbs. See figure 19.
- 5 - Tighten top band.

Route piping to outside of structure. Continue with installation following instructions given in piping termination section.

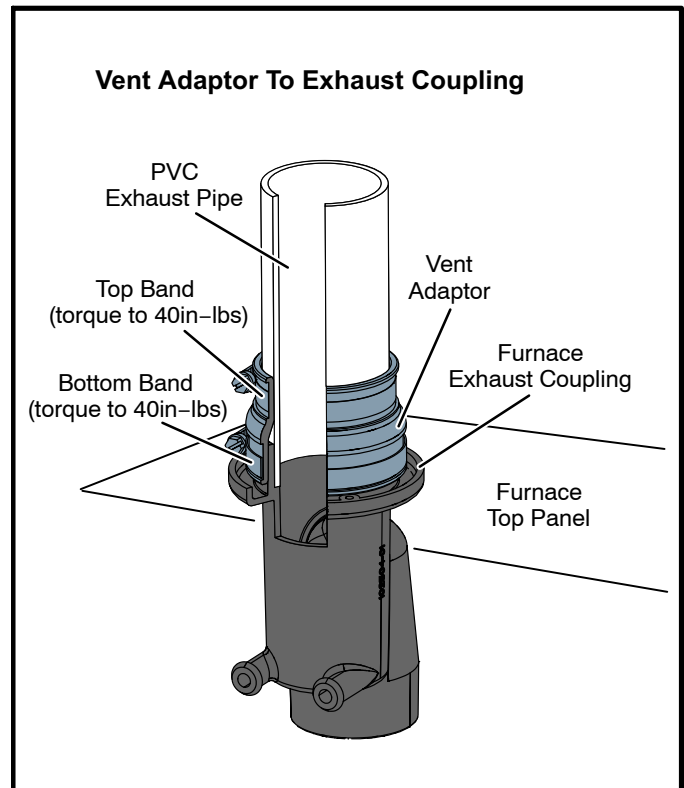

FIGURE 19

⚠ CAUTION

Do not discharge exhaust into an existing stack or stack that also serves another gas appliance. If vertical discharge through an existing unused stack is required, insert PVC pipe inside the stack until the end is even with the top or outlet end of the metal stack.

⚠ CAUTION

The exhaust vent pipe operates under positive pressure and must be completely sealed to prevent leakage of combustion products into the living space.

Vent Piping Guidelines

NOTE - Lennox has approved the use of DuraVent® and Centrotherm manufactured vent pipe and terminations as an option to PVC. When using the PolyPro® by DuraVent or InnoFlue® by Centrotherm venting system the vent pipe requirements stated in the unit installation instruction – minimum & maximum vent lengths, termination clearances, etc. – apply and must be followed. Follow the instructions provided with PolyPro by DuraVent and InnoFlue by Centrotherm venting system for assembly or if requirements are more restrictive. The PolyPro by DuraVent and InnoFlue by Centrotherm venting system must also follow the uninsulated and unconditioned space criteria listed in table 23.

The SL297UHNV is installed as a Direct Vent gas central furnace only.

NOTE - In Direct Vent installations, combustion air is taken from outdoors and flue gases are discharged outdoors.

Intake and exhaust pipe sizing -- Size pipe according to tables 20 and 21. Count all elbows inside and outside the home. Table 20 lists the *minimum* vent pipe lengths permitted. Table 21 lists the *maximum* pipe lengths permitted.

Regardless of the diameter of pipe used, the standard roof and wall terminations described in section *Exhaust Piping Terminations* should be used. Exhaust vent termination pipe is sized to optimize the velocity of the exhaust gas as it exits the termination. Refer to table 24.

In some applications which permit the use of several different sizes of vent pipe, a combination vent pipe may be used. Contact Lennox' Application Department for assistance in sizing vent pipe in these applications.

NOTE - The exhaust collar on all models is sized to accommodate 2" Schedule 40 vent pipe. In horizontal applications, any transition to exhaust pipe larger than 2" must be made in vertical runs of the pipe. Therefore a 2" elbow must be added before the pipe is transitioned to any size larger than 2". This elbow must be added to the elbow count used to determine acceptable vent lengths. Contact the Application Department for more information concerning sizing of vent systems which include multiple pipe sizes.

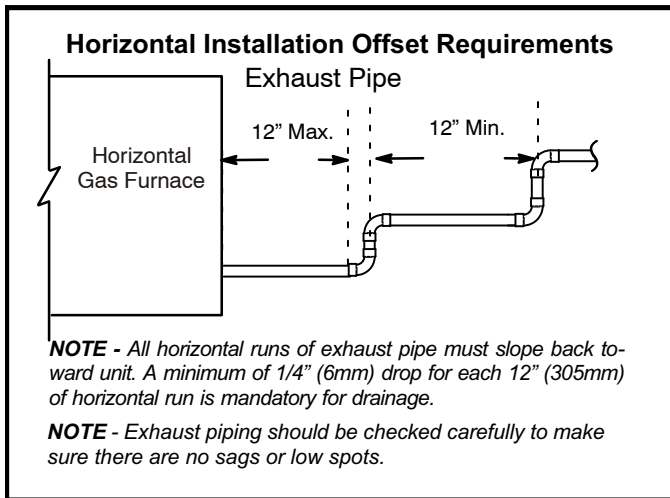

FIGURE 20

**TABLE 20
MINIMUM VENT PIPE LENGTHS**

SL297UHNV MODEL	MIN. VENT LENGTH*
040, 060, 080	15 ft. or 5 ft. plus 2 elbows or 10 ft. plus 1 elbow

*Any approved termination may be added to the minimum length listed.

Use the following steps to correctly size vent pipe diameter.

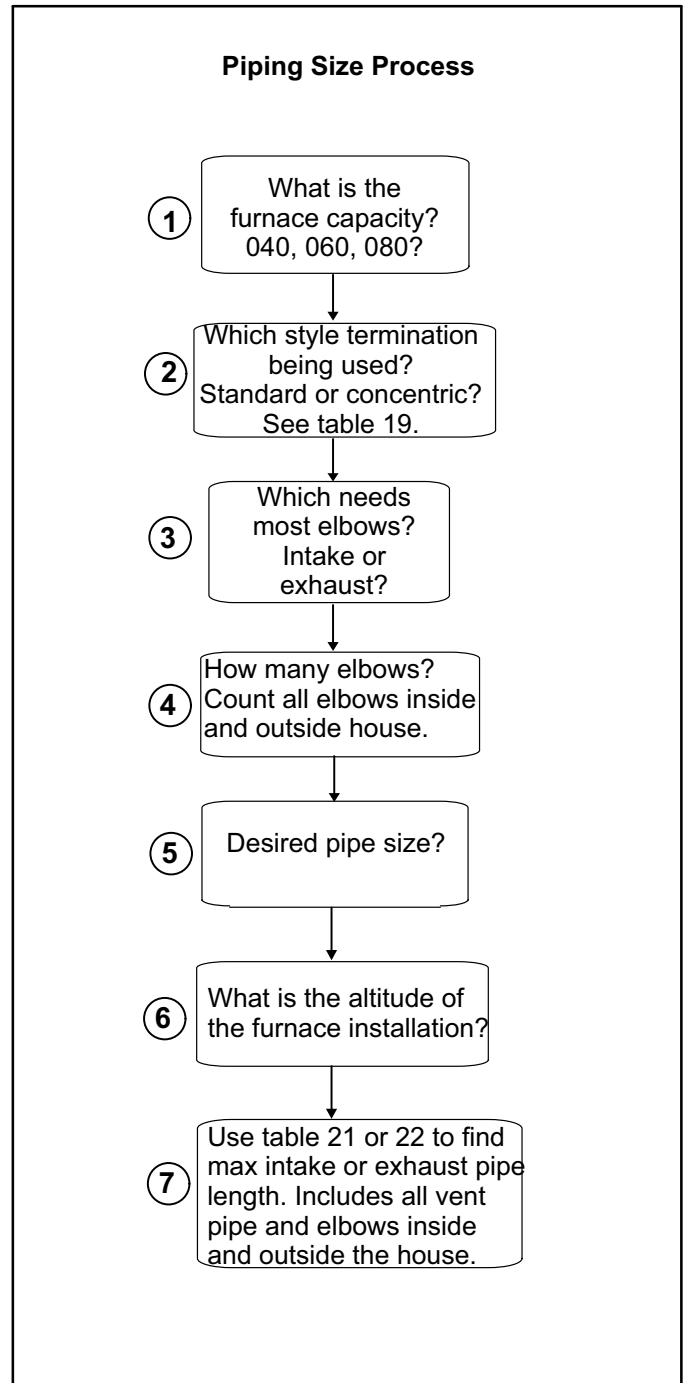

FIGURE 21

⚠ IMPORTANT

Do not use screens or perforated metal in exhaust or intake terminations. Doing so will cause freeze-ups and may block the terminations.

**TABLE 21
Maximum Allowable Intake or Exhaust Vent Length in Feet**

NOTE - Size intake and exhaust pipe length separately. Values in table are for Intake OR Exhaust, not combined total. Both Intake and Exhaust must be same pipe size.

NOTE - Additional vent pipe and elbows used to terminate the vent pipe outside the structure must be included in the total vent length calculation.

Standard Termination at Elevation 0 - 4500 ft						
Number Of 90° Elbows Used	2" Pipe			3" Pipe		
	Model			Model		
	040	060	080	040	060	080
1	81	66	44	138	137	118
2	76	61	39	133	132	113
3	71	56	34	128	127	108
4	66	51	29	123	122	103
5	61	46	24	118	117	98
6	56	41	19	113	112	93
7	51	36	14	108	107	88
8	46	31	n/a	103	102	83
9	41	26		98	97	78
10	36	21		93	92	73
Standard Termination at Elevation 4501-6000 ft						
Number Of 90° Elbows Used	2" Pipe			3" Pipe		
	Model			Model		
	040	060	080	040	060	080
1	81	41	34	138	105	100
2	76	36	29	133	100	95
3	71	31	24	128	95	90
4	66	26	19	123	90	85
5	61	21	14	118	85	80
6	56	16	9	113	80	75
7	51	11	n/a	108	75	70
8	46	n/a		103	70	65
9	41			98	65	60
10	36			93	60	55
Standard Termination at Elevation 6001-7500 ft						
Number Of 90° Elbows Used	2" Pipe			3" Pipe		
	Model			Model		
	040	060	080	040	060	080
1	81	29	24	138	105	100
2	76	24	19	133	100	95
3	71	19	14	128	95	90
4	66	14	9	123	90	85
5	61	9	n/a	118	85	80
6	56	n/a		113	80	75
7	51			108	75	70
8	46			103	70	65
9	41			98	65	60
10	36			93	60	55

TABLE 21 Continued
Maximum Allowable Intake or Exhaust Vent Length in Feet

Size intake and exhaust pipe length separately. Values in table are for Intake OR Exhaust, not combined total. Both Intake and Exhaust must be same pipe size.

Concentric Termination at Elevation 0 - 4500 ft						
Number Of 90° Elbows Used	2" Pipe			3" Pipe		
	Model			Model		
	040	060	080	040	060	080
1	73	58	42	121	121	114
2	68	53	37	116	116	109
3	63	48	32	111	111	104
4	58	43	27	106	106	99
5	53	38	22	101	101	94
6	48	33	17	96	96	89
7	43	28	12	91	91	84
8	38	23	n/a	86	86	79
9	33	18		81	81	74
10	28	13		76	76	69
Concentric Termination at Elevation 4501-6000 ft						
Number Of 90° Elbows Used	2" Pipe			3" Pipe		
	Model			Model		
	040	060	080	040	060	080
1	73	33	32	121	89	89
2	68	28	27	116	84	84
3	63	23	22	111	79	79
4	58	18	17	106	74	74
5	53	13	12	101	69	69
6	48	n/a	n/a	96	64	64
7	43			91	59	59
8	38			86	54	54
9	33			81	49	49
10	28			76	44	44
Concentric Termination at Elevation 6001-7500 ft						
Number Of 90° Elbows Used	2" Pipe			3" Pipe		
	Model			Model		
	040	060	080	040	060	080
1	73	27	22	121	89	89
2	68	22	17	116	84	84
3	63	17	12	111	79	79
4	58	12	7	106	74	74
5	53	7	n/a	101	69	69
6	48	n/a		96	64	64
7	43			91	59	59
8	38			86	54	54
9	33		81	49	49	
10	28			76	44	44

TABLE 22

Maximum Allowable Exhaust Vent Lengths With Furnace Installed in a Closet or Basement Using Ventilated Attic or Crawl Space For Intake Air in Feet

NOTE - Size intake and exhaust pipe length separately. Values in table are for Intake OR Exhaust, not combined total. Both Intake and Exhaust must be same pipe size.

NOTE - Additional vent pipe and elbows used to terminate the vent pipe outside the structure must be included in the total vent length calculation.

Standard Termination at Elevation 0 - 4500 ft						
Number Of 90° Elbows Used	2" Pipe			3" Pipe		
	Model			Model		
	040	060	080	040	060	080
1	71	56	34	118	117	98
2	66	51	29	113	112	93
3	61	46	24	108	107	88
4	56	41	19	103	102	83
5	51	36	14	98	97	78
6	46	31	9	93	92	73
7	41	26	4	88	87	68
8	36	21	n/a	83	82	63
9	31	16		78	77	58
10	26	11		73	72	53
Standard Termination at Elevation 4501-6000 ft						
Number Of 90° Elbows Used	2" Pipe			3" Pipe		
	Model			Model		
	040	060	080	040	060	080
1	71	31	24	118	85	80
2	66	26	19	113	80	75
3	61	21	14	108	75	70
4	56	16	9	103	70	65
5	51	11	n/a	98	65	60
6	46	n/a		93	60	55
7	41			88	55	50
8	36			83	50	45
9	31			78	45	40
10	26			73	40	35
Standard Termination at Elevation 6501-7500 ft						
Number Of 90° Elbows Used	2" Pipe			3" Pipe		
	Model			Model		
	040	060	080	040	060	080
1	71	19	14	118	85	80
2	66	14	9	113	80	75
3	61	9	n/a	108	75	70
4	56	n/a		103	70	65
5	51			98	65	60
6	46			93	60	55
7	41			88	55	50
8	36			83	50	45
9	31			78	45	40
10	26			73	40	35

TYPICAL EXHAUST AND INTAKE PIPE CONNECTIONS IN UPFLOW APPLICATIONS

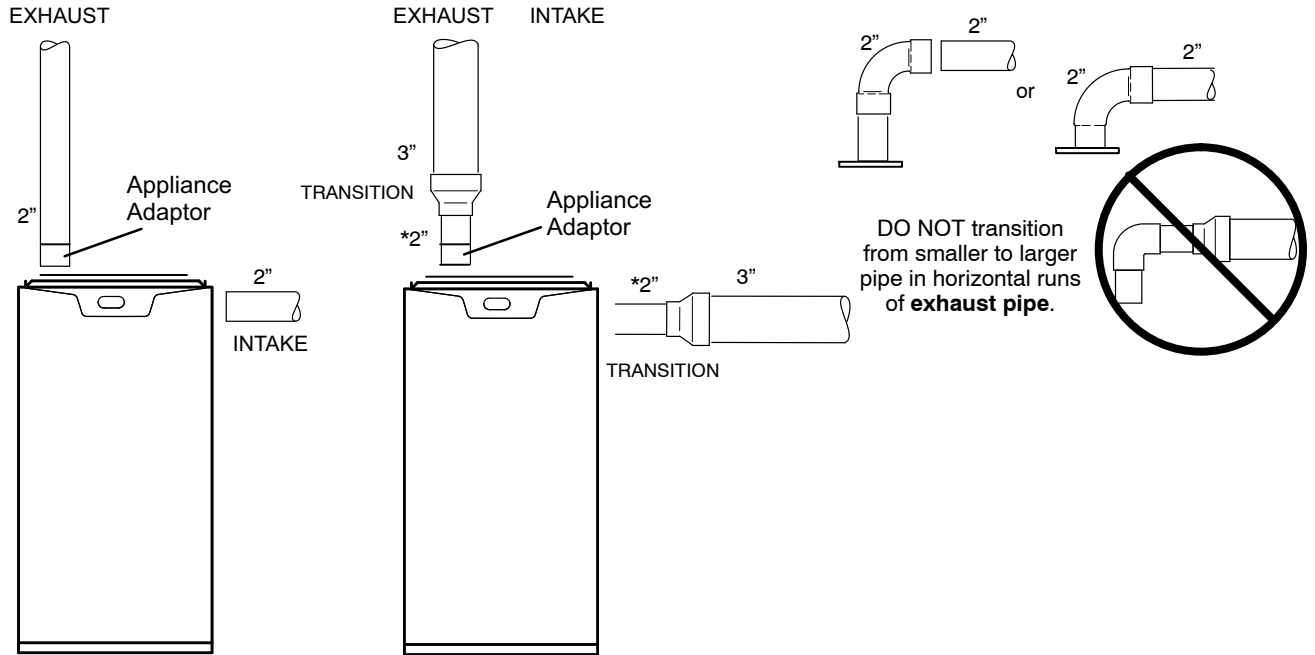

* When transitioning up in pipe size, use the shortest length of 2" PVC pipe possible.

FIGURE 22

TYPICAL EXHAUST AND INTAKE PIPE CONNECTIONS IN HORIZONTAL APPLICATIONS (RIGHT HAND DISCHARGE SHOWN)

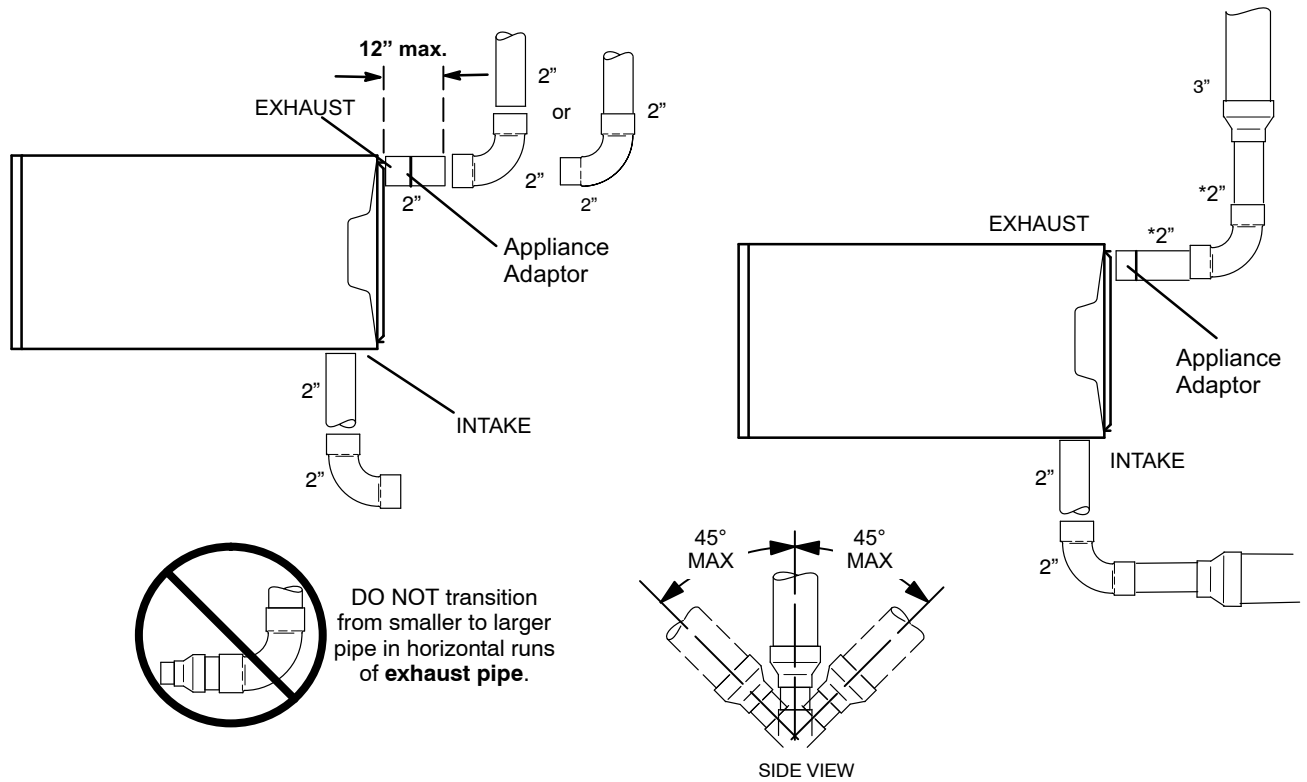

* When transitioning up in pipe size, use the shortest length of 2" PVC pipe possible.

FIGURE 23

Intake Piping

The SL297UHNV furnace is installed in **direct vent** applications.

Follow the next two steps when installing the unit in **Direct Vent applications**, where combustion air is taken from outdoors and flue gases are discharged outdoors. **The provided air intake screen must not be used in direct vent applications (outdoors).**

- 1 - Use transition solvent cement or a sheet metal screw to secure the intake pipe to the inlet air connector.
- 2 - Route piping to outside of structure. Continue with installation following instructions given in general guidelines for piping terminations and intake and exhaust piping terminations for direct vent sections. Refer to table 21 for pipe sizes.
- 3 - Use a sheet metal screw to secure the intake pipe to the connector, if desired.

General Guidelines for Vent Terminations

In Direct Vent applications, combustion air is taken from outdoors and the flue gases are discharged to the outdoors. The SL297UHNV is then classified as a direct vent, Category IV gas furnace.

In Direct Vent applications, the vent termination is limited by local building codes. In the absence of local codes, refer to the current National Fuel Gas Code ANSI Z223-1/NFPA 54 in U.S.A., and current CSA-B149 Natural Gas and Propane Installation Codes in Canada for details.

Position termination according to location given in figure 25. In addition, position termination so it is free from any obstructions and 12" above the average snow accumulation.

At vent termination, care must be taken to maintain protective coatings over building materials (prolonged exposure to exhaust condensate can destroy protective coatings). It is recommended that the exhaust outlet not be located within 6 feet (1.8m) of an outdoor AC unit because the condensate can damage the painted coating.

NOTE - See table 23 for maximum allowed exhaust pipe length without insulation in unconditioned space during winter design temperatures below 32°F (0°C). If required exhaust pipe should be insulated with 1/2" (13mm) Armaflex or equivalent. In extreme cold climate areas, 3/4" (19mm) Armaflex or equivalent may be necessary. Insulation must be protected from deterioration. Armaflex with UV protection is permissible. Basements or other enclosed areas that are not exposed to the outdoor ambient temperature and are above 32 degrees F (0°C) are to be considered conditioned spaces.

IMPORTANT

Do not use screens or perforated metal in exhaust terminations. Doing so will cause freeze-ups and may block the terminations.

IMPORTANT

**For Canadian Installations Only:
In accordance to CSA International B149 installation codes, the minimum allowed distance between the combustion air intake inlet and the exhaust outlet of other appliances shall not be less than 12 inches (305mm).**

TABLE 23
Maximum Allowable Exhaust Vent Pipe Length (in ft.) Without Insulation In Unconditioned Space For
Winter Design Temperatures Two - Stage High Efficiency Furnace

Winter Design Temperatures ¹ °F (°C)	Vent Pipe Diameter	Unit Input Size					
		040		060		080	
		PVC	2PP	PVC	2PP	PVC	2PP
32 to 21 (0 to -6)	2 in.	21	18	33	30	46	42
	3 in.	12	12	21	21	30	30
20 to 1 (-7 to -17)	2 in.	11	9	19	17	28	25
	3 in.	N/A	N/A	9	9	16	16
0 to -20 (-18 to -29)	2 in.	6	4	12	10	19	16
	3 in.	N/A	N/A	N/A	N/A	8	8

¹Refer to 99% Minimum Design Temperature table provided in the current edition of the ASHRAE Fundamentals Handbook.

² Poly-Propylene vent pipe (PP) by Duravent and Centrotherm.

NOTE - Concentric terminations are the equivalent of 5' and should be considered when measuring pipe length.

NOTE - Maximum uninsulated vent lengths listed may include the termination (vent pipe exterior to the structure) and cannot exceed 5 linear feet or the maximum allowable intake or exhaust vent length listed in table 21 or 22 which ever is less.

NOTE - If insulation is required in an unconditioned space, it must be located on the pipe closest to the furnace. See figure 24.

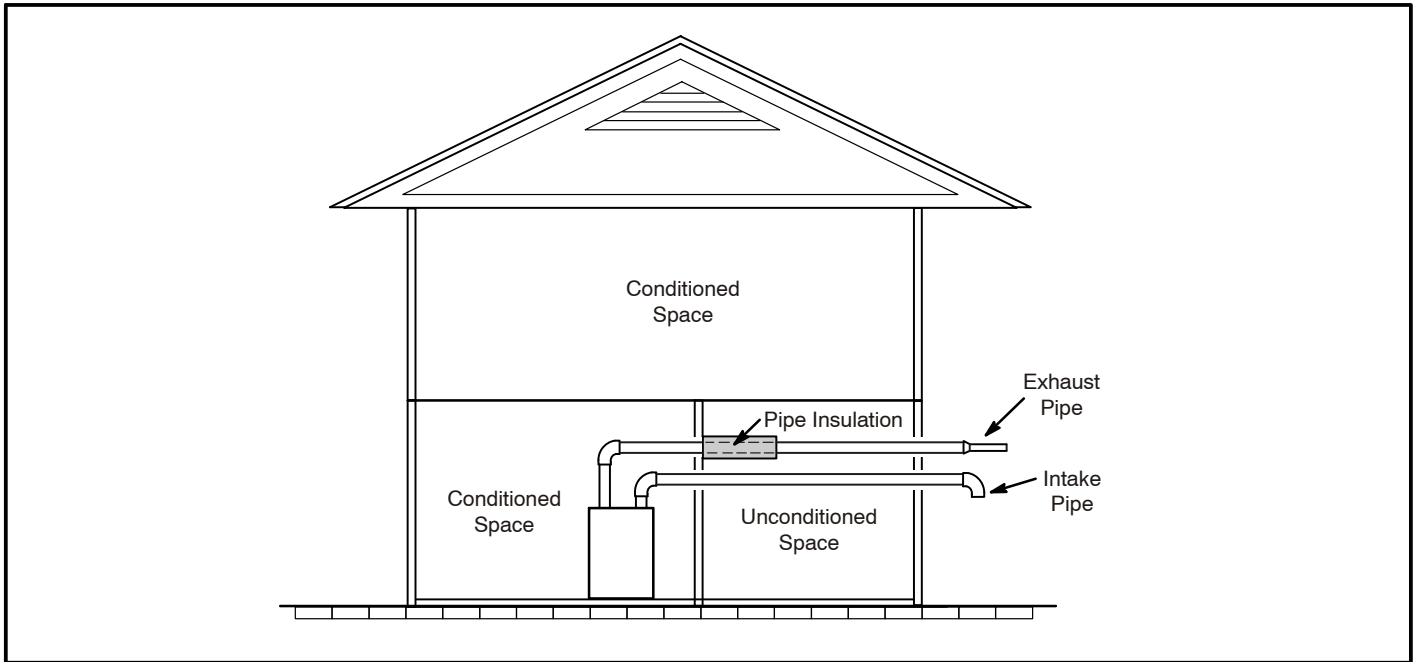
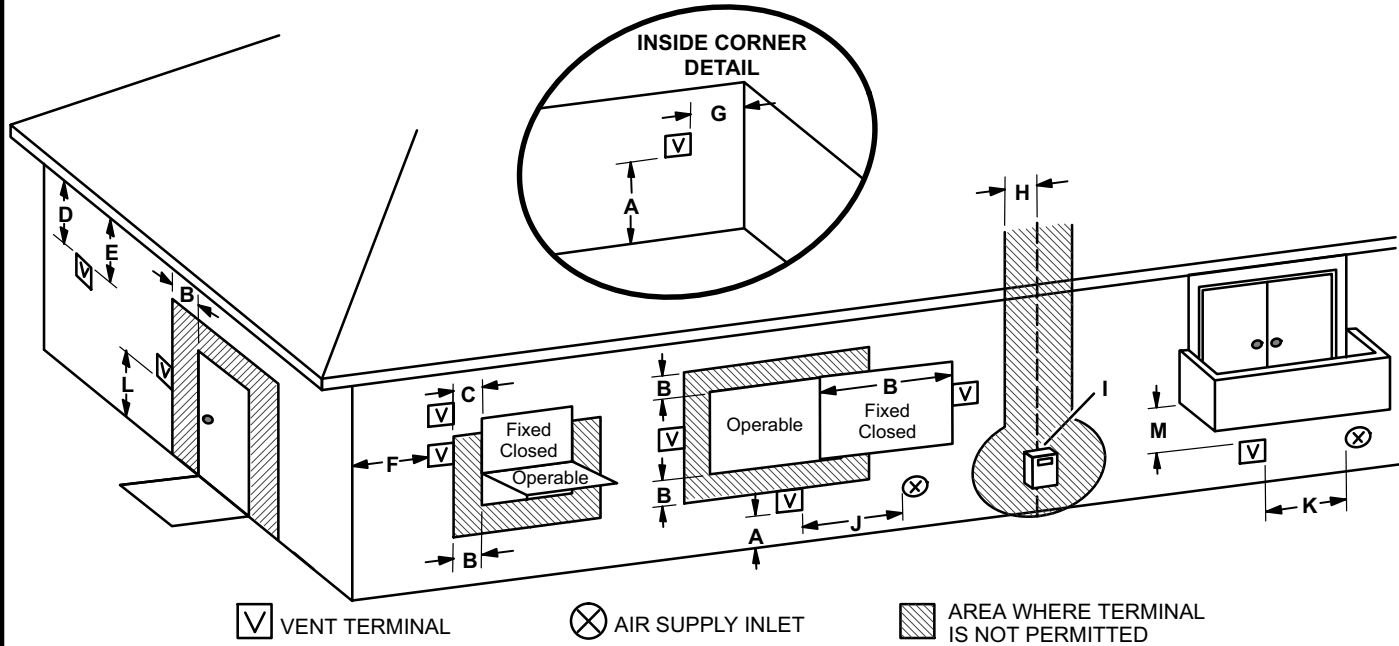

FIGURE 24

VENT TERMINATION CLEARANCES FOR DIRECT VENT INSTALLATIONS IN THE US AND CANADA



	US Installations ¹	Canadian Installations ²	
A =	Clearance above grade, veranda, porch, deck or balcony	12 inches (305mm) or 12 in. (305mm) above average snow accumulation.	12 inches (305mm) or 12 in. (305mm) above average snow accumulation.
B =	Clearance to window or door that may be opened	6 inches (152mm) for appliances <10,000 Btuh (3kw), 9 inches (228mm) for appliances > 10,000 Btuh (3kw) and <50,000 Btuh (15 kw), 12 inches (305mm) for appliances > 50,000 Btuh (15kw)	6 inches (152mm) for appliances <10,000 Btuh (3kw), 12 inches (305mm) for appliances > 10,000 Btuh (3kw) and <100,000 Btuh (30kw), 36 inches (.9m) for appliances > 100,000 Btuh (30kw)
C =	Clearance to permanently closed window	* 12"	* 12"
D =	Vertical clearance to ventilated soffit located above the terminal within a horizontal distance of 2 feet (610mm) from the center line of the terminal	* Equal to or greater than soffit depth	* Equal to or greater than soffit depth
E =	Clearance to unventilated soffit	* Equal to or greater than soffit depth	* Equal to or greater than soffit depth
F =	Clearance to outside corner	* No minimum to outside corner	* No minimum to outside corner
G =	Clearance to inside corner	*	*
H =	Clearance to each side of center line extended above meter / regulator assembly	3 feet (.9m) within a height 15 feet (4.5m) above the meter / regulator assembly	3 feet (.9m) within a height 15 feet (4.5m) above the meter / regulator assembly
I =	Clearance to service regulator vent outlet	* 3 feet (.9m)	3 feet (.9m)
J =	Clearance to non-mechanical air supply inlet to building or the combustion air inlet to any other appliance	6 inches (152mm) for appliances <10,000 Btuh (3kw), 9 inches (228mm) for appliances > 10,000 Btuh (3kw) and <50,000 Btuh (15 kw), 12 inches (305mm) for appliances > 50,000 Btuh (15kw)	6 inches (152mm) for appliances <10,000 Btuh (3kw), 12 inches (305mm) for appliances > 10,000 Btuh (3kw) and <100,000 Btuh (30kw), 36 inches (.9m) for appliances > 100,000 Btuh (30kw)
K =	Clearance to mechanical air supply inlet	3 feet (.9m) above if within 10 feet (3m) horizontally	6 feet (1.8m)
L =	Clearance above paved sidewalk or paved driveway located on public property	* 7 feet (2.1m)	7 feet (2.1m)†
M =	Clearance under veranda, porch, deck or balcony	*12 inches (305mm)‡	12 inches (305mm)‡

¹ In accordance with the current ANSI Z223.1/NFPA 54 Natural Fuel Gas Code

² In accordance with the current CSA B149.1, Natural Gas and Propane Installation Code

† A vent shall not terminate directly above a sidewalk or paved driveway that is located between two single family dwellings and serves both dwellings.

‡ Permitted only if veranda, porch, deck or balcony is fully open on a minimum of two sides beneath the floor. Lennox recommends avoiding this location if possible.

*For clearances not specified in ANSI Z223.1/NFPA 54 or CSA B149.1, clearance will be in accordance with local installation codes and the requirements of the gas supplier and these installation instructions."

FIGURE 25

Details of Intake and Exhaust Piping Terminations for Direct Vent Installations

NOTE - In Direct Vent installations, combustion air is taken from outdoors and flue gases are discharged to outdoors.

NOTE - Flue gas may be slightly acidic and may adversely affect some building materials. If any vent termination is used and the flue gasses may impinge on the building material, a corrosion-resistant shield (minimum 24 inches square) should be used to protect the wall surface. If the optional tee is used, the protective shield is recommended. The shield should be constructed using wood, plastic, sheet metal or other suitable material. All seams, joints, cracks, etc. in the affected area should be sealed using an appropriate sealant. See figure 29.

Intake and exhaust pipes may be routed either horizontally through an outside wall or vertically through the roof. In attic or closet installations, vertical termination through the roof is preferred. Figures 26 through 34 show typical terminations.

1. Intake and exhaust terminations are not required to be in the same pressure zone. You may exit the intake on one side of the structure and the exhaust on another side (figure 27). You may exit the exhaust out the roof and the intake out the side of the structure (figure 28).
2. Intake and exhaust pipes should be placed as close together as possible at termination end (refer to illustrations). Maximum separation is 3" (76MM) on roof terminations and 6" (152MM) on side wall terminations.

NOTE - When venting in different pressure zones, the maximum separation requirement of intake and exhaust pipe DOES NOT apply.

3. On roof terminations, the intake piping should terminate straight down using two 90° elbows (See figure 26).
4. Exhaust piping must terminate straight out or up as shown. A reducer may be required on the exhaust piping at the point where it exits the structure to improve the velocity of exhaust away from the intake piping. See table 24.

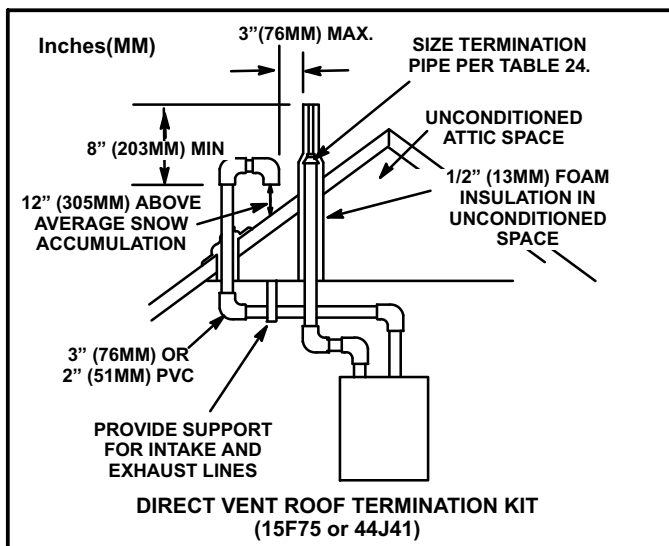

FIGURE 26

TABLE 24
EXHAUST PIPE TERMINATION SIZE REDUCTION

SL297UHNV MODEL	Termination Pipe Size
*040 and 060	1-1/2" (38MM)
*080	2" (51MM)

*SL297UHNV-040, -060 and -080 units with the flush mount termination must use the 1-1/2" accelerator supplied with the kit.

NOTE - Care must be taken to avoid recirculation of exhaust back into intake pipe.

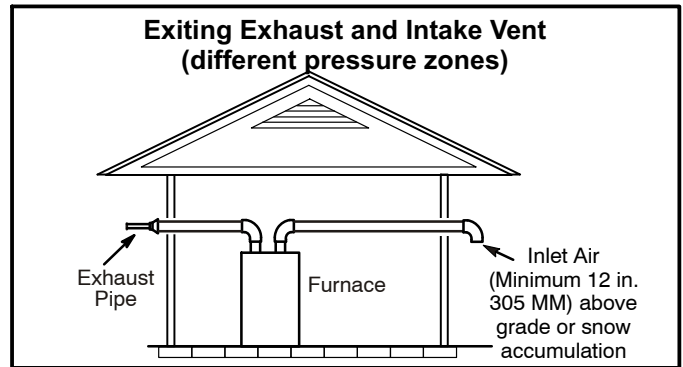

FIGURE 27

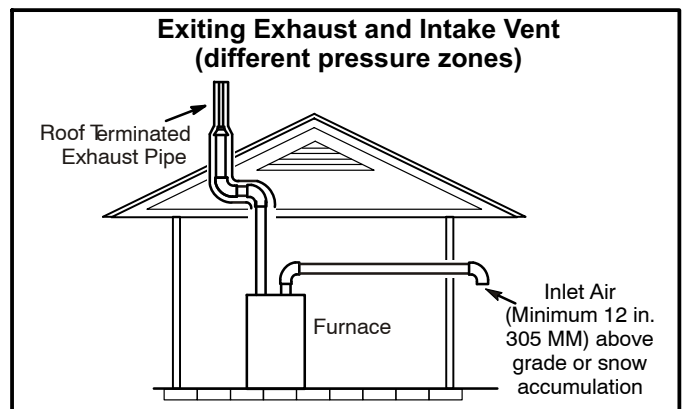
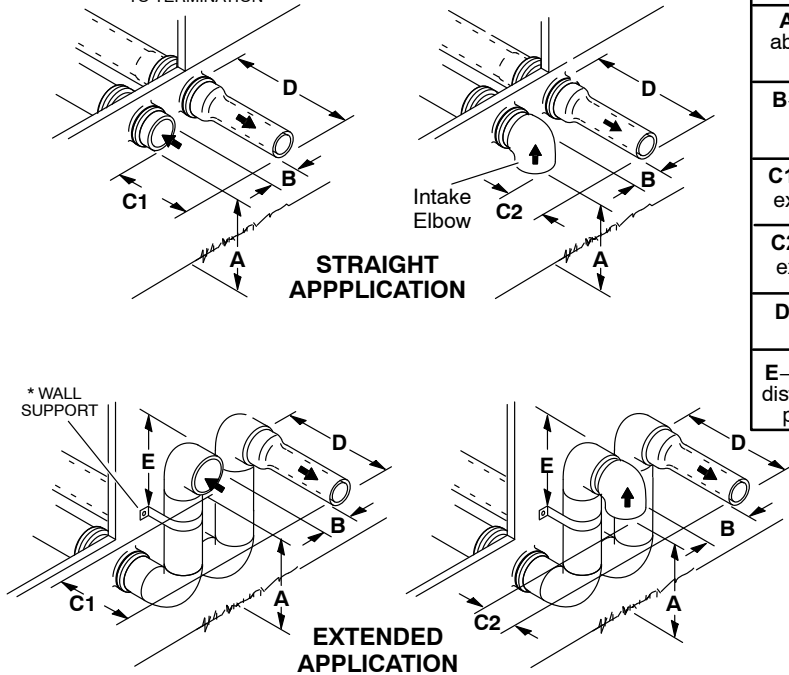

FIGURE 28

5. On field-supplied terminations for side wall exit, exhaust piping may extend a maximum of 12 inches (305MM) for 2" PVC and 20 inches (508MM) for 3" (76MM) PVC beyond the outside wall. Intake piping should be as short as possible. See figure 29.
6. On field-supplied terminations, a minimum distance between the end of the exhaust pipe and the end of the intake pipe without a termination elbow is 8" and a minimum distance of 6" with a termination elbow. See figure 29.
7. If intake and exhaust piping must be run up a side wall to position above snow accumulation or other obstructions, piping must be supported. At least one bracket must be used within 6" from the top of the elbow and then every 24" (610mm) as shown in figure 29, to prevent any movement in any direction. When exhaust and intake piping must be run up an outside wall, the exhaust piping must be terminated with pipe sized per table 24. The intake piping may be equipped with a 90° elbow turndown. Using turndown will add 5 feet (1.5m) to the equivalent length of the pipe.
8. A multiple furnace installation may use a group of up to four terminations assembled together horizontally, as shown in figure 33.

FIELD FABRICATED WALL TERMINATION

NOTE - FIELD-PROVIDED REDUCER MAY BE REQUIRED TO ADAPT LARGER VENT PIPE SIZE TO TERMINATION



	2" (51mm) Vent Pipe	3" (76mm) Vent Pipe
A - Minimum clearance above grade or average snow accumulation	12" (305 mm)	12" (305 mm)
B - Maximum horizontal separation between intake and exhaust	6" (152 mm)	6" (152 mm)
C1 -Minimum from end of exhaust to inlet of intake	8" (203 mm)	8" (203 mm)
C2 -Minimum from end of exhaust to inlet of intake	6" (152 mm)	6" (152 mm)
D - Maximum exhaust pipe length	12" (305 mm)	20" (508 mm)
E - Maximum wall support distance from top of each pipe (intake/exhaust)	6" (152 mm)	6" (152 mm)

See venting table 21 for maximum venting lengths with this arrangement.

* Use wall support every 24" (610 mm). Use two wall supports if extension is greater than 24" (610 mm) but less than 48" (1219 mm).

NOTE - One wall support must be within 6" (152 mm) from top of each pipe (intake and exhaust) to prevent movement in any direction.

ALTERNATE TERMINATIONS (TEE & FORTY-FIVE DEGREE ELBOWS ONLY)

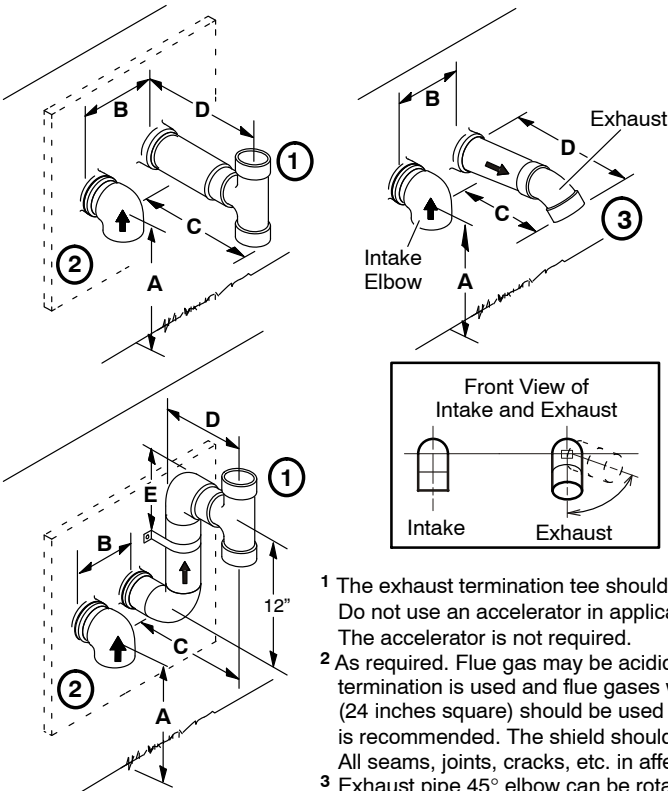

	2" (51MM) Vent Pipe	3" (76MM) Vent Pipe
A - Clearance above grade or average snow accumulation	12" (305 mm) Min.	12" (305 mm) Min.
B - Horizontal separation between intake and exhaust	6" (152 mm) Min. 24" (610 mm) Max.	6" (152 mm) Min. 24" (610 mm) Max.
C - Minimum from end of exhaust to inlet of intake	9" (227 mm) Min.	9" (227 mm) Min.
D - Exhaust pipe length	12" (305 mm) Min. 16" (405 mm) Max.	12" (305 mm) Min. 20" (508 mm) Max.
E - Wall support distance from top of each pipe (intake/exhaust)	6" (152 mm) Max.	6" (152 mm) Max.

- 1 The exhaust termination tee should be connected to the 2" or 3" PVC flue pipe as shown in the illustration. Do not use an accelerator in applications that include an exhaust termination tee. The accelerator is not required.
- 2 As required. Flue gas may be acidic and may adversely affect some building materials. If a side wall vent termination is used and flue gases will impinge on the building materials, a corrosion-resistant shield (24 inches square) should be used to protect the wall surface. If optional tee is used, the protective shield is recommended. The shield should be constructed using wood, sheet metal or other suitable material. All seams, joints, cracks, etc. in affected area, should be sealed using an appropriate sealant.
- 3 Exhaust pipe 45° elbow can be rotated to the side away from the combustion air inlet to direct exhaust away from adjacent property. The exhaust must never be directed toward the combustion air inlet.

FIGURE 29

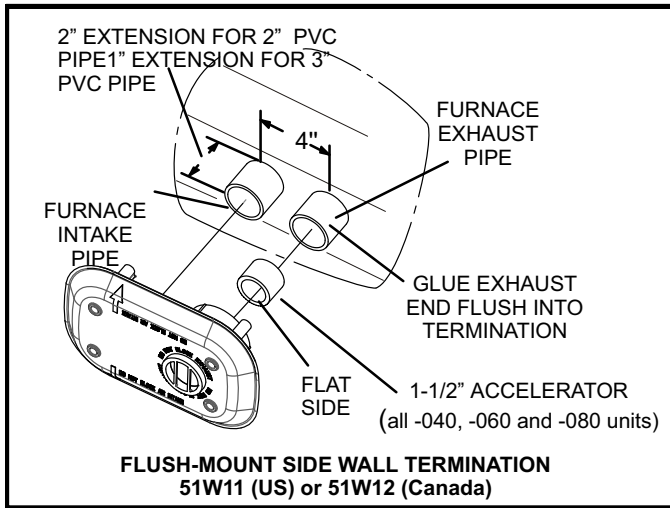

FIGURE 30

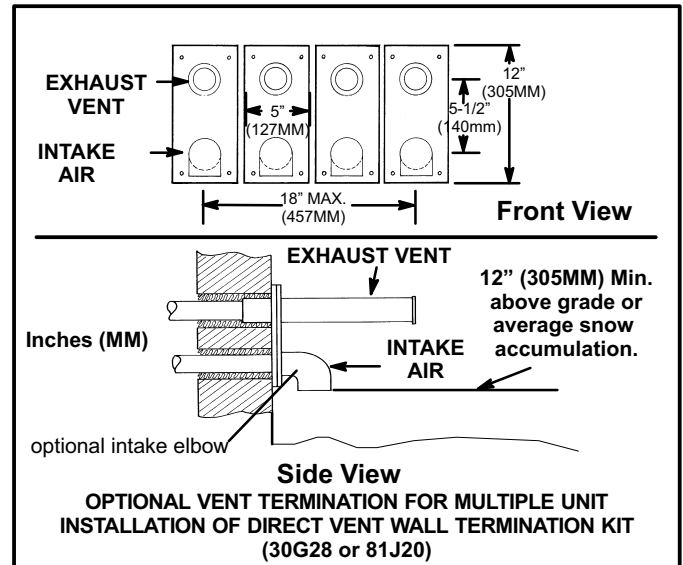

FIGURE 33

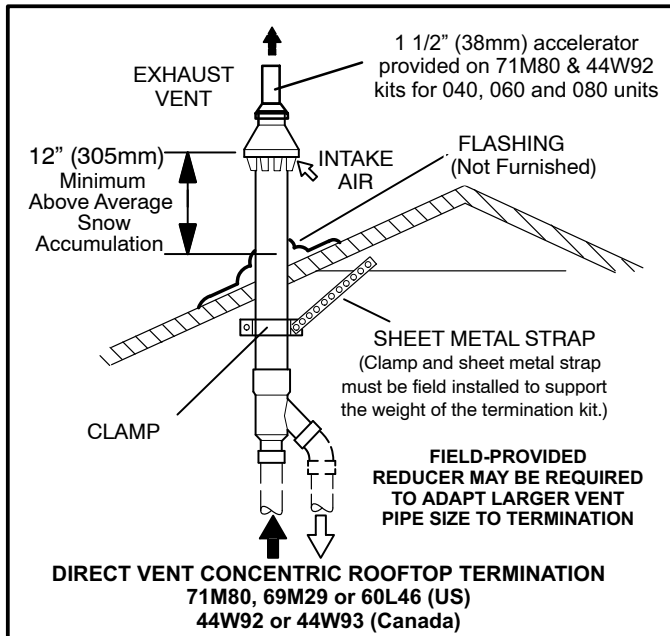

FIGURE 31

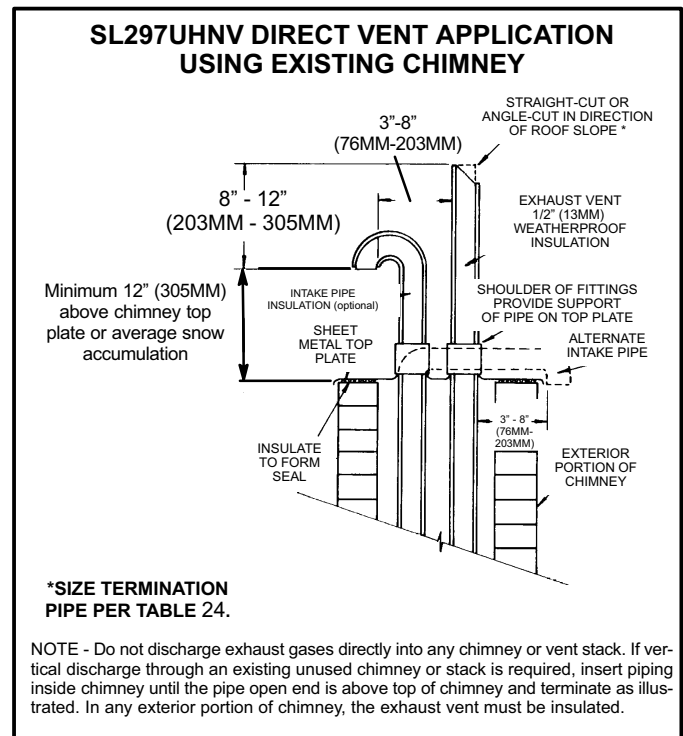

FIGURE 34

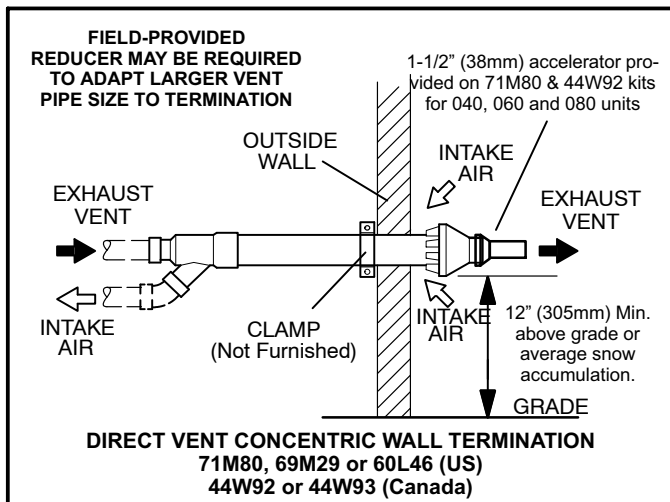

FIGURE 32

Condensate Piping

This unit is designed for either right- or left-side exit of condensate piping in upflow applications. In horizontal applications, the condensate trap must extend below the unit. An 8" service clearance is required for the condensate trap. Refer to figure 35 for condensate trap locations. Figure 43 shows trap assembly using 1/2" PVC or 3/4" PVC.

NOTE - If necessary the condensate trap may be installed up to 5' away from the furnace. Use PVC pipe to connect trap to furnace condensate outlet. Piping from furnace must slope down a minimum of 1/4" per ft. toward trap.

- 1 - Determine which side condensate piping will exit the unit, location of trap, field-provided fittings and length of PVC pipe required to reach available drain.

- 2 - For furnaces with a 1/2" drain connection use a 3/8 allen wrench and remove plug (figure 35) from the cold end header box at the appropriate location on the side of the unit. Install field-provided 1/2 NPT male fitting into cold end header box. For furnaces with a 3/4" drain connection use a large flat head screw driver or a 1/2" drive socket extension and remove plug. Install provided 3/4 NPT street elbow fitting into cold end header box. Use Teflon tape or appropriate pipe dope.
- 3 - Install the cap over the clean out opening at the base of the trap. Secure with clamp. See figure 43.
- 4 - Install drain trap using appropriate PVC fittings, glue all joints. Glue the provided drain trap as shown in figures 43. Route the condensate line to an open drain. *Condensate line must maintain a 1/4" downward slope from the furnace to the drain.*

- 5 - Figures 39 and 41 show the furnace and evaporator coil using a separate drain. If necessary the condensate line from the furnace and evaporator coil can drain together. See figures, 38, 40 and 42.

Upflow furnace (figure 40) - In upflow furnace applications the field provided vent must be a minimum 1" to a maximum 2" length above the condensate drain outlet connection. Any length above 2" may result in a flooded heat exchanger if the combined primary drain line were to become restricted.

Horizontal furnace (figure 42) - In horizontal furnace applications the field provided vent must be a minimum 4" to a maximum 5" length above the condensate drain outlet connection. Any length above 5" may result in a flooded heat exchanger if the combined primary drain line were to become restricted.

NOTE - In horizontal applications it is recommended to install a secondary drain pan underneath the unit and trap assembly.

NOTE - Appropriately sized tubing and barbed fitting may be used for condensate drain. Attach to the drain on the trap using a hose clamp. See figure 36.

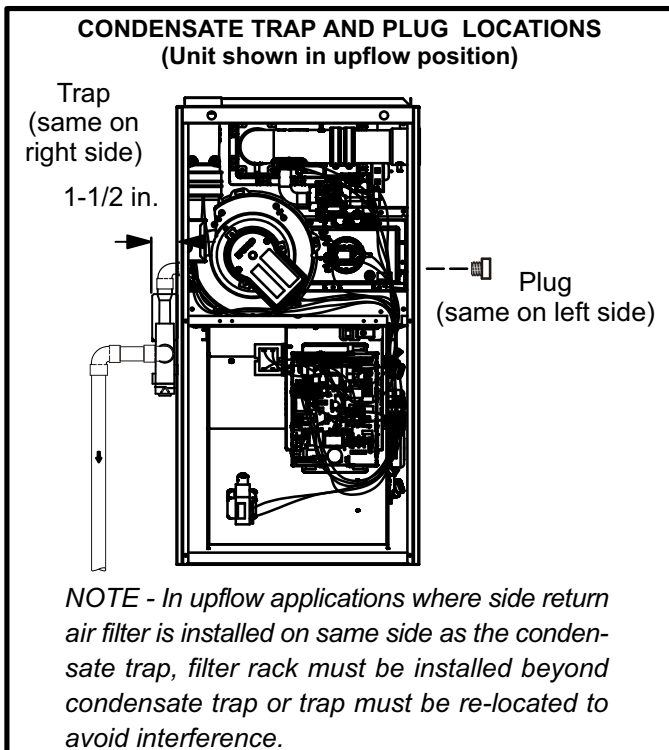

FIGURE 35

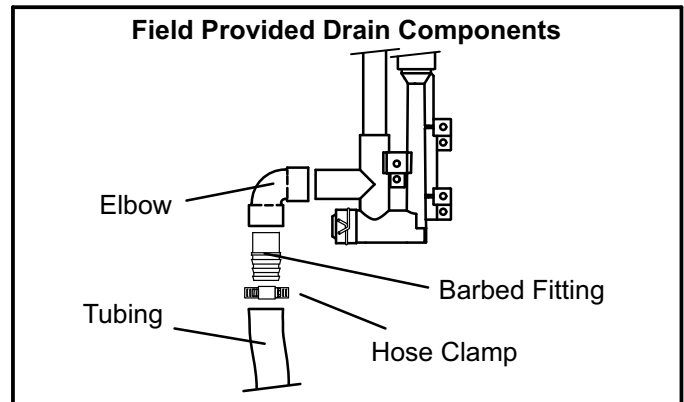

FIGURE 36

⚠ CAUTION

Do not use copper tubing or existing copper condensate lines for drain line.

- 6 - If unit will be started immediately upon completion of installation, prime trap per procedure outlined in Unit Start-Up section.

Condensate line must slope downward away from the trap to drain. If drain level is above condensate trap, condensate pump must be used. Condensate drain line should be routed within the conditioned space to avoid freezing of condensate and blockage of drain line. If this is not possible, a heat cable kit may be used

⚠ IMPORTANT

When combining the furnace and evaporator coil drains together, the A/C condensate drain outlet must be vented to relieve pressure in order for the furnace pressure switch to operate properly.

on the condensate trap and line. Heating cable kit is available from Lennox in various lengths; 6 ft. (1.8m) - kit no. 26K68; 24 ft. (7.3m) - kit no. 26K69; and 50 ft. (15.2m) - kit no. 26K70.

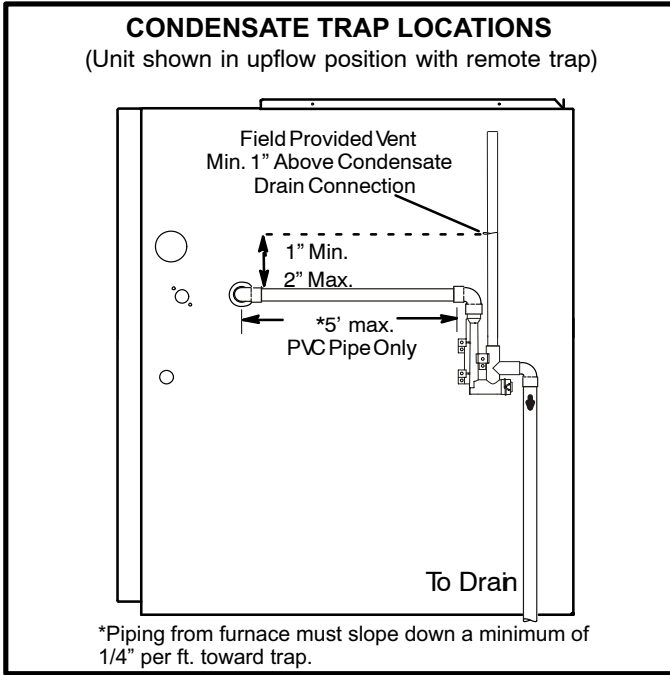

FIGURE 37

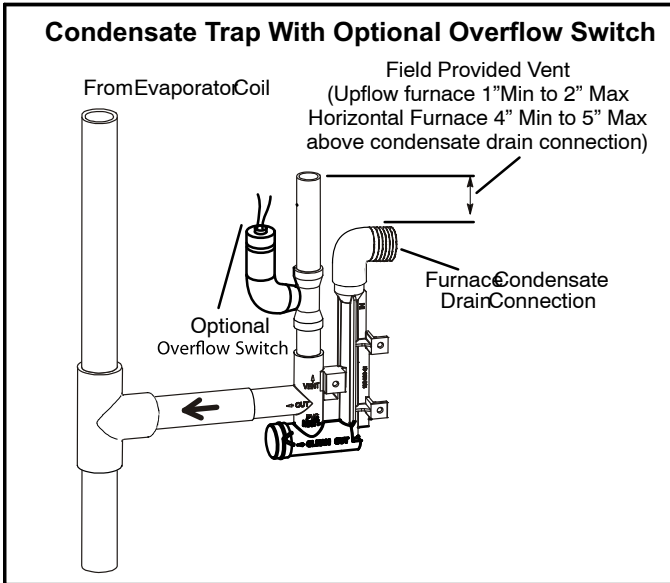

FIGURE 38

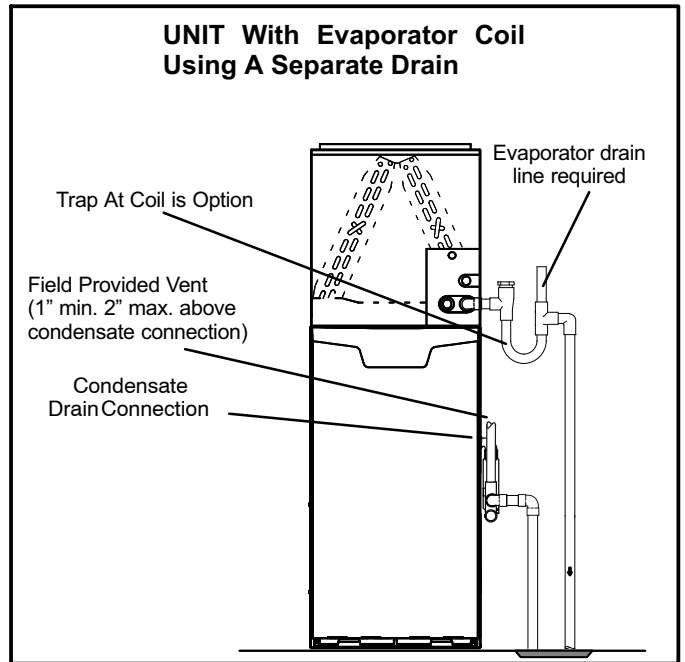

FIGURE 39

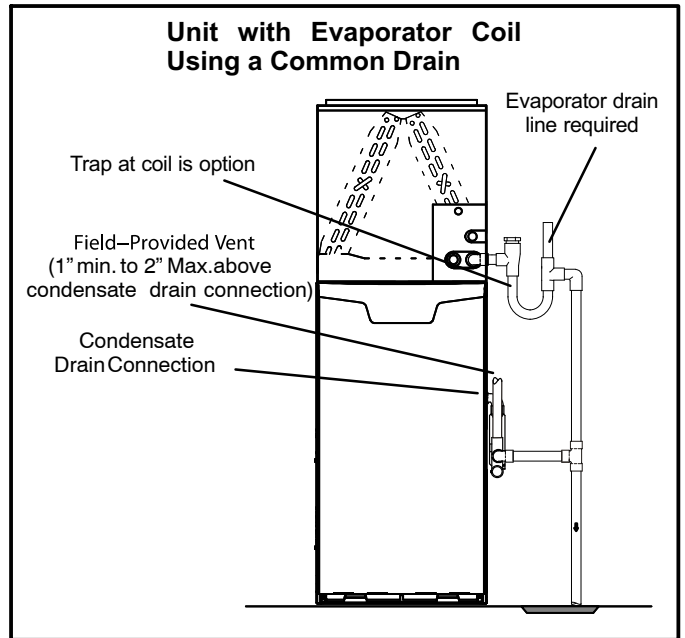
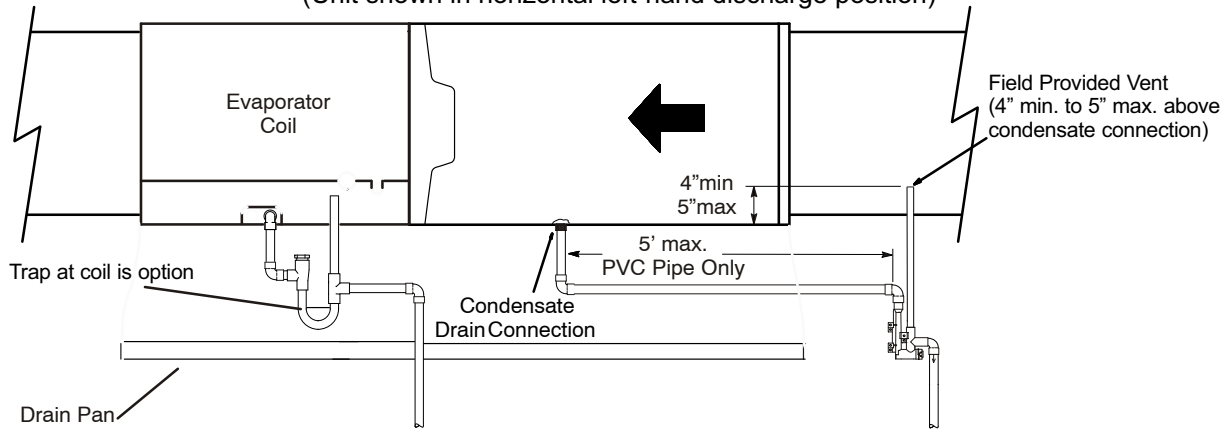

FIGURE 40

Unit with Evaporator Coil Using a Separate Drain
 (Unit shown in horizontal left-hand discharge position)



Piping from furnace and evaporator coil must slope down a minimum 1/4" per ft. toward trap

FIGURE 41

Unit with Evaporator Coil Using a Common Drain
 (Unit shown in horizontal left-hand discharge position)

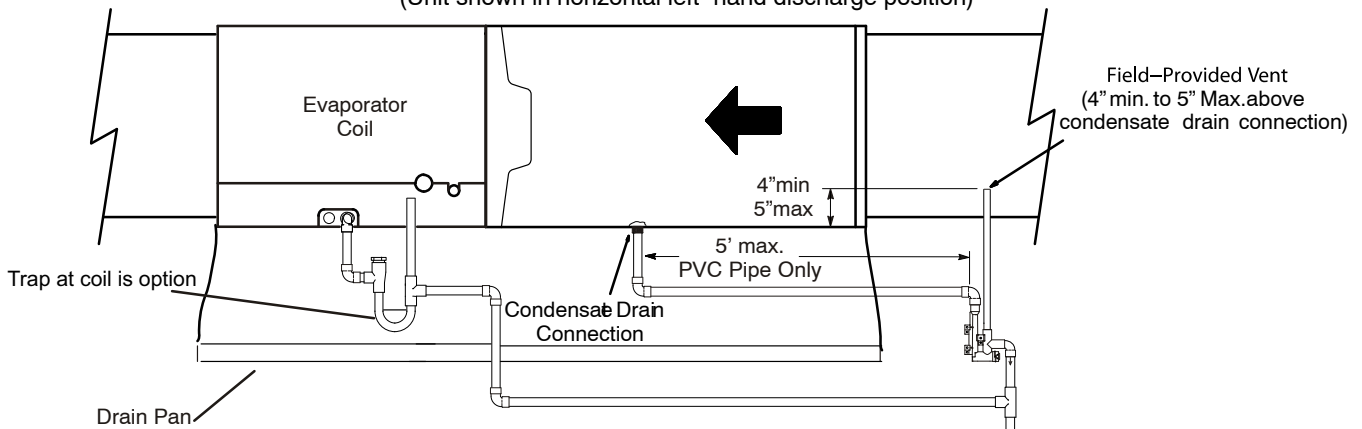

Piping from furnace and evaporator coil must slope down a minimum 1/4" per ft. toward trap

FIGURE 42

**TRAP / DRAIN ASSEMBLY USING 1/2" PVC OR 3/4" PVC
COLD END HEADER BOX WITH 3/4" DRAIN CONNECTION**

Optional Condensate Drain Connection

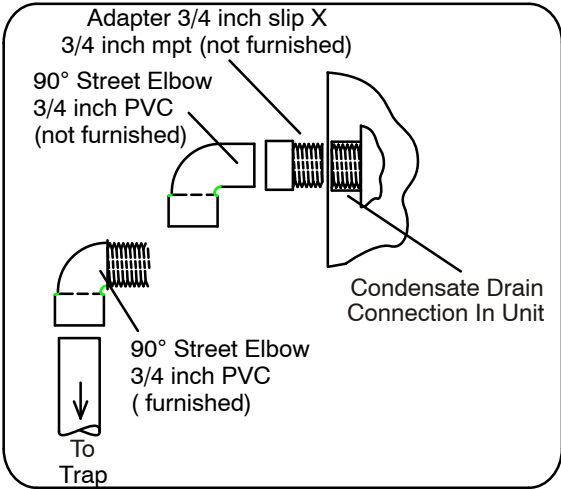

Optional Drain Piping From Trap

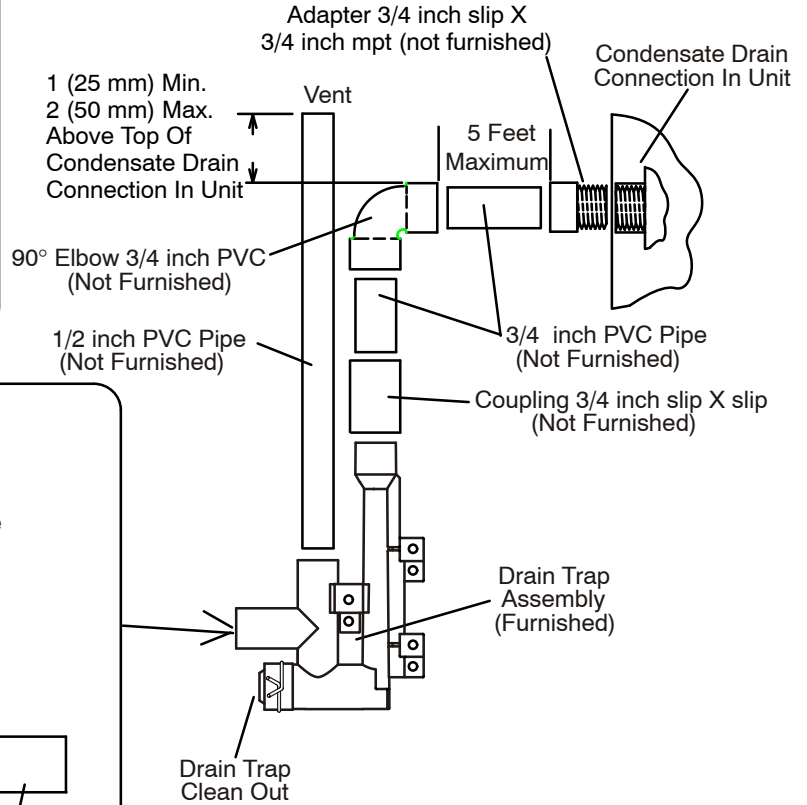
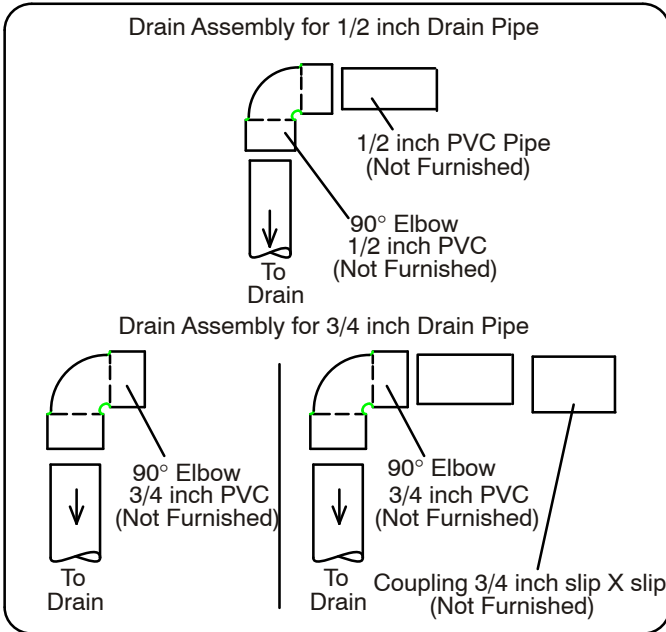

Drain Trap Assembly with 1/2 inch Piping

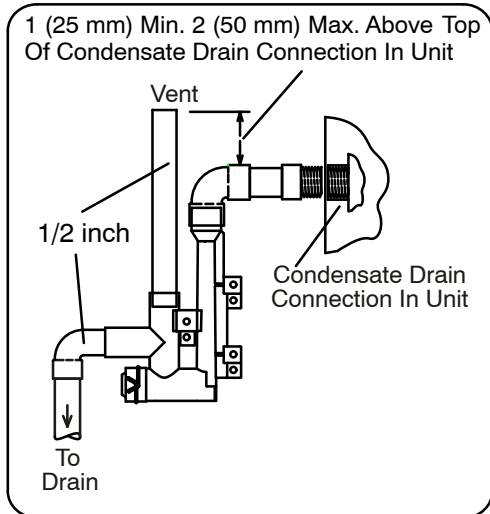

Drain Trap Assembly with 3/4 inch Piping

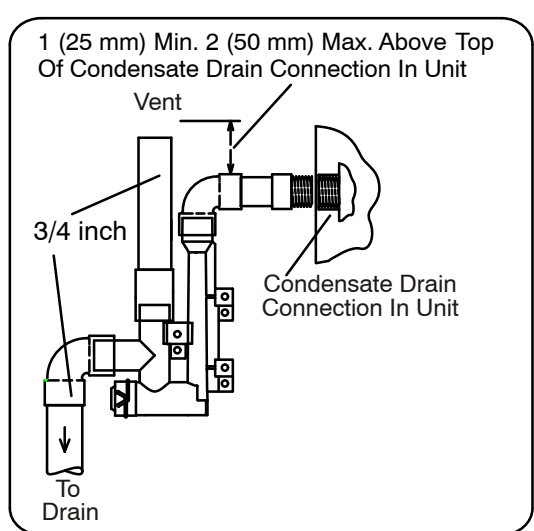

Drain Trap Assembly
(Furnished)

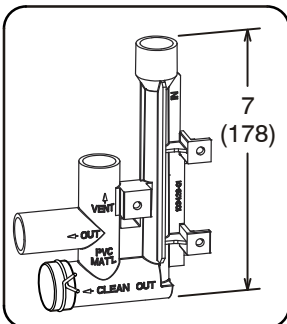

FIGURE 43

III-START-UP

A-Preliminary and Seasonal Checks

- 1 - Inspect electrical wiring, both field and factory installed for loose connections. Tighten as required.
- 2 - Check voltage at disconnect switch. Voltage must be within range listed on the nameplate. If not, consult the power company and have voltage condition corrected before starting unit.
- 3 - Inspect condition of condensate traps and drain assembly. Disassemble and clean seasonally.

B-Heating Start-Up

BEFORE LIGHTING the unit, smell all around the furnace area for gas. Be sure to smell next to the floor because some gas is heavier than air and will settle on the floor.

The gas valve on the SL297UHNV is equipped with a gas control switch. Use only your hand to move the switch. Never use tools. If the the switch will not move by hand, replace the valve. Do not try to repair it. Force or attempted repair may result in a fire or explosion.

Placing the furnace into operation:

SL297UHNV units are equipped with a SureLight® ignition system. Do not attempt to manually light burners on this furnace. Each time the thermostat calls for heat, the burners will automatically light. The ignitor does not get hot when there is no call for heat on units with SureLight ignition system.

Priming Condensate Trap

The condensate trap should be primed with water prior to start-up to ensure proper condensate drainage. Either pour 10 fl. oz. (300 ml) of water into the trap, or follow these steps to prime the trap:

- 1 - Follow the lighting instructions to place the unit into operation.
- 2 - Set the thermostat to initiate a heating demand.
- 3 - Allow the burners to fire for approximately 3 minutes.
- 4 - Adjust the thermostat to deactivate the heating demand.
- 5 - Wait for the combustion air inducer to stop. Set the thermostat to initiate a heating demand and again allow the burners to fire for approximately 3 minutes.
- 6 - Adjust the thermostat to deactivate the heating demand and again wait for the combustion air inducer to stop. At this point, the trap should be primed with sufficient water to ensure proper condensate drain operation.

⚠ WARNING

If you do not follow these instructions exactly, a fire or explosion may result causing property damage, personal injury or death.

Gas Valve Operation (Figure 44)

- 1 - **STOP!** Read the safety information at the beginning of this section.
- 2 - Set the thermostat to the lowest setting.
- 3 - Turn off all electrical power to the unit.

- 4 - This furnace is equipped with an ignition device which automatically lights the burners. Do **not** try to light the burners by hand.
- 5 - Remove the upper access panel.
- 6 - Move gas valve switch to **OFF**. See figure 44.
- 7 - Wait five minutes to clear out any gas. If you then smell gas, **STOP!** Immediately call your gas supplier from a neighbor's phone. Follow the gas supplier's instructions. If you do not smell gas go to next step.
- 8 - Move gas valve switch to **ON**. See figure 44.

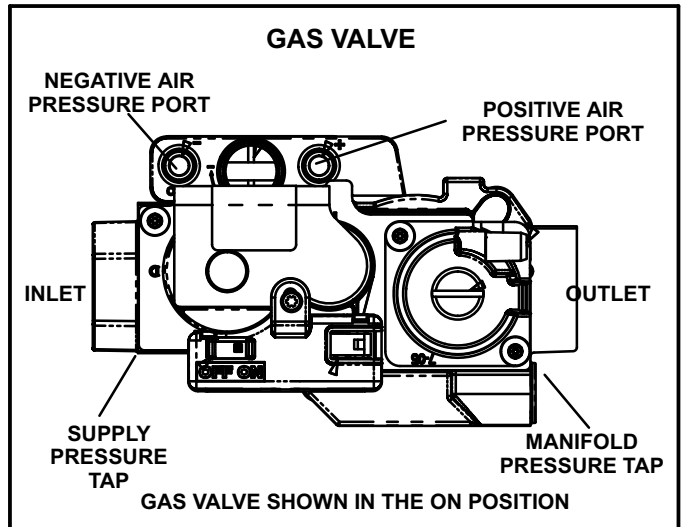

FIGURE 44

- 9 - Replace the upper access panel.
 - 10 - Turn on all electrical power to the unit.
 - 11 - Set the thermostat to desired setting.
- NOTE** - When unit is initially started, steps 1 through 11 may need to be repeated to purge air from gas line.
- 12 - If the appliance will not operate, follow the instructions "Turning Off Gas to Unit" and call your service technician or gas supplier.

Turning Off Gas to Unit

- 1 - Set the thermostat to the lowest setting.
- 2 - Turn off all electrical power to the unit if service is to be performed.
- 3 - Remove the upper access panel.
- 4 - Move gas valve switch to **OFF**.
- 5 - Replace the upper access panel.

Failure To Operate

If the unit fails to operate, check the following:

- 1 - Is the thermostat calling for heat?
- 2 - Are access panels securely in place?
- 3 - Is the main disconnect switch closed?
- 4 - Is there a blown fuse or tripped breaker?
- 5 - Is the filter dirty or plugged? Dirty or plugged filters will cause the limit control to shut the unit off.
- 6 - Is gas turned on at the meter?
- 7 - Is the manual main shut-off valve open?
- 8 - Is the internal manual shut-off valve open?
- 9 - Is the unit ignition system in lockout? If the unit locks out again, inspect the unit for blockages.

IV-HEATING SYSTEM SERVICE CHECKS

A-CSA Certification

All units are CSA design certified without modifications. Refer to the SL297UHNV Installation Instruction.

B-Gas Piping

⚠ CAUTION

If a flexible gas connector is required or allowed by the authority that has jurisdiction, black iron pipe shall be installed at the gas valve and extend outside the furnace cabinet.

⚠ WARNING

Do not over torque (800 in-lbs) or under torque (350 in-lbs) when attaching the gas piping to the gas valve.

Gas supply piping should not allow more than 0.5"W.C. drop in pressure between gas meter and unit. Supply gas pipe must not be smaller than unit gas connection.

Compounds used on gas piping threaded joints should be resistant to action of liquefied petroleum gases.

C-Testing Gas Piping

⚠ IMPORTANT

In case emergency shutdown is required, turn off the main shut-off valve and disconnect the main power to unit. These controls should be properly labeled by the installer.

When pressure testing gas lines, the gas valve must be disconnected and isolated. Gas valves can be damaged if subjected to more than 0.5 psig (14" W.C.). See figure 45. If the pressure is greater than 0.5psig (14"W.C.), use the manual shut-off valve before pressure testing to isolate furnace from gas supply.

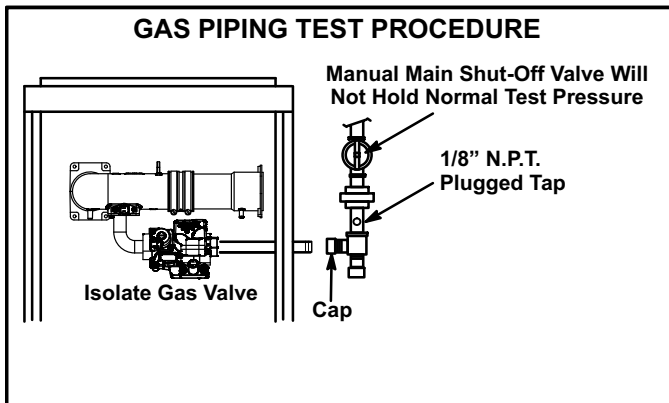

FIGURE 45

When checking piping connections for gas leaks, use preferred means. Kitchen detergents can cause harmful corrosion on various metals used in gas piping. Use of a specialty Gas Leak Detector is strongly recommended. It is available through Lennox under part number 31B2001. See Corp. 8411-L10, for further details.

Do not use matches, candles, flame or any other source of ignition to check for gas leaks.

D-Testing Gas Supply Pressure

A threaded plug on the inlet side of the gas valve provides access to the supply pressure tap. Remove the threaded plug, install a field-provided barbed fitting and connect a manometer to measure supply pressure. Replace the threaded plug after measurements have been taken. See table 26 for supply line pressure.

E- Proper Gas Flow (Approximate)

Furnace should operate at least 5 minutes before checking gas flow. Determine time in seconds for **two** revolutions of gas through the meter. (Two revolutions assures a more accurate time.) **Divide by two** and compare to time in table 25 below. If manifold pressure matches table 25 and rate is incorrect, check gas orifices for proper size and restriction.

NOTE- To obtain accurate reading, shut off all other gas appliances connected to meter.

TABLE 25

GAS METER CLOCKING CHART				
SL297 Model	Seconds for One Revolution			
	Natural		LP/Propane	
	1 cu ft Dial	2 cu ft Dial	1 cu ft Dia	2 cu ft Dial
040	90	180	N/A	N/A
060	60	120	150	300
080	45	90	112	224
Natural-1000 btu/cu f LP/Propane - 2500 btu/cuf				

TABLE 26

Manifold and Supply Line and LP Conversion Kits*

Unit	Fuel	Supply Line Pressure in. w.g.	
		Min	Max
All Sizes	Nat	4.5	10.5
-040	LP	N/A	N/A
-060*		11.0	13.0
-080*			

Manifold and Signal Pressure Measurement

To correctly measure manifold and signal pressure, follow the steps below:

- 1 - Turn off the electrical power and gas supply to the furnace.
- 2 - Remove the threaded plug from the outlet side of the gas valve and install a field-provided barbed fitting. Connect measuring device positive "+" to barbed fitting to measure manifold pressure. See figure 44 for manifold location.
- 3 - Install hoses and meter as shown in figure 48 for signal pressure measurement.
- 4 - Start unit on low fire and after allowing unit to stabilize for **8 minutes**, record manifold pressure and compare to value in table 27. Repeat on high fire. If manifold pressure is within range, rate check is complete move to step 6. If manifold pressure is not within range continue.

Valve is not adjustable. Do not adjust manifold pressure.

- 5 - Record signal pressure and compare to value in table 27. If signal pressure is within range continue. If the signal is not within range go to "Troubleshooting".
- 6 - Shut off unit and remove manometer and signal meter after accurate readings has been obtained.
- 7 - Restart unit and check for gas leaks. Seal any leaks found.

If the unit has difficulty igniting or ignites with loud resonance the air orifice must be checked and replaced if necessary.

Air Orifice Replacement

Do not replace the air orifice until the problem has been determined. If the unit has difficulty igniting the orifice is oversized and brings in too much air. If the unit ignites but with loud resonance the orifice is too small and needs more air. The air orifice is located inside the gray coupling between the clamps. Figure 47 show corresponding steps with the steps below.

- 1 - Turn off the electrical power and gas supply to the furnace.
- 2 - Remove the black air pressure tube on the air intake coupling.
- 3 - Use a 5/16" nut driver to loosen the clamps on the gray coupling.
- 4 - Remove the two screws attaching the air intake coupling to the furnace cabinet.
- 5 - Remove the air intake coupling. If the air intake coupling is still too difficult to remove, then remove the two screws from the right side of the top cap and one from the far right side of the blower deck that attaches to the cabinet. See figure 46. Carefully pull cabinet side away from air intake coupling, then remove the air intake coupling. **Note: Be careful not to bend the cabinet side.**
- 6 - Remove the air orifice. Check the "Part" number stamped on the air orifice. See table 28. If the part number is incorrect, then replace it with the proper air orifice. Repeat manifold check. If air orifice is correct diameter, then it must be replaced to resolve ignition or resonance issue. See table 28 for replacement.
- 7 - Reinstall the air orifice on the left side of the coupling and push firmly into place.
- 8 - Reinstall air intake coupling making sure it is fully seated in the gray coupling. Re-install the two screws attaching the air intake coupling to the furnace cabinet. Tighten clamps to secure the coupling. Re-install the two screws on the right side of the top cap and the one screw that attaches the blower deck to the cabinet.
- 9 - Reconnect the black air pressure tube.
- 10 - Repeat manifold and signal pressure check. If unit ignites and manifold and signal pressure are correct, move on to combustion check. If unit still does not ignite or ignites with loud resonance go to Troubleshooting figure 49.

TABLE 27

Altitude	Unit	Manifold Natural wc		Manifold LP/Propane wc		Signal Pressure	
		High Fire	Low Fire	High Fire	Low Fire	High Fire	Low Fire
0-4500ft	-040	3.2 - 3.8	1.4 - 2.0	N/A	N/A	0.80 - 0.93	0.32 - 0.42
	-060 ¹			3.6	1.7	0.69 - 0.93	0.28 - 0.42
	-080 ²					0.73 - 0.93	0.30 - 0.40
4501-7500ft	-040	N/A	N/A	N/A	N/A	N/A	N/A
	-060 ¹	2.3	1.2	2.5	1.2	0.55 - 0.65	0.28 - 0.36
	-080 ²	2.4	1.2	2.8	1.3	0.58 - 0.73	0.28 - 0.36

1 -060 uses LP kit 19K05

2 -080 uses LP kit 19K06

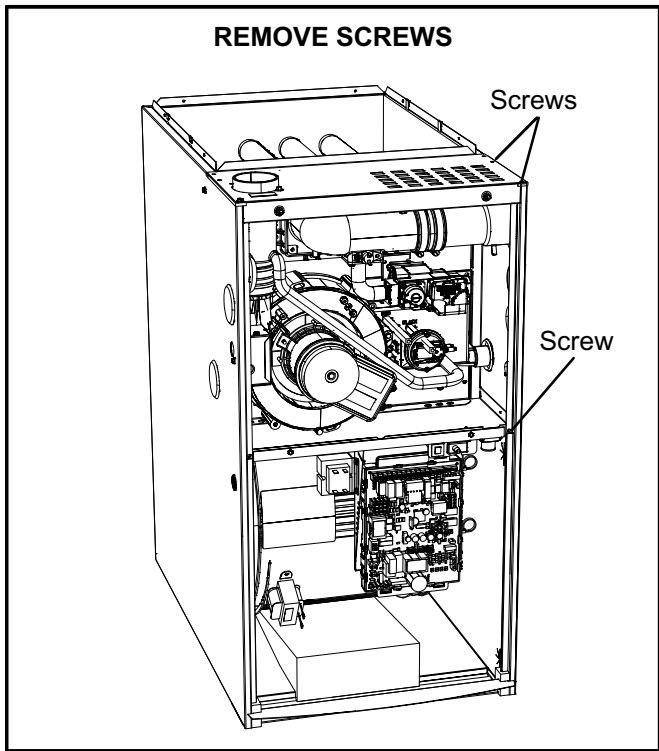

FIGURE 46

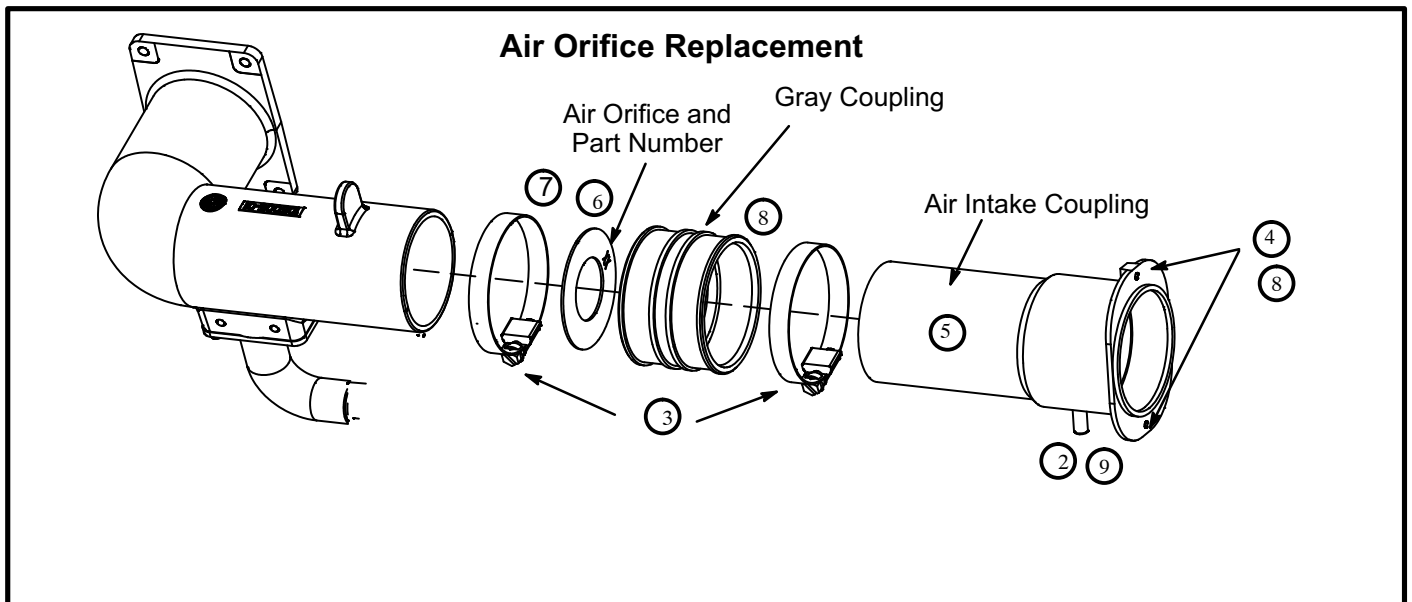

FIGURE 47

Operating Signal Pressure Measurement

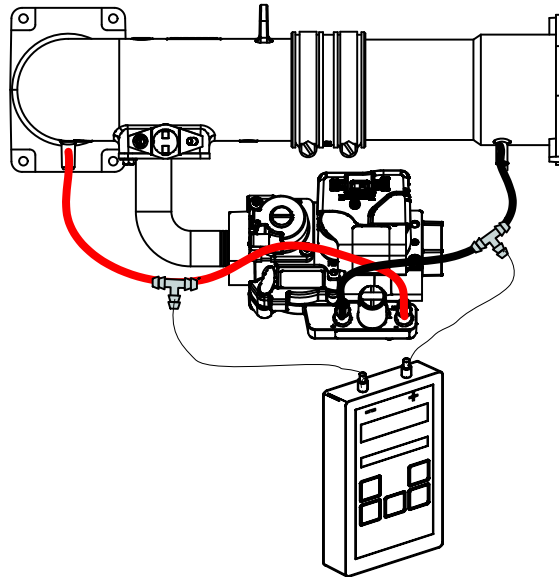

FIGURE 48

TABLE 28

Unit	Production	Resonance (more air)		Difficulty Igniting (less air)	
	Orifice Size (Part No)	Orifice Size	Cat No	Orifice Size	Cat No
040	0.800 (16)	0.812 (01)	21U23	0.787 (20)	21U01
060	0.995 (14)	1.010 (21)	21U02	0.980 (13)	21U25
080	1.105 (12)	1.125 (03)	19X31	1.085 (22)	21U03

Troubleshooting Poor Ignition or Combustion Resonance Issues

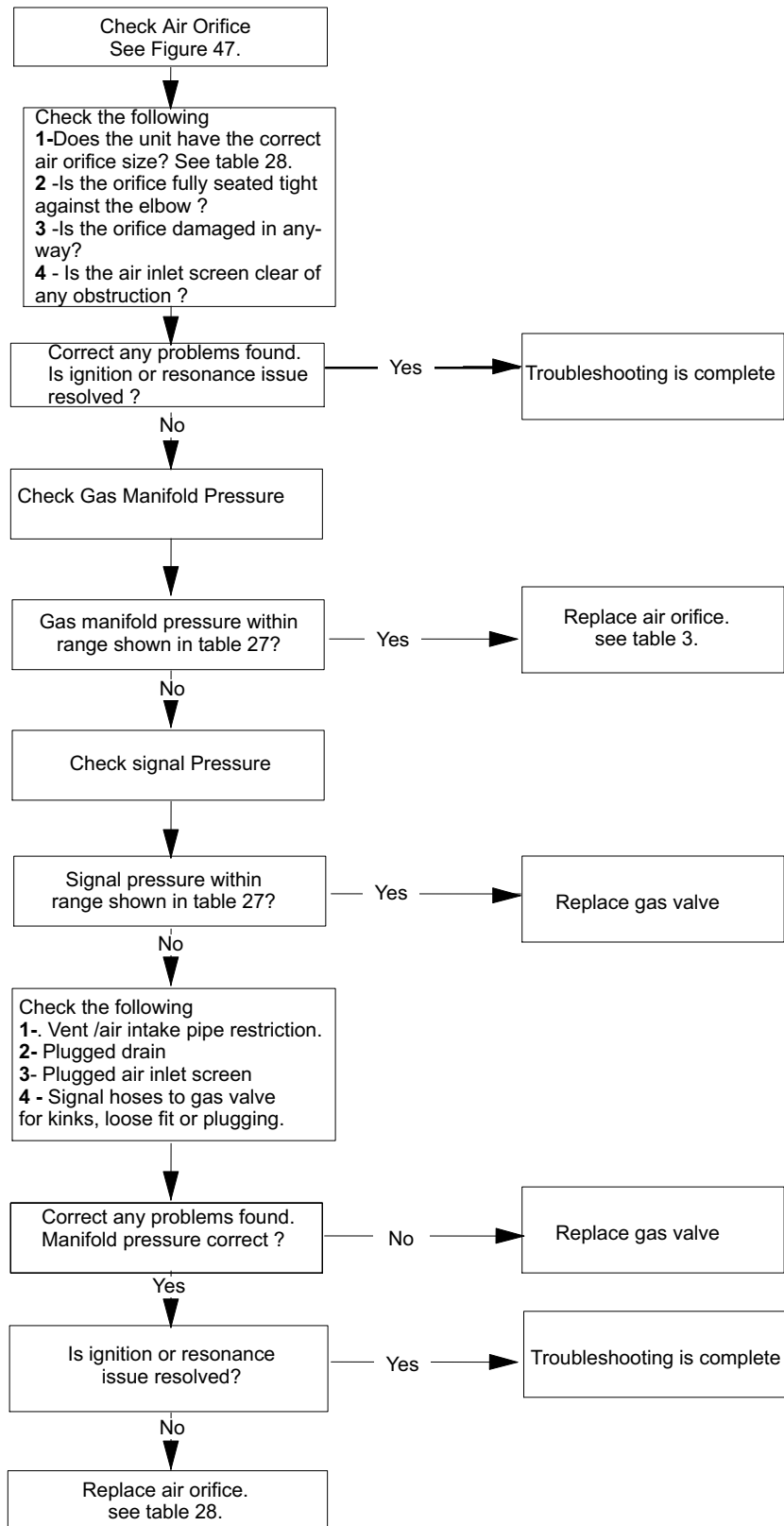

FIGURE 49

⚠ IMPORTANT

For safety, shut unit off and remove manometer as soon as an accurate reading has been obtained. Take care to replace pressure tap plug.

F- Proper Combustion

Furnace should operate minimum 15 minutes with correct manifold pressure and gas flow rate before checking combustion. Take combustion sample beyond the flue outlet. Table 29 shows acceptable combustions.

TABLE 29

SL297 Model	CO ₂ % For Nat		CO ₂ % For LP	
	Low Fire	High Fire	Low Fire	High Fire
040	6.3 - 7.8	6.3 - 7.8	N/A	N/A
060	6.5 - 8.2	6.5 - 8.2	9.3 - 10.0	9.3 - 10.0
080	7.2 - 8.4	7.2 - 8.4	9.5 - 10.2	9.5 - 10.2

The maximum carbon monoxide reading should not exceed 100ppm.

G- High Altitude

Units are **NOT** approved for installations over 4500 ft

H- Proper Ground and Voltage

A poorly grounded furnace can contribute to premature ignitor failure. Use the following procedure to check for ground and voltage to the integrated control.

- 1 - Measure the AC voltage between Line Neutral (spade terminals) and "C" terminal (low voltage terminal block) on the integrated control. See figure 50. A wide variation in the voltage between Line Neutral and "C" as a function of load indicates a poor or partial ground. Compare the readings to the table below. If the readings exceed the maximum shown in table 1, make repairs before operating the furnace.
- 2 - In addition, measure the AC voltage from Line Hot to Line Neutral (spade terminals) on the integrated control. See figure 50. This voltage should be in the range of 97 to 132 Vac

TABLE 30

Furnace Status	Measurement VAC	
	Expected	Maximum
Power On Furnace Idle	0.3	2
CAI / Ignitor Energized	0.75	5
Indoor Blower Energized	Less than 2	10

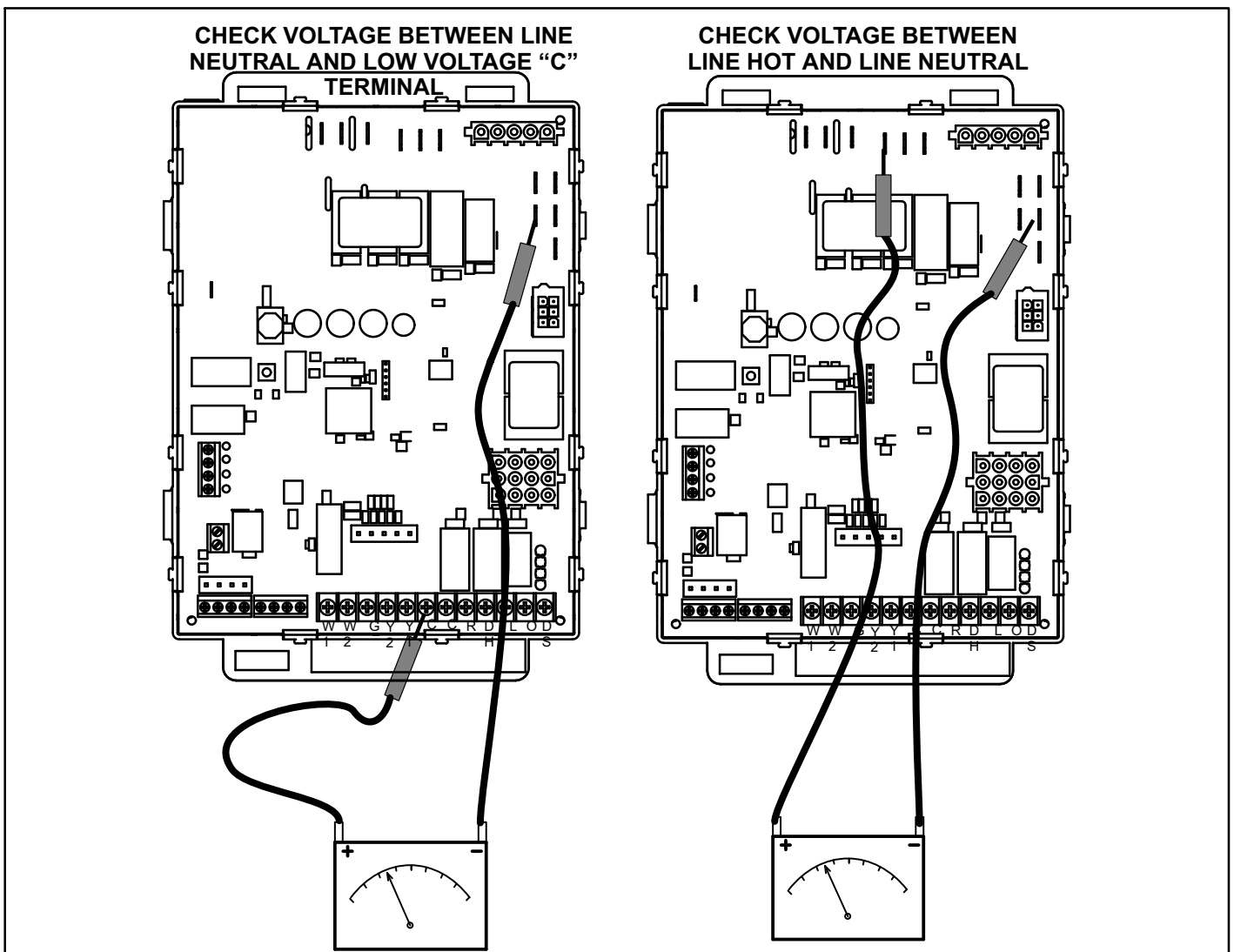

FIGURE 50

V-TYPICAL OPERATING CHARACTERISTICS

A-Blower Operation and Adjustment

- 1 - Blower operation is dependent on thermostat control system.
- 2 - Generally, blower operation is set at thermostat sub-base fan switch. With fan switch in ON position, blower operates continuously. With fan switch in AUTO position, blower cycles with demand or runs continuously while heating or cooling circuit cycles.
- 3 - Depending on the type of indoor thermostat, blower and entire unit will be off when the system switch is in OFF position.

B-Temperature Rise (Figure 51)

Temperature rise for SL297UHNV units depends on unit input, blower speed, blower horsepower and static pressure as marked on the unit rating plate. The blower speed must be set for unit operation within the range of "TEMP. RISE °F" listed on the unit rating plate.

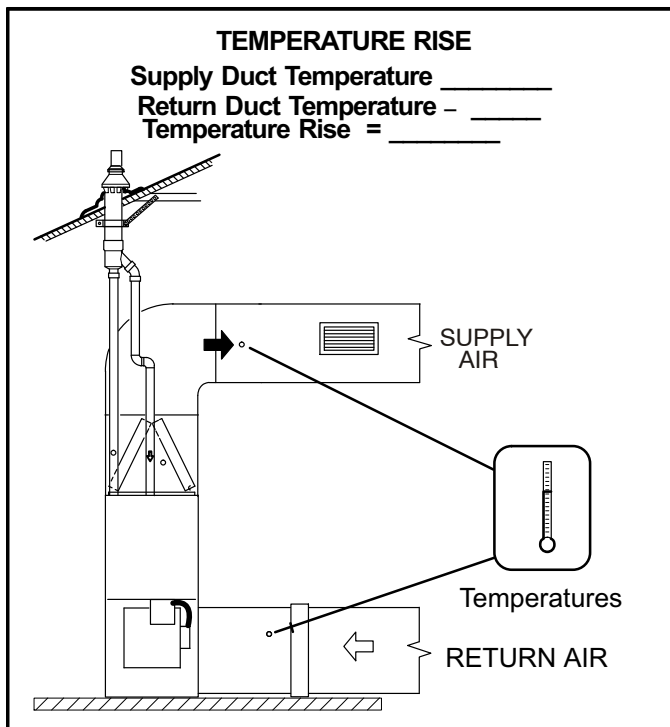

FIGURE 51

C-External Static Pressure

- 1 - Tap locations shown in figure 52.
- 2 - Punch a 1/4" diameter hole in supply and return air plenums. Insert manometer hose flush with inside edge of hole or insulation. Seal around the hose with permagum. Connect the zero end of the manometer to the discharge (supply) side of the system. On ducted systems, connect the other end of manometer to the return duct as above.
- 3 - With only the blower motor running and the evaporator coil dry, observe the manometer reading. Adjust blower motor speed to deliver the air desired according to the job requirements. For heating speed (second stage heat speed) external static pressure drop must not be more than 0.8" W.C. For cooling speed (second stage cool speed) external static pressure drop must not be more than 1.0" W.C.
- 4 - Seal the hole when the check is complete.

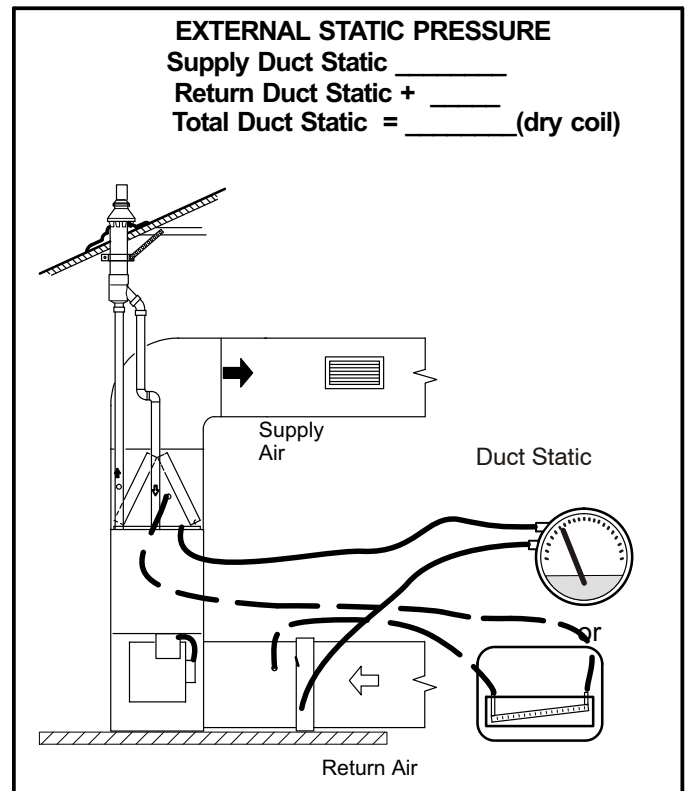

FIGURE 52

VI-MAINTENANCE

⚠ WARNING

**ELECTRICAL SHOCK, FIRE,
OR EXPLOSION HAZARD.**

Failure to follow safety warnings exactly could result in dangerous operation, serious injury, death or property damage.

Improper servicing could result in dangerous operation, serious injury, death, or property damage.

Before servicing, disconnect all electrical power to furnace.

When servicing controls, label all wires prior to disconnecting. Take care to reconnect wires correctly. Verify proper operation after servicing.

At the beginning of each heating season, system should be checked as follows by a qualified service technician:

Blower

Check the blower wheel for debris and clean if necessary. The blower motors are prelubricated for extended bearing life. No further lubrication is needed.

⚠ WARNING

The blower access panel must be securely in place when the blower and burners are operating. Gas fumes, which could contain carbon monoxide, can be drawn into living space resulting in personal injury or death.

Filters

All air filters are installed external to the unit. Filters should be inspected monthly. Clean or replace the filters when necessary to ensure proper furnace operation. Table 31 lists recommended filter sizes.

IMPORTANT

If a high-efficiency filter is being installed as part of this system to ensure better indoor air quality, the filter must be properly sized. High-efficiency filters have a higher static pressure drop than standard-efficiency glass/foam filters. If the pressure drop is too great, system capacity and performance may be reduced. The pressure drop may also cause the limit to trip more frequently during the winter and the indoor coil to freeze in the summer, resulting in an increase in the number of service calls.

Before using any filter with this system, check the specifications provided by the filter manufacturer against the data given in the appropriate Lennox Product Specifications bulletin. Additional information is provided in Service and Application Note ACC-00-2 (August 2000).

TABLE 31

Furnace Cabinet Width	Filter Size	
	Side Return	Bottom Return
17-1/2"	16 X 25 X 1 (1)	16 X 25 X 1 (1)
21"	16 X 25 X 1 (1)	20 X 25 X 1 (1)

Exhaust and air intake pipes

Check the exhaust and air intake pipes and all connections for tightness and to make sure there is no blockage.

NOTE - After any heavy snow, ice or frozen fog event the furnace vent pipes may become restricted. Always check the vent system and remove any snow or ice that may be obstructing the plastic intake or exhaust pipes.

Electrical

- 1 - Check all wiring for loose connections.
- 2 - Check for the correct voltage at the furnace (furnace operating).
- 3 - Check amp-draw on the blower motor.
Motor Nameplate _____ Actual _____

Winterizing and Condensate Trap Care

- 1 - Turn off power to the furnace.
- 2 - Have a shallow pan ready to empty condensate water.
- 3 - Remove the clean out cap from the condensate trap and empty water. Inspect the trap then reinstall the clean out cap.

Cleaning the Heat Exchanger and Burner figure 53

If cleaning the heat exchanger becomes necessary, follow the below procedures and refer to figure 1 and 53 when disassembling unit. Use papers or protective covering in front of furnace while removing heat exchanger assembly.

- 1 - Turn off both electrical and gas power supplies to furnace.
- 2 - Remove exhaust pipe from appliance adaptor but leave adaptor connected to exhaust coupling. Remove top cap and intake air pipe from side of unit.
- 3 - Label the wires from gas valve, thermal switch, primary limit switch and make-up box then disconnect them.
- 4 - Label then disconnect the wires from gas valve, thermal switch, primary limit switch and make-up box.
- 5 - Disconnect gas supply piping. Remove the screw securing the air fuel plenum and remove along with the air intake assembly as one component.
- 6 - Remove screws from both sides, top and bottom of vestibule panel.
- 7 - Remove heat exchanger. It may be necessary to spread cabinet side to allow more room.
- 8 - Back wash using steam. Begin from the burner opening on each tube. Steam must not exceed 275°F.
- 9 - Run a vacuum cleaner over the face of burner. Visually inspect inside the burner. Remove any blockage. Replace gasket between burner plate and air fuel plenum then re-install burner plate.
- 10 - To clean the combustion air inducer visually inspect and using a wire brush clean where necessary. Use compressed air to clean off debris and any rust.
- 11 - Reinstall heat exchanger in vestibule.
- 12 - Reinstall the air fuel plenum and air intake assembly.
- 13 - Re-install the combustion air inducer assembly. Make note to re-install all screws. Failure to replace all screws may cause leaks. Reconnect all wires.
- 14 - Reconnect top cap and exhaust pipe to combustion air inducer outlet. Reconnect intake air pipe.
- 15 - Reconnect gas supply piping.
- 16 - Turn on power and gas supply to unit.
- 17 - Set thermostat and check for proper operation.
- 18 - Check all piping connections, factory and field, for gas leaks. Use a leak detecting solution or other preferred means.

CAUTION

Some soaps used for leak detection are corrosive to certain metals. Carefully rinse piping thoroughly after leak test has been completed. Do not use matches, candles, flame or other sources of ignition to check for gas leaks.

- 19 - If a leak is detected, shut gas and electricity off and repair leak.
- 20 - Repeat steps 18 and 19 until no leaks are detected..
- 21 - Replace access panel.

SL297UHNV HEATING COMPONENTS

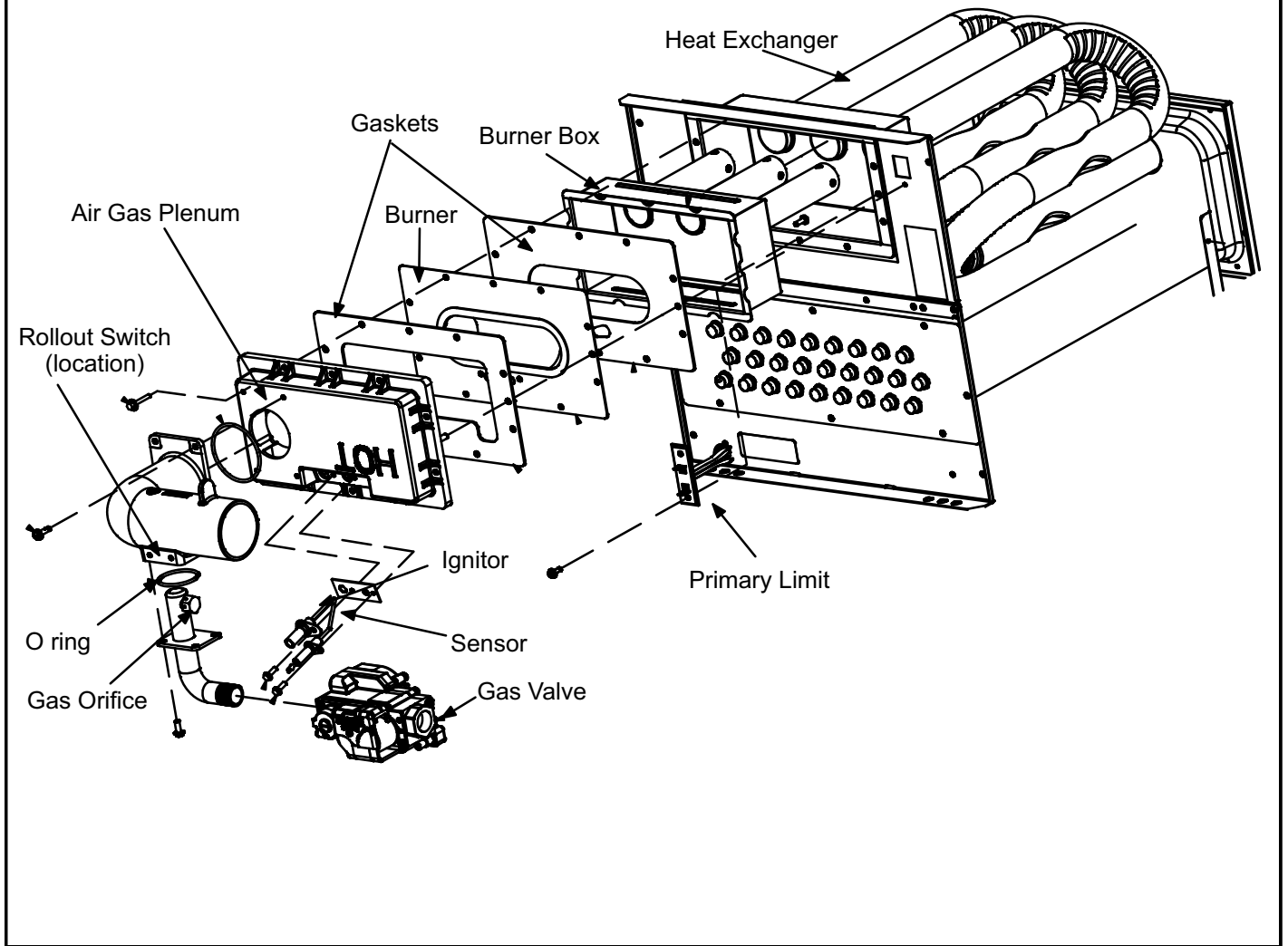
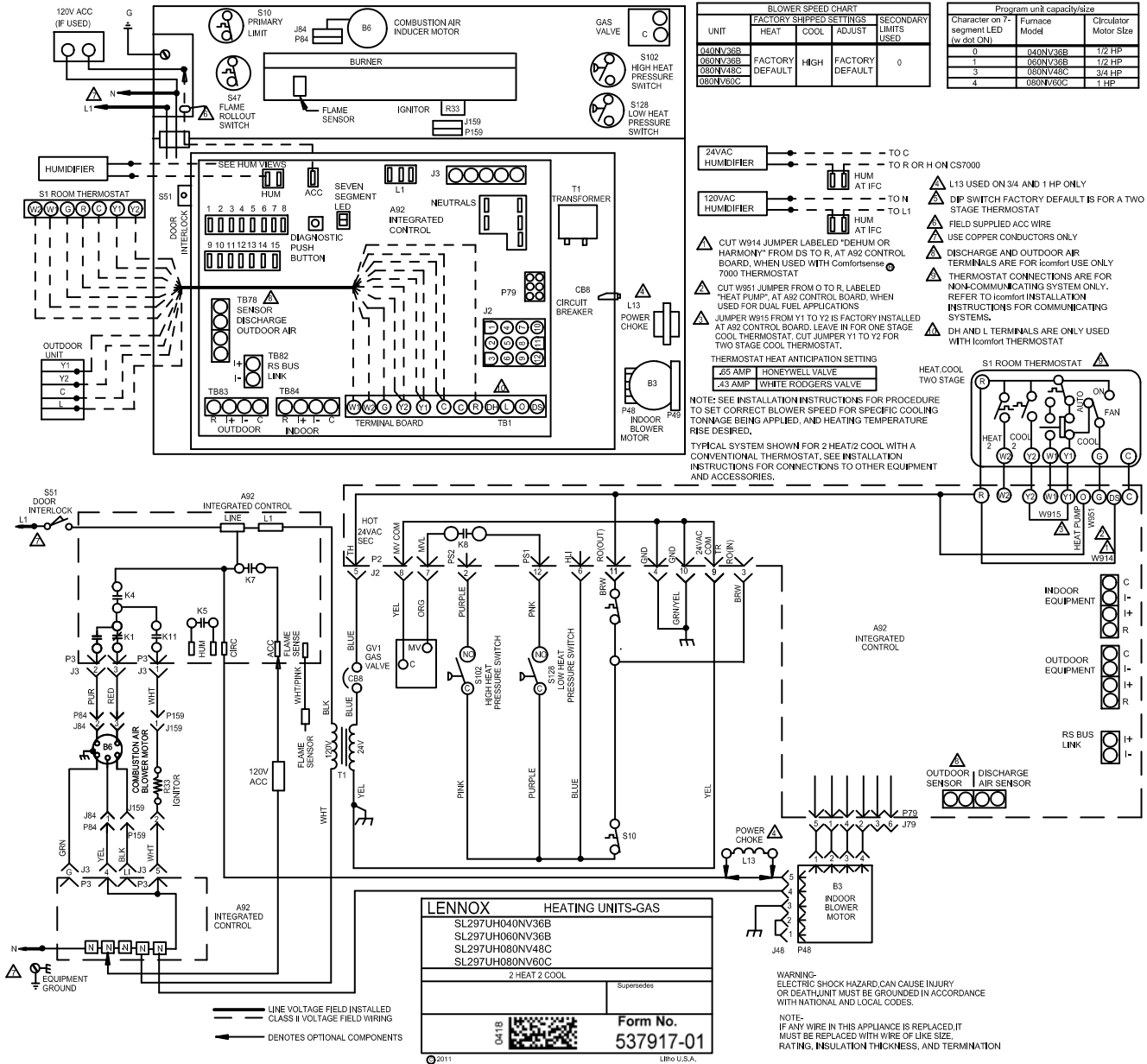

FIGURE 53

VII- Wiring and Sequence of Operation

SL297UHNV Schematic Wiring Diagram



CAUTION

Failure to use properly sized wiring and circuit breaker may result in property damage. Size wiring and circuit breaker(s) per Product Specifications bulletin (EHB) and unit rating plate.

WARNING

Fire Hazard. Use of aluminum wire with this product may result in a fire, causing property damage, severe injury or death. Use copper wire only with this product.

WARNING



Electric Shock Hazard. Can cause injury or death. Unit must be properly grounded in accordance with national and local codes.

Electronic Ignition

The two-stage, variable speed integrated control used in SL297UHNV units has an added feature of an internal Watchguard control. The feature serves as an automatic reset device for ignition control lockout caused by ignition failure. After one hour of continuous thermostat demand for heat, the Watchguard will break and remake thermostat demand to the furnace and automatically reset the control to begin the ignition sequence.

NOTE - The ignition control thermostat selection DIP switch is factory-set in the "TWO-STAGE" position.

Applications Using a Two-Stage Thermostat See figure 54 for ignition control sequence

A - Heating Sequence -- Integrated Control Thermostat Selection DIP Switch 1 OFF in "Two-Stage" Position (Factory Setting)

1. On a call for heat, thermostat first-stage contacts close sending a signal to the integrated control. The integrated control runs a self-diagnostic program and checks high temperature limit switches for normally closed contacts and pressure switches for normally open contacts. The combustion air inducer is energized at low speed.
2. Once the control receives a signal that the low pressure switch has closed, the combustion air inducer begins a 15-second pre-purge in low speed.

NOTE - If the low fire pressure switch does not close

the combustion air inducer will switch to high fire. After a 15 second pre-purge the high fire pressure switch will close and the unit will begin operation on high fire. After 10 to 20 seconds of high fire operation the unit will switch to low fire..

3. After the pre-purge is complete, a 20-second initial ignitor warm-up period begins. The combustion air inducer continues to operate at low speed.
- 4 - After the 20-second warm-up period has ended, the gas valve is energized on low fire (first stage) and ignition occurs. At the same time, the control module sends a signal to begin an indoor blower 30-second ON-delay. When the delay ends, the indoor blower motor is energized on the low fire heating speed, the HUM contacts close energizing the humidifier and 120V ACC terminal is energized. The furnace will continue this operation as long as the thermostat has a first-stage heating demand.
- 5 - If second-stage heat is required, the thermostat second-stage heat contacts close and send a signal to the integrated control. The integrated control initiates a 30-second second-stage recognition delay.
NOTE - If the indoor thermostat is set on CONTINUOUS FAN ON mode, the furnace will light on high fire (second-stage) for 60 seconds to improve heat exchanger warm up. After 60 second warm-up period, furnace will switch to low fire (first-stage).
- 6 - At the end of the recognition delay, the integrated control energizes the combustion air inducer at high speed. The control also checks the high fire (second stage) pressure switch to make sure it is closed. The high fire (second stage) gas valve is energized and the indoor blower motor is energized for operation at the high fire heating speed.
- 7 - When the demand for high fire (second stage) heat is satisfied, the combustion air inducer is switched to the low-fire heating speed and the high-fire (second stage) gas valve is de-energized. The low-fire (first stage) gas valve continues operation. The indoor blower motor is switched to the low-fire heating speed.
- 8 - When the thermostat demand for low-fire (first stage) heat is satisfied, the gas valve is de-energized and the field-selected indoor blower off delay begins. The combustion air inducer begins a 5-second post-purge period.
- 9 - When the combustion air post-purge period is complete, the inducer, the HUM contacts as well as the 120V ACC terminals are de-energized. The indoor blower is de-energized at the end of the off delay.

Applications Using A Single-Stage Thermostat
See figure 55 for ignition control sequence

B - Heating Sequence -- Integrated Control Thermostat Selection DIP Switch 1 ON in "Single-Stage" Position

NOTE - In these applications, two-stage heat will be initiated by the integrated control if heating demand has not been satisfied after the field adjustable period (7 or 12 minutes).

1. On a call for heat, thermostat first-stage contacts close sending a signal to the integrated control. The integrated control runs a self-diagnostic program and checks high temperature limit switches for normally closed contacts and pressure switches for normally open contacts. The combustion air inducer is energized at low speed.
2. Once the control receives a signal that the low pressure switch has closed, the combustion air inducer begins a 15-second pre-purge in low speed.
NOTE - If the low fire pressure switch does not close the combustion air inducer will switch to high fire. After a 15 second pre-purge the high fire pressure switch will close and the unit will begin operation on high fire. After 10 to 20 seconds of high fire operation the unit will switch to low fire.
3. After the pre-purge is complete, a 20-second initial ignitor warm-up period begins. The combustion air inducer continues to operate at low speed.

- 4 - After the 20-second warm-up period has ended, the gas valve is energized on low fire (first stage) and ignition occurs. At the same time, the control module sends a signal to begin an indoor blower 30-second ON-delay. When the delay ends, the indoor blower motor is energized on the low fire heating speed and the HUM contacts are energized. The integrated control also initiates a second-stage on delay (factory-set at 7 minutes; adjustable to 12 minutes).
- 5 - If the heating demand continues beyond the second-stage on delay, the integrated control energizes the combustion air inducer at high speed. The control also checks the high fire (second stage) pressure switch to make sure it is closed. The high fire (second stage) gas valve is energized and the indoor blower motor is energized for operation at the high fire heating speed.
- 6 - When the thermostat heating demand is satisfied, the combustion air inducer begins a 5-second low speed post-purge. The field-selected indoor blower off delay begins. The indoor blower operates at the low-fire heating speed.
- 7 - When the combustion air post-purge period is complete, the inducer, the HUM contacts as well as the 120V ACC terminals are de-energized. The indoor blower is de-energized at the end of the off delay.

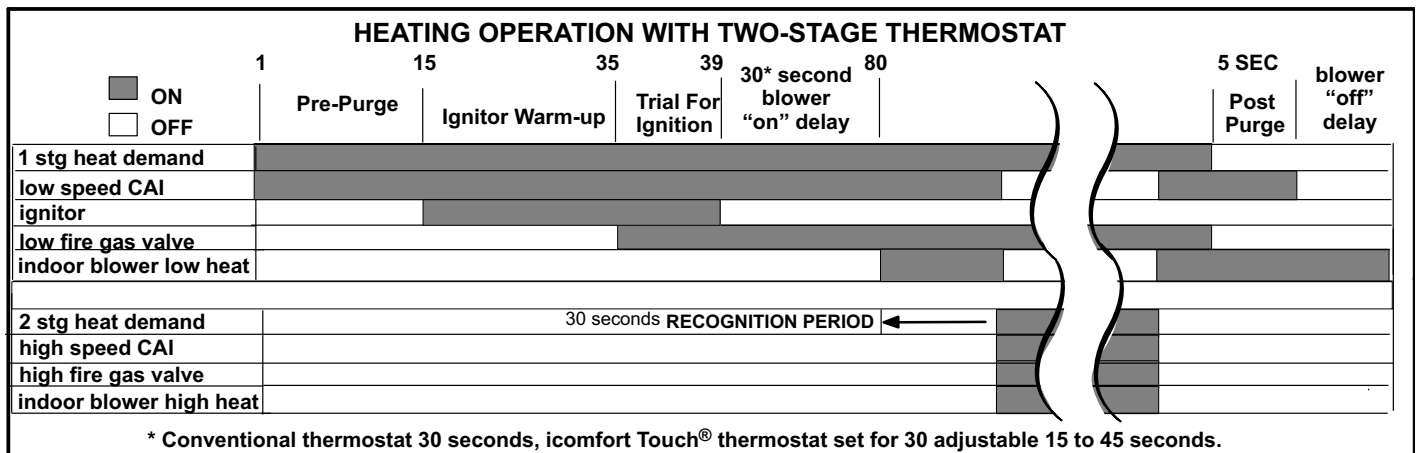

FIGURE 54

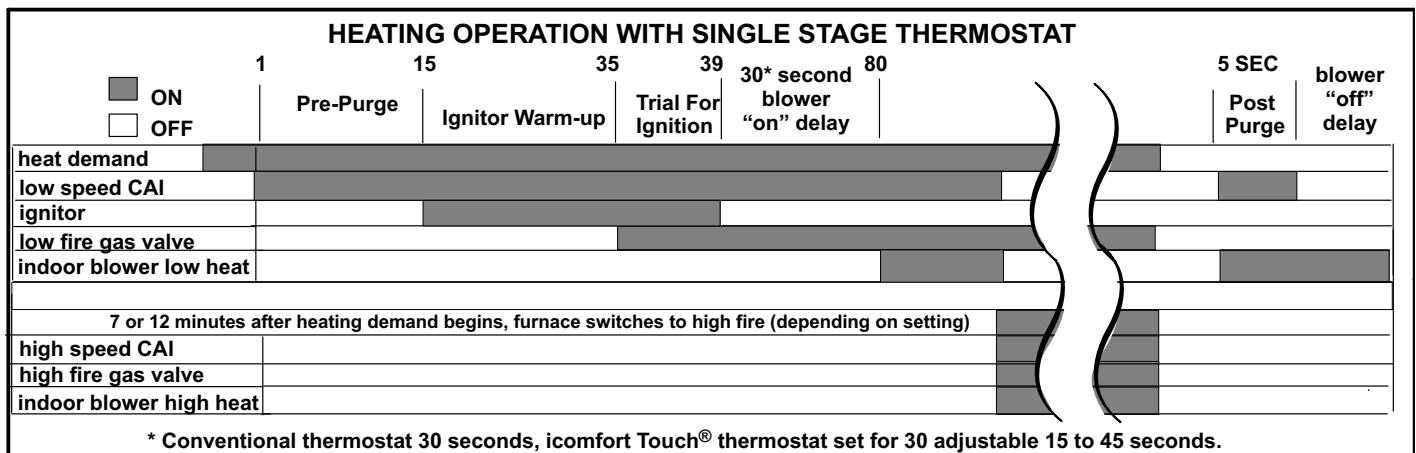
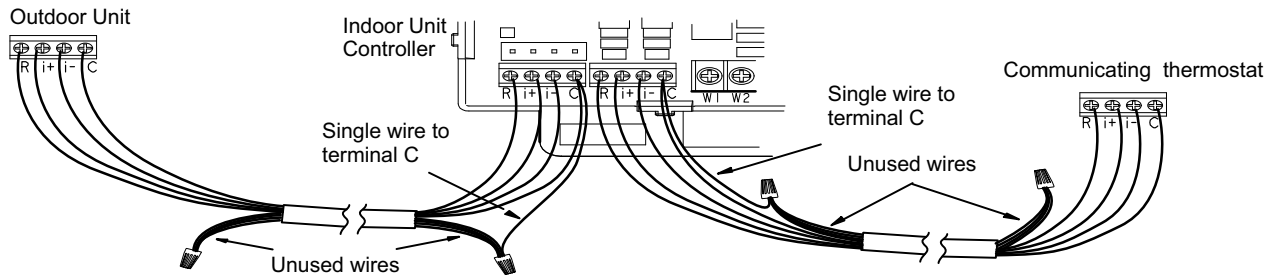
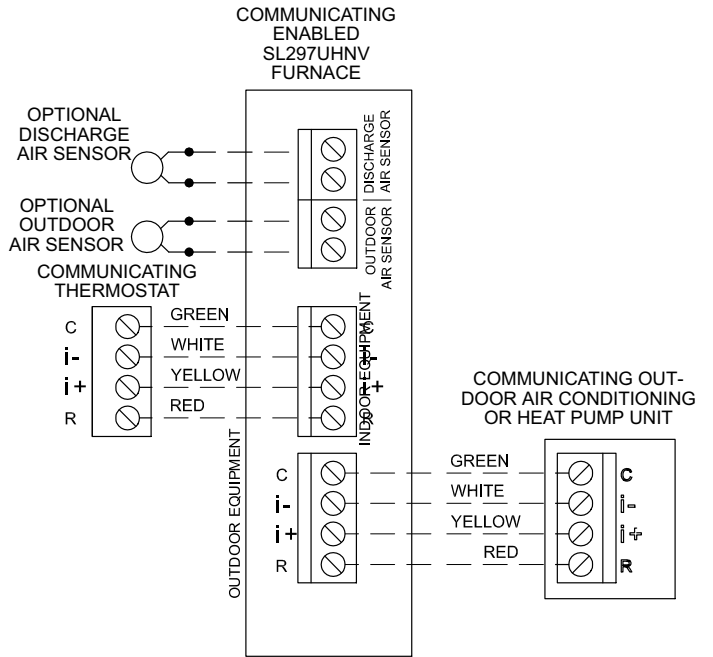
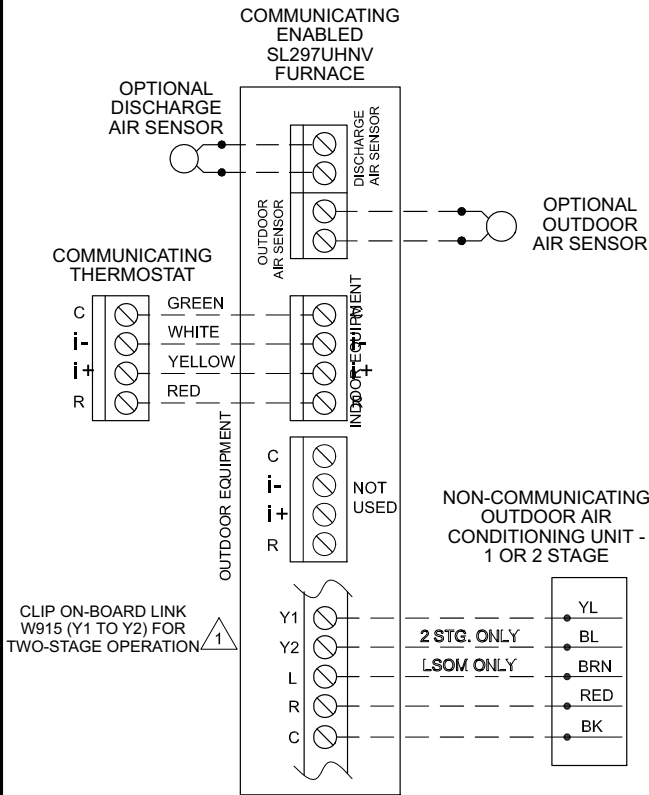

FIGURE 55

Communicating Thermostat with SL297UHNV and Non-Communicating Outdoor Unit

Communicating Thermostat with SL297UHNV and Communicating Outdoor Unit



Systems using a communicating thermostat require four thermostat wires between the thermostat and the furnace/air handler control and four wires between the outdoor unit and the furnace/air handler control. When a thermostat cable with more than four wires is used, the extra wires must be properly connected to avoid electrical noise. The wires must not be left disconnected.

Use wire nuts to bundle the four unused wires at each end of the cable. A single wire should then be connected to the indoor unit end of the wire bundle and attached to the "C" terminals as shown above.

FIGURE 56

Optional Accessories for use with any icomfort Touch® System

NOTE: ico Wi-Fi® THERMOSTAT SENSES HUMIDITY & CONTROLS HUM CONTACTS TO CYCLE HUMIDIFIER BASED ON DEMAND. NO OTHER CONTROL OR HUMIDISTAT REQUIRED. OPTIONAL OUTDOOR AIR SENSOR FOR USE WITH HUMIDIFIER (IF NOT ALREADY IN THE SYSTEM FOR OTHER FUNCTIONS. BUILT INTO ALL icomfort by Lennox™ OUTDOOR UNITS).

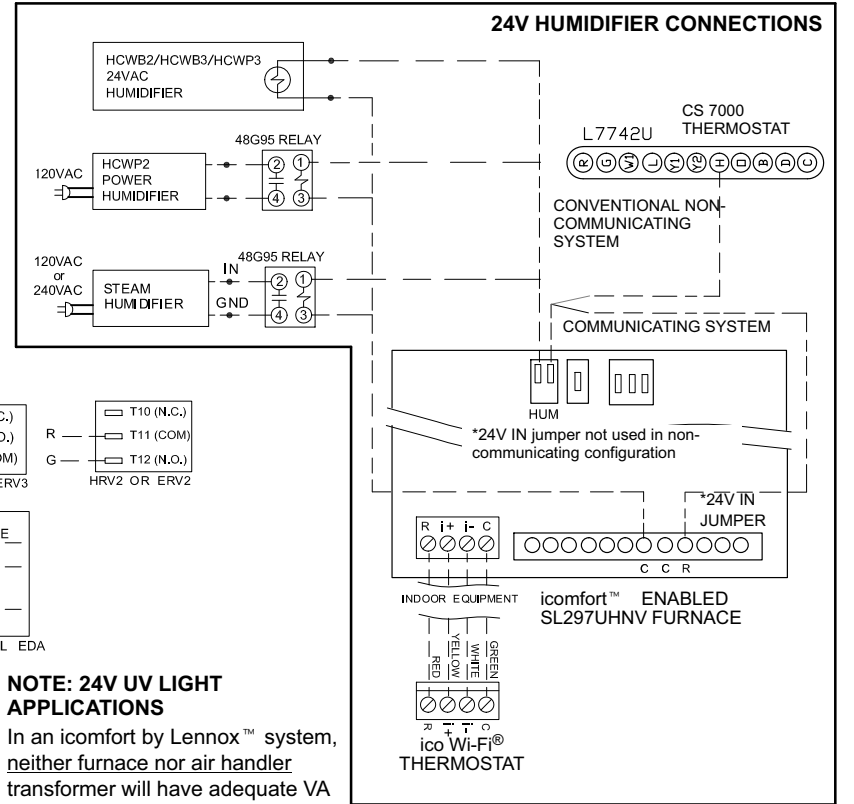
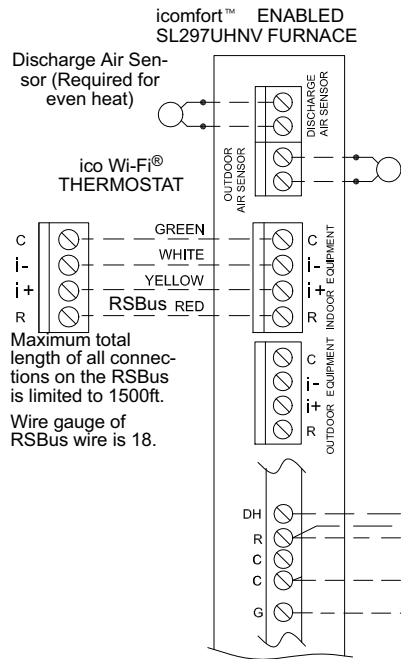
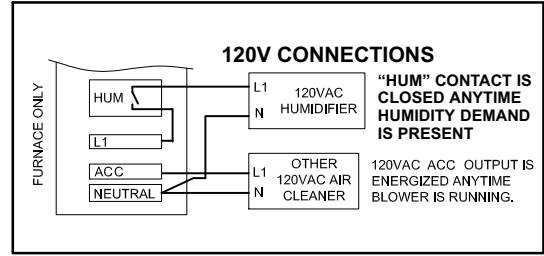

NOTE: 24V UV LIGHT APPLICATIONS

In an icomfort by Lennox™ system, neither furnace nor air handler transformer will have adequate VA to power 24V UV light applications. An additional transformer for UV light applications is required.

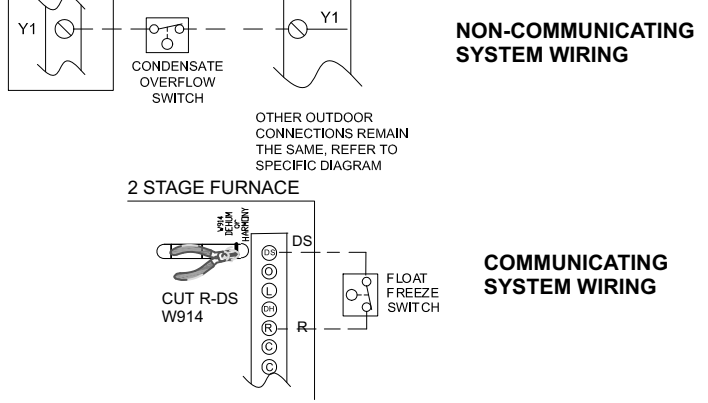
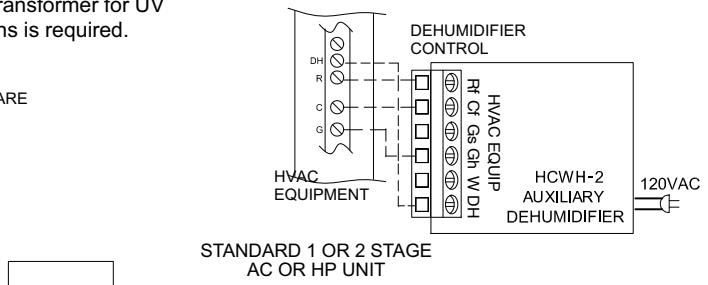
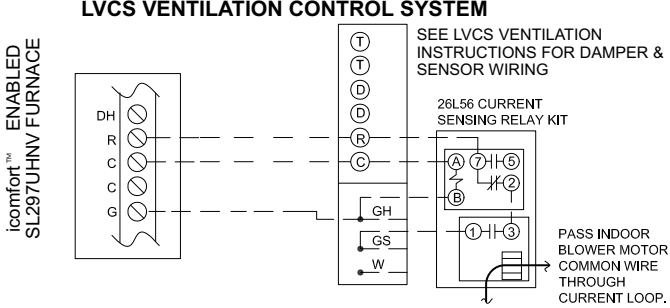
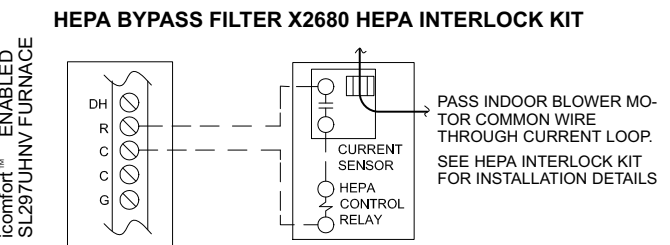
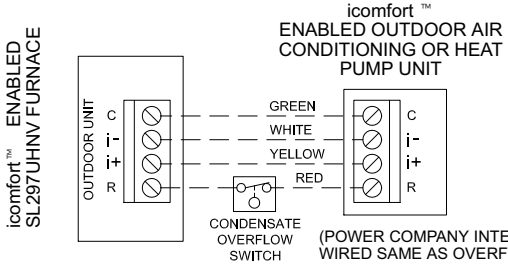

VIII- SL297UHV Field Wiring Applications With Conventional Thermostat

TABLE 30

Thermostat	DIP Switch Settings and On-Board Links (See figure 4)		Wiring Connections																														
	DIP Switch 1 Thermostat Heating Stages	On Board Links Must Be Cut To Select System Options																															
1 Heat / 1 Cool <i>NOTE - Use DIP switch 2 to set second-stage heat ON delay. OFF-7 minutes. ON-12 minutes.</i>	ON	DO NOT CUT ANY ON-BOARD LINKS 	<table border="0"> <thead> <tr> <th>S1 T'STAT</th> <th>FURNACE TERM. STRIP</th> <th>OUTDOOR UNIT</th> </tr> </thead> <tbody> <tr> <td>(W2)</td> <td>(D8)</td> <td></td> </tr> <tr> <td>(W1)-----</td> <td>(W2)</td> <td></td> </tr> <tr> <td>(R)-----</td> <td>(W1)</td> <td></td> </tr> <tr> <td>(G)-----</td> <td>(R)-----*</td> <td>(R)</td> </tr> <tr> <td>(C)-----</td> <td>(G)</td> <td></td> </tr> <tr> <td></td> <td>(C)-----</td> <td>(C)</td> </tr> <tr> <td></td> <td>(Y2)</td> <td></td> </tr> <tr> <td>(Y)-----</td> <td>(Y1)</td> <td>(Y1)</td> </tr> <tr> <td></td> <td>(O)</td> <td></td> </tr> </tbody> </table> <p><i>*Not required on all units</i></p>	S1 T'STAT	FURNACE TERM. STRIP	OUTDOOR UNIT	(W2)	(D8)		(W1)-----	(W2)		(R)-----	(W1)		(G)-----	(R)-----*	(R)	(C)-----	(G)			(C)-----	(C)		(Y2)		(Y)-----	(Y1)	(Y1)		(O)	
S1 T'STAT	FURNACE TERM. STRIP	OUTDOOR UNIT																															
(W2)	(D8)																																
(W1)-----	(W2)																																
(R)-----	(W1)																																
(G)-----	(R)-----*	(R)																															
(C)-----	(G)																																
	(C)-----	(C)																															
	(Y2)																																
(Y)-----	(Y1)	(Y1)																															
	(O)																																
1 Heat / 2 Cool <i>NOTE - Use DIP switch 2 to set second-stage heat ON delay. OFF-7 minutes. ON-12 minutes.</i>	ON	CUT ON-BOARD LINK W915 2 STAGE COMPR 	<table border="0"> <thead> <tr> <th>S1 T'STAT</th> <th>FURNACE TERM. STRIP</th> <th>OUTDOOR UNIT</th> </tr> </thead> <tbody> <tr> <td>(W)</td> <td>(D8)</td> <td></td> </tr> <tr> <td>(W)-----</td> <td>(W2)</td> <td></td> </tr> <tr> <td>(R)-----</td> <td>(W1)</td> <td></td> </tr> <tr> <td>(G)-----</td> <td>(R)-----*</td> <td>(R)</td> </tr> <tr> <td>(C)-----</td> <td>(G)</td> <td></td> </tr> <tr> <td></td> <td>(C)-----</td> <td>(C)</td> </tr> <tr> <td>(Y2)-----</td> <td>(Y2)</td> <td>(Y2)</td> </tr> <tr> <td>(Y1)-----</td> <td>(Y1)</td> <td>(Y1)</td> </tr> <tr> <td></td> <td>(O)</td> <td></td> </tr> </tbody> </table> <p><i>*Not required on all units</i></p>	S1 T'STAT	FURNACE TERM. STRIP	OUTDOOR UNIT	(W)	(D8)		(W)-----	(W2)		(R)-----	(W1)		(G)-----	(R)-----*	(R)	(C)-----	(G)			(C)-----	(C)	(Y2)-----	(Y2)	(Y2)	(Y1)-----	(Y1)	(Y1)		(O)	
S1 T'STAT	FURNACE TERM. STRIP	OUTDOOR UNIT																															
(W)	(D8)																																
(W)-----	(W2)																																
(R)-----	(W1)																																
(G)-----	(R)-----*	(R)																															
(C)-----	(G)																																
	(C)-----	(C)																															
(Y2)-----	(Y2)	(Y2)																															
(Y1)-----	(Y1)	(Y1)																															
	(O)																																
1 Heat / 2 Cool with t'stat with humidity control <i>NOTE - Use DIP switch 2 to set second-stage heat ON delay. OFF-7 minutes. ON-12 minutes.</i>	ON	CUT ON-BOARD LINK W915 2 STAGE COMPR CUT ON-BOARD LINK W914 DEHUM OR HARMONY 	<table border="0"> <thead> <tr> <th>S1 T'STAT</th> <th>FURNACE TERM. STRIP</th> <th>OUTDOOR UNIT</th> </tr> </thead> <tbody> <tr> <td>(D8)-----</td> <td>(D8)</td> <td></td> </tr> <tr> <td></td> <td>(W2)</td> <td></td> </tr> <tr> <td>(W1)-----</td> <td>(W1)</td> <td></td> </tr> <tr> <td>(R)-----</td> <td>(R)-----*</td> <td>(R)</td> </tr> <tr> <td>(G)-----</td> <td>(G)</td> <td></td> </tr> <tr> <td>(C)-----</td> <td>(C)-----</td> <td>(C)</td> </tr> <tr> <td>(Y2)-----</td> <td>(Y2)</td> <td>(Y2)</td> </tr> <tr> <td>(Y1)-----</td> <td>(Y1)</td> <td>(Y1)</td> </tr> <tr> <td></td> <td>(O)</td> <td></td> </tr> </tbody> </table> <p><i>*Not required on all units</i></p>	S1 T'STAT	FURNACE TERM. STRIP	OUTDOOR UNIT	(D8)-----	(D8)			(W2)		(W1)-----	(W1)		(R)-----	(R)-----*	(R)	(G)-----	(G)		(C)-----	(C)-----	(C)	(Y2)-----	(Y2)	(Y2)	(Y1)-----	(Y1)	(Y1)		(O)	
S1 T'STAT	FURNACE TERM. STRIP	OUTDOOR UNIT																															
(D8)-----	(D8)																																
	(W2)																																
(W1)-----	(W1)																																
(R)-----	(R)-----*	(R)																															
(G)-----	(G)																																
(C)-----	(C)-----	(C)																															
(Y2)-----	(Y2)	(Y2)																															
(Y1)-----	(Y1)	(Y1)																															
	(O)																																

TABLE 30
SL297 Field Wiring Applications With Conventional Thermostat (Continued)

Thermostat	DIP Switch Settings and On-Board Links (See figure 4)		Wiring Connections																											
	DIP Switch 1 Thermostat Heating Stages	On Board Links Must Be Cut To Select System Options																												
2 Heat / 2 Cool	OFF	<p>CUT ON-BOARD LINK W915 2 STAGE COMPR</p> 	<table border="0"> <thead> <tr> <th>S1 T'STAT</th> <th>FURNACE TERM. STRIP</th> <th>OUTDOOR UNIT</th> </tr> </thead> <tbody> <tr> <td></td> <td align="center">D8</td> <td></td> </tr> <tr> <td>W2</td> <td>W2</td> <td></td> </tr> <tr> <td>W1</td> <td>W1</td> <td></td> </tr> <tr> <td>R</td> <td>R</td> <td>* R</td> </tr> <tr> <td>G</td> <td>G</td> <td></td> </tr> <tr> <td>C</td> <td>C</td> <td>C</td> </tr> <tr> <td>Y2</td> <td>Y2</td> <td>Y2</td> </tr> <tr> <td>Y1</td> <td>Y1</td> <td>Y1</td> </tr> </tbody> </table> <p><i>*Not required on all units</i> O</p>	S1 T'STAT	FURNACE TERM. STRIP	OUTDOOR UNIT		D8		W2	W2		W1	W1		R	R	* R	G	G		C	C	C	Y2	Y2	Y2	Y1	Y1	Y1
S1 T'STAT	FURNACE TERM. STRIP	OUTDOOR UNIT																												
	D8																													
W2	W2																													
W1	W1																													
R	R	* R																												
G	G																													
C	C	C																												
Y2	Y2	Y2																												
Y1	Y1	Y1																												
2 Heat / 2 Cool with t'stat with humidity control	OFF	<p>CUT ON-BOARD LINK W915 2 STAGE COMPR</p> <p>CUT ON-BOARD LINK W914 DEHUM OR HARMONY</p> 	<table border="0"> <thead> <tr> <th>S1 T'STAT</th> <th>FURNACE TERM. STRIP</th> <th>OUTDOOR UNIT</th> </tr> </thead> <tbody> <tr> <td></td> <td align="center">D8</td> <td></td> </tr> <tr> <td>W2</td> <td>W2</td> <td></td> </tr> <tr> <td>W1</td> <td>W1</td> <td></td> </tr> <tr> <td>R</td> <td>R</td> <td>* R</td> </tr> <tr> <td>G</td> <td>G</td> <td></td> </tr> <tr> <td>C</td> <td>C</td> <td>C</td> </tr> <tr> <td>Y2</td> <td>Y2</td> <td>Y2</td> </tr> <tr> <td>Y1</td> <td>Y1</td> <td>Y1</td> </tr> </tbody> </table> <p><i>*Not required on all units</i> O</p>	S1 T'STAT	FURNACE TERM. STRIP	OUTDOOR UNIT		D8		W2	W2		W1	W1		R	R	* R	G	G		C	C	C	Y2	Y2	Y2	Y1	Y1	Y1
S1 T'STAT	FURNACE TERM. STRIP	OUTDOOR UNIT																												
	D8																													
W2	W2																													
W1	W1																													
R	R	* R																												
G	G																													
C	C	C																												
Y2	Y2	Y2																												
Y1	Y1	Y1																												
2 Heat / 1 Cool with t'stat with humidity control	OFF	<p>CUT ON-BOARD LINK W914 DEHUM OR HARMONY</p> 	<table border="0"> <thead> <tr> <th>S1 T'STAT</th> <th>FURNACE TERM. STRIP</th> <th>OUTDOOR UNIT</th> </tr> </thead> <tbody> <tr> <td></td> <td align="center">D8</td> <td></td> </tr> <tr> <td>W2</td> <td>W2</td> <td></td> </tr> <tr> <td>W1</td> <td>W1</td> <td></td> </tr> <tr> <td>R</td> <td>R</td> <td>* R</td> </tr> <tr> <td>G</td> <td>G</td> <td></td> </tr> <tr> <td>C</td> <td>C</td> <td>C</td> </tr> <tr> <td>Y1</td> <td>Y1</td> <td>Y1</td> </tr> <tr> <td></td> <td align="center">O</td> <td></td> </tr> </tbody> </table> <p><i>*Not required on all units</i></p>	S1 T'STAT	FURNACE TERM. STRIP	OUTDOOR UNIT		D8		W2	W2		W1	W1		R	R	* R	G	G		C	C	C	Y1	Y1	Y1		O	
S1 T'STAT	FURNACE TERM. STRIP	OUTDOOR UNIT																												
	D8																													
W2	W2																													
W1	W1																													
R	R	* R																												
G	G																													
C	C	C																												
Y1	Y1	Y1																												
	O																													
2 Heat / 1 Cool	OFF	<p>DO NOT CUT ANY ON-BOARD LINKS</p> 	<table border="0"> <thead> <tr> <th>S1 T'STAT</th> <th>FURNACE TERM. STRIP</th> <th>OUTDOOR UNIT</th> </tr> </thead> <tbody> <tr> <td></td> <td align="center">D8</td> <td></td> </tr> <tr> <td>W2</td> <td>W2</td> <td></td> </tr> <tr> <td>W1</td> <td>W1</td> <td></td> </tr> <tr> <td>R</td> <td>R</td> <td>* R</td> </tr> <tr> <td>G</td> <td>G</td> <td></td> </tr> <tr> <td>C</td> <td>C</td> <td>C</td> </tr> <tr> <td></td> <td align="center">Y2</td> <td></td> </tr> <tr> <td>Y</td> <td>Y1</td> <td>Y1</td> </tr> </tbody> </table> <p><i>*Not required on all units</i> O</p>	S1 T'STAT	FURNACE TERM. STRIP	OUTDOOR UNIT		D8		W2	W2		W1	W1		R	R	* R	G	G		C	C	C		Y2		Y	Y1	Y1
S1 T'STAT	FURNACE TERM. STRIP	OUTDOOR UNIT																												
	D8																													
W2	W2																													
W1	W1																													
R	R	* R																												
G	G																													
C	C	C																												
	Y2																													
Y	Y1	Y1																												

TABLE 30
SL297 Field Wiring Applications With Conventional Thermostat (Continued)

Thermostat	DIP Switch Settings and On-Board Links (figure 4)		Wiring Connections																																													
	DIP Switch 1 Thermostat Heating Stages	On Board Links Must Be Cut To Select System Options																																														
Dual Fuel Single Stage Heat Pump ComfortSense 7000 L7724U thermostat w/ dual fuel capabilities Capable of 2 stage gas heat control	OFF	<p>CUT ON-BOARD LINK W951 HEAT PUMP</p>	<table border="0"> <tr> <td>L7724U T'STAT</td> <td>FURNACE TERM. STRIP</td> <td>HEAT PUMP</td> </tr> <tr> <td>R</td> <td>R</td> <td>R</td> </tr> <tr> <td>H</td> <td></td> <td></td> </tr> <tr> <td>W2</td> <td>W2</td> <td>67M41*</td> </tr> <tr> <td>W1</td> <td>W1</td> <td>W1</td> </tr> <tr> <td>O</td> <td>O</td> <td>O</td> </tr> <tr> <td>L</td> <td></td> <td>L</td> </tr> <tr> <td>Y1</td> <td>Y1</td> <td>Y</td> </tr> <tr> <td>Y2</td> <td></td> <td></td> </tr> <tr> <td>G</td> <td>G</td> <td></td> </tr> <tr> <td>D</td> <td>DS</td> <td></td> </tr> <tr> <td>B</td> <td>Y2</td> <td></td> </tr> <tr> <td>C</td> <td>C</td> <td>C</td> </tr> <tr> <td>T</td> <td></td> <td>outdoor sensor</td> </tr> <tr> <td>T</td> <td></td> <td></td> </tr> </table>	L7724U T'STAT	FURNACE TERM. STRIP	HEAT PUMP	R	R	R	H			W2	W2	67M41*	W1	W1	W1	O	O	O	L		L	Y1	Y1	Y	Y2			G	G		D	DS		B	Y2		C	C	C	T		outdoor sensor	T		
L7724U T'STAT	FURNACE TERM. STRIP	HEAT PUMP																																														
R	R	R																																														
H																																																
W2	W2	67M41*																																														
W1	W1	W1																																														
O	O	O																																														
L		L																																														
Y1	Y1	Y																																														
Y2																																																
G	G																																															
D	DS																																															
B	Y2																																															
C	C	C																																														
T		outdoor sensor																																														
T																																																
Dual Fuel Two Stage Heat Pump ComfortSense 7000 L7724U thermostat w/ dual fuel capabilities Capable of 2 stage gas heat control	OFF	<p>CUT ON-BOARD LINK W915 2 STAGE COMPR</p> <p>CUT ON-BOARD LINK W951 HEAT PUMP</p>	<table border="0"> <tr> <td>L7724U T'STAT</td> <td>FURNACE TERM. STRIP</td> <td>HEAT PUMP</td> </tr> <tr> <td>R</td> <td>R</td> <td>R</td> </tr> <tr> <td>H</td> <td></td> <td></td> </tr> <tr> <td>W2</td> <td>W2</td> <td>67M41*</td> </tr> <tr> <td>W1</td> <td>W1</td> <td>W1</td> </tr> <tr> <td>O</td> <td>O</td> <td>O</td> </tr> <tr> <td>L</td> <td></td> <td>L</td> </tr> <tr> <td>Y1</td> <td>Y1</td> <td>Y1</td> </tr> <tr> <td>Y2</td> <td></td> <td>Y2</td> </tr> <tr> <td>G</td> <td>G</td> <td></td> </tr> <tr> <td>D</td> <td>DS</td> <td></td> </tr> <tr> <td>B</td> <td>Y2</td> <td>Y2 out blue</td> </tr> <tr> <td>C</td> <td>C</td> <td>C</td> </tr> <tr> <td>T</td> <td></td> <td>outdoor sensor</td> </tr> <tr> <td>T</td> <td></td> <td></td> </tr> </table>	L7724U T'STAT	FURNACE TERM. STRIP	HEAT PUMP	R	R	R	H			W2	W2	67M41*	W1	W1	W1	O	O	O	L		L	Y1	Y1	Y1	Y2		Y2	G	G		D	DS		B	Y2	Y2 out blue	C	C	C	T		outdoor sensor	T		
L7724U T'STAT	FURNACE TERM. STRIP	HEAT PUMP																																														
R	R	R																																														
H																																																
W2	W2	67M41*																																														
W1	W1	W1																																														
O	O	O																																														
L		L																																														
Y1	Y1	Y1																																														
Y2		Y2																																														
G	G																																															
D	DS																																															
B	Y2	Y2 out blue																																														
C	C	C																																														
T		outdoor sensor																																														
T																																																

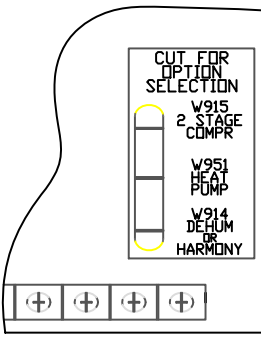
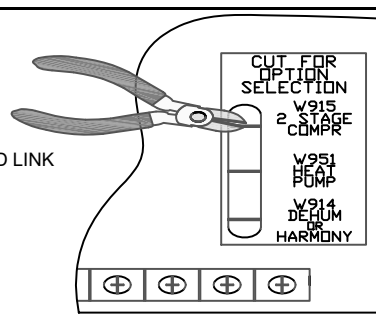
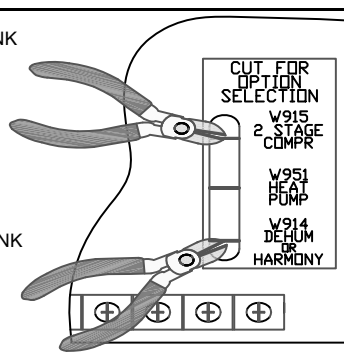
* Connect W1 to W1 ONLY if using defrost tempering kit 67M41

NOTE - **Do NOT** make a wire connection between the room thermostat L terminal and the L terminal of the SL297 integrated control.

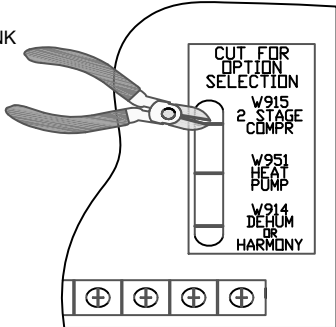
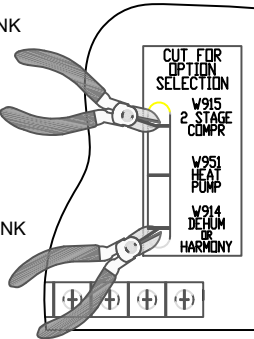
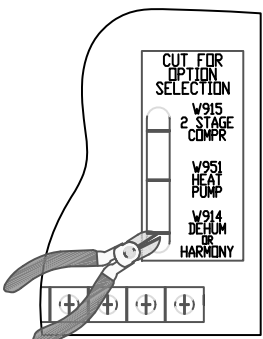
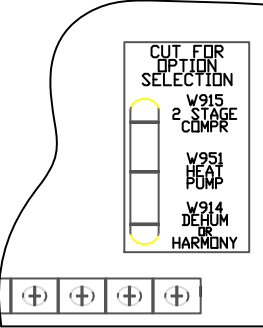
TABLE 30
SL297 Field Wiring Applications With Conventional Thermostat (Continued)

Thermostat	DIP Switch Settings and On-Board Links (figure 4)		Wiring Connections																																													
	DIP Switch 1 Thermostat Heating Stages	On Board Links Must Be Cut To Select System Options																																														
Dual Fuel Single Stage Heat Pump ComfortSense 7000 L7724U thermostat w/ dual fuel capa- bilities Capable of 2 stage gas heat control w/dehu- midification control	OFF	<p>CUT ON-BOARD LINK W915 2 STAGE COMPR</p> <p>CUT ON-BOARD LINK W951 HEAT PUMP</p> <p>CUT ON-BOARD LINK W914 DEHUM OR HARMONY</p>	<table border="0"> <tr> <td>L7724U T'STAT</td> <td>FURNACE TERM. STRIP</td> <td>HEAT PUMP</td> </tr> <tr> <td>(R)-----</td> <td>(R)-----</td> <td>(R)</td> </tr> <tr> <td>(H)-----</td> <td></td> <td></td> </tr> <tr> <td>(W2)-----</td> <td>(W2)-----</td> <td>67M41*</td> </tr> <tr> <td>(W1)-----</td> <td>(W1) ←</td> <td>↔ (W1)</td> </tr> <tr> <td>(O)-----</td> <td>(O)-----</td> <td>(O)</td> </tr> <tr> <td>(L)-----</td> <td></td> <td>(L)</td> </tr> <tr> <td>(Y1)-----</td> <td>(Y1)-----</td> <td>(Y)</td> </tr> <tr> <td>(Y2)-----</td> <td></td> <td></td> </tr> <tr> <td>(G)-----</td> <td>(G)-----</td> <td></td> </tr> <tr> <td>(D)-----</td> <td>(DS)-----</td> <td></td> </tr> <tr> <td>(B)-----</td> <td>(Y2)-----</td> <td></td> </tr> <tr> <td>(C)-----</td> <td>(C)-----</td> <td>(C)</td> </tr> <tr> <td>(T)-----</td> <td></td> <td>outdoor sensor</td> </tr> <tr> <td>(T)-----</td> <td></td> <td></td> </tr> </table>	L7724U T'STAT	FURNACE TERM. STRIP	HEAT PUMP	(R)-----	(R)-----	(R)	(H)-----			(W2)-----	(W2)-----	67M41*	(W1)-----	(W1) ←	↔ (W1)	(O)-----	(O)-----	(O)	(L)-----		(L)	(Y1)-----	(Y1)-----	(Y)	(Y2)-----			(G)-----	(G)-----		(D)-----	(DS)-----		(B)-----	(Y2)-----		(C)-----	(C)-----	(C)	(T)-----		outdoor sensor	(T)-----		
L7724U T'STAT	FURNACE TERM. STRIP	HEAT PUMP																																														
(R)-----	(R)-----	(R)																																														
(H)-----																																																
(W2)-----	(W2)-----	67M41*																																														
(W1)-----	(W1) ←	↔ (W1)																																														
(O)-----	(O)-----	(O)																																														
(L)-----		(L)																																														
(Y1)-----	(Y1)-----	(Y)																																														
(Y2)-----																																																
(G)-----	(G)-----																																															
(D)-----	(DS)-----																																															
(B)-----	(Y2)-----																																															
(C)-----	(C)-----	(C)																																														
(T)-----		outdoor sensor																																														
(T)-----																																																
Dual Fuel Two Stage Heat Pump ComfortSense 7000 L7724U thermostat w/ dual fuel capa- bilities Capable of 2 stage gas heat control w/dehu- midification	OFF	<p>CUT ON-BOARD LINK W915 2 STAGE COMPR</p> <p>CUT ON-BOARD LINK W951 HEAT PUMP</p> <p>CUT ON-BOARD LINK W914 DEHUM OR HARMONY</p>	<table border="0"> <tr> <td>L7724U T'STAT</td> <td>FURNACE TERM. STRIP</td> <td>HEAT PUMP</td> </tr> <tr> <td>(R)-----</td> <td>(R)-----</td> <td>(R)</td> </tr> <tr> <td>(H)-----</td> <td></td> <td></td> </tr> <tr> <td>(W2)-----</td> <td>(W2)-----</td> <td>67M41*</td> </tr> <tr> <td>(W1)-----</td> <td>(W1) ←</td> <td>↔ (W1)</td> </tr> <tr> <td>(O)-----</td> <td>(O)-----</td> <td>(O)</td> </tr> <tr> <td>(L)-----</td> <td></td> <td>(L)</td> </tr> <tr> <td>(Y1)-----</td> <td>(Y1)-----</td> <td>(Y1)</td> </tr> <tr> <td>(Y2)-----</td> <td></td> <td>(Y2)</td> </tr> <tr> <td>(G)-----</td> <td>(G)-----</td> <td></td> </tr> <tr> <td>(D)-----</td> <td>(DS)-----</td> <td></td> </tr> <tr> <td>(B)-----</td> <td>(Y2)-----</td> <td>Y2 out blue</td> </tr> <tr> <td>(C)-----</td> <td>(C)-----</td> <td>(C)</td> </tr> <tr> <td>(T)-----</td> <td></td> <td>outdoor sensor</td> </tr> <tr> <td>(T)-----</td> <td></td> <td></td> </tr> </table>	L7724U T'STAT	FURNACE TERM. STRIP	HEAT PUMP	(R)-----	(R)-----	(R)	(H)-----			(W2)-----	(W2)-----	67M41*	(W1)-----	(W1) ←	↔ (W1)	(O)-----	(O)-----	(O)	(L)-----		(L)	(Y1)-----	(Y1)-----	(Y1)	(Y2)-----		(Y2)	(G)-----	(G)-----		(D)-----	(DS)-----		(B)-----	(Y2)-----	Y2 out blue	(C)-----	(C)-----	(C)	(T)-----		outdoor sensor	(T)-----		
L7724U T'STAT	FURNACE TERM. STRIP	HEAT PUMP																																														
(R)-----	(R)-----	(R)																																														
(H)-----																																																
(W2)-----	(W2)-----	67M41*																																														
(W1)-----	(W1) ←	↔ (W1)																																														
(O)-----	(O)-----	(O)																																														
(L)-----		(L)																																														
(Y1)-----	(Y1)-----	(Y1)																																														
(Y2)-----		(Y2)																																														
(G)-----	(G)-----																																															
(D)-----	(DS)-----																																															
(B)-----	(Y2)-----	Y2 out blue																																														
(C)-----	(C)-----	(C)																																														
(T)-----		outdoor sensor																																														
(T)-----																																																

* Connect W1 to W1 ONLY if using defrost tempering kit 67M41

NOTE - **Do NOT** make a wire connection between the room thermostat L terminal and the L terminal of the SL297 integrated control.

IX- Program Unit Capacity Size Modes

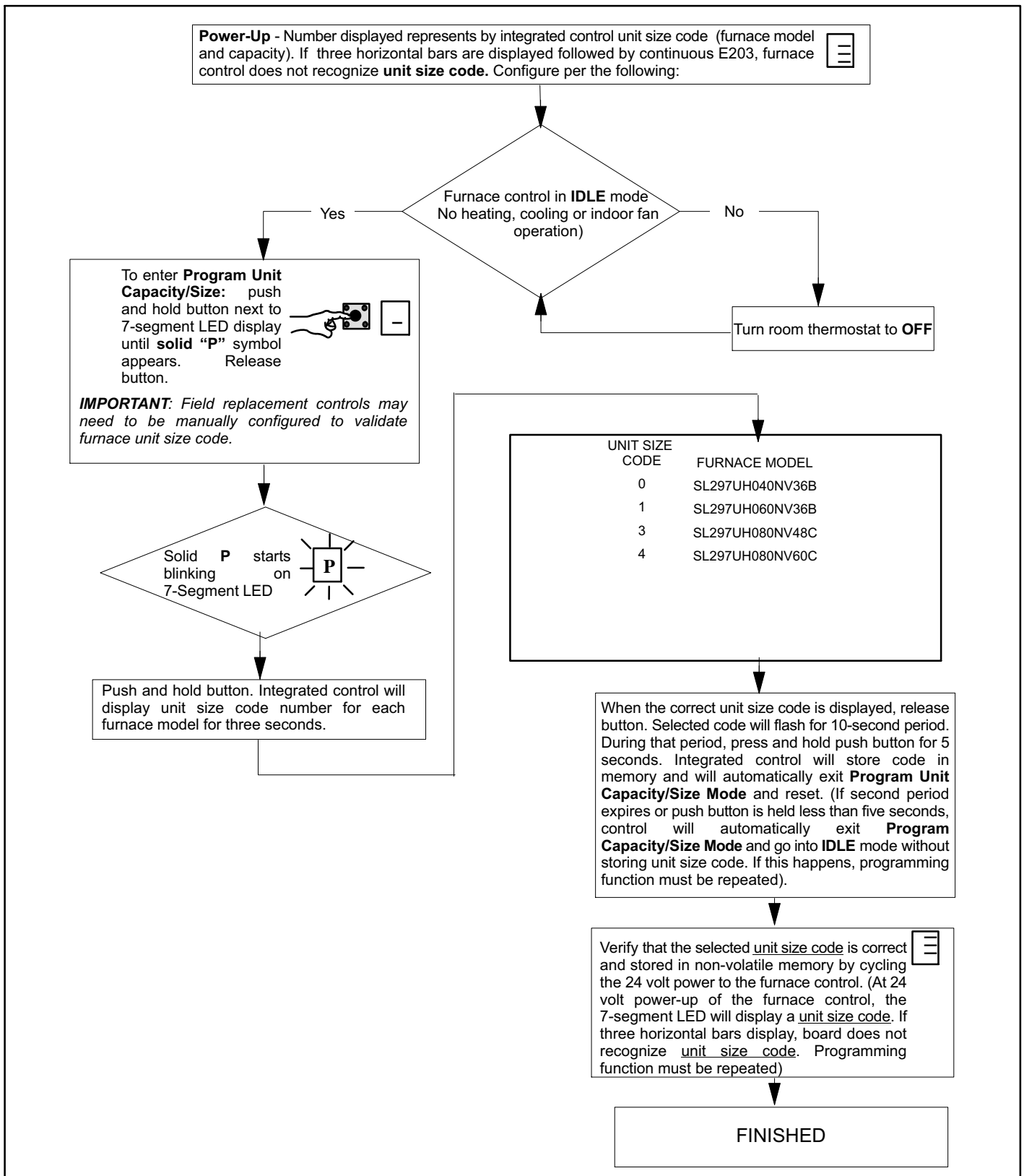

X- Troubleshooting

Troubleshooting: Heating Sequence of Operation

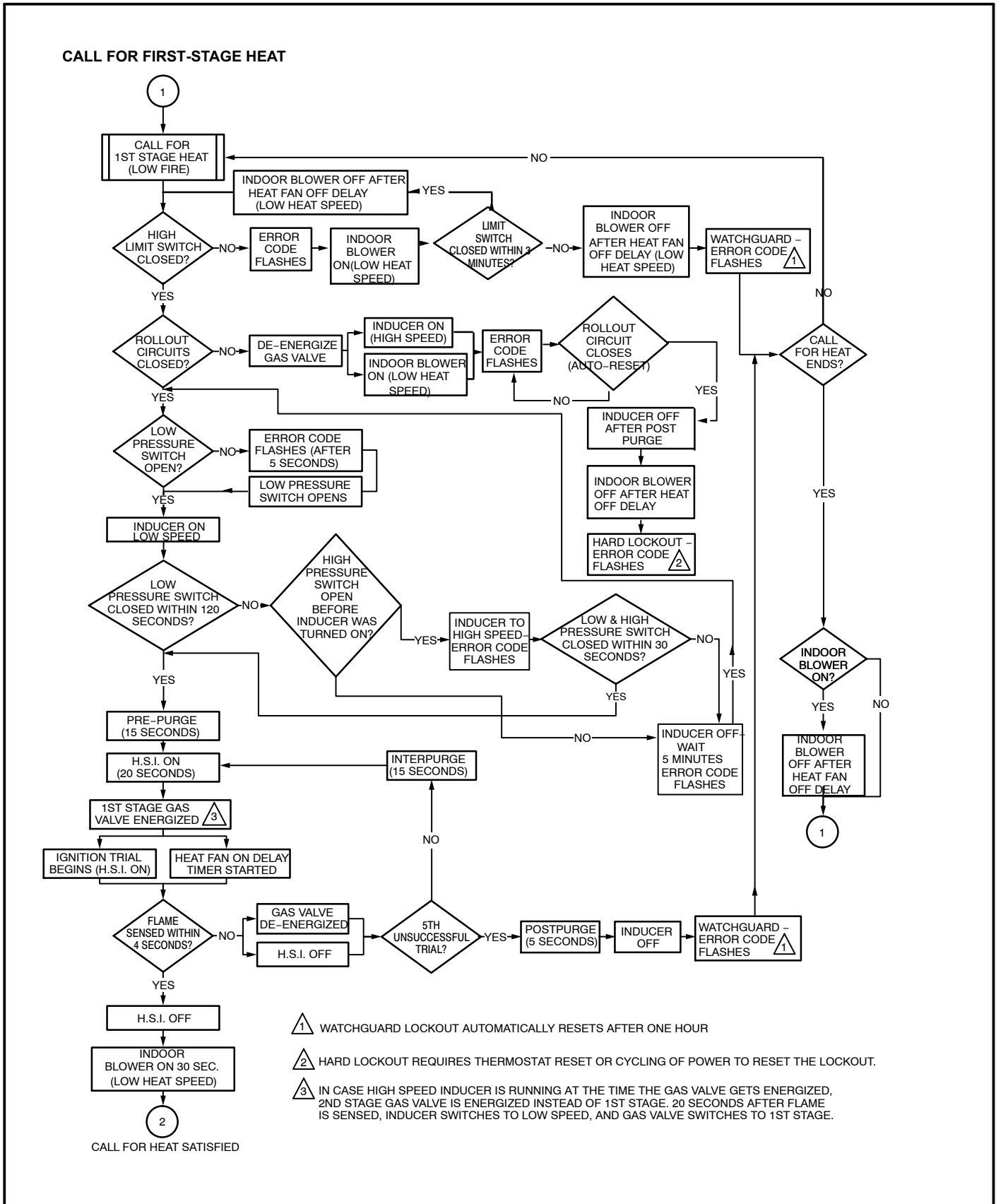

Troubleshooting: Heating Sequence of Operation (Continued)

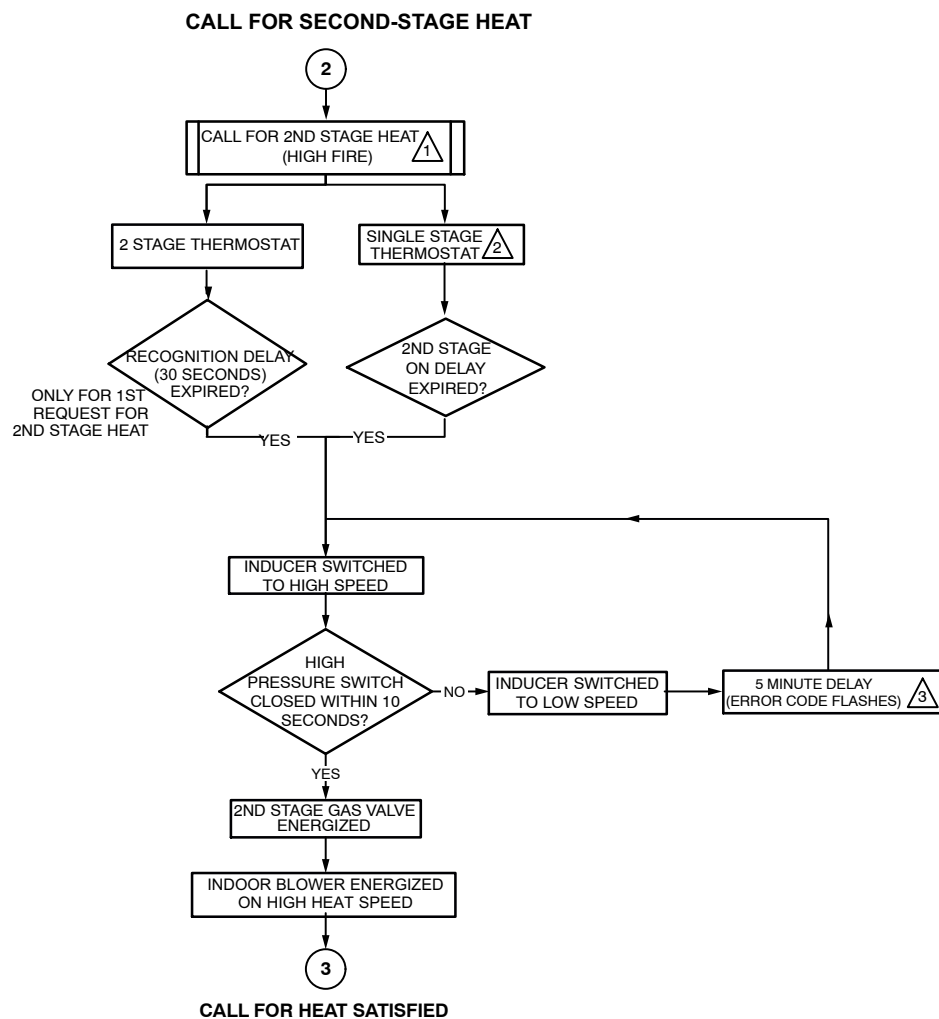

1 SYSTEM WILL ALWAYS LIGHT ON LOW FIIRE, EVEN IF 2ND STAGE HEAT IS IN PLACE.

2 WHEN USED WITH A SINGLE STAGE THERMOSTAT, SET SW1 TO THE ON POSITION IN DIP SWITCH S4.

3 IF THE HIGH FIRE PRESSURE SWITCH DOES NOT CLOSE WITHIN 5 ATTEMPTS, THE SYSTEM WILL OPERATE AT LOW FIRE FOR THE REMAINDER OF THE CALL FOR HEAT REQUEST.

Troubleshooting: Heating Sequence of Operation (Continued)

CALL FOR HEAT SATISFIED

FIRST-STAGE HEAT SECOND-STAGE HEAT

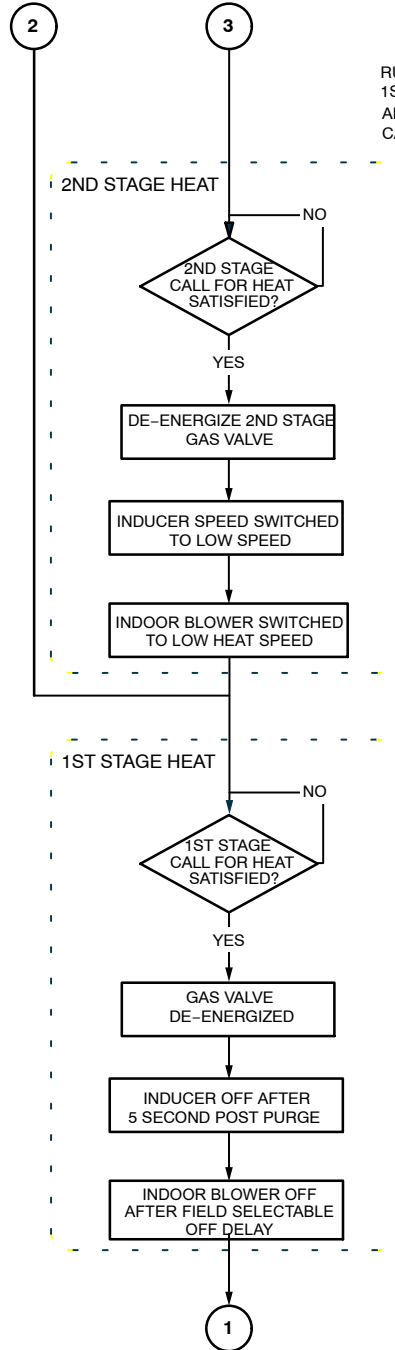

RUN MODE:
1ST OR 2ND STAGE CALL FOR HEAT.
ALL INPUTS MONITORED (LIMIT, PRESSURE,
CALL FOR HEAT/COOL, FLAME LEVEL)

Troubleshooting: Cooling Sequence of Operation (Continued)

