



PRODUCT LITERATURE

Lennox Industries Inc.
Dallas, Texas

PARTS AND OPTIONAL ACCESSORIES

GWB8-050E-3, GWB8-075E-3,
GWB8-100E-3, GWB8-125E-3
GWB8-150E-3, 2GWB8-170E-3
GWB8-200E-3

GAS FIRED BOILER

**RETAIN THESE INSTRUCTIONS FOR
FUTURE REFERENCE**

***These instructions must be affixed on
or adjacent to the boiler.***

REPLACEMENT PARTS - BASE

BOILER BASE

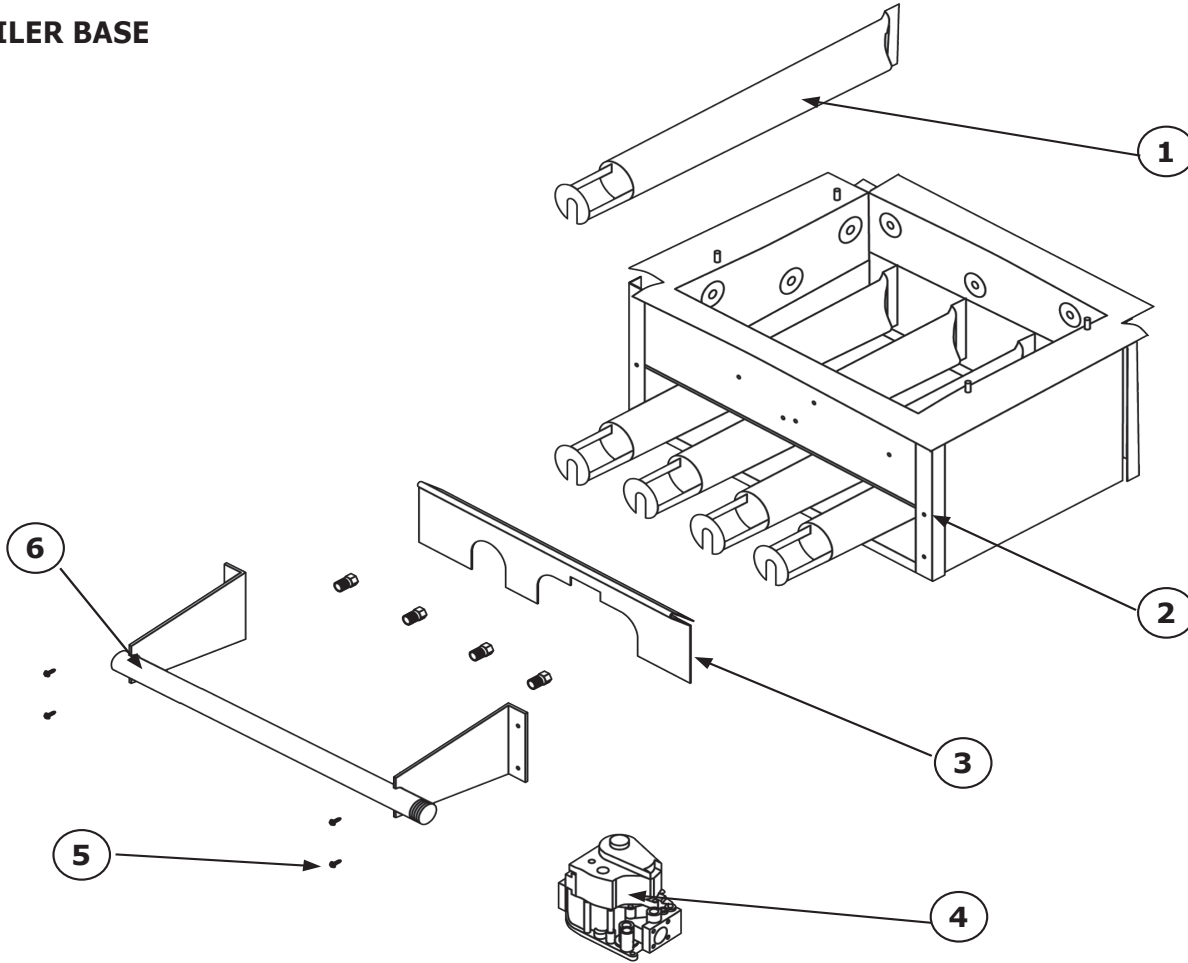

Item #	Description	Part #	Qty.	Item #	Description	Part #	Qty.
1	BURNER TUBE 1 1/2" - 50	240005543	1	5	SCREW ¼ - 20 X ½ SELF TAP	HW-005.01	4
	BURNER TUBE 1 1/2" - 75, 100		2	6	MANIFOLD - 50	356-2-1.01	1
	BURNER TUBE 1 1/2" - 125, 150		3		MANIFOLD - 75 & 100	356-2-1.02	
	BURNER TUBE 1 1/2" - 170, 200		4		MANIFOLD - 125 & 150	356-2-1.03	
		MANIFOLD - 170 & 200	356-2-1.04				
2	BASE W/INSUL - 50	5611601	1	7	ORIFICE 3.2mm NAT - 50, 100, 150, 200,	240007406	*
	BASE W/INSUL - 75, 100	5611602			ORIFICE 2.9mm NAT - 125, 170	240007403	
	BASE W/INSUL - 125, 150	3001823			ORIFICE 2.8mm NAT - 75	240007402	
	BASE W/INSUL - 170, 200	5611604			ORIFICE #45 LP - 50	3551520	
3	BURNER DOOR - 50	109009071	1		ORIFICE #47 LP - 100, 150, 200	355-1-5.04	
	BURNER DOOR - 75, 100	109009072			ORIFICE #49 LP - 125 & 170	355-1-5.06	
	BURNER DOOR - 125, 150	109009073			ORIFICE #50 LP - 75	355-1-5.07	
	BURNER DOOR - 170, 200	109009074					
4	GAS VALVE VR8204H - 50 - 150 SPARK NAT	VG01101	1	NOT SHOWN	COMBUSTIBLE BASE FLOORING - 50	325-2-8.01	1
	GAS VALVE VR8304H4 - 170-200 SPARK NAT	VG01103			COMBUSTIBLE BASE FLOORING - 75, 100	325-2-8.02	
	GAS VALVE VR8304 - 50-200 SPARK LP	VG01104			COMBUSTIBLE BASE FLOORING - 125, 150	325-2-8.03	
			COMBUSTIBLE BASE FLOORING - 170, 200		325-2-8.04		

* Orifice Quantities: Model 50 - qty 1; Model 75 & 100- qty 2; Model 125 & 150- qty 3; Model 170 & 200 - qty 4

REPLACEMENT PARTS - HEAT EXCHANGER

HEAT EXCHANGER

Fully Assembled Heat Exchangers	
912000001	Heat Exchanger (2 Section)
912000002	Heat Exchanger (3 Section)
912000003	Heat Exchanger (4 Section)
912000004	Heat Exchanger (5 Section)

ROLLOUT & SPILL SWITCH

ROLLOUT & SPILL SWITCH

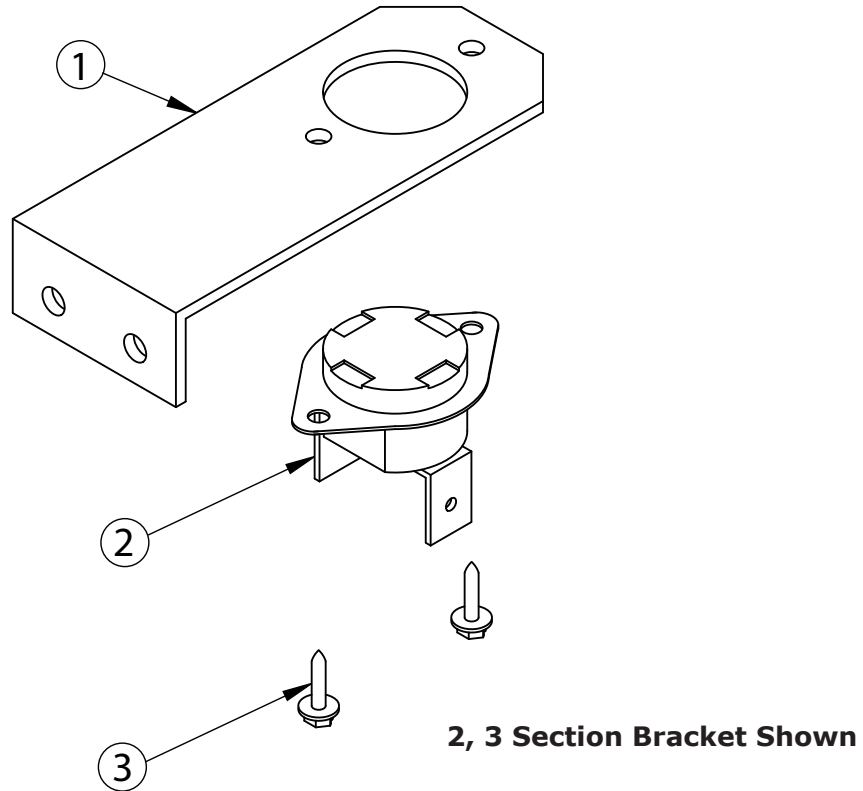

Item #	Description	Part #	Qty.
1	2 SECTION TEMP. SENSOR BRACKET (Rollout)	32611001	1
	3 SECTION TEMP. SENSOR BRACKET (Rollout)	3262001	1
	4 SECTION TEMP. SENSOR BRACKET (Rollout)	109008517	1
	5 SECTION TEMP. SENSOR BRACKET (Rollout)	109008518	1
2	CONTROL-FIXED TEMPERATURE THERMO (Rollout switch and Spill switch)	AQ02101	1
3	SCREW - #6 X 1/4 HEX HD	HW06501	2

Rollout switch is located on base; spill switch on flue collector.

NOTE: Quantities above are for each switch.

REPLACEMENT PARTS - JACKET

BOILER JACKET

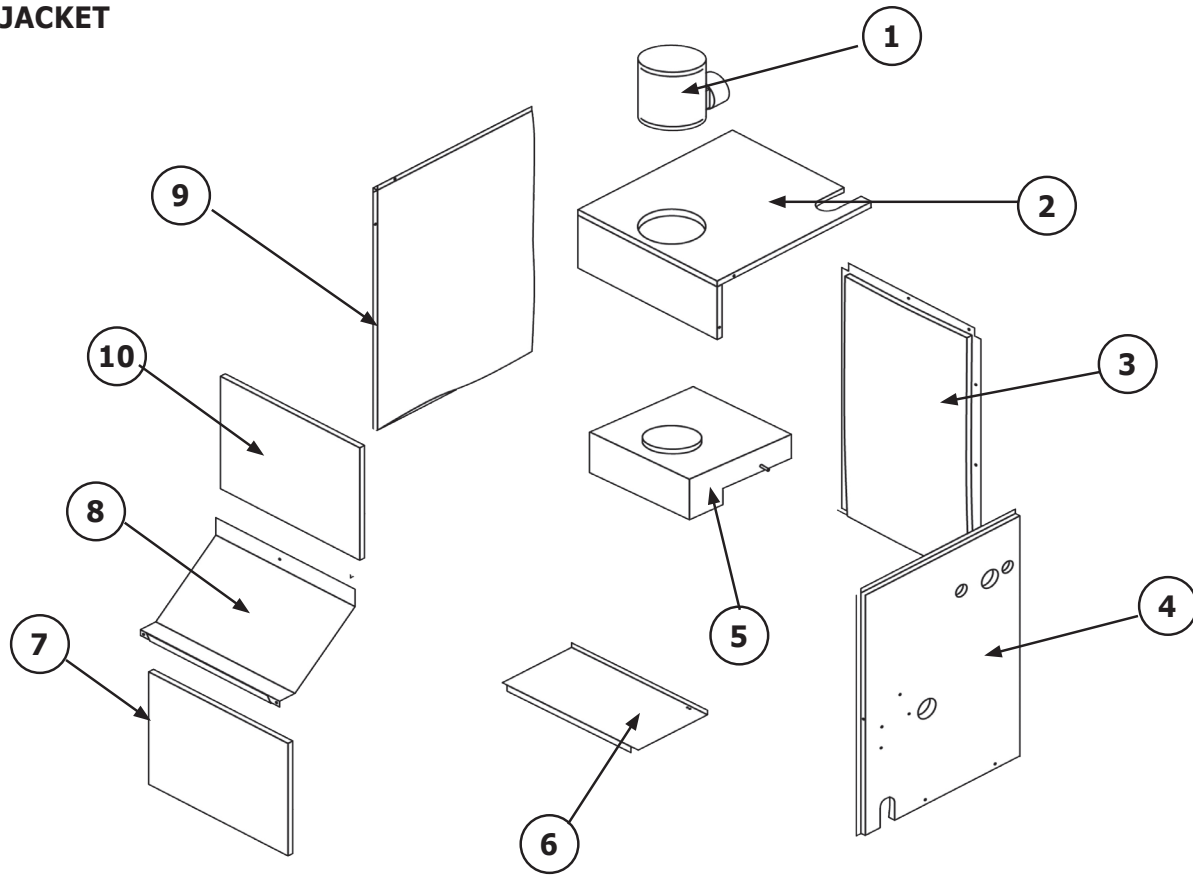

Item #	DESCRIPTION	Part Number	Qty.
1	DAMPER 4" 50	240006936	1
	DAMPER 5" 75	240006937	
	DAMPER 6" 100 & 125	240006938	
	DAMPER 7" 150 & 170	240006939	
	DAMPER 8" 200	240006940	
2	PANEL - TOP 50	31621501AF	1
	PANEL - TOP 75 & 100	31621502AF	
	PANEL - TOP 125	31621503AF	
	PANEL - TOP 150	31621504AF	
	PANEL - TOP 170 & 200	31621505AF	
3	PANEL - REAR 50	3162601AF	1
	PANEL - REAR 75 & 100	3162602AF	
	PANEL - REAR 125 & 150	3162603AF	
	PANEL - REAR 170 & 200	3162604AF	
4	PANEL - RIGHT	109008633AF	1
5	FLUE COL 50	3462101	1
	FLUE COL 75	3462108	
	FLUE COL 100	3462102	
	FLUE COL 125	3462107	
	FLUE COL 150	3462103	
	FLUE COL 170	3462109	
	FLUE COL 200	3462104	

Item #	DESCRIPTION	Part Number	Qty.
6	PANEL - BASE 50	3161201AF	1
	PANEL - BASE 75 & 100	3161202AF	
	PANEL - BASE 125 & 150	3161203AF	
	PANEL - BASE 170 & 200	3161204AF	
7	PNL LWR ACCES 50	3161101AF	1
	PNL LWR ACCES 75/100	3161102AF	
	PNL LWR ACCES 125/150	3161103AF	
	PNL LWR ACCES 170/200	3161104AF	
8	DRAFT DEFLECTOR 50	3162501AF	1
	DRAFT DEFLECTOR 75/100	3162502AF	
	DRAFT DEFLECTOR 125/150	3162503AF	
	DRAFT DEFLECTOR 170/200	3162504AF	
9	PANEL - LEFT	3162708AF	1
10	PNL- UPPER ACCESS 50	31621201AF	1
	PNL- UPPER ACCESS 75&100	31621202AF	
	PNL- UPPER ACCESS 125	31621203AF	
	PNL- UPPER ACCESS 170 & 200	31621205AF	

SPARK PILOT

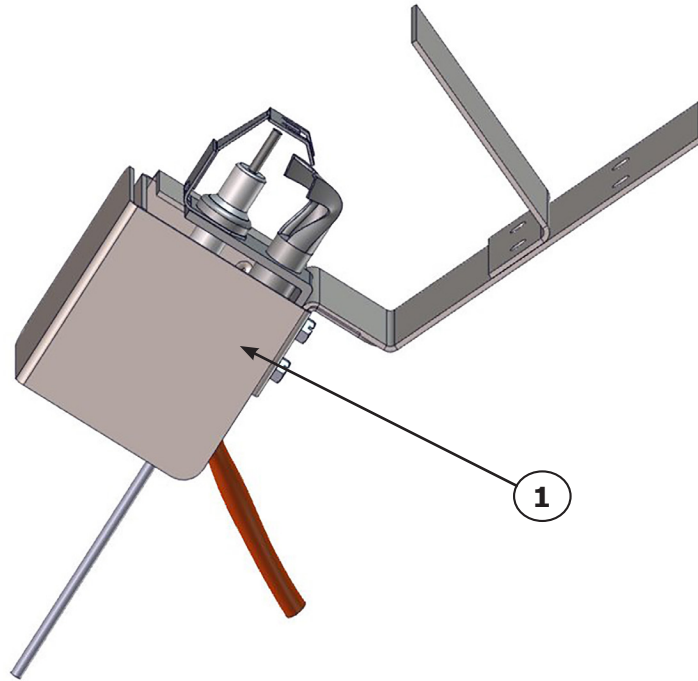

Spark Pilot Kit - Natural Gas 550003039		
Spark Pilot Kit - LP/Propane 550003040		
Item #	Description	Qty.
1	PILOT AND BRACKET ASSEMBLY (NAT. GAS)	1
	PILOT AND BRACKET ASSY (LP/PROPANE)	
*	BRACKET SCREW	2
*	COMPRESSION FITTING	1
* NOT SHOWN		

REPLACEMENT PARTS - PIPING & CONTROLS

PIPING & CONTROLS

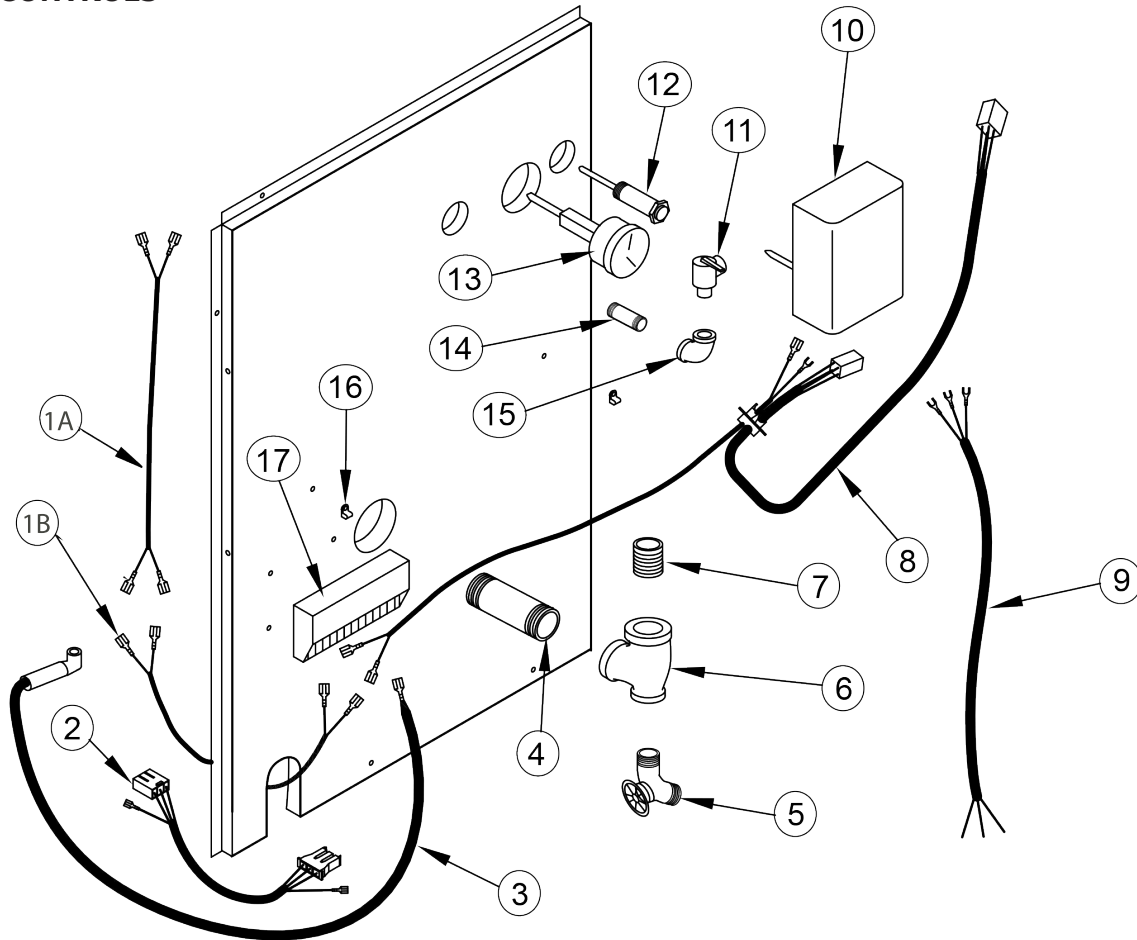

ITEM	DESCRIPTION	P/N	QTY.
1A	WIRE ROLLOUT/SPILL 48"	240010924	1
1B	WIRE ROLLOUT/SPILL	37513301	1
2	HARNESS IGN TO G/V 18"	37413602	1
3	PILOT IGNITION CABLE 36"	240009313	1
	BOOT,CABLE,IGNITION,HW	240011273	1
4	PIPE - NPL 1.1/4X4.1/2 NPT	1310002	1
5	DRAIN - SHORT	240009323	1
6	PIPE - TEE 1.1/4X3/4X1.1/4	1510001	1
7	PIPE - 1.1/4" CLOSE NPL	PF-006.01	1
8	WIRE LOW VOLTAGE/DAMPER	240005480	1
9	HARNESS CIRCULATOR 72"	37519501	1
10	CONTROL HYDROLEVEL 3200	240009113	1
11	RELIEF VALVE 30#	VR-001.01	1
12	WELL HYDROLEVEL	240009115	1
13	GAUGE - TEMPERATURE - PRESSURE	1260006	1
14	PIPE - NPL 3/4"X4"	1310001	1
15	PIPE - ELBOW 3/4" 90°	1190001	1
16	CLAMP #3600 WHITE	EF03601	3
17	PLT SPARK CTRL S8600	14662070	1
	BRACKET, SPARK CONTROL	109008481	1



PRODUCT LITERATURE
Lennox Industries Inc.
Dallas, Texas