

### INSTALLATION INSTRUCTIONS FOR LENNOX MODELS UVO3-500, UVO3-1000, UVO3-2000

#### General

The Lennox<sup>®</sup> Healthy Climate™ germicidal light emits ultraviolet (UVC) energy, which has been proven effective in reducing microbes such as viruses, bacteria, yeasts, and molds. This UVC germicidal lamp also includes an ozone generating feature.

UVC germicidal lights greatly reduce the growth and proliferation of mold and other bioaerosols (bacteria and viruses) on illuminated surfaces.

This UVC germicidal light is NOT intended to be used for remediation of active mold growth.

#### ⚠ WARNING

The UVC germicidal light should not be installed in retrofit applications where mold already exists. Use of a UVC light in these applications may temporarily increase airborne mold compounds (spores and decay products). These compounds can aggravate health conditions. Mold should be removed by a qualified mold remediation specialist before the UVC light is installed.

Mold remediation companies and training can be found by contacting the Indoor Air Quality Association (IAQA) at PH: 301 962-3804; Website: [www.iaqa.org](http://www.iaqa.org)) or by contacting your state's health department.

Once the mold is removed by a qualified mold remediation company, germicidal lights will greatly reduce new mold growth on illuminated surfaces.

#### Shipping and Packing List

##### Package 1 of 1 contains:

- 1 - Healthy Climate™ UVO3 germicidal lamp unit
- 1 - UVO3 bulb
- 1 - UVC bulb (UVO3-2000 only. UVO3-2000 contains one UVC bulb and one UVO3 bulb.)
- 1 - Power cord
- 1 - Remote door interlock switch with 5 ft(1.5m) power cord (UVO3-2000 Only)
- 1 - Self-adhesive gasket/template
- 1 - Installation instructions
- 5 - Sheet metal screws with lockwashers
- 2 - Warning labels for duct and blower door
- 1 - ATTENTION! warning sheet

#### Required Tools

- Electric drill
- Phillips screw bit or screwdriver
- 1" - 1.5" (25mm-38mm) holecutter
- 1/4" (6mm) drill bit
- Cotton cloth and rubbing alcohol
- Galvanized flexible elbows will be needed for any take-offs closer than 6 ft(1.8m) when flex duct is used.

#### ⚠ WARNING

Improper installation, adjustment, alteration, service or maintenance can cause property damage, personal injury or loss of life. Installation and service must be performed by a qualified installer or service agency.

#### ⚠ WARNING



Electric shock hazard. Can cause injury or death. Before attempting to perform any service or maintenance, turn the electrical power to unit OFF at disconnect switch(es). Unit may have multiple power supplies.

#### ⚠ WARNING



UVC light hazard. UVC light can cause temporary or permanent loss of vision, and sunburn. UVC light should only be viewed through the viewport. Take precautions to protect eyes and skin from direct exposure.

#### ⚠ WARNING

Ozone Hazard. Concentrations of ozone can have harmful respiratory effects. Do not operate this device without HVAC system blower operating.

**Note:** This device is not for sale in Canada. For more information on ozone producing units contact the Environmental Protection Agency at 1-800-438-4318, or visit [www.epa.gov/iedweb00/pubs/ozonegen.html](http://www.epa.gov/iedweb00/pubs/ozonegen.html).

## Dimensions/Specifications

### DIMENSIONS:

Model UVO3-500 - 11" L x 7" W x 2.5" H  
(279mm x 178mm x 63mm)

Model UVO3-1000 - 11" L x 7" W x 2.5" H  
(279mm x 178mm x 63mm)

Model UVO3-2000 - 17" L x 7" W x 2.5" H  
(432mm x 178mm x 63mm)

All models use 16"(406mm) bulb lengths.

### ELECTRICAL:

120 volt, 250V/3 Amp fuse, detachable 8' (2.4m), three-prong, power cord.

### POWER CONSUMPTION:

Model UVO3-500 - 144 Watts (Magnetic Ballast)

Model UVO3-1000 - 60 Watts (Electronic Ballast)

Model UVO3-2000 - 120 Watts (Electronic Ballast)

### DEVICE OPERATING TEMPERATURE:

45° F - 150° F (7° C - 65° C) Outside of duct.

### ACCESSORIES:

Remote Door Interlock Switch (Standard with UVO3-2000. Optional for UVO3-500 and UVO3-1000. Lennox Part No. 64X53.)

### LISTINGS:

FIFRA (Federal Insecticide Fungicide Rodenticide Act)

- File No. 73316

Class II Medical Device

Specifications subject to change without notice.

### MODEL UVO3-500/1000

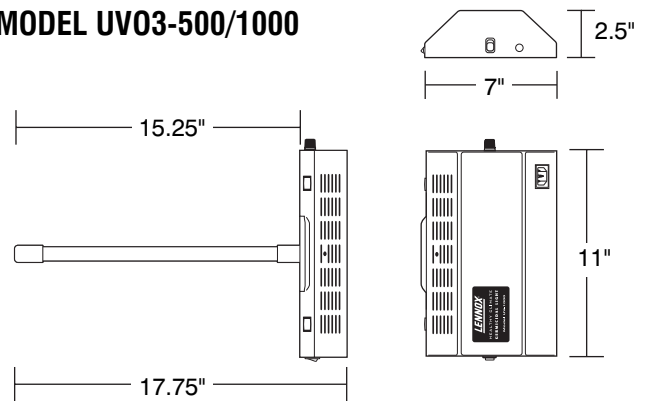

### MODEL UVO3-2000

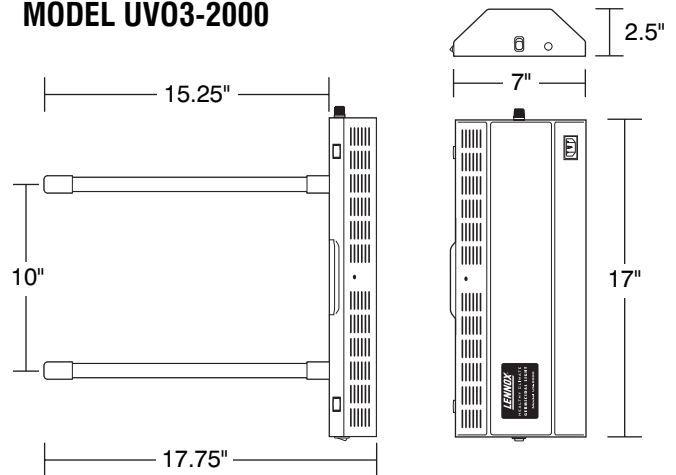

## Clearances and Requirements

### SELECTING AN INSTALLATION LOCATION

This device has been designed to fit into a wide variety of locations. Choose a location with enough clearance (see Fig. 1) to allow the UVC bulb to be removed and replaced easily. Be sure to choose a location that is easy to access for maintenance and that has a 120V power supply nearby.

Install the device in the return air duct, at the furnace, near the HVAC coil, or in the supply air duct. Allow 16"(406mm) in-duct clearance. Ensure no plastic parts or wire insulation are exposed to UVC light. Do not install where light can be seen after installation.

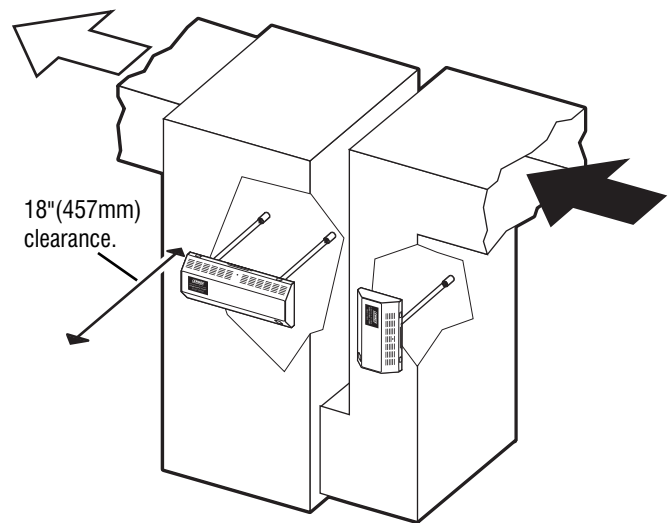

Fig. 1 Install the device near a cooling coil to reduce mold and bacteria in the coil fins, drain pans, and surrounding surfaces.

### ⚠ CAUTION



#### Device Orientation.

Do not install device with vent holes facing down. This is a violation of UL 1598.

## Clearances and Requirements

### SPECIAL INSTALLATION NOTES:

- Do not install in closet return applications.
- Do not install in rooftop/outdoor applications.
- Do not expose wiring or plastic parts to UVC light.
- Do not install device with vents facing down.
- Do not install device beneath a humidifier or source of water.
- Do not install in systems where other ozone producing devices are present.
- Do not install in systems where electronic air cleaners are present.

### **⚠ WARNING**

#### **Ozone Producing Devices.**

Do not operate this device in systems with electronic air cleaners. These devices operated together could result in harmful concentrations of ozone.

The Healthy Climate™ germicidal lamp must be installed a minimum of 6 ft(1.8m) away from plastic materials, filter material, cooling drain pans, flexible duct, etc., which are in direct line of sight .

Flexible duct installation with less than 6 ft(1.8m) clearance between the light and the flex duct must have a 90 degree metal elbow installed to protect the duct from direct UVC light exposure.

If the plastic is not in direct line of sight, a minimum of 3 ft(.9m) is required.

If space limitation prevents the installation from meeting the above requirements, all plastic material, cooling drain pans, etc., must be protected from direct UVC light using aluminum foil tape.

### **⚠ CAUTION**

#### **UVC Light May Degrade Plastic and Rubber.**

This device should not be mounted where it can expose plastic drain pans, wire insulation, flex duct, or other plastic/rubber components to UVC light.

### **⚠ CAUTION**

**Sharp Edge Hazard.** Be careful of sharp edges on device and HVAC equipment while installing the device. Personal injury may result.

## Installation

### MOUNTING THE DEVICE (Fig. 2)

Draw a level line positioned where the top of the device is to be located. Align the top of the self-adhesive gasket to the duct. Use the gasket as a template for drilling the viewport and bulb holes. Two bulb holes are required for Model UVO3-2000. Use a drill bit or holecutter to make the 1"(25mm) bulb hole(s) required. Use a 1/4"(6mm) drill bit for drilling the viewport hole.

Remove the cover of the device and attach the base to the gasket and duct using included sheet metal screws. For installations on duct-board use appropriate mounting method.

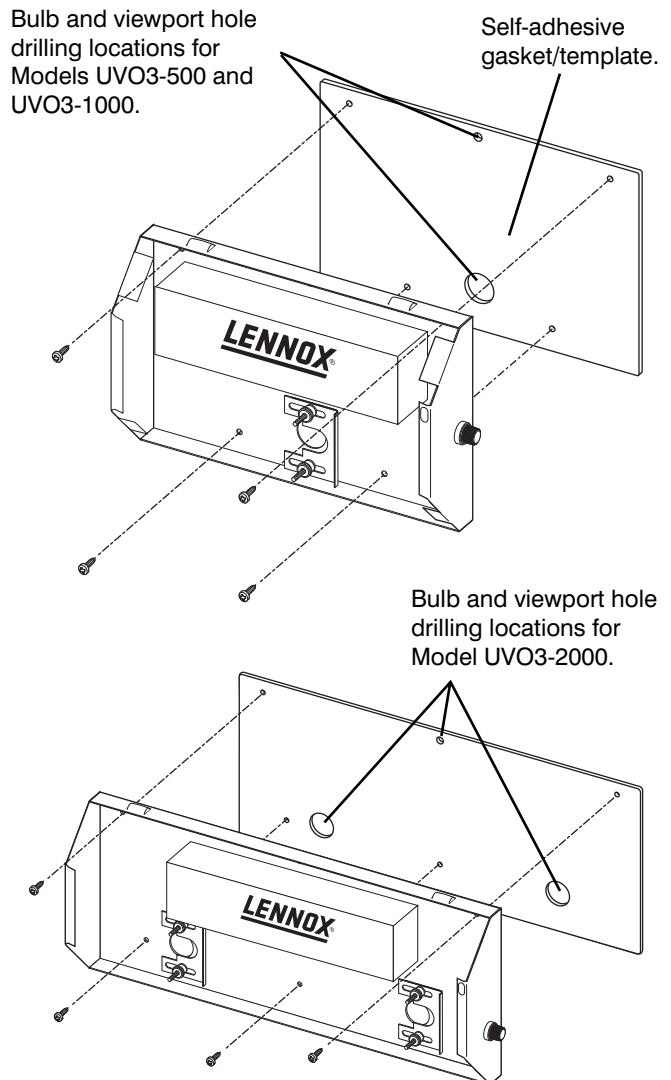

**Fig. 2** Attach self-adhesive gasket to the duct, drill required bulb and viewport holes, and mount device to the duct with included sheet metal screws.

## Installation

### INSTALLING THE BULB(s) (Fig. 3)

Once the holes have been drilled insert the bulb and slide the retaining bracket over the retaining lip of the bulb. The bulb seals against the base of the unit with an o-ring which prevents air leaks.

The slide bracket is tightened with two knurled nuts. Tighten each nut until the bulb is securely fastened.

**Note:** Do not damage wires on outside of bulb(s) during installation.

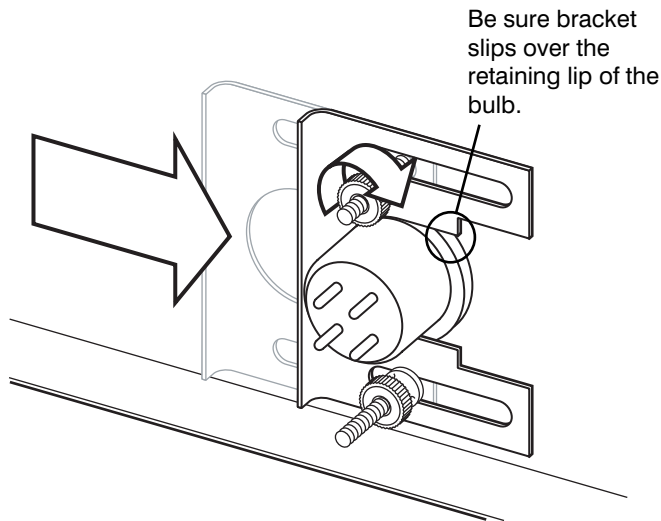

Fig. 3 Insert bulb and fasten with retaining bracket.

### HARNESS CONNECTION (cont'd)

tern. **Note:** *The connector pattern is not symmetrical. If the connector does not attach easily, rotate it 90 degrees and try again.*

Attach and close the cover to complete the installation. The device is now ready to be connected to 120V power and switched on. Verify operation by looking through the viewport. The bulb should be radiating a bright blue light. **Do not attempt to view the bulb directly.**

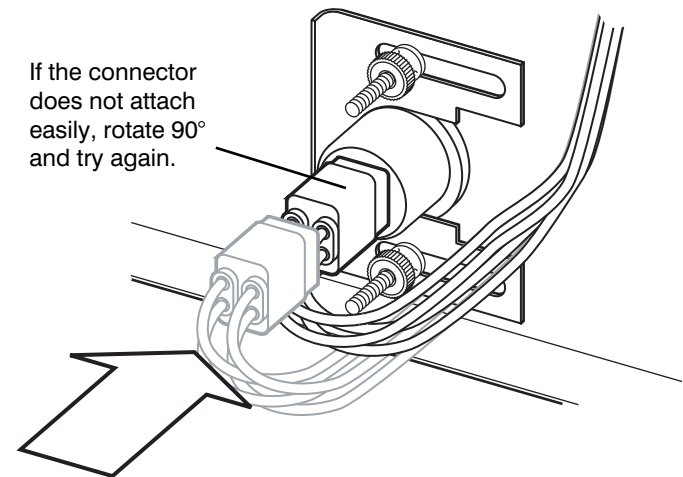

Fig. 4 Attach connector to bulb.

#### ⚠ CAUTION

##### Clean bulbs prior to installation.

Failure to clean bulb(s) could shorten their lifespan. Use rubbing alcohol and cotton cloth to remove dirt and fingerprints.

#### ⚠ WARNING

##### Mercury Hazard. Do Not Break.

Each UVC bulb contains a small amount of Mercury. In case of breakage use proper disposal techniques on page 7.

#### ⚠ WARNING



**UVC light hazard.** UVC light can cause temporary or permanent loss of vision, and sunburn. UVC light should only be viewed through the viewport. Take precautions to protect eyes and skin from direct exposure.

### WIRING INSTRUCTIONS

The UVO3 germicidal lamp **MUST BE** wired to cycle with the air handler blower motor as outlined below.

Option  Install an air pressure fan interlock switch (catalog no. 68E04 - minimum current rating of 120V at 3 amps). Switch must be wired in series with power to UVC device. Change plastic pressure switch tubing to metal to avoid UVC degradation. See diagram on page 6.

## Installation

### WIRING INSTRUCTIONS (cont'd)

Option  Install a current sensing relay (catalog no. 68P92 - minimum current rating of 120V at 3 amps) and a 120V relay [catalog no.37628 (encased wiring) or 58H23 (non-encased wiring)]. Relays should be wired in series with power to the UVC device. See diagram on page 6.

Further contractor questions concerning wiring of the Healthy Climate™ germicidal lamp should be directed to Lennox' Application Department.

### WARNING



**Electric shock hazard.** Can cause injury or death. Before attempting to perform any service or maintenance, turn the electrical power to unit OFF at disconnect switch(es). Unit may have multiple power supplies.

### INSTALL REMOTE DOOR INTERLOCK SWITCH

(Standard with UV03-2000. Optional for UV03-500, UV03-1000. Lennox Part No. 64X53.)

Mount the remote door interlock switch so that power to the device is automatically disconnected anytime the air handler access panel is opened.

1. Remove cap as shown in Fig. 5.
2. Insert remote door interlock switch wire through hole. Secure with strain relief. Install male and female connector to remote door interlock switch wires and connect to UVC light.
3. Mount remote door interlock switch and actuator to access panel opening.
4. Check operation. Device should turn off when access panel is opened.

**Note:** Remote door interlock switch includes 5 ft(1.5m) 120V power cord with custom connectors. If device is installed more than 5 ft(1.5m)

### REMOTE DOOR INTERLOCK SWITCH (cont'd)

away from remote door interlock switch, field wiring will be required in accordance with national and local codes.

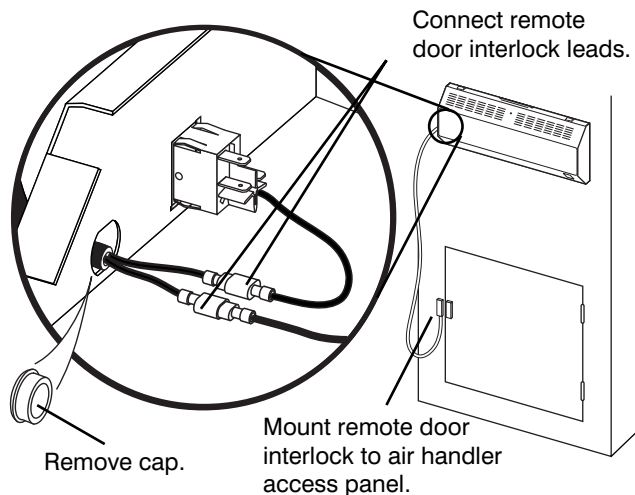

Fig. 5 Remote door interlock switch installation.

### WARNING LABEL APPLICATION

Attach warning labels to duct and air handler access panel so they are clearly visible.

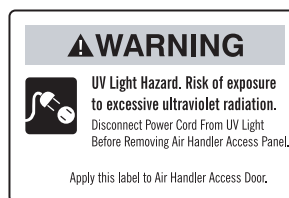

Fig. 6a Attach power disconnect label to air handler access panel.

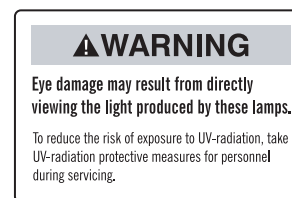

Fig. 6b Attach UVC warning label to ductwork adjacent to device location.

### Operation

For optimal performance, continuous operation of the UVC germicidal lamp and the air handler blower is recommended. IF continuous operation of the air handler is NOT selected, the UVC germicidal & O3 lamp MUST BE cycled with the air handler blower motor to avoid a build up of ozone. Continuous operation of the air handler blower motor and UVC germicidal lamp allows maximum exposure of airborne bioaerosols to the UVC light. This also promotes maximum filtration of the air and prevention of thermal stratification (hot at the ceiling, cool on the floor).

# Installation

## Model UVO3-500, UVO3-1000 Internal Wiring

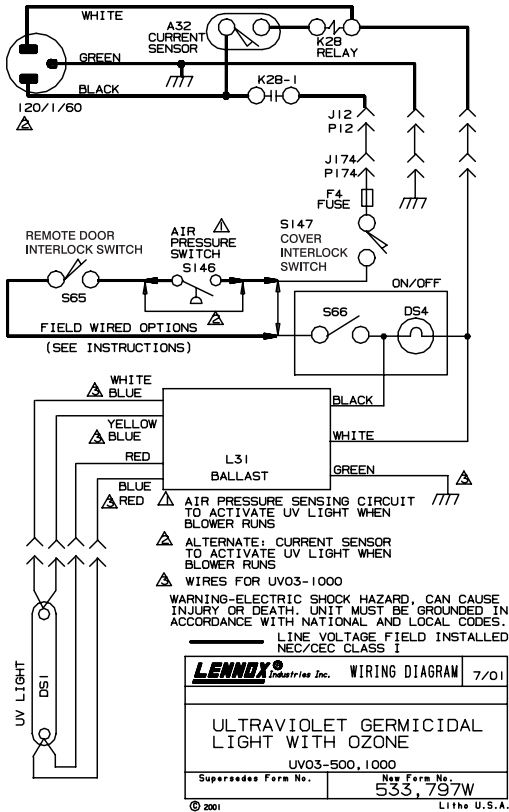

## Model UVO3-2000 Internal Wiring

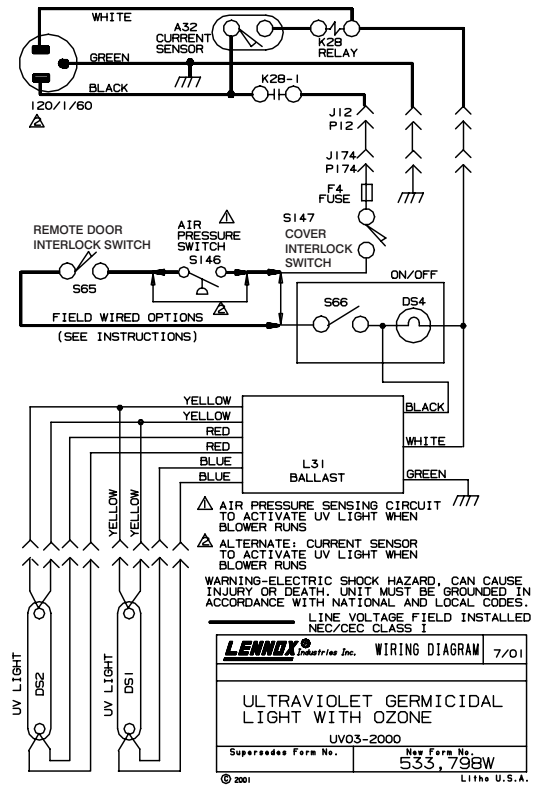

### CHECKLIST FOR COMPLETE INSTALLATION AND SAFETY ITEMS:

- All items were included in the shipping box and have been installed (see Shipping and Packing List).
- Safety label installed on door to air handling unit. (See Fig. 6a)
- Safety label installed on duct next to UVC germicidal lamp. (See Fig. 6b)
- Turn off room lights while the UVC germicidal light is operating and the access panels are in place. Make sure that blue light IS NOT visible through supply or return air grilles, holes in ducts, leaks around access panels, etc.) If blue light is visible, leaks around doors or panels must be sealed or UVC light must be repositioned so that no light is visible. **If it is not possible to completely avoid exposure to UVC light, device must be removed.**
- Explained to customer danger of viewing UVC germicidal light. "UVC light is like looking at the sun, you should not look at the sun and you MUST NOT look at the UVC light. Looking at the blue light can result in severe eye damage and/or sunburn."
- Checklist has been filled out and left with homeowner.

All instructions and safety instructions have been followed and the checklist is completed.

Installation Technician Signature: \_\_\_\_\_

Date: \_\_\_\_\_

## Maintenance

The bulb and external fuse are the only user serviceable parts of this device. For all other maintenance, contact a qualified HVAC technician.

### IF THE BULB DOES NOT ILLUMINATE

1. Check power cord for the presence of 120V.
2. Turn off power and remove access cover.
3. Check 3A fuse for conductivity. Replace fuse if necessary and determine the cause of the failure.
4. Check and ensure that the bulb connector is securely attached to the bulb.
5. Unplug the connector to the bulb. Check for resistance across each narrow spaced pair of bulb contact pins. Replace the bulb if an open circuit is found.
6. If steps 1 through 5 pass inspection then the ballast may be at fault. Replace the ballast.

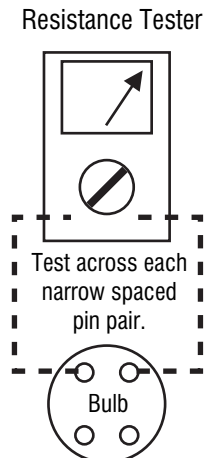

### FUSE REPLACEMENT

1. Unscrew the knob marked "Fuse" and remove fuse.
2. Install new fuse and screw knob back in place. Use a 250V/3 Amp fuse only.

### BULB REPLACEMENT(Annually)

The bulb should be replaced annually even if it appears to be operating normally. UVC energy production diminishes over time.

1. Obtain the correct replacement bulb for your Healthy Climate™ model.
2. Disconnect power to the device.
3. Open the cover of the device. *Allow bulb to cool 10 minutes before touching.*

### BULB REPLACEMENT (cont'd)

4. Disconnect the bulb connector.
5. Unscrew the two knurled knobs of the bulb retaining bracket and slide the bracket away from the bulb retaining lip.
6. Carefully remove the bulb and replace it with the new bulb. Be sure to clean the bulb of dust and fingerprints prior to installation. See page 4.
7. Slide the retaining bracket back in place and tighten knurled knobs.
8. Reconnect bulb connector.
9. Close the cover of the device and reconnect power.
11. Use the viewport to verify operation.

### BULB DISPOSAL

Each UVC bulb contains a small amount (10 mg of Mercury). Spent bulbs must be disposed of appropriately as you would a typical fluorescent lamp (25-50 mg of Mercury). Dispose of spent bulbs one of the following ways:

1. Through your local hazardous waste disposal facility.
2. Returning to the address below in the same container in which you received your replacement bulbs.

**Healthy Climate™ Bulb Reclamation**  
**1112 Industrial Park Drive**  
**Royse City, TX 75189**

### PROPER CLEAN-UP TECHNIQUE IN CASE OF BULB BREAKAGE

- Wear protective gloves, eyewear and mask.
- Sweep the broken glass and debris into a plastic bag, seal the bag, and dispose of properly. Contact your local waste management office for proper disposal.
- **Do not use a vacuum cleaner. Do not incinerate.**

### ⚠ WARNING

#### Burn Hazard.

During replacement, allow bulbs to cool 10 minutes before removing them. Personal injury may result.

### ⚠ WARNING

#### Mercury Hazard. Do Not Break.

Each UVC bulb contains a small amount of Mercury. In case of breakage use proper disposal techniques.

## Replacement Parts

No.	Description	UV03-500	UV03-1000	UV03-2000
1	Power Cord Receptacle	64X46	64X46	64X46
2	Slide Bracket Springs (2)	64X35	64X35	64X35
3	Slide Bracket	64X33	64X55	64X55
4	Knurled Nuts (2)	64X34	64X34	64X34
5	Base Gasket/Template	64X42	64X42	64X64
6	Base with Studs	64X31	64X54	64X60
7	Access Hole Cap	72X85	72X85	72X85
8	Lighted On/Off Switch	64X50	64X50	64X50
9	Ballast	64X38	64X58	64X62
10	Viewport Shield	64X43	64X43	64X43
11	Cover Interlock Switch	64X45	64X45	64X45
12	Fuseholder	64X48	64X48	64X48
13	Fuse	64X49	64X49	64X49
<b>Replacement Parts Not Illustrated</b>				
	Complete Unit w/Bulb(s)	46X86	46X88	46X90
	UVC Replacement Bulb	64X36 <sup>1</sup>	64X56 <sup>1</sup>	64X56 <sup>1,2</sup>
	UV03 Replacement Bulb	64X37	64X57	64X57 <sup>2</sup>
	Bulb O-Ring	64X41	64X41	64X41
	Cover with Label	64X32	64X32	64X61
	Cover Label	64X39	64X59	64X63
	Installation/Owners Manual	64X40	64X40	64X40
	Power Cord	64X47	64X47	64X47
	On/Off Label	64X51	64X51	64X51
	Fuse Label	64X52	64X52	64X52
	Remote Door Interlock Switch	64X53	64X53	64X53
<b>Optional Parts</b> (See wiring options $\triangle 1$ and $\triangle 2$ .)				
	Air Pressure Interlock Switch	68E04	68E04	68E04
	Current Sensing Relay	68P92	68P92	68P92
	120V Relay (encased)	37628	37628	37628
	120V Relay (non-encased)	58H23	58H23	58H23

<sup>1</sup> UVC replacement bulbs can be substituted for the UV03 replacement bulbs if customer desires.

<sup>2</sup> The Model UV03-2000 uses (1) 64X56 and (1) 64X57. Two replacement bulbs are required.

## Warranty

### LIMITED WARRANTY

Your Lennox Healthy Climate™ Germicidal Light is expressly warranted for two (2) years from date of installation to be free from manufacturing defects. This warranty does not cover the lamp(s), which must be replaced annually to ensure effective operation.

The manufacturer's exclusive obligation under this warranty shall be to supply, without charge, a replacement for any covered component of the Germicidal Light which is found to be defective within a two (2) year period. Defective parts must be returned no later than thirty (30) days after the failure by you to the installing contractor together with the model number, serial number, and installation date of the Germicidal Light. You must pay shipping charges and all other costs of warranty service. Lennox will not pay labor involved in diagnostic calls or in removing, servicing or replacing parts.

THIS WARRANTY SHALL NOT OBLIGATE THE MANUFACTURER FOR ANY LABOR COSTS AND SHALL NOT APPLY TO DEFECTS IN WORKMANSHIP OR MATERIALS FURNISHED BY THE INSTALLING CONTRACTOR AS CONTRASTED TO DEFECTS IN THE GERMICIDAL LIGHT ITSELF.

IMPLIED WARRANTIES OF MERCHANTABILITY OR FITNESS FOR A PARTICULAR PURPOSE SHALL BE LIMITED IN DURATION TO THE AFORESAID TWO (2) YEAR PERIOD. THE MANUFACTURER'S LIABILITY FOR INCIDENTAL OR CONSEQUENTIAL DAMAGES, OTHER THAN DAMAGES FOR PERSONAL INJURIES, RESULTING FROM ANY BRANCH OF THE AFORESAID IMPLIED WARRANTIES OR THE ABOVE LIMITED WARRANTY IS EXPRESSLY EXCLUDED. THIS LIMITED WARRANTY IS VOID IF DEFECT(S) RESULT FROM FAILURE TO HAVE THIS UNIT INSTALLED BY A QUALIFIED HEATING AND AIR CONDITIONING CONTRACTOR. IF THE LIMITED WARRANTY IS VOID DUE TO FAILURE TO USE A QUALIFIED CONTRACTOR, ALL DISCLAIMERS OF IMPLIED WARRANTIES SHALL BE EFFECTIVE UPON INSTALLATION.

Some states do not allow limitations on how long an implied warranty lasts or the exclusion or limitation of incidental or consequential damages, so the above exclusion or limitations may not apply to you.

This warranty gives you specific legal rights and you may also have other rights which vary from state to state.

Contact your local Lennox® dealer to order replacement parts.  
For the Lennox dealer nearest you, dial 1-800-9Lennox.  
Visit us at <http://www.Lennox.com>

