

## GAS CHANGEOVER KIT

### INSTALLATION INSTRUCTIONS FOR NATURAL TO REGULATED LP/PROPANE GAS CHANGE-OVER KIT (45L88 / 165296403) USED WITH 250,000 AND 300,000 Btuh UNIT HEATERS

#### **⚠ WARNING**

This conversion kit is to be installed by a licensed professional service technician (or equivalent) or other qualified agency in accordance with the manufacturer's instructions, all codes and requirements of the authority having jurisdiction in the USA, and the requirements of the CSA-B149 installation codes in Canada. If the information in these instructions is not followed exactly, a fire or explosion may result causing property damage, personal injury or loss of life. The qualified agency performing this work assumes responsibility for this conversion.

#### Shipping and Packing List

##### Package 1 of 1 contains:

- 12- Tapered burner orifices #53 (.0595") 1/8" NPT
- 1- Honeywell VR8305 series propane gas valve
- 2- Unit conversion stickers
- 12- Turbulator assemblies
- 2- Retainers
- 6- 18 X 1/2 SDST Screws

#### Application

The natural to regulated LP/propane gas changeover kit (45L88 / 165296403) is for use on LF24/SEP-250 and LF24/SEP-300 unit heaters.

#### **⚠ WARNING**

##### Danger of explosion.

There are circumstances in which odorant used with LP/propane gas can lose its scent. In case of a leak, LP/propane gas will settle close to the floor and may be difficult to smell. An LP/propane leak detector should be installed in all LP applications.

#### Installation

- 1 - Set thermostat to lowest setting. The gas supply must be shut off prior to disconnecting the electrical power and proceeding with the conversion.

- 2 - Turn automatic gas valve knob to **OFF** position.
- 3 - Disconnect gas supply from gas valve. Disconnect wiring at gas valve. Use 5/16" driver to remove four screws which secure the manifold/gas valve assembly. Remove manifold/gas valve assembly.
- 4 - Remove existing burner orifices. Apply pipe thread compound to threads of orifices provided in kit. Install orifices in manifold. See figure 1.

*IMPORTANT - Do not allow pipe thread compound to enter orifice bore.*

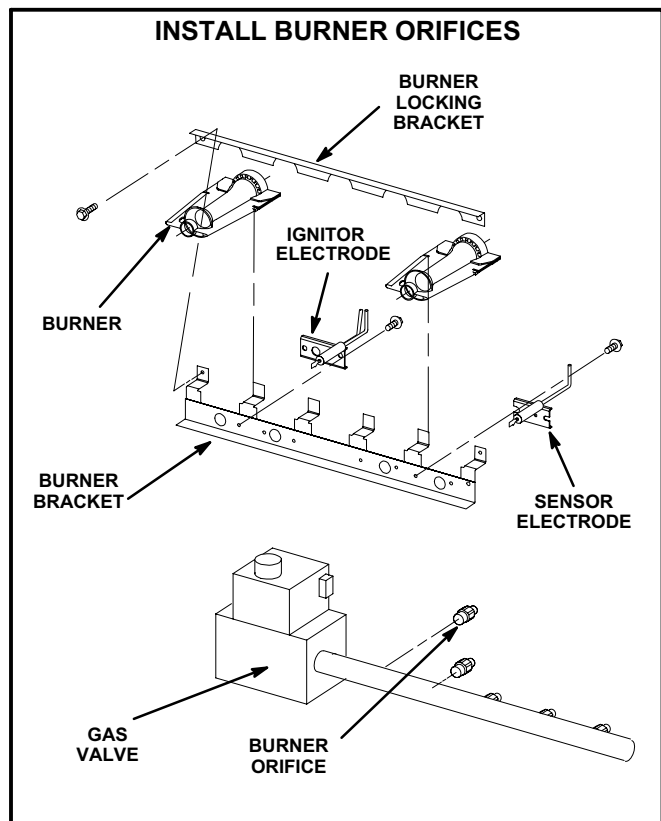

FIGURE 1

- 5 - Remove existing gas valve (for natural gas **ONLY**) from the manifold.
- 6 - Install new gas valve supplied in the kit.

*IMPORTANT - The new gas valve changeover is for LP propane gas only.*

- 7 - Disconnect ignition and sensor wires from electrodes on burner bracket.
- 8 - Use 5/16" driver to remove two #10-16 X 5/8" HWHSMS screws which secure the burner bracket.
- 9 - Remove the burner assembly from the burner box.
- 10 - Use required number of turbulators for the unit heater: ten turbulators for LF24/SEP-250; twelve for LF24/SEP-300.

**IMPORTANT - When handling turbulators, wear gloves and goggles and NIOSH approved dust and mist respirator. Wash exposed skin areas with soap and warm water after handling.**

- 11 - Carefully insert turbulator assemblies into heat exchanger tubes. Orient as shown in figure 2.

**NOTE - Turbulators are brittle - take care in handling.**

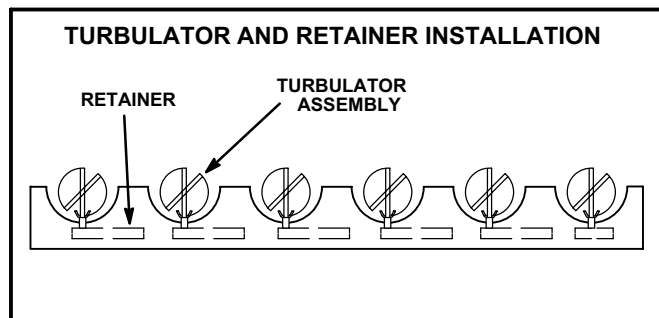

**FIGURE 2**

- 12 - Install retainers on vest panel to secure the turbulator. Fasten each retainer with three #8-18 X 1/2" SDST self-drilling screws supplied in the kit.
- 13 - Reinstall burner assembly in burner box using two #10-16 X 5/8" HWHSMS screws and 5/16" driver.
- 14 - Reconnect ignition wire and sensor wire.
- 15 - Reinstall manifold/valve assembly. Secure with four #10-16 X 5/8" HWHSMS screws.
- 16 - Connect gas valve wiring.
- 17 - Connect gas supply to gas valve.
- 18 - Restore gas to unit.

**IMPORTANT - Carefully check all piping connections. DO NOT use matches, candles, open flame or other means of ignition to check for gas leaks. Use a soap solution or other preferred means.**

- 19 - Affix unit conversion stickers provided in the kit adjacent to unit rating plate.
- 20 - Affix new lighting instructions sticker supplied in the kit. Place it over the top of the existing lighting instructions sticker on the unit.

|   |                  |
|---|------------------|
|    | <h2>CAUTION</h2> |
| <p><b>Some soaps used for leak detection are corrosive to certain metals. Carefully rinse piping thoroughly after leak test has been completed. Do not use matches, candles, flame or other sources of ignition to check for gas leaks.</b></p> |                  |

## Start-Up And Adjustments

BEFORE LIGHTING, smell all around the appliance area for gas. Be sure to smell next to the floor because some gas is heavier than air and will settle on the floor.

Use only your hand to push in or turn the gas control knob. Never use tools. If the knob will not push in or turn by hand, do not try to repair it, call a qualified service technician. Force or attempted repair may result in a fire or explosion.

### A - Placing Unit In Operation:

**IMPORTANT** - Follow the lighting instructions provided on the unit. If lighting instructions are not available, see section below.

LF24 and SEP unit heaters are equipped with an automatic spark ignition system. **DO NOT** attempt to manually light burners on these furnaces. Each time thermostat calls for heat, the burners will automatically be lit.

- 1 - Make sure thermostat is set below room temperature and power is turned off to unit.
- 2 - This appliance is equipped with an ignition device which automatically lights the burners. **DO NOT** try to light the burners by hand.
- 3 - Turn knob on gas valve clockwise to **OFF**. Do not force.
- 4 - Wait 15 minutes to clear out any gas. If you then smell gas, immediately call your gas supplier from an outside phone. Follow the gas supplier's instructions. If you do not smell gas go to next step.
- 5 - Turn knob on gas valve counterclockwise to **ON**.
- 6 - Turn on all electrical power to unit.
- 7 - Set thermostat to desired setting.

**NOTE** - When unit is initially started, steps 1 through 7 may need to be repeated to purge air from gas line.

### B - Gas Pressure Adjustment

- 1 - Check gas line supply pressure with unit firing at maximum rate. A minimum of 11.0" w.c. should be maintained.
- 2 - After gas line pressure has been checked and adjusted, check manifold pressure at the pressure tap on the outlet side of the gas valve. The correct manifold pressure for LP/propane gas is given in table 1. Refer to figure 3 for gas manifold pressure adjustment screw location.

TABLE 1

| GAS MANIFOLD PRESSURES (PROPANE) |            |               |
|----------------------------------|------------|---------------|
| Unit Model                       | 0-2000 ft. | 2000-4500 ft. |
| LF24/SEP-250                     | 9.0        | 8.7           |
| LF24/SEP-300                     | 9.0        | 9.0           |

**NOTE** - In the USA, refer to the unit installation instructions for gas manifold pressures at elevations above 4500 ft.

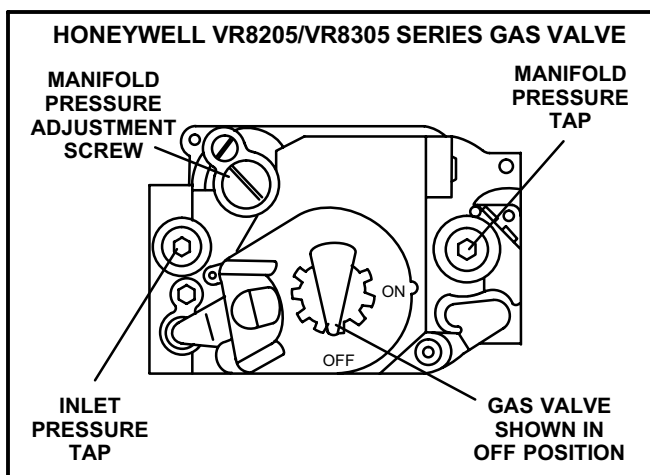

FIGURE 3

### C - Burner

Start burner and allow to operate for a few minutes. Observe flame. Flame should be predominantly blue (with some yellow), strong and steady. Flame should burn continuously from all burners.

### D - Means To Verify Gas Rate

Input must not exceed amount shown on unit rating plate. In cases where gas is not metered, the service technician performing the conversion will need to supply the meter. Input may then be checked by the following method:

The utility company or LP/propane gas distributor may be contacted for the heating value of the gas. All other appliances should be shut off during the input check.

Locate meter just upstream in regulated pressure (10.0" w.c. to 13.0"w.c.). To check the Btu input rate, the dial hand on the gas meter should be timed for at least one revolution, using the one cubic foot dial to assure accurate measurements, use temperature and pressure correction factors for the meter.

To determine the number of seconds required for the flow of one cubic foot of gas, use the following formula:

$$\frac{\text{(BTUH CONTENT)} \\ \text{HEATING VALUE OF GAS X 3600}}{\text{UNIT BTUH INPUT}}$$

Example:      2500 BTU gas  
                  Unit input 225,000 BTUH

Seconds for one cubic foot =

$$\frac{2500 \times 3600}{225,000} = 40 \text{ seconds}$$

### E - Ignition System

Check the normal operation sequence of the ignition system after conversion. See instruction manual supplied with the unit.

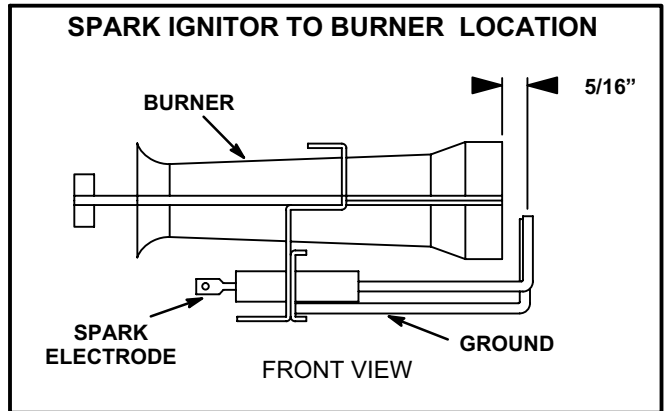

FIGURE 8