

**INSTALLATION INSTRUCTIONS FOR ENTHALPY SENSOR KIT  
(603364-35; 21Z09) USED WITH ECONOMIZERS**

**⚠ WARNING**

Improper installation, adjustment, alteration, service or maintenance can cause property damage, personal injury or loss of life. Installation and service must be performed by a qualified installer, service agency or the gas supplier

**⚠ CAUTION**

Danger of sharp metallic edges. Can cause injury. Take care when servicing unit to avoid accidental contact with sharp edges.

**Shipping and Packing List**

**Package 1 of 1 contains:**

- 1- Sensor
- 2- #6-32 X 7/8" Screws
- 1- P104 Wiring harness (used for outdoor air sensing only)
- 1- P105 Wiring harness (used for return air sensing only)
- 1- J105 Wiring harness (used on KG/KC/KH092-300S only)
- 1- Bracket (used on LG/LC/KG/KC/KH 092-150 units only)
- 1- Wire tie
- 1- #10-16 X 5/8" SDST screw

**IMPORTANT** - Two kits must be installed if differential enthalpy sensing is specified.

Check packaging for shipping damage. Contact the last carrier immediately if any shipping damage is found.

**Application**

Sensors provide input to determine free cooling suitability. The enthalpy sensor provided in this kit senses both sensible temperature and humidity. See table 1 for usage.

This kit applies to LGM/LCM, LGH/LCH, KG/KC/KH, ZG/ZC/ZH, QG/QH/QC unit standard performance economizers and LGM/LCM/LGH/LCH high performance economizers. A separate kit is used for KG/KC/KH, ZG/ZC/ZH and QG/QH/QC high performance economizers.

Refer to economizer installation instructions.

**Note** - Differential sensor applications must use the same two sensors.

**TABLE 1**

No. Of Sensors	Outdoor Air Is Enabled For Free Cooling When:
1	OA enthalpy, A7, is less than free cooling set-point (single enthalpy).
2	OA enthalpy, A7, is less than RA enthalpy, A62 (differential enthalpy).*

\*Differential enthalpy not available with ZG/ZC/ZH and QG/QH/QC units.

**Install Sensors**

**Note** - Install the return air sensor before installing optional power exhaust dampers and gravity exhaust dampers. If gravity exhaust, power exhaust, or hoods are already installed, remove from unit.

- 1- Disconnect all power to unit.
- 2- Remove unit top back panel and retain screws. If economizer is already installed, remove hood.
- 3- Install sensors as shown in table 2.

**TABLE 2**

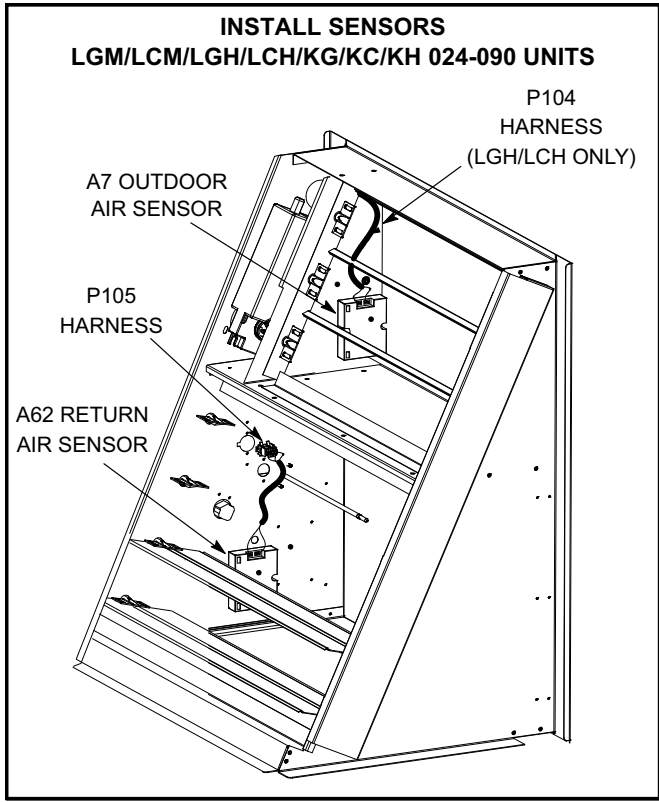
Sensors	Unit	Kit Harness Used:	Sensor Location
1	LG/LC 036-072	P104	Figure 1
	KG/KC/KH 024-090	None*	
2	LG/LC 036-072	P104, P105**	Figure 1
	KG/KC/KH 024-090	*P105, J105	
1	LG/LC 092-150	P104	Figures 2 and 4
	KG/KC/KH 092-150	None*	
2	LG/LC 092-150	P104, P105**	Figures 2 and 4
	KG/KC/KH 092-150	*P105, J105	
1	LG/LC 156-300	P104	Figure 3
	KG/KC/KH 156-300	None**	
2	LG/LC 156-300	P104, P105*	Figure 3
	KG/KC/KH 156-300	*P105, J105	
1	ZG/ZC/ZH	None*	Figure 5
2	***ZG/ZC/ZH	NA	NA
1	QG/QC/QH	None	Figure 6
2	***QG/QC/QH	N/A	N/A

\*P104 not used; disconnect S175, reconnect to A7.

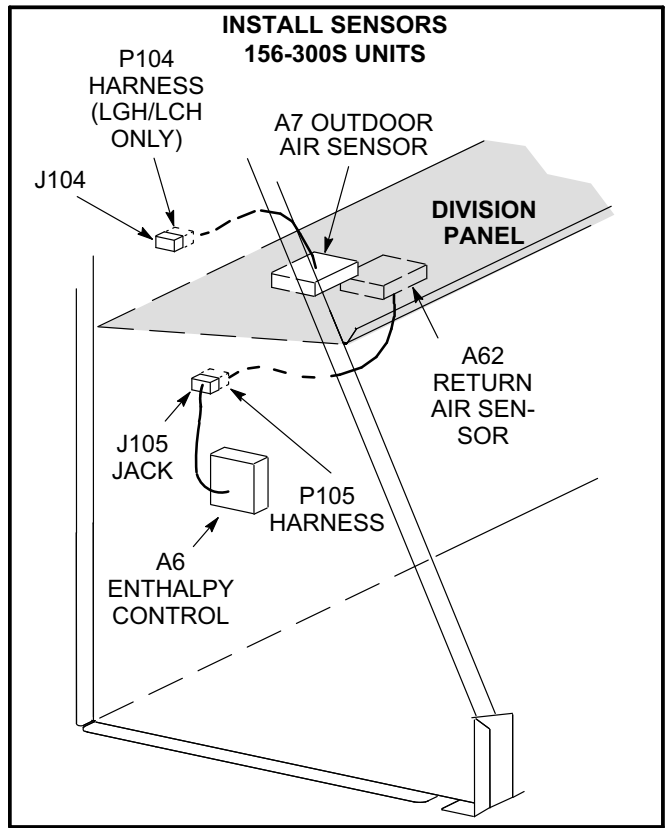
\*\*J105 provided in unit.

\*\*\*Differential enthalpy not available with ZG/ZC/ZH/QG/QC/QH units.

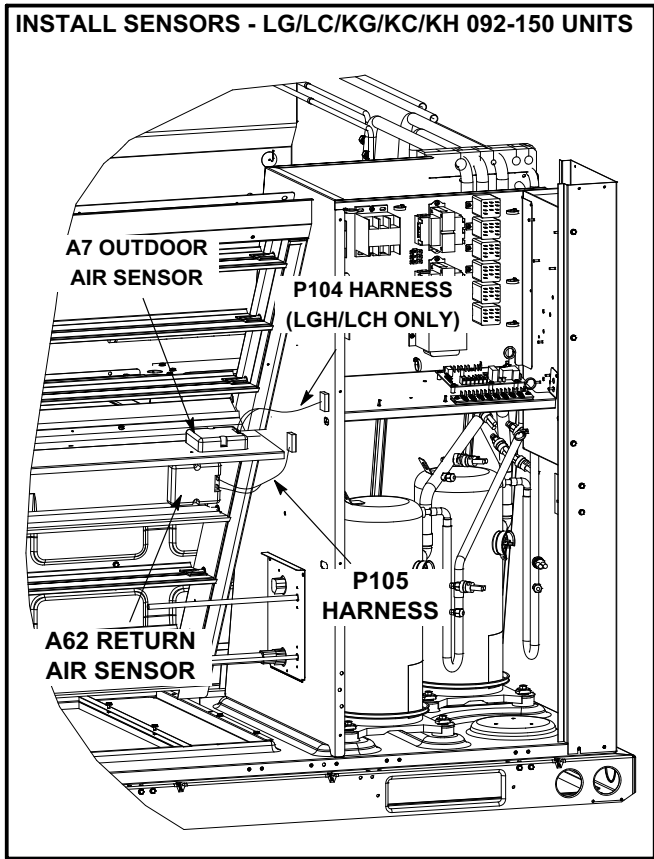




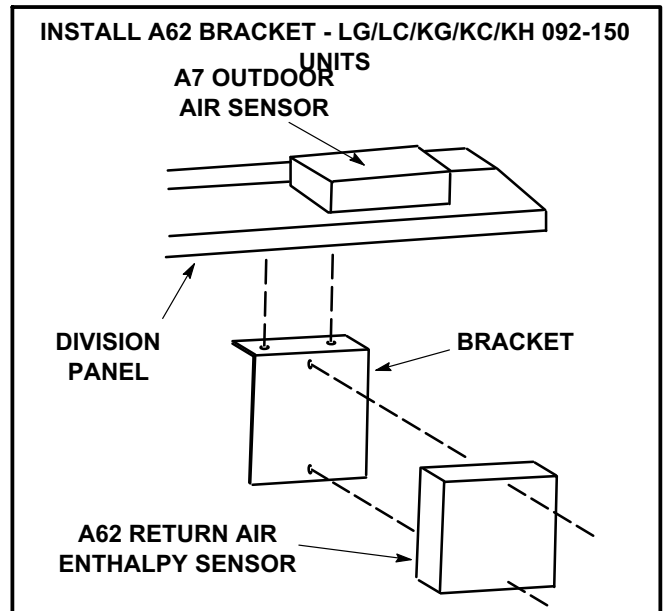
**FIGURE 1**



**FIGURE 3**



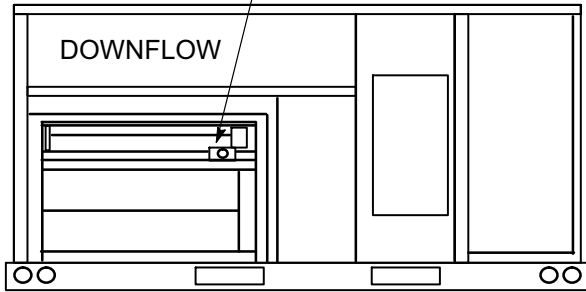
**FIGURE 2**



**FIGURE 4**

### INSTALL SENSOR - ZG/ZC/ZH 036-150 UNITS

- 1- Remove factory-installed S175 outdoor air sensible sensor and bracket.\*



\*036-060 SHOWN; 092-150 SIMILAR

- 2- Disconnect wiring to S175 and reconnect to A7 enthalpy sensor.
- 3- Install A7 enthalpy sensor using S175 bracket holes. Secure with screws provided in kit.

Note - All contents of kit may be discarded except for the sensor and screws. Harnesses are not used in this application.

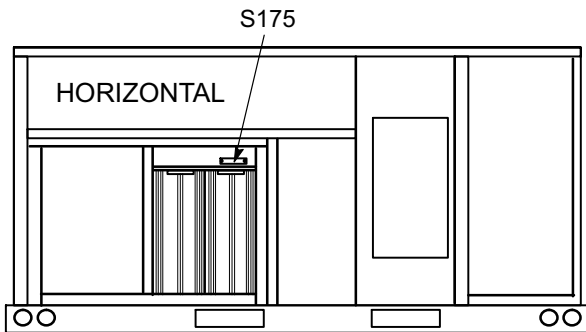


FIGURE 5

### Wire A7 Sensor

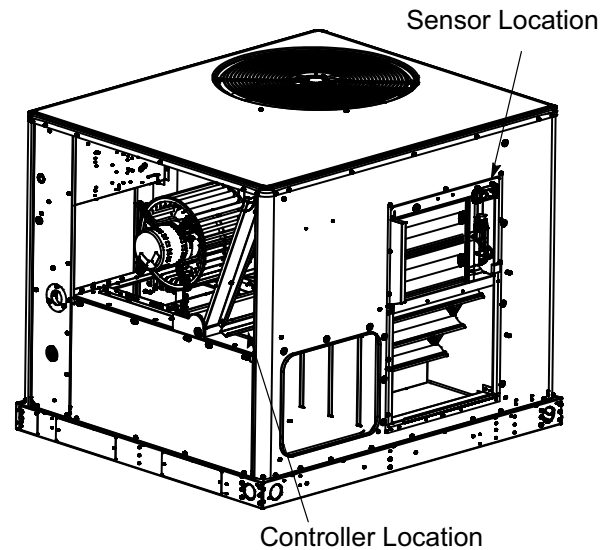
Note - S175 is factory-installed and wired in KG/KC/KH/ZG/ZC/ZH 024-300S economizers. Kit P104 harness is not used. When replacing S175 with an A7 enthalpy sensor, wire A7 with disconnected S175 wires.

- 1- Connect P104 harness plug to unit J104. See figure 1 for 024-090 units, figure 2 for 092-150 units, and figure 3 for 156-300S units.

Note - Wiring to sensor is shown on D or D1 economizer wiring section. D or D1 is located on the compressor access panel or packaged with economizer.

- 2- Connect the wires on the other end of the harness to A7 terminals S and + as marked on the wires. Make sure polarity is correct.

### INSTALL SENSOR - QG/QC/QH 036-150 UNITS



- 1- Install sensor in the location shown above.
- 2- Plug the red and black wires from the controllers "SO" and "SO+" terminals into the sensors + and - terminals.
- 3- Discard unused harnesses.

FIGURE 6

### Wire A62 Sensor - LG/LC/KG/KC/KH

Note - Discard J105 harness provided in kit when installing LGH/LCH units.

- 1- Connect P105 harness plug to unit J105. See figure 1 for 036-072 units, figure 2 for 092-150 units, and figure 3 for 156-300S units. On KG/KC/KH units refer to Wire A6 section in this instruction to install J105.

Note - Wiring to sensor is shown on D or D1 economizer wiring section. D or D1 is located on the compressor access panel or packaged with economizer.

- 2- Connect the wires on the other end of the harness to A62 terminals S and + as marked on the wires. Make sure polarity is correct.
- 3- Reinstall gravity exhaust damper, power exhaust, and outdoor air hood when applicable.

### Wire A6 Control - KG/KC/KH Units Only

- 1- Install J105 harness jack in panel as shown in figure 8 for 024-090 units, figure 9 for KG/KC/KH 092-150 units and figure 3 for 180-300S units.
- 2- Remove resistor between A6 enthalpy control terminals SR+ and SR. See figure 7.

- 3- Connect the two leads from the wire harness to SR+ and SR terminals on the A6 control. Note the labeling on the wires for correct wiring.
- 4- Turn A6 control setpoint dial completely clockwise to position "D". See figure 7.

**Prodigy 2.0 M3 Unit Controller Configuration**

Configure the Unit Controller for the enthalpy sensor use using the following menu:

Go to **SETUP / INSTALL** and navigage through the various setup questions until **Configuration ID 1** appears. Position **two** needs to set to either **S** for economizer - single enthalpy or **D** for economizer - dual enthalpy.

**Prodigy M4 Unit Controller Configuration**

Configure the unit through the mobile app. **Go to SETUP / RTU Menu > Setup Install** and navigate through the various setup questions until **Configuration ID 1** appears. Position **two** needs to be set to either **S** for economizer - single enthalpy or **D** for economizer - dual enthalpy

*Note - Refer to M4 Setup Guide provided with the unit for more info.*

**Operation**

Refer to Unit Controller manual for start-up and operation.

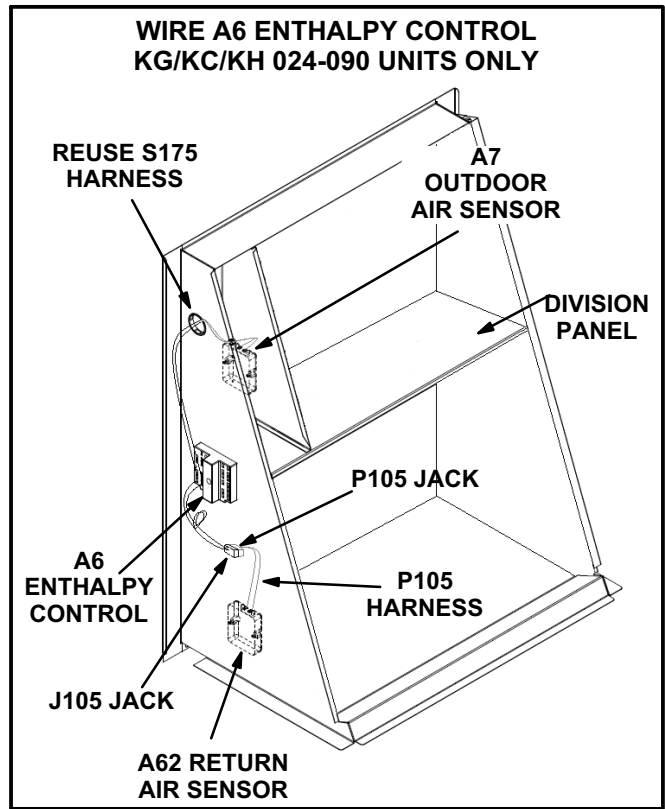


FIGURE 8

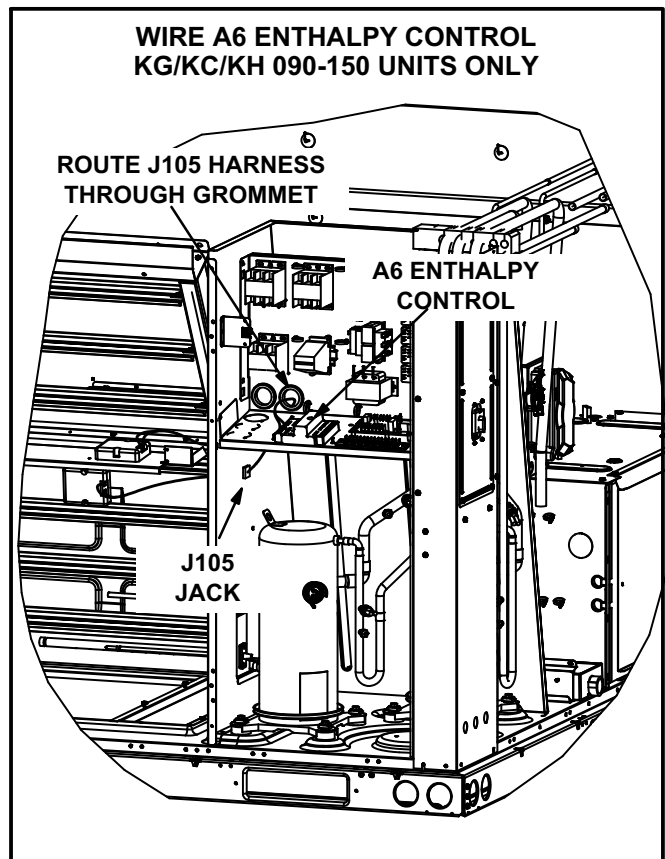


FIGURE 9

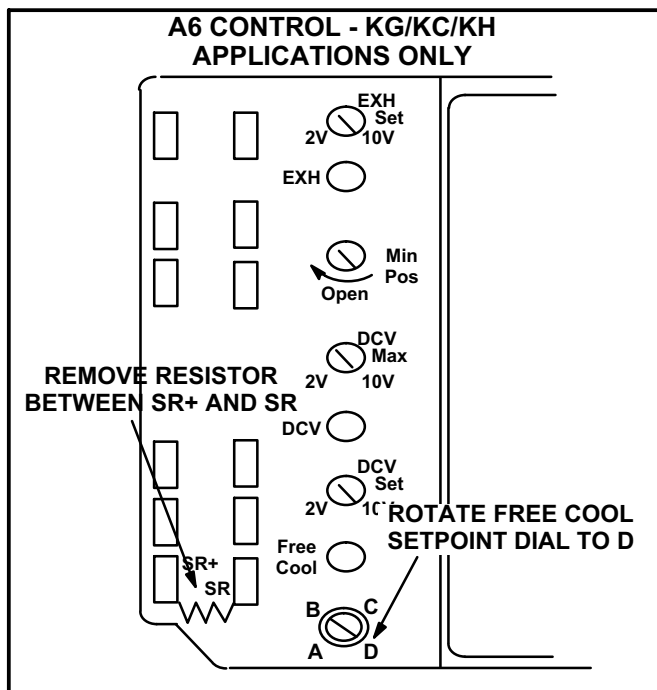


FIGURE 7