

POWER EXHAUST FANS

INSTALLATION INSTRUCTIONS FOR POWER EXHAUST FANS USED WITH LG/LC/KG/KC/KH 156-300 PACKAGED UNITS

Shipping and Packing List

75W92 & 93, 17J98, 22H90 & 91

Package 1 of 1 contains:

- 1- Power exhaust assembly
- 1- Metal box containing:
 - 2-K65/K231 Relays
 - 1-CAV Power harness
 - 1-VFD Power harness (2 in 22H90 & 91)
 - 2-Adapter harnesses (3 in 22H90 & 91)
 - 1-Rain shield
- 10-#10 Sheet metal screws
- 6-#6 Thread forming screws
- 1-Length of foam insulating tape
- 1-Snap bushing
- 1-Wire tie
- 17J98, 22H90, 22H91 Only:*
 - 1-Fuse block, 2-pole
 - 2-Fuses
 - 2-#8 Thread forming screws

Check packaging for shipping damage. Contact the last carrier immediately if any shipping damage is found.

Locate all other accessories to be installed. Install

accessories in the following order:

- 1-Outdoor Air or Economizer Dampers
- 2-Sensors
- 3-Power Exhaust Fans
- 4-Gravity Exhaust Dampers
- 5-Exhaust Hoods
- 6-Intake Hoods

Application

Power exhaust fans are applied to units equipped with an economizer in downflow air discharge. The power exhaust fan option cannot be used in horizontal air discharge applications.

Use table 1 to determine appropriate kit parts used on each unit. Discard unused harnesses, relays and fuses.

⚠ WARNING

Improper installation, adjustment, alteration, service or maintenance can cause property damage, personal injury or loss of life. Installation and service must be performed by a licensed professional HVAC installer or equivalent, service agency, or the gas supplier

TABLE 1

Unit	Voltage	Part #	CAT. #	Use Harnesses		Install Fuses	No. of Relays
CAV	Y (208/230)	606761-07	22H90	105680	(2)Adapter 606805 ²	Yes	1
CAV	G (460)	606761-08	22H91				
CAV	J (575) High SCCR	606761-06	17J98				
CAV	J (575) High SCCR	606761-03	75W92	106073 ¹	(2)Adapter 606805 ²	NA	1
CAV	M (380/420)	606761-04	75W93				
VFD	Y (208/230)	606761-07	22H90	105679 ⁴ 106765 ³	106724 ³	Yes	2
VFD	G (460)	606761-08	22H91				
VFD	J (575) High SCCR	606761-06	17J98				
VFD	J (575) High SCCR	606761-03	75W92	106072 ⁴	NA	NA	2
VFD	M (380/420)	606761-04	75W93				

¹On CE Units Only - cut terminals off of two leads as shown in wiring connection figures.

²Use only on older units equipped with 3-pin J18 and J24.

³LGM/LCM only.

⁴Not used on LGM/LCM.



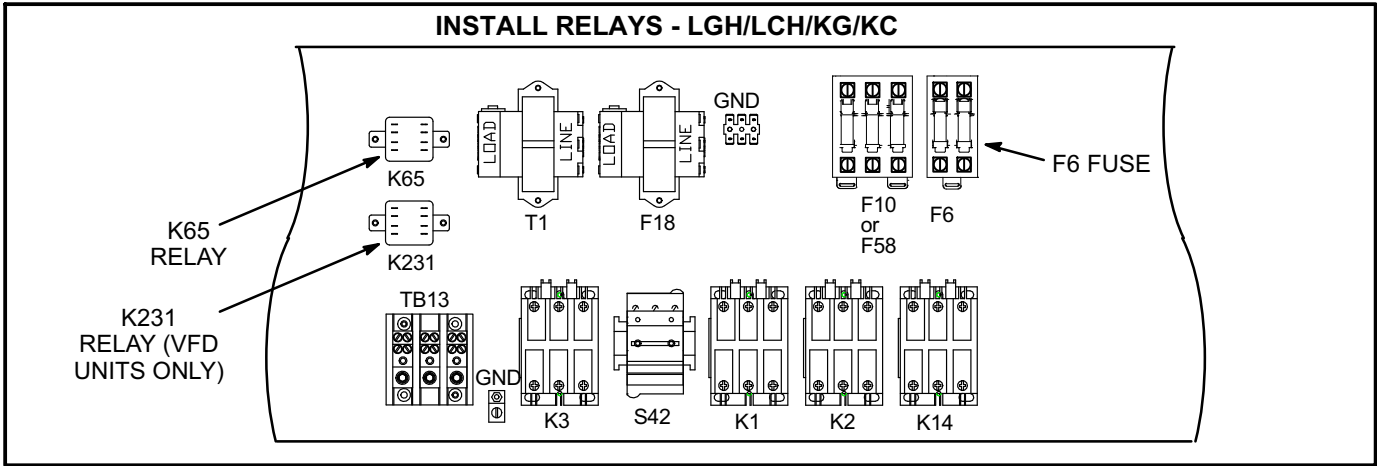

FIGURE 1

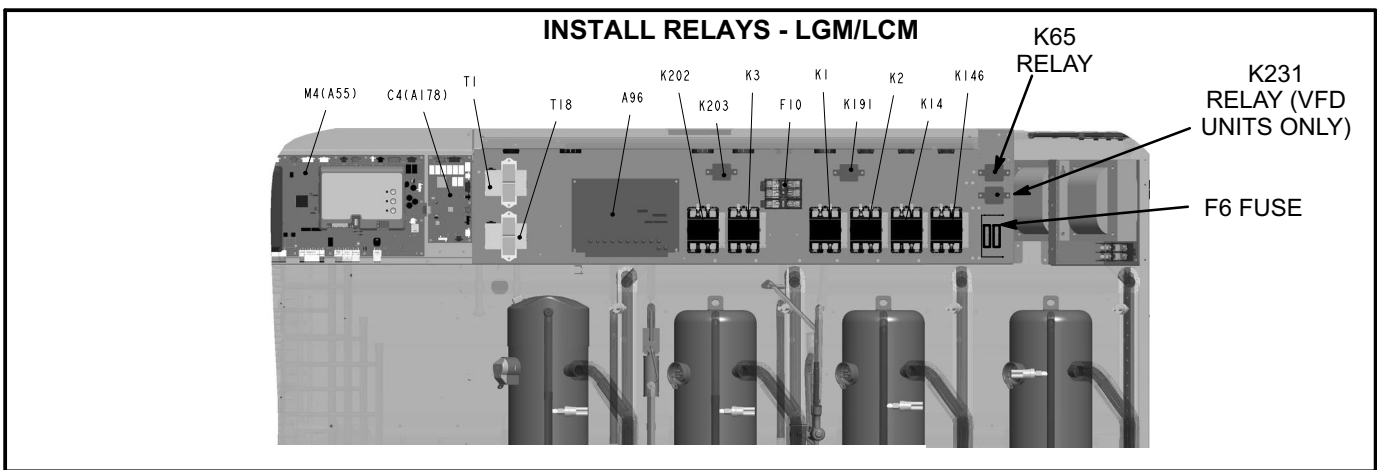

FIGURE 2

Install K65 and F6

- 1- Disconnect electrical power to unit.
- 2- Install K65 exhaust fan relay in unit control box using screws provided. On units equipped with a variable frequency drive (VFD), install K231 in addition to K65. See figure 1 or 2.
- 3- Install F6 fuse block near F10 or F58 fuse block. Insert fuses provided. See figure 1 or 2.

Harness Routing and Connections

- 1- Route wire harnesses; refer to figure shown in table 2. See *Install PEF and Strain Relief* section to install 606805 adapter harnesses (when used).
- 2- Harness wires are hot-stamped for identification. Make wiring connections as shown in figure referenced in table 3.

CAUTION
 As with any mechanical equipment, contact with sharp sheet metal edges can result in personal injury. Take care while handling this equipment and wear gloves and protective clothing.

**TABLE 2
 KIT HARNESS ROUTING**

Unit	Figure
All CAV Units (Excluding CE Units) KG/KC/KH VFD Units (CE not available)	3
All CE Units	4
LGH/LCH VFD (CE not available)	5
LGM/LCM VFD (CE not available)	6

**TABLE 3
 HARNESS CONNECTIONS**

Unit	Figure
KG/KC/KH	7
LGH/LCH CAV	8
LGH/LCH VFD - NO BYPASS	9
LGH/LCH VFD - WITH BYPASS	10
LGM/LCM VFD - WITH AND W/O BYPASS	11

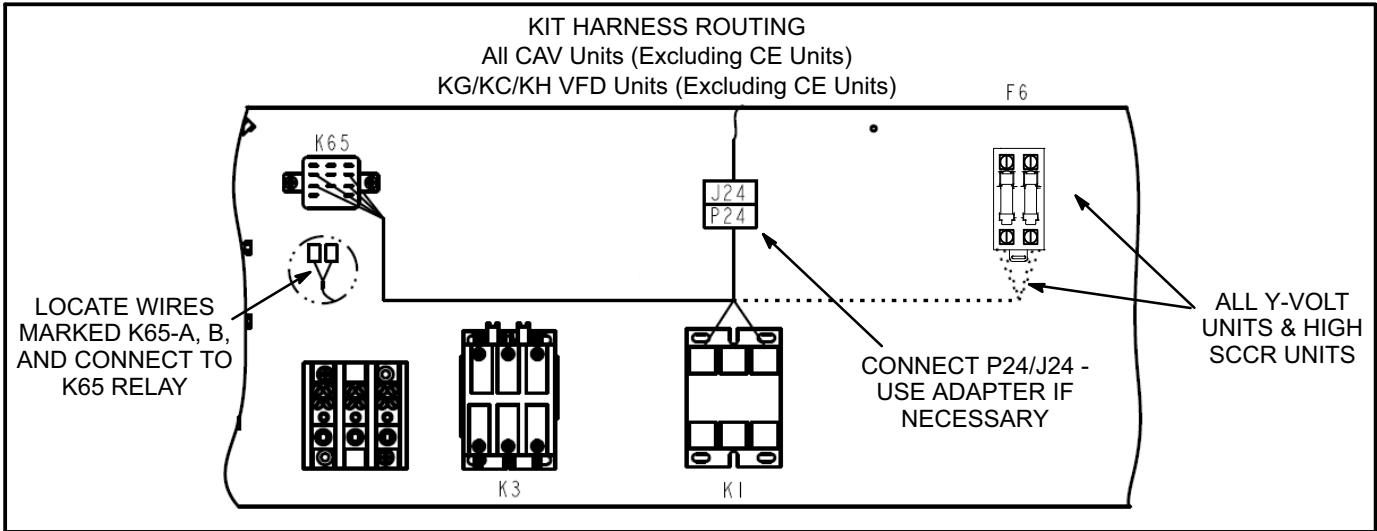

FIGURE 3

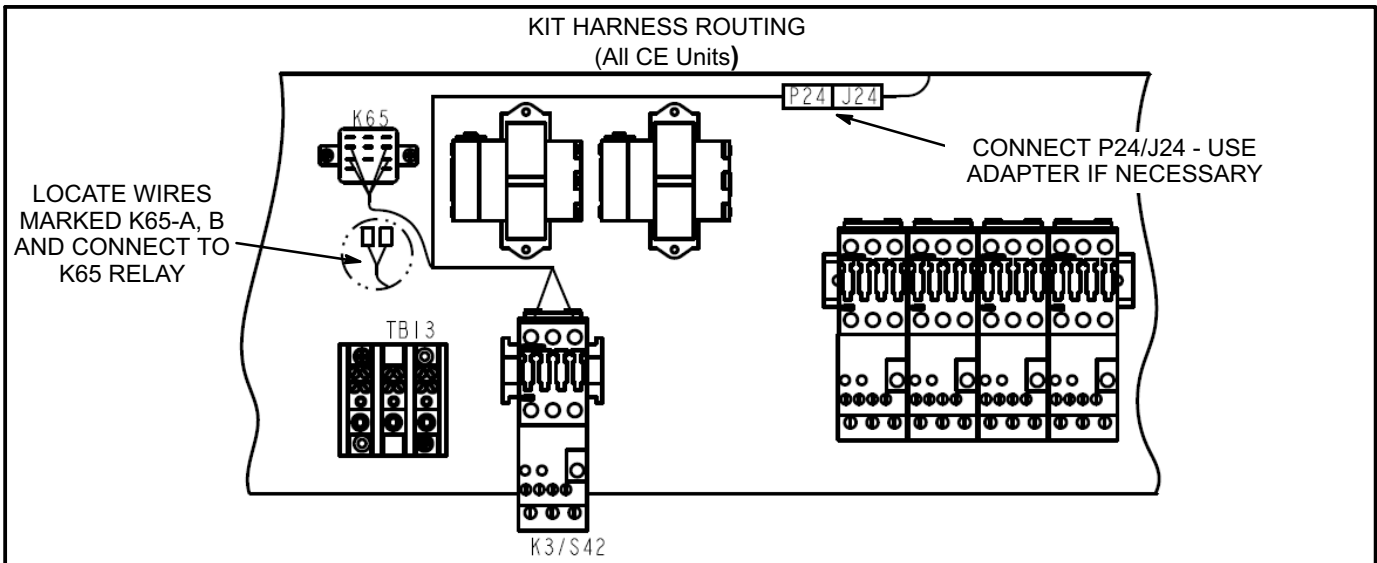

FIGURE 4

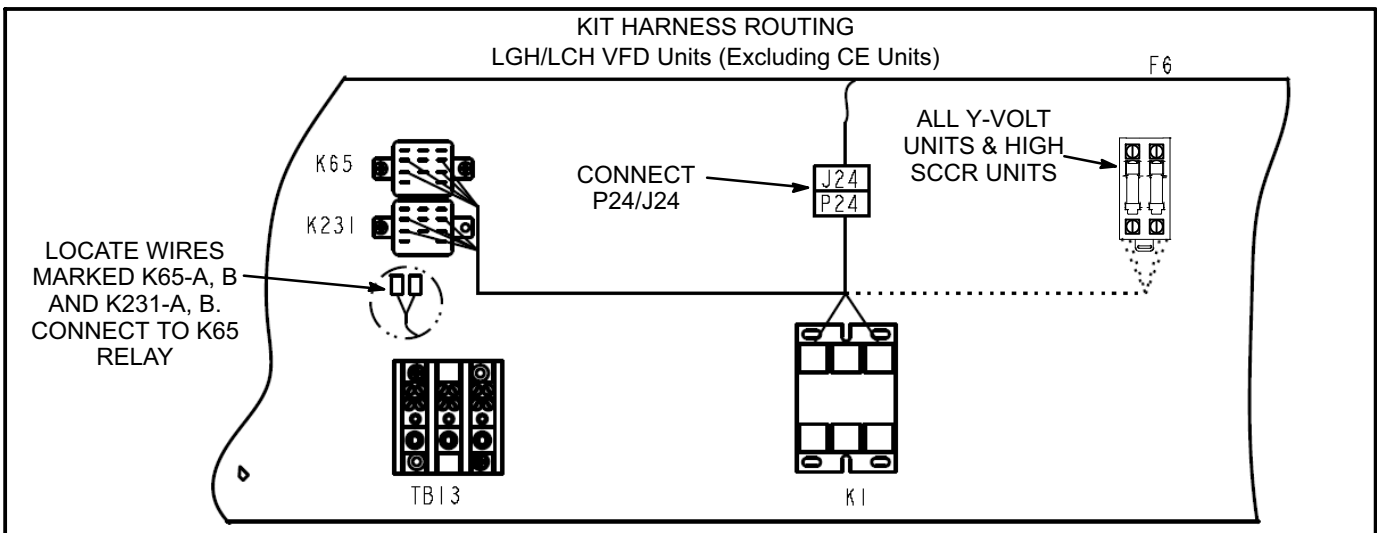

FIGURE 5

KIT HARNESS ROUTING
LGM/LCM VFD Units (Excluding CE Units)

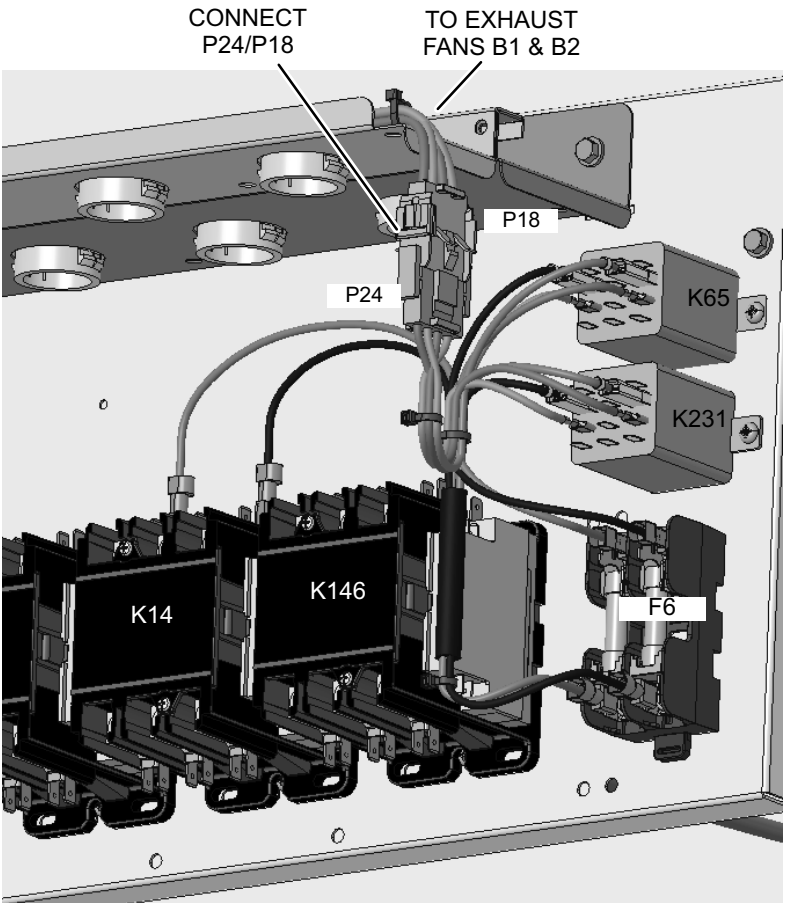

FIGURE 6

KG/KC/KH 156-300 WIRING - CAV & VFD

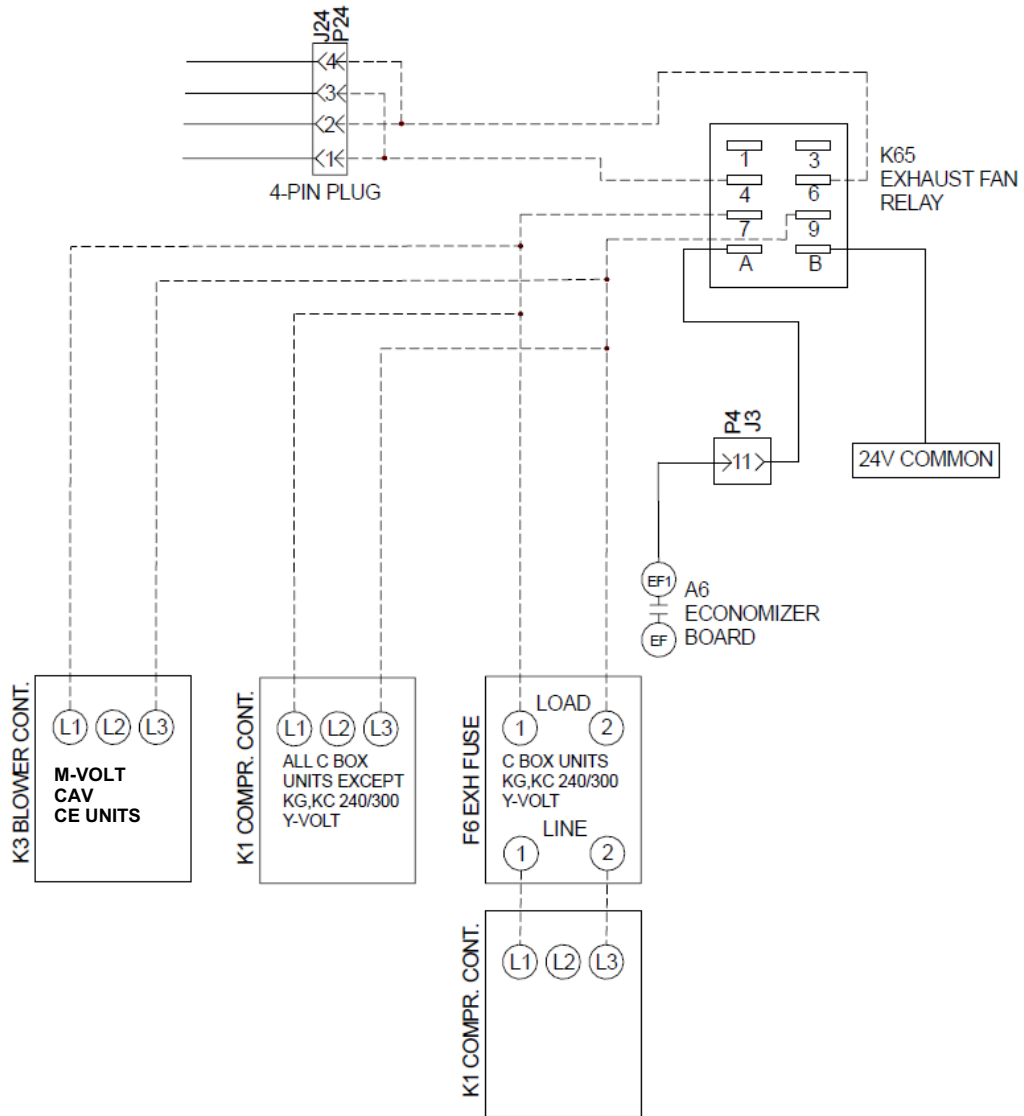

FIGURE 7

LGH/LCH 156-300 WIRING - CAV

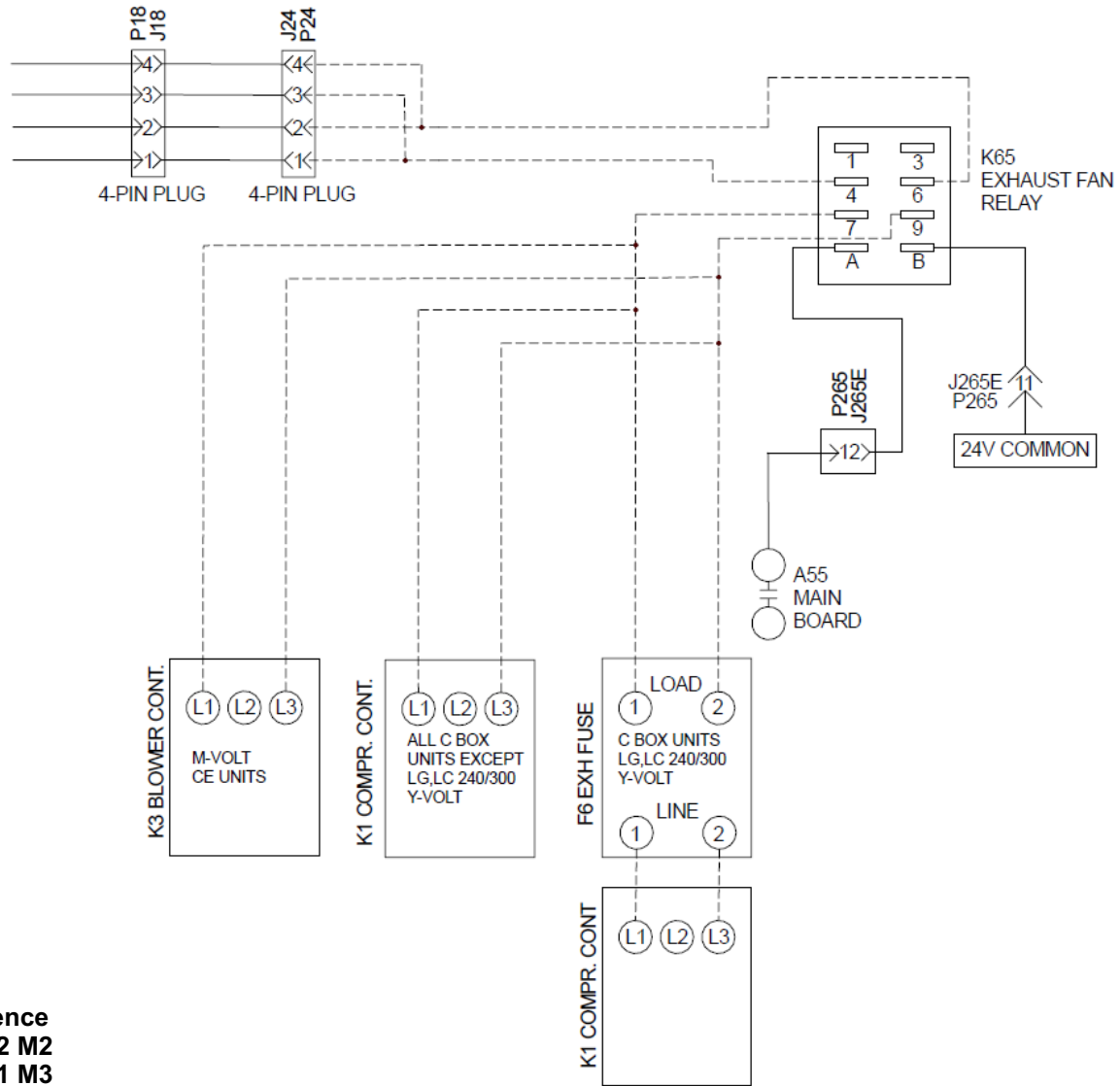
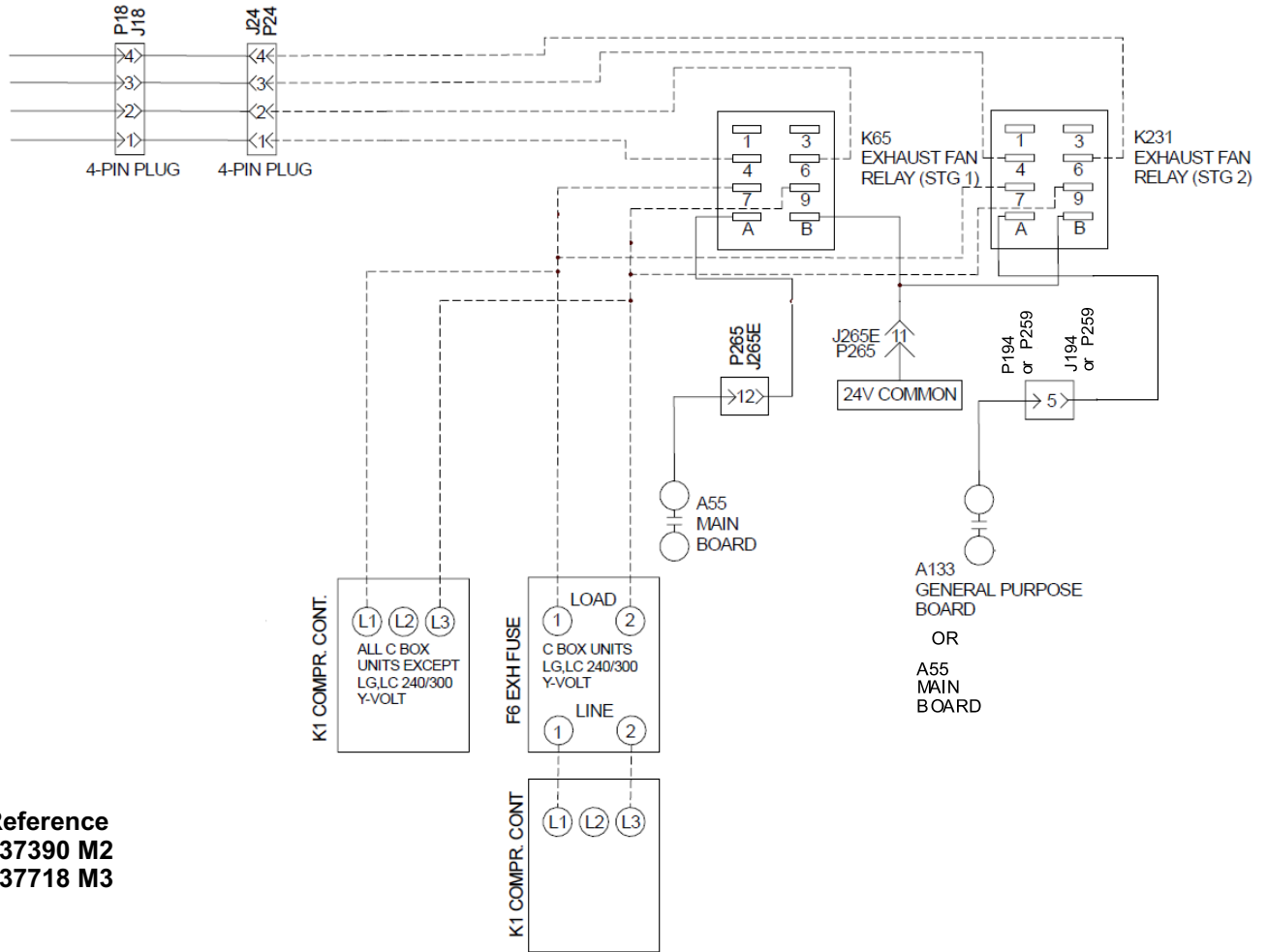

FIGURE 8

LGH/LCH 156-300 WIRING - VFD UNITS - NO BYPASS



Reference
537390 M2
537718 M3

FIGURE 9

LGH/LCH 156-300 WIRING - VFD UNITS - WITH BYPASS

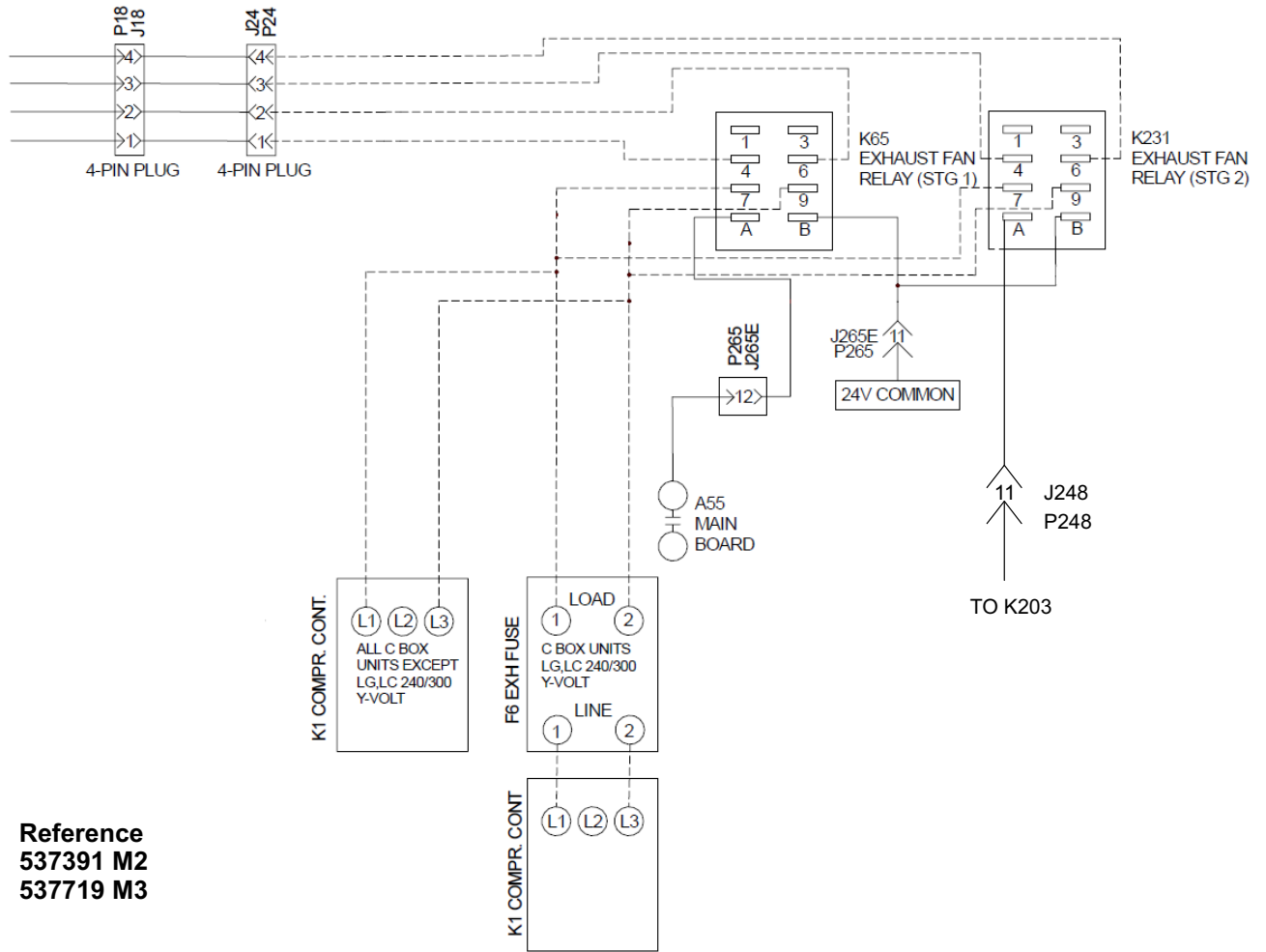

FIGURE 10

LGM/LCM 156-300 WIRING

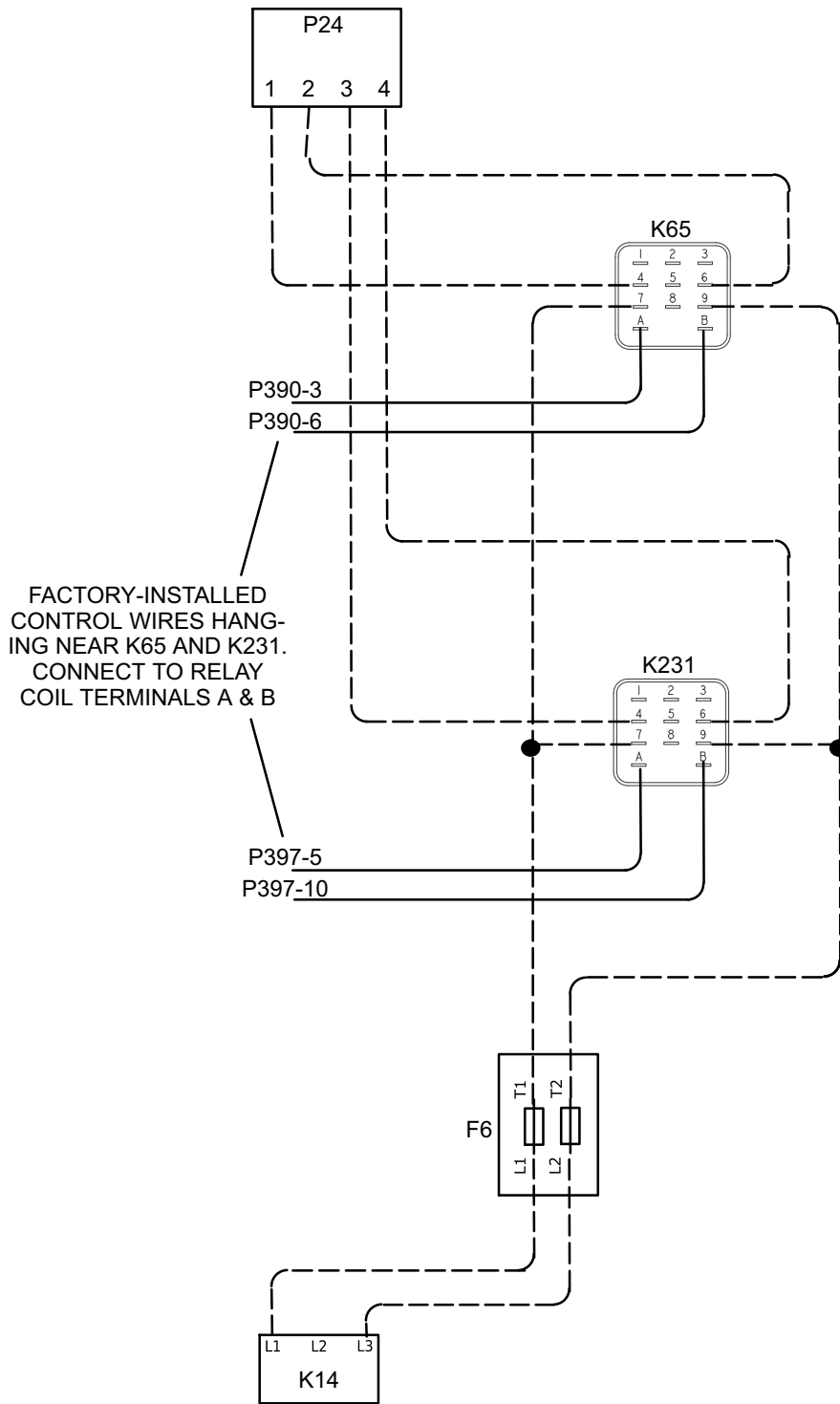

FIGURE 11

Install PEF and Rain Shield

- 1- Remove both upper and lower accessory panels from unit. Retain screws for future use. Also remove optional gravity exhaust damper if unit contains one.
- 2- Install the strain relief, bushing, and rain shield as shown in figure 12.
- 3- Apply foam insulating tape on the back of the flanged edges of the fan assembly.
- 4- Reach through fan orifice and connect power exhaust fan P18 plug to unit J18 jack. J18 is located on the left side underneath the fresh/exhaust air divider panel. See figure 13. Coil and wire tie excess wire away from moving parts.

Older Units Equipped With 3-Pin J18 and J24 -
Connect one 606805 adapter harness between J24 and P24 in the control area. Connect the other harness between J18 on the exhaust fan harness and P18 provided in the unit. See figure 14.

- 5- Lift the fan assembly into the opening and insert the top side first. Align the top of the assembly inside the flange on the division panel. Secure the bottom of the assembly to the unit with screws provided. See figure 13.
- 6- Install gravity exhaust damper according to instructions provided with damper.

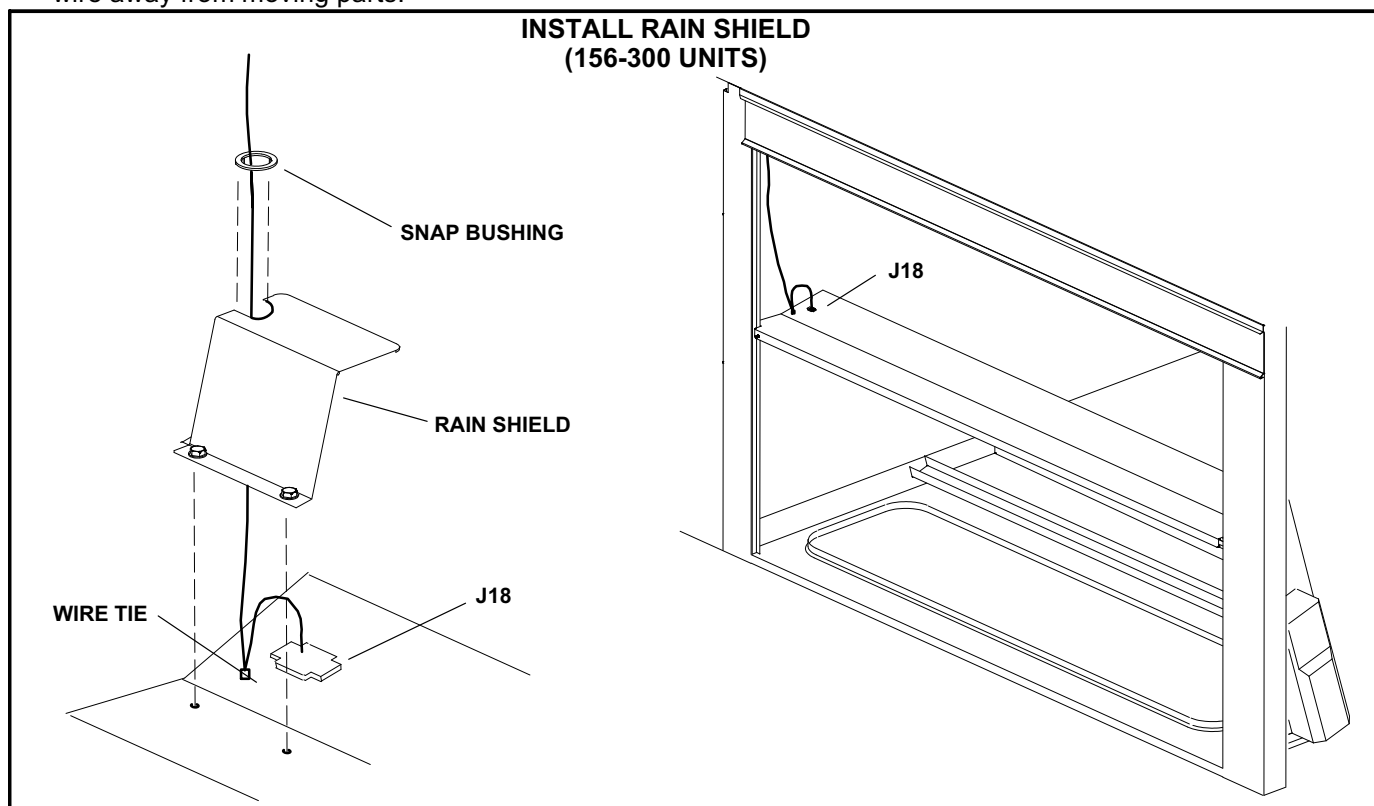

FIGURE 12

POWER EXHAUST FAN ASSEMBLY

NOTE - Apply foam insulating tape to back of flanged edges before installing exhaust fan and gravity exhaust dampers.

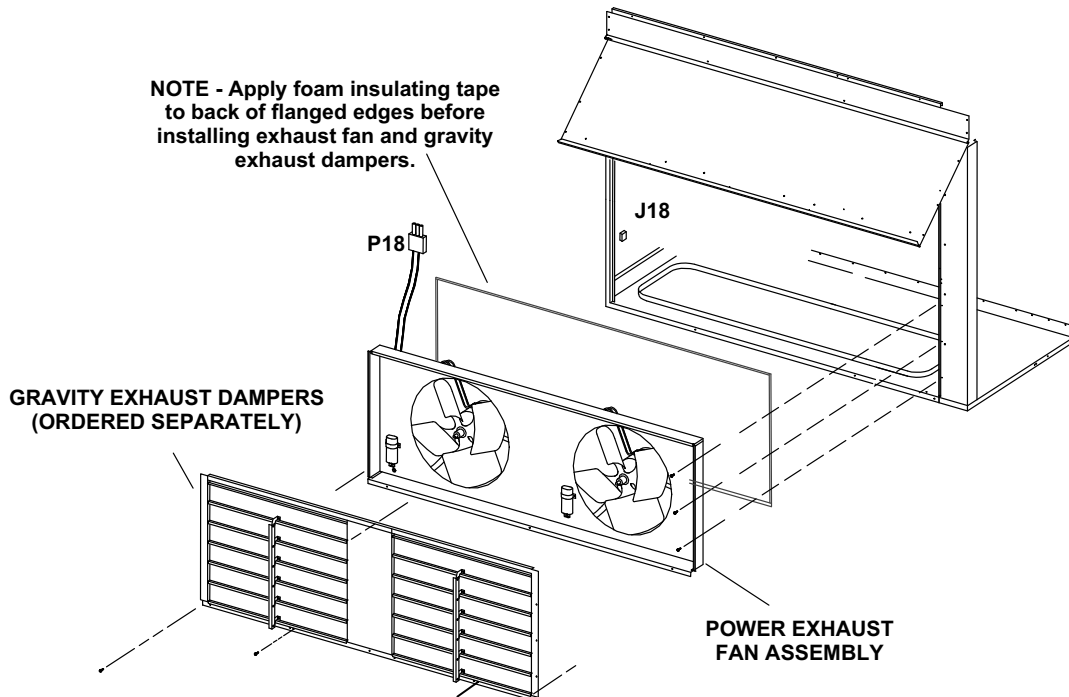

FIGURE 13

ADAPTER HARNESS - OLDER UNITS EQUIPPED WITH 3-PIN J18 AND J24

UNIT OUTDOOR AIR SECTION

CONTROL BOX

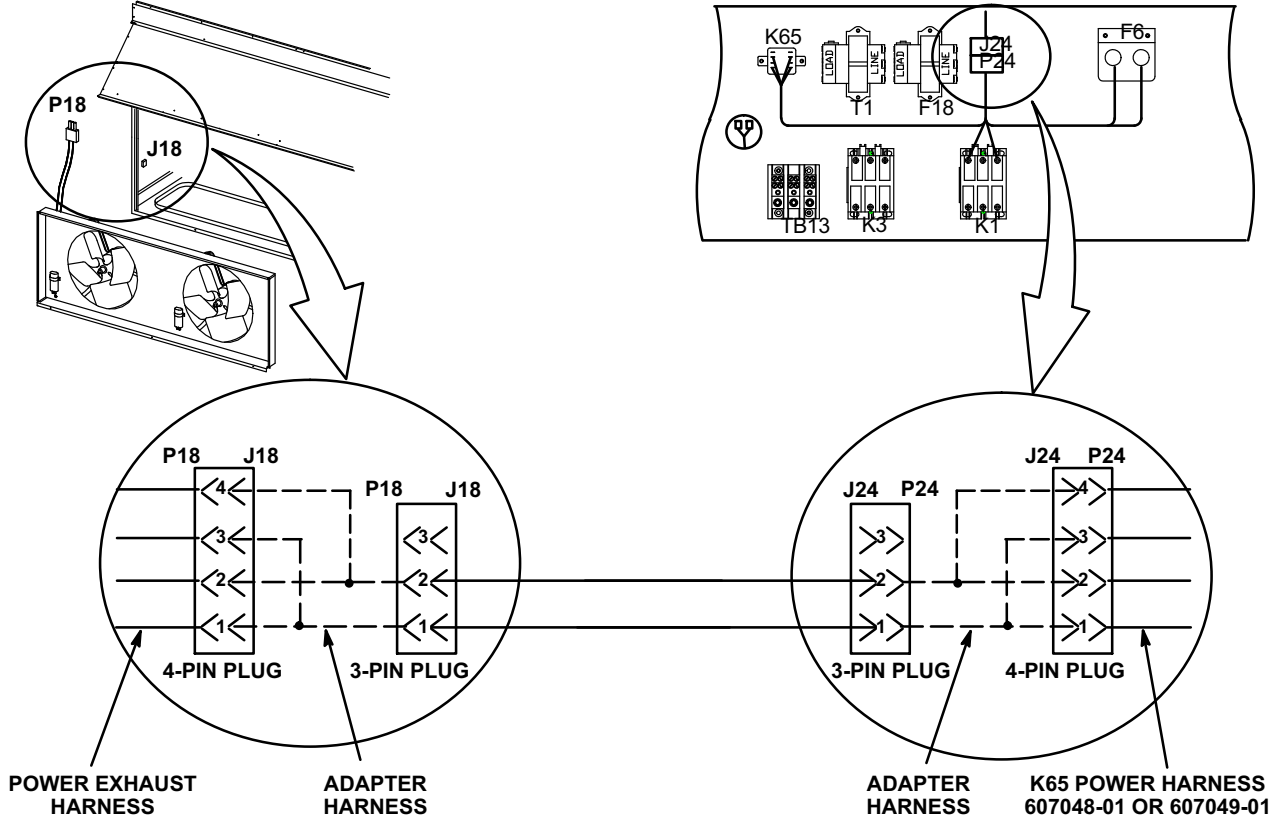

FIGURE 14

Set Unit Controller - LG/LC Units

Use the Unit Controller manual provided with each unit to enable the exhaust fan.

M2 Unit Controller

Use the following menu when installing exhaust fans in CAV units or VFD units using an ALC temperature control system:

*Settings>Install>New M2>Exhaust Stages>
1 Exhaust Stage*

Use the following menu when installing exhaust fans in VFD units (excluding units using an ALC temperature control system):

*Settings>Install>New M2>Exhaust Stages>
2 Exhaust Stages*

M3 Unit Controller

Go to SETUP / INSTALL and set Configuration ID 1, position 3 to (S = Single Stage or D = Dual Stage).

Go to SETUP / INSTALL and set Configuration ID 1, position 4 to A = Damper Position

M4 Unit Controller

Use the following menu in the mobile app to enable electric heat.

RTU MENU > SETUP > INSTALL

Select configuration I.D. 1 and change (3) Power Exhaust to D=Dual-Stage.

Operation

Power exhaust fans are energized when economizer dampers reach 50% (default).

Power Exhaust Setpoint Adjustment

LG/LC Units - Refer to the Unit Controller manual provided with each rooftop unit.

KG/KC/KH Units - Locate the A6 enthalpy control in the economizer side panel. The EXH SET potentiometer is factory-set at approximately 50% of the dial range. See figure 15. Power exhaust fans will be energized 30 seconds after dampers are 50% open. Adjust the EXH SET potentiometer higher (clockwise toward 10V) to energize fans when dampers are further open. Adjust the EXH SET potentiometer lower (counterclockwise toward 2V) to energize fans when dampers are further closed. (Thirty-second delay allows dampers to partially open before exhaust fan starts.)

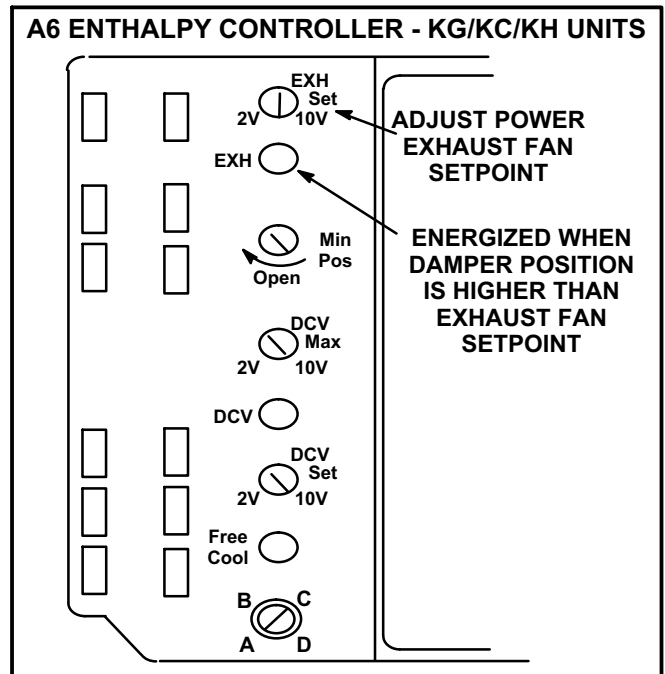

FIGURE 15