

PACKAGED UNITS KITS AND ACCESSORIES

506791-02
6/2021
Supersedes 506791-01

D4P120 & D4S SMOKE DETECTOR KITS

INSTALLATION INSTRUCTIONS FOR SMOKE DETECTOR KITS (603408-15 & 16; 22H56 & 57) USED WITH KC/KG/KH/LC/LG156-360 UNITS

Shipping and Packing List

22H56 single-sensor kit contains:

- 1- Smoke detector sensor
- 1- Smoke detector power board
- 1- Power board mounting bracket
- 1- Supply bracket
- 1- Power harness J255 (used on KC/KG/KH units only)
- 1- Jumper harness P250/J261 (used with supply air applications only)
- 2- Metal sampling tubes
- 1- Plastic exhaust tube
- 1- Magnet
- 1- Grommet
- 1- Sensor manufacturer's instructions
- 4- #8 - 32 X 1" thread -forming screws
- #10 - 32 X 3/8" thread forming screws
- 1- Insertion wire tie

22H57 dual-sensor kit contains:

- 2- Smoke detectors
- 1- Smoke detector power board assembly
- 1- Power board mounting bracket
- 1- Supply bracket
- 1- Power harness J255 (used on KC/G/KH units only)
- 2- Metal sampling tubes
- 2- Plastic exhaust tubes
- 2- Magnets
- 1- Grommet
- 1- Sensor manufacturer's instructions
- 6- #8 - 32 X 1" thread -forming screws
- #10 - 32 X 3/8" thread forming screws
- 1- Insertion wire tie

⚠ CAUTION

Before attempting to perform any service or maintenance, turn the electrical power to unit OFF at disconnect switch.

Application

LC and LG Units -- Smoke detector will send a 24Vac signal to the unit controller when smoke is sensed. The unit controller default mode will de-energize unit.

KC/KG/KH Units --Smoke detector will interrupt the 24Vac signal to the unit control circuit when smoke is sensed. Unit will be de-energized.

Kit 22H56 (603408-15) is used in either supply or return air applications. Kit 22H57 (603408-16) is used when both supply and return air smoke detectors are installed.

Installation

⚠ WARNING

Improper installation, adjustment, alteration, service or maintenance can cause property damage, personal injury or loss of life. Installation and service must be performed by a qualified installer, service agency or the gas supplier

⚠ CAUTION

Danger of sharp metallic edges. Can cause injury. Take care when servicing unit to avoid accidental contact with sharp edges.

Smoke detector sensor and power board installation

Use manufacturer's instructions provided with smoke detector to install sensor(s) and power board.

156, 180, 210, 240, 300S Units -
Install the power board on the compressor rail using the bracket provided in the kit. See figure 1. When mounting holes are not available on the compressor rail, install power board on the compressor section wall and discard the mounting bracket provided in kit.

242H, 300H, 360 Units -
Install the power board on the compressor section wall and discard the mounting bracket provided in kit. See figure 2.

Refer to figure 1 for location of power board, supply air sensor and return air sensor.



SMOKE DETECTOR COMPONENT LOCATIONS

(1560300S Unit With Economizer Shown)

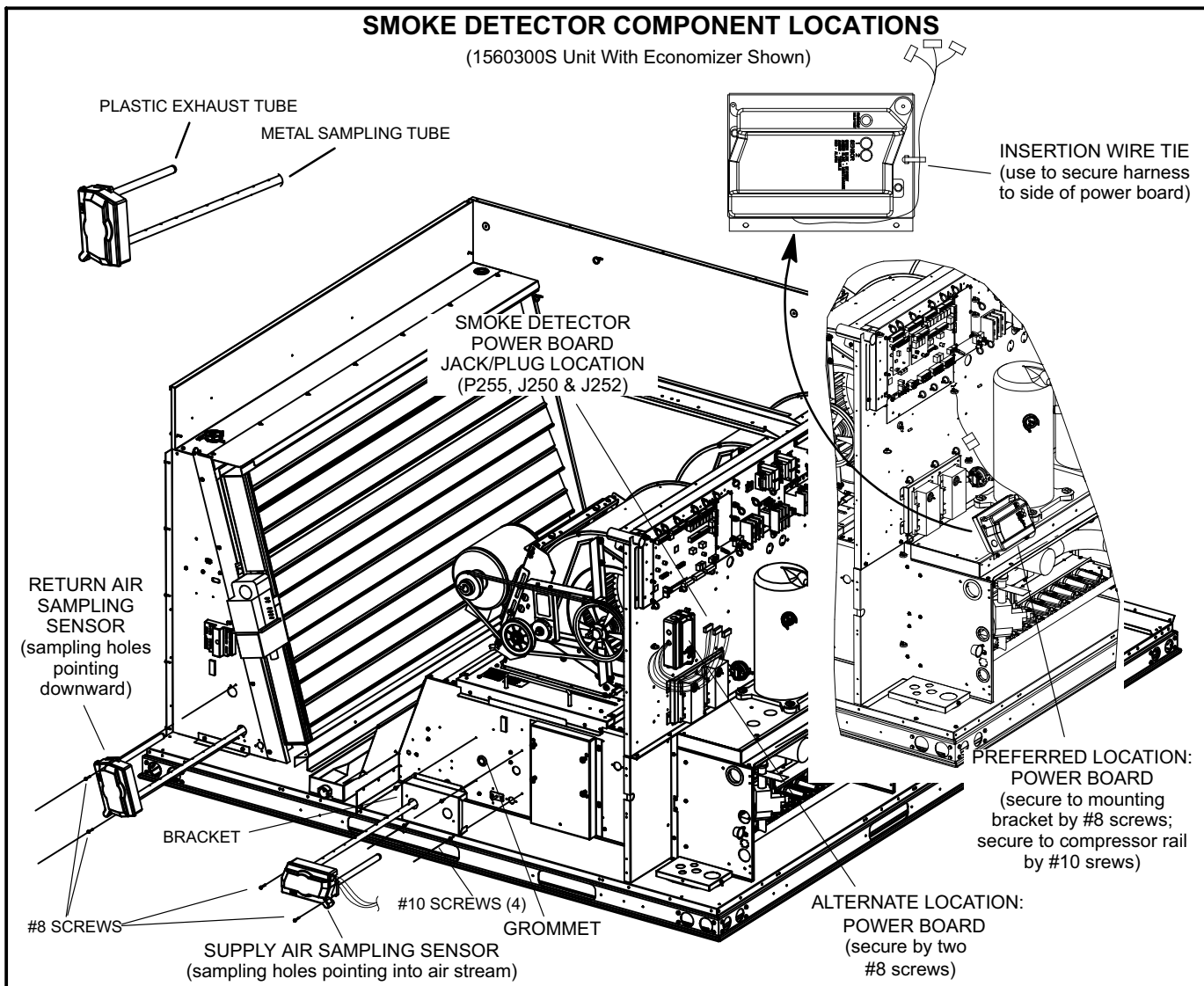

FIGURE 1

SMOKE DETECTOR POWER BOARD LOCATION

(242H, 300H, 360H Unit Shown)

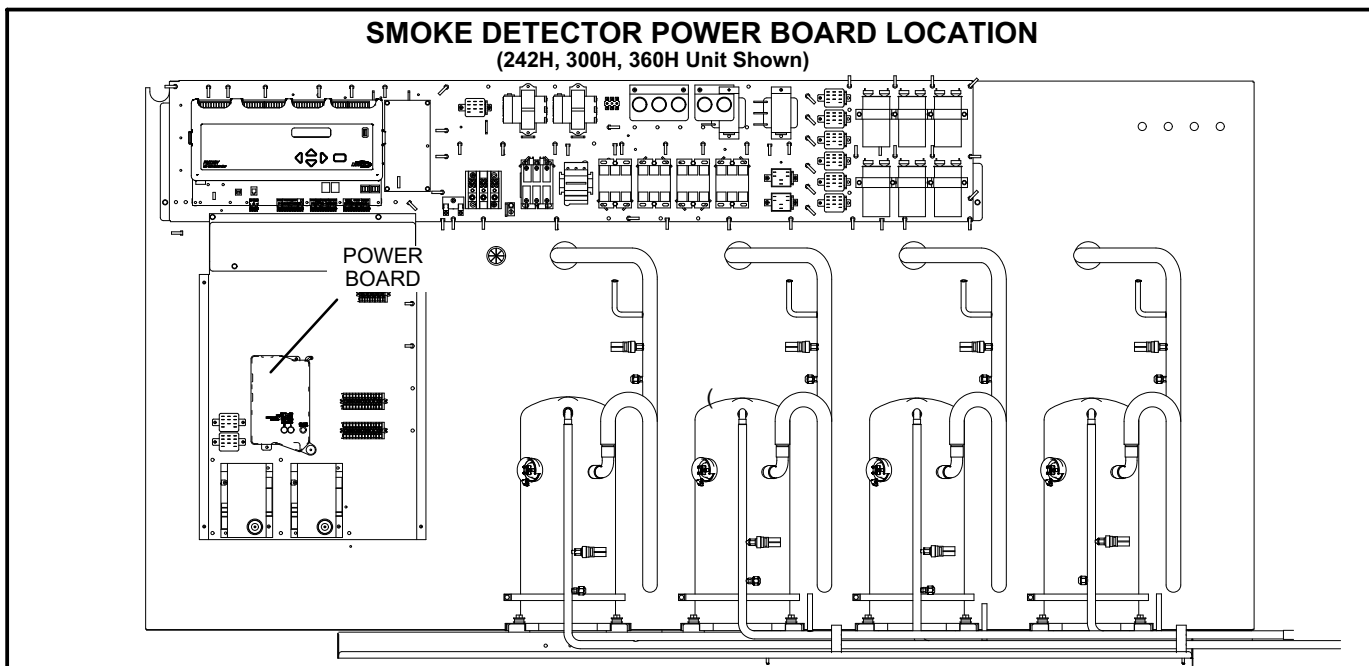

FIGURE 2

Sampling tube installation

- 1- Select the appropriate sampling tube.
Return air sensor -- 36"
Supply air sensor -- 30"

- 2- Slide metal sampling tube and plastic exhaust tube onto the back side of the sensor as shown in figure 3.
- 3- Orient sampling tube so that holes point toward the air stream.

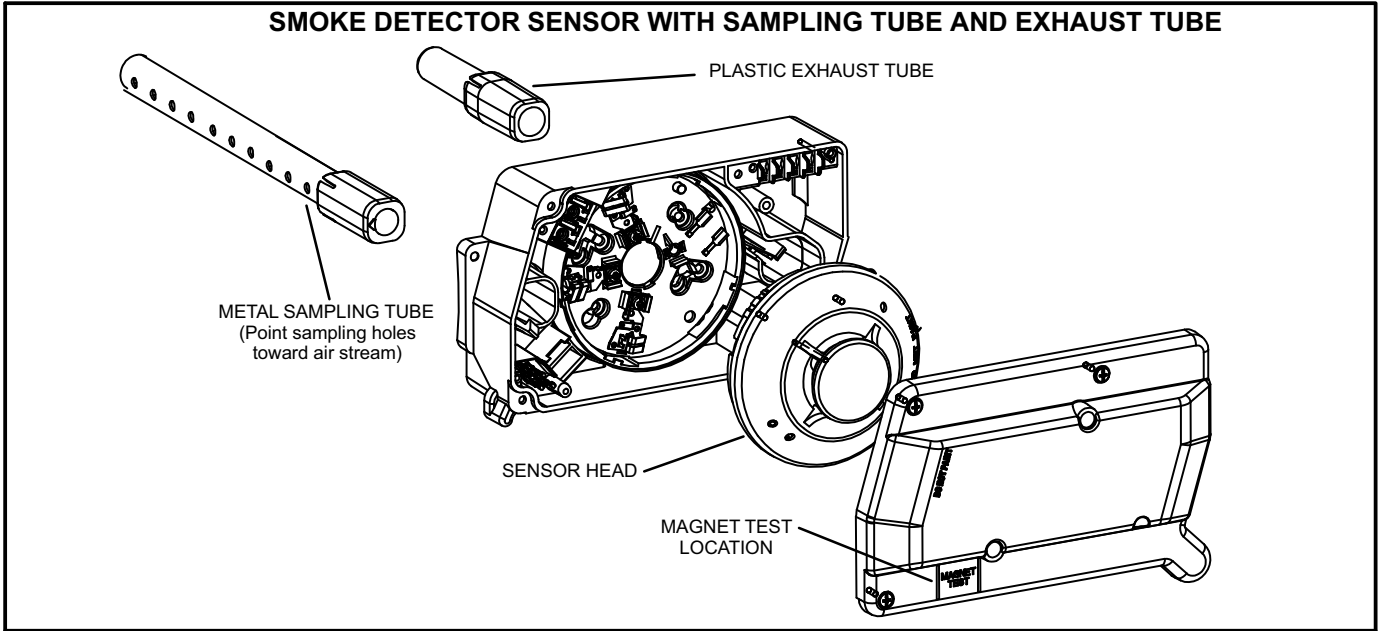

FIGURE 3

Wiring - KG/KC/KH Units

- 1- Locate and disconnect wires labeled SM-1 and SM-4 in control area. See figure 4.
- 2- Connect wires labeled SMOKE-1 and SMOKE-4 from kit power harness to wires labeled SM-1 and SM-4 in unit. Connect wire labeled GND from the kit harness to the ground tab in unit. Position J255 from

power harness near the power board jack/plugs in the compressor section. Use markings on wires to identify jack/plugs.

- 3- Make jack/plug connections as shown in figure 5 when installing return air smoke detector only, figure 6 when installing supply air smoke detector only and figure 7 when installing both supply and return air smoke detectors.

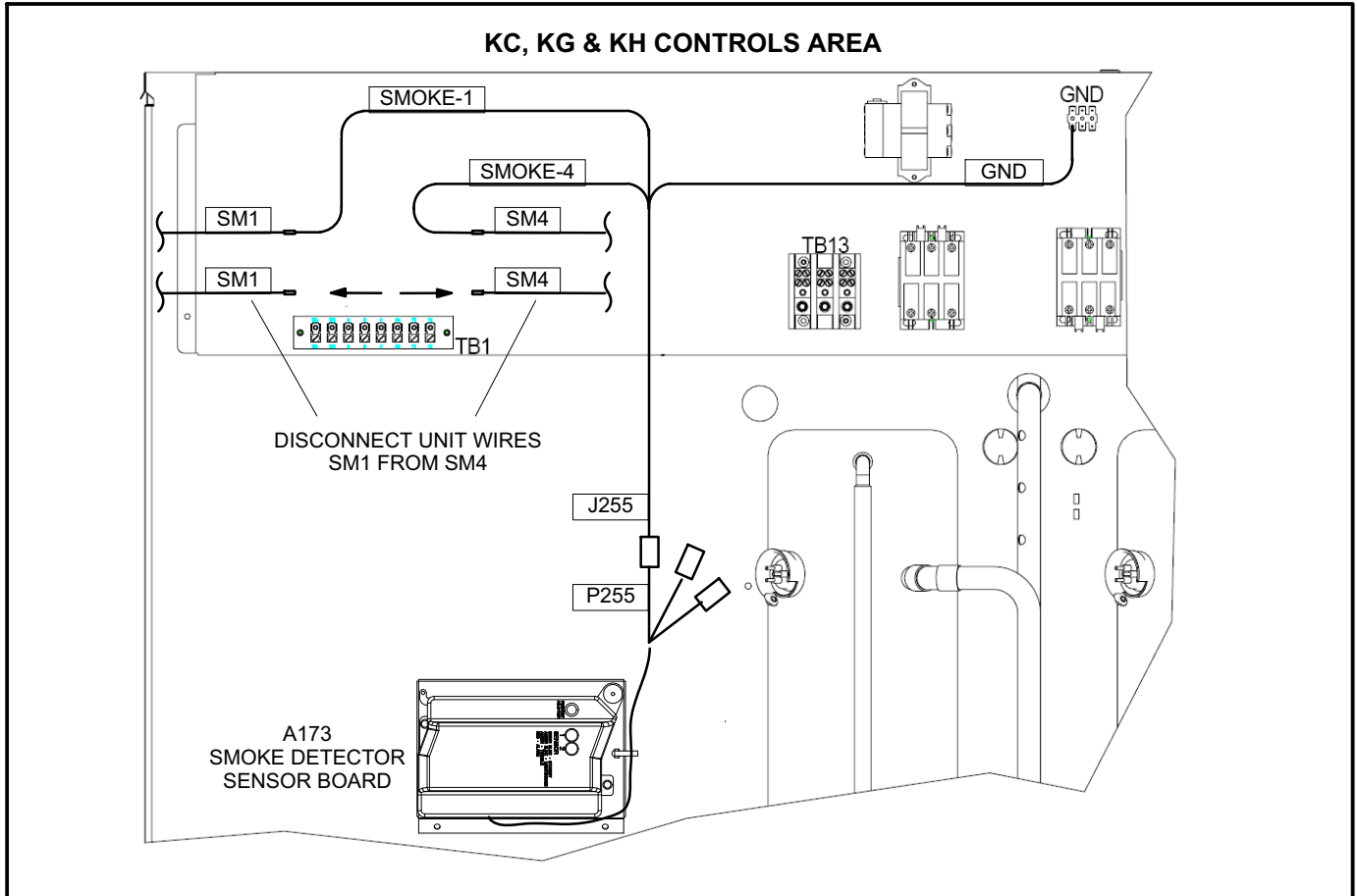

FIGURE 4

Wiring - KG/KC/KH Units (continued)

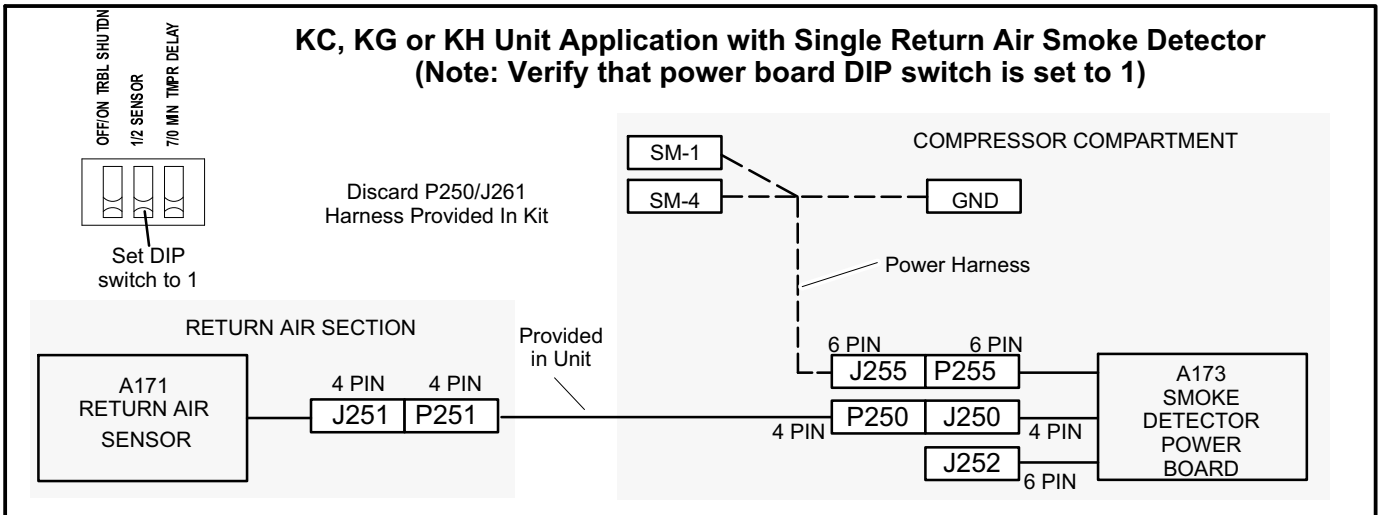

FIGURE 5

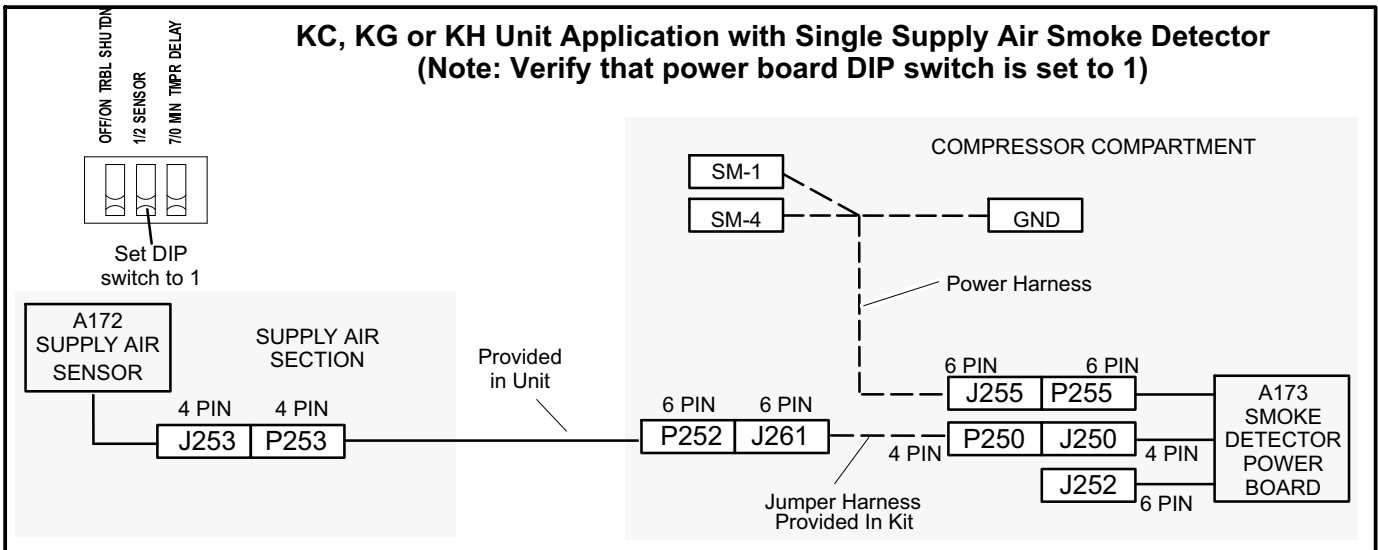

FIGURE 6

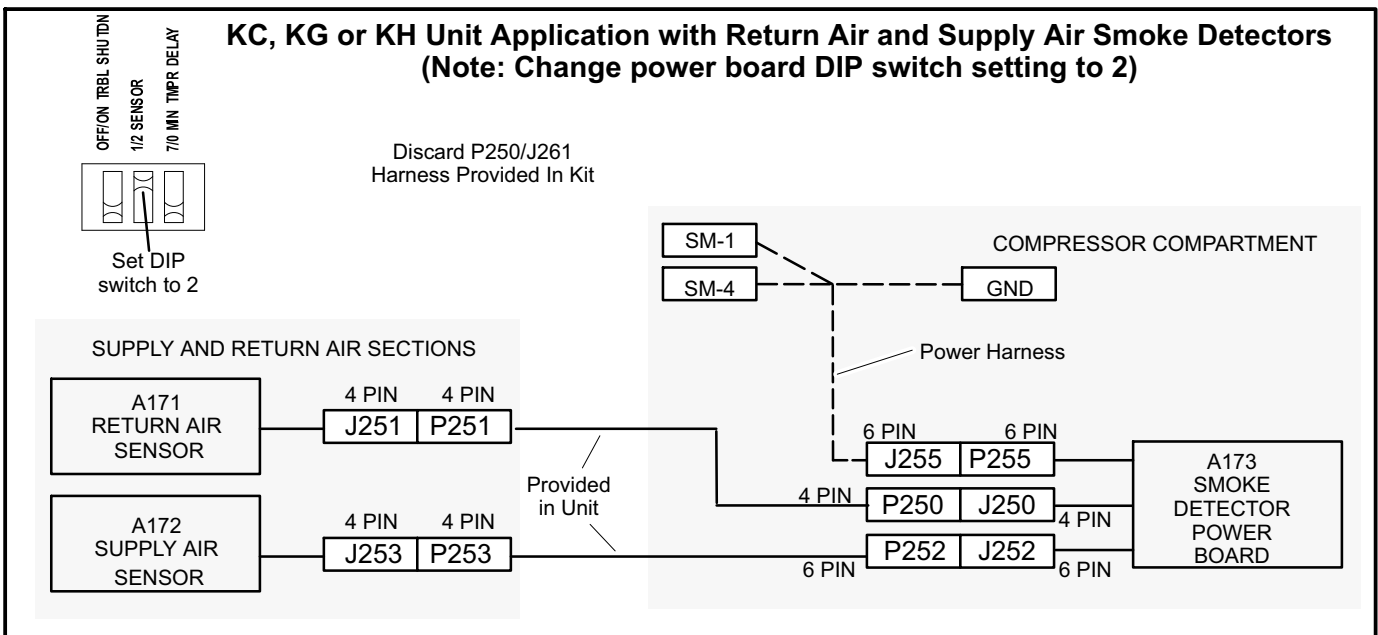

FIGURE 7

Wiring - LG/LC Units

Make jack/plug connections as shown in figure 8 when installing return air smoke detector only, figure 9 when

installing supply air smoke detector only and figure 10 when installing both supply and return air smoke detectors. Plugs are located in the unit near the location of the sensor(s) and power board. See figure 1.

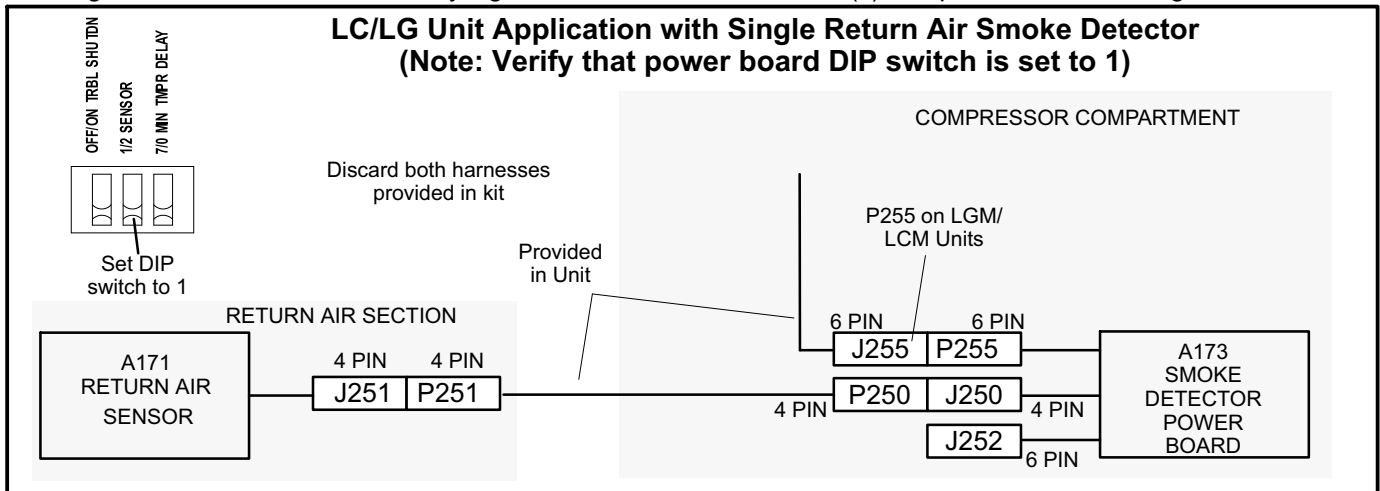

FIGURE 8

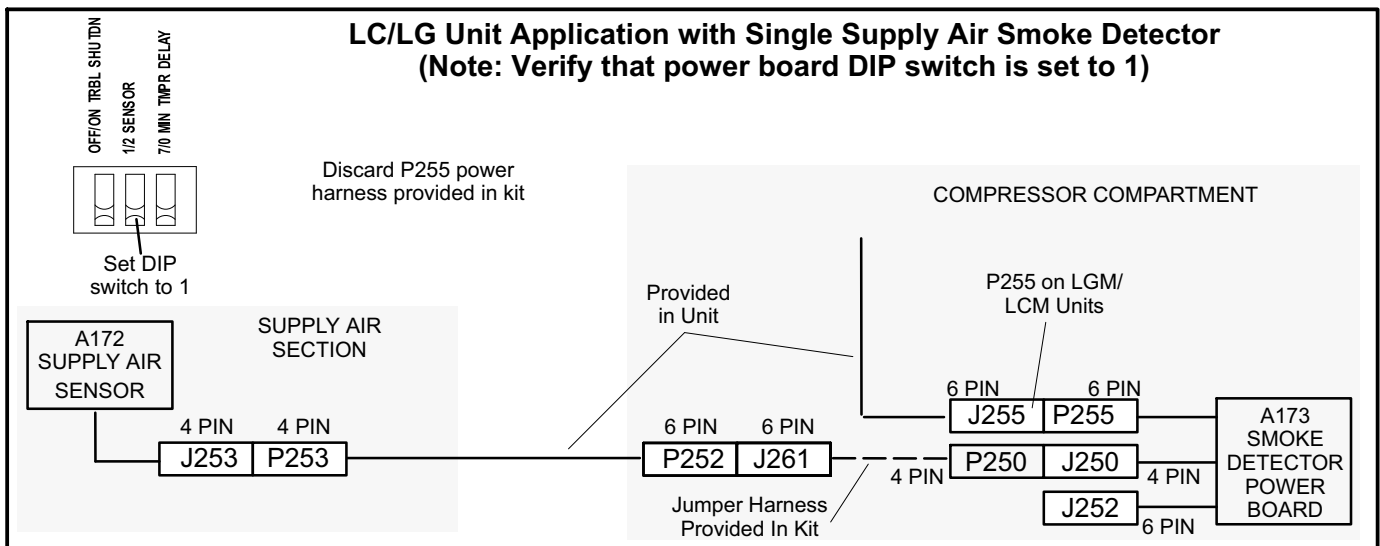

FIGURE 9

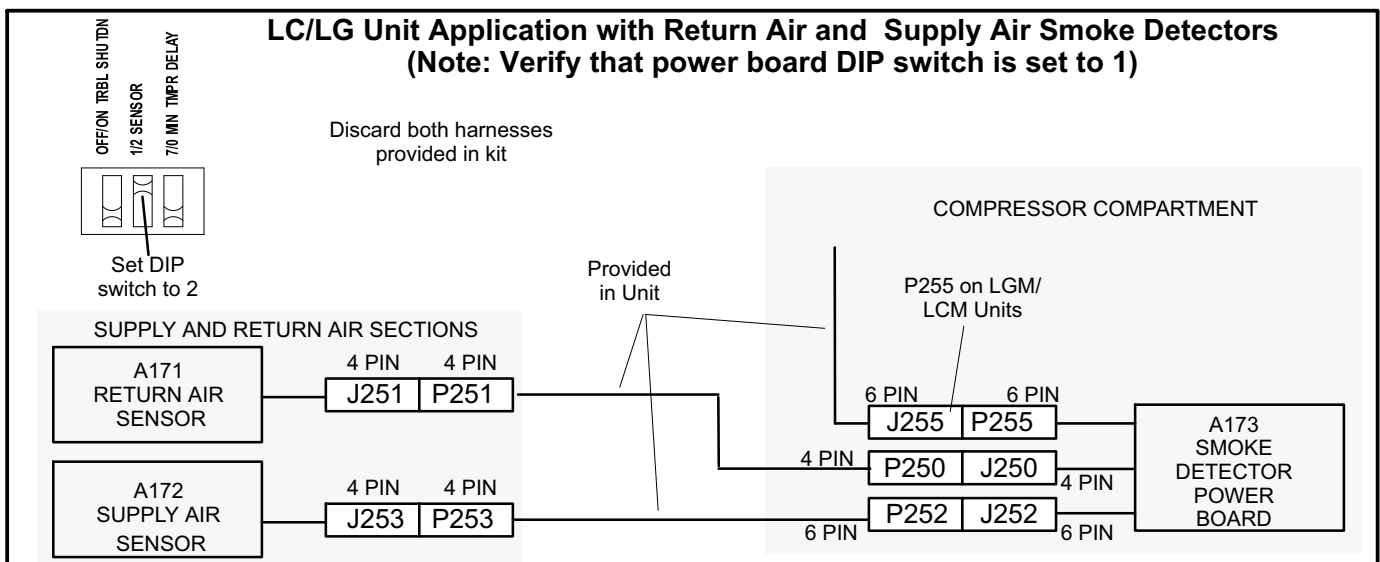

FIGURE 10

Test Magnets

A test magnet is provided in a bag assembly with each sensor. Remove the magnet from the bag assembly and place it on a metal surface near the sensor. The magnet is used during test procedures.

Maintenance and Test Procedure Instructions

The sensor manufacturer's instructions, which are provided with each sensor, outline information on maintenance and test procedures. Place these instructions in the literature pouch for future reference.