

**3" CONCENTRIC
TERMINATION KIT**

INSTALLATION INSTRUCTIONS FOR 3" CONCENTRIC TERMINATION KIT (60L46)

Shipping and Packing List

Package 1 of 1 contains:

- 1 - Rain cap (3")
- 1 - 4" diameter SDR-26 pipe (37-1/8" in length)
- 1 - 2-1/2" diameter SDR-26 pipe (24" in length)
- 1 - 3" concentric fitting

Application

Concentric termination kit (60L46) isolates intake and exhaust lines as they exit the structure.

NOTE - Concentric kit 60L46 does not require an accelerator.

Requirements

All pipe, fittings, primer and solvent cement must conform with American National Standard Institute and the American Society for Testing and Materials (ANSI/ASTM) standards. The solvent shall be free flowing and contain no lumps, undissolved particles or any foreign matter that adversely affects the joint strength or chemical resistance of the cement. The cement shall show no gelation, stratification, or separation that cannot be removed by stirring. Refer to table 1 for approved piping and fitting materials.

**TABLE 1
PIPING AND FITTING SPECIFICATIONS**

PIPE & FITTING MATERIAL	ASTM SPECIFICATION
Schedule 40 PVC (Pipe)	D1785
Schedule 40 PVC (Cellular Core Pipe)	F891
Schedule 40 PVC (Fittings)	D2466
SDR-21PVC (Pipe)	D2241
SDR-26 PVC (Pipe)	D2241
Schedule 40 ABS (Pipe)	D1527
Schedule 40 ABS (Fittings)	D2468
ABS-DWV (Drain Waste & Vent) (Pipe & Fittings)	D2661
PVC-DWV (Drain Waste & Vent) (Pipe & Fittings)	D2665

⚠ CAUTION

Solvent cements for plastic pipe are flammable liquids and should be kept away from all sources of ignition. Do not use excessive amounts of solvent cement when making joints. Good ventilation should be maintained to reduce fire hazard and to minimize breathing of solvent vapors. Avoid contact of cement with skin and eyes.

Primers and solvents must meet ASTM specifications. PVC primer is specified in ASTM F 656. Use PVC solvent cement as specified in ASTM D 2564 and ABS solvent cement as specified in ASTM D 2235. Low temperature solvent cement is recommended. Metal or plastic strapping may be used for vent pipe hangers.

When making ABS joints, pieces can be prepared with a cleaner. When joining ABS to PVC materials, use PVC solvent cement. Refer to this procedure as specified in ASTM D3138.

Joint Cementing Procedure

All cementing of joints should be done according to the specifications outlined in ASTM D 2855.

⚠ WARNING

DANGER OF EXPLOSION! Fumes from PVC glue may ignite during system check. Disconnect wire from pressure switch terminal before 115V power is applied. Reconnect wire after two minutes of combustion air blower operation.

- 1 - Measure and cut vent pipe to desired length.
- 2 - Debur and chamfer end of pipe, removing any ridges or rough edges. If end is not chamfered, edge of pipe may remove cement from fitting socket and result in a leaking joint.
- 3 - Clean and dry surfaces to be joined.
- 4 - Test fit joint and mark depth of fitting on outside of pipe.
- 5 - Uniformly apply liberal coat of PVC primer for PVC or ABS cleaner for ABS to inside socket surface of fitting and male end of pipe to depth of fitting socket.

- 6 - Promptly apply solvent cement to end of pipe and inside socket surface of fitting. Cement should be applied lightly but uniformly to inside of socket. Take care to keep excess cement out of socket. Apply second coat to end of pipe.

NOTE - Time is critical at this stage. Do not allow primer to dry before applying cement.

- 7 - Immediately after applying last coat of cement to pipe, and while both inside socket surface and end of pipe are wet with cement, forcefully insert end of pipe into socket until it bottoms out. Turn pipe 1/4 turn during assembly (but not after pipe is fully inserted) to distribute cement evenly.

NOTE - Assembly should be completed within 20 seconds after last application of cement. Hammer blows should not be used when inserting pipe.

- 8 - After assembly, wipe excess cement from pipe at end of fitting socket. A properly made joint will show a bead around its entire perimeter. Any gaps may indicate a defective assembly due to insufficient solvent.

- 9 - Handle joints carefully until completely set.

Assembly and Installation

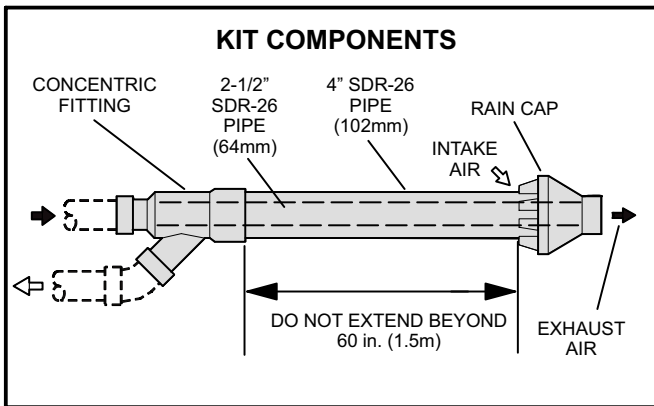

FIGURE 1

Concentric Termination -- Rooftop Application

- 1 - Determine the best area for the termination to exit the roof.
- 2 - Cut one hole approximately 5 inches (127mm) in diameter in roof.
- 3 - Use proper joint cementing procedure to join concentric fitting and 4-inch (102mm) diameter pipe provided in kit. Cement rain cap to 2-1/2 inch (64mm) diameter pipe provided. See figure 1 for component identification.

NOTE - The 2-1/2 inch (64mm) diameter pipe may be secured to the rain cap with a stainless steel screw rather than cement to provide access for future cleaning. See figure 2.

⚠ WARNING

A clearance hole must be drilled in the rain cap and a pilot hole must be drilled in the 2-1/2 inch (64mm) vent pipe if the two are going to be joined using a screw. See figure 2. If these holes are not drilled, the PVC components may crack when the screw is inserted. Failure to follow this procedure may cause recirculation of combustion products which could result in personal injury or death.

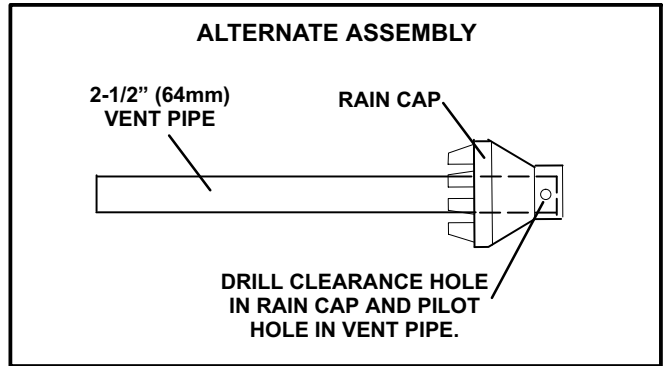

FIGURE 2

⚠ WARNING

DO NOT operate the furnace unless the rain cap has been installed. Products of combustion may be recirculated. In addition, water may collect in the 4-inch (102mm) inlet air pipe and flow into the burner enclosure. Failure to follow this warning could result in product damage or improper operation, personal injury or death.

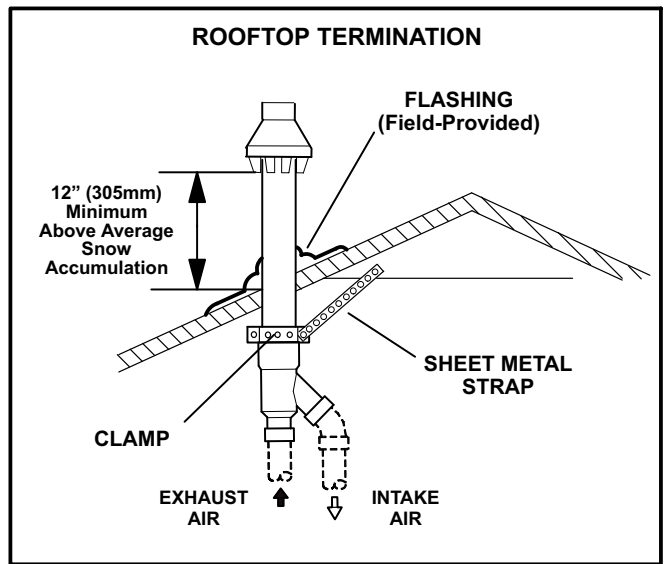

FIGURE 3

- 4 - Run 4-inch (102mm) pipe through roof opening. Use a sheet metal strap to secure the termination to the roofing joist as shown in figure 3.
- NOTE - Weight of termination must be supported by the clamp and sheet metal strap.*

⚠ CAUTION

Concentric vent termination air inlet must extend a minimum of 12 inches (305mm) above the average snow accumulation. If necessary, replace kit-supplied SDR-26 PVC (D2241) pipes with longer pipes of the same diameter. Do not extend length beyond dimension given in figure 1. **DO NOT** use couplings to extend length of pipes. Airflow will be restricted and unit operation may be interrupted by the pressure switch.

- 5 - Slide field-provided flashing over pipe and secure flashing to roof as shown in figure 3. Seal around flashing to make sure it is weather-tight.
- 6 - Apply solvent cement to end of 2-1/2 inch (64mm) diameter pipe and insert pipe (with rain cap attached) into 4-inch (102mm) pipe. Make sure that 2-1/2 inch (64mm) pipe is properly seated in concentric fitting.
- 7 - Connect intake and exhaust lines to termination assembly.
NOTE - Exhaust line must be insulated when run through unconditioned spaces.
- 8 - Suspend furnace vent pipe with hangers to support vent termination. See figure 4.
- 9 - Continue with installation and start-up procedures in unit installation instructions.

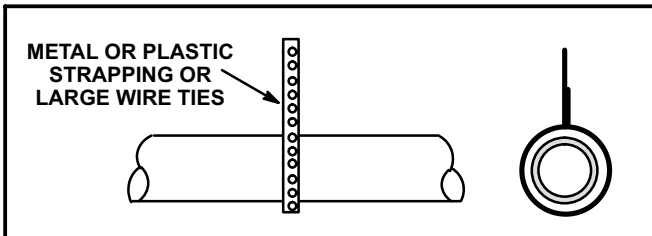

FIGURE 4

Concentric Termination -- Sidewall Application

- 1 - Determine the best area for the vent to exit the wall.
- 2 - Cut one hole approximately 5 inches (102mm) in diameter in outer wall.
- 3 - Use proper joint cementing procedure to join concentric fitting and 4-inch (102mm) diameter pipe provided in kit. Cement rain cap to 2-1/2 inch (64mm) diameter pipe provided. See figure 1 for component identification.

NOTE - The 2-1/2 inch (64mm) diameter pipe may be secured to the rain cap with a stainless steel screw rather than cement to provide access for future cleaning. See figure 2.

⚠ WARNING

A clearance hole must be drilled in the rain cap and a pilot hole must be drilled in the 2-1/2 inch (64mm) vent pipe if the two are going to be joined using a screw. See figure 2. If these holes are not drilled, the PVC components may crack when the screw is inserted. Failure to follow this procedure may cause recirculation of combustion products which could result in personal injury or death.

⚠ WARNING

DO NOT operate the furnace unless the rain cap has been installed. Products of combustion may be recirculated. Failure to follow this warning could result in product damage or improper operation, personal injury or death.

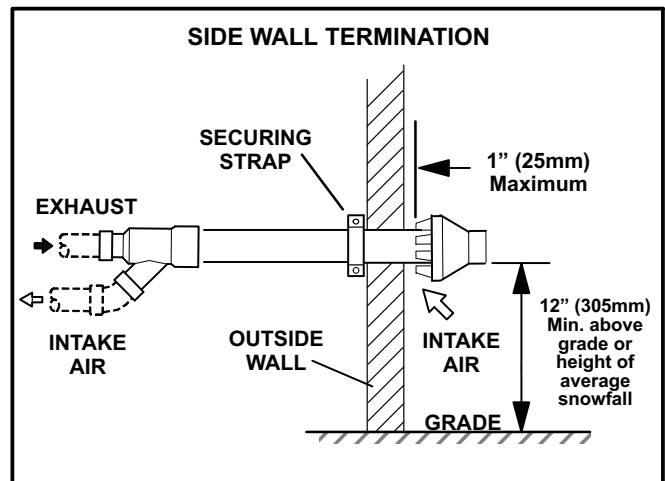

FIGURE 5

- 4 - Run 4-inch (102mm) pipe through the wall opening. Use a sheet metal strap to secure the termination to the structure as shown in figure 5.
NOTE - Weight of termination must be supported by the clamp and sheet metal strap.

⚠ IMPORTANT

Concentric vent termination must extend a minimum of 12 inches (305mm) above grade or above the height of average snow accumulation.

⚠ IMPORTANT

If the termination assembly must be lengthened to accommodate thickness of the side wall, replace kit-supplied SDR-26 PVC (D2241) pipes with longer pipes of the same diameter. Do not extend length beyond dimension given in figure 1. DO NOT use couplings to extend length of pipes. Airflow will be restricted and unit operation may be interrupted by the pressure switch.

5 - Apply solvent cement to end of 2-1/2 inch (64mm)

diameter pipe and insert pipe (with rain cap attached) into 4-inch (102mm) pipe. Make sure that 2-1/2 inch (64mm) pipe is properly seated in concentric fitting.

6 - Connect intake and exhaust lines to termination assembly.

NOTE - Exhaust line must be insulated when run through unconditioned spaces.

7 - Suspend furnace vent pipe with hangers to support vent termination. See figure 4.

8 - Continue with installation and start-up procedures in unit installation instructions.