

INSTALLATION INSTRUCTIONS FOR REPLACEMENT HEAT EXCHANGER KITS (75W25 - 75W28 & 86W40) FOR USE WITH SINGLE-STAGE AND TWO-STAGE HIGH EFFICIENCY UPFLOW/HORIZONTAL GAS FURNACES

⚠ WARNING

Improper installation, adjustment, alteration, service or maintenance can cause property damage, personal injury or loss of life. Installation and service must be performed by a licensed professional installer (or equivalent), service agency or the gas supplier.

⚠ WARNING

Disconnect power before servicing unit.

Shipping & Packing List

Package 1 of 1 contains the following:

- 1 - Heat exchanger assembly

Application

See table 1 and 2 for unit capacity and corresponding replacement kits.

**Table 1
 Single-Stage Furnace Capacity and Replacement Kit Numbers**

Unit Capacity	Replacement Kit No.	Replacement Catalog No.
070	605996-18	75W25
090	605996-19	75W26
110	605996-20	75W27
135	605996-21	75W28

**Table 2
 Two-Stage Capacity and Replacement Kit Numbers**

Unit Capacity	Replacement Kit No.	Replacement Catalog No.
070	605996-18	75W25
090	605996-42	86W40
110	605996-20	75W27
135	605996-21	75W28

Installation

Refer to figure 1 as you disassemble the the unit. Place papers or protective covering in front of the furnace before removing the heat exchanger assembly.

- 1 - Turn off electrical and gas supplies to the furnace.
- 2 - Remove the furnace access panels.
- 3 - Disconnect the 2 wires from the gas valve.
- 4 - Remove gas supply line connected to gas valve. Remove the burner box cover (if equipped) and remove gas valve/manifold assembly.
- 5 - Remove sensor wire from sensor. Disconnect 2-pin plug from the ignitor.
- 6 - Disconnect wires from flame roll-out switches.
- 7 - Disconnect combustion air intake pipe. It may be necessary to cut the existing pipe to remove burner box assembly.
- 8 - Remove four burner box screws at the vestibule panel and remove burner box. Set burner box assembly aside.
NOTE - If necessary, clean burners at this time. Follow procedures outlined in Burner Cleaning section.
- 9 - Loosen the clamps to the flexible exhaust coupling.
- 10 - Disconnect condensate drain line from the cold end header box.
- 11 - Disconnect condensate drain tubing from flue collar. Remove screws that secures the flue collar into place. Remove flue collar. It may be necessary to cut the exiting exhaust pipe for removal of the fitting.
- 12 - Mark and disconnect all combustion air pressure tubing from cold end header collector box.
- 13 - Mark and remove wires from pressure switch assembly. Remove the assembly.. Keep tubing attached to pressure switches.
- 14 - Disconnect the plug from the combustion air inducer. Remove two screws which secure combustion air inducer to collector box. Remove combustion air inducer assembly. Remove ground wire from vest panel.
- 15 - Disconnect the condensate drain line.
- 16 - Remove electrical junction box from the side of the furnace.
- 17 - Mark and disconnect any remaining wiring to heating compartment components. Disengage strain relief bushing and pull wiring and bushing through the hole in the blower deck.
- 18 - Remove the primary limit from the vestibule panel.
- 19 - Remove two screws from the front cabinet flange at the blower deck. Spread cabinet sides slightly to allow clearance for removal of heat exchanger.



- 20 - Remove screws along vestibule sides and bottom which secure vestibule panel and heat exchanger assembly to cabinet. Remove two screws from blower rail which secure bottom heat exchanger flange. Remove heat exchanger from furnace cabinet.
- 21 - Reinstall replacement heat exchanger into cabinet making sure that the clamshells of the heat exchanger assembly is engaged properly into the support bracket on the blower deck. Remove the indoor blower to view this area through the blower opening.
- 22 - Re-secure the supporting screws along the vestibule sides and bottom to the cabinet.
- 23 - Reinstall cabinet screws on front flange at blower deck.
- 24 - Reinstall the primary limit on the vestibule panel.
- 25 - Route heating component wiring through hole in blower deck and reinsert strain relief bushing.
- 26 - Reinstall electrical junction box.
- 27 - Reinstall the cold end header box.
- 28 - Reinstall the combustion air inducer. Reconnect the plug to the wire harness.
- 29 - Reinstall pressure switches and reconnect pressure switch wiring.
- 30 - Carefully connect combustion air pressure switch tubing from pressure switches to proper ports on cold end header collector box.
- 31 - Reconnect condensate drain line to the cold end header box.
- 32 - Use securing screws to reinstall flue collar to the top cap on the furnace. Reconnect exhaust piping and exhaust drain tubing.
- 33 - Replace flexible exhaust adapter on combustion air inducer and flue collar. Secure using two existing hose clamps.
- 34 - Reinstall burner box assembly in vestibule area. Secure burner box assembly to vestibule panel using four existing screws. **Make sure burners line up in center of burner ports**
- 35 - Reconnect flame roll-out switch wires.
- 36 - Reconnect sensor wire and reconnect 2-pin plug from ignitor.
- 37 - Reinstall gas valve manifold assembly. Reconnect gas supply line to gas valve.
- 38 - Reconnect the combustion air intake pipe.
- 39 - Reinstall burner box cover.
- 40 - Reconnect wires to gas valve.
- 41 - Replace the blower compartment access panel.
- 42 - Reconnect gas supply piping. Turn on power and gas supply to unit.

- 43- Follow lighting instructions on unit nameplate to light and operate furnace for 5 minutes to ensure the furnace is operating properly.
- 44- Check all piping connections, factory and field, for gas leaks. Use a leak detecting solution or other preferred means.
- 45- Replace heating compartment access panel.

CAUTION

Some soaps used for leak detection are corrosive to certain metals. Carefully rinse piping thoroughly after leak test has been completed. Do not use matches, candles, flame or other sources of ignition to check for gas leaks.

Cleaning the Burner Assembly (if needed)

- 1 - Turn off electrical and gas power supplies to furnace. Remove upper and lower furnace access panels.
- 2 - Disconnect the wires from the gas valve.
- 3 - Remove the burner box cover (if equipped).
- 4 - Disconnect the gas supply line from the gas valve. Remove gas valve/manifold assembly.
- 5 - Mark and disconnect sensor wire from the sensor. Disconnect wires from flame rollout switches.
- 6 - Disconnect combustion air intake pipe. It may be necessary to cut the existing pipe to remove burner box assembly.
- 7 - Remove four screws which secure burner box assembly to vest panel. Remove burner box from the unit.
- 8 - Use the soft brush attachment on a vacuum cleaner to gently clean the face of the burners. Visually inspect the inside of the burners and crossovers for any blockage caused by foreign matter. Remove any blockage.
- 9 - Reinstall the burner box assembly using the existing four screws. Make sure that the burners line up in the center of the burner ports.
- 10 - Reconnect the sensor wire and reconnect the 2-pin plug to the ignitor wiring harness. Reconnect wires to flame rollout switches.
- 11 - Reinstall the gas valve manifold assembly. Reconnect the gas supply line to the gas valve. Reinstall the burner box cover.
- 12 - Reconnect wires to gas valve.
- 13 - Replace the blower compartment access panel.
- 14 - Refer to instruction on verifying gas and electrical connections when re-establishing supplies.
- 15 - Follow lighting instructions to light and operate furnace for 5 minutes to ensure that heat exchanger is clean and dry and that furnace is operating properly.
- 16 - Replace heating compartment access panel.

PARTS IDENTIFICATION
(Single-Stage Furnace Shown)

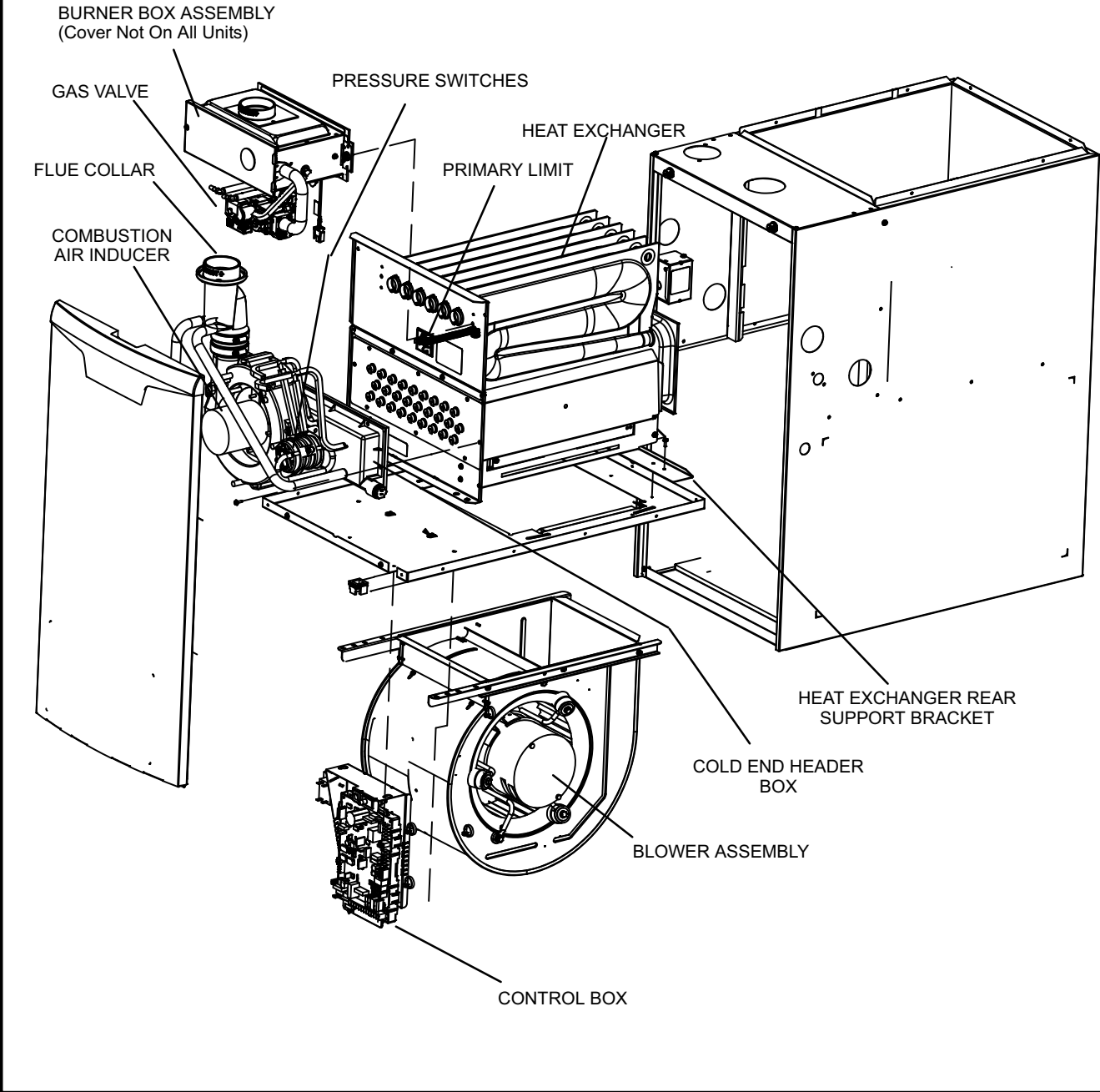

FIGURE 1