

PACKAGED UNITS KITS AND ACCESSORIES

507095-03
5/2022
Supersedes 12/2020

HEAT EXCHANGER REPLACEMENT KIT

INSTALLATION INSTRUCTIONS FOR HEAT EXCHANGER REPLACEMENT KIT USED ON LG/LD/KG/ZG 024, 036, 048, 060, 072, 074 PACKAGED ROOFTOP UNITS

Shipping and Packing List

Package 1 of 1 contains:

- 1- Heat exchanger assembly
- 1- Bag assembly containing:
 - 22-Screws
 - 1-CAB gasket
 - 6-Seals (mastic)
 - 5-Wire ties
 - 1-Foam PVC tape (17" length)

Check packaging for shipping damage. Contact the last carrier immediately if any shipping damage is found.

Application

See table for usage.

Cat. No. / Ass'y No.	Heat Output KBtuh	Material
99W41 / 610414-01	150	Aluminized
99W42 / 610414-02	105/108	Aluminized
99W43 / 610414-03	65/70	Aluminized
10M86 / 610414-04	65/70	Stainless Steel
13J82 / 610414-05	105/108	Stainless Steel
13J83 / 610414-06	150	Stainless Steel
13U10 / 610414-07	108K NOX ZG only	Aluminum
16G31 / 610414-08	150K 4 Stg.	Stainless Steel

⚠️ WARNING

Improper installation, adjustment, alteration, service or maintenance can cause property damage, personal injury or loss of life. Installation and service must be performed by a licensed professional HVAC installer or equivalent, service agency, or the gas supplier

⚠️ CAUTION

As with any mechanical equipment, contact with sharp sheet metal edges can result in personal injury. Take care while handling this equipment and wear gloves and protective clothing.

LG/LD/KG-Before Removing Heat Exchanger

Note - Do not damage roofing surface during replacement.

- 1- Disconnect all electrical power to unit and turn off main gas valve.
- 2- Disconnect power at the main breaker if the external disconnect is installed on the gas inlet mullion.
- 3- Disconnect gas inlet pipe at gas valve.
- 4- Open or remove heat and compressor access panels. See figure 1.

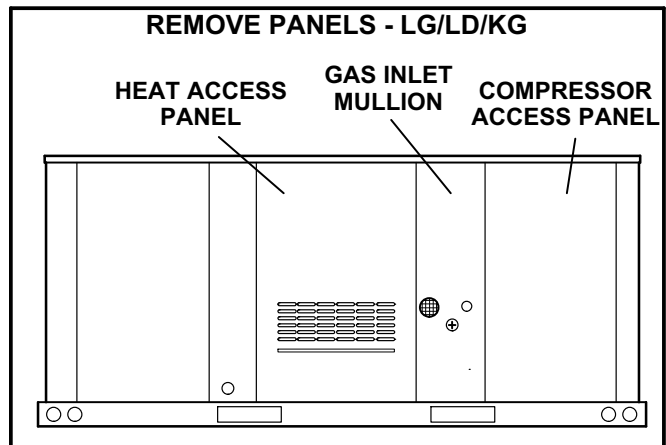

FIGURE 1

- 5- Remove the gas inlet mullion. See figure 1. If conduit is run to the mullion, move the mullion out of the way. Disconnect wiring and remove conduit if necessary.
 - 6- Disconnect P19 from J19. See figure 2.
 - 7- Disconnect wiring to ignitor, flame sensor, combustion air blower prove switch, and flame rollout switch. On LG/LD/KG/ZG units, disconnect wiring to the primary limit. See figure 2. On LGM150 units, remove the primary limit.
- Note - Wires are marked for identification during reassembly.*
- 8- Remove the two screws securing the combustion air blower prove switch. Discard the switch if tabs are broken. Retain the switch for reassembly if tabs are intact. See figure 2.
 - 9- Disconnect the air tubing to the fitting on the vestibule. See figure 3.

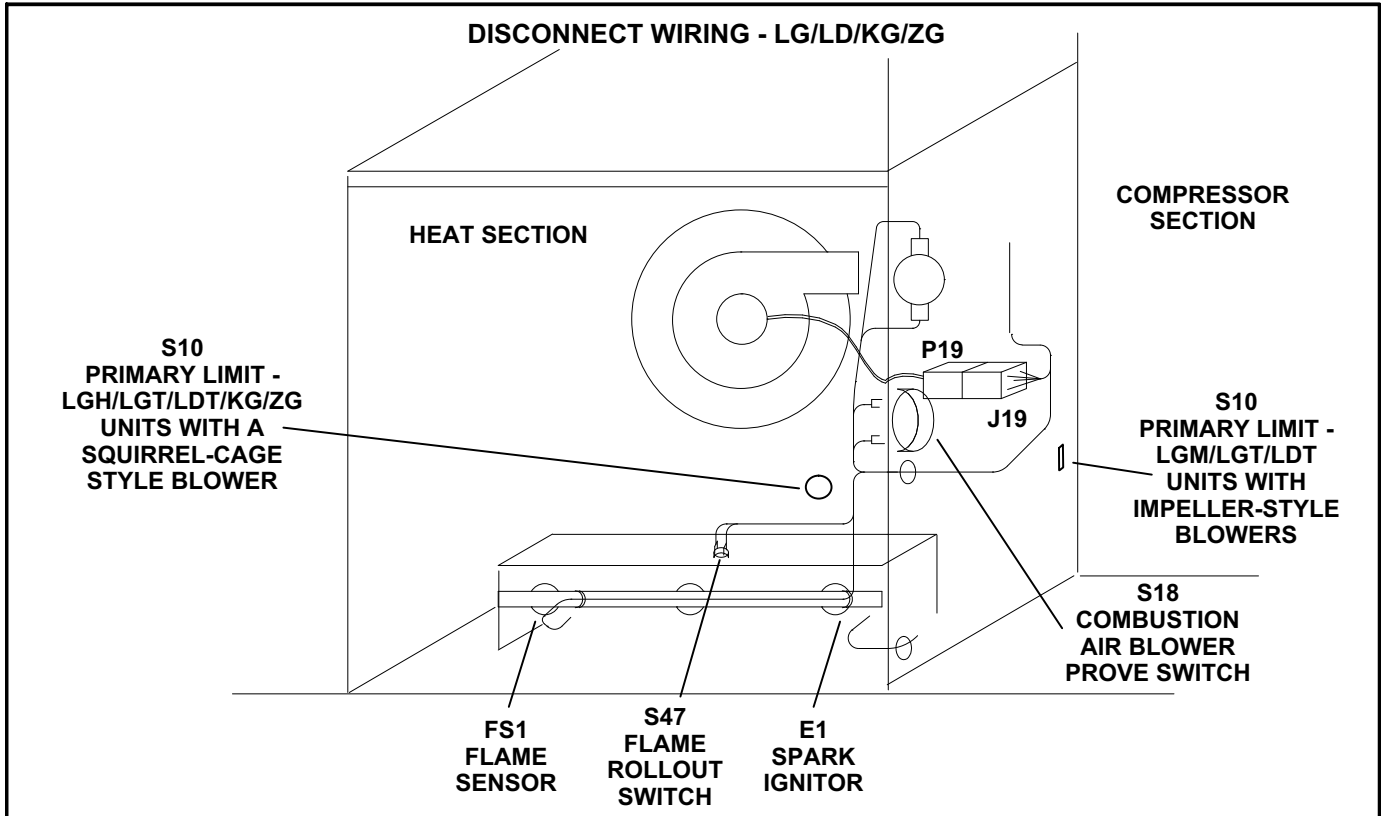

FIGURE 2

- 10- Remove the burner box assembly. Retain six screws holding the assembly in place. See figure 3.
- 11- Remove the vent connector from the combustion air inducer. See figure 3.
- 12- Remove the combustion air inducer. See figure 3.

- 13- Remove J19 from the division panel between the heat and compressor sections. See figure 2.
- 14- Remove 11 screws securing heat exchanger.

Remove Heat Exchanger - LG/LD/KG

Downflow Air Discharge Applications:

- 1- Remove the horizontal supply air panel.
- 2- Lift the back end of heat exchanger over the top of the supports and slide exchanger slightly toward the front of the unit. See figure 4.
- 3- Remove the heat exchanger from the front of the unit.

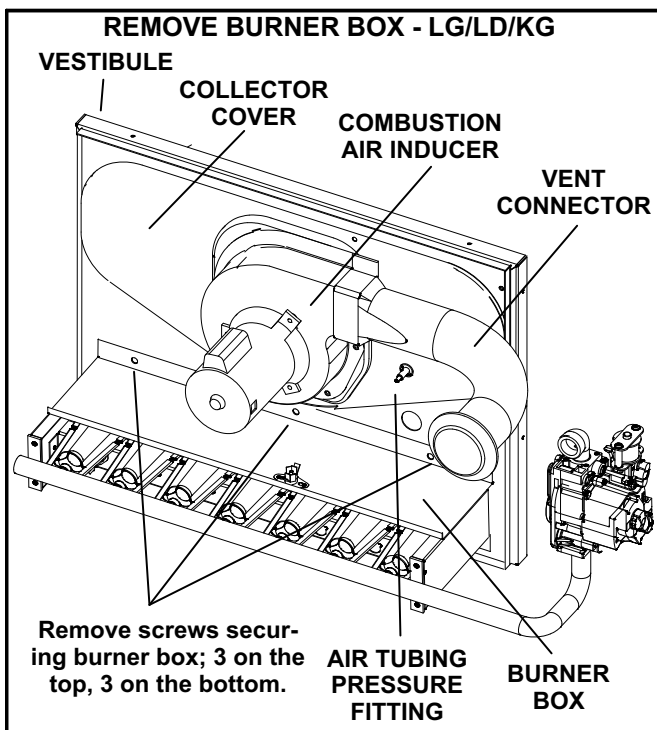

FIGURE 3

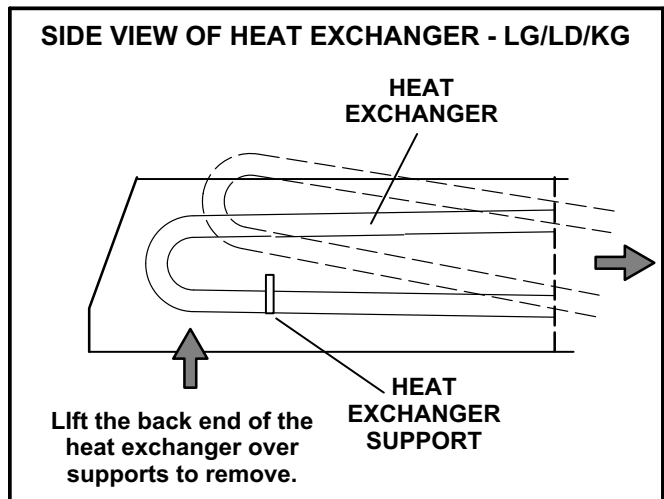

FIGURE 4

Horizontal Air Discharge - Direct Drive Blower:

1- LGH/LGT/LDT/KG Units With Squirrel-Cage Style Blowers -

Unplug the motor harness and remove 6 screws on the base of the blower housing. See figure 6. Lift the back side of the housing and remove from unit.

2- LGM/LGT/LDT Units With Impeller-Style Blowers-

Unplug the power and control harnesses to the motor. When present, disconnect wiring to the pressure sensor located on the blower housing. Remove four screws and slide blower out of unit. See figure 5.

3- Remove the heat exchanger as shown in figure 4.

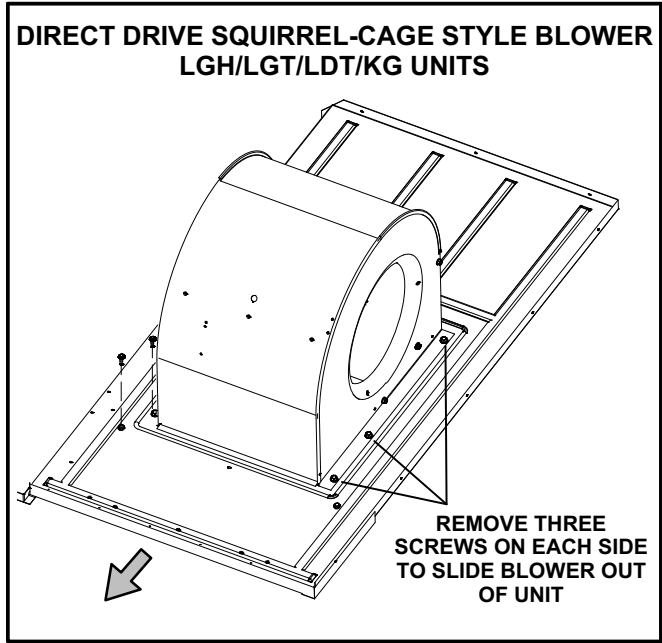

FIGURE 6

Horizontal Air Discharge - Belt Drive Blower:

1- Remove the belt.

2- Remove the motor mounting plate; do not remove the motor from the mounting plate. See figure 7.

3- Remove six screws securing blower housing in place. See figure 7. Pull the housing forward and tip the back upward to remove from unit.

4- Lift the back side of the housing and remove from unit.

5- Remove the heat exchanger as shown in figure 4.

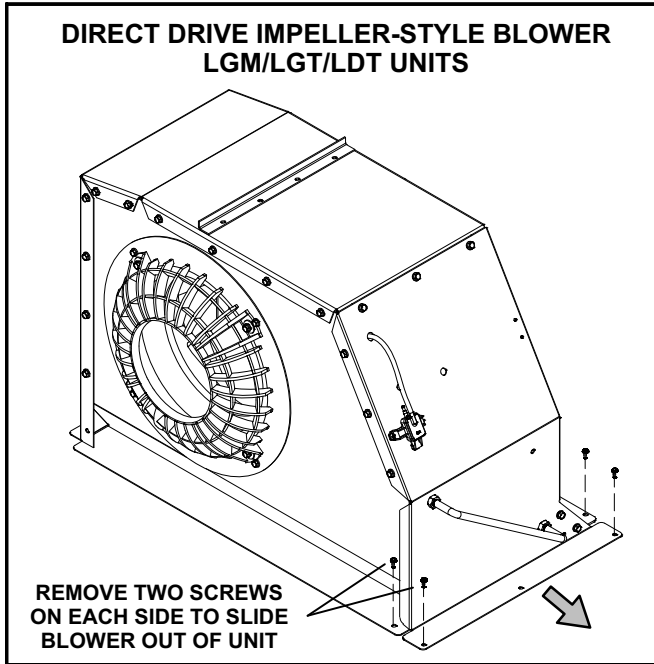

FIGURE 5

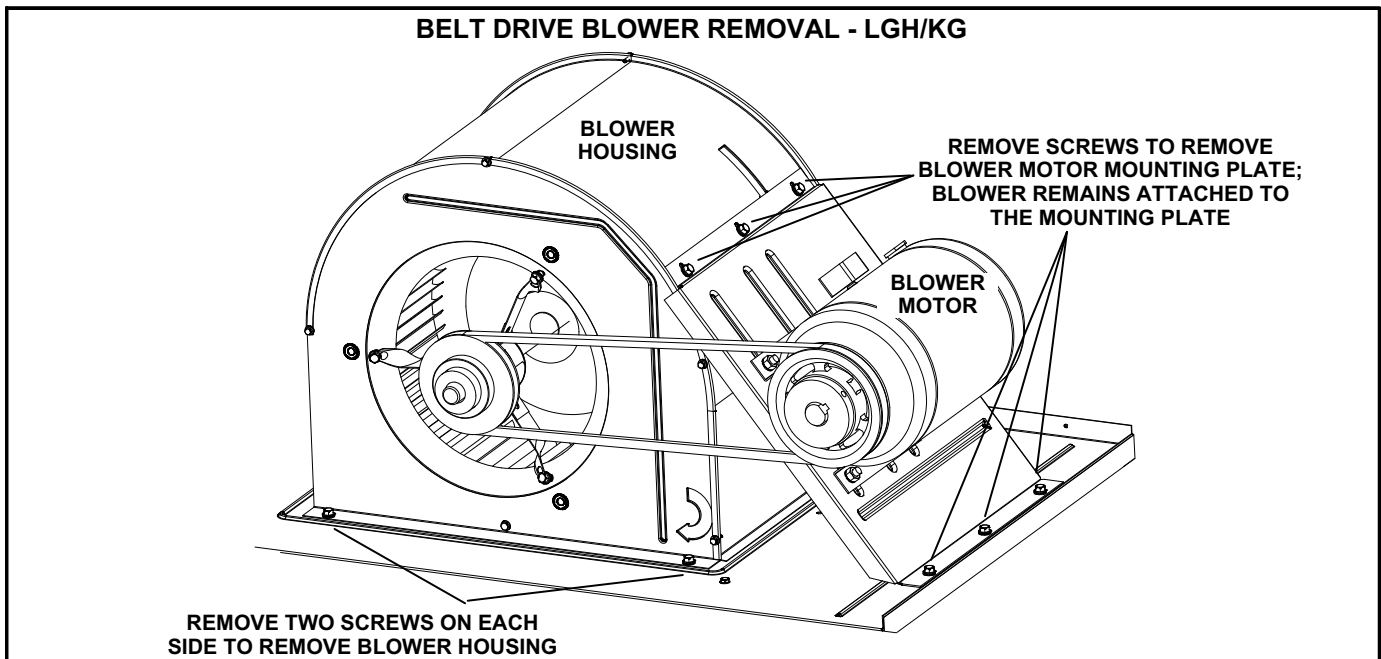

FIGURE 7

LG/LD/KG - Install New Heat Exchanger

- 1- Install replacement heat exchanger. Lift the back of the heat exchanger over the supports and push toward the back of the unit. Make sure tubes are secure in the support and the vestibule panel is tight against the opening frame. Secure with 11 retained screws.
- 2- Install the combustion air inducer gasket, provided in this kit, and the previously removed combustion air blower.
- 3- Reinstall vent connector.
- 4- *LGH/LGT/LDT/KG Units With Squirrel-Cage Style Blowers -*
See figure 6. Remove the two screws and patch plate covering the primary limit opening and discard.
LGM/LGT/LDT Units With Impeller-Style Blowers-
Do NOT remove the patch plate. This plate must be left in place.
- 5- Reinstall combustion air blower prove switch with retained screws. If damaged, install a new field-provided switch. Reinstall combustion air inducer air tubing.
- 6- Reinstall burner box assembly.
- 7- Reinstall J19 in division panel and connect P19.
- 8- Reconnect all wires and secure away from other components with wire ties. Reconnect all piping and mullions.
- 9- Check for gas leaks at gas connections.
- 10- Start unit blower according to unit installation instructions. Check for air leaks out of the gas heat area. Use high temperature RTV or mastic seals to seal any air leaking out of the gas heat compartment.
- 11- Start heating according to unit installation instructions. Check for proper operation of gas heat using lighting sequence provided in the unit installation instructions or lighting instruction label provided on unit.
- 12- In downflow applications remove the horizontal return air panel. This will prevent a slight amount of smoke from entering the building due to the residual manufacturing process lubrication on the surface of the heat exchanger. In horizontal airflow applications, inform building occupants there may be a slight amount of smoke entering the building.
- 13- Dispose of packing materials and replaced heat exchanger properly.

ZG - Remove Heat Exchanger

1- Turn main manual shut-off valve off and turn off electrical supply to unit.

2- Open access panels as shown in figure 8.

IMPORTANT - Remove and retain the speed nut that holds the heat exchanger bracket to the panel. The speed nut will be used when replacing the bracket and panel.

3- Remove the gas manifold. See figure 9.

4- Remove the burner box assembly. Retain six screws holding the assembly in place. See figure 9.

5- Disconnect wiring to the ignitor, flame sensor, combustion air prove switch, flame roll-out switch and primary limit. See figures 9 and 10.

6- Remove the primary limit. See figure 10.

7- Remove the vent connector from the combustion air inducer. See figure 10.

8- Remove the combustion air inducer. See figure 10.

9- Remove screws securing heat exchanger to unit. Rotate two parts on the front side of the frame and remove heat exchanger. See figure 11.

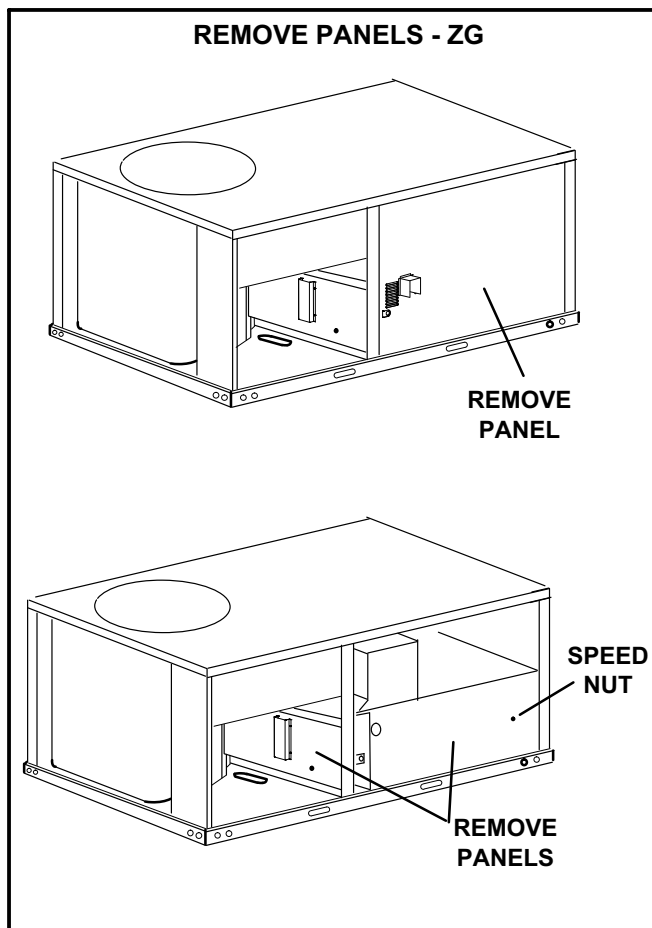

FIGURE 8

Note - Take care not to tear insulation when removing or installing heat exchanger.

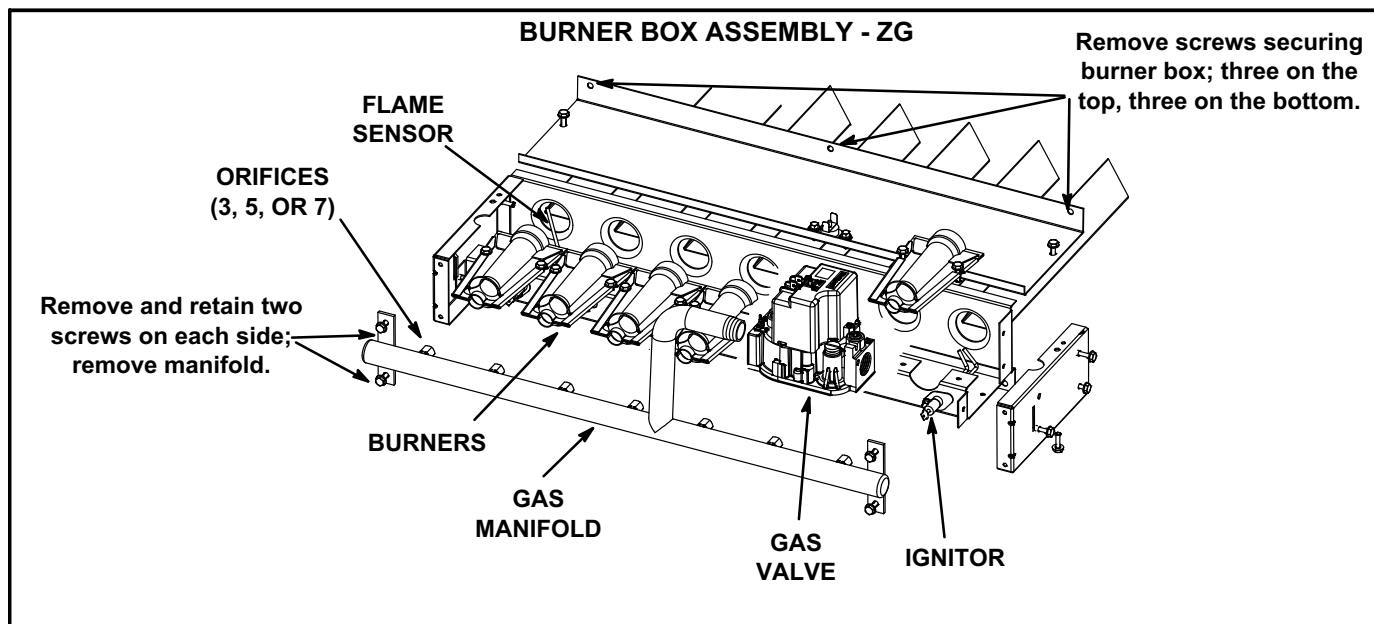

FIGURE 9

ZG - Replace Heat Exchanger

- 1- Install the combustion air inducer gasket, provided in this kit, and the previously removed combustion air blower.
- 2- Set replacement heat exchanger in unit, rotate frame front pieces in place and secure heat exchanger with screws.

Note - Use an awl to line up screw holes. Install screws on the back side of the assembly before the front side. Tighten screws only after all screws are in place; this allows a small amount of movement to assist starting all screws.

- 3- Replace the burner box and secure in place with screws.

Note - To make installation easier, start the screw on the back, lower side of frame. Cut a slit in the back, lower screw hole on the burner box. Set the burner box in place, push down to force the slit over the partially-engaged screw and tighten screw.

- 4- Replace gas manifold.
- 5- Reinstall vent connector.
- 6- Remove the two screws and patch plate covering the primary limit opening and discard. Reinstall primary limit.
- 7- Connect wiring to primary limit, ignitor and flame sensor, gas valve, flame roll-out switch and combustion air inducer.
- 8- Connect combustion air prove switch plastic tubing to pressure port on heat exchanger vestibule.
- 9- Install heat exchanger support bracket and align hole in panel with end of bracket. Fit panel in place and secure bracket to the panel with retained speed nut.
- 10- Replace other panels and refer to unit installation instructions to start unit.
- 11- Start unit blower according to unit installation instructions. Check for air leaks out of the gas heat exchanger compartment. Use high temperature RTV or the mastic seals to seal any air leaking out of the gas heat compartment.

12- Start unit in heating mode according to unit installation instructions. Check for proper operation of gas heat using lighting sequence provided in the unit installation instructions or lighting instruction label provided on unit.

13- On initial start-up, a slight amount of smoke may enter the building due to the residual manufacturing process lubrication on the surface of the heat exchanger. In down flow applications, remove the horizontal supply air panel to dilute the smoke. In horizontal airflow applications, inform building occupants there may be a slight amount of smoke entering the building on initial start up.

14- Dispose of packing materials and replaced heat exchanger properly.

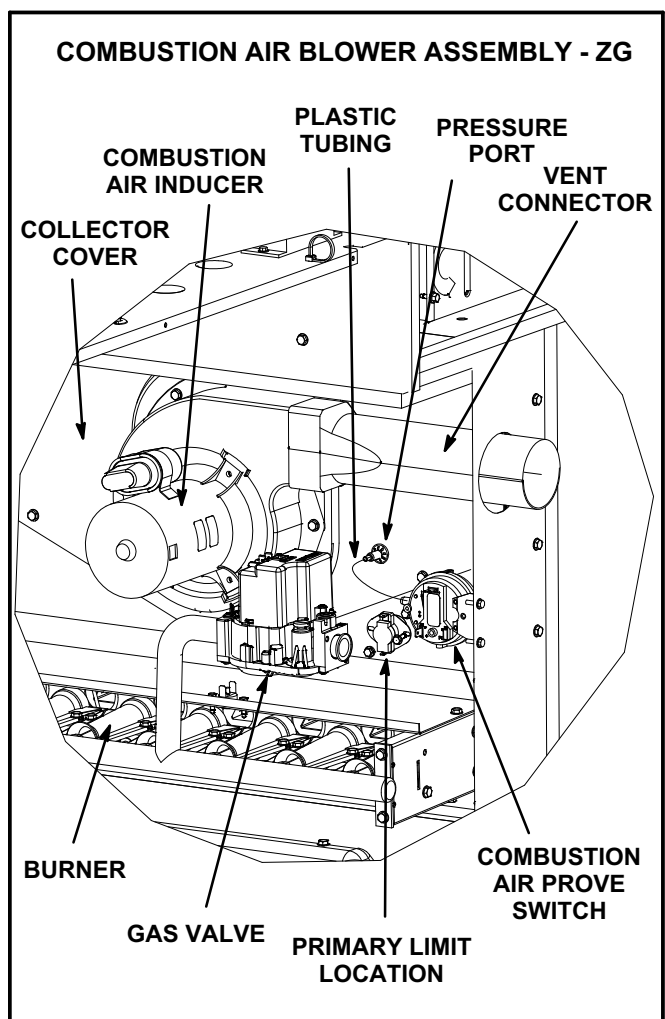

FIGURE 10

HEAT SECTION - ZG

**ROTATE TWO PARTS OF THE FRAME
OUT OF THE WAY BEFORE REMOVING
OR INSTALLING HEAT EXCHANGER**

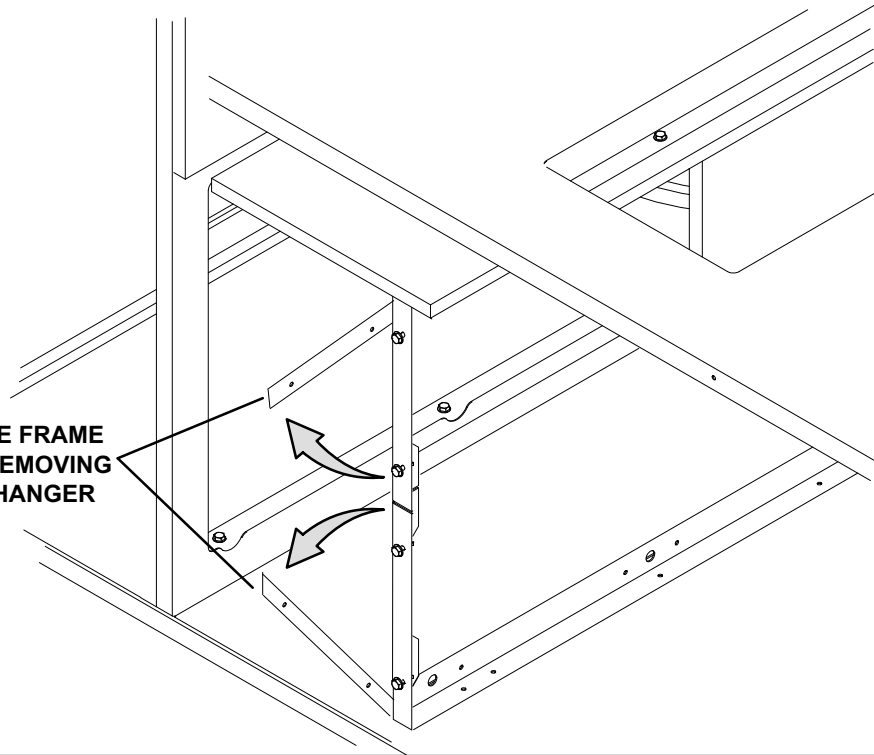

FIGURE 11