

INSTALLATION INSTRUCTIONS

⚠ WARNING

Improper installation, adjustment, alteration, service or maintenance can cause property damage, personal injury or loss of life. Installation and service must be performed by a licensed professional HVAC installer or equivalent, service agency, or the gas supplier

⚠ CAUTION

As with any mechanical equipment, contact with sharp sheet metal edges can result in personal injury. Take care while handling this equipment and wear gloves and protective clothing.

Table Of Contents

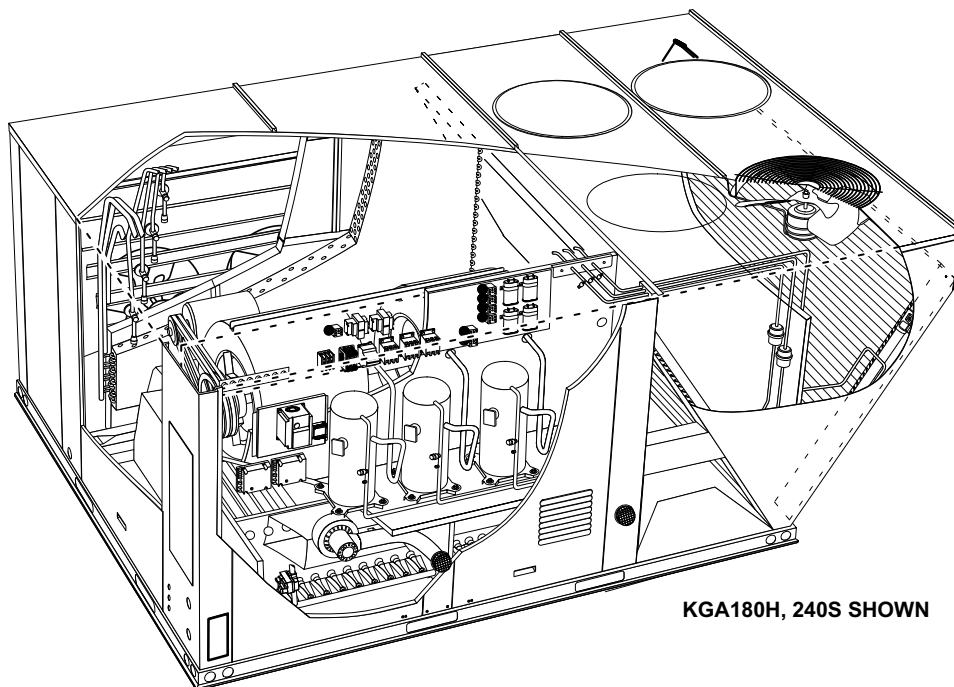
Dimensions	Page 2
Parts Arrangements	Page 4
Shipping and Packing List	Page 5
General	Page 5
Safety	Page 5
Unit Support	Page 6
Duct Connection	Page 6
Rigging Unit For Lifting	Page 7
Condensate Drains	Page 7
Gas Piping	Page 7
Pressure Test Gas Piping	Page 8

KG/KC 156H	(13 Ton)
KG/KC 180S/H	(15 Ton)
KG/KC 210S/H	(17.5 Ton)
KG/KC 240S/H	(20 Ton)
KG/KC 300S	(25 Ton)

GAS AND COOLING PACKAGED UNITS
 507198-08
 8/2019
 Supersedes 507198-07

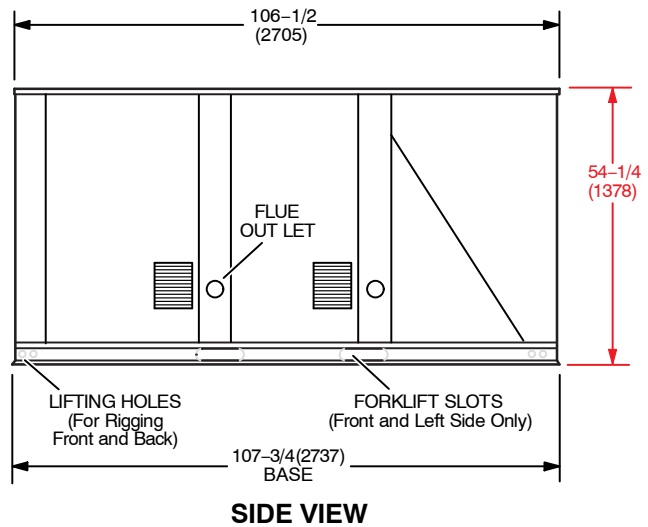
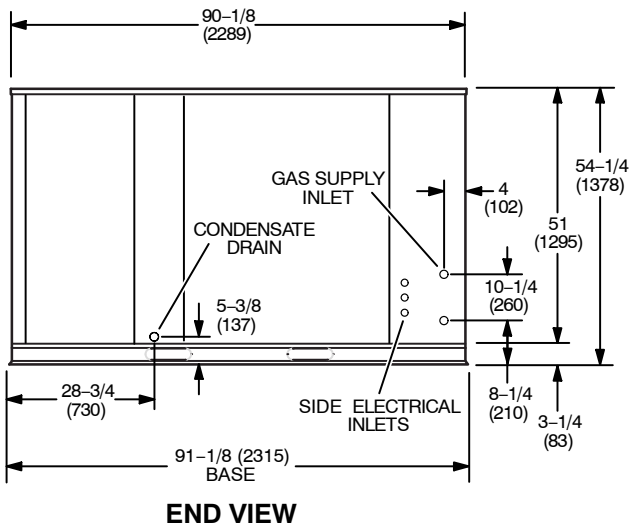
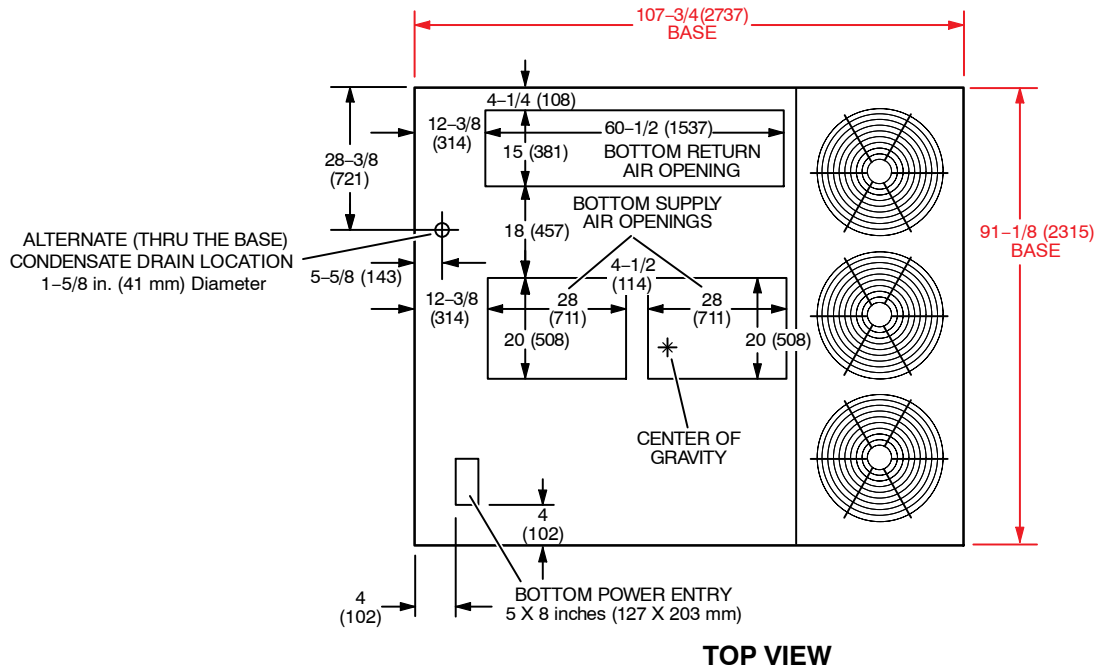
High Altitude Derate	Page 8
Electrical Connections	Page 8
Unit Power-Up	Page 10
Blower Operation and Adjustments	Page 10
Cooling Start-Up	Page 15
Gas Heat Start-Up	Page 38
Heating Operation and Adjustments	Page 39
Electric Heat	Page 40
Supply Air Inverter	Page 40
Hot Gas Reheat Operation and Start-Up	Page 42
Service	Page 45

RETAIN THESE INSTRUCTIONS FOR FUTURE REFERENCE



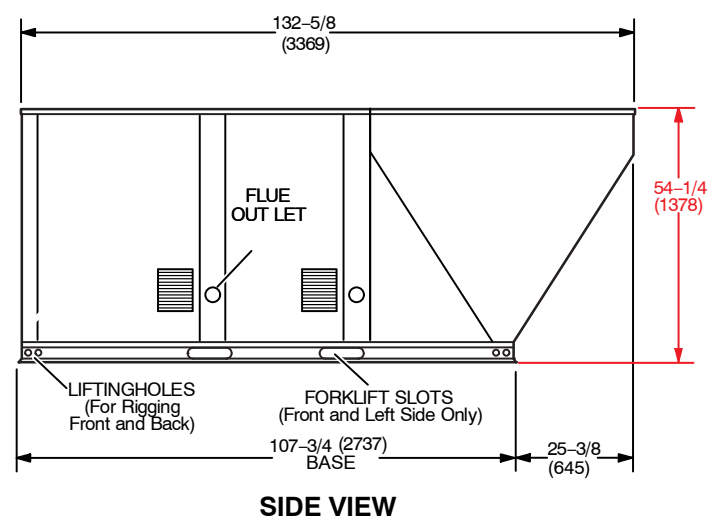
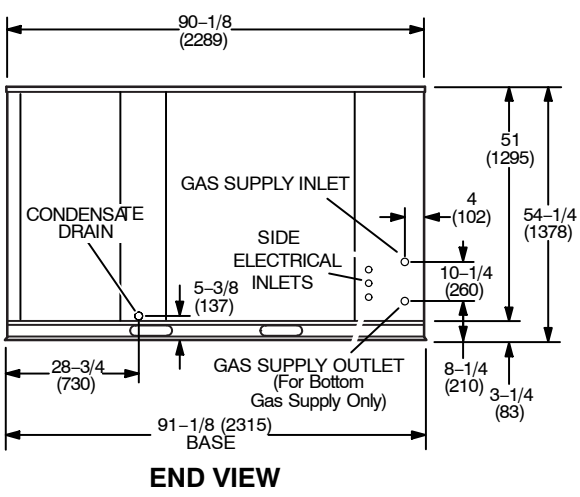
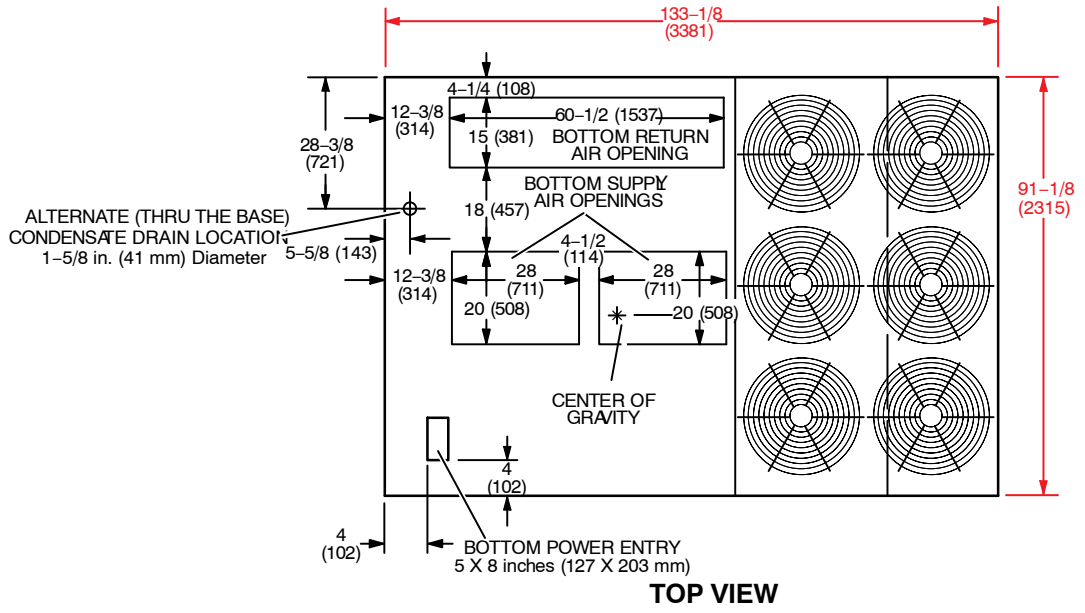
KGA180H, 240S SHOWN

KG/KC 156H, 180S, 210S DIMENSIONS - Electric heat section shown

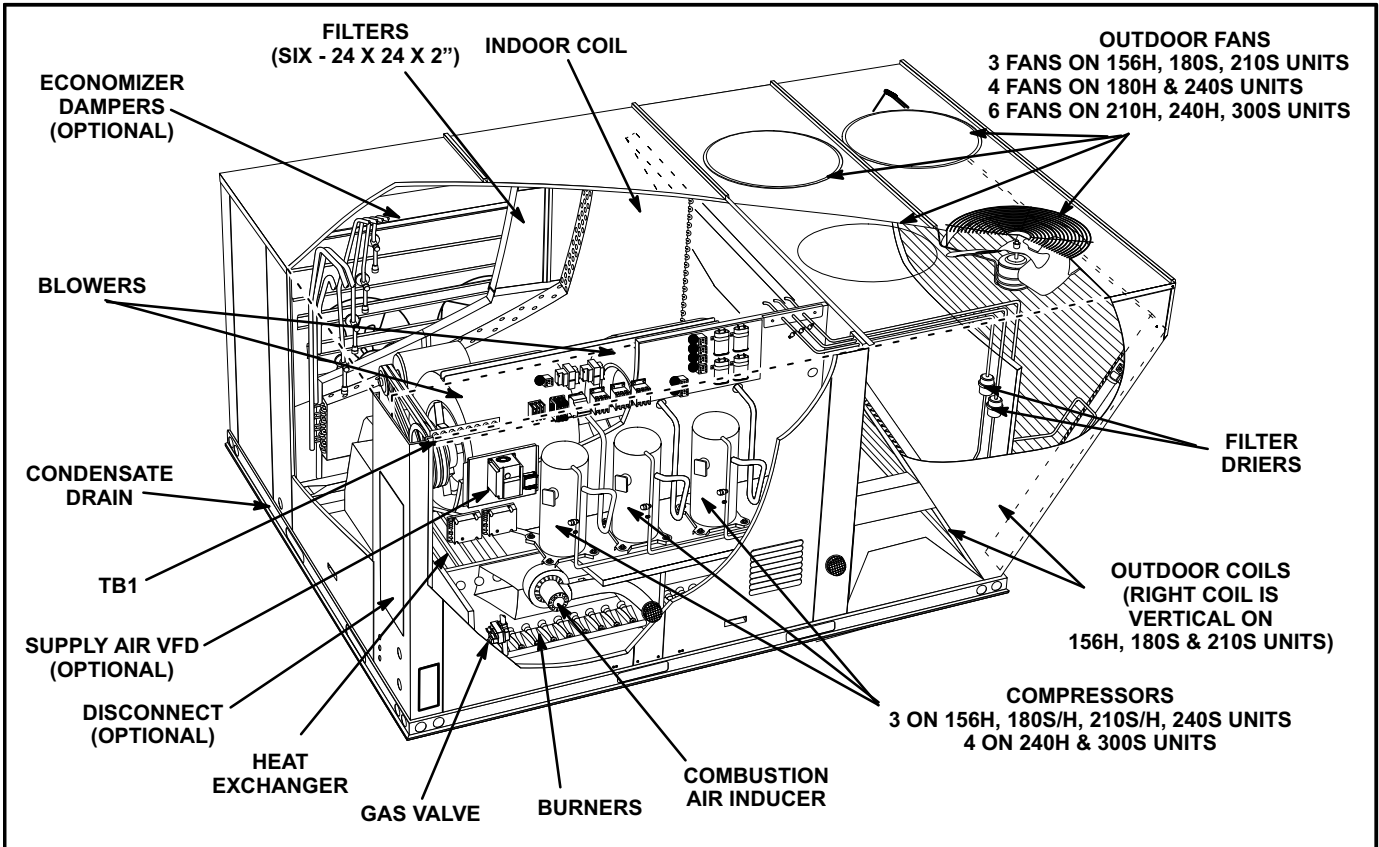


KG/KC 180H, 210H 240S/H, 300S DIMENSIONS - Electric heat section shown

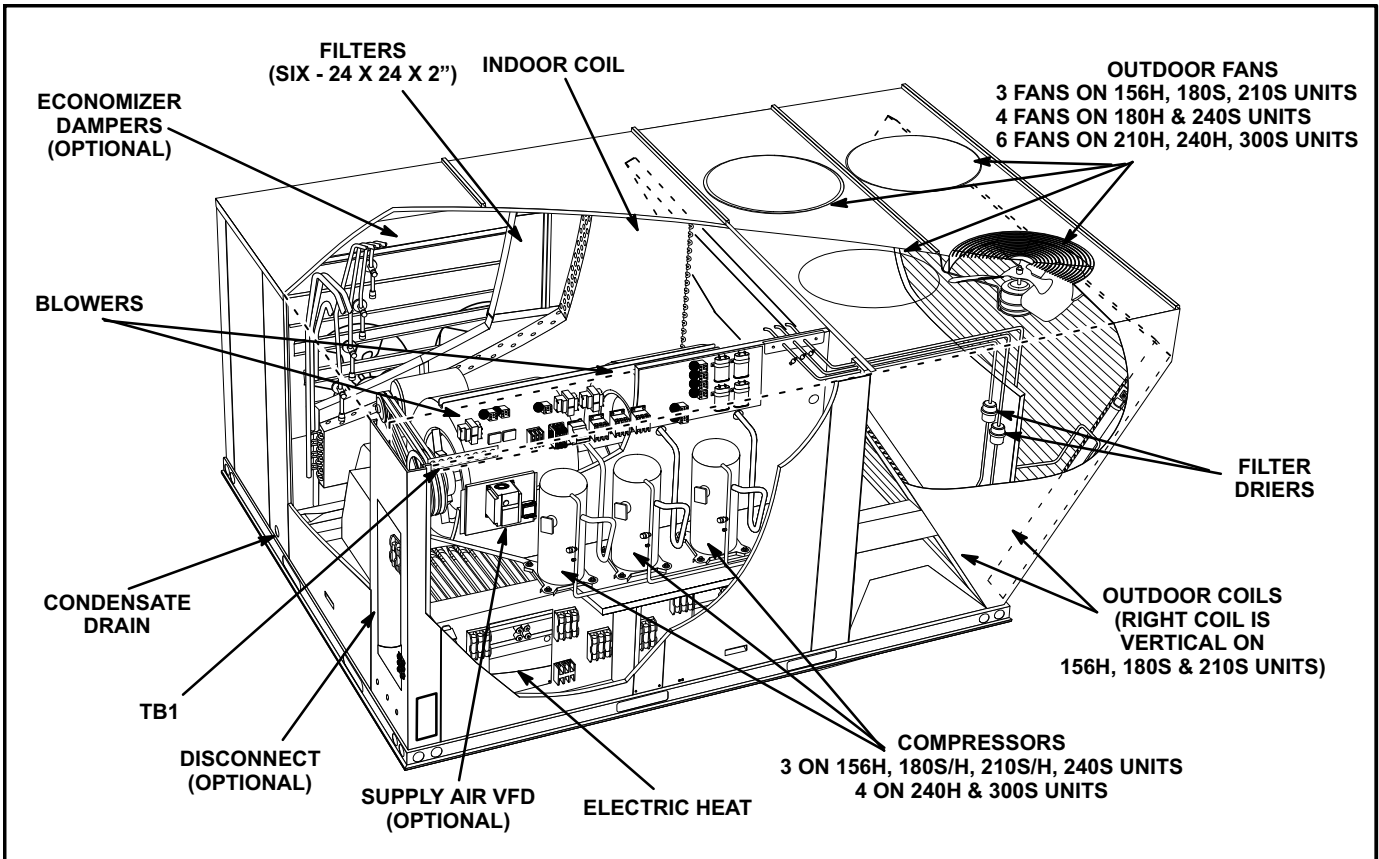
Note: 180H, 240S have four condenser fans.



KG PARTS ARRANGEMENT



KC PARTS ARRANGEMENT



Shipping and Packing List

Package 1 of 1 contains:

1- Assembled unit

Check unit for shipping damage. Receiving party should contact last carrier immediately if shipping damage is found.

General

These instructions are intended as a general guide and do not supersede local codes in any way. Authorities having jurisdiction should be consulted before installation.

The KG 156H gas/electric packaged rooftop unit is available in two Btuh heating inputs; KG 180-300 is available in three Btuh heating inputs. The KC cooling packaged rooftop unit is the same basic design as the KG unit except for the heating section. KG and KC units have identical refrigerant circuits with respective 13, 15, 17-1/2, 20, and 25 ton cooling capacities.

Units equipped with an optional supply air inverter are available. The blower will operate at lower speeds when cooling demand is low and increase to higher speeds when cooling demand is high. Refer to Inverter Start-Up section.

All units come default with a lightweight, all-aluminum condenser coil. Standard units are available with an optional, factory-installed fin/tube condenser coil.

Standard efficiency units equipped with fin/tube outdoor coils are available with an optional hot gas reheat coil which provides a dehumidifying mode of operation. Refer to Reheat Operation section.

Availability of units and options varies by brand.

Safety

See figure 1 for unit clearances.

Use of this unit as a construction heater or air conditioner is not recommended during any phase of construction. Very low return air temperatures, harmful vapors and operation of the unit with clogged or misplaced filters will damage the unit.

If this unit has been used for heating or cooling of buildings or structures under construction, the following conditions must be met or the warranty will be void:

- The vent hood must be installed per these installation instructions.
- A room thermostat must control the unit. The use of fixed jumpers that will provide continuous heating or cooling is not allowed.

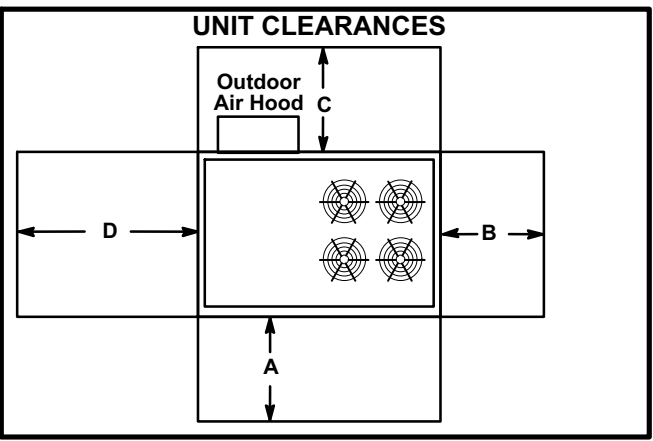


FIGURE 1

¹ Unit Clearance	A in.(mm)	B in.(mm)	C in.(mm)	D in.(mm)	Top Clearance
Service Clearance	60 (1524)	36 (914)	36 (914)	66 (1676)	Unob- structed
Clearance to Combustibles	36 (914)	1 (25)	1 (25)	1 (25)	Unob- structed
Minimum Operation Clearance	45 (1143)	36 (914)	36 (914)	41 (1041)	Unob- structed

Note - Entire perimeter of unit base requires support when elevated above mounting surface.

- ¹**Service Clearance** - Required for removal of serviceable parts.
- Clearance to Combustibles** - Required clearance to combustible material (gas units).
- Minimum Operation Clearance** - Required clearance for proper unit operation.
 - A pre-filter must be installed at the entry to the return air duct.
 - The return air duct must be provided and sealed to the unit.
 - Return air temperature range between 55°F (13°C) and 80°F (27°C) must be maintained.
 - Air filters must be replaced and pre-filters must be removed upon construction completion.
 - The input rate and temperature rise must be set per the unit rating plate.
 - The heat exchanger, components, duct system, air filters and evaporator coil must be thoroughly cleaned following final construction clean-up.
 - The unit operating conditions (including airflow, cooling operation, ignition, input rate, temperature rise and venting) must be verified according to these installation instructions.

⚠ WARNING

Electric shock hazard and danger of explosion. Can cause injury, death or product or property damage. Turn off gas and electrical power to unit before performing any maintenance or servicing operations on the unit. Follow lighting instructions attached to unit when putting unit back into operation and after service or maintenance.

⚠️ NOTICE

Roof Damage!

This system contains both refrigerant and oil. Some rubber roofing material may absorb oil, causing the rubber to swell. Bubbles in the rubber roofing material can cause leaks. Protect the roof surface to avoid exposure to refrigerant and oil during service and installation. Failure to follow this notice could result in damage to roof surface.

⚠️ IMPORTANT

The Clean Air Act of 1990 bans the intentional venting of refrigerant (CFC's and HCFC's) as of July 1, 1992. Approved methods of recovery, recycling or reclaiming must be followed. Fines and/or incarceration may be levied for non-compliance.

Unit Support

In downflow discharge installations, install the unit on a non-combustible surface only. Unit may be installed on combustible surfaces when used in horizontal discharge applications or in downflow discharge applications when installed on an LARMF18/36 roof mounting frame.

NOTE - Securely fasten roof frame to roof per local codes.

⚠️ CAUTION

To reduce the likelihood of supply / return air bypass and promote a proper seal with the RTU, duct work / duct drops / diffuser assemblies must be supported independently to the building structure.

A-Downflow Discharge Application

Roof Mounting with LARMF18/36

- 1- The LARMF roof mounting frame must be installed, flashed and sealed in accordance with the instructions provided with the frame.
- 2- The LARMF roof mounting frame should be square and level to 1/16" per linear foot (5mm per linear meter) in any direction.
- 3- Duct must be attached to the roof mounting frame and not to the unit; supply and return plenums must be installed before setting the unit.

Installer's Roof Mounting Frame

Many types of roof frames can be used to install the unit depending upon different roof structures. Items to keep in mind when using the building frame or supports are:

- 1- The base is fully enclosed and insulated, so an enclosed frame is not required.
- 2- The frames or supports must be constructed with non-combustible materials and should be square and

level to 1/16" per linear foot (5mm per linear meter) in any direction.

- 3- Frame or supports must be high enough to prevent any form of moisture from entering unit. Recommended minimum frame height is 14" (356mm).
- 4- Duct must be attached to the roof mounting frame and not to the unit. Supply and return plenums must be installed before setting the unit.
- 5- Units require support along all four sides of unit base. Supports must be constructed of steel or suitably treated wood materials.

NOTE-When installing a unit on a combustible surface for downflow discharge applications, a LARMF roof mounting frame is required.

B-Horizontal Discharge Applications

- 1- Units installed in horizontal airflow applications must use an LARMF horizontal roof mounting frame. The supply air duct connects to the LARMF horizontal supply air opening. The return air duct connected to the unit horizontal return air opening. Refer to unit dimensions.
- 2- Specified installation clearances must be maintained when installing units. Refer to figure 1.
- 3- Top of support slab should be approximately 4" (102mm) above the finished grade and located so no run-off water from higher ground can collect around the unit.
- 4- Units require support along all four sides of unit base. Supports must be constructed of steel or suitably treated wood materials.

Duct Connection

All exterior ducts, joints and openings in roof or building walls must be insulated and weather-proofed with flashing and sealing compounds in accordance with applicable codes. Any duct passing through an unconditioned space must be insulated.

⚠️ CAUTION

In downflow applications, do not drill or punch holes in base of unit. Leaking in roof may occur if unit base is punctured.

Rigging Unit For Lifting

Rig unit for lifting by attaching four cables to holes in unit base rail. See figure 2.

- 1- Detach wooden base protection before rigging.
- 2- Connect rigging to the unit base using both holes in each corner.
- 3- All panels must be in place for rigging.
- 4- Place field-provided H-style pick in place just above top edge of unit. Frame must be of adequate strength and length. (H-style pick prevents damage to unit.)

RIGGING		
Unit	*Weight	
	Lbs.	Kg.
KG 156H, 180S KC 156H, 180S, 210S	2440	1106
KG 180H, 210S KC 180H, 210H, 240S, 240H KH 180S	2650	1202
KG 210H, 240S, 240H, 300S KC 300S KH 240S	3005	1364

*Maximum weight with all accessories.

FIGURE 2

Condensate Drains

Remove plug and make drain connection to the 1" N.P.T. drain coupling provided on unit. A trap must be installed between drain connection and an open vent for proper condensate removal. See figure 3. It is sometimes acceptable to drain condensate onto the roof or grade; however, a tee should be fitted to the trap to direct condensate downward. The condensate line must be vented. Check local codes concerning condensate disposal. Refer to pages 1 and 2 for condensate drain location.

Note - The drain pan is made with a glass reinforced engineered plastic capable of withstanding typical joint torque but can be damaged with excessive force. Tighten pipe nipple hand tight and turn an additional quarter turn.

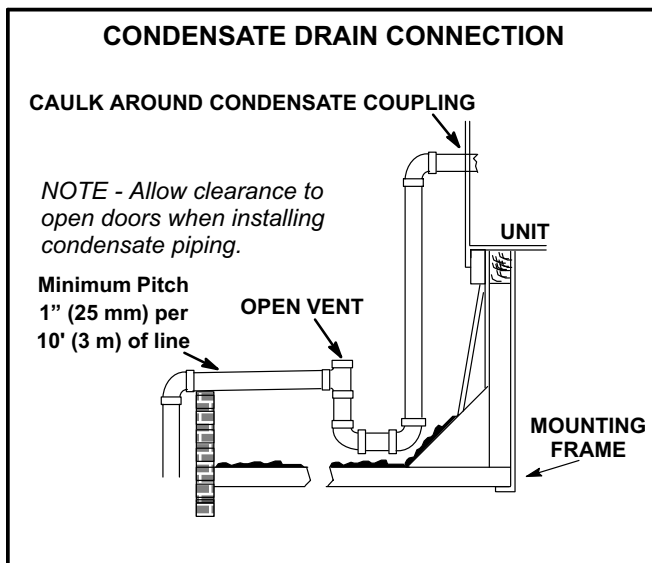


FIGURE 3

Connect Gas Piping (Gas Units)

Before connecting piping, check with gas company or authorities having jurisdiction for local code requirements. When installing gas supply piping, length of run from gas meter must be considered in determining pipe size for 0.5" w.c. (.12kPa) maximum pressure drop. Do not use supply pipe smaller than unit gas connection. For natural gas units, operating pressure at the unit gas connection must be a minimum of 4.7" w.c. (1.19kPa) and a maximum of 10.5" (2.60kPa) w.c. For LP/propane gas units, operating pressure at the unit gas connection must be a minimum of 10.8" w.c. (2.69kPa) and a maximum of 13.5" w.c. (3.36kPa).

When making piping connections a drip leg should be installed on vertical pipe runs to serve as a trap for sediment or condensate. A 1/8" N.P.T. plugged tap is located on gas valve for test gauge connection. Refer to Heating Start-Up section for tap location. Install a ground joint union between the gas control manifold and the main manual shut-off valve.

See figure 4 for gas supply piping entering outside the unit. A kit is required when gas supply piping enters through the bottom of the unit.

Compounds used on threaded joints of gas piping shall be resistant to the action of liquified petroleum gases.

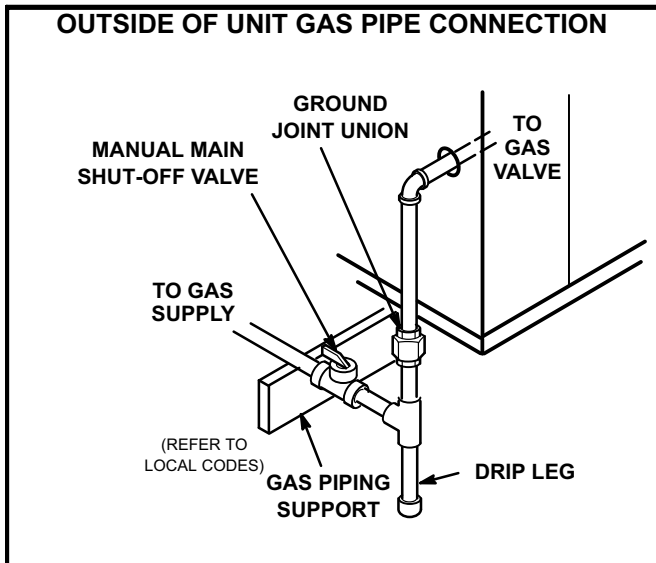


FIGURE 4

Pressure Test Gas Piping (Gas Units)

When pressure testing gas lines, the gas valve must be disconnected and isolated. Gas valves can be damaged if subjected to more than 0.5 psig (3.48kPa). See figure 5.


NOTE-Codes may require that manual main shut-off valve and union (furnished by installer) be installed in gas line external to unit. Union must be of the ground joint type.

After all connections have been made, check all piping connections for gas leaks. Also check existing unit gas connections up to the gas valve; loosening may occur during installation. Use a leak detection solution or other preferred means. Do not use matches candles or other sources of ignition to check for gas leaks.

⚠ CAUTION

Some soaps used for leak detection are corrosive to certain metals. Carefully rinse piping thoroughly after leak test has been completed. Do not use matches, candles, flame or othe sources of ignition to check for gas leaks.

⚠ WARNING

 Danger of explosion. Can cause injury or product or property damage. Do not use matches, candles, flame or other sources of ignition to check for leaks.

NOTE-In case emergency shut down is required, turn off the main manual shut-off valve and disconnect main power to unit. These devices should be properly labeled by the installer.

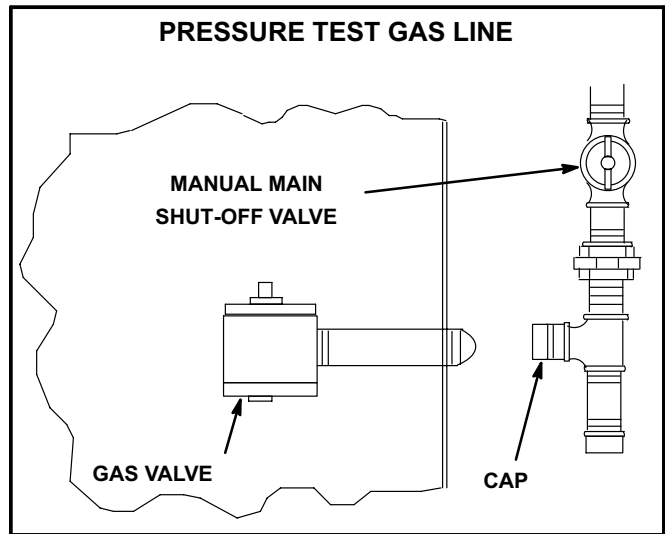


FIGURE 5

High Altitude Derate

Locate the high altitude conversion sticker in the unit literature bag. Fill out the conversion sticker and affix next to the unit nameplate.

Refer to table 1 for high altitude adjustments.

**TABLE 1
HIGH ALTITUDE DERATE**

Altitude Ft.*	Gas Manifold Pressure
2000-4500	See Unit Nameplate
4500 And Above	Derate 2% / 1000 Ft. Above Sea Level

*Units installed at 0-2000 feet do not need to be modified.

NOTE - This is the only permissible derate for these units.

Electrical Connections

Refer to inside of access panels for wiring diagrams.

POWER SUPPLY

Do not apply power or close disconnect switch until installation is complete. Refer to start-up directions. Refer closely to unit wiring diagram.

Refer to unit nameplate for minimum circuit ampacity and maximum fuse size.

- 1- Units are factory-wired for 240/460/575 volt supply. **For 208V supply**, remove the insulated terminal cover from the 208V terminal on the control transformer. Move the wire from the transformer 240V terminal to the 208V terminal. Place the insulated terminal cover on the unused 240V terminal.
- 2- Route power through the bottom power entry area. On KG units, connect wiring to L1, L2, and L3 on TB13 in the control area. On KC units, connect wiring to TB2 in the incoming power enclosure. Secure power wiring with wire ties provided in control box. See unit wiring diagram.

- 3- *Units With Optional 120v GFCI Outlet -*
Route and connect separate 120v wiring to GFCI outlets which do not have factory-installed wiring. Route field wiring in conduit between bottom power entry and GFCI. See figure 6.

CONTROL WIRING

A-Thermostat Location

Room thermostat mounts vertically on a standard 2" X 4" handy box or on any non-conductive flat surface.

Locate thermostat approximately 5 feet (1524mm) above the floor in an area with good air circulation at average temperature. Avoid locating the room thermostat where it might be affected by:

- drafts or dead spots behind doors and in corners
- hot or cold air from ducts
- radiant heat from sun or appliances
- concealed pipes and chimneys

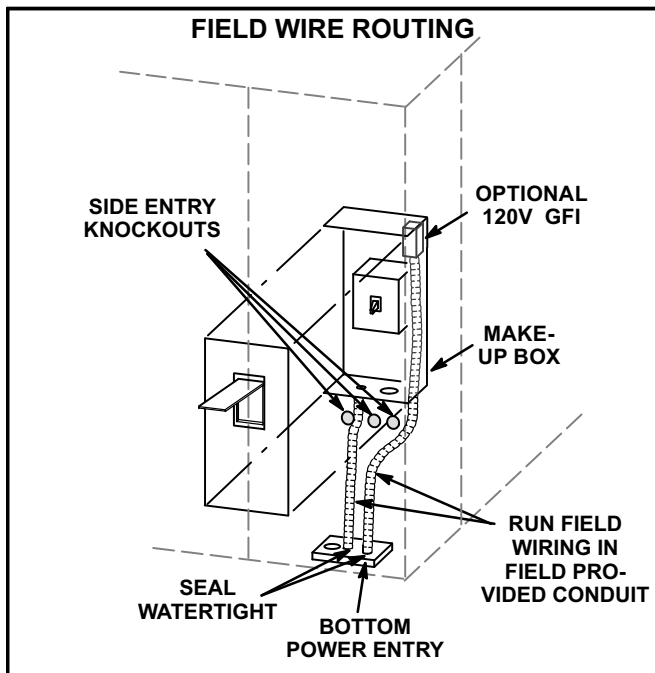


FIGURE 6

B-Thermostat Wiring

- 1- Route thermostat cable or wires from subbase to TB1 in control box (refer to unit dimensions to locate bottom and side power entry and parts arrangement for location of TB1).
- 2- On hot gas reheat units, route wires from the A20 dehumidistat switch to TB1 and TB37 in the control box.

IMPORTANT - Unless field thermostat wires are rated for maximum unit voltage, they must be routed away from line voltage wiring. Use wire ties located in control area to secure thermostat cable.

Use 18 AWG wire for all applications using remotely installed electro-mechanical and electronic thermostats.

- 3- Install in accordance with instructions provided with thermostat.
- 4- Connect thermostat wiring to TB1 terminal as shown in figure 7 for electro-mechanical and electronic thermostats. If using other temperature control devices or energy management systems see instructions and wiring diagram provided by manufacturer.

IMPORTANT- Terminal connections at the subbase and TB1 must be made securely. Loose control wire connections may allow unit to operate but not with proper response to room demand.

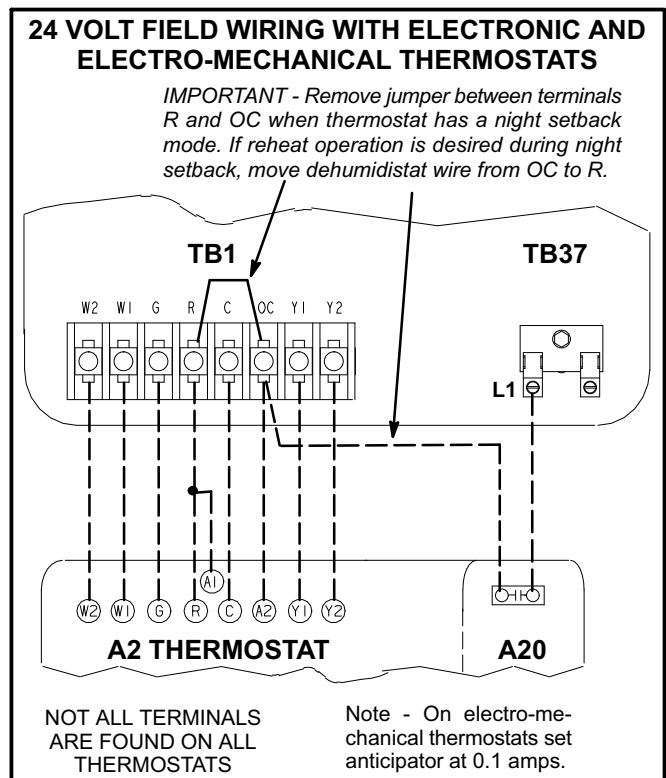


FIGURE 7

C-Hot Gas Reheat Units Only

Units require a dehumidify demand to initiate operation. A 24V input at TB37-L1 is required to energize reheat. A standalone dehumidistat (A20) and/or a room thermostat / energy management system with humidity sensing may be used. Refer to device manual for setup details.

- 1- When a dehumidistat is used, route wires from the A20 dehumidistat switch to the control box. Install dehumidistat assembly in accordance with instructions provided with the dehumidistat.
- 2- Connect dehumidistat and/or thermostat wiring to TB1 and TB37 as shown in figure 7.

IMPORTANT - Remove jumper between terminals R (24V) and OC when thermostat has a night setback mode. If reheat operation is desired during night setback, move dehumidistat wire from OC to R.

Note - When initially setting up some thermostats, a dehumidification mode must be enabled. When prompted by thermostat menus, select RTU/AUX DEHUMIDIFIER mode.

Unit Power-Up

- 1- Make sure that unit is installed in accordance with the installation instructions and applicable codes.
- 2- Inspect all electrical wiring, both field- and factory-installed, for loose connections. Tighten as required.
- 3- Check to ensure that refrigerant lines do not rub against the cabinet or against other refrigerant lines.
- 4- Check voltage at disconnect switch. Voltage must be within range listed on nameplate. If not, consult power company and have voltage condition corrected before starting unit.
- 5- Make sure filters are in place before start-up.
- 6- Apply power to unit.

Blower Operation and Adjustments

A-Three Phase Scroll Compressor Voltage Phasing

Three phase scroll compressors must be phased sequentially to ensure correct compressor and blower rotation and operation. Compressor and blower are wired in phase at the factory. Power wires are color-coded as follows: line 1-red, line 2-yellow, line 3-blue.

- 1- Observe suction and discharge pressures and blower rotation on unit start-up.
- 2- Suction pressure must drop, discharge pressure must rise, and blower rotation must match rotation marking.

If pressure differential is not observed or blower rotation is not correct:

- 3- Disconnect all remote electrical power supplies.
- 4- Reverse any two field-installed wires connected to the line side of TB2. Do not reverse wires at blower contactor.
- 5- Make sure the connections are tight.

Discharge and suction pressures should operate at their normal start-up ranges.

Supply Air Inverter Units - These units are equipped with a phase monitor located in the control compartment. The phase monitor will detect the phasing of incoming power. If the incoming power is out of phase or if any of the three phases are lost, the indicating LED on the phase monitor will turn red and the unit will not start. In normal operation with correct incoming power phasing, the LED will be green.

Note - The phase monitor is also offered as a field-installed option.

B-Blower Operation

Initiate blower demand at thermostat according to instructions provided with thermostat. Unit will cycle on thermostat demand. The following steps apply to applications using a typical electro-mechanical thermostat.

- 1- Blower operation is manually set at the thermostat subbase fan switch. With fan switch in **ON** position, blowers will operate continuously.
- 2- With fan switch in **AUTO** position, the blowers will cycle with heating or cooling demand. Blowers and entire unit will be off when system switch is in **OFF** position.

C-Blower Access

The blower assembly is secured to a sliding base which allows the entire assembly to be pulled out of the unit. See figure 8.

- 1- Remove the clamp which secures the blower wiring to the blower motor base.
- 2- Remove and retain screws on either side of sliding base. Pull base toward outside of unit. When pulling the base out further than 12" (305mm), disconnect wiring to K3 blower contactor T1, T2, and T3. Pull wiring toward blower to allow enough slack to slide the base out further.
- 3- Slide base back into original position when finished servicing. Replace the clamp and blower wiring in the previous location on the blower motor base. Reconnect wiring to K3 if it was disconnected.
- 4- Replace retained screws on either side of the sliding base.

D-Determining Unit CFM

IMPORTANT - Supply air inverter units are factory-set to run the blower at full speed when there is a blower (G) demand without a heating or cooling demand. Use the following procedure to adjust motor pulley to deliver the full load cooling or heating CFM. See Inverter Start-Up section to set blower CFM for all modes once the motor pulley is set.

- 1- The following measurements must be made with a dry indoor coil. Run blower without a cooling demand.

Measure the indoor blower shaft RPM. Air filters must be in place when measurements are taken.

- 2- With all access panels in place, measure static pressure external to unit (from supply to return). Blower performance data is based on static pressure readings taken in locations shown in figure 9.

Note - Static pressure readings can vary if not taken where shown.

- 3- Referring to page 13, use static pressure and RPM readings to determine unit CFM. Use page 14 when installing units with any of the optional accessories listed.

- 4- The blower RPM can be adjusted at the motor pulley. Loosen Allen screw and turn adjustable pulley clockwise to increase RPM. Turn counterclockwise to decrease RPM. See figure 8. Tighten Allen screw after adjusting. Do not exceed minimum and maximum number of pulley turns as shown in table 2.

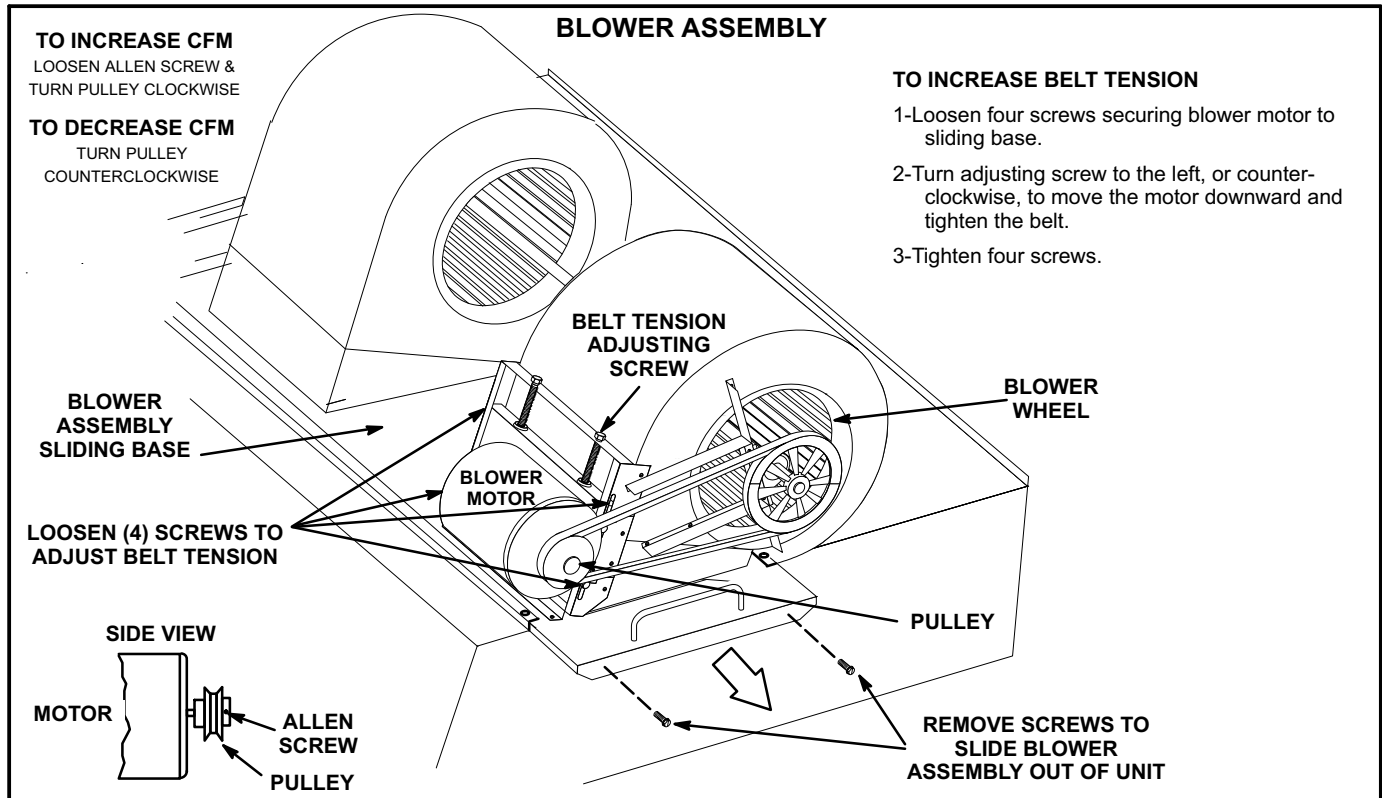


FIGURE 8

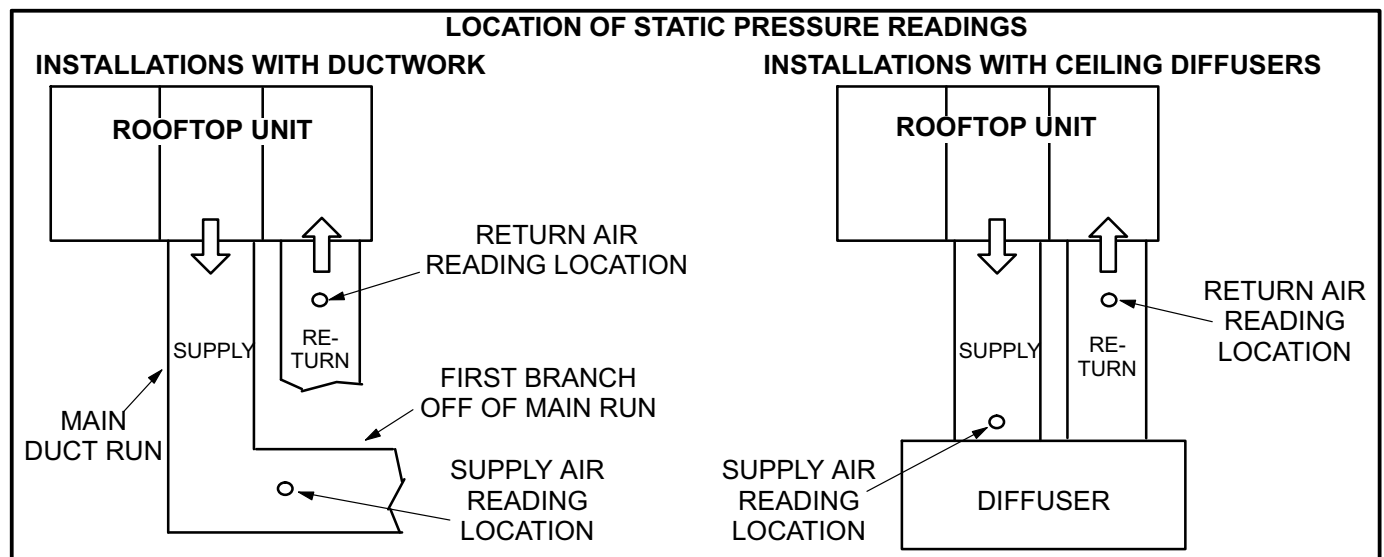


FIGURE 9

**TABLE 2
MINIMUM AND MAXIMUM PULLEY ADJUSTMENT**

Belt	Min. Turns Open	Max. Turns Open
A Section	No minimum	5
B Section	1*	6

*No minimum number of turns open when B belt is used on pulleys 6" O.D. or larger.

E-Blower Belt Adjustment

Maximum life and wear can be obtained from belts only if proper pulley alignment and belt tension are maintained. Tension new belts after a **24-48** hour period of operation. This will allow belt to stretch and seat into pulley grooves. Make sure blower and motor pulley are aligned as shown in figure 10.

1- Loosen four bolts securing motor base to mounting frame. See figure 8.

2- *To increase belt tension -*

Turn adjusting bolt to the left, or counterclockwise, to move the motor outward and tighten the belt. This increases the distance between the blower motor shaft and the blower housing shaft.

To loosen belt tension -

Turn the adjusting bolt to the right, or clockwise to loosen belt tension.

3- Tighten two bolts on motor pulley side.

IMPORTANT - Align top edges of blower motor base and mounting frame base parallel before tightening two bolts on the other side of base. Motor shaft and blower shaft must be parallel.

4- Tighten two bolts on other side of base.

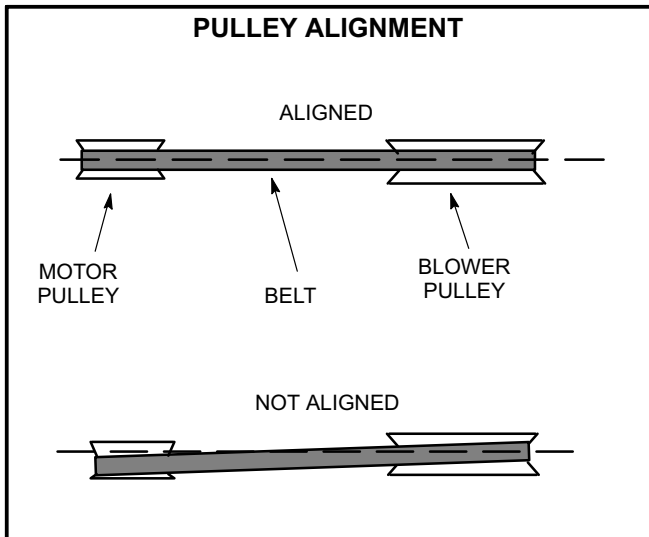


FIGURE 10

F-Check Belt Tension

Overtensioning belts shortens belt and bearing life. Check belt tension as follows:

1- Measure span length X. See figure 11.

2- Apply perpendicular force to center of span (X) with enough pressure to deflect belt 1/64" for every inch of span length or 1.5mm per 100mm of span length.

Example: Deflection distance of a 40" span would be 40/64" or 5/8".

Example: Deflection distance of a 400mm span would be 6mm.

3- Measure belt deflection force. For a used belt, the deflection force should be 5 lbs. (35kPa). A new belt deflection force should be 7 lbs. (48kPa).

A force below these values indicates an undertensioned belt. A force above these values indicates an overtensioned belt.

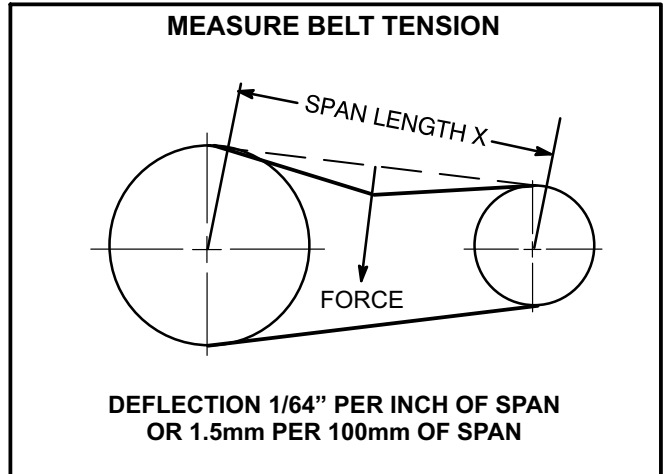


FIGURE 11

G-Field-Furnished Blower Drives

For field-furnished blower drives, use page 13 to determine BHP and RPM required. Reference page 14 to determine the drive number and table 3 to determine the manufacturer's model number

BLOWER DATA

BLOWER TABLE INCLUDES RESISTANCE FOR BASE UNIT ONLY WITH DRY INDOOR COIL & AIR FILTERS IN PLACE FOR ALL UNITS ADD:

- 1 - Wet indoor coil air resistance of selected unit.
- 2 - Any factory installed options air resistance (electric heat, economizer, etc.)
- 3 - Any field installed accessories air resistance (electric heat, duct resistance, diffuser, etc.)

Then determine from blower table blower motor output and drive required.

See page 14 for wet coil and option/accessory air resistance data. See page 14 for factory installed drive kit specifications.

MINIMUM AIR VOLUME REQUIRED FOR DIFFERENT GAS HEAT SIZES - Standard (S) and Medium Heat (M) - 4500 cfm minimum. High Heat (H) - 5125 cfm minimum.

MINIMUM AIR VOLUME REQUIRED FOR USE WITH OPTIONAL ELECTRIC HEAT - KCA156H units require 5200cfm minimum air with electric heat. All other units require 6000 cfm minimum air with electric heat.

Air Volume cfm	TOTAL STATIC PRESSURE - Inches Water Gauge (Pa)																									
	0.20		0.40		0.60		0.80		1.00		1.20		1.40		1.60		1.80		2.00		2.20		2.40		2.60	
	RPM	BHP	RPM	BHP	RPM	BHP	RPM	BHP	RPM	BHP	RPM	BHP	RPM	BHP	RPM	BHP	RPM	BHP	RPM	BHP	RPM	BHP	RPM	BHP	RPM	BHP
2750	385	0.30	505	0.50	600	0.70	680	0.90	755	1.10	820	1.30	885	1.70	950	2.10	1005	2.55	1060	3.00	1110	3.30	1160	3.85	1205	4.15
3000	395	0.35	515	0.55	610	0.75	685	1.00	760	1.20	825	1.45	890	1.85	955	2.25	1005	2.70	1070	3.25	1115	3.55	1165	4.10	1210	4.45
3250	405	0.40	520	0.60	615	0.85	695	1.10	765	1.30	830	1.60	895	2.00	960	2.40	1010	2.90	1075	3.45	1120	3.75	1175	4.35	1215	4.70
3500	415	0.45	530	0.70	620	0.95	700	1.20	775	1.45	840	1.70	900	2.15	965	2.55	1015	3.05	1080	3.65	1130	4.05	1180	4.65	1225	5.00
3750	425	0.50	540	0.75	630	1.05	710	1.30	780	1.60	845	1.85	905	2.25	970	2.65	1020	3.15	1095	3.85	1145	4.45	1195	5.05	1240	5.30
4000	435	0.55	545	0.85	635	1.10	715	1.40	785	1.70	850	2.00	910	2.30	965	2.80	1025	3.30	1100	4.00	1150	4.60	1200	5.20	1235	5.60
4250	445	0.60	555	0.90	645	1.25	725	1.55	795	1.85	855	2.15	915	2.45	970	2.85	1035	3.35	1110	4.15	1160	4.75	1210	5.35	1250	5.90
4500	455	0.70	565	1.00	655	1.35	730	1.65	800	2.00	865	2.35	925	2.65	980	3.00	1040	3.55	1120	4.25	1170	4.85	1220	5.45	1260	6.25
4750	470	0.75	575	1.10	660	1.45	740	1.80	810	2.15	870	2.50	930	2.85	985	3.20	1040	3.80	1120	4.40	1170	5.00	1220	5.60	1260	6.50
5000	480	0.85	585	1.25	670	1.60	750	1.95	815	2.30	880	2.70	940	3.05	995	3.40	1045	3.80	1120	4.40	1170	5.00	1220	5.60	1260	6.50
5250	495	0.95	595	1.35	680	1.70	755	2.10	825	2.50	890	2.90	945	3.25	1000	3.65	1050	4.00	1130	4.40	1180	5.00	1230	5.50	1270	7.25
5500	505	1.05	605	1.45	690	1.85	765	2.25	835	2.65	895	3.05	950	3.45	1005	3.80	1055	4.20	1135	4.60	1185	5.20	1235	5.80	1275	7.60
5750	520	1.15	615	1.60	700	2.00	775	2.45	840	2.85	905	3.25	960	3.65	1015	4.10	1065	4.50	1140	4.70	1190	5.30	1240	5.80	1285	8.00
6000	530	1.30	630	1.75	710	2.15	785	2.60	850	3.05	910	3.45	970	3.90	1025	4.35	1075	4.80	1150	5.00	1200	5.60	1250	6.10	1295	8.35
6250	545	1.40	640	1.90	720	2.35	795	2.80	860	3.25	920	3.70	975	4.15	1030	4.60	1080	5.05	1160	5.20	1210	5.80	1260	6.45	1300	8.75
6500	560	1.55	650	2.05	730	2.50	805	3.00	870	3.45	930	3.95	985	4.40	1040	4.85	1090	5.35	1170	5.50	1220	6.10	1270	6.75	1310	9.15
6750	570	1.70	665	2.20	745	2.70	815	3.20	880	3.70	940	4.20	995	4.65	1045	5.10	1095	5.60	1175	5.85	1225	6.45	1275	7.10	1315	9.60
7000	585	1.85	675	2.35	755	2.90	825	3.40	890	3.95	950	4.45	1005	4.95	1055	5.40	1105	5.95	1185	6.10	1235	6.60	1285	7.30	1325	10.05
7250	600	2.00	690	2.60	765	3.10	835	3.65	900	4.15	955	4.65	1015	5.25	1065	5.75	1115	6.25	1200	6.45	1250	7.00	1300	7.85	1340	10.45
7500	615	2.20	700	2.75	775	3.30	845	3.85	910	4.45	965	4.95	1020	5.50	1070	6.05	1120	6.60	1250	6.75	1300	7.30	1350	8.25	1390	10.90
7750	630	2.40	715	3.00	790	3.55	855	4.10	920	4.70	975	5.25	1030	5.80	1080	6.35	1130	6.90	1280	7.00	1330	7.60	1380	8.60	1420	11.40
8000	640	2.55	725	3.20	800	3.80	865	4.35	930	4.95	985	5.50	1040	6.10	1090	6.70	1140	7.25	1300	7.25	1350	7.85	1400	9.00	1440	11.80
8250	655	2.80	740	3.40	810	4.00	880	4.65	940	5.25	995	5.85	1050	6.45	1100	7.05	1150	7.65	1320	7.50	1370	8.10	1420	9.30	1460	12.20
8500	670	3.00	750	3.65	825	4.30	890	4.90	950	5.55	1005	6.15	1060	6.80	1110	7.40	1160	8.05	1340	7.75	1390	8.35	1440	9.60	1480	12.60
8750	685	3.25	765	3.90	835	4.55	900	5.20	960	5.85	1015	6.45	1070	7.15	1120	7.75	1170	8.35	1360	8.00	1410	8.60	1460	9.90	1500	13.00
9000	700	3.50	780	4.20	850	4.85	910	5.50	970	6.15	1025	6.80	1080	7.50	1130	8.15	1180	8.75	1380	8.25	1430	8.85	1480	10.20	1540	13.40
9250	715	3.75	790	4.45	860	5.15	925	5.85	985	6.55	1040	7.20	1090	7.85	1140	8.55	1190	9.20	1400	8.50	1450	9.10	1500	10.50	1560	13.80
9500	730	4.00	805	4.75	875	5.45	935	6.15	995	6.90	1050	7.60	1100	8.25	1150	8.95	1200	9.60	1420	8.75	1470	9.35	1520	10.80	1580	14.20
9750	745	4.30	820	5.05	885	5.75	950	6.55	1005	7.20	1060	7.95	1110	8.65	1160	9.40	1210	10.05	1440	9.00	1490	9.60	1540	11.10	1600	14.60
10,000	760	4.60	835	5.40	900	6.15	960	6.85	1015	7.60	1070	8.35	1120	9.05	1170	9.80	1220	10.50	1460	9.25	1510	9.85	1560	11.40	1620	15.00
10,250	775	4.90	845	5.65	910	6.45	970	7.20	1030	8.00	1080	8.75	1135	9.55	1180	10.25	1235	11.00	1480	9.50	1530	10.10	1580	11.70	1640	15.40
10,500	790	5.20	860	6.00	925	6.85	985	7.65	1040	8.40	1095	9.20	1145	10.10	1190	10.70	1245	11.45	1500	9.75	1550	10.35	1600	12.00	1660	15.80
10,750	805	5.55	875	6.40	940	7.25	1000	8.05	1055	8.85	1105	9.65	1155	10.45	1200	11.20	1255	11.80	1520	10.00	1570	10.60	1620	12.30	1680	16.20
11,000	820	5.90	890	6.80	950	7.60	1010	8.45	1065	9.30	1115	10.05	1165	10.90	1210	11.65	1265	12.15	1540	10.25	1590	10.85	1640	12.60	1700	16.60

BLOWER DATA

FACTORY INSTALLED BELT DRIVE KIT SPECIFICATIONS

Motor Efficiency	Nominal hp	Maximum hp	Drive Kit Number	RPM Range
Standard or High	2	2.30	1	535 - 725
Standard or High	2	2.30	2	710 - 965
Standard	3	3.45	1	535 - 725
Standard	3	3.45	2	710 - 965
Standard	5	5.75	3	685 - 856
Standard	5	5.75	4	850 - 1045
Standard	5	5.75	5	945 - 1185
Standard	7.5	8.63	6	850 - 1045
Standard	7.5	8.63	7	945 - 1185
Standard	7.5	8.63	8	1045 - 1285
Standard	10	11.50	7	945 - 1185
Standard	10	11.50	10	1045 - 1285
Standard	10	11.50	11	1135 - 1365

NOTE - Using total air volume and system static pressure requirements determine from blower performance tables rpm and motor output required. Maximum usable output of motors furnished are shown. In Canada, nominal motor output is also maximum usable motor output. If motors of comparable output are used, be sure to keep within the service factor limitations outlined on the motor nameplate.

FACTORY INSTALLED OPTIONS/FIELD INSTALLED ACCESSORY AIR RESISTANCE - in. w.g.

Air Volume cfm	Wet Indoor Coil		Condenser Reheat Coil	Gas Heat Exchanger			Electric Heat	Economizer	Filters		Horizontal Roof Curb	
	156H, 180H, 180S, 210S	210H, 240S/H, 300S		Standard Heat	Medium Heat	High Heat			MERV 8	MERV 13	180S- 240S 156H- 240H	300S
2750	.01	.02	.01	.02	.04	.05	---	---	.01	.03	.03	---
3000	.01	.02	.01	.03	.04	.05	---	---	.01	.03	.04	---
3250	.01	.03	.01	.03	.05	.06	---	---	.01	.04	.04	.01
3500	.01	.03	.02	.03	.05	.06	---	---	.01	.04	.05	.01
3750	.01	.03	.02	.04	.06	.07	---	---	.01	.04	.05	.01
4000	.02	.04	.02	.04	.06	.07	---	---	.01	.04	.06	.02
4250	.02	.04	.02	.04	.06	.08	---	---	.01	.05	.07	.02
4500	.02	.05	.02	.05	.07	.09	---	---	.01	.05	.07	.02
4750	.02	.05	.02	.05	.08	.10	---	---	.02	.05	.08	.03
5000	.02	.05	.02	.05	.09	.11	---	---	.02	.06	.08	.03
5250	.02	.06	.03	.06	.10	.12	---	---	.02	.06	.09	.04
5500	.02	.07	.03	.06	.10	.13	---	---	.02	.06	.10	.04
5750	.03	.07	.03	.06	.11	.14	---	---	.02	.07	.11	.05
6000	.03	.08	.03	.07	.12	.15	.01	---	.03	.07	.11	.06
6250	.03	.08	.03	.07	.12	.16	.01	.01	.03	.07	.12	.07
6500	.03	.09	.04	.08	.13	.17	.01	.02	.03	.08	.13	.08
6750	.04	.10	.04	.08	.14	.18	.01	.03	.03	.08	.14	.08
7000	.04	.10	.04	.09	.15	.19	.01	.04	.04	.08	.15	.09
7250	.04	.11	.04	.09	.16	.20	.01	.05	.04	.09	.16	.10
7500	.05	.12	.05	.10	.17	.21	.01	.06	.04	.09	.17	.11
8000	.05	.13	.05	.11	.19	.24	.02	.09	.05	.10	.19	.13
8500	.06	.15	.05	.12	.20	.26	.02	.11	.05	.10	.21	.15
9000	.07	.16	.06	.13	.23	.29	.04	.14	.06	.11	.24	.17
9500	.08	.18	.07	.14	.25	.32	.05	.16	.07	.12	.26	.19
10,000	.08	.20	.07	.16	.27	.35	.06	.19	.07	.12	.29	.21
10,500	.09	.22	.08	.17	.30	.38	.09	.22	.08	.13	.31	.24
11,000	.11	.24	.08	.18	.31	.40	.11	.25	.09	.14	.34	.27

**TABLE 3
MANUFACTURER'S NUMBERS**

Drive No.	H.P.	DRIVE COMPONENTS									
		RPM		ADJUSTABLE SHEAVE		FIXED SHEAVE		BELTS		SPLIT BUSHING	
		Min	Max	Supplier No.	OEM Part No.	Supplier No.	OEM Part No.	Supplier No.	OEM Part No.	Supplier No.	OEM Part No.
1	2, 3	535	725	1VP40x7/8	79J0301	BK95X1-3/16	105617-02	BX59	59A5001	N/A	N/A
2	2, 3	710	965	1VP40x7/8	79J0301	BK72x1-3/16	105617-01	BX55	63K0501	N/A	N/A
3	5	685	865	1VP50x1-1/8	P-8-1977	BK100x1-3/16	105617-03	BX61	93J9801	N/A	N/A
4	5	850	1045	1VP65x1-1/8	100239-03	BK110H	100788-06	BX65	100245-08	H-1-3/16	105616-02
5	5	945	1185	1VP60x1-1/8	41C1301	BK90H	100788-04	BX72	57A7701	H-1-3/16	105616-02
6	7.5	850	1045	1VP65x1-3/8	78M7101	BK110H	100788-06	BX66	97J5901	H-1-3/16	105616-02
7	7.5, 10	945	1185	1VP60x1-3/8	78L5501	BK90H	100788-04	BX63	97J5501	H-1-3/16	105616-02
8	7.5	1045	1285	1VP65x1-3/8	78M7101	BK90H	100788-04	BX64	97J5801	H-1-3/16	105616-02
10	10	1045	1285	1VP65x1-3/8	78M7101	1B5V86	78M8301	5VX670	100245-21	B-1-3/16	105616-01
11	10	1135	1365	1VP65x1-3/8	78M7101	1B5V80	100240-05	5VX660	100245-20	B-1-3/16	105616-01

Cooling Start-Up

IMPORTANT-The crankcase heater must be energized for 24 hours before attempting to start compressor. Set thermostat so there is no demand to prevent compressors from cycling. Apply power to unit.

NOTE - These units must not be used as a "construction heater" at any time during any phase of construction. Very low return air temperatures, harmful vapors and misplacement of the filters will damage the unit and its efficiency. Additionally, a unit which will be subject to cold temperatures when not in operation must have a vapor barrier installed to seal the duct connections. Failure to protect the unit from moisture laden air or harmful vapors (generated from the construction process and temporary combustion heating equipment) will cause corrosive condensation within the unit. Failure to properly protect the unit in this situation will cause electrical and electronic component failure and could affect the unit warranty status.

A-Operation

Supply Air Inverter Units - Refer to the Inverter Start-Up section.

- 1- Remove coil covers before starting unit.
- 2- Initiate first and second stage cooling demands according to instructions provided with thermostat.
- 3- Compressor Operation

156H, 180S/H, 210S/H, 240S, Units -

First-stage thermostat demand will energize compressors 1 & 2; a second-stage thermostat demand will energize compressor 3.

240H, 300S Units -

First-stage thermostat demand will energize compressors 1 & 2. Second-stage thermostat demand will energize compressors 3 & 4.

On units with an economizer, when outdoor air is acceptable, a first-stage demand will energize the economizer; a second-stage demand will energize compressors 1 and 2.

4- Refrigerant Circuits

156H, 180S/H, 210S/H, 240S, Units-

Units contain three refrigerant circuits or systems. Evaporator and condenser coil refrigerant circuits 1 and 2 make up stage 1 cooling. Evaporator and condenser refrigerant circuit 3 makes up stage 2 cooling. See figure 12 for 156H, 180S, and 210S units. See figure 13 for 180H, 210H, and 240S units.

240H & 300S units-

Units contain four refrigerant circuits or systems. Evaporator and condenser coil refrigerant circuits 1 and 2 make up stage 1 cooling. Evaporator and condenser refrigerant circuits 3 and 4 make up stage 2 cooling. See figure 14.

156H, 180S, 210S UNITS - THREE REFRIGERANT CIRCUITS

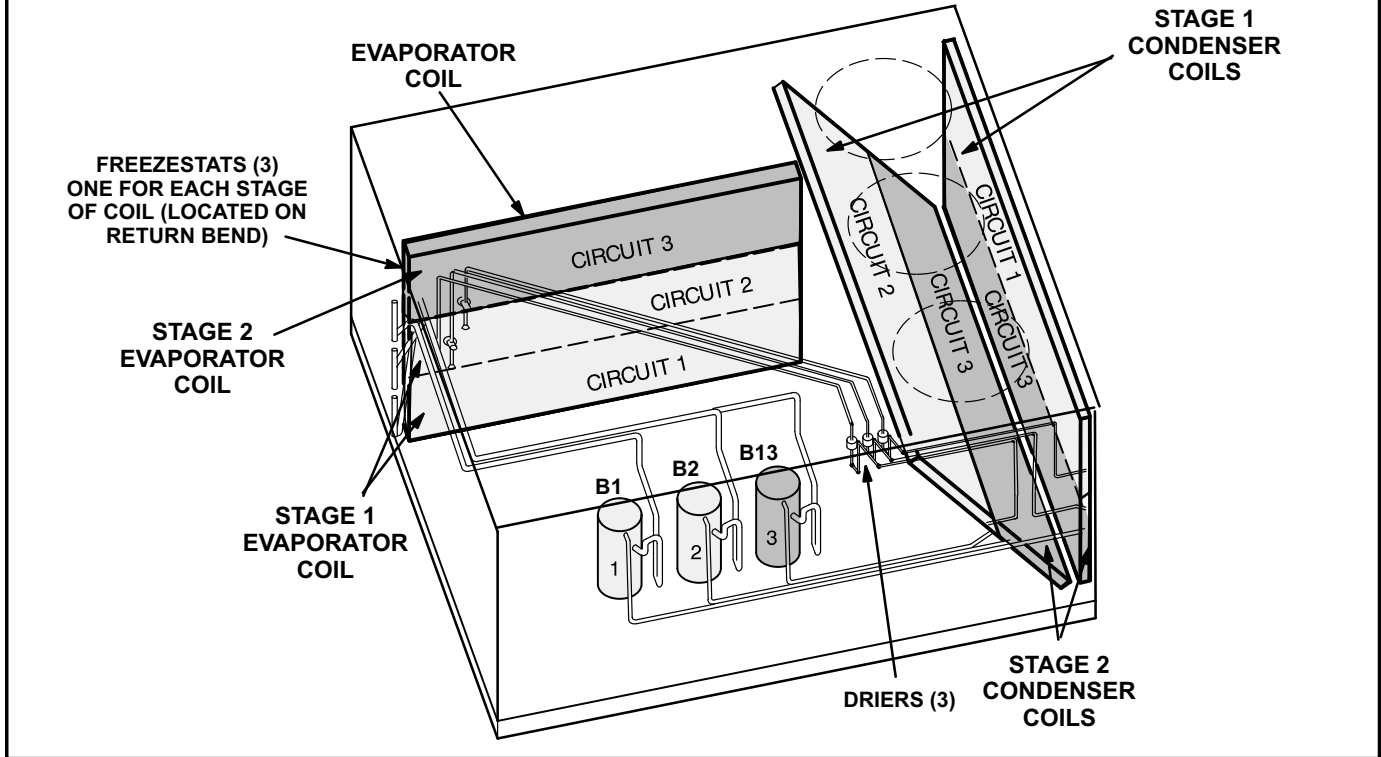


FIGURE 12

180H, 210H, 240S - THREE REFRIGERANT CIRCUITS

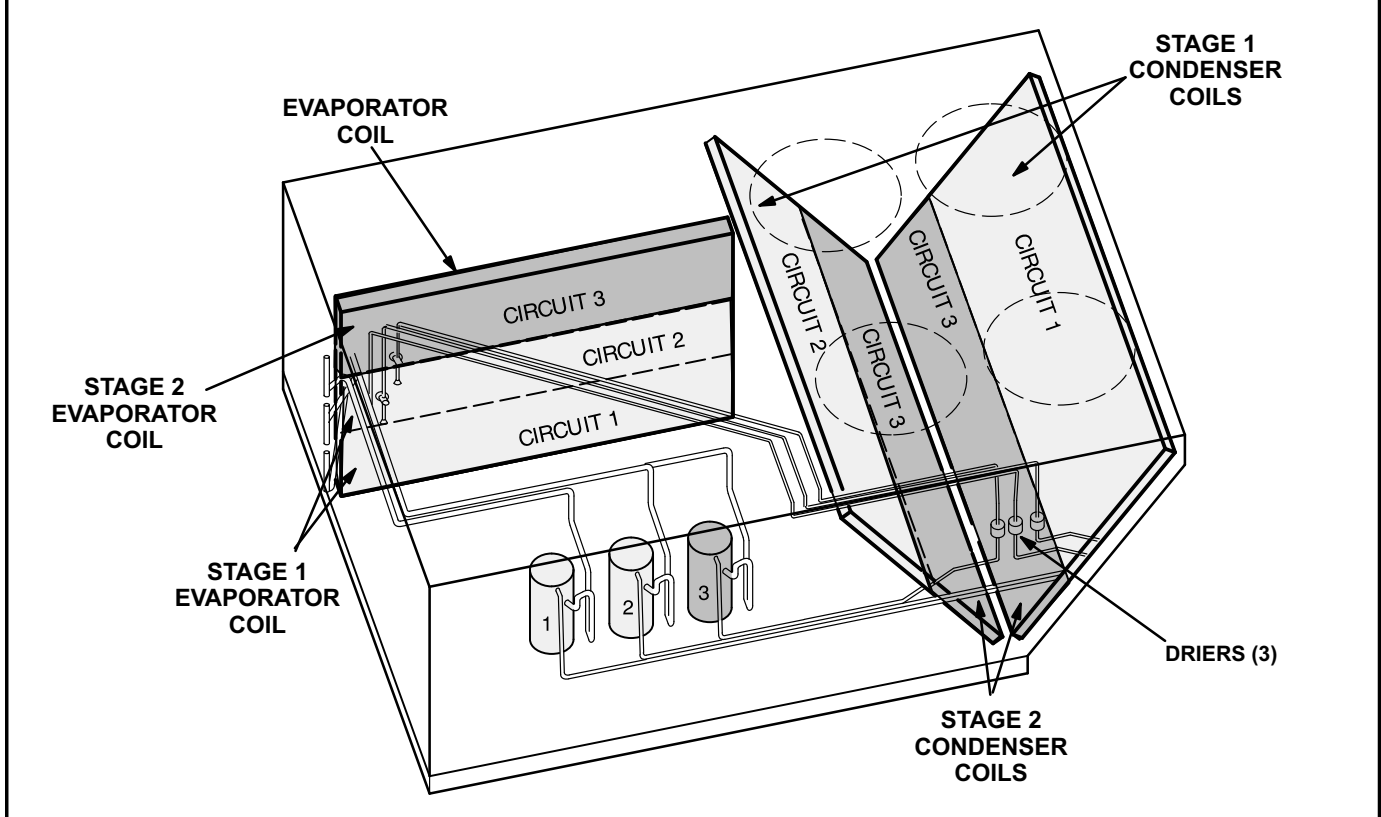


FIGURE 13

240H & 300S REFRIGERANT CIRCUITS

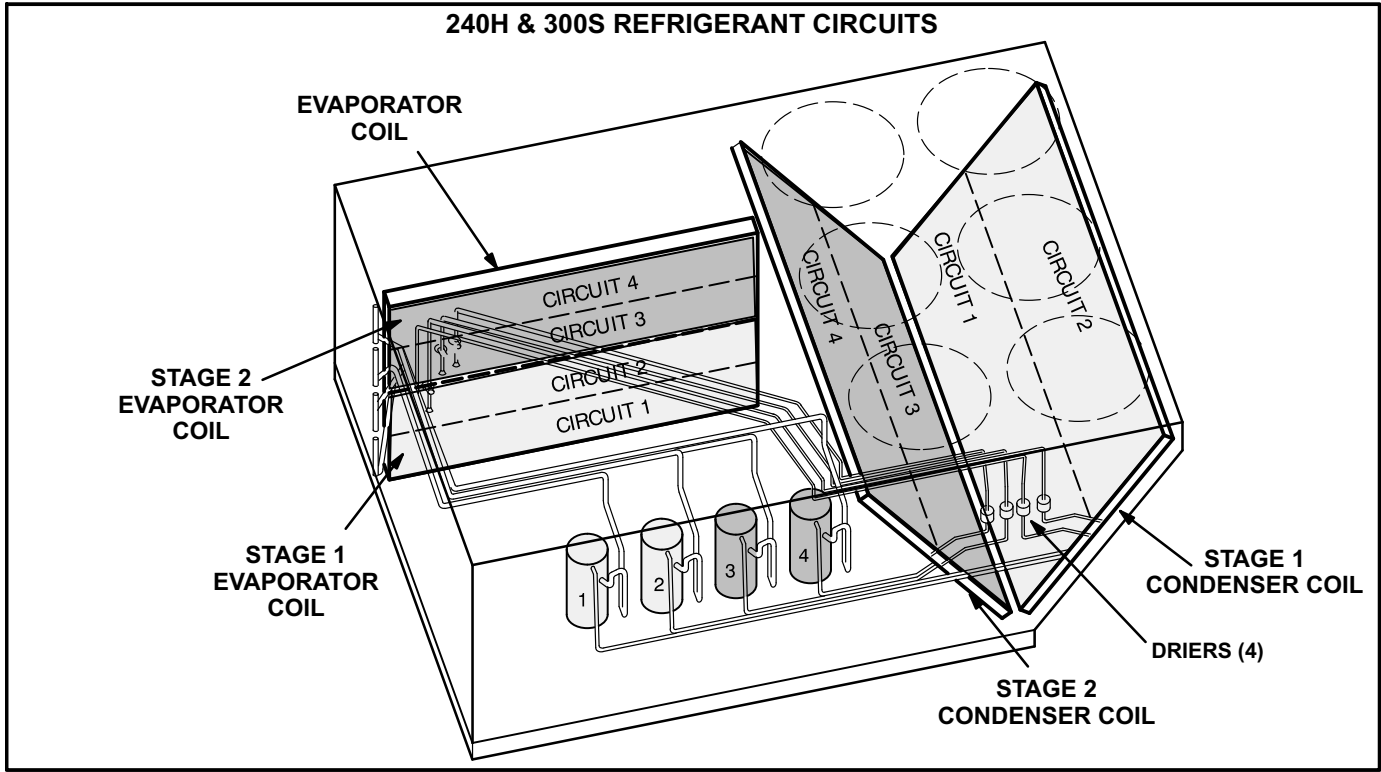


FIGURE 14

5- Condenser Fan Operation

156H, 180S, 210S -

First-stage thermostat demand will energize condenser fans 1, 2 and 3. Fans will continue to operate with additional thermostat demands. See figure 15.

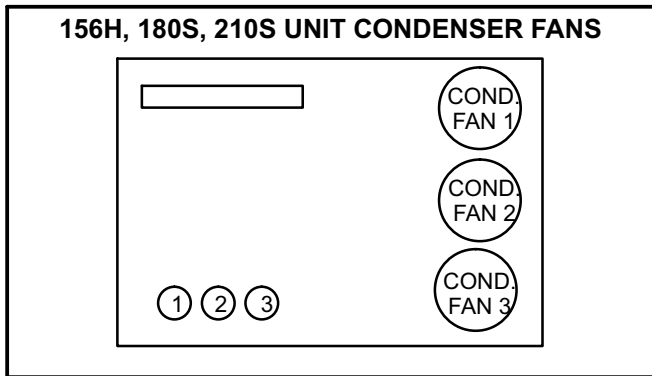


FIGURE 15

180H, 240S-

First-stage thermostat demand will energize condenser fans 1, 2, 3 and 4. See figure 16. Fans will continue to operate with additional thermostat demands.

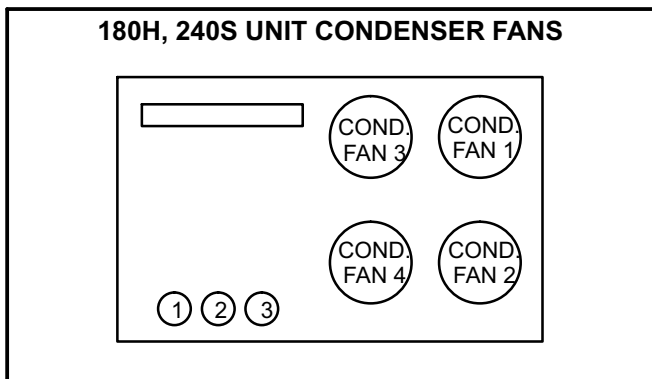


FIGURE 16

210H-

First-stage thermostat demand will energize condenser fans 1, 2, 3, 4, 5 and 6. See figure 17. Fans will continue to operate with additional thermostat demands.

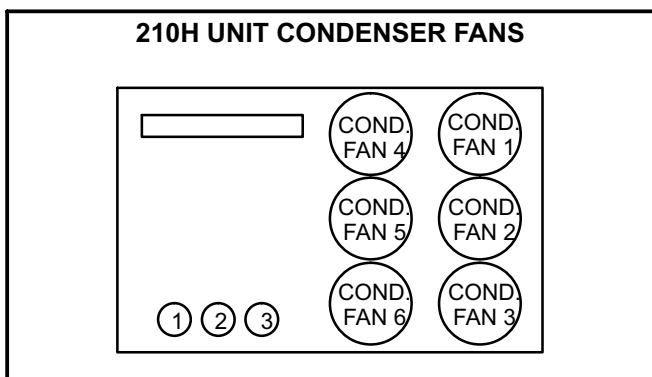


FIGURE 17

240H, 300S-

First-stage thermostat demand will energize condenser fans 1, 2 and 3. Second-stage cooling demand will energize condenser fans 4, 5 and 6. See figure 18.

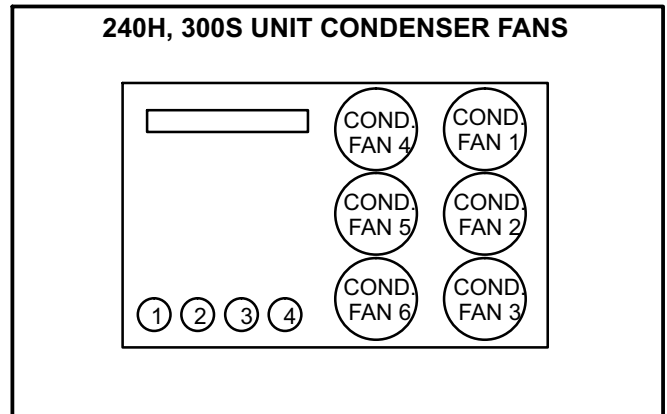


FIGURE 18

6- Each refrigerant circuit is separately charged with R-410A refrigerant. See unit rating plate for correct amount of charge.

7- Refer to Cooling Operation and Adjustment section for proper method to check refrigerant charge.

B-R410A Refrigerant

Units charged with R410A refrigerant operate at much higher pressures than R22. The expansion valve and liquid line drier provided with the unit are approved for use with R410A. Do not replace them with components designed for use with R22.

R410A refrigerant is stored in a pink cylinder.

⚠ IMPORTANT

Mineral oils are not compatible with R410A. If oil must be added, it must be a polyol ester oil.

Manifold gauge sets used with systems charged with R410A refrigerant must be capable of handling the higher system operating pressures. The gauges should be rated for use with pressures of 0-800 on the high side and a low side of 30" vacuum to 250 psi with dampened speed to 500 psi. Gauge hoses must be rated for use at up to 800 psi of pressure with a 4000 psi burst rating.

C-Refrigerant Charge and Check - All-Aluminum Coils

WARNING-Do not exceed nameplate charge under any condition.

This unit is factory charged and should require no further adjustment. If the system requires additional refrigerant, reclaim the charge, evacuate the system, and add required nameplate charge.

*NOTE - System charging is not recommended below 60°F (15°C). In temperatures below 60°F (15°C), the charge **must** be weighed into the system.*

If weighing facilities are not available, or to check the charge, use the following procedure:

IMPORTANT - Charge unit in standard cooling mode.

- 1- Make sure outdoor coil is clean. Attach gauge manifolds and operate unit at full CFM in cooling mode with economizer disabled until system stabilizes (approximately five minutes). Make sure all outdoor air dampers are closed.
- 2- Check each system separately with all stages operating. Compare the normal operating pressures (see tables 4 -11) to the pressures obtained from the gauges. Check unit components if there are significant differences.
- 3- Measure the outdoor ambient temperature and the suction pressure. Refer to the appropriate circuit

charging curve to determine a target liquid temperature.

Note - Pressures are listed for sea level applications.

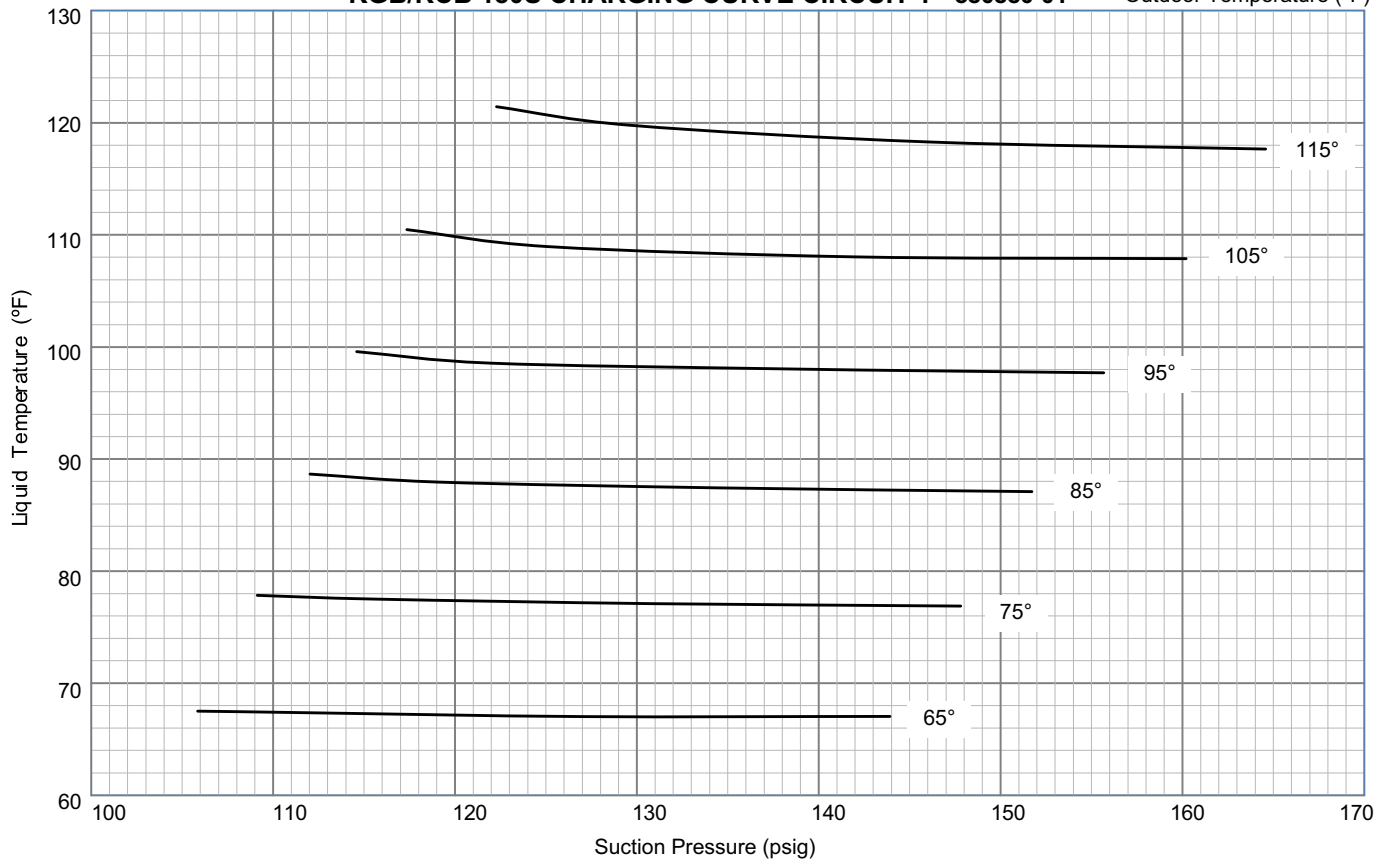
- 4- Use the same thermometer to accurately measure the liquid temperature (in the outdoor section).
 - If measured liquid temperature is higher than the target liquid temperature, add refrigerant to the system.
 - If measured liquid temperature is lower than the target liquid temperature, recover some refrigerant from the system.
- 5- Add or remove charge in increments. Allow the system to stabilize each time refrigerant is added or removed.
- 6- Continue the process until measured liquid temperature agrees with the target liquid temperature. Do not go below the target liquid temperature when adjusting charge. Note that suction pressure can change as charge is adjusted.
- 7- Example KG/KC 180S units, Circuit 1: At 95°F outdoor ambient and a measured suction pressure of 130psig, the target liquid temperature is 98°F. For a measured liquid temperature of 106°F, add charge in increments until measured liquid temperature agrees with the target liquid temperature.

**TABLE 4
KGB/KCB 180S ALL-ALUMINUM COIL NORMAL OPERATING PRESSURES - 580881-01**

Normal Operating Pressures												
	Outdoor Coil Entering Air Temperature											
	65 °F		75 °F		85 °F		95 °F		105 °F		115 °F	
	Suct (psig)	Disc (psig)	Suct (psig)	Disc (psig)	Suct (psig)	Disc (psig)	Suct (psig)	Disc (psig)	Suct (psig)	Disc (psig)	Suct (psig)	Disc (psig)
Circuit 1	106	249	109	286	112	328	115	373	117	422	122	477
	112	256	116	292	119	333	122	378	125	429	130	484
	127	275	131	311	134	352	138	398	142	447	146	505
	144	299	148	336	152	376	156	424	160	478	165	535
Circuit 2	106	251	108	288	111	330	114	372	116	421	118	477
	113	258	116	294	119	334	121	379	124	429	125	484
	127	273	131	311	134	350	138	397	141	445	145	501
	143	296	148	333	152	375	156	421	160	473	164	528
Circuit 3	110	266	113	306	115	348	118	394	120	442	125	497
	117	274	120	311	123	356	126	403	129	454	132	508
	132	292	136	333	139	376	143	424	146	475	149	540
	148	314	153	355	157	401	161	450	165	505	168	568

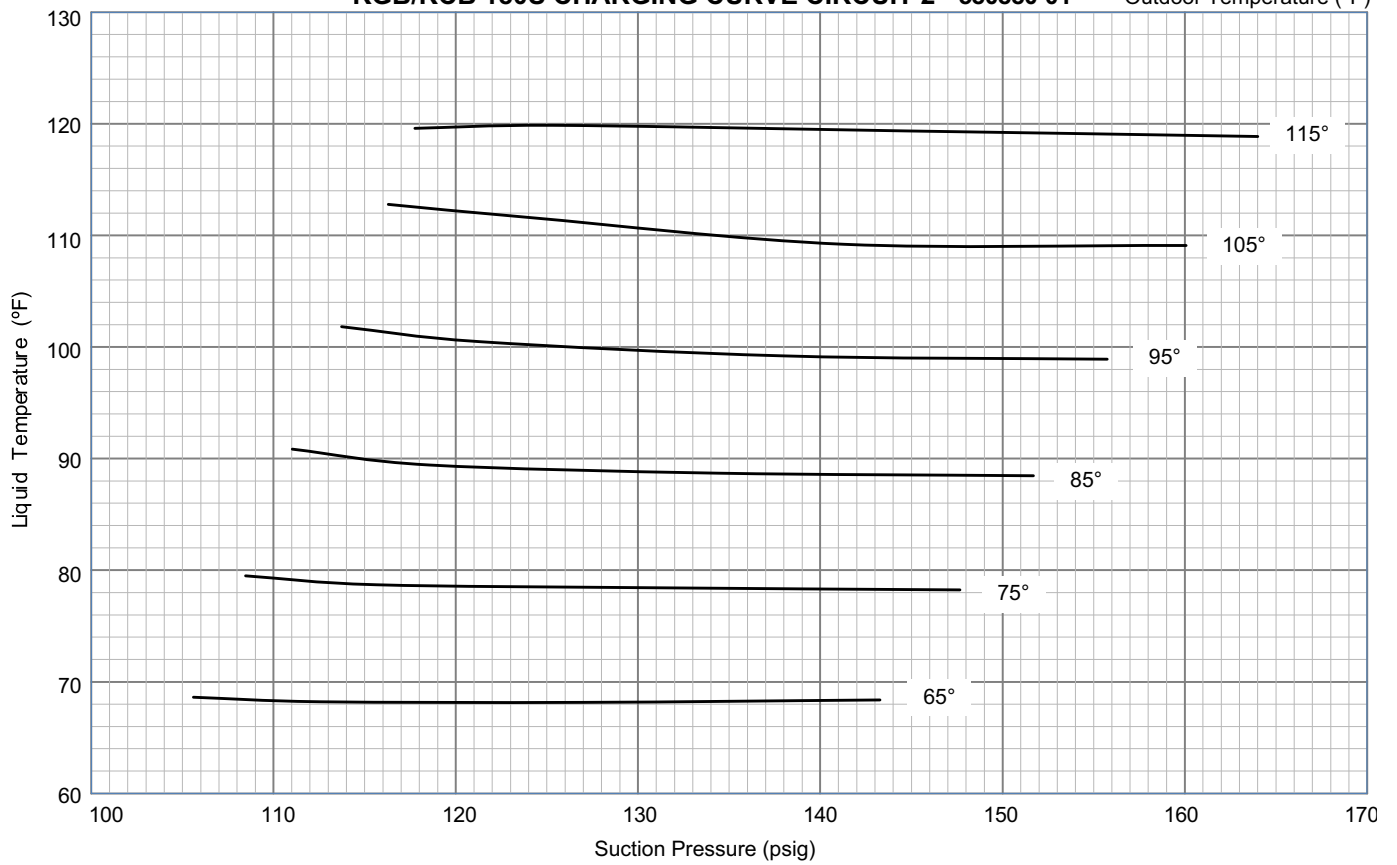
KGB/KCB 180S CHARGING CURVE CIRCUIT 1 - 580880-01

Outdoor Temperature (°F)



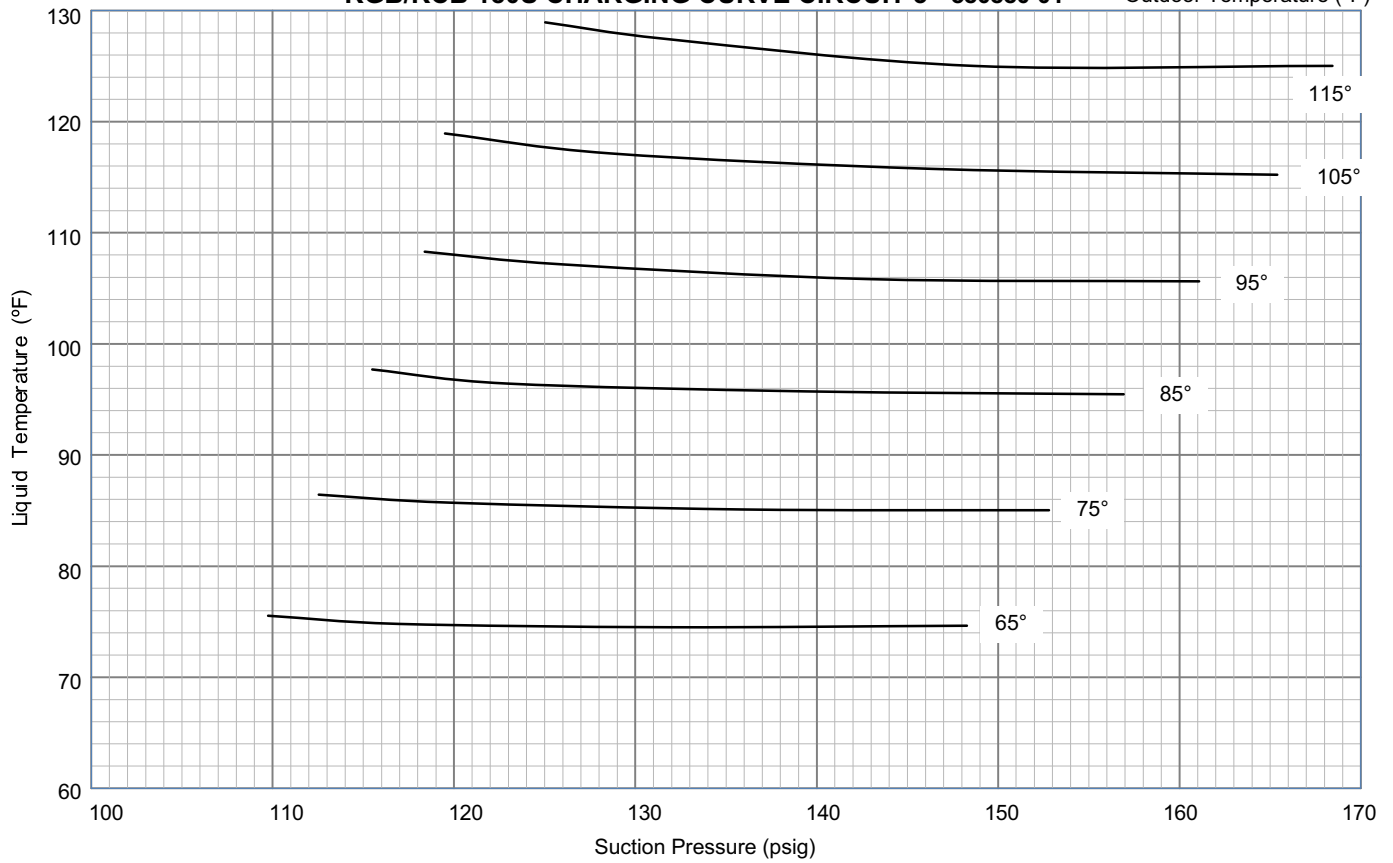
KGB/KCB 180S CHARGING CURVE CIRCUIT 2 - 580880-01

Outdoor Temperature (°F)



KGB/KCB 180S CHARGING CURVE CIRCUIT 3 - 580880-01

Outdoor Temperature (°F)

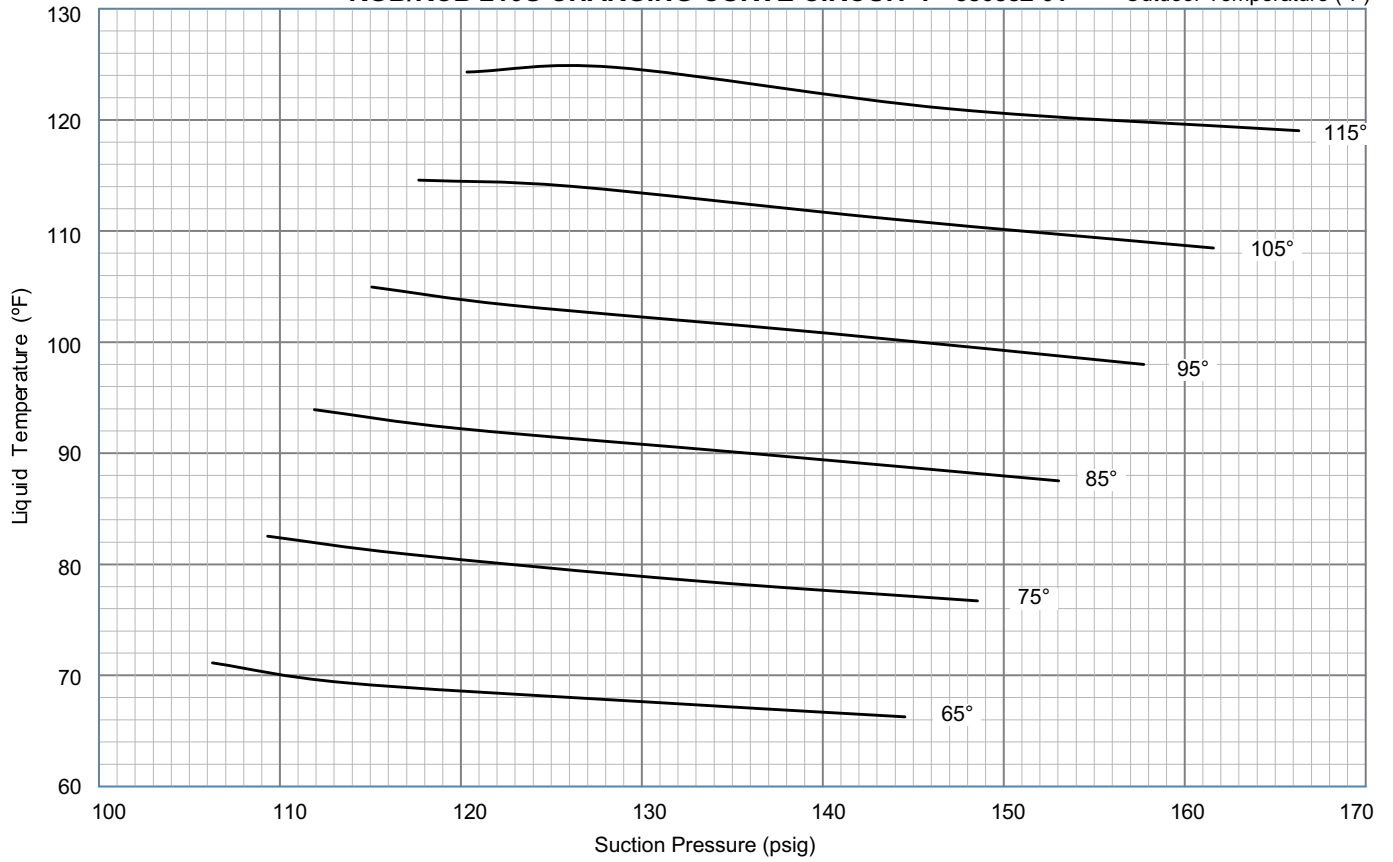


**TABLE 5
KGB/KCB 210S ALL-ALUMINUM OD COIL, NORMAL OPERATING PRESSURES - 580883-01**

Normal Operating Pressures												
	Outdoor Coil Entering Air Temperature											
	65 °F		75 °F		85 °F		95 °F		105 °F		115 °F	
	Suct (psig)	Disc (psig)	Suct (psig)	Disc (psig)	Suct (psig)	Disc (psig)	Suct (psig)	Disc (psig)	Suct (psig)	Disc (psig)	Suct (psig)	Disc (psig)
Circuit 1	106	253	109	291	112	333	115	380	118	427	120	481
	114	258	117	295	120	338	123	385	126	435	129	487
	129	272	133	309	136	351	140	398	144	449	147	506
	145	289	149	324	153	366	158	412	162	462	166	522
Circuit 2	106	262	110	300	113	339	115	384	118	430	120	485
	114	269	117	305	120	346	123	392	126	439	128	495
	130	286	133	322	137	363	141	409	144	457	147	514
	145	303	150	339	154	380	158	425	162	471	166	528
Circuit 3	108	276	111	314	114	356	117	402	119	451	123	503
	115	284	119	322	122	364	125	410	128	462	131	516
	132	304	135	343	139	385	143	433	146	484	149	541
	148	321	152	361	156	403	161	450	164	498	167	557

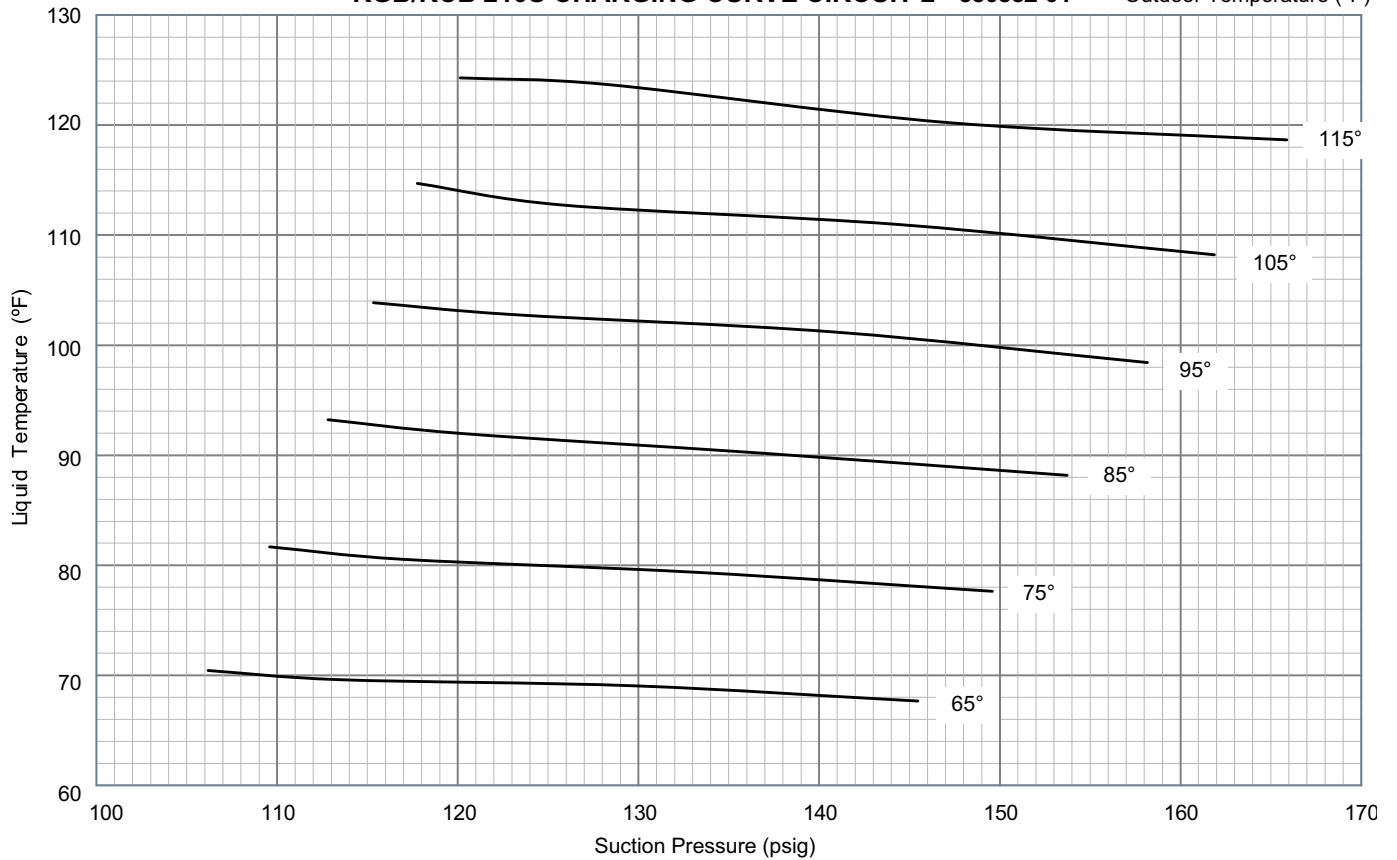
KGB/KCB 210S CHARGING CURVE CIRCUIT 1 - 580882-01

Outdoor Temperature (°F)



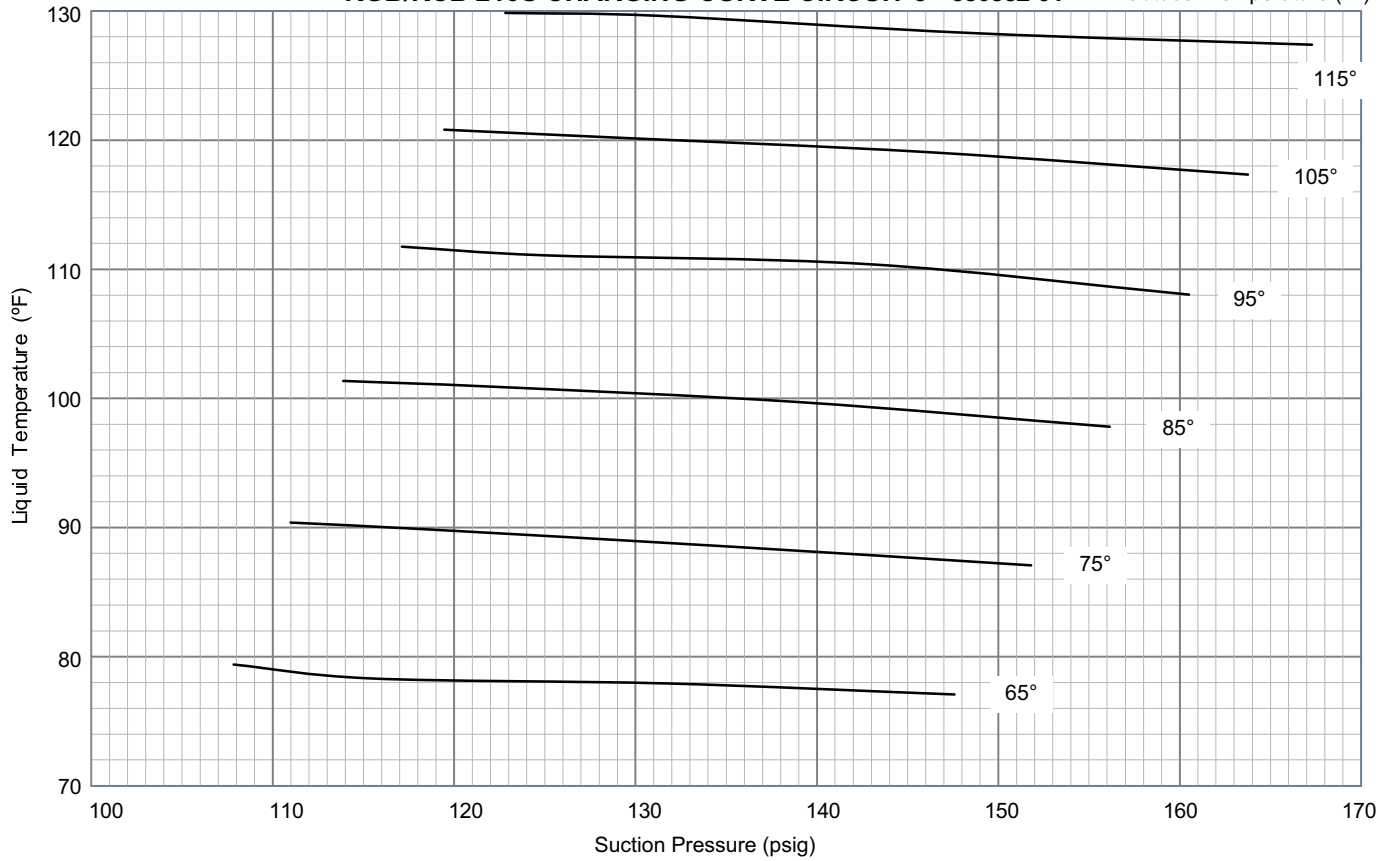
KGB/KCB 210S CHARGING CURVE CIRCUIT 2 - 580882-01

Outdoor Temperature (°F)



KGB/KCB 210S CHARGING CURVE CIRCUIT 3 - 580882-01

Outdoor Temperature (°F)

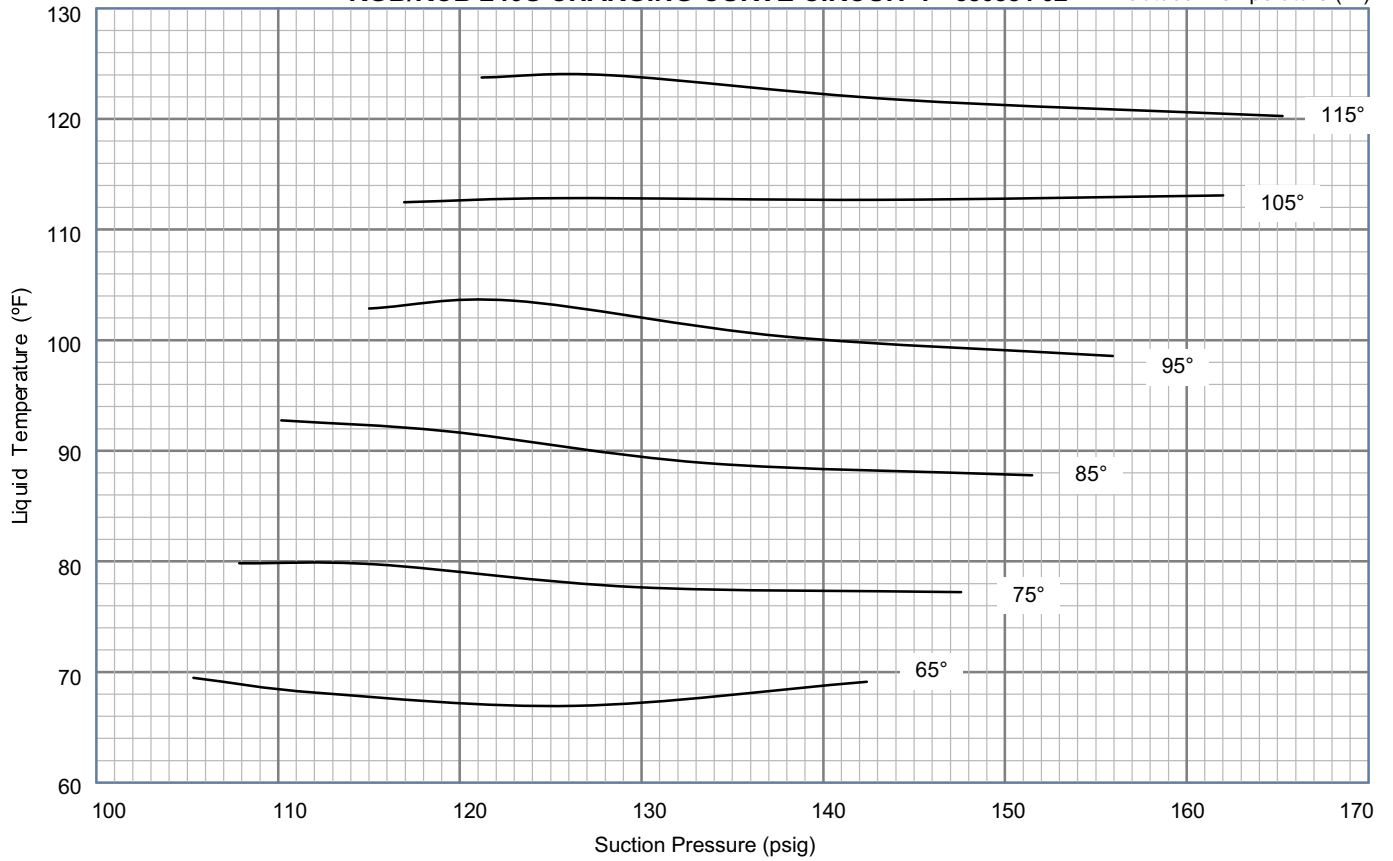


**TABLE 6
KGB/KCB 240S ALL-ALUMINUM OD COIL NORMAL OPERATING PRESSURES - 580885-02**

Normal Operating Pressures												
	Outdoor Coil Entering Air Temperature											
	65 °F		75 °F		85 °F		95 °F		105 °F		115 °F	
	Suct (psig)	Disc (psig)	Suct (psig)	Disc (psig)	Suct (psig)	Disc (psig)	Suct (psig)	Disc (psig)	Suct (psig)	Disc (psig)	Suct (psig)	Disc (psig)
Circuit 1	105	243	108	274	110	321	115	365	117	420	121	472
	112	247	115	284	119	325	123	371	126	424	128	477
	126	259	130	295	134	337	138	384	143	435	144	492
	142	283	148	314	152	354	156	400	162	468	165	506
Circuit 2	107	250	109	282	112	329	115	373	117	431	121	481
	114	255	117	293	120	335	123	380	126	438	129	486
	130	269	133	306	137	348	140	396	144	450	146	501
	147	295	151	327	155	369	159	415	163	483	165	521
Circuit 3	101	267	103	301	106	351	109	397	112	455	116	506
	107	273	110	313	113	357	117	406	121	462	123	515
	122	288	125	329	129	374	132	423	136	479	139	536
	139	314	143	350	146	396	150	445	155	517	158	557

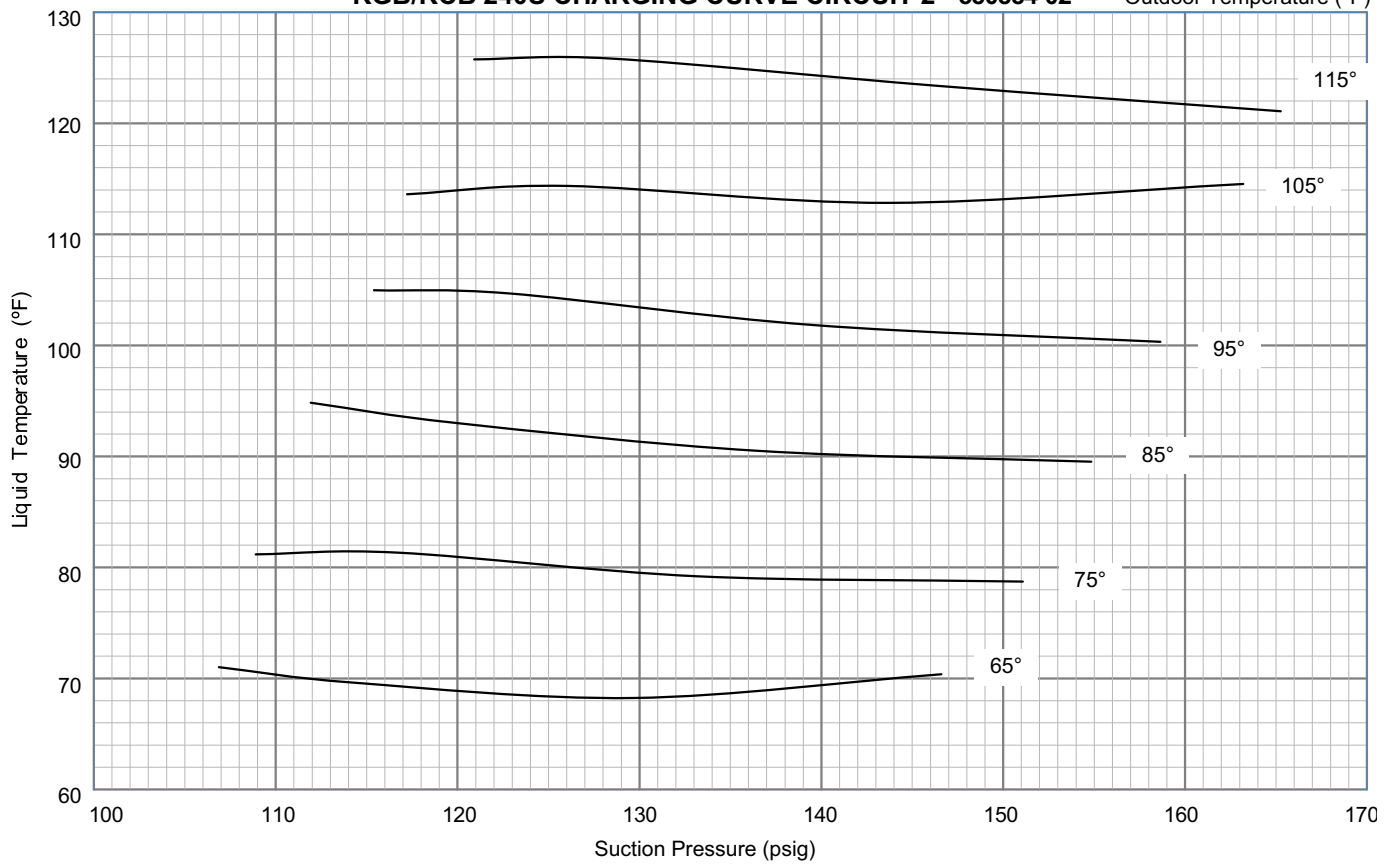
KGB/KCB 240S CHARGING CURVE CIRCUIT 1 - 580884-02

Outdoor Temperature (°F)



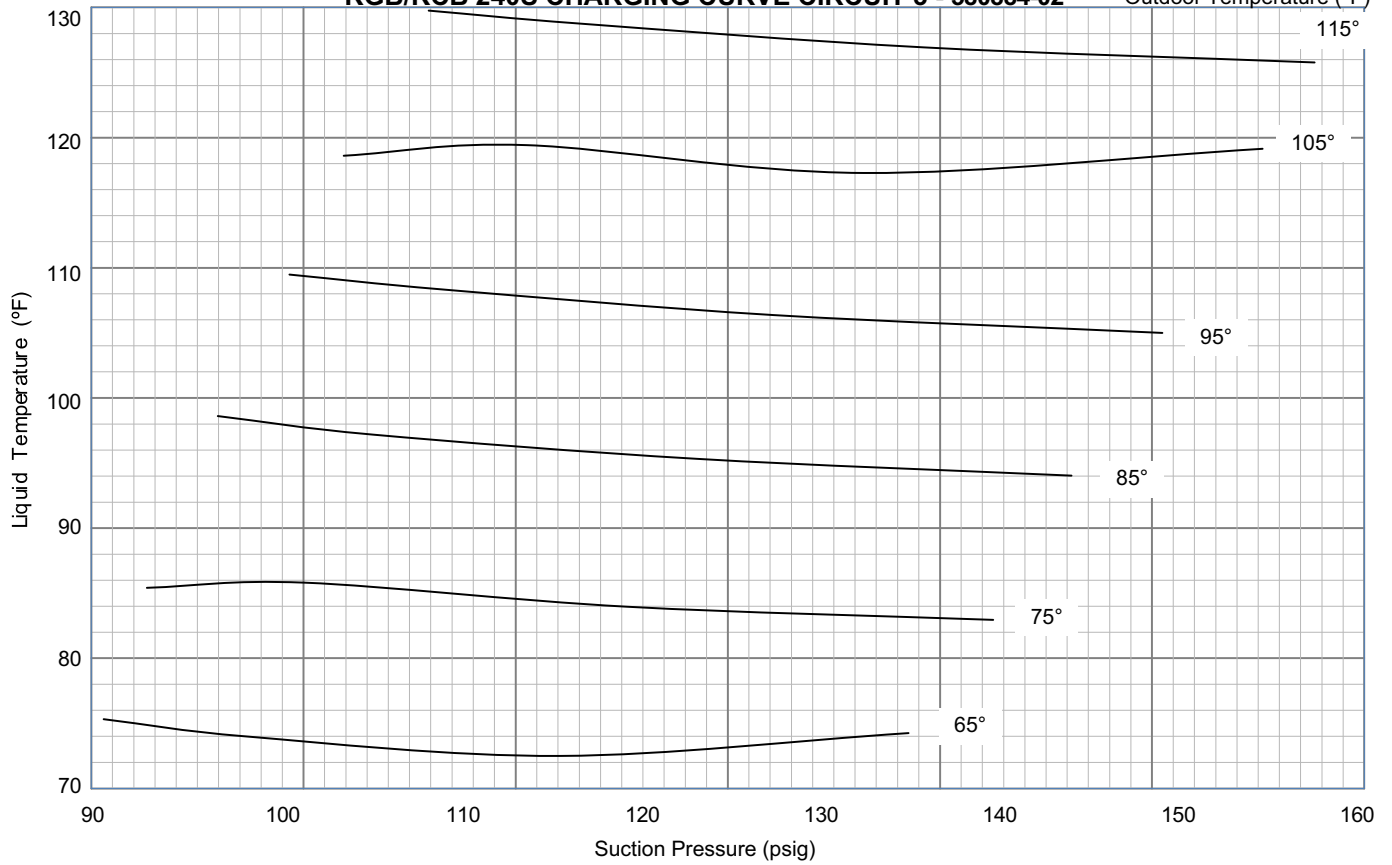
KGB/KCB 240S CHARGING CURVE CIRCUIT 2 - 580884-02

Outdoor Temperature (°F)



KGB/KCB 240S CHARGING CURVE CIRCUIT 3 - 580884-02

Outdoor Temperature (°F)

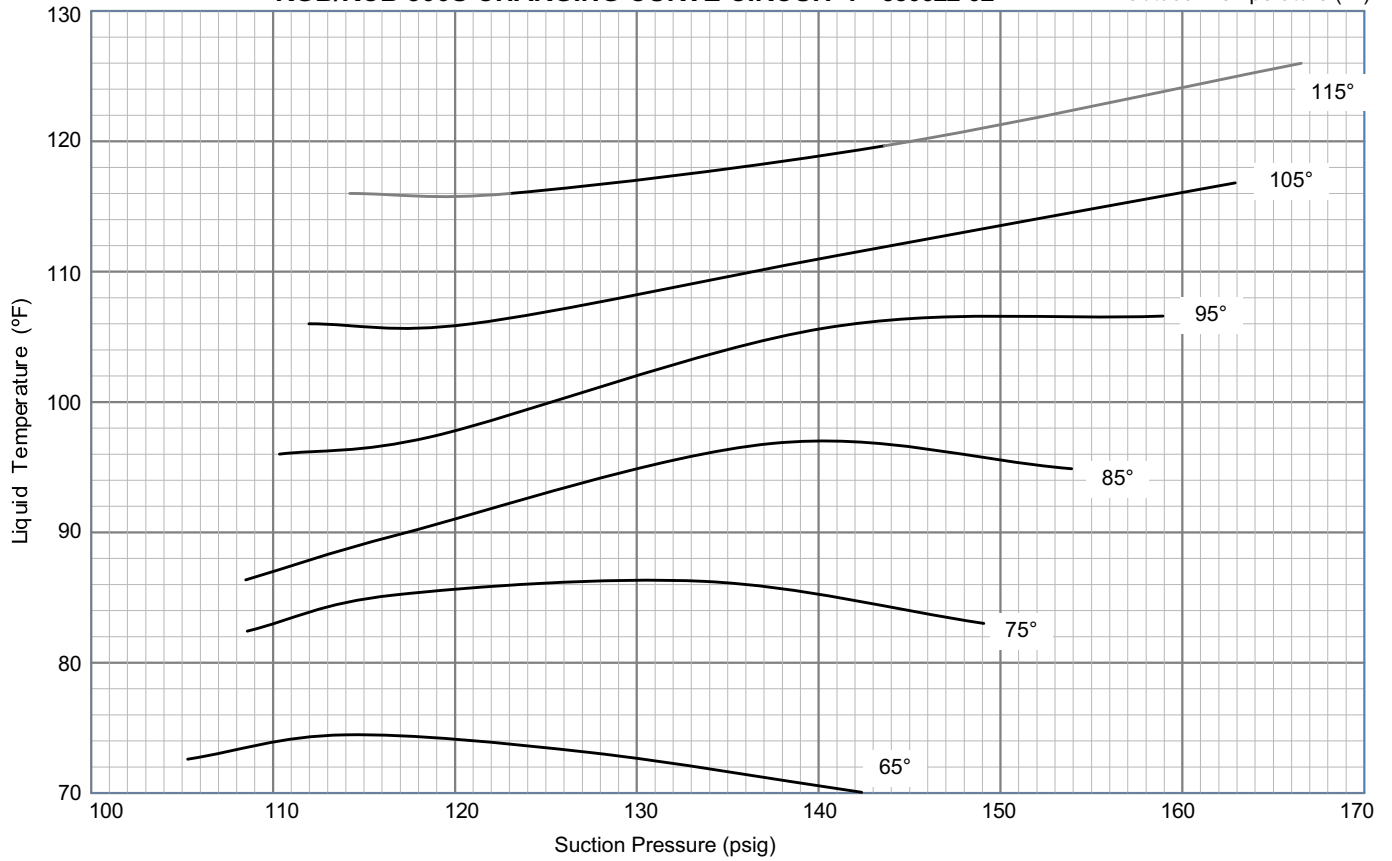


**TABLE 7
KGB/KCB 300S ALL-ALUMINUM OD COIL NORMAL OPERATING PRESSURES - 580623-02**

Normal Operating Pressures												
	Outdoor Coil Entering Air Temperature											
	65 °F		75 °F		85 °F		95 °F		105 °F		115 °F	
	Suct (psig)	Disc (psig)	Suct (psig)	Disc (psig)	Suct (psig)	Disc (psig)	Suct (psig)	Disc (psig)	Suct (psig)	Disc (psig)	Suct (psig)	Disc (psig)
Circuit 1	105	248	109	283	109	330	110	381	112	432	114	486
	114	250	117	291	117	338	119	384	121	432	123	487
	127	253	134	300	137	343	140	388	141	444	144	501
	142	265	149	308	154	349	159	399	163	449	167	503
Circuit 2	103	236	105	272	107	318	108	373	109	428	111	484
	112	238	114	278	116	325	116	374	118	425	120	482
	127	246	131	285	135	327	137	377	140	433	142	491
	141	254	146	294	150	332	156	385	160	437	164	495
Circuit 3	104	258	105	302	107	345	109	399	111	456	114	519
	112	263	114	308	115	354	117	403	120	463	123	524
	131	297	133	320	136	367	138	410	140	465	142	526
	147	313	147	334	152	381	156	423	160	476	165	537
Circuit 4	100	246	103	289	104	329	105	381	107	437	110	500
	109	253	110	293	112	337	114	383	116	443	119	505
	126	281	127	303	131	349	133	391	136	443	139	499
	141	296	143	321	149	370	152	410	157	462	161	521

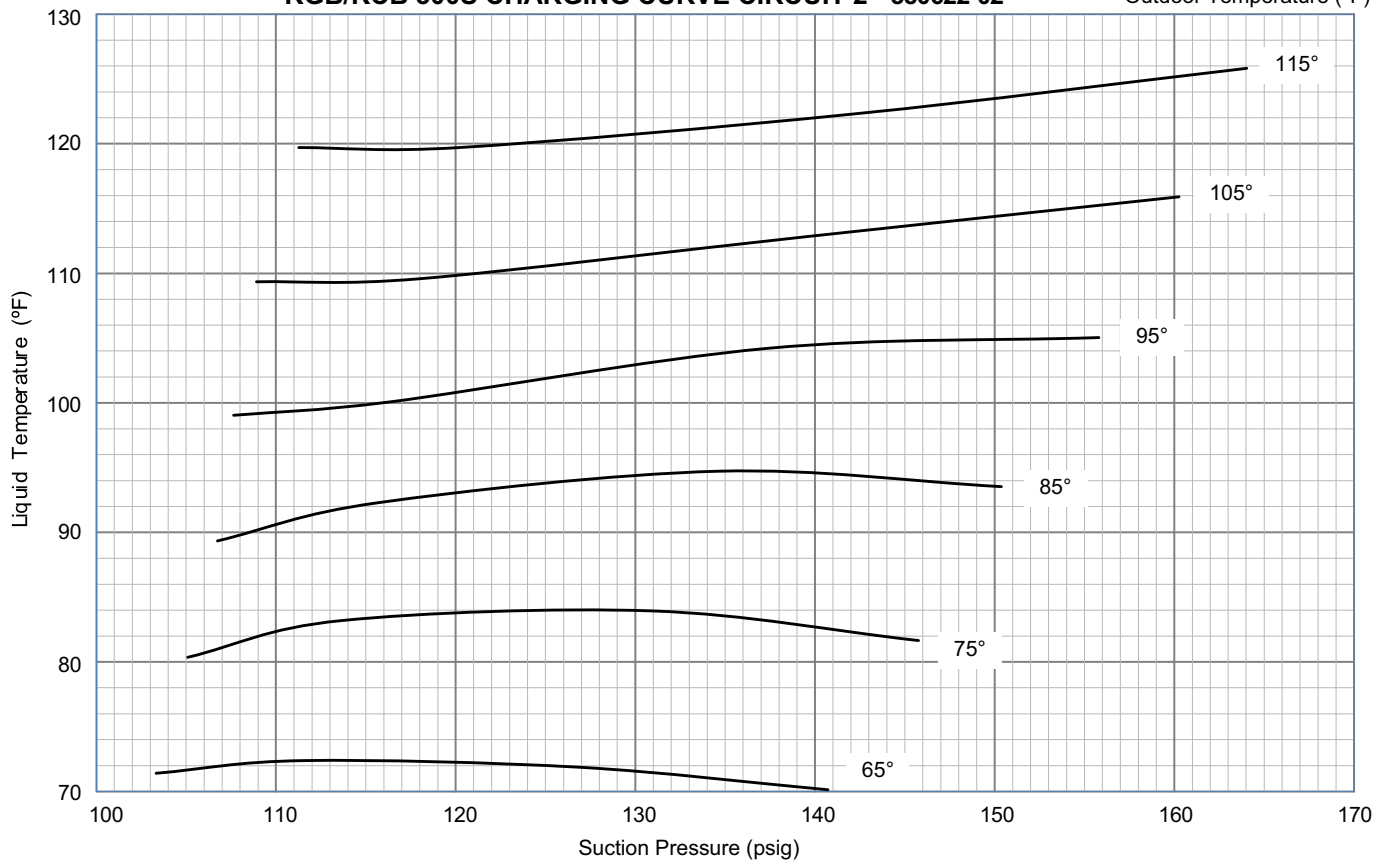
KGB/KCB 300S CHARGING CURVE CIRCUIT 1 - 580622-02

Outdoor Temperature (°F)



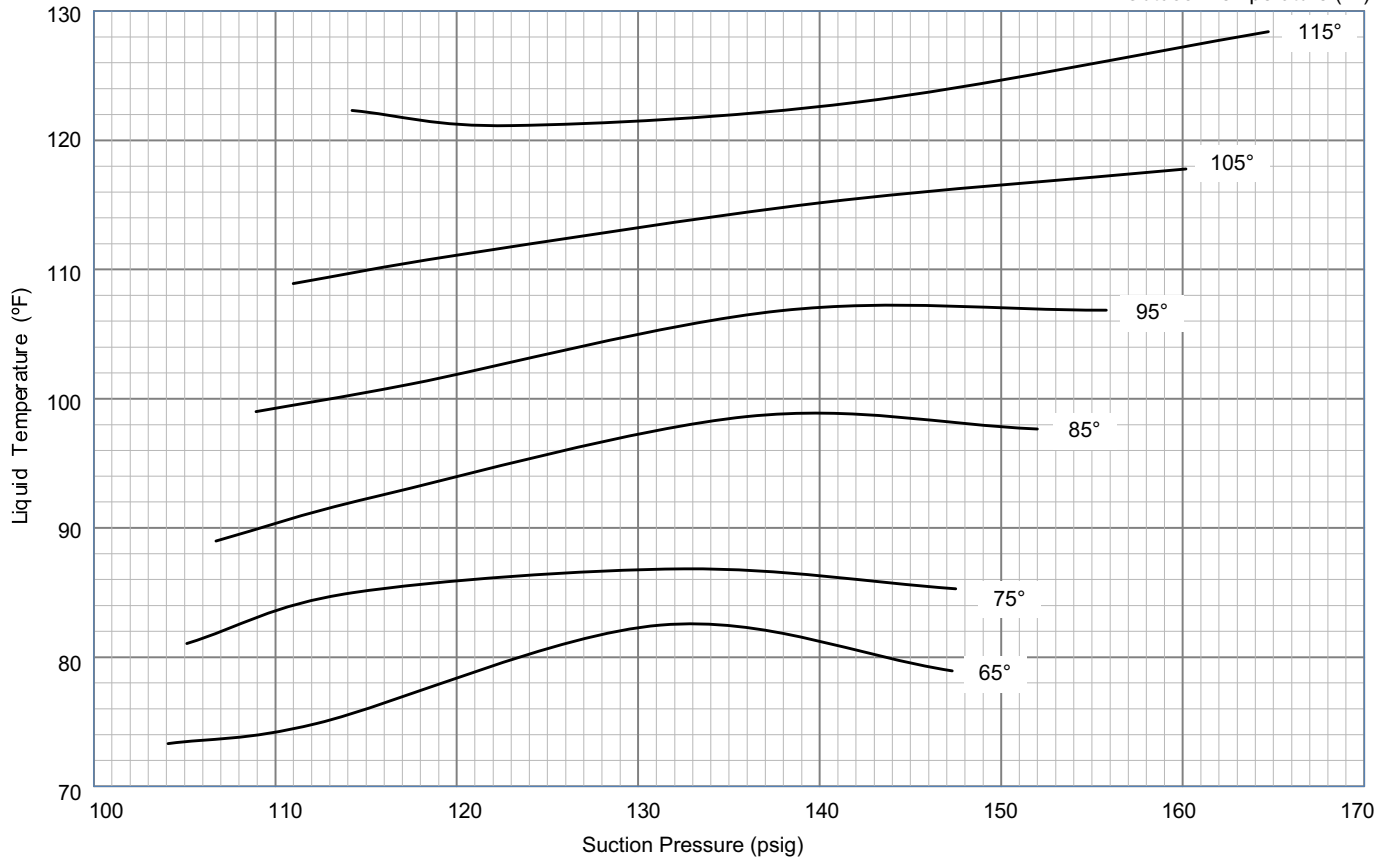
KGB/KCB 300S CHARGING CURVE CIRCUIT 2 - 580622-02

Outdoor Temperature (°F)



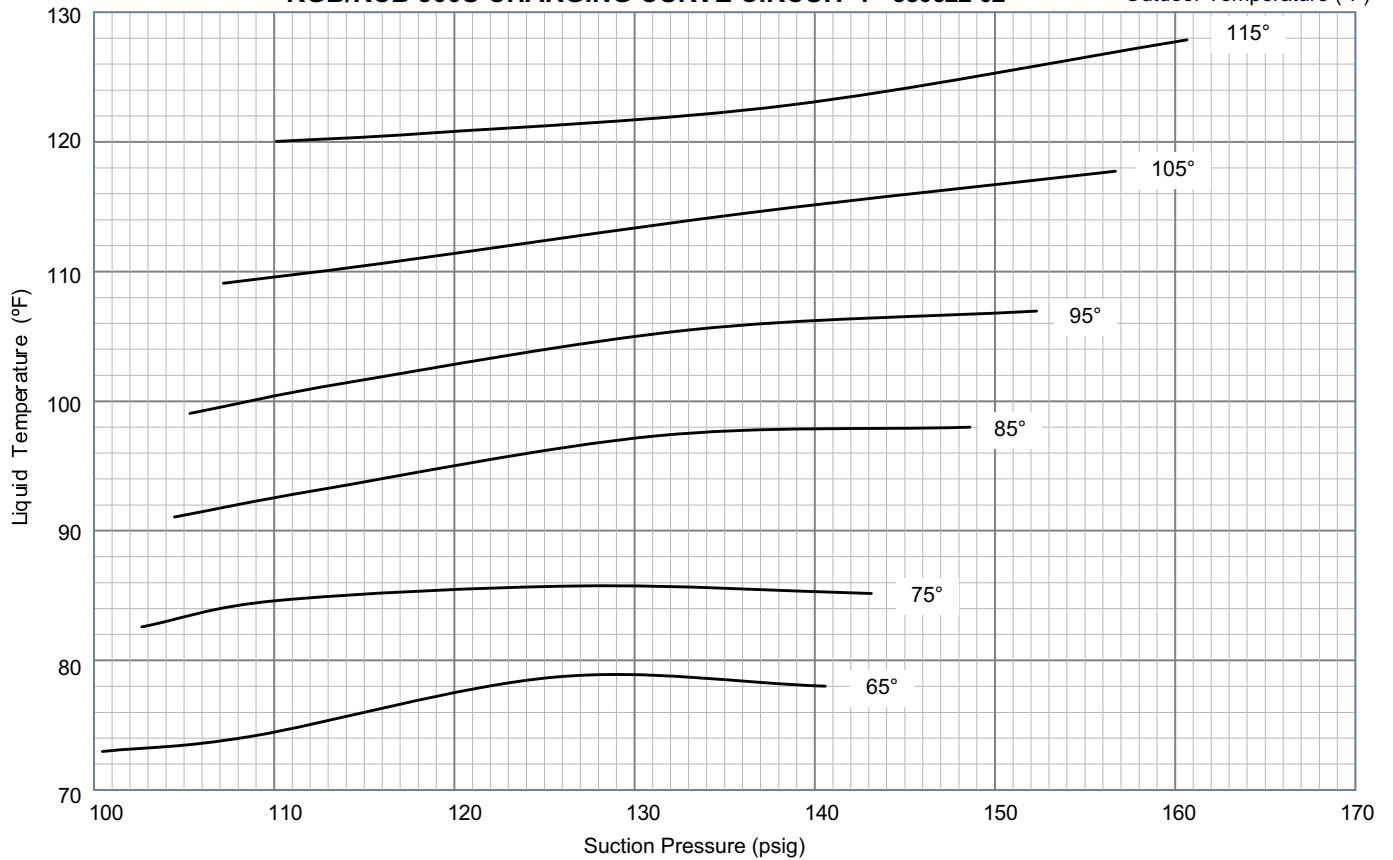
KGB/KCB 300S CHARGING CURVE CIRCUIT 3 - 580622-02

Outdoor Temperature (°F)



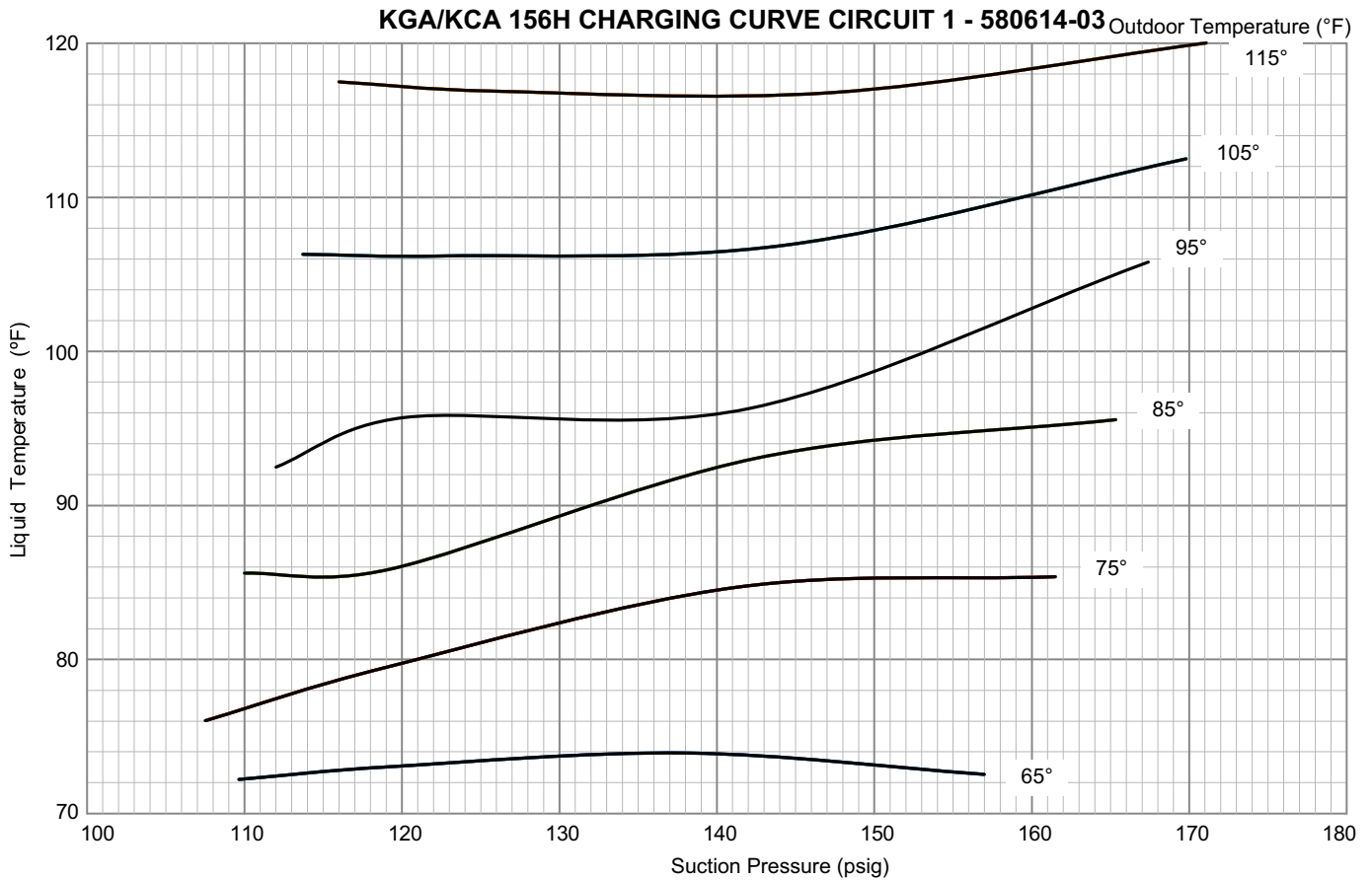
KGB/KCB 300S CHARGING CURVE CIRCUIT 4 - 580622-02

Outdoor Temperature (°F)

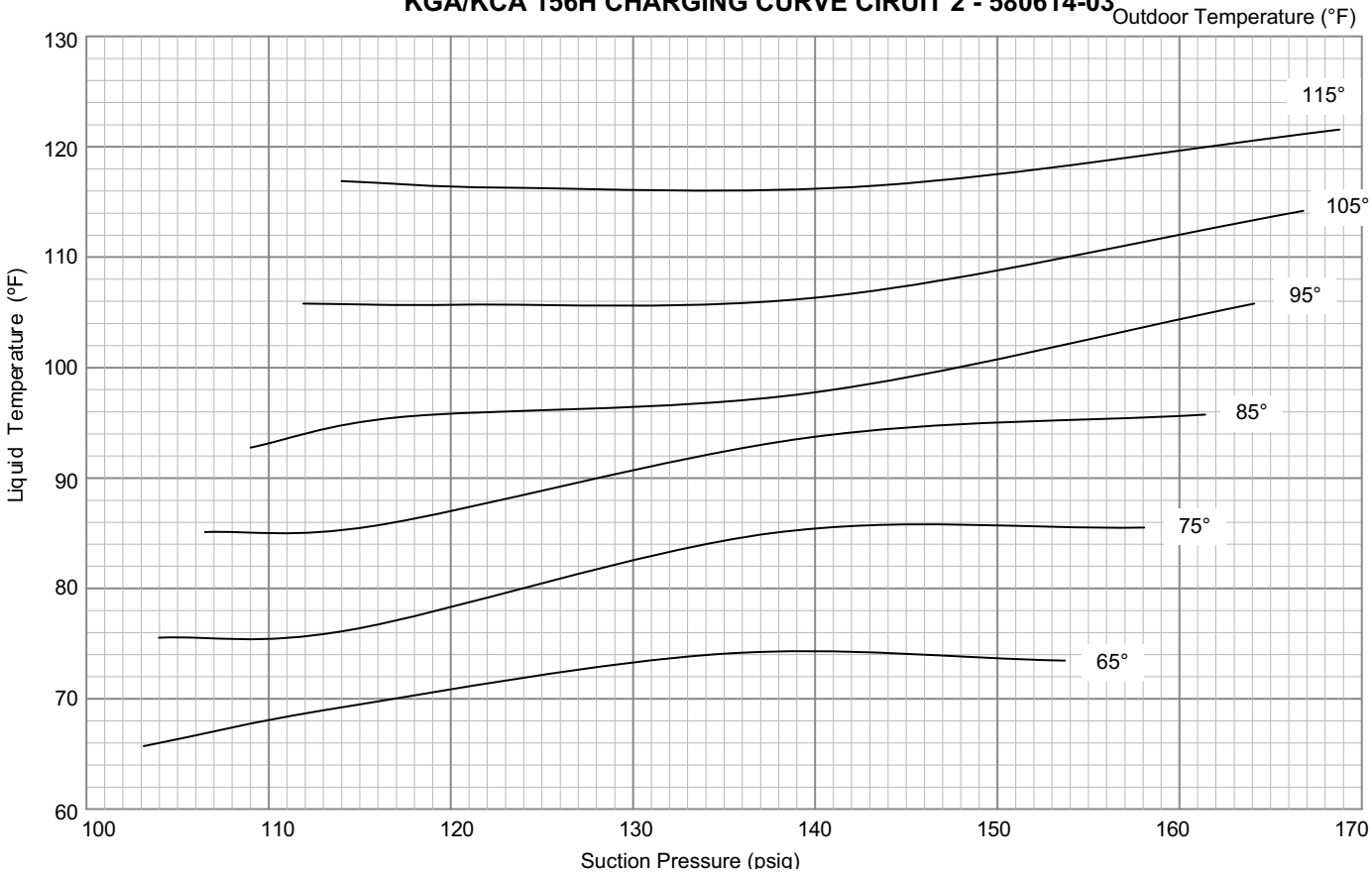


**TABLE 8
KGA/KCA 156H ALL-ALUMINUM OD COIL, NORMAL OPERATING PRESSURES - 580615-03**

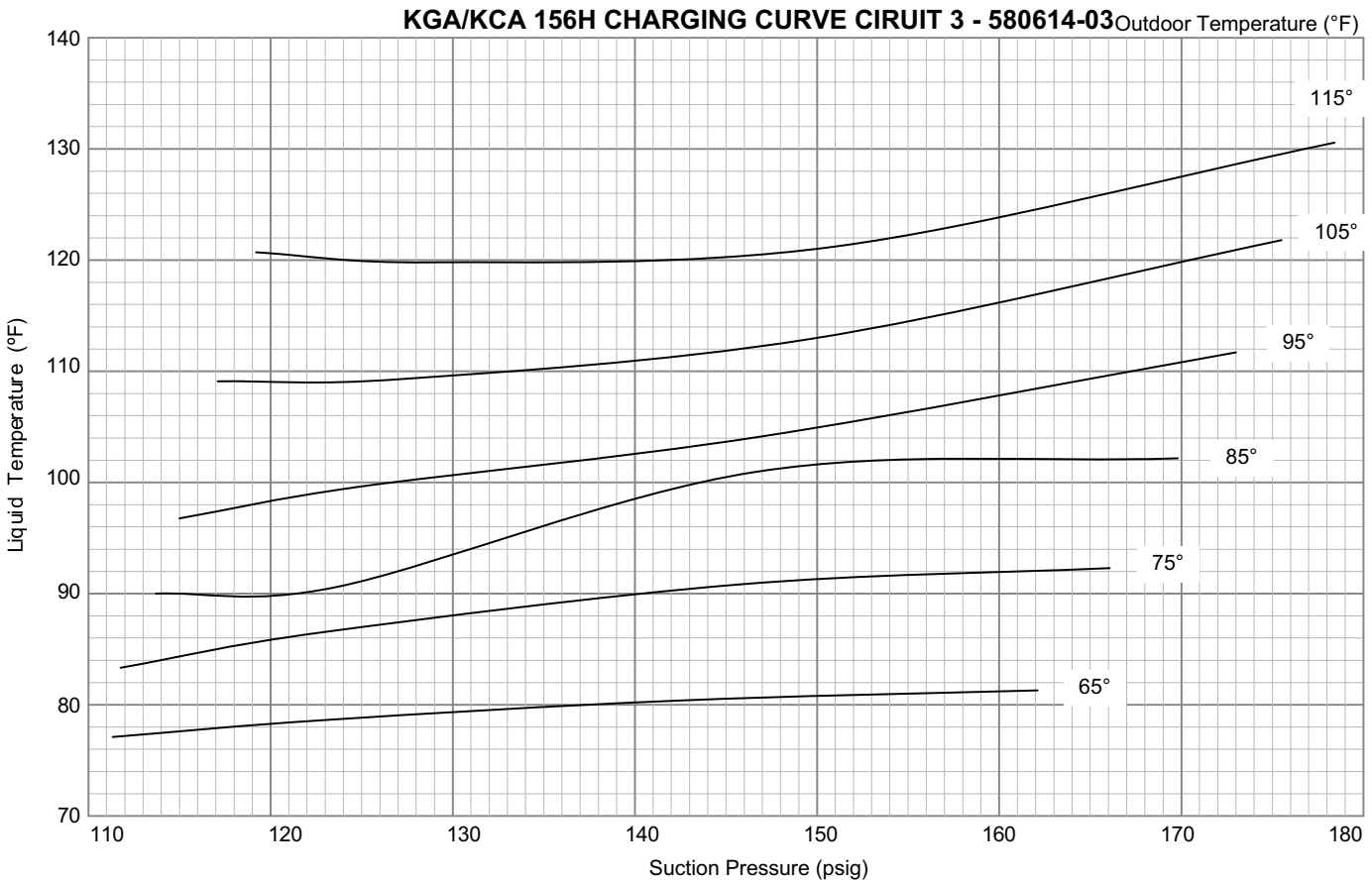
Normal Operating Pressures												
	Outdoor Coil Entering Air Temperature											
	65 °F		75 °F		85 °F		95 °F		105 °F		115 °F	
	Suct (psig)	Disc (psig)	Suct (psig)	Disc (psig)	Suct (psig)	Disc (psig)	Suct (psig)	Disc (psig)	Suct (psig)	Disc (psig)	Suct (psig)	Disc (psig)
Circuit 1	110	232	108	274	110	319	112	372	114	457	116	577
	119	236	119	272	119	318	120	373	123	445	126	534
	138	243	141	282	143	324	142	373	144	428	147	497
	157	251	161	289	165	330	167	376	170	429	171	494
Circuit 2	103	237	104	275	107	318	109	367	112	440	114	558
	114	239	114	275	116	319	117	368	121	434	123	525
	135	244	138	283	140	323	140	371	141	427	144	495
	154	252	158	289	161	331	164	376	167	427	169	488
Circuit 3	111	248	112	289	114	336	115	387	117	477	119	603
	123	254	123	290	124	337	125	390	127	454	129	559
	142	264	146	304	147	347	147	395	150	450	151	523
	162	273	166	313	170	356	173	402	176	455	178	516



KGA/KCA 156H CHARGING CURVE CIRCUIT 2 - 580614-03

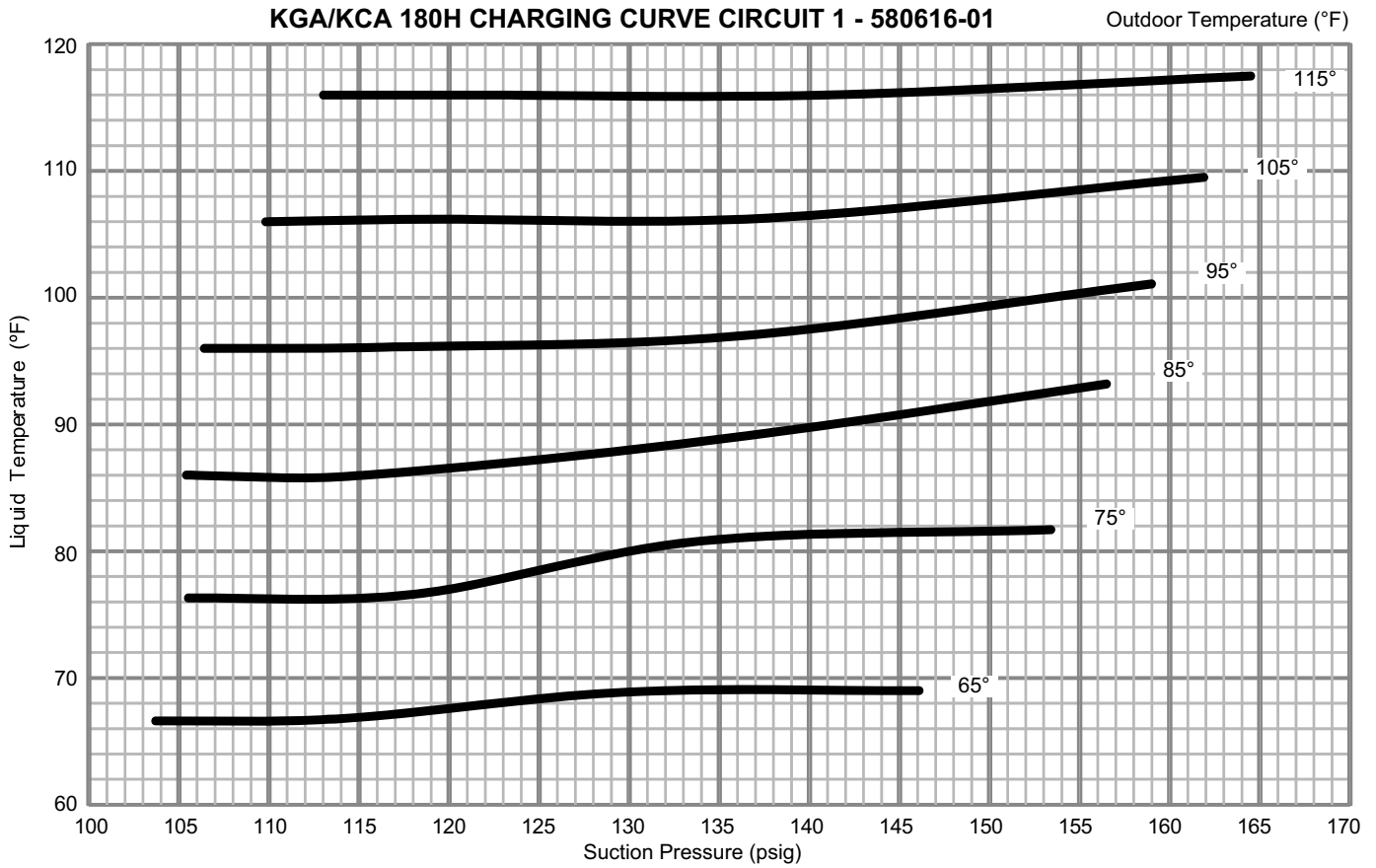


KGA/KCA 156H CHARGING CURVE CIRCUIT 3 - 580614-03



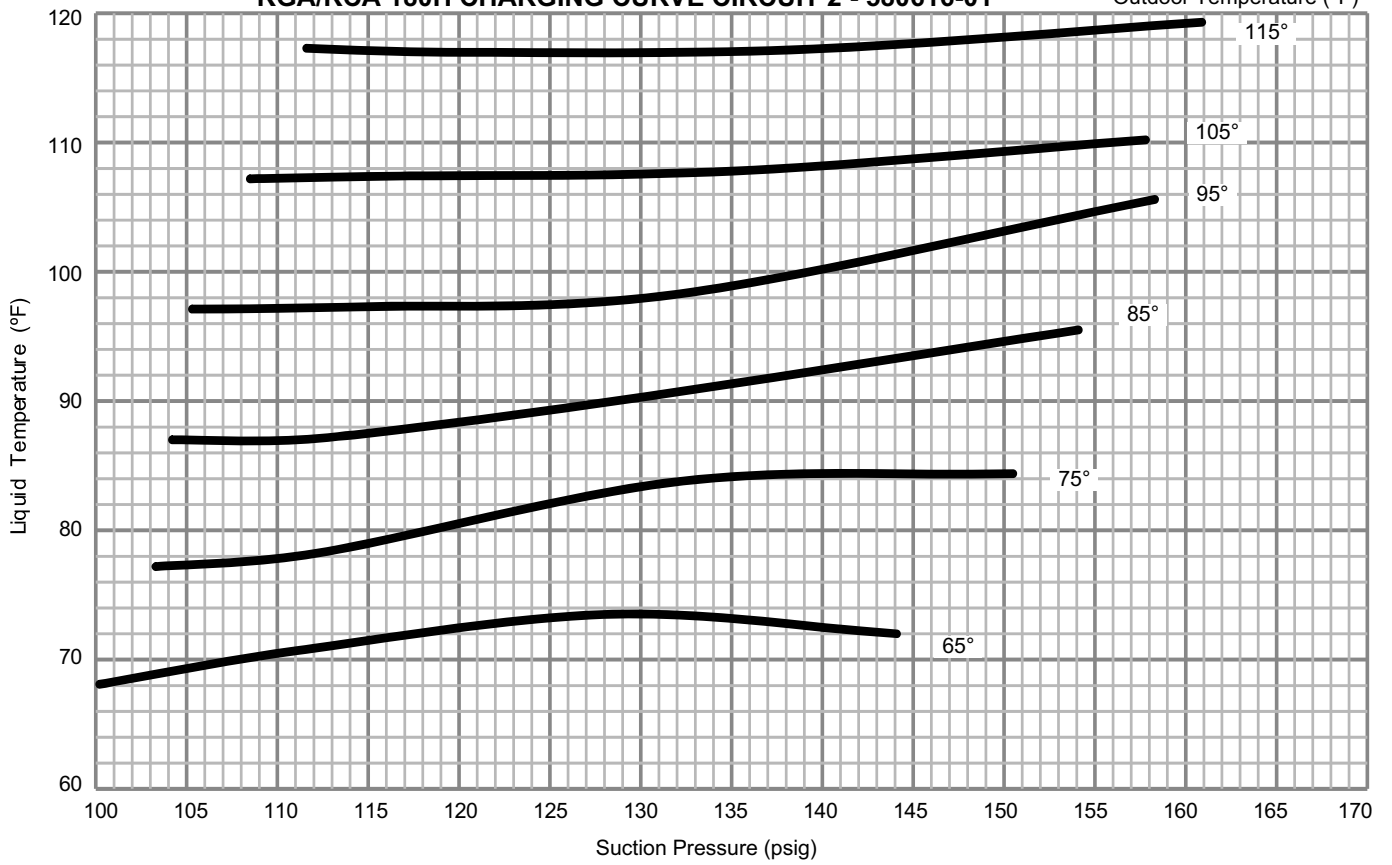
**TABLE 9
KGA/KCA 180H ALL-ALUMINUM OD COIL NORMAL OPERATING PRESSURES - 580617-01**

Normal Operating Pressures												
	Outdoor Coil Entering Air Temperature											
	65 °F		75 °F		85 °F		95 °F		105 °F		115 °F	
	Suct (psig)	Disc (psig)	Suct (psig)	Disc (psig)	Suct (psig)	Disc (psig)	Suct (psig)	Disc (psig)	Suct (psig)	Disc (psig)	Suct (psig)	Disc (psig)
Circuit 1	104	235	106	275	105	326	106	389	110	466	113	552
	114	238	118	275	115	319	117	378	119	447	122	527
	130	245	134	281	136	320	136	365	138	424	141	483
	146	253	153	289	157	330	159	374	162	421	165	478
Circuit 2	100	241	103	281	104	327	105	379	109	442	112	513
	111	244	112	282	113	327	115	379	116	445	119	507
	128	249	132	286	131	331	132	377	135	434	139	488
	144	257	151	295	154	336	158	382	158	439	161	498
Circuit 3	106	241	110	278	110	326	111	380	114	447	117	536
	118	242	115	282	120	326	120	380	123	437	126	512
	134	250	138	287	140	328	139	378	142	431	145	491
	151	260	157	298	160	340	163	385	165	435	167	494



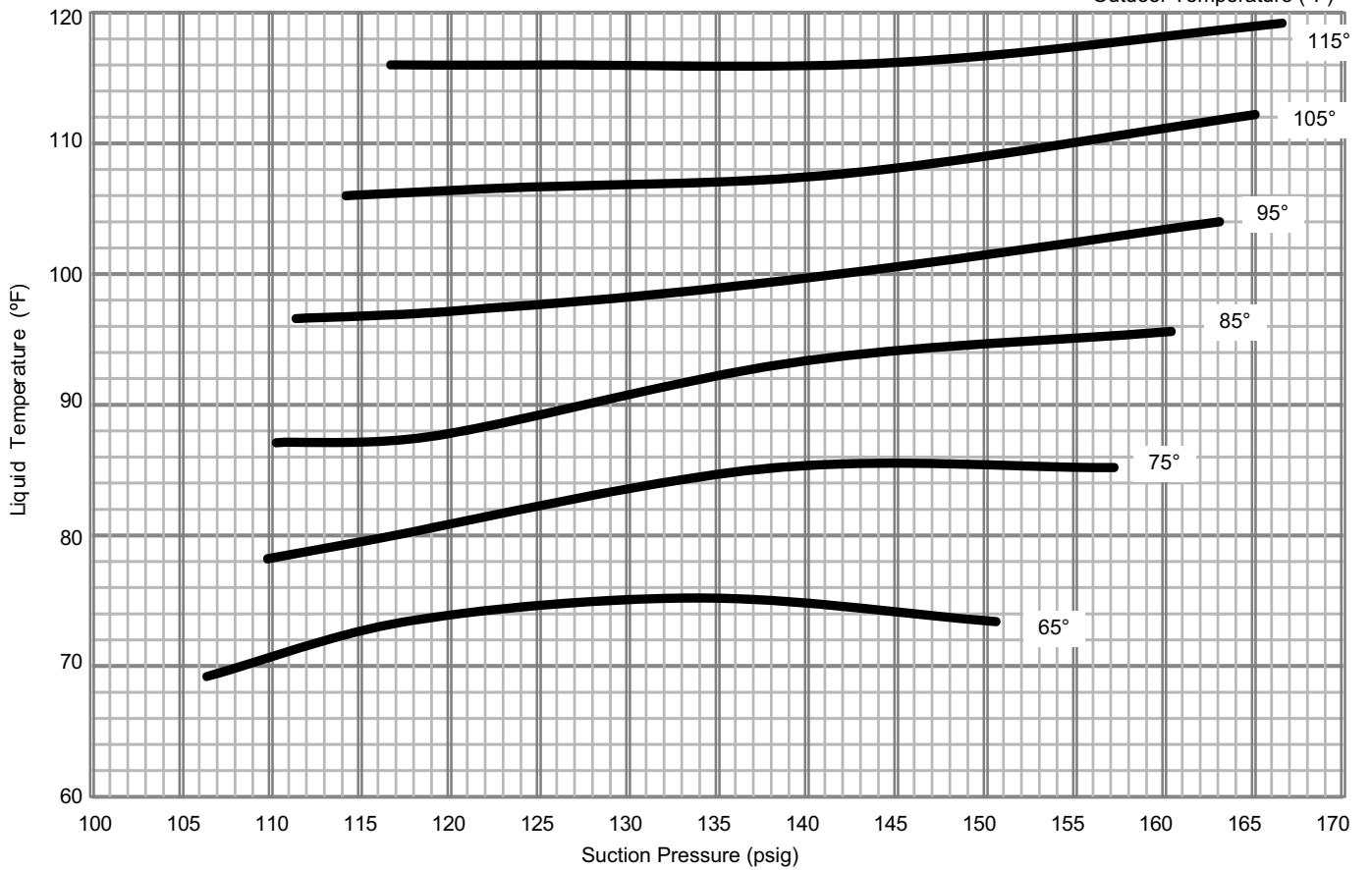
KGA/KCA 180H CHARGING CURVE CIRCUIT 2 - 580616-01

Outdoor Temperature (°F)



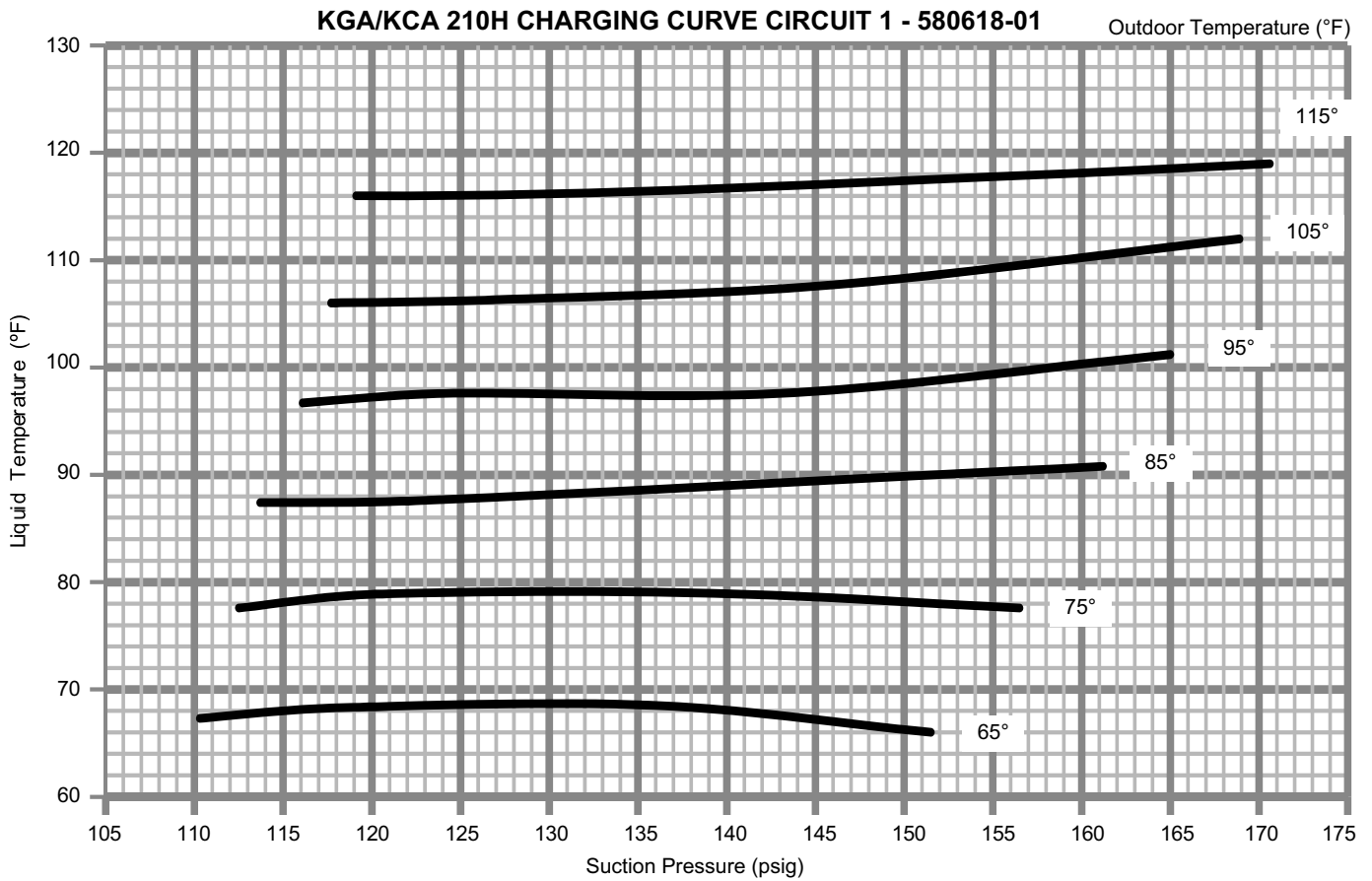
KGA/KCA 180H CHARGING CURVE CIRCUIT 3 - 580616-01

Outdoor Temperature (°F)



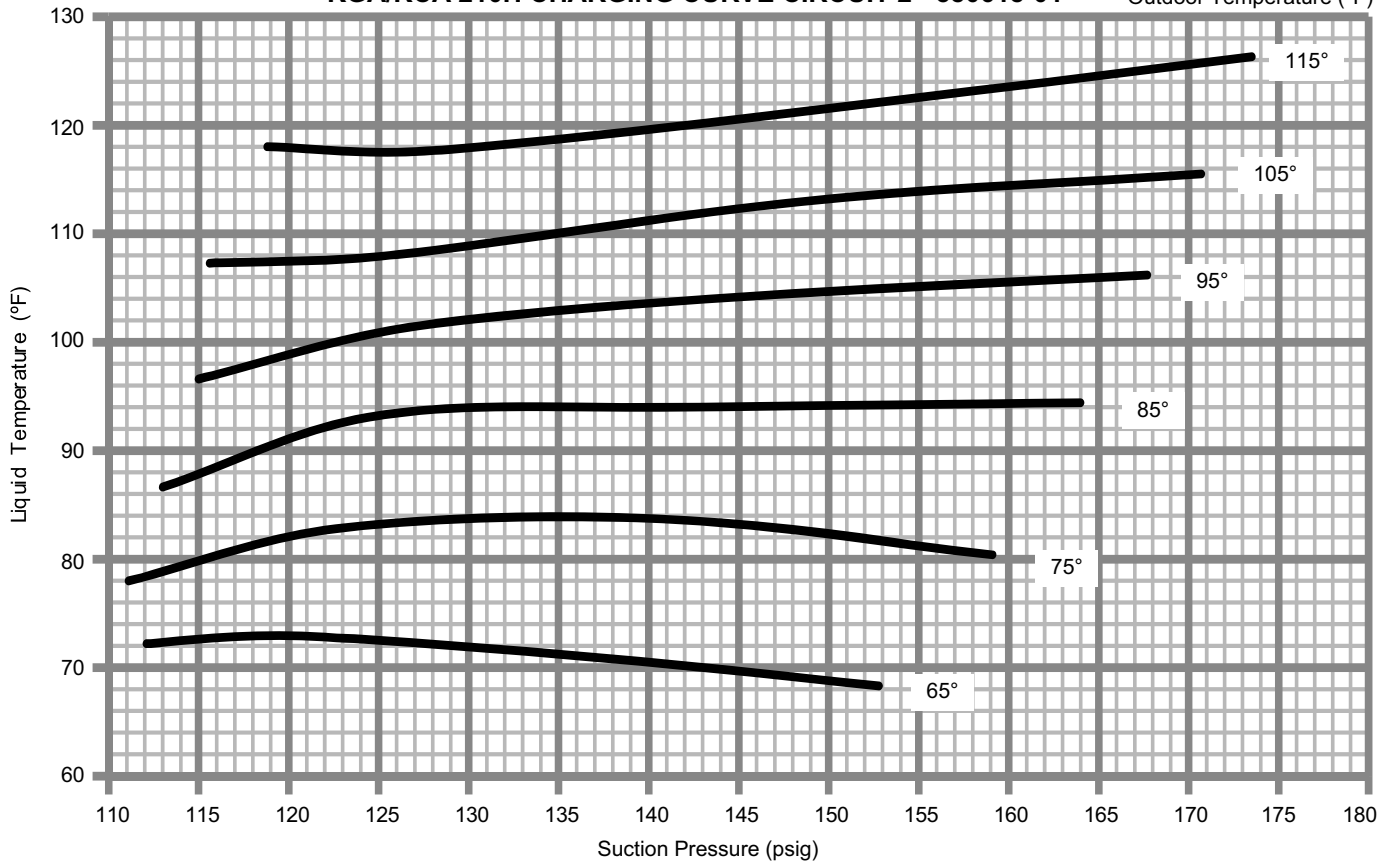
**TABLE 10
KGA/KCA 210H ALL-ALUMINUM COIL NORMAL OPERATING PRESSURES - 580619-01**

Normal Operating Pressures												
	Outdoor Coil Entering Air Temperature											
	65 °F		75 °F		85 °F		95 °F		105 °F		115 °F	
	Suct (psig)	Disc (psig)	Suct (psig)	Disc (psig)	Suct (psig)	Disc (psig)	Suct (psig)	Disc (psig)	Suct (psig)	Disc (psig)	Suct (psig)	Disc (psig)
Circuit 1	110	228	113	262	114	302	116	349	118	402	119	466
	119	231	121	266	123	305	125	352	127	405	128	466
	136	238	139	271	141	312	143	358	146	409	149	464
	152	246	157	277	161	319	165	363	169	414	171	472
Circuit 2	112	232	111	267	113	312	115	358	116	414	119	479
	121	235	123	272	125	311	127	357	126	415	129	476
	137	242	141	278	144	317	146	365	149	415	151	471
	153	253	159	289	164	333	168	374	171	425	174	478
Circuit 3	105	241	106	284	108	327	110	375	112	429	115	489
	112	244	115	282	118	323	121	369	121	428	123	487
	130	251	132	289	135	332	138	378	141	428	145	484
	146	261	151	297	156	339	159	386	163	437	165	495



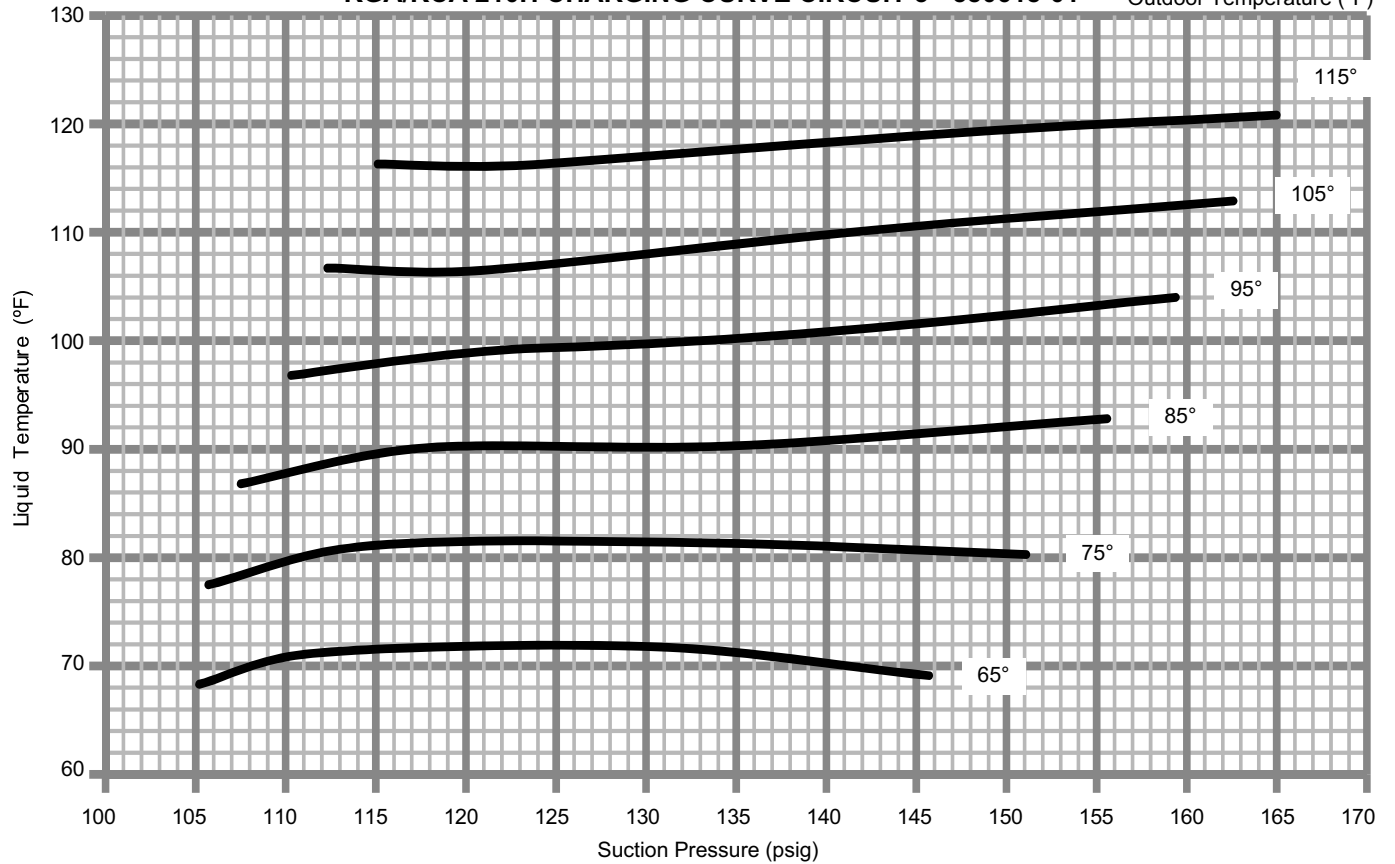
KGA/KCA 210H CHARGING CURVE CIRCUIT 2 - 580618-01

Outdoor Temperature (°F)



KGA/KCA 210H CHARGING CURVE CIRCUIT 3 - 580618-01

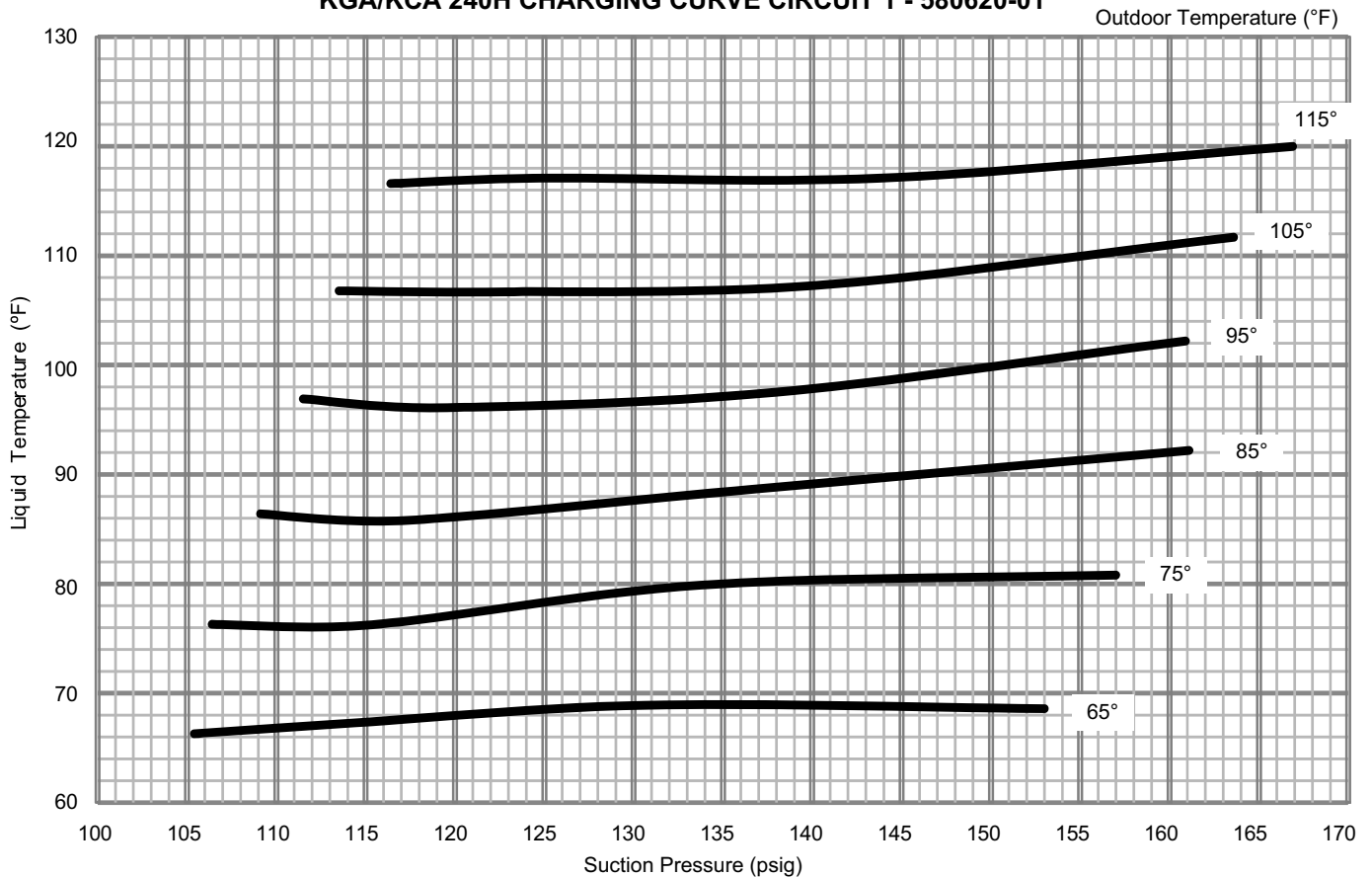
Outdoor Temperature (°F)



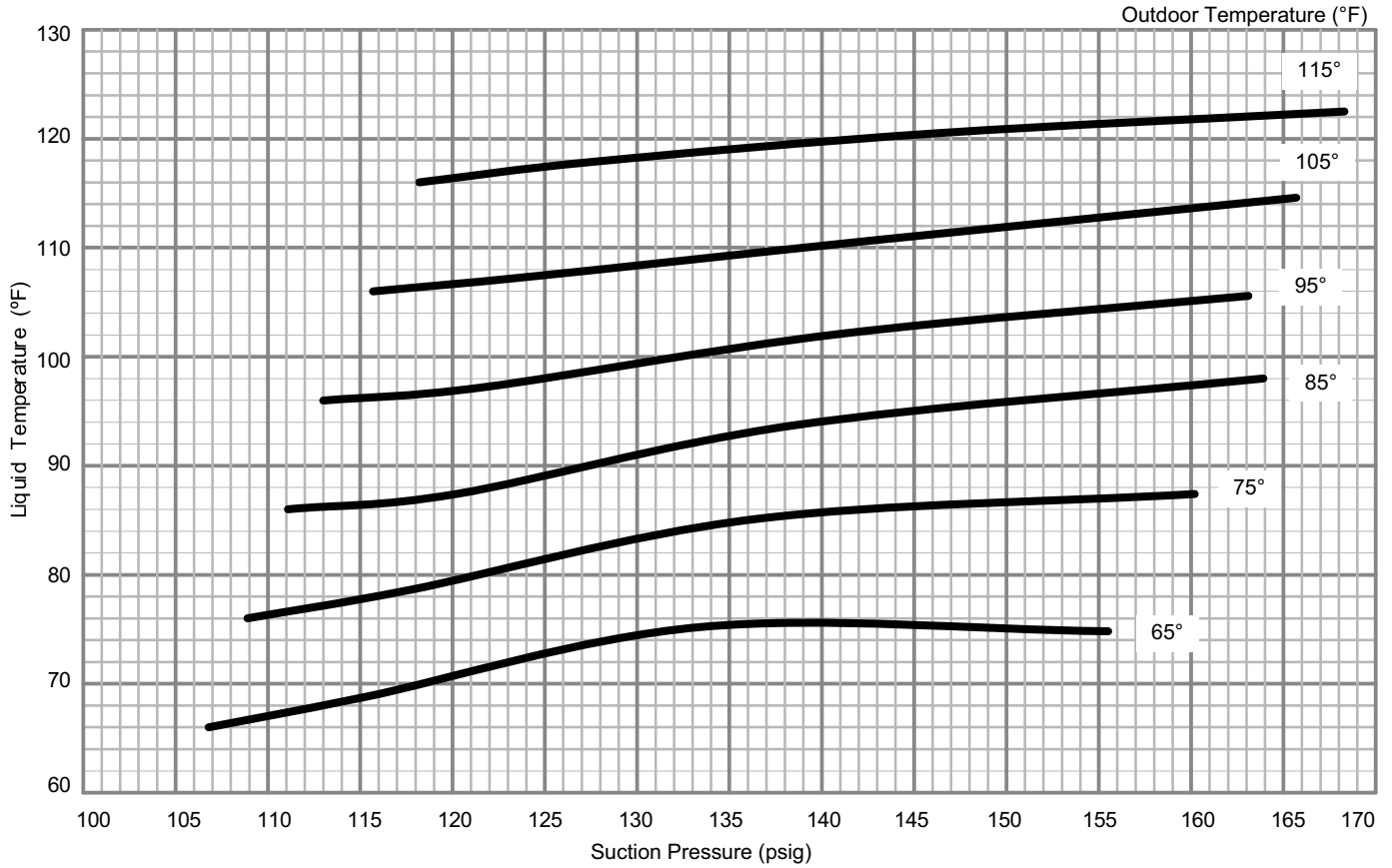
**TABLE 11
KGA/KCA 240H ALL-ALUMINUM OD COIL NORMAL OPERATING PRESSURES - 580621-01**

Normal Operating Pressures												
	Outdoor Coil Entering Air Temperature											
	65 °F		75 °F		85 °F		95 °F		105 °F		115 °F	
	Suct (psig)	Disc (psig)	Suct (psig)	Disc (psig)	Suct (psig)	Disc (psig)	Suct (psig)	Disc (psig)	Suct (psig)	Disc (psig)	Suct (psig)	Disc (psig)
Circuit 1	107	249	109	286	111	331	113	391	116	450	118	513
	115	251	118	285	120	332	122	383	125	443	128	513
	134	255	136	291	139	334	141	383	143	441	146	506
	156	269	160	305	164	352	163	393	166	451	168	508
Circuit 2	105	236	106	277	109	320	112	373	114	445	116	538
	114	239	116	275	117	323	119	372	122	438	125	530
	131	245	134	279	136	322	138	372	140	427	144	489
	153	257	157	291	161	337	161	377	164	433	167	486
Circuit 3	110	247	112	286	114	330	115	386	117	444	119	507
	119	251	121	289	122	334	123	384	126	442	128	512
	136	259	139	298	141	341	144	389	145	445	147	506
	157	276	162	314	166	358	166	399	168	457	170	511
Circuit 4	104	240	106	276	108	319	110	372	111	435	115	492
	113	244	114	280	117	320	117	371	120	432	123	497
	128	251	131	289	133	331	136	376	139	430	142	486
	149	264	154	301	157	345	157	387	161	442	165	493

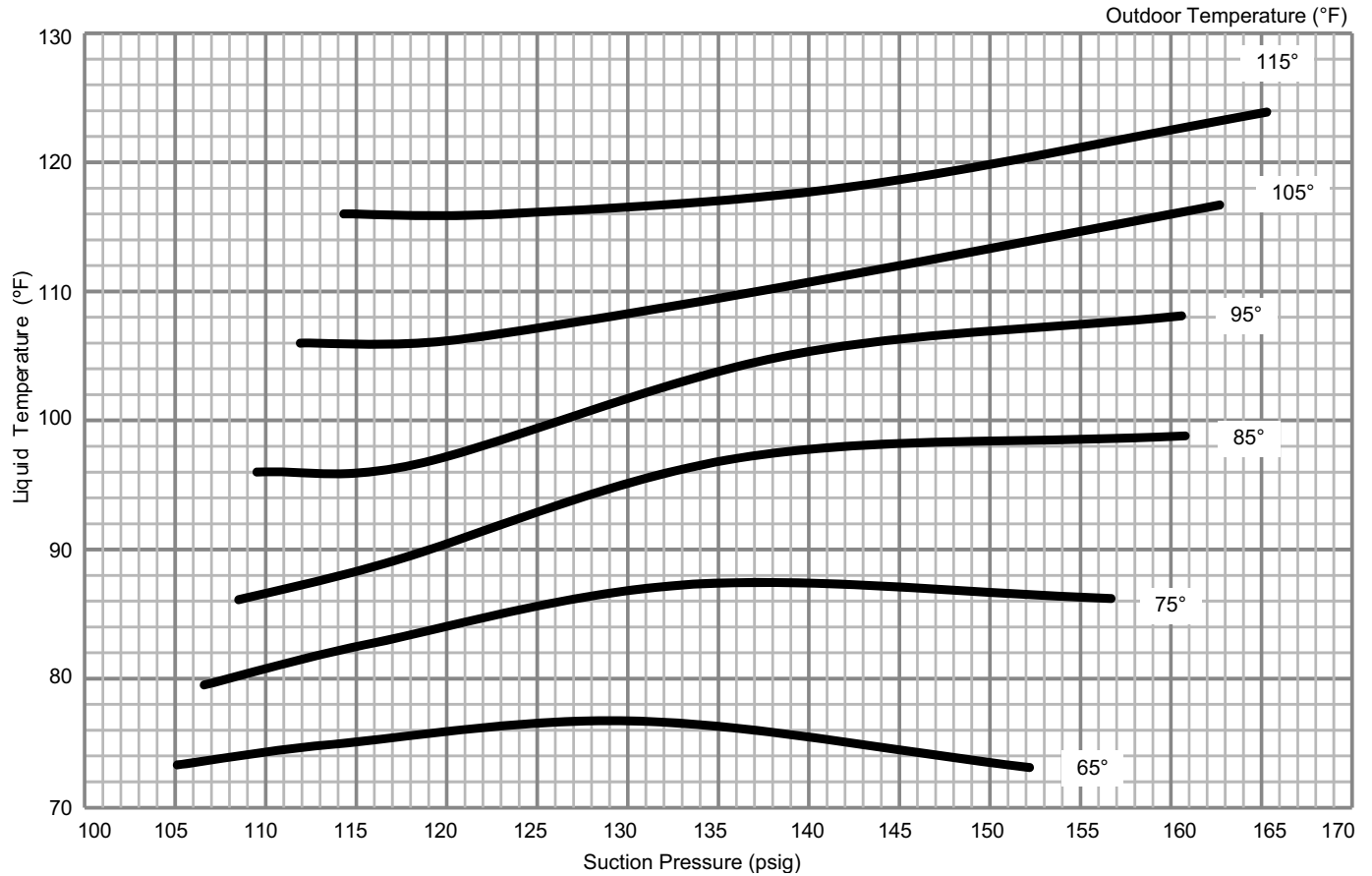
KGA/KCA 240H CHARGING CURVE CIRCUIT 1 - 580620-01



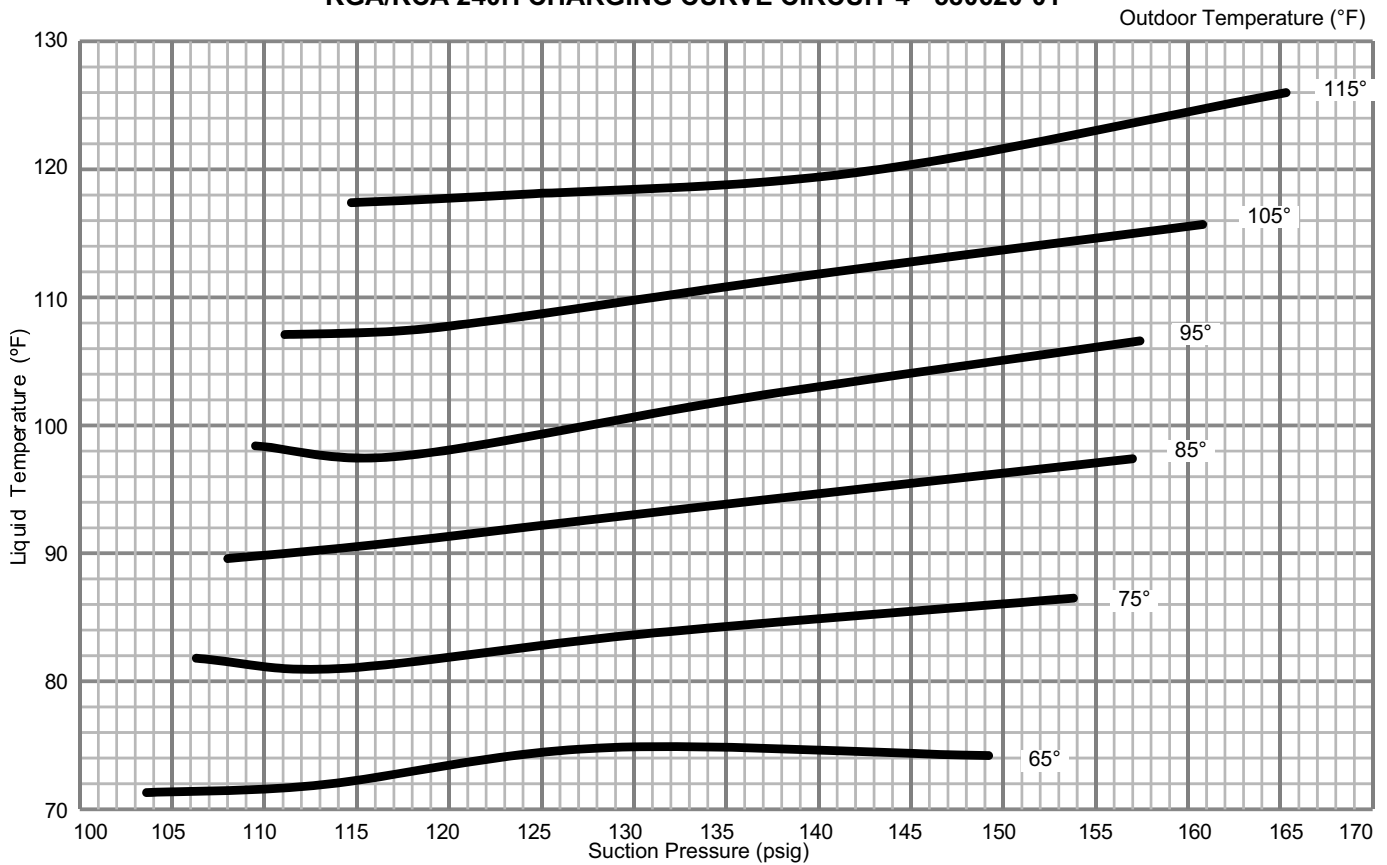
KGA/KCA 240H CAV & STAGED BLOWER CHARGING CURVE CIRCUIT 2 - 580620-01



KGA/KCA 240H CHARGING CURVE CIRCUIT 3 - 580620-01



KG/KCA 240H CHARGING CURVE CIRCUIT 4 - 580620-01



D-Refrigerant Charge and Check - Fin/Tube Coil

WARNING-Do not exceed nameplate charge under any condition.

This unit is factory charged and should require no further adjustment. If the system requires additional refrigerant, reclaim the charge, evacuate the system and add required nameplate charge.

*NOTE - System charging is not recommended below 60°F (15°C). In temperatures below 60°F (15°C), the charge **must** be weighed into the system.*

If weighing facilities are not available, or to check the charge, use the following procedure:

IMPORTANT - Charge unit in normal cooling mode.

- 1- Attach gauge manifolds and operate unit in cooling mode with economizer disabled until system stabilizes (approximately five minutes). Make sure all outdoor air dampers are closed.
- 2- Check each system separately with all stages operating.
- 3- Use a thermometer to accurately measure the outdoor ambient temperature.
- 4- Apply the outdoor temperature to tables 12 through 15 to determine normal operating pressures. Pressures are listed for sea level applications at 80°F dry bulb and 67°F wet bulb return air.

5- Compare the normal operating pressures to the pressures obtained from the gauges. Minor variations in these pressures may be expected due to differences in installations. Significant differences could mean that the system is not properly charged or that a problem exists with some component in the system. **Correct any system problems before proceeding.**

6- If discharge pressure is high, remove refrigerant from the system. If discharge pressure is low, add refrigerant to the system.

- Add or remove charge in increments.
- Allow the system to stabilize each time refrigerant is added or removed.

7- Use the following approach method along with the normal operating pressures to confirm readings.

**TABLE 12 - 580923-01
KGB/KCB180S Fin/Tube With and Without Reheat**

Outdoor Coil Entering Air Temp	Circuit 1		Circuit 2		Circuit 3	
	Dis. ±10 psig	Suc. ±5 psig	Dis. ±10 psig	Suc. ±5 psig	Dis. ±10 psig	Suc. ±5 psig
65°F	270	124	263	122	286	129
75°F	317	133	311	131	333	137
85°F	360	137	353	136	375	142
95°F	411	142	403	140	426	146
105°F	465	146	455	144	480	149
115°F	525	148	512	147	538	149

TABLE 13 - 580924-01
KGB/KCB210S Fin/Tube With and Without Reheat

Outdoor Coil Entering Air Temp	Circuit 1		Circuit 2		Circuit 3	
	Dis. ±10 psig	Suc. ±5 psig	Dis. ±10 psig	Suc. ±5 psig	Dis. ±10 psig	Suc. ±5 psig
65°F	280	126	279	124	298	126
75°F	323	133	322	131	341	132
85°F	368	138	367	136	387	136
95°F	418	142	415	140	437	140
105°F	471	145	468	144	491	143
115°F	530	148	525	147	550	147

TABLE 14 - 580925-01
KGB/KCB240S Fin/Tube With and Without Reheat

Outdoor Coil Entering Air Temp	Circuit 1		Circuit 2		Circuit 3	
	Dis. ±10 psig	Suc. ±5 psig	Dis. ±10 psig	Suc. ±5 psig	Dis. ±10 psig	Suc. ±5 psig
65°F	257	119	271	125	289	119
75°F	297	125	311	131	332	125
85°F	342	131	354	136	378	129
95°F	390	136	401	139	426	133
105°F	441	140	452	143	478	136
115°F	496	142	507	146	533	140

TABLE 15 580940-01
KGB/KCB 300S Fin/Tube With and Without Reheat

Outdoor Coil Entering Air Temp	Circuit 1		Circuit 2		Circuit 3		Circuit 4	
	Dis. ±10 psi	Suc. ±5 psi	Dis. ±10 psi	Suc. ±5 psi	Dis. ±10 psi	Suc. ±5 psi	Dis. ±10 psi	Suc. ±5 psi
65°F	272	129	273	128	280	129	277	127
75°F	311	132	303	131	321	131	317	129
85°F	357	134	349	133	367	133	363	130
95°F	403	137	397	137	418	135	406	134
105°F	451	139	453	140	475	138	471	136
115°F	502	142	506	142	532	144	529	140

E-Charge Verification - Approach Method - AHRI Testing (Fin/Tube Coil)

- Using the same thermometer, compare liquid temperature to outdoor ambient temperature.
 Approach Temperature = Liquid temperature (at condenser outlet) minus ambient temperature.
- Approach temperature should match values in table 16. An approach temperature greater than value shown indicates an undercharge. An approach temperature less than value shown indicates an overcharge.
- The approach method is not valid for grossly over or undercharged systems. Use tables 12 through 15 as a guide for typical operating pressures.

TABLE 16
Approach Temperatures - Fin/Tube Coil

KG/KB Unit	Liquid Temp. Minus Ambient Temp.			
	1st Stage	2nd Stage	3rd Stage	4th Stage
180S	2°F + 1 (1.1°C ±0.5)	2°F + 1 (1.1°C ±0.5)	5°F + 1 (2.8°C ±0.5)	NA
210S	5°F + 1 (2.8°C ±0.5)	4°F + 1 (2.2°C ±0.5)	8°F + 1 (4.4°C ±0.5)	NA
240S	5°F + 1 (2.8°C ±0.5)	5°F + 1 (2.8°C ±0.5)	9°F + 1 (5.0°C ±0.5)	NA
300S	6°F + 1 (3.3°C ±0.5)	6°F + 1 (3.3°C ±0.5)	7°F + 1 (3.9°C ±0.5)	7°F + 1 (3.9°C ±0.5)

F-Compressor Controls

See unit wiring diagram to determine which controls are used on each unit. Optional controls are identified on wiring diagrams by arrows at junction points.

- Freezestats (S49, S50, S53, S95)
 Switches de-energize compressors when evaporator coil temperature falls below 29°F (-2°C) to prevent evaporator freeze-up. Switches reset when evaporator coil temperature reaches 58°F (15°C).
- High Pressure Switches (S4, S7, S28, S96)
 Switches open to de-energize appropriate compressor at 640 psig ± 20 psig (4413kPa ± 138kPa). Switch must be manually reset.
- Thermal Protector (S5, S8, S31, S180)
 The compressors used on 156H, 180S/H, 210S/H, 240S/H and 300S units are each protected by an internal thermal protector switch.
- Crankcase Heater (HR1, HR2, HR5, HR11)
 Units have compressors which contain a belly band compressor oil heater which must be on 24 hours before running compressors. Energize by setting thermostat so that there is no cooling demand, to prevent compressor from cycling, and apply power to unit.

Gas Heat Start-Up (Gas Units)

FOR YOUR SAFETY READ BEFORE LIGHTING

⚠ WARNING



Electric shock hazard. Can cause injury or death. Do not use this unit if any part has been under water. Immediately call a qualified service technician to inspect the unit and to replace any part of the control system and any gas control which has been under water.

⚠ WARNING



Danger of explosion. Can cause injury or product or property damage. If overheating occurs or if gas supply fails to shut off, shut off the manual gas valve to the appliance before shutting off electrical supply.

⚠ WARNING



Electric shock hazard. Can cause injury or death. Before attempting to perform any service or maintenance, turn the electrical power to unit OFF at disconnect switch(es). Unit may have multiple power supplies.

⚠ WARNING

SMOKE POTENTIAL

The heat exchanger in this unit could be a source of smoke on initial firing. Take precautions with respect to building occupants and property. Vent initial supply air outside when possible.

BEFORE LIGHTING smell all around the appliance area for gas. Be sure to smell next to the floor because some gas is heavier than air and will settle on the floor.

Use only your hand to push in or turn the gas control knob. Never use tools. If the knob will not push in or turn by hand, do not try to repair it, call a qualified service technician. Force or attempted repair may result in a fire or explosion.

⚠ WARNING



Danger of explosion. Can cause injury or death. Do not attempt to light manually. Unit has a direct spark ignition system.

This unit is equipped with an automatic spark ignition system. There is no pilot. In case of a safety shutdown, move thermostat switch to **OFF** and return the thermostat switch to **HEAT** to reset ignition control.

A-Placing Unit In Operation

⚠ WARNING



Danger of explosion and fire. Can cause injury or product or property damage. You must follow these instructions exactly.

Gas Valve Operation Honeywell VR8205Q/VR8305Q and White Rodgers 36H54 (figure 19 and 20)

- 1- Set thermostat to lowest setting.
- 2- Turn off all electrical power to appliance.
- 3- This appliance is equipped with an ignition device which automatically lights the burner. Do **not** try to light the burner by hand.
- 4- Open or remove the heat section access panel.

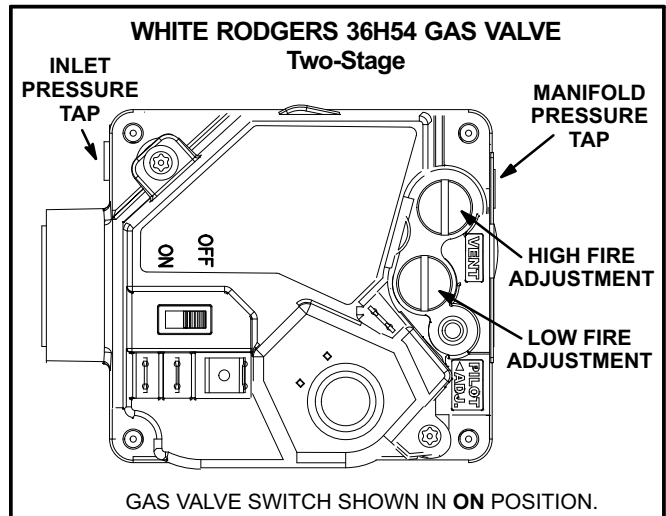


FIGURE 19

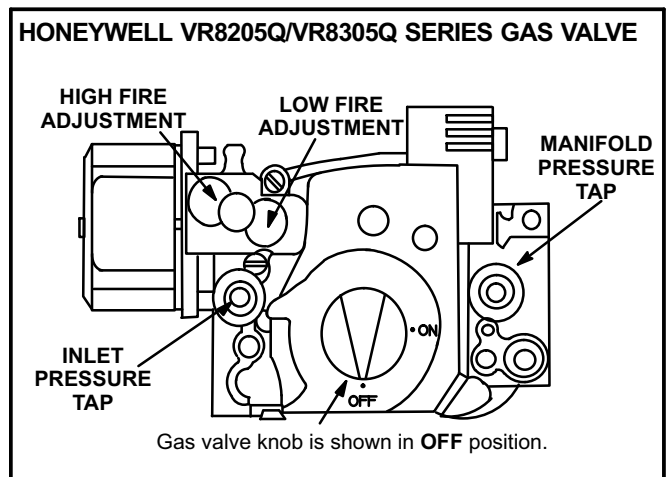


FIGURE 20

Heating Operation and Adjustments

(Gas Units)

First Stage Heat:

- 1- The thermostat initiates W1 heating demand.
- 2- 24VAC is routed from TB1 to ignition control A3 through P117. A3 proves N.C. primary limit S10 and N.C. rollout switch S47.
- 3- Combustion air inducer blower B6 is energized.
- 4- After the combustion air inducer B6 has reached full speed, the combustion air proving switch S18 contacts close.
- 5- After a 30 second delay A3 energizes the ignitor and LO terminal (low fire) of gas valve GV1.

Second Stage Heat:

- 6- With first stage heat operating, an additional heating demand from the thermostat initiates W2.
- 7- The second stage heat signal passes from TB1 to A3.
- 8- A3 energizes HI terminal (high fire) of gas valve GV1.

End of Second Stage Heat:



- 9- Heating demand is satisfied. Terminal W2 (high fire) is de-energized.
- 10- Terminal HI of GV1 is de-energized by A3 control module.

End of First Stage Heat:


- 11- Heating demand is satisfied. Terminal W1 (low fire) is de-energized.
- 12- Ignition A3 is de-energized by TB1 in turn de-energizing terminal LO of GV1.

Optional Low Ambient Kit: (CSA -50°C Low Ambient Kit)

- 13- Line voltage (or transformer T20 in 460V and 575V only) is routed through the low ambient kit fuses F20 and N.C. low ambient kit thermostats S60 and S61, to energize low ambient kit heater HR6.

- 5- Turn gas valve switch to **OFF**. See figure 19. On Honeywell VR8305Q gas valves, turn the knob on the gas valve clockwise  to “OFF”. Do not force. See figure 20.
- 6- Wait five (5) minutes to clear out any gas. If you then smell gas, **STOP!** Immediately call your gas supplier from a neighbor's phone. Follow the gas supplier's instructions. If you do not smell gas, go to the next step.
- 7- Turn gas valve switch to **ON**. See figure 19. On Honeywell VR8305Q gas valves, turn the knob on the gas valve counterclockwise  to “ON”. Do not force. See figure 20.
- 8- Close or replace the heat section access panel.
- 9- Turn on all electrical power to appliance.
- 10- Set thermostat to desired setting.
- 11- The ignition sequence will start.
- 12- If the appliance does not light the first time (gas line not fully purged), it will attempt up to two more ignitions before locking out.
- 13- If lockout occurs, repeat steps 1 through 10.
- 14- If the appliance will not operate, follow the instructions “Turning Off Gas to Appliance” and call your service technician or gas supplier.

Turning Off Gas to Unit

- 1- If using an electromechanical thermostat, set to the lowest setting.
- 2- Before performing any service, turn off all electrical power to the appliance.
- 3- Open or remove the heat section access panel.
- 4- Turn gas valve switch to **OFF**. On Honeywell VR8305Q gas valves, turn the knob on the gas valve clockwise  to “OFF”. Do not force.
- 5- Close or replace the heat section access panel.

WARNING



Danger of explosion. Can cause injury or death. Do not attempt to light manually. Unit has a direct spark ignition system.

B-Ignition Control Diagnostic LED's

**TABLE 17
IGNITION CONTROL HEARTBEAT LED STATUS**

LED Flashes	Indicates
Slow	Normal operation. No call for heat.
Fast	Normal operation. Call for heat.
Steady Off	Internal control fault OR no power to control OR Gas Valve Relay Fault.
Steady On	Control internal failure.
2	Lockout. Failed to detect or sustain flame.
3	Prove switch open or closed or rollout switch open.
4	Limit switch is open and/or limit has opened three times.
5	Flame sensed but gas valve solenoid not energized.

C-Limit Controls

Limit controls are factory-set and are not adjustable. The primary limit is located on the blower deck to the left side of the the blower housing.

D-Heating Adjustment

Main burners are factory-set and do not require adjustment.

The following manifold pressures are listed on the gas valve.

Natural Gas Units - Low Fire - 1.6" w.c. (not adjustable)

Natural Gas Units - High Fire - 3.7" w.c.

LP Gas Units - Low Fire - 5.5" w.c. (not adjustable)

LP Gas Units - High Fire - 10.5" w.c.

Electric Heat Start-Up (KC Unit)

Electric heat will stage on and cycle with thermostat demand. Number of stages of electric heat will vary depending on electric heat assembly. See electric heat wiring diagram on unit for sequence of operation.

Inverter Start-Up

A-General

Optional supply air inverter units are available which provide two blower speeds. The blower will operate at lower speeds when cooling demand is low and higher speeds when cooling demand is high. This results in lower energy consumption.

Supply air inverter units will operate at high speed during ventilation (blower "G" only signal) but can be adjusted to operate at low speed.

Low speed is approximately 2/3 of the full speed RPM.

B-Set Maximum Blower CFM

- 1- Initiate a blower (G) only signal from the room thermostat or control system.
- 2- Adjust the blower pulley to deliver the full (high speed) CFM in the typical manner. See *Determining Unit CFM* in the Blower Operation and Adjustment section.

C-Set Blower Speed During Ventilation

To save energy during ventilation, the blower speed can be set to low. This is accomplished by changing the ventilation speed switch on the VFD control board to "LO". See figure 21.

Note - On units equipped with an economizer, set damper minimum position as shown in the next section. After adjusting the low speed minimum position, the ventilation speed switch will be in the "LO" position.

D-Set Damper Minimum Position (Units W/ Economizer)

To maintain required minimum ventilation air volumes when the unit is in the occupied mode, two minimum damper positions must be set. A high and a low speed potentiometer are provided on the VFD control board to adjust minimum damper position. See figure 21.

Set High Speed Minimum Position

- 1- Initiate a blower (G) only AND occupied demand from the room thermostat or control system.
- 2- Set the ventilation speed switch on the VFD control board to "HI".
- 3- Rotate the high speed potentiometer on the VFD control board to set the high speed minimum damper position.
- 4- Measure the intake air CFM. If the CFM is lower than the design specified CFM for ventilation air, use the potentiometer to increase the damper percent open. If the CFM is higher than specified, decrease the damper percent open.

Note - Intake air CFM can also be determined using the outdoor air temperature, return air temperature and mixed air temperature. Refer to the economizer or outdoor air damper installation instructions.

Set Low Speed Minimum Position

- 1- Initiate a blower (G) only AND occupied demand from the room thermostat or control system.
- 2- Set the ventilation speed switch on the VFD control board to "LO".
- 3- Rotate the low speed potentiometer on the VFD control board to set the low speed minimum damper position.
- 4- Measure the intake air CFM. If the CFM is lower than the design specified CFM for ventilation air, use the potentiometer to increase the damper percent open.

If the CFM is higher than specified, decrease the damper percent open.

Note - Intake air CFM can also be determined using the outdoor air temperature, return air temperature and mixed air temperature. Refer to the economizer or outdoor air damper installation instructions.

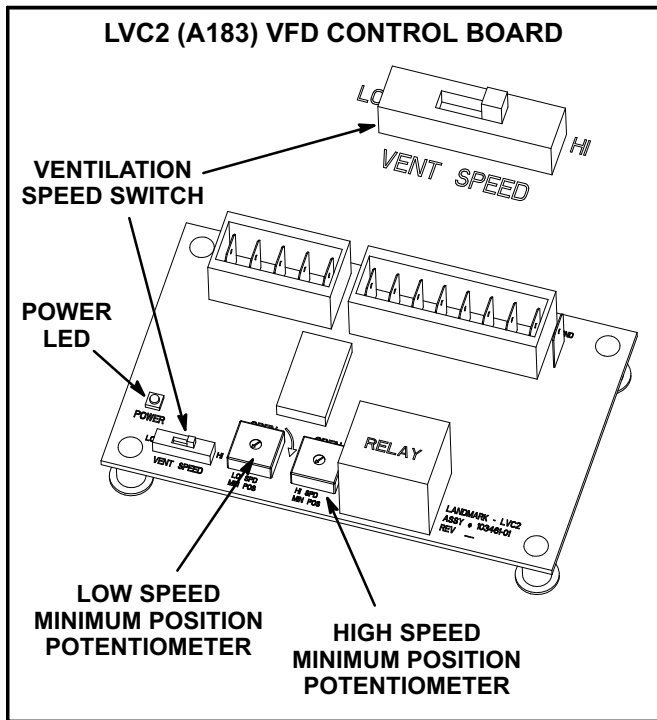


FIGURE 21

Troubleshoot LVC2 Board (A183)

Refer to wiring diagram sections B (unit), C (control) and D (economizer) located on inside of unit panels.

- 1- Inspect the LVC2 for damaged components. Replace the LVC2 if damaged components are found.
- 2- Check all wire connections to LVC2; secure if loose.
- 3- Check for 24VAC signal at the thermostat blower input (G to GND terminal). See figure 22.

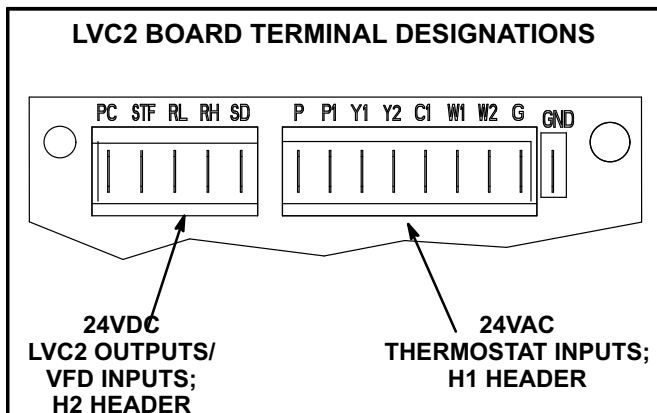


FIGURE 22

- 4- If there is no thermostat signal, troubleshoot back toward the thermostat.
- 5- Check the power LED on the board. See figure 21.
- 6- If the power LED is not on, check voltage between LVC2 terminals PC (H2-1) and SD (H2-5). Voltage should read 24VDC.
- 7- If voltage does not read 24VDC, disconnect the H2 header from the LVC2 VFD terminal block (to make sure the LVC2 is not shorting 24VDC supply from the inverter). Measure the voltage between the end terminals on the H2 header. If 24VDC is present, replace the LVC2 board. If no voltage is read, troubleshoot the VFD.
- 8- When LVC2 24VAC thermostat blower (G) input and 24VDC power are present, check the LVC2 low and high speed outputs. The LVC2 uses inverse logic to enable the blower; 1VDC will be read at the enabled blower speed terminal. See table 18.
- 9- If all inputs are correct and the unit still does not operate as intended, replace LVC2 board.

**TABLE 18
LVC2 BOARD BLOWER OUTPUTS**

Output Terminals	Voltage	Blower Operation
RL-SD	1VDC	Low Speed
RH-SD	24VDC	
RL-SD	24VDC	High Speed
RH-SD	1VDC	
RL-SD	1VDC	Illegal State (replace board)
RH-SD	1VDC	
RL-SD	24VDC	Blower Off (replace board)
RH-SD	24VDC	

Hot Gas Reheat Start-Up And Operation

General

Hot gas reheat units provide a dehumidifying mode of operation. These units contain a reheat coil adjacent to and downstream of the evaporator coil. Reheat coil solenoid valves, L14 and L30, route hot discharge gas from the compressor to the reheat coil. Return air pulled across the evaporator coil is cooled and dehumidified; the reheat coil adds heat to supply air.

See figure 23 for 180S, 210S, and 240S reheat refrigerant routing and figure 24 for 180S, 210S, and 240S normal cooling refrigerant routing. See figure 25 for 300S reheat refrigerant routing and figure 26 for 300S normal cooling refrigerant routing.

L14 and L30 Reheat Coil Solenoid Valves

When room conditions close the dehumidistat switch, L14 and L30 reheat valves are energized and refrigerant is routed to the reheat coil.

Check-Out

Test hot gas reheat operation using the following procedure.

- 1- Make sure reheat is wired as shown in wiring section.
- 2- Initiate a dehumidification demand by adjusting dehumidistat setpoint knob **BELOW** indoor relative humidity. The blower, compressor 1 and compressor 2 should be operating.
- 3- End a dehumidification demand by adjusting setpoint knob **ABOVE** indoor relative humidity. The blower, compressor 1, and compressor 2 should de-energize.

Note - When a reheat demand is present, the blower will operate on high speed.

Default Reheat Operation

Reheat will operate as shown in table 19 once three conditions are met:

- 1- Blower must be operating.
- 2- System must be in occupied mode.
- 3- System must NOT be operating in heating mode.

IMPORTANT - Free cooling does not operate during reheat.

**TABLE 19
REHEAT OPERATION**

Two-Stage Thermostat		
T'stat and Humidity Demands	Operation	
	180S, 210S, 240S (3-Compressors)	300S (4-Compressors)
Reheat Only	Compressor 1 & 2 Reheat	Compressor 1 & 2 Reheat
Reheat & Y1	Compressor 1 & 2 Reheat and Compressor 3 Cooling ¹	Compressor 1 & 2 Reheat and Compressor 3 & 4 Cooling ¹
Reheat & Y1 & Y2	Compressor 1, 2, & 3 Cooling ²	Compressor 1, 2, 3 & 4 Cooling ²

*Cooling stage is initiated when zone temperature is higher than the cooling setpoint plus the appropriate stage differential.

**Reheat demand is initiated when relative humidity is higher than relative humidity setpoint.

¹If there is no reheat demand and outdoor air is suitable, free cooling will operate.

²If there is no reheat demand and outdoor air is suitable, free cooling and compressor 1 and 2 will operate.

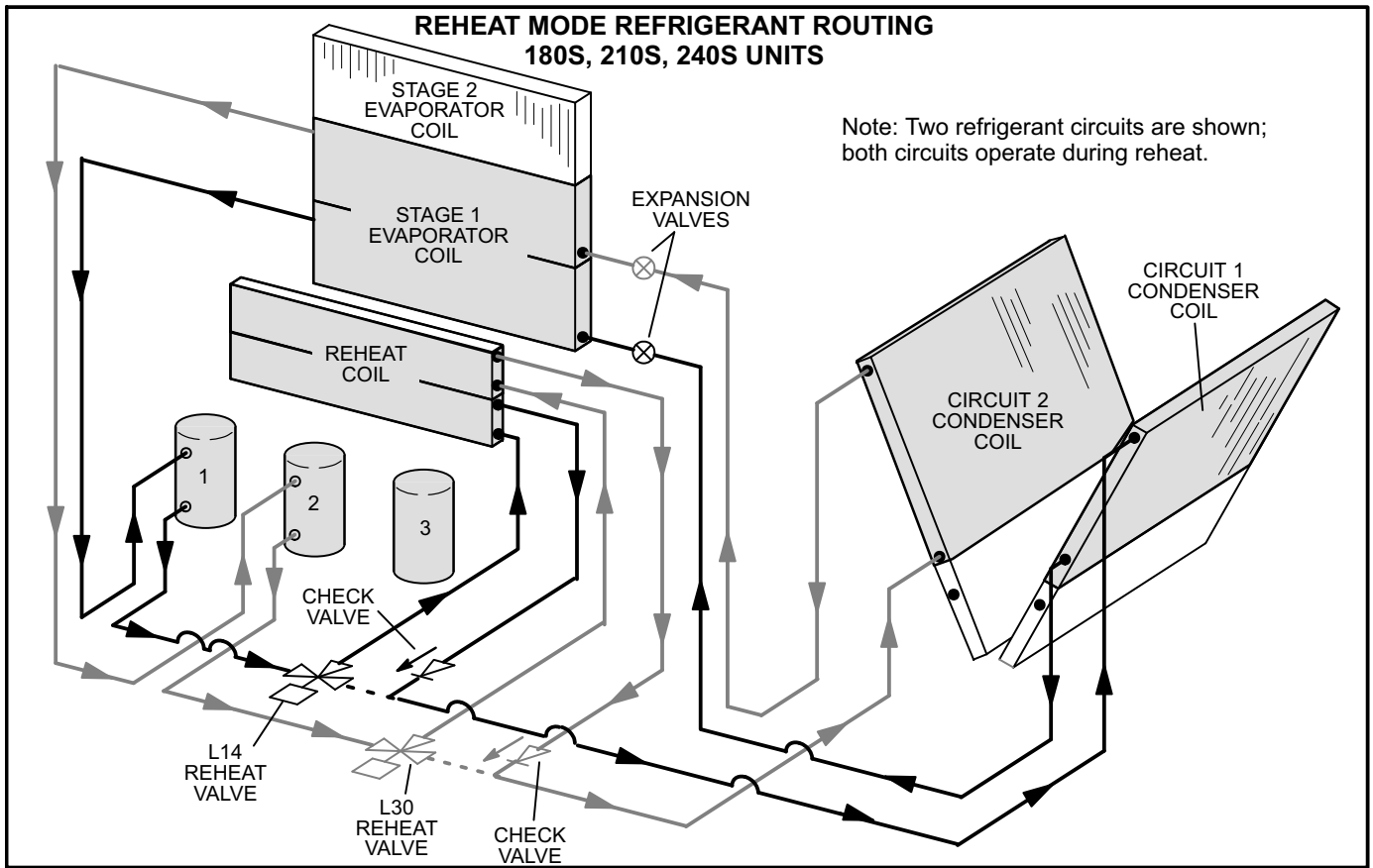


FIGURE 23

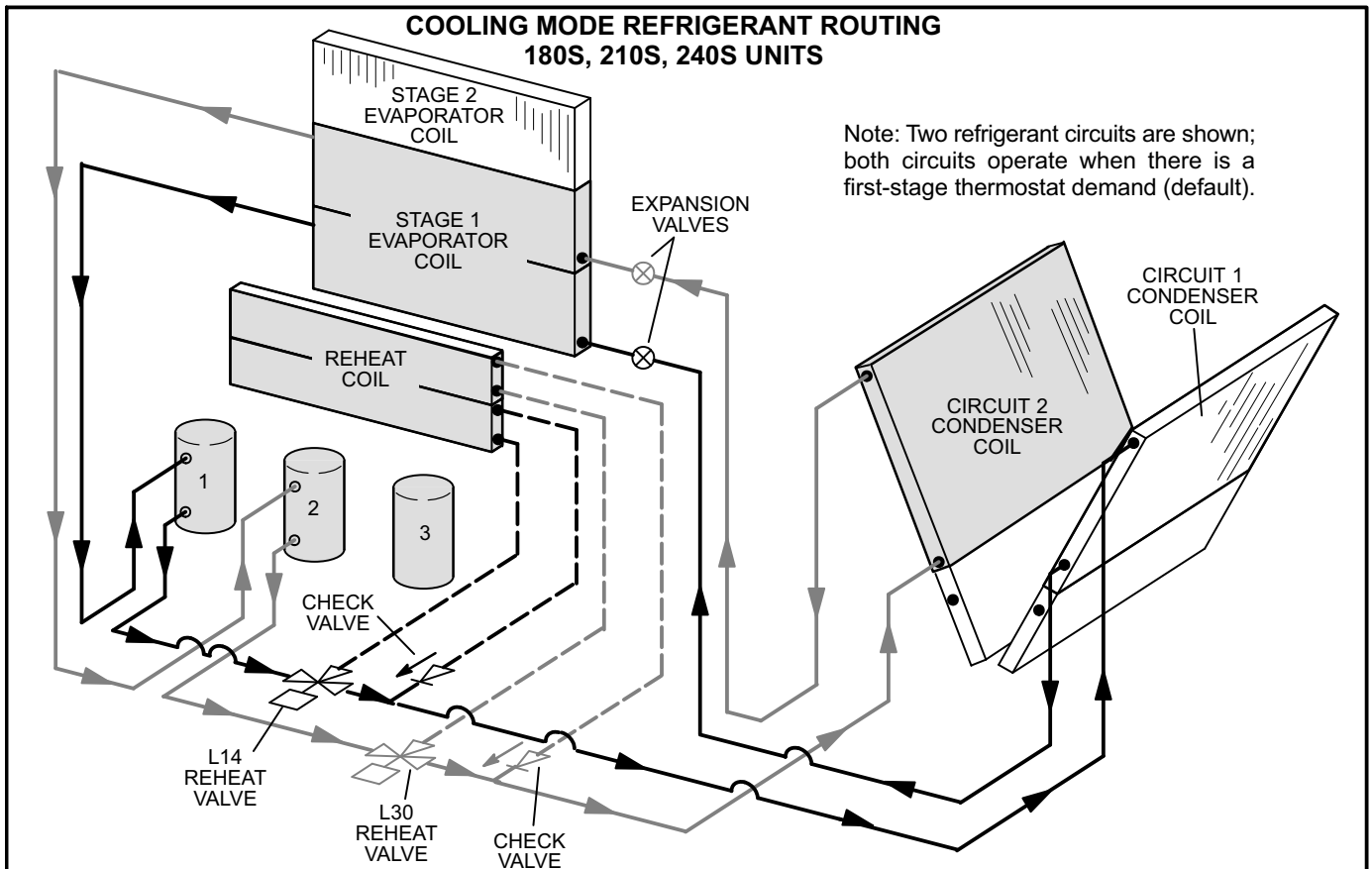


FIGURE 24

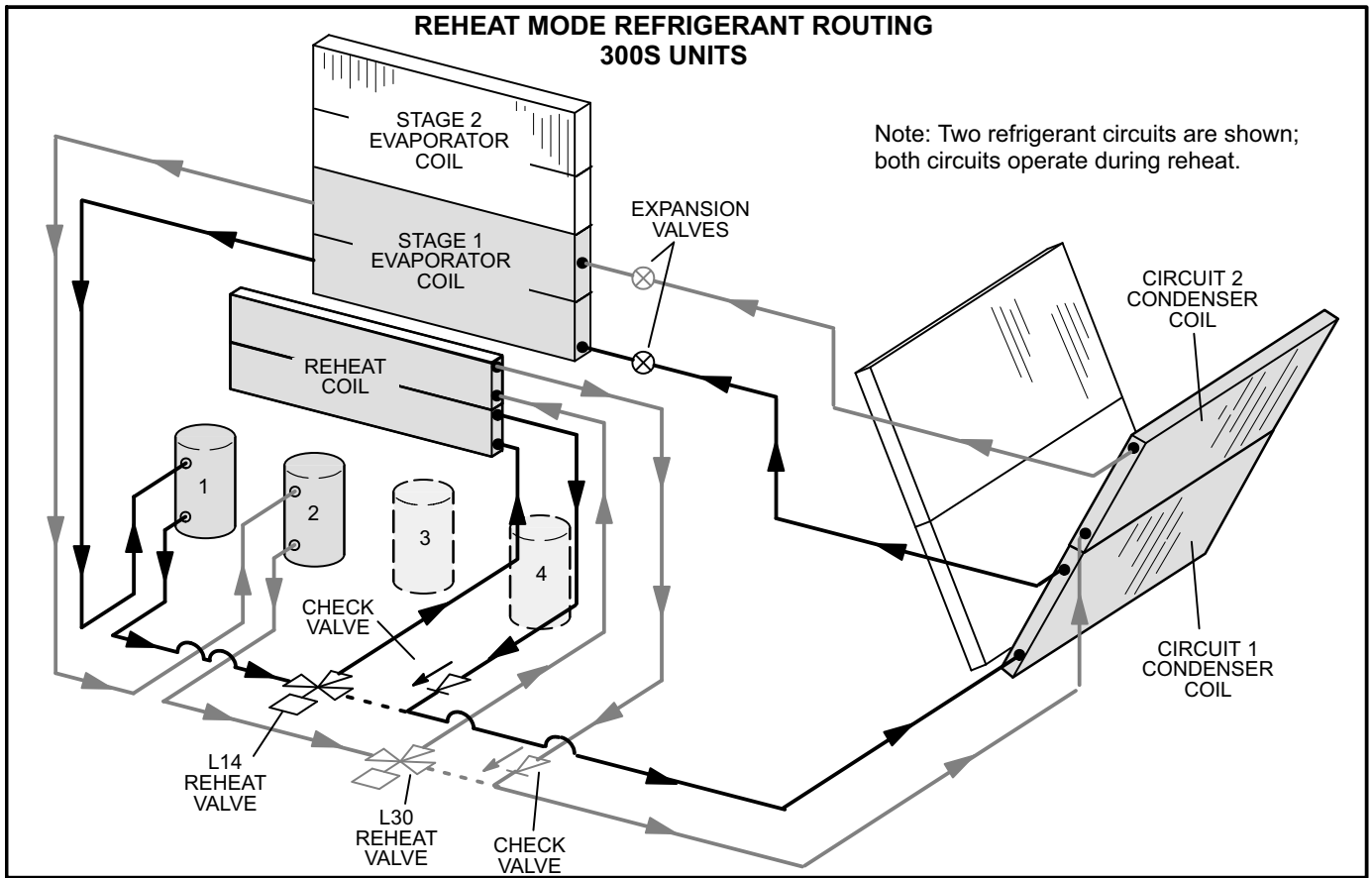


FIGURE 25

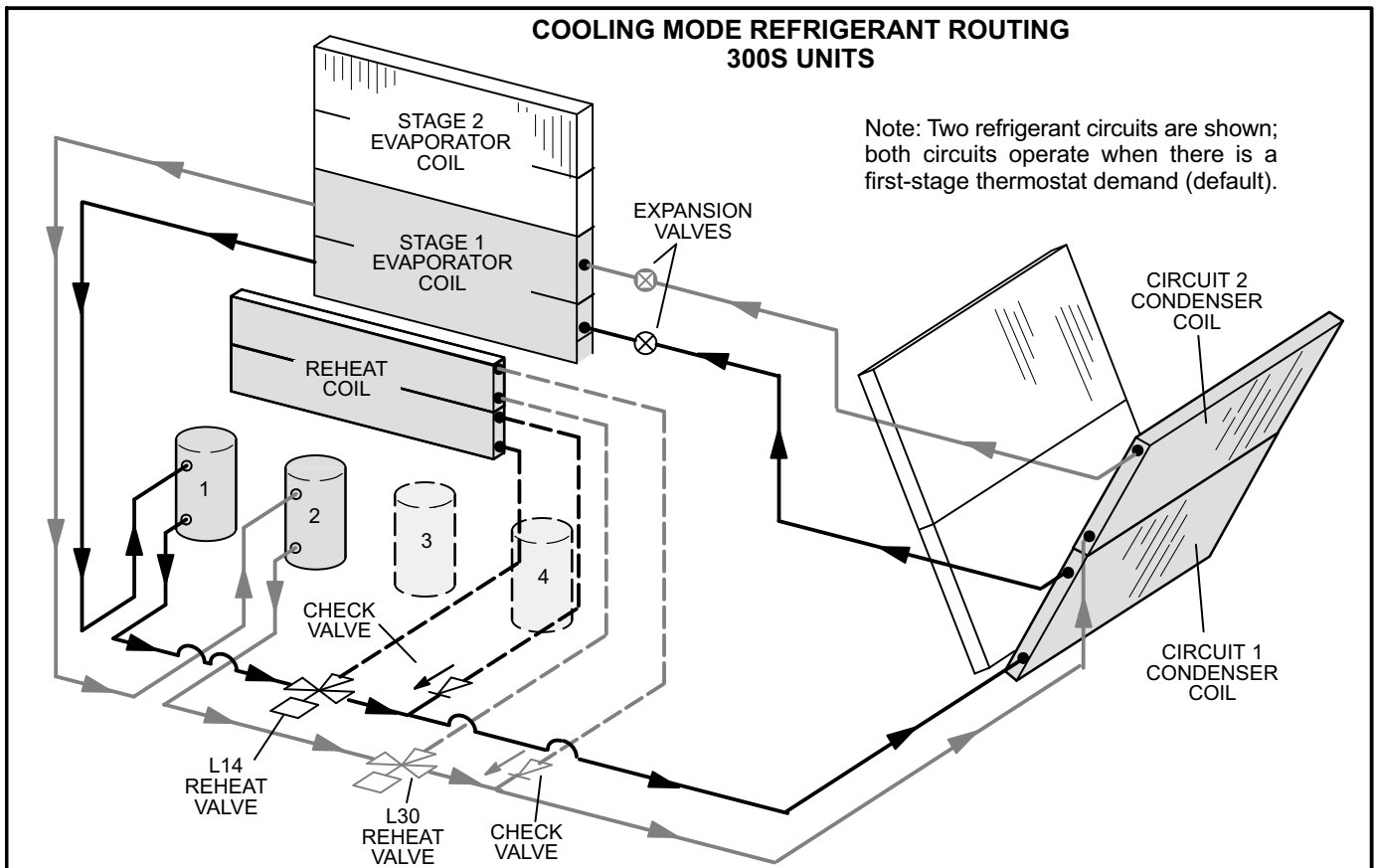


FIGURE 26

Service

The unit should be inspected once a year by a qualified service technician.

⚠ CAUTION

Label all wires prior to disconnection when servicing controls. Wiring errors can cause improper and dangerous operation. Verify proper operation after servicing.

A-Filters

Units are equipped with six 24 X 24 X 2" filters. Filters should be checked and replaced when necessary with filters of like kind and size. Take note of air flow direction marking on filter frame when reinstalling filters. See figure 27.

NOTE-Filters must be U.L.C. certified or equivalent for use in Canada.

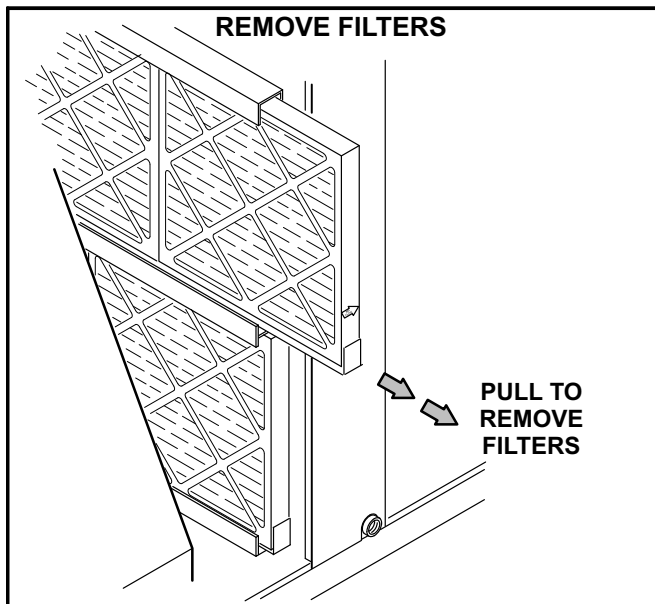


FIGURE 27

B-Lubrication

All motors are lubricated at the factory. No further lubrication is required.

Blower shaft bearings are prelubricated. For extended bearing life, relubricate at least once every two years with a lithium base grease such as Alvania 3 (Shell Oil), Chevron BRB2 (Standard Oil) or Regal AFB2 (Texas Oil). Use a hand grease gun for lubrication. Add only enough grease to purge through the bearings so that a bead of grease appears at the seal lip contacts.

C-Burners (Gas Units)

Periodically examine burner flames for proper appearance during the heating season. Before each heating season examine the burners for any deposits or blockage which may have occurred.

Clean burners as follows:

- 1- Turn off both electrical power and gas supply to unit.
- 2- Remove burner compartment access panel.
- 3- Remove screws securing burners to burner support and lift the individual burners or the entire burner assembly from the orifices. See figure 28. Clean as necessary.

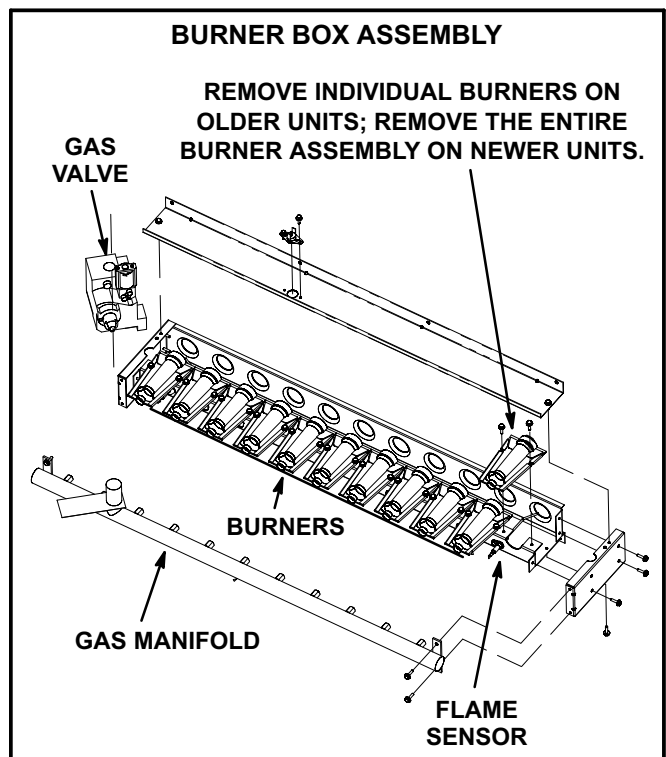


FIGURE 28

- 4- Locate the ignitor under the left burners. Check ignitor spark gap with appropriately sized twist drills or feeler gauges. See figure 29.
- 5- Check the alignment of the ignitor and the sensor as shown in figure 30 and table 20.
- 6- Replace burners and screws securing burner.

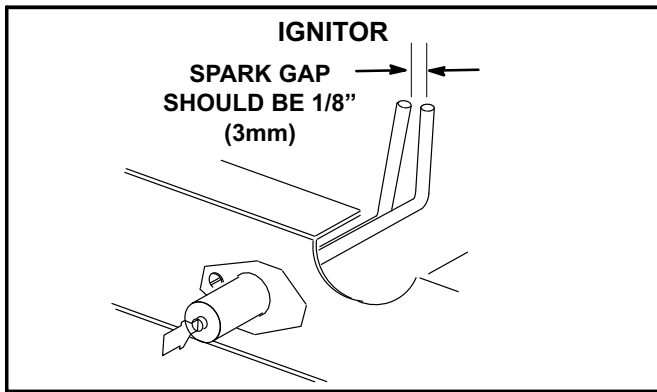


FIGURE 29

TABLE 20
IGNITOR AND SENSOR POSITION

Dimension	Unit Btuh Input	Length - in. (mm)	
		Ignitor	Sensor
A	260K	7-3/4 (197)	11 (279)
B	360K	5 (127)	5-1/2 (140)
C	480K	2-1/4 (57)	2-3/4 (70)

⚠ WARNING



Danger of explosion. Can cause injury or death. Do not overtighten main burner mounting screws. Snug tighten only.

7- Replace access panel.

8- Restore electrical power and gas supply. Follow lighting instructions attached to unit and use inspection port in access panel to check flame.

D-Combustion Air Inducer (Gas Units)

A combustion air proving switch checks combustion air inducer operation before allowing power to the gas controller. Gas controller will not operate if inducer is obstructed.

Under normal operating conditions, the combustion air inducer wheel should be checked and cleaned prior to the heating season. However, it should be examined periodically during the heating season to establish an ideal cleaning schedule. With power supply disconnected, the condition of the inducer wheel can be determined by looking through the vent opening.

Clean combustion air inducer as follows:

- 1- Shut off power supply and gas to unit.
- 2- Disconnect pressure switch air tubing from combustion air inducer port.
- 3- Remove and retain screws securing combustion air inducer to flue box. Remove and retain two screws from bracket supporting vent connector. See figure 31.

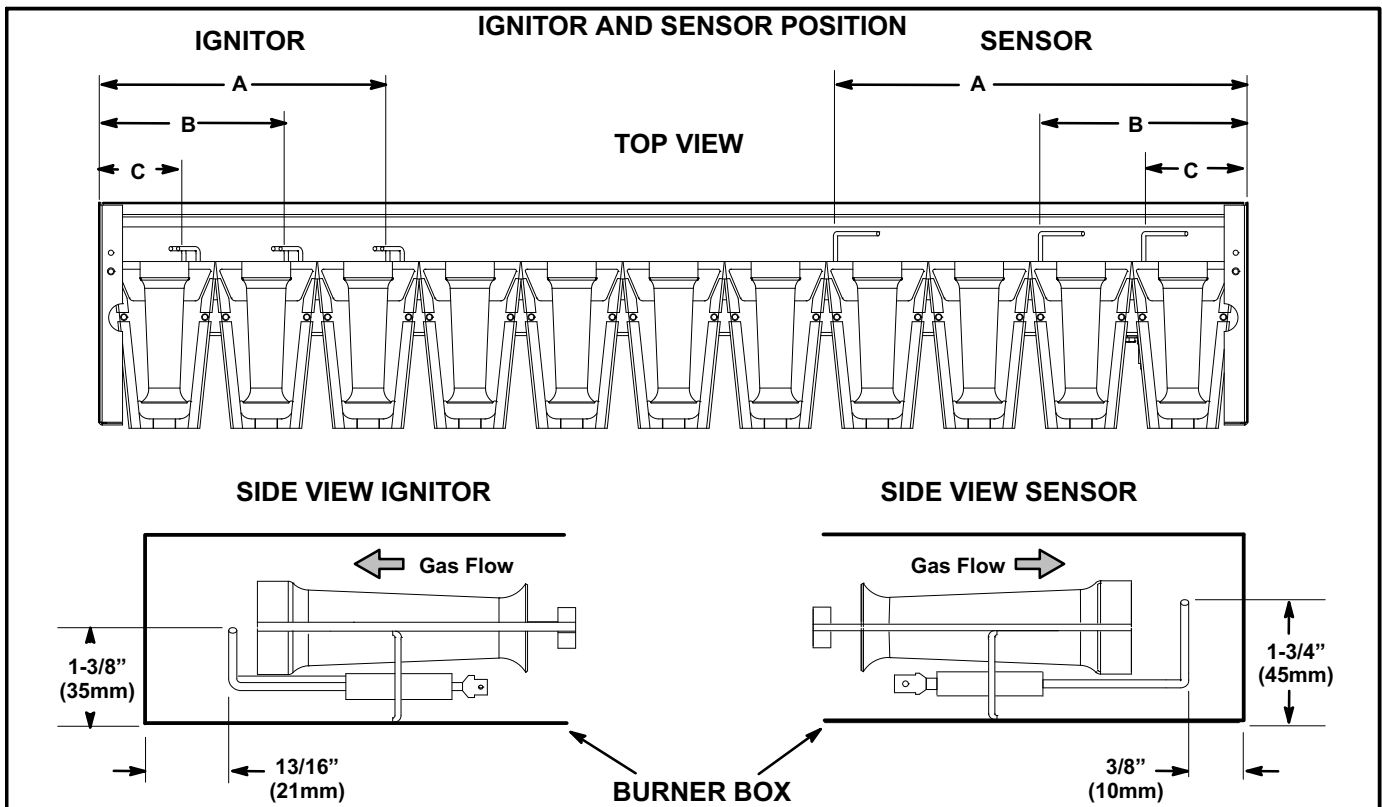


FIGURE 30

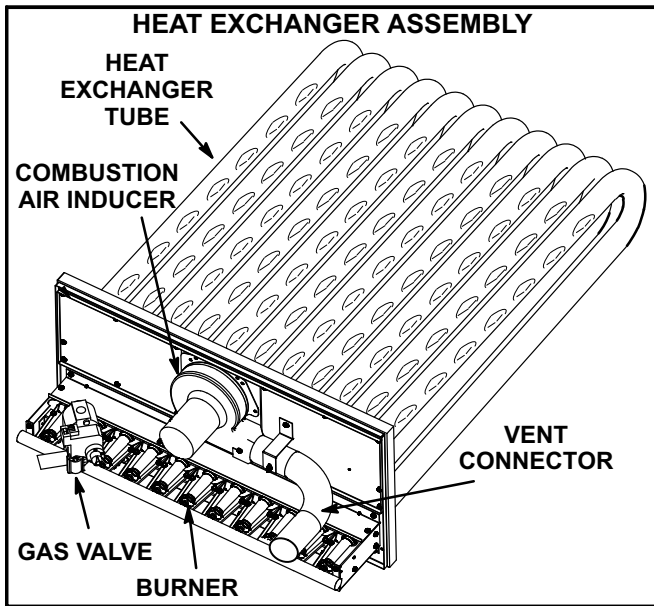


FIGURE 31

- 4- Clean inducer wheel blades with a small brush and wipe off any dust from housing. Clean accumulated dust from front of flue box cover.
- 5- Return combustion air inducer motor and vent connector to original location and secure with retained screws. It is recommended that the combustion air inducer gasket be replaced during reassembly.
- 6- Clean combustion air inlet louvers on heat access panel using a small brush.

E-Flue Passageway and Flue Box (Gas Units)

- 1- Remove combustion air inducer assembly as described in section D.
- 2- Remove flue box cover. Clean with a wire brush as required.
- 3- Clean tubes with a wire brush.
- 4- Reassemble the unit. The flue box cover gasket and combustion air inducer gasket should also be replaced during reassembly.

F-Evaporator Coil

Inspect and clean coil at beginning of each cooling season. Clean using mild detergent or commercial coil cleaner. Flush coil and condensate drain with water taking care not to get insulation, filters and return air ducts wet.

G-Condenser Coil

Clean condenser coil annually with water and inspect monthly during the cooling season.

Clean the coil by spraying the coil steadily and uniformly from top to bottom. Do not exceed 900 psi or a 45° angle; nozzle must be at least 12 inches from the coil face. Take care not to fracture the braze between the fins and refrigerant tubes. Reduce pressure and work cautiously to prevent damage.

H-Supply Air Blower Wheel

Annually inspect supply air blower wheel for accumulated dirt or dust. Turn off power before attempting to remove access panel or to clean blower wheel.

START-UP REPORT

Job Name: _____
 Store No. _____ Start-Up Date: _____
 Address: _____
 City: _____ State: _____
 Start-Up Contractor: _____
 Technician: _____
 Model No.: _____
 Serial No.: _____
 RTU No.: _____ Catalog No.: _____

Inspections and Checks			
Damage?	Yes	No	R22 <input type="checkbox"/> R410A <input type="checkbox"/>
If yes, reported to: _____			
Verify factory and field-installed accessories.			
Check electrical connections. Tighten if necessary.			
Supply voltage: L1-L2 _____ L1-L3 _____ L2-L3 _____			
If unit contains a 208-230/240 volt transformer:			
Check primary transformer tap <input type="checkbox"/>			
Transformer secondary voltage: _____			

Cooling Checks													
Compressor Rotation <input type="checkbox"/> Ambient Temp. _____ Return Air Temp. _____ Supply Air Temp. _____													
	Compressor Amps			Compressor Volts			Pressures		Condenser Fan Amps			CC Heater Amps	
	L1	L2	L3	L1-L2	L1-L3	L2-L3	Disch.	Suct.	L1	L2	L3	L1	
1													
2													
3													
4													

Blower Checks	
Pulley/Belt Alignment <input type="checkbox"/>	Blower Rotation <input type="checkbox"/>
Set Screws Tight <input type="checkbox"/>	Belt Tension <input type="checkbox"/>
Nameplate Amps: _____ Volts: _____	
Motor	Amps
	Volts
L1 _____	L1-L2 _____
L2 _____	L1-L3 _____
L3 _____	L2-L3 _____

Heating Checks - Electric							
Return Air Temp.: _____ Supply Air Temp.: _____							
Limits Operate: <input type="checkbox"/>							
	Amps						
	L1	L2	L3		L1	L2	L3
1				10			
2				11			
3				12			
4				13			
5				14			
6				15			
7				16			
8				17			
9				18			

Heating Checks - Gas		
Fuel type: Nat. <input type="checkbox"/> LP <input type="checkbox"/> Inlet Pressure: _____ in. w.c.		
Return Air Temp.: _____ Supply Air Temp.: _____		
Altitude: _____ Primary Limits Operate: <input type="checkbox"/>		
Gas Valve	Manifold Pressure	
	Low Fire	High Fire
GV1		
GV2		

Control Type

Accessory Checks	
Power Exhaust Amps	
1 _____	2 _____ None <input type="checkbox"/>
Economizer Operation	
Min. Pos. <input type="checkbox"/>	Motor travel full open/close <input type="checkbox"/>