

**INSTALLATION INSTRUCTIONS FOR ECONOMIZERS AND OUTDOOR AIR HOODS
USED WITH LG/LC/LH/LD 024, 036, 048, 060, 072, 074 UNITS**

Note - Disregard economizer installation section when dampers are factory-installed.

Shipping and Packing List

Package 1 of 1 contains:

- 1- Economizer damper assembly¹
- 1- GED² (gravity exhaust / barometric relief damper) assembly - hood top¹ covers the outdoor air opening and divider panel⁵ covers the exhaust air opening
- 1- Combination hood kit containing:³
 - 1-Hood top filter bracket
 - 2-Hood sides
 - 1-Bag containing screws
- 1- Filter kit containing:
 - 1-Filter⁴
 - 1-Pivot bracket
- Bag assembly containing:
 - 1-J18 harness
 - 1-Harness instruction

¹Already in place when economizer is factory-installed.
²GED is shipped and ordered separately for factory PEF units.
³Shipped in the return air section when economizer is factory-installed.
⁴Shipped in the blower section when economizer is factory-installed.
⁵The divider panel is shipped and ordered with the GED for factory PEF units.

Package 1 of 1 (ordered separately) contains:

Used in horizontal airflow applications only

- 1- Return air cover

Order Of Installation:

- Return air cover (horizontal airflow)*
- Economizer*
- Mixed air sensor (R1)*
- Remove GED (horizontal airflow and PEF options)*
- Optional OA/RA sensors*
- Power exhaust fans*
- GED seal in unit (PEF option)*
- GED in lower hood (horizontal and PEF options)*
- RA Transition (horizontal airflow)*
- RA duct (horizontal airflow)*
- Lower outdoor air hood*
- Upper outdoor air hood*

⚠ WARNING

Improper installation, adjustment, alteration, service or maintenance can cause property damage, personal injury or loss of life. Installation and service must be performed by a licensed professional HVAC installer or equivalent, service agency, or the gas supplier.

⚠ CAUTION

As with any mechanical equipment, contact with sharp sheet metal edges can result in personal injury. Take care while handling this equipment and wear gloves and protective clothing.

Application

The economizer is used with LG/LC/LH/LD units in downflow and horizontal air discharge applications. For horizontal air applications, use the separately shipped GEDH kit. See table 1. See table 2 for the optional gravity exhaust kit. The economizer uses outdoor air for free cooling when temperature and/or humidity is suitable. LG/LC/LH/LD units are equipped with the following factory-installed, CEC Title 24 approved sensors:

- RT17 - Outside Air Temperature
- RT16 - Return Air Temperature
- RT6 - Discharge Air Temperature

See figure 14 in the *Start-Up* section for sensor location. Optional field-provided sensors may be used instead of unit sensors to determine whether outdoor air is suitable for free cooling. Refer to table 3 in the *Start-Up* section.

**TABLE 1
Economizer**

Econ Type	Part No.*	
High Performance	20H48	609258-12

*Kits include GED and hoods.

⚠ WARNING

To prevent serious injury or death:

- 1- Lock-out/tag-out before performing maintenance.**
- 2- If system power is required (e.g., smoke detector maintenance), disable power to blower, remove fan belt where applicable, and ensure all controllers and thermostats are set to the "OFF" position before performing maintenance.**
- 3- Always keep hands, hair, clothing, jewelry, tools, etc., away from moving parts.**



TABLE 2
Gravity Exhaust Kit

Description	Part No.	
Used when power exhaust is factory-installed.	19D42	605993-04

Install Economizer - Downflow

- 1- Open unit end panel and filter access panel. See figure 1. When gravity or power exhaust are field-installed, remove and discard the lower panel.
- 2- Remove and retain sensors from mounting bracket. See figure 2. Remove mounting bracket and discard.
- 3- Remove hood top from economizer outdoor air opening and hood divider panel from economizer exhaust air opening.
- 4- Install damper assembly by inserting the damper motor first. See figure 3.
- 5- Fit opening in bottom of damper assembly over the return air opening. See figure 4.
- 6- Install retained sensors in the side of the economizer. See figure 4.
- 7- Connect economizer plug P4 to unit jack J3 hanging near the top of the filter section. See figure 5.
- 8- *Optional Power and Gravity Exhaust -* Locate J18 and J24 connectors bundled with J3. Insert connectors in openings shown in figure 5.

J18 Harness

Note - If J18 harness isn't hanging near the top of the filter access area, use the J18 harness provided with the filter kit. Follow instructions in the J18 harness bag assembly.

Note - If J18 is hanging near the top of the filter area AND J18 is installed in the side of the economizer, remove J18 from the side of the economizer. Insert J18 hanging near the top of the filter area.

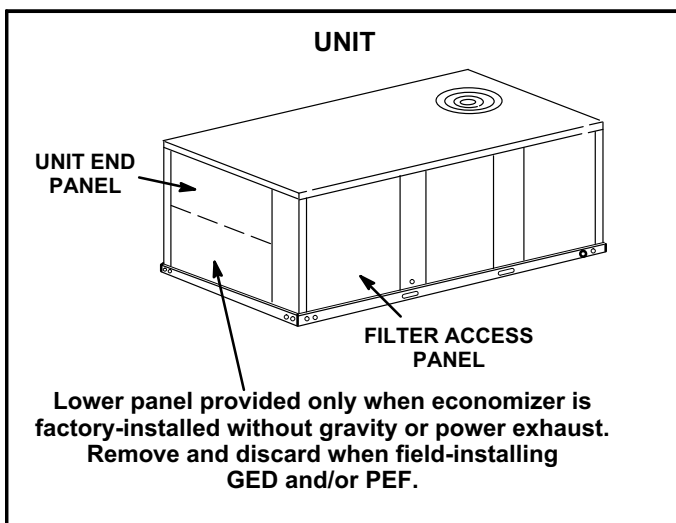

FIGURE 1

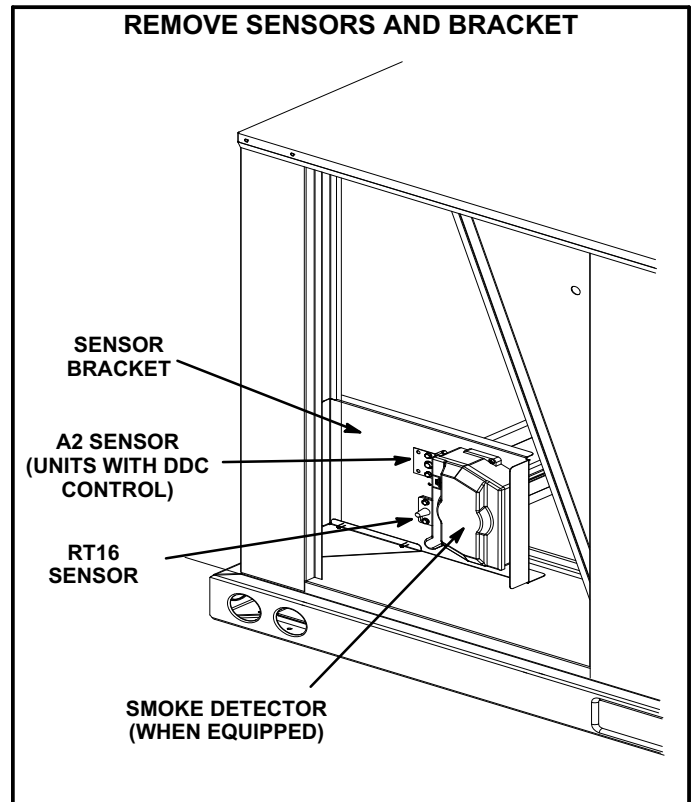

FIGURE 2

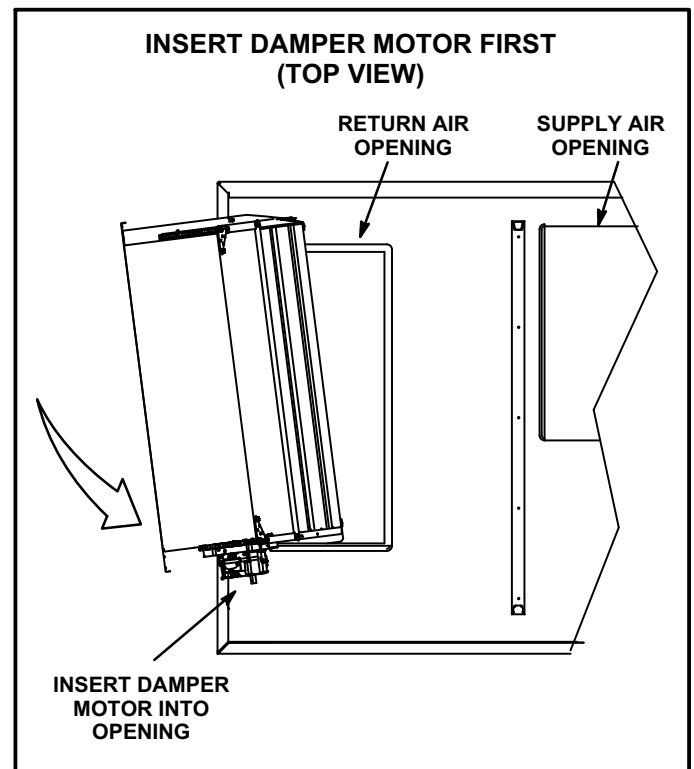

FIGURE 3

ECONOMIZER INSTALLATION

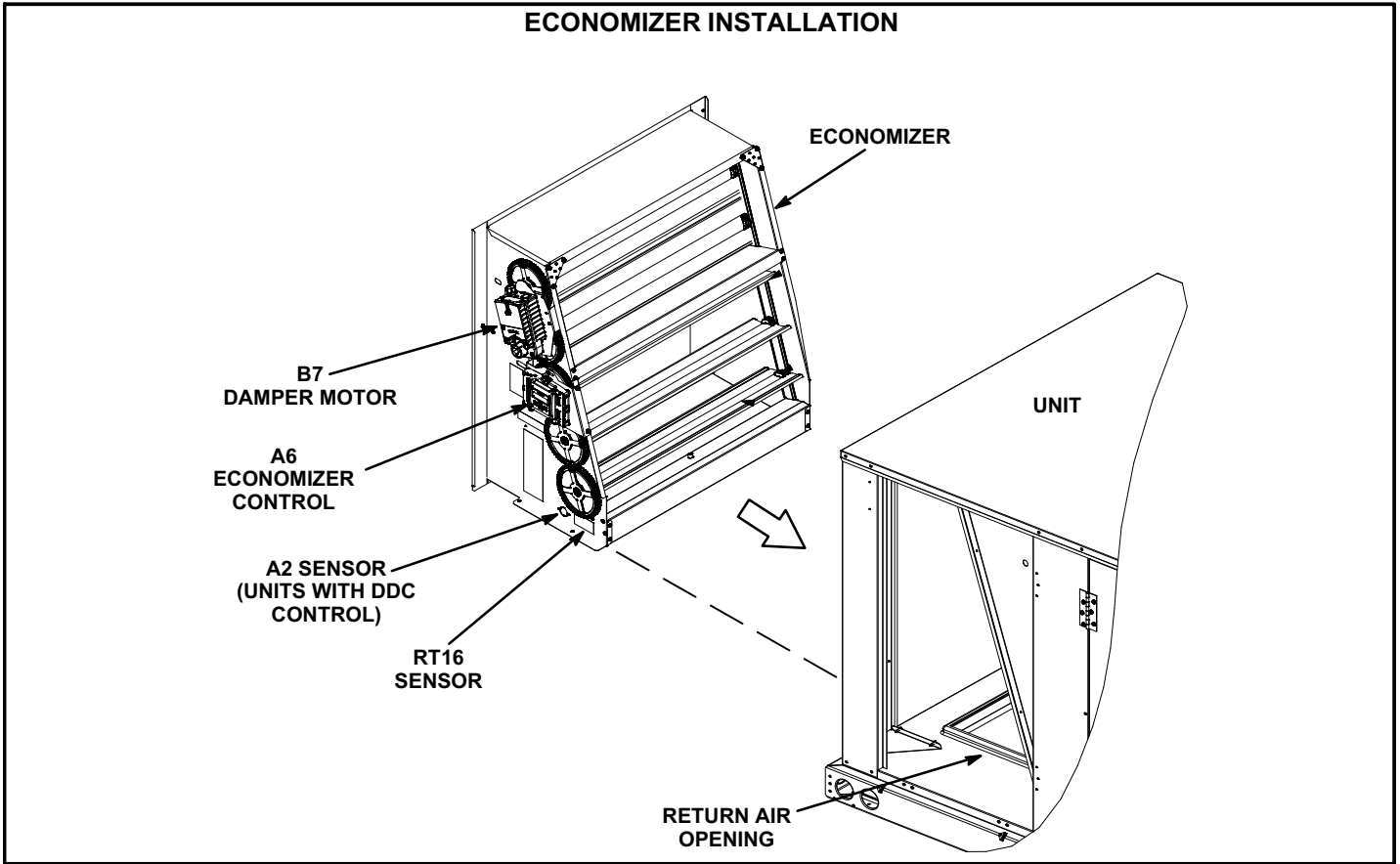

FIGURE 4

GED (Barometric Relief Dampers)

For horizontal airflow applications, a separately shipped GEDH gravity exhaust damper kit is required. Refer to instructions provided with GEDH kit.

Optional PEF

Factory-Installed PEF Only - Remove the PEF cover over the exhaust air opening before installing. A GED kit is packaged separately and shipped with the unit.

- 1- Remove GED from the economizer and install in the fresh / exhaust air hood when optional power exhaust fans are installed. See figure 6.
- 2- Install the power exhaust fans and GED seal in the unit. See figure 7. See the next section to install the outdoor/exhaust air hood. Install the GED in the lower/exhaust hood. See figure 9.

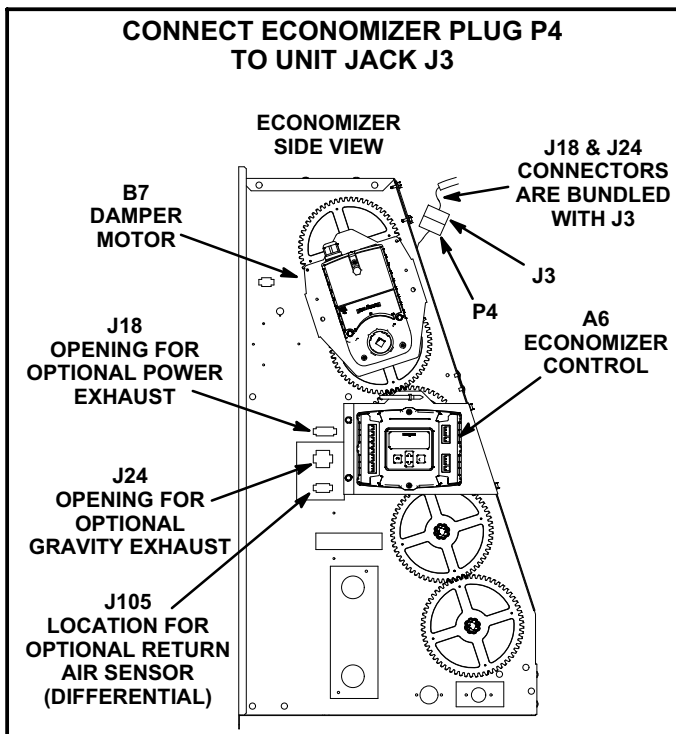

FIGURE 5

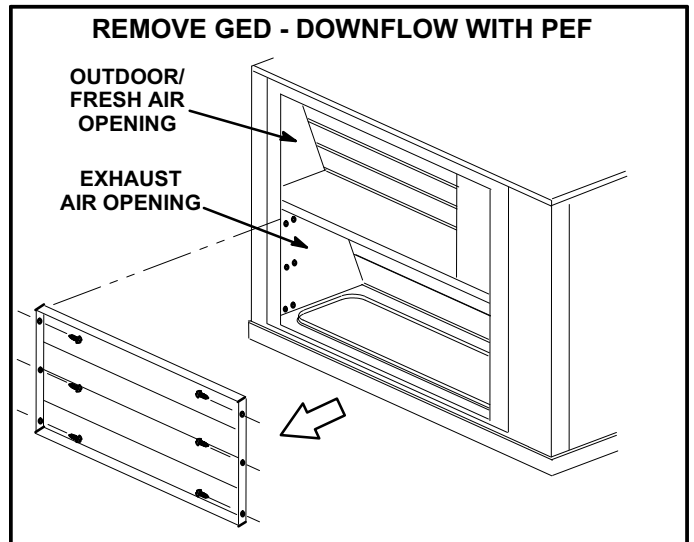

FIGURE 6

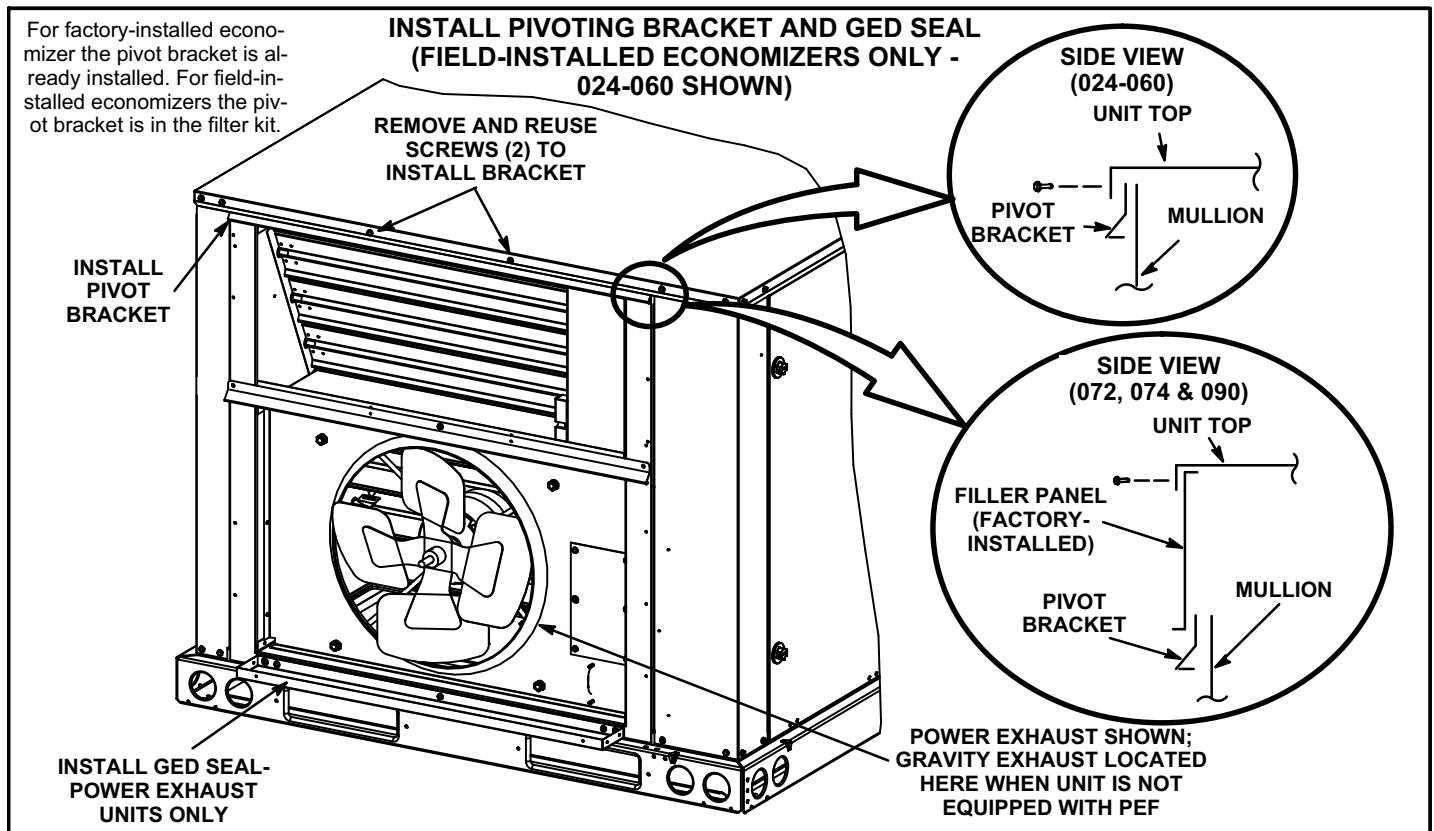

FIGURE 7

Outdoor Air Hoods - Downflow

Factory-Installed Economizers Only - The hood top and pivot bracket is installed over the unit fresh (outdoor) air opening. The hood divider panel is secured over the unit exhaust air opening. Hood sides and top filter bracket are located in the return air section. Lift hood top and divider panel and assemble hoods as described for field-installed economizers.

- 1- Make sure all sensors and outdoor air section accessories are installed before installing hoods.
- 2- Install pivot bracket as shown in figure 7.
- 3- Assemble hood as shown in figure 9. Slide top of hood into the ends of pivot bracket. Install top filter bracket after filter is in place.
- 4- Install hoods on unit.
- 5- Caulk ends of pivot bracket to seal watertight.

Install Economizer - Horizontal

A field-fabricated return air duct transition and duct inlet must be installed in horizontal applications.

- 1- Remove unit end panel. See figure 8.
- 2- Install the downflow return air cover in horizontal airflow applications. Secure with #10 sheet metal screws provided in kit. See figure 8.

- 3- Make sure the horizontal return air cover on the back side of the unit remains in place. The opening is used when an economizer is not installed. See figure 10.
- 4- Install the economizer and R1 mixed air sensor and connect wiring as shown in appropriately named sections of this manual.
- 5- Install the field-fabricated return air duct transition and duct inlet on the unit end. See figure 12. Support the transition and duct inlet as needed.
- 6- Install the lower (exhaust) hood on the return air duct as shown in the GEDH kit instruction.
- 7- Install the upper hood on the unit as shown in figure 11.

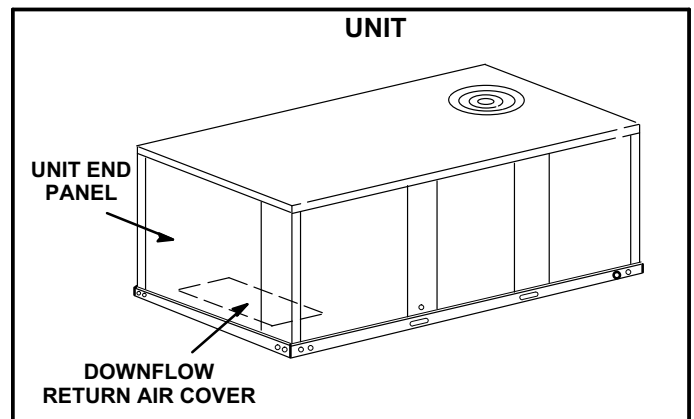

FIGURE 8

**ASSEMBLE HOODS DOWNFLOW AIR APPLICATIONS
(024-060 SHOWN)**

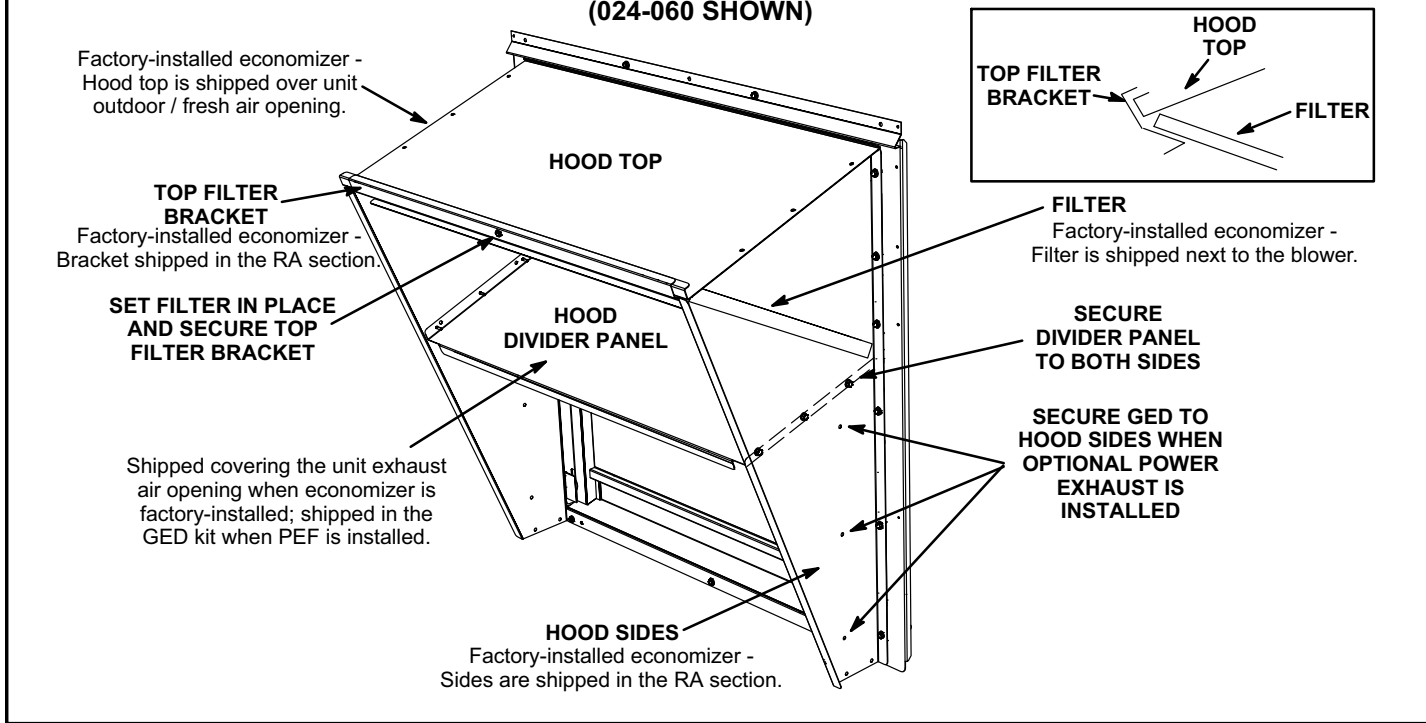

FIGURE 9

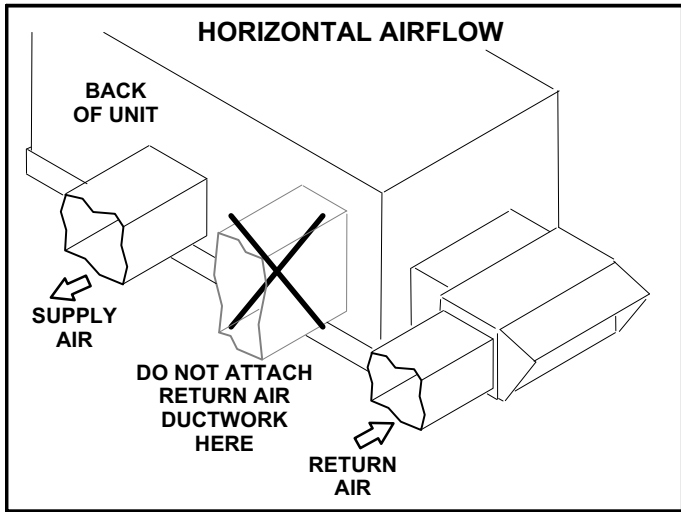

FIGURE 10

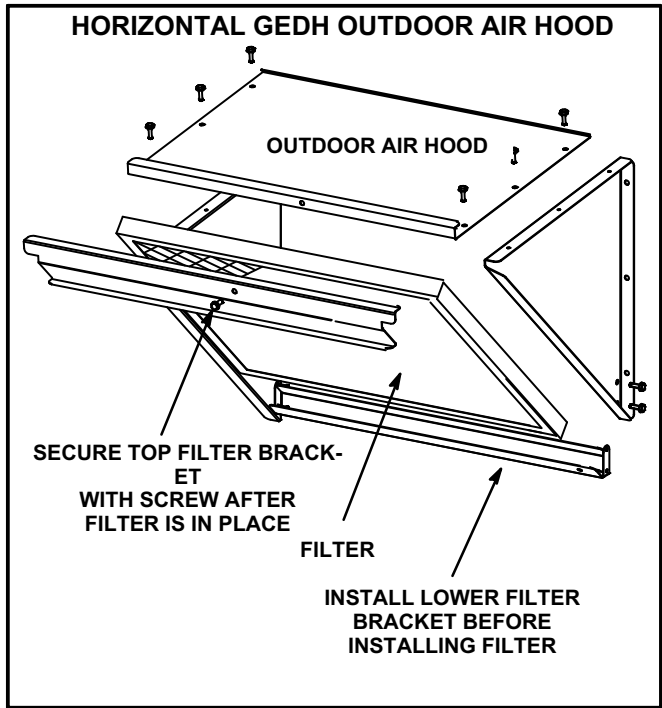

FIGURE 11

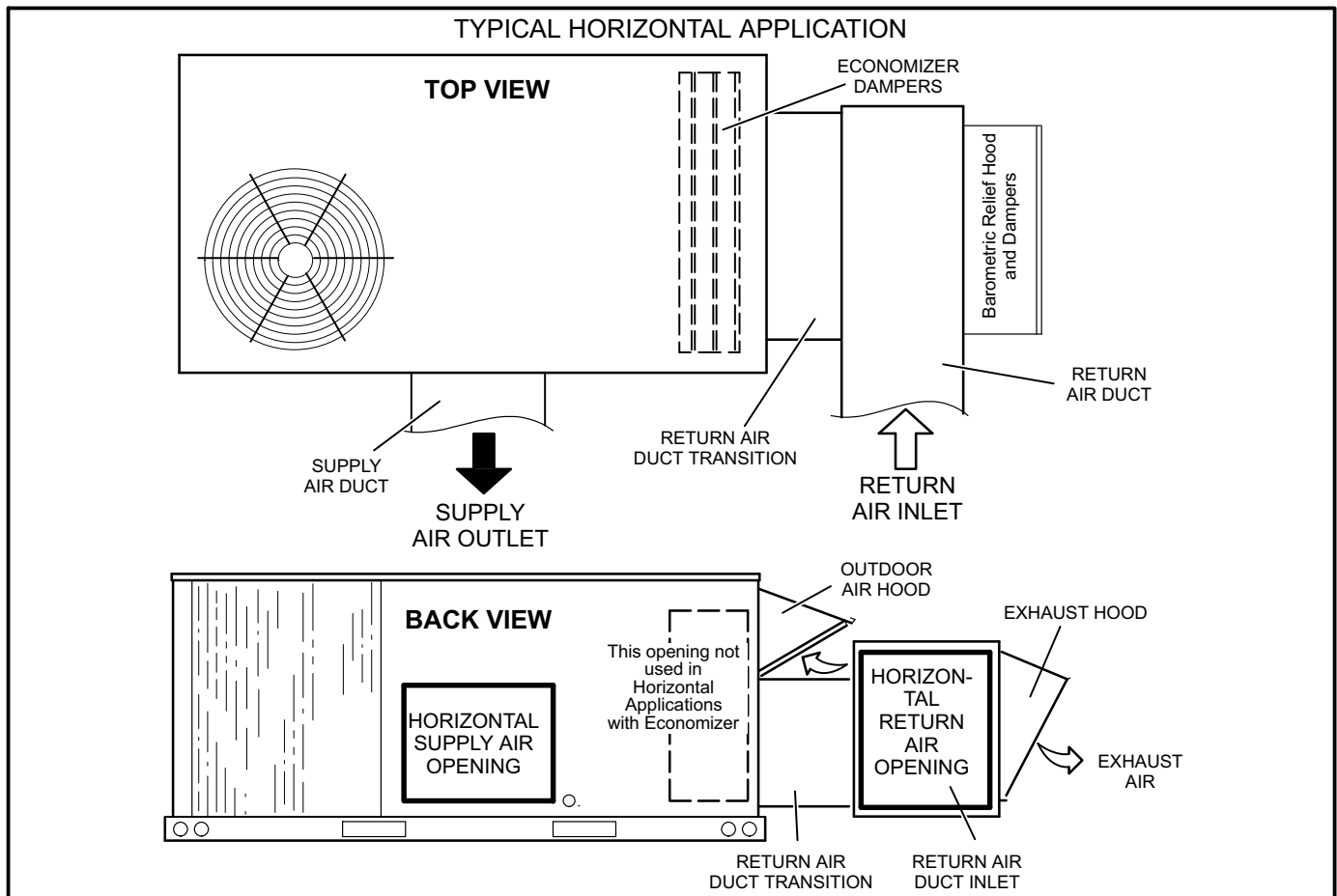

FIGURE 12

Economizer Start-Up - M2 Unit Controller

The unit will be equipped with either an M2, M3, or M4 Unit Controller. M2, M3, or M4 will be printed on the bottom of the Unit Controller near the SBUS connector or seven-segment display. Use the appropriate start-up section in this manual and refer to the Unit Controller provided with the rooftop unit. Application manuals are available for both Unit Controllers.

The economizer is controlled by the Unit Controller which is located in the unit control panel. A detailed menu layout can be found in the Unit Controller manual provided with each unit.

A-Field-Installed Economizer

The Unit Controller must be set to identify an economizer has been installed.

9- Use the Unit Controller keypad to enter the following menu:

Setting / Install / Damper

10- Use the up/down arrows to display ECON and press the SELECT button (!SET! will display).

11- Press the left arrow returning up the menu path until the Unit Controller resets and saves the change.

The Unit Controller will now operate the economizer.

B-Free Cooling Mode and Setpoint

On start-up, the economizer mode defaults to TEMP OFFSET. In this mode, free cooling is energized when the outdoor air temperature (RT17) is less than return air temperature (RT16) by at least the offset value. The default offset value is 10°F. Use the following menu path on the Unit Controller to adjust the free cooling mode or setpoint. See figure 14 for sensor location.

Settings / Setpoints / Damper / Economizer Mode

Refer to table 3 and figure 13 for additional free cooling modes and setpoints. The Unit Controller has a restricted range of input values for each mode as shown in table 3.

Note - An energy management system may be used to provide the outdoor air suitable (OAS) signal via network connection. The free cooling mode must be set to one of the TEMP modes to allow this function.

C-California Title 24 Compliance

For *California Title 24* compliance, adjust the free cooling setpoint based on:

- The climate zone where the unit is installed. See table 4.
- The setpoint requirement published by the California Energy Commission. See *Section 140.4 - Prescriptive Requirements for Space Conditioning Systems of the 2013 Building Energy Efficiency Standards*.

Note - Values in the referenced standard will supersede values listed in table 4.

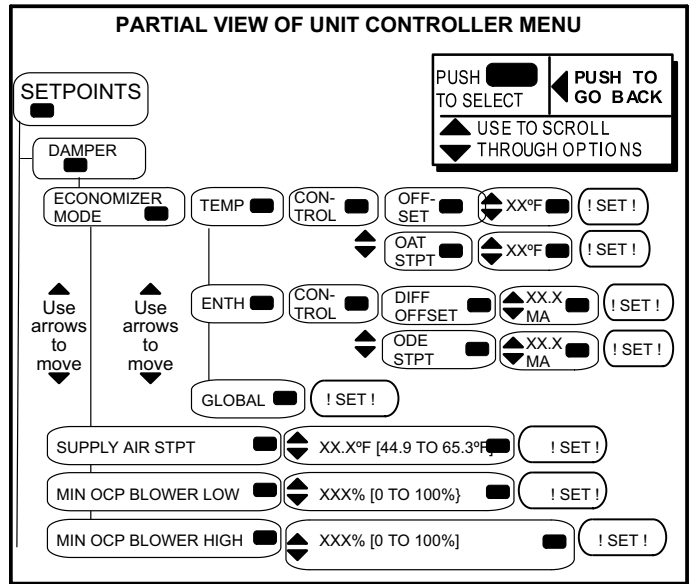

FIGURE 13

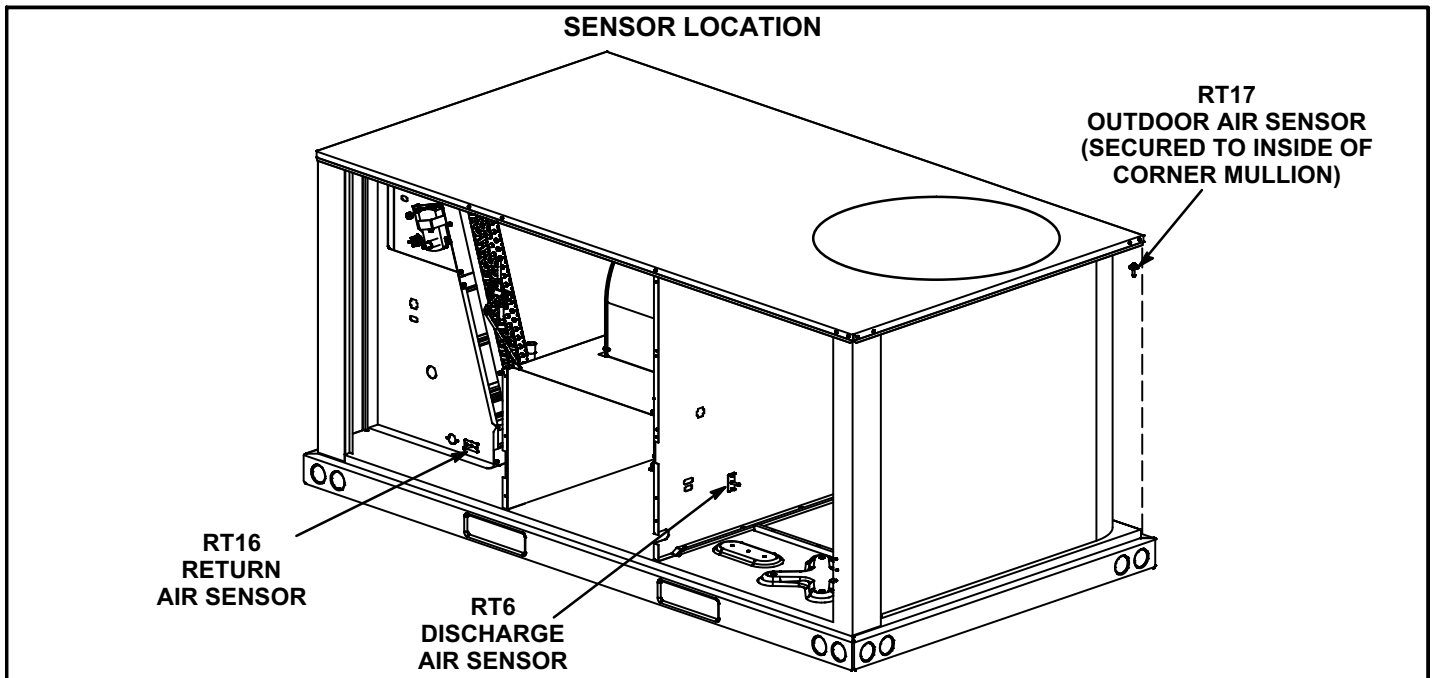

FIGURE 14

**TABLE 3
ECONOMIZER MODES AND SETPOINT**

Free Cooling Mode	Free Cooling Setpoint	Field-Provided Sensors	Dampers will modulate to 55°F discharge air (RT6) when outdoor air is suitable:	Permitted Inputs
TEMP	OFFSET	None Needed	Outdoor air temperature (RT17) is less than return air temperature (RT16) by at least the OFFSET value.	0-40°F
TEMP	OAT STPT	None Needed	Outdoor air temperature (RT17) is less than the OAT STPT value.	41-75°F
Remote	Remote	Energy Management System**	Either of the TEMP modes can be used when a network OAS signal is provided by an energy management or building control system, via BACnet, LonTalk, or L Connection. The network can command OAS, NOT OAS, or AUTO. AUTO returns to local control of OAS, which is the selected TEMP mode.	NA
ENTH	DIFF OFFSET	(Two) C7400	Outdoor air enthalpy* (A7) is less than return air enthalpy (A62) by at least the OFFSET value.	0mA-4mA
ENTH	ODE STPT	C7400	Outdoor air enthalpy (A7) is less than free cooling setpoint.	12-19mA
GLOBAL	GLOBAL	24VAC Input Signal	Global input is energized by (P297-9). This setting is also used for outdoor air damper applications. Global input also brings on the blower. (This mode is NOT used when OAS signal is provided via network connection. GLO is only used when a 24VAC signal is used to energize the P297-9 GLO input.)	NA

*Enthalpy includes effects of both temperature and humidity.

**Energy management system may require additional field-provided sensors; refer to manufacturer's instructions.

**TABLE 4
FREE COOLING SETPOINT**

Climate Zone	Setpoint (Single Sensible)	Setpoint (Differential Sensible)
1, 3, 5, 11-16	75°F	0°F
2, 4, 10	73°F	2°F
6, 8, 9	71°F	4°F
7	69°F	6°F

D-Setting Free Cooling Setpoint in Enthalpy Mode

Free Cooling Setpoint - ODE STPT

The enthalpy sensor (A7) provides a milliamp signal to the Unit Controller based on outdoor air temperature and humidity. See table 5. To set a free cooling setpoint of 73°F at 50% relative humidity, enter "12" at the ODE STPT menu prompt. The Unit Controller will allow dampers to modulate open at approximately 73°F. If the space temperature is too warm, change the ODE STPT to "13.6" and the Unit Controller will allow dampers to modulate open at approximately 70°F.

**TABLE 5
FREE COOLING SETPOINT - ODE STPT MODE**

Enthalpy Setpoint °F (°C)*	Menu Entry - mA	Counts
73 (23)	12.0	150
70 (21)	13.6	173
67 (19)	15.5	199
63 (17)	17.6	224

*Approximate temperature at 50% relative humidity.

Free Cooling Differential Enthalpy - DIFF OFFSET

The Unit Controller allows damper modulation when outdoor air is lower than return air by a differential or offset temperature and humidity range. To set an offset range of 7°F at a constant relative humidity, enter "4" at the DIFF OFFSET menu prompt. If return air is 76°F, the Unit Controller will allow damper to modulate open at approximately 69°F outdoor air. See table 6. If the space temperature is too cool or dry, change the DIFF OFFSET to "3" and the Unit Controller will allow dampers to modulate open at approximately 71°F outdoor air.

**TABLE 6
FREE COOLING SETPOINT - DIFF OFFSET MODE**

*Temperature Offset °F	**Relative Humidity Offset %	Menu Entry mA	Counts
2	6	1	13
3.5	12	2	26
5.3	18	3	39
7	24	4	53

*At a constant relative humidity. **At a constant temperature.

E-Damper Minimum Position Setting

Use the menu path in figure 13 to set the minimum % open damper position when outdoor air is not suitable for free cooling. The minimum setpoint range is 0% open (dampers closed) to 100% (dampers fully open). On units equipped with a ventilation control board, refer to the VCB Start-Up section in the installation instructions provided with each unit.

**TABLE 7
FREE COOLING OPTIONS**

Config. ID1 (POS 2)	Unit Controller Input (Mode)	M3 Display (Free Cooling Options)	Default Setting	Range Setting	Outdoor air is suitable for free cooling when:
T	Differential Sensible Sensor (default mode)	ECONOMIZER TEMP ECON TYPE = TEMPERATURE OFFSET	10°F	0°F - 40°F	Outdoor air temperature (RT17) is less than return air temperature (RT16) by at least the offset value.
T	Single Sensible Sensor	ECONOMIZER TEMP ECON TYPE = TEMPERATURE SETPOINT	75°F	40 F - 75 F	Outdoor air temperature (RT17) is less than the Outdoor Air Temperature set point value.
T	Network OAS	ECONOMIZER TEMP ECON TYPE = TEMPER- ATURE OFFSET or SETPOINT	Not Applicable	Not Applicable	Either of the TEMP modes (set point or offset) can be used when a network OAS signal is provided by an energy management or building control system, via BACnet, LonTalk, or L Connection. The network can command OAS, NOT OAS, or AUTO. AUTO returns to local control of OAS, which is the selected TEMP mode.
S	Single Enthalpy* Sensor	ECONOMIZER ENTHALPY SETPOINT = 12.0 MA	12.0 mA	10mA - 19 mA	Outdoor air enthalpy (A7) is less than enthalpy set point parameter.
D	Differential Enthalpy* Sensor	ECONOMIZER ENTHALPY OFFSET = 1.0 MA	1.0 mA	1 mA - 5 mA	Outdoor air enthalpy* (A7) is less than return air enthalpy (A62) by at least the OFFSET value.
G	Global	Mode and setpoint are not set by Unit Controller. Menu advances to: FREE COOLING SUPPLY AIR SETPOINT = 55°F	Not Applicable	Not Applicable	Global input is energized by (P297-9). This setting is also used for outdoor air damper applications. Global input also brings on the blower. (This mode is NOT used when OAS signal is provided via network connection. GLO is only used when a 24VAC signal is used to energize the P297-9 GLO input.)

*Enthalpy includes effects of both temperature and humidity.

Economizer Start-Up - M3 Unit Controller

The unit will be equipped with either an M2 or M3 Unit Controller. M2 or M3 will be printed on the bottom of the Unit Controller near the SBUS connector. Use the appropriate start-up section in this manual and refer to the Unit Controller provided with the rooftop unit. Application manuals are available for both Unit Controllers.

The economizer is controlled by the Unit Controller which is located on the unit control panel. A detailed menu layout can be found in the Unit Controller manual provided with each unit.

A-Field-Installed Economizer

The Unit Controller must be set to identify an economizer has been installed. The configuration ID will also identify which sensor inputs the Unit Controller will use to determine the free cooling mode. See figure 14 for sensor location.

- 1- Use the Unit Controller keypad to enter the following menu:
MAIN MENU > SETUP > INSTALL
- 2- Press SAVE until CONFIGURATION ID 1 appears. Change the second character in the configuration ID to identify the type of input used to determine economizer free cooling setpoint. See table 7.
- 3- Press SAVE. The Unit Controller is now set up to operate the economizer.
- 4- Press the MAIN MENU button, then the BACK button, to display the status screen.

B-Adjust Free Cooling Discharge Air Setpoint

When outdoor air is suitable for free cooling, dampers will modulate to maintain a discharge air temperature of 55°F default (adjustable range 45°-67°F). Refer to RT6 discharge air sensor location shown in figure 14.

C-Free Cooling Modes

The Unit Controller automatically sets the free cooling mode when the configuration ID is entered. The temperature setpoint mode is the only exception.

- 1- Use the following menu path on the Unit Controller to enter the temperature setpoint mode.

MAIN MENU > SETTINGS > RTU OPTIONS > DAMPER > ECONOMIZER TEMP ECON TYPE = TEMPERATURE OFFSET (default)

- 2- Use the “Adjust and set values” arrows on the keypad to select TEMPERATURE SETPT.
- 3- Press SAVE.

Note - Network OAS signal and California Title 24 Compliance options use either TEMPERATURE OFFSET or TEMPERATURE SETPT mode.

D-Adjust Outdoor Air Free Cooling Setpoint

Note - Configuration ID 1 must be set to the appropriate mode before adjusting the free cooling setpoint. See table 7

Temperature Offset or Temperature Setpoint Mode

- 1- After the free cooling mode is saved, if default setpoint value needs to change, enter the new number and press SAVE.
- 2- For *California Title 24* compliance, adjust the free cooling setpoint based on:
 - The climate zone where the unit is installed. See table 4.
 - The setpoint requirement published by the California Energy Commission. See *Section 140.4 - Prescriptive Requirements for Space Conditioning Systems of the 2013 Building Energy Efficiency Standards.*

Note - Values in the referenced standard will supersede values listed in table 4.

- 3- When a network OAS signal is provided by a building control system, refer to control system literature to adjust free cooling setpoint.

Enthalpy Setpoint

The enthalpy sensor (A7) provides a milliamp signal to the Unit Controller based on outdoor air temperature and humidity. Use the following menu to change the setpoint:

MAIN MENU > SETTINGS > RTU OPTIONS > DAMPER > ECONOMIZER ENTHALPY SETPOINT = 12.0 MA

Refer to table 5. At 12.0mA, the Unit Controller will allow dampers to modulate open at approximately 73°F. If the space temperature is too warm or humid, change the ECONOMIZER ENTHALPY SETPOINT to “13.6MA” and the Unit Controller will allow dampers to modulate open at approximately 70°F.

Enthalpy Offset

The Unit Controller allows damper modulation when outdoor air is lower than return air by a differential or offset temperature and humidity range. Use the following menu to change the setpoint:

MAIN MENU > SETTINGS > RTU OPTIONS > DAMPER > ECONOMIZER ENTHALPY OFFSET = 1.0 MA

Refer to table 6. At 1.0mA, the Unit Controller will allow dampers to modulate open when outdoor air is lower than return air by approximately a 2°F offset. If return air is 76°F, the Unit Controller will allow dampers to modulate open at approximately 74°F. If the space temperature is too warm or humid, change the ECONOMIZER ENTHALPY SETPOINT to 2.0mA or an offset of 3.5°F. The Unit Controller will allow dampers to modulate open at approximately 72.5°F.

E-Damper Minimum Position Setting

Use the menu path in table 8 to set the MIN DAMPER POSITION BLOWER ON HIGH when outdoor air is not suitable for free cooling. The minimum setpoint range is 0% open (dampers closed) to 100% (dampers fully open). On units with staged supply air blowers, also set the MIN DAMPER POSITION BLOWER ON LOW.

**TABLE 8
DAMPER OPTIONS**

Level 2	Level 3	Level 4	Level 5
RTU OP- TION	DAMPER	ECONOMIZER ENTHALPY OFFSET = 12.0 MA	
		ECONOMIZER ENTHALPY SETPOINT = 1.0 MA	
		ECONOMIZER TEMP ECON TYPE = TEMPERATURE OFFSET OR TEMPERATURE SETPT	
		ECONOMIZER OAT SETPOINT = XX.X F	
		FREE COOLING SUPPLY AIR SETPOINT = 55°F	
		MIN DAMPER POSITION BLOWER ON HIGH = X.X %	
		MIN DAMPER POSITION BLOWER ON LOW = X.X %	

Note - Menu options vary depending on hardware configuration.

Note - Use the “Adjust and set values” arrows to scroll up or down for selection options.

**TABLE 9
FREE COOLING OPTIONS**

Config. ID1 (POS 2)	Unit Controller Input (Mode)	M4 Display (Free Cooling Options)	Default Setting	Range Setting	Outdoor air is suitable for free cooling when:
T	Differential Sensible Sensor (default mode)	ECONOMIZER TEMP ECON TYPE = TEMPERATURE OFFSET	10°F	0°F - 40°F	Outdoor air temperature (RT17) is less than return air temperature (RT16) by at least the offset value.
T	Single Sensible Sensor	ECONOMIZER TEMP ECON TYPE = TEMPERATURE SETPOINT	75°F	40 F - 75 F	Outdoor air temperature (RT17) is less than the Outdoor Air Temperature set point value.
T	Network OAS	ECONOMIZER TEMP ECON TYPE = TEMPER- ATURE OFFSET or SETPOINT	Not Applicable	Not Applicable	Either of the TEMP modes (set point or offset) can be used when a network OAS signal is provided by an energy management or building control system, via BACnet, LonTalk, or L Connection. The network can command OAS, NOT OAS, or AUTO. AUTO returns to local control of OAS, which is the selected TEMP mode.
S	Single Enthalpy* Sensor	ECONOMIZER ENTHALPY SETPOINT = 12.0 MA	12.0 mA	10mA - 19 mA	Outdoor air enthalpy (A7) is less than enthalpy set point parameter.
D	Differential Enthalpy* Sensor	ECONOMIZER ENTHALPY OFFSET = 1.0 MA	1.0 mA	1 mA - 5 mA	Outdoor air enthalpy* (A7) is less than return air enthalpy (A62) by at least the OFFSET value.
G	Global	Mode and setpoint are not set by Unit Controller. Menu advances to: FREE COOLING SUPPLY AIR SETPOINT = 55°F	Not Applicable	Not Applicable	Global input is energized by (P297-9). This setting is also used for outdoor air damper applications. Global input also brings on the blower. (This mode is NOT used when OAS signal is provided via network connection. GLO is only used when a 24VAC signal is used to energize the P297-9 GLO input.)

*Enthalpy includes effects of both temperature and humidity.

Economizer Start-Up - M4 Unit Controller

The unit will be equipped with either an M2, M3, or M4 Unit Controller. M2, M3, or M4 will be printed on the bottom of the Unit Controller. M2 or M3 will be near the SBUS connector and M4 will be near the LED display. Use the appropriate start-up section in this manual and refer to the Unit Controller provided with the rooftop unit. Application manuals are available for all Unit Controllers.

The economizer is controlled by the Unit Controller which is located on the unit control panel. A detailed menu layout can be found in the Unit Controller manual provided with each unit.

A-Field-Installed Economizer

The Unit Controller must be set to identify an economizer has been installed. The configuration ID will also identify which sensor inputs the Unit Controller will use to determine the free cooling mode. See figure 14 for sensor location.

- 1- Use the Unit Controller mobile application to enter the following menu:

RTU MENU > SETUP INSTALL

- 2- Navigate through various setup questions until CONFIGURATION ID 1 appears. Change the second character in the configuration ID to identify the type of input used to determine economizer free cooling setpoint. See table 9.
- 3- Continue through the setup until complete.

Note - Refer to the Setup Guide provided with the unit for Unit Controller details.

B-Adjust Free Cooling Discharge Air Setpoint

When outdoor air is suitable for free cooling, dampers will modulate to maintain a discharge air temperature of 55°F default (adjustable range 45°-67°F). Refer to RT6 discharge air sensor location shown in figure 14.

C-Free Cooling Modes

The Unit Controller automatically sets the free cooling mode when the configuration ID is entered. The temperature setpoint mode is the only exception.

- 1- Use the following menu path in the mobile application to enter the temperature setpoint mode.

RTU MENU > SETTINGS RTU OPTIONS > DAMPER > ECONOMIZER TEMP ECON TYPE = TEMPERATURE OFFSET (default)

- 2- Use the +/- buttons to select TEMPERATURE OFFSET/SETPOINT.
- 3- Continue through the setup.

Note - Network OAS signal and California Title 24 Compliance options use either TEMPERATURE OFFSET or TEMPERATURE SETPT mode.

D-Adjust Outdoor Air Free Cooling Setpoint

Note - Configuration ID 1 must be set to the appropriate mode before adjusting the free cooling setpoint. See table 9.

Temperature Offset or Temperature Setpoint Mode

- 1- After the free cooling mode is saved, press NEXT. If default setpoint value needs to change, enter the new number and press NEXT.
- 2- For *California Title 24* compliance, adjust the free cooling setpoint based on:
 - The climate zone where the unit is installed. See table 4.
 - The setpoint requirement published by the California Energy Commission. See *Section 140.4 - Prescriptive Requirements for Space Conditioning Systems of the 2013 Building Energy Efficiency Standards*.

Note - Values in the referenced standard will supersede values listed in table 4.

- 3- When a network OAS signal is provided by a building control system, refer to control system literature to adjust free cooling setpoint.

Enthalpy Setpoint

The enthalpy sensor (A7) provides a milliamp signal to the Unit Controller based on outdoor air temperature and humidity. Use the following menu to change the setpoint:

RTU MENU > SETTINGS RTU OPTIONS > DAMPER > ECONOMIZER ENTHALPY SETPOINT = 12.0 MA

Refer to table 5. At 12.0mA, the Unit Controller will allow dampers to modulate open at approximately 73°F. If the space temperature is too warm or humid, change the ECONOMIZER ENTHALPY SETPOINT to “13.6MA” and the Unit Controller will allow dampers to modulate open at approximately 70°F.

Enthalpy Offset

The Unit Controller allows damper modulation when outdoor air is lower than return air by a differential or offset temperature and humidity range. Use the following menu to change the setpoint:

RTU MENU > SETTINGS RTU OPTIONS > DAMPER > ECONOMIZER ENTHALPY OFFSET = 1.0 MA

Refer to table 6. At 1.0mA, the Unit Controller will allow dampers to modulate open when outdoor air is lower than return air by approximately a 2°F offset. If return air is 76°F, the Unit Controller will allow dampers to modulate open at approximately 74°F. If the space temperature is too warm or humid, change the ECONOMIZER ENTHALPY SETPOINT to 2.0mA or an offset of 3.5°F. The Unit Controller will allow dampers to modulate open at approximately 72.5°F.

E-Damper Minimum Position Setting

Use the menu path in table 10 to set the MIN DAMPER POSITION BLOWER ON HIGH when outdoor air is not suitable for free cooling. The minimum setpoint range is 0% open (dampers closed) to 100% (dampers fully open). On units with staged supply air blowers, also set the MIN DAMPER POSITION BLOWER ON LOW.

**TABLE 10
DAMPER OPTIONS**

Level 2	Level 3	Level 4	Level 5
RTU OP- TION	DAMPER	ECONOMIZER ENTHALPY OFFSET = 12.0 MA	
		ECONOMIZER ENTHALPY SETPOINT = 1.0 MA	
		ECONOMIZER TEMP ECON TYPE = TEMPERATURE OFFSET OR TEMPERATURE SETPT	
		ECONOMIZER OAT SETPOINT = XX.X F	
		FREE COOLING SUPPLY AIR SETPOINT = 55°F	
		MIN DAMPER POSITION BLOWER ON HIGH = X.X %	
		MIN DAMPER POSITION BLOWER ON LOW = X.X %	

Note - Menu options vary depending on hardware configuration.

Note - Use the “Adjust and set values” arrows to scroll up or down for selection options.