

⚠ WARNING

Improper installation, adjustment, alteration, service or maintenance can cause property damage, personal injury or loss of life. Installation and service must be performed by a licensed professional HVAC installer or equivalent, service agency, or the gas supplier

Table of Contents

Dimensions	Page 2
Parts Arrangements	Page 4
Shipping and Packing List	Page 5
General	Page 5
Unit Support	Page 5
Duct Connection	Page 6
Rigging Unit For Lifting	Page 7
Shipping Blocks	Page 7
Reverse Condensate Drains	Page 10
Condensate Drains	Page 11
Connect Gas Piping	Page 11
Pressure Test Gas Piping	Page 11
Flue and Intake Hoods	Page 12
High Altitude Derate	Page 12
Electrical Connections	Page 13
Multi-Staged Air Volume Start-Up	Page 16
Variable Air Volume Start-Up	Page 18
Blower Operation and Adjustments	Page 19
Cooling Start-Up	Page 32
Gas HeatStart-Up	Page 36
Gas Heat Operation and Adjustment	Page 37
Electric Heat Start-Up	Page 37

INSTALLATION INSTRUCTIONS

LGH420, 480, 540, 600 LCH420, 480, 540, 600

(35, 40, 45, & 50 Ton)

GAS AND COOLING PACKAGED UNITS

507232-04
4/2020
Supersedes 7/2018

⚠ IMPORTANT

Supply air VFD motor rotation is controlled independently from scroll compressor rotation. See Cooling Start-Up section for correct compressor rotation. Compressor damage due to improper rotation is the responsibility of the installer.

Options

Economizer Start-Up	Page 38
Power Exhaust	Page 50
Barometric Relief Dampers	Page 51
Outdoor Air Dampers	Page 51
Outdoor Air Hoods	Page 51
Hot Gas Reheat	Page 53
Modulating Gas Valves	Page 55
Hot Gas Bypass	Page 56
Outdoor Air CFM Control	Page 57
Energy Recovery Wheels	Page 58

Service

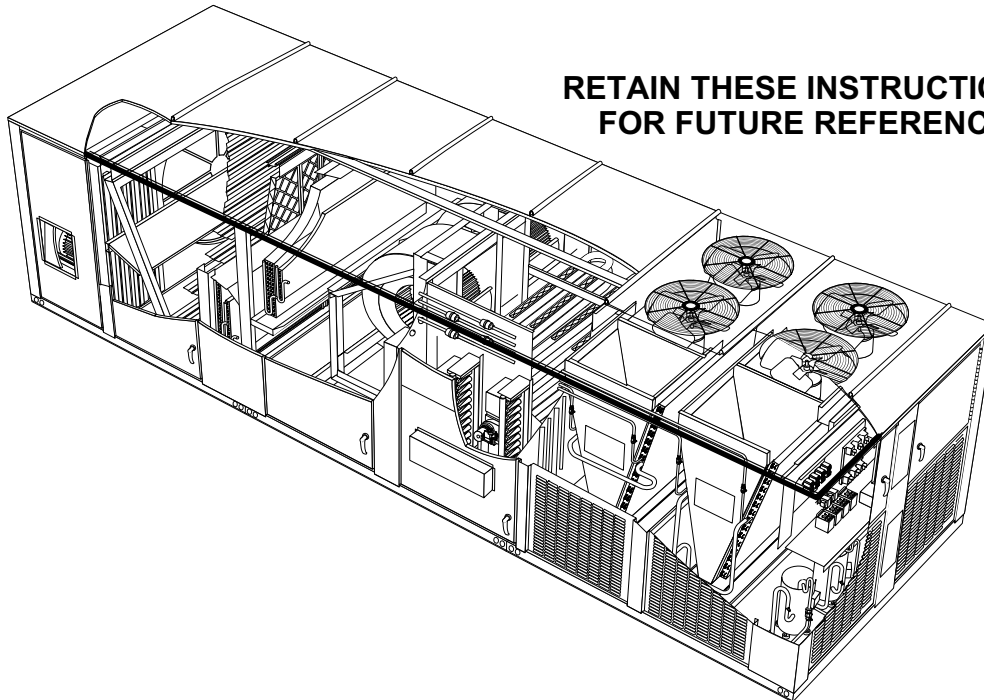

**RETAIN THESE INSTRUCTIONS
FOR FUTURE REFERENCE**

LGH/LCH 420, 480, 540, 600 Unit Dimensions Vertical Airflow - Inches (mm) - Gas Heat Shown

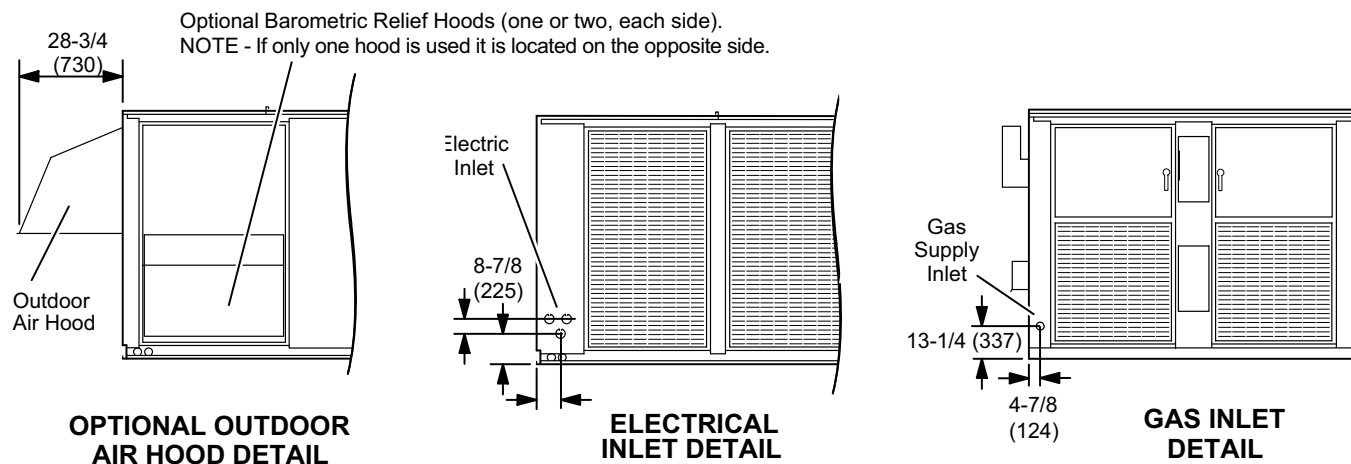
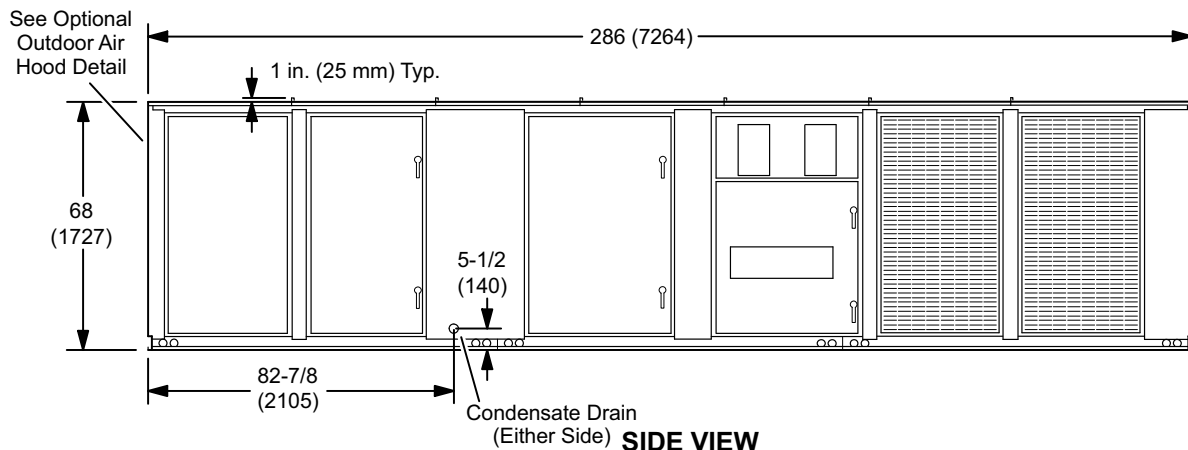
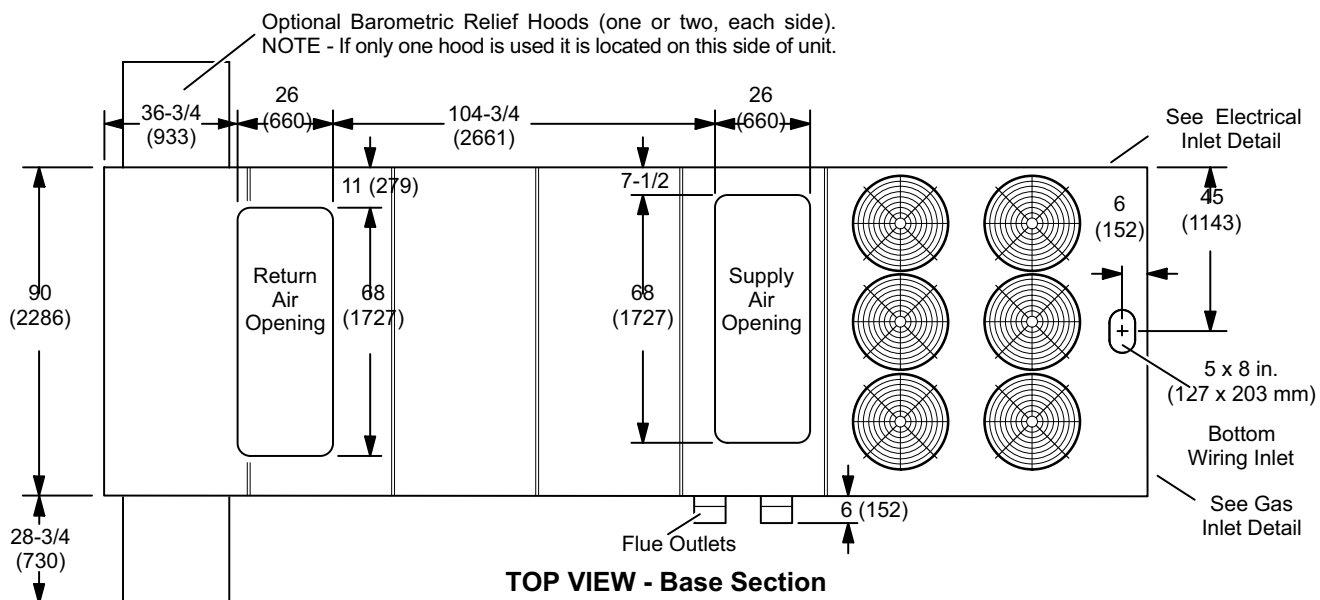

LGH/LCH420, 480, 540, 600 Unit Dimensions Horizontal Airflow - In. (mm) - Gas Heat Shown

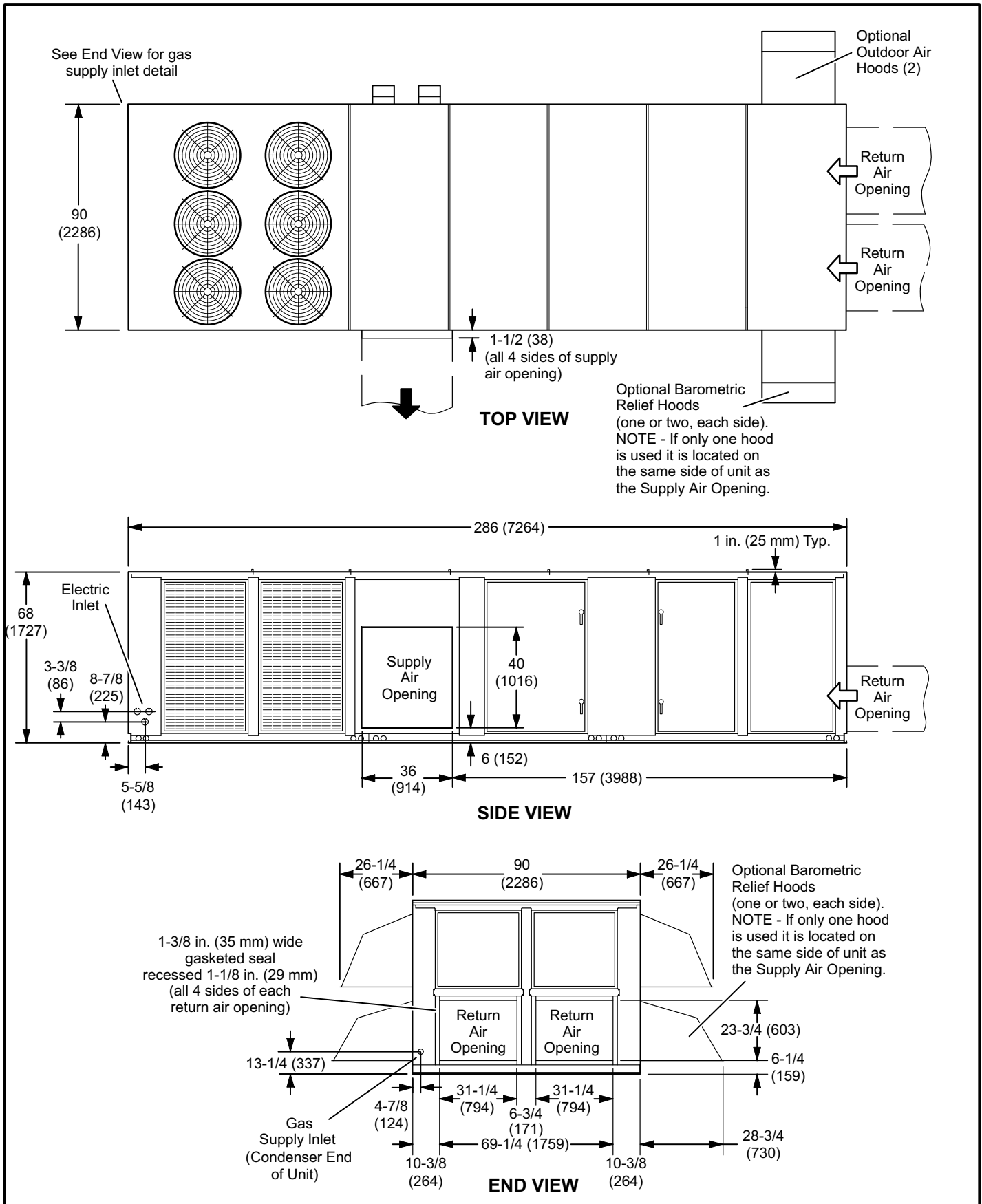

LGH420, 480, 540, 600 PARTS ARRANGEMENT

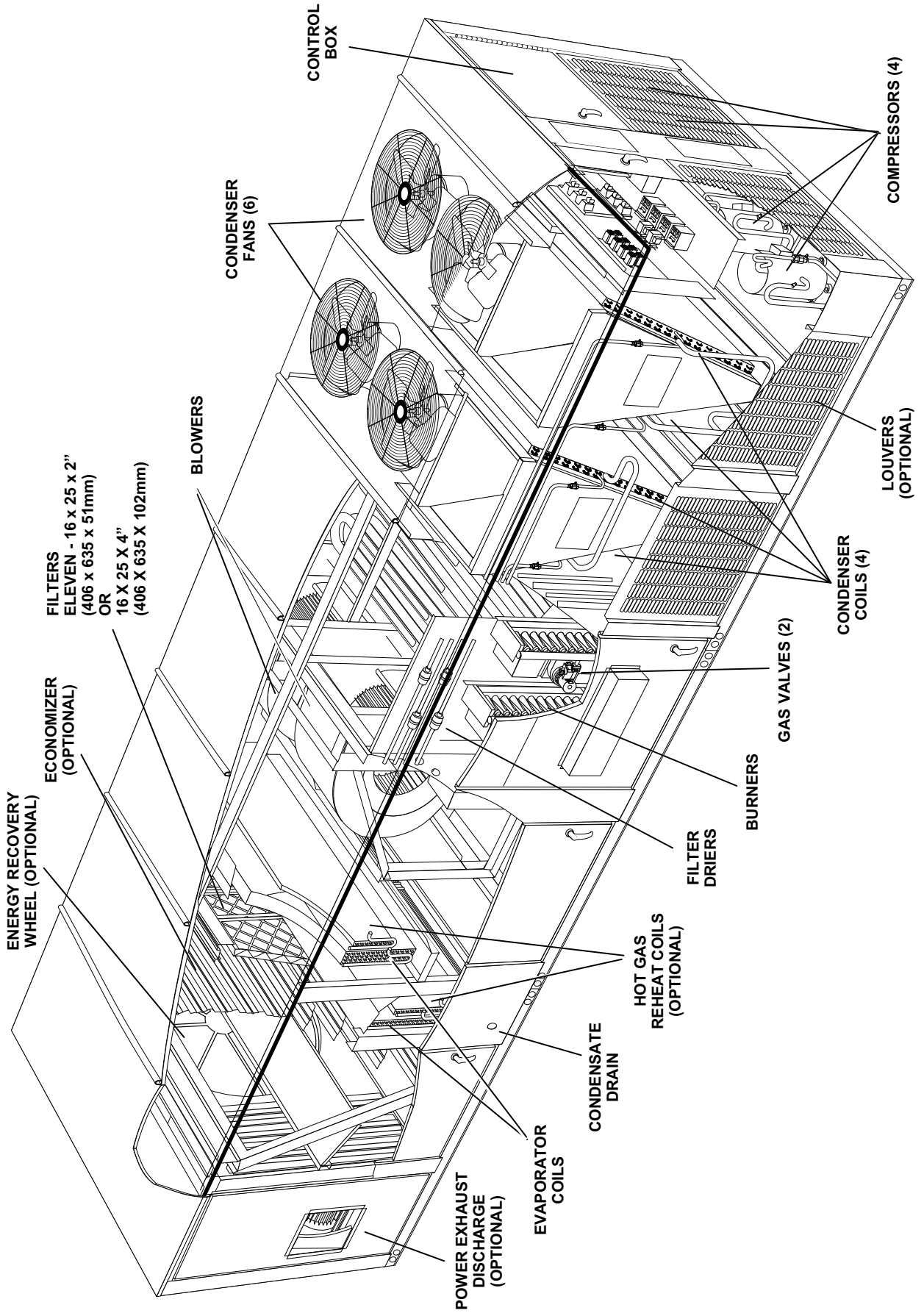

Shipping and Packing List

Package 1 of 1 contains:

- 1- Assembled unit

Check unit for shipping damage. Receiving party should contact last carrier immediately if shipping damage is found.

IMPORTANT - Hot gas reheat units require a specific field-provided and installed humidity sensor or digital input. Refer to control wiring section.

General

These instructions are intended as a general guide and do not supersede local codes in any way. Authorities having jurisdiction should be consulted before installation.

Use of this unit as a construction heater or air conditioner is not recommended during any phase of construction. Very low return air temperatures, harmful vapors and operation of the unit with clogged or misplaced filters will damage the unit.

If this unit has been used for heating or cooling of buildings or structures under construction, the following conditions must be met or the warranty will be void:

- The vent hood must be installed per these installation instructions.
- A room thermostat must control the unit. The use of fixed jumpers that will provide continuous heating or cooling is not allowed.
- A pre-filter must be installed at the entry to the return air duct.
- The return air duct must be provided and sealed to the unit.
- Return air temperature range between 55°F (13°C) and 80°F (27°C) must be maintained.
- Air filters must be replaced and pre-filters must be removed upon construction completion.
- The input rate and temperature rise must be set per the unit rating plate.
- The heat exchanger, components, duct system, air filters and evaporator coil must be thoroughly cleaned following final construction clean-up.
- The unit operating conditions (including airflow, cooling operation, ignition, input rate, temperature rise and venting) must be verified according to these installation instructions.

Requirements

See figure 1 for unit clearances.

⚠ WARNING



Electric shock hazard and danger of explosion. Can cause injury, death or product or property damage. Turn off gas and electrical power to unit before performing any maintenance or servicing operations on the unit. Follow lighting instructions attached to unit when putting unit back into operation and after service or maintenance.

⚠ IMPORTANT

The Clean Air Act of 1990 bans the intentional venting of refrigerant (CFC's and HCFC's) as of July 1, 1992. Approved methods of recovery, recycling or reclaiming must be followed. Fines and/or incarceration may be levied for non-compliance.

⚠ NOTICE

Roof Damage!

This system contains both refrigerant and oil. Some rubber roofing material may absorb oil, causing the rubber to swell. Bubbles in the rubber roofing material can cause leaks. Protect the roof surface to avoid exposure to refrigerant and oil during service and installation. Failure to follow this notice could result in damage to roof surface.

Unit Support

⚠ CAUTION

As with any mechanical equipment, contact with sharp sheet metal edges can result in personal injury. Take care while handling this equipment and wear gloves and protective clothing.

In downflow discharge installations, install the unit on a non-combustible surface only. Unit may be installed on combustible surfaces when used in downflow discharge applications when installed on an S1CURB10E-1 roof mounting frame.

NOTE - Securely fasten roof frame to roof per local codes.

⚠ CAUTION

To reduce the likelihood of supply / return air bypass and promote a proper seal with the RTU, duct work / duct drops / diffuser assemblies must be supported independently to the building structure.

A-Downflow Discharge Application

Roof Mounting with S1CURB10E-1

- 1- The S1CURB10E-1 roof mounting frame must be installed, flashed and sealed in accordance with the instructions provided with the frame.
- 2- The S1CURB10E-1 roof mounting frame should be square and level to 1/16" per linear foot (1.6mm per 305 linear mm) in any direction.
- 3- Duct must be attached to the roof mounting frame and not to the unit; supply and return plenums must be installed before setting the unit.

Installer's Roof Mounting Frame

Many types of roof frames can be used to install the unit depending upon different roof structures. Items to keep in mind when using the building frame or supports are:

- 1- The base is fully enclosed and insulated, so an enclosed frame is not required.
- 2- The frames or supports must be constructed with non-combustible materials and should be square and level to 1/16" per linear foot (1.6mm per 305 linear mm) in any direction.
- 3- Frame or supports must be high enough to prevent any form of moisture from entering unit. Recommended minimum frame height is 14" (356mm).
- 4- Duct must be attached to the roof mounting frame and not to the unit. Supply and return plenums must be installed before setting the unit.

- 5- Units require support along all four sides of unit base. Supports must be constructed of steel or suitably treated wood materials.

Duct Connection

All exterior ducts, joints and openings in roof or building walls must be insulated and weather-proofed with flashing and sealing compounds in accordance with applicable codes. Any duct passing through an unconditioned space must be insulated.

⚠ CAUTION

In downflow applications, do not drill or punch holes in base of unit. Leaking in roof may occur if unit base is punctured.

Horizontal Supply Air

- 1- Locate horizontal discharge air flanges in blower section.
- 2- Remove and discard horizontal supply air shipping cover from supply air panel on back side of unit. See figure 2.
- 3- Position flanges as shown in figure 2. Make sure the narrow side of the flange is positioned on the inside of the unit panel. Secure with screws from the inside of the unit.
- 4- Secure ductwork to flanges per applicable codes.

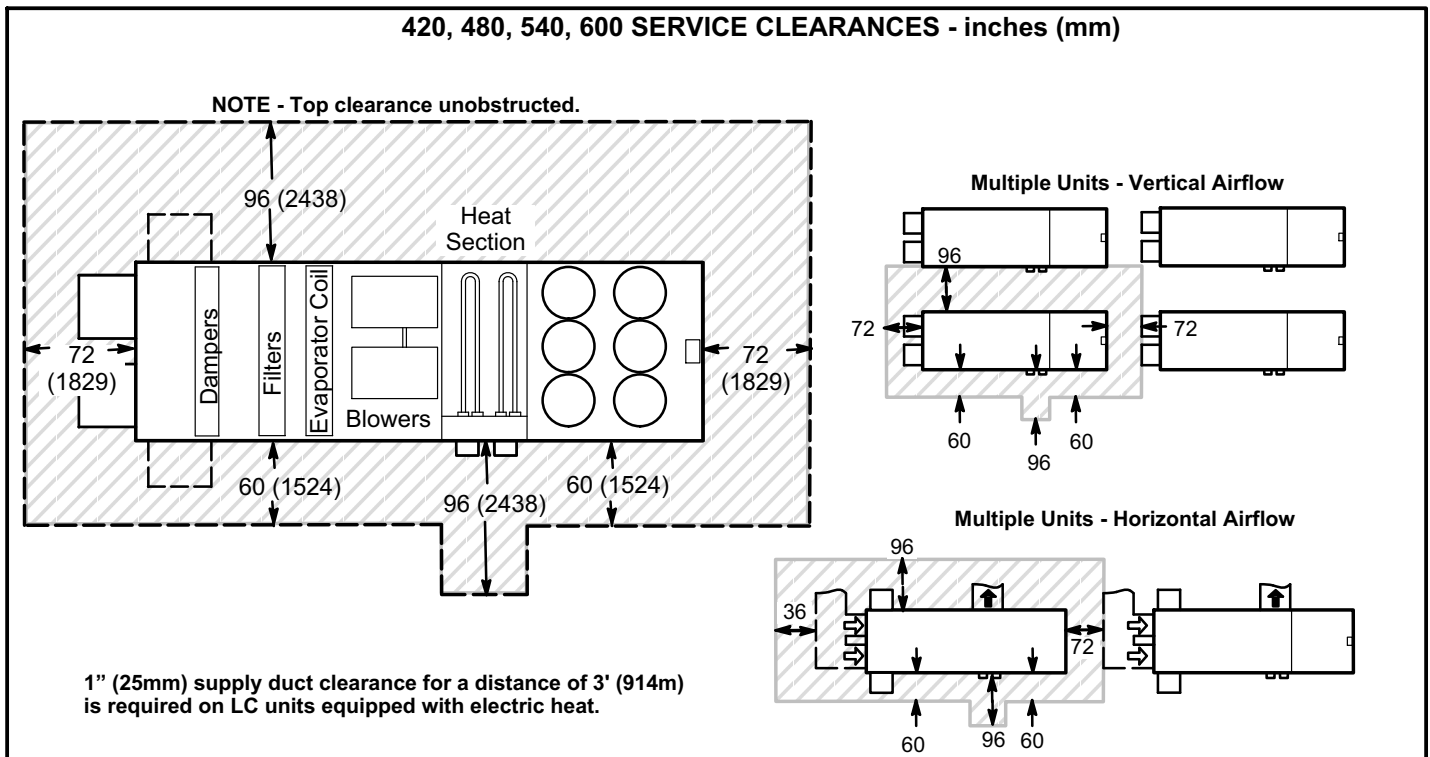

FIGURE 1

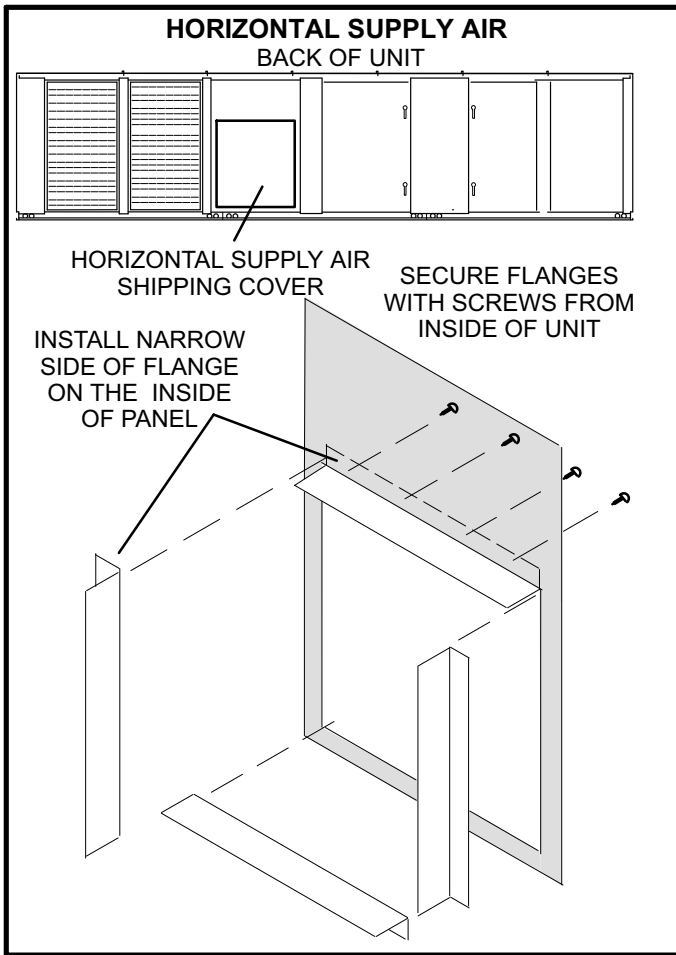

FIGURE 2

Rigging Unit For Lifting

- 1- Connect rigging to the unit base rail using holes in each corner and unit sides. **ALL 8 POINTS MUST BE USED FOR HOISTING.** See figure 3.
- 2- All panels must be secured in place before lifting.
- 3- Three field-provided spreader bars must be used. THE LENGTHWISE SPREADER BAR MUST BE AT LEAST 16 FEET (5 METERS) LONG. The horizontal spreader bars must be at least 90 inches (2.3m) long to prevent unit damage.

Unit	Maximum Weight*	
	Lbs.	Kgs.
420	8545	3875
480	8575	3889
540	8585	3893
600	8600	3900

*Maximum weight with all available factory-installed accessories.

Shipping Blocks

Note - Wooden shipping blocks are installed only in units equipped with optional factory-installed spring mounts.

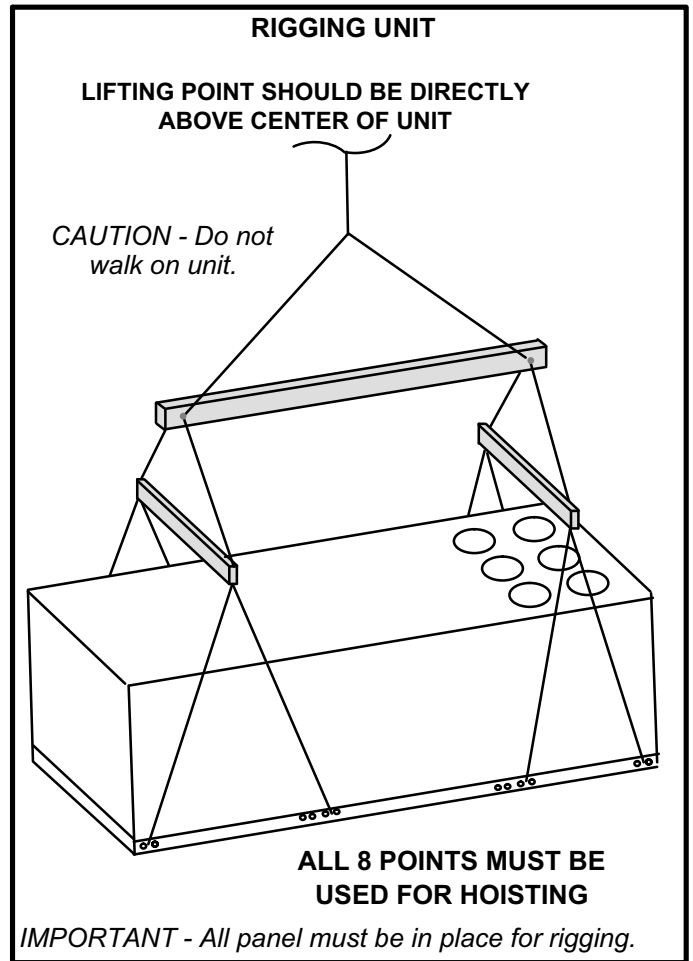

FIGURE 3

Compressor Hat Section Shipping Blocks

- 1- Remove screws and open front and back hinged condenser access panels. See figure 4 for panel location.
- 2- Remove two shipping blocks beneath the compressor hat section. Access one shipping block from the front side of the unit as shown in figure 5. The other shipping block is located in the same place on the back side of the unit.
- 3- Remove shipping screws. See figure 5.

Indoor Blower Shipping Blocks

- 1- Open front and back blower access panels. See figure 4 for panel location.
- 2- Remove four shipping blocks and screws located beneath the indoor blower frame. Access two shipping blocks from the back side of the unit as shown in figure 6. Access the other two shipping blocks from the same place on the front side of the unit.

Power Exhaust Shipping Blocks

1- Open access panels on return end end of unit. See figure 4.

2- Remove four shipping blocks and screws beneath the power exhaust assembly frame as shown in figure 7.

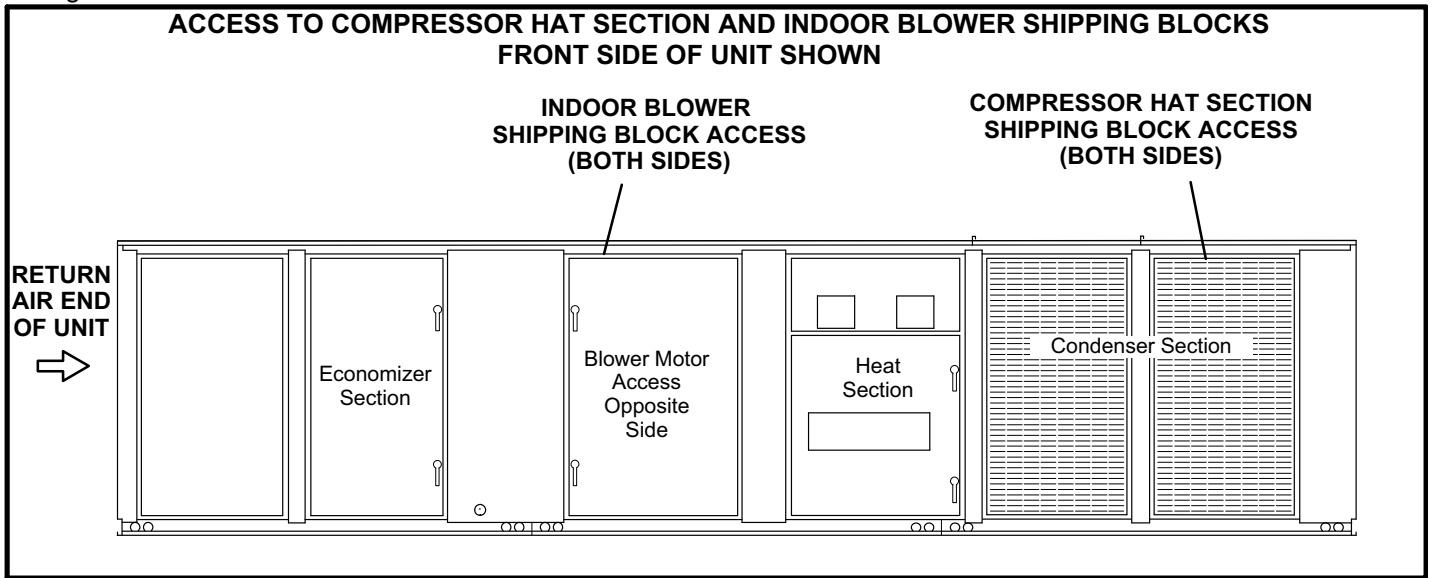

FIGURE 4

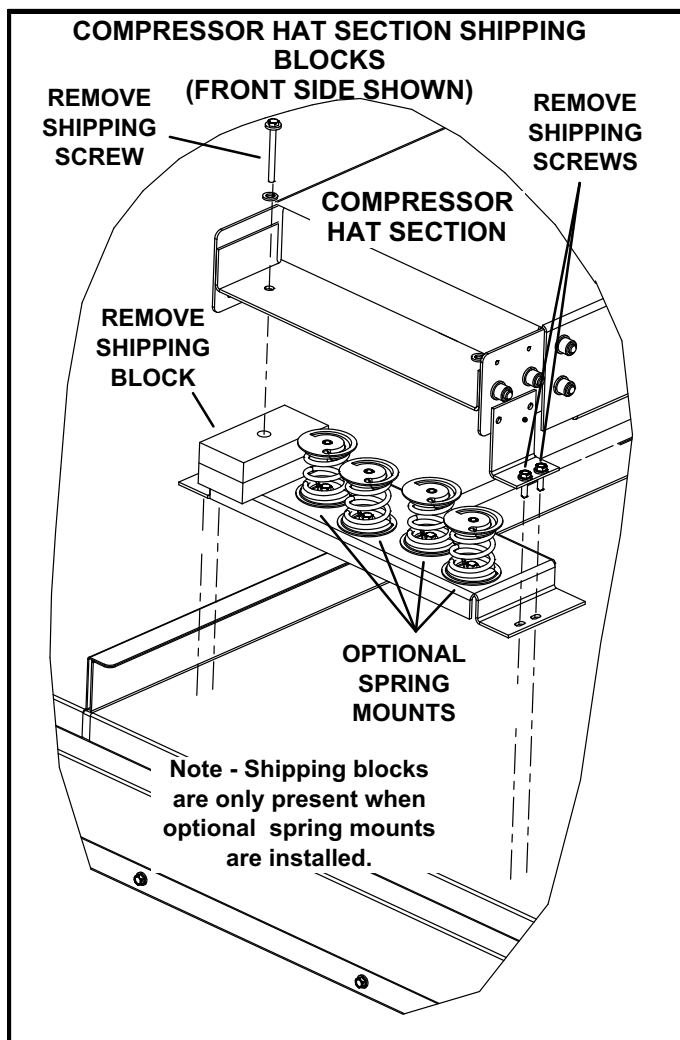

FIGURE 5

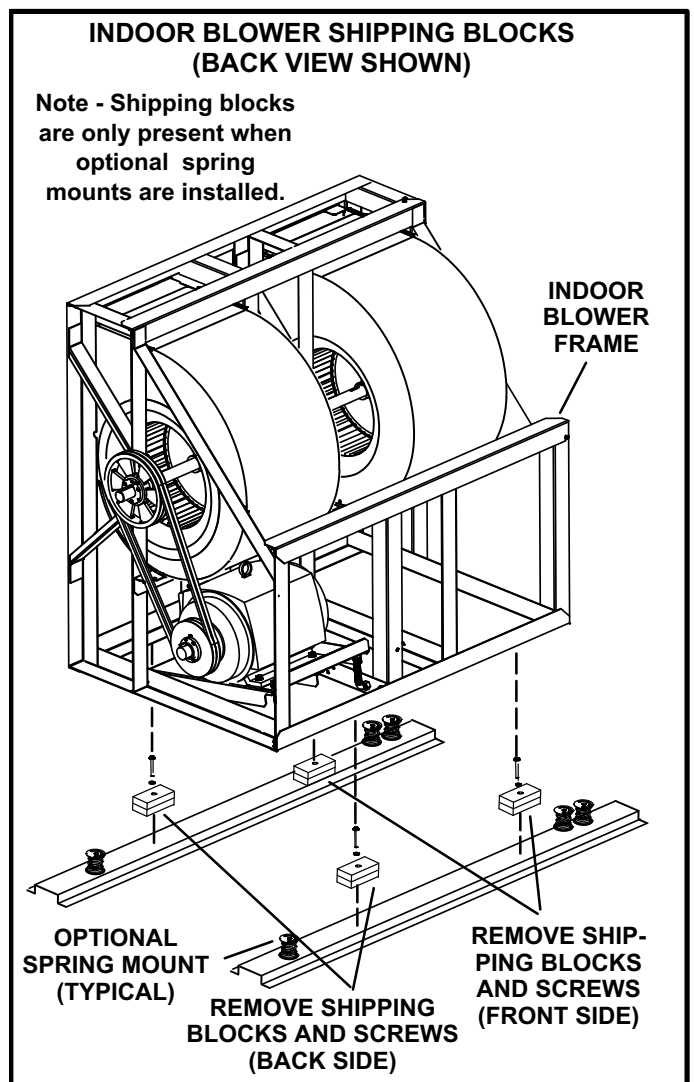
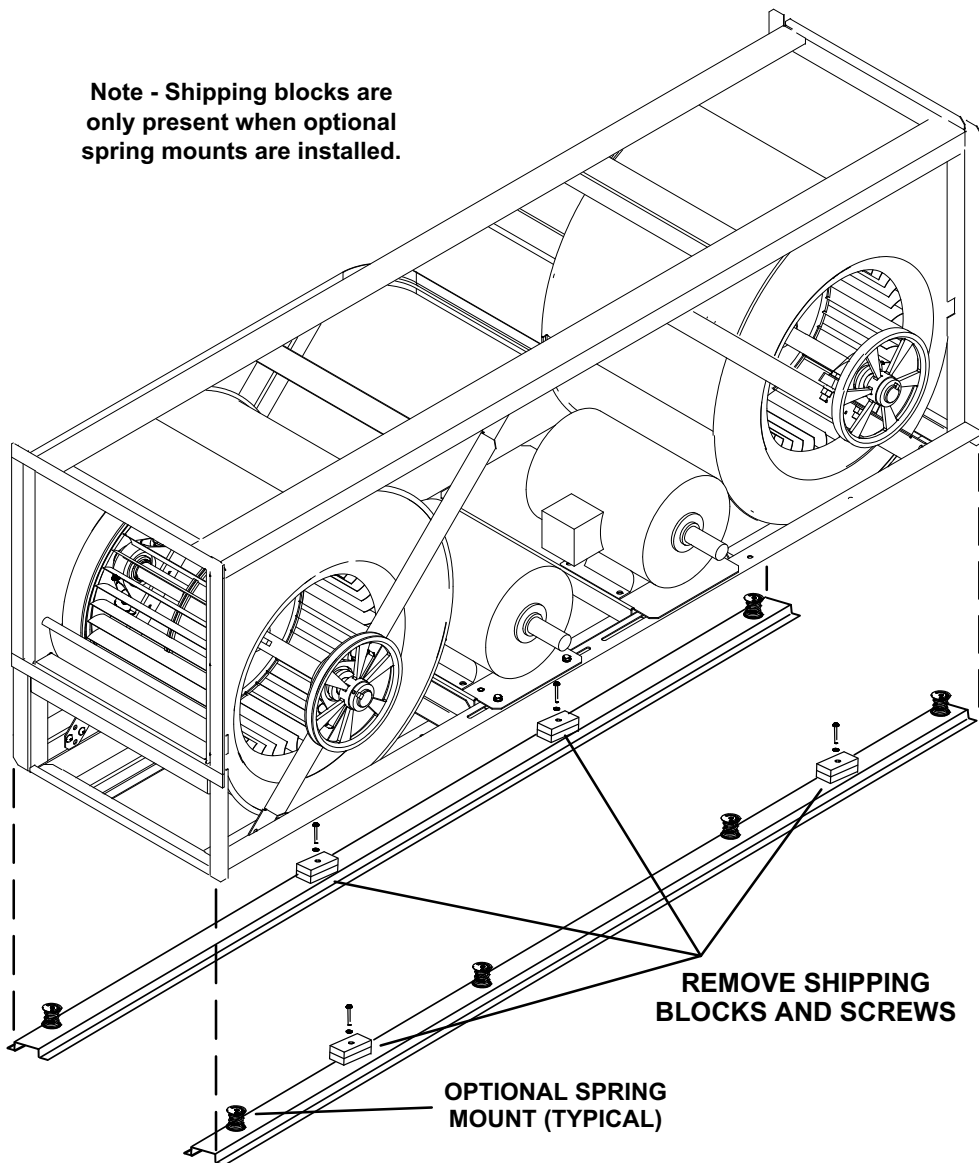

FIGURE 6

POWER EXHAUST SHIPPING BLOCKS

Note - Shipping blocks are only present when optional spring mounts are installed.



REMOVE SHIPPING
BLOCKS AND SCREWS

OPTIONAL SPRING
MOUNT (TYPICAL)

FIGURE 7

Reverse Condensate Drain Pan

Unit is shipped from the factory with the condensate drain facing the front of the unit. Reverse drain pan when needed as follows:

1- Remove blower door on front of unit. See figure 8 and 9.

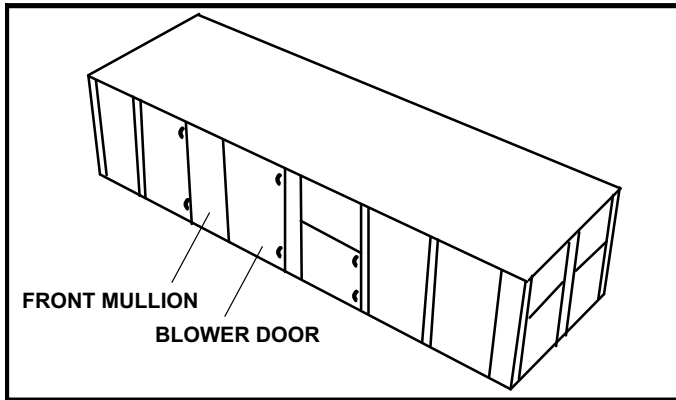

FIGURE 8

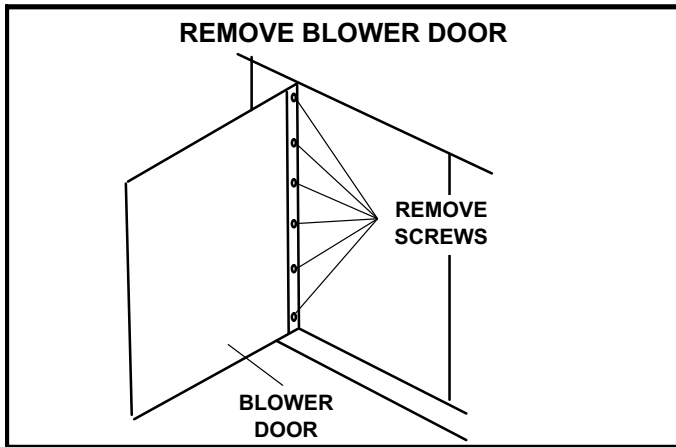

FIGURE 9

- 2- Remove and retain the patch plate on the front mullion.
- 3- Remove front mullion.
- 4- Remove and retain three screws securing drip shield. See figure 10.
- 5- Locate the patch plate on the back mullion. Remove the patch plate and install on the front mullion.
- 6- Remove back mullion.
- 7- Install patch plate from the front mullion on the back mullion. Position the patch plate in the same location as the previous patch plate.

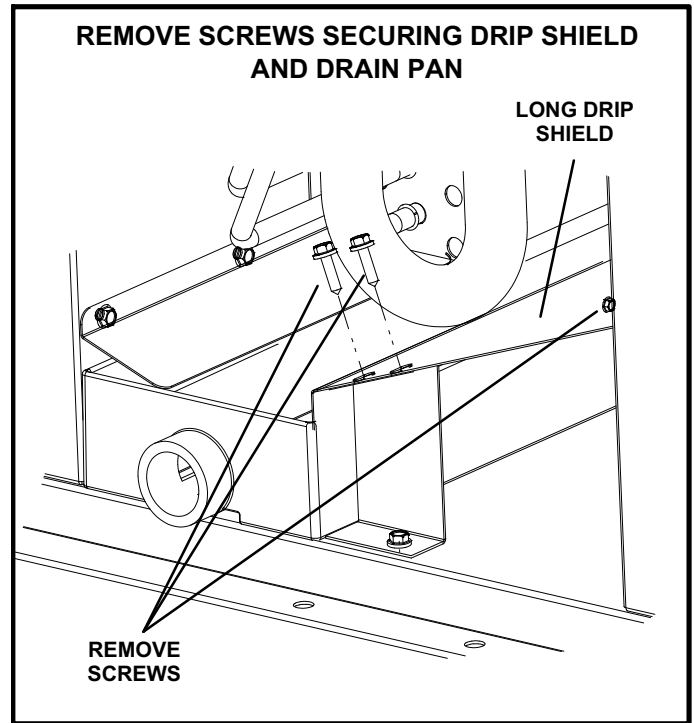

FIGURE 10

- 8- Remove and retain three screws securing drip shields on back side of unit. See figure 11. Remove long drip shield.
- 9- Push the drain pan downward and remove from unit.
- 10- Rotate the drain pan and reinstall.
- 11- Reinstall long drip shield with retained screws.
- 12- Replace mullions and blower door.

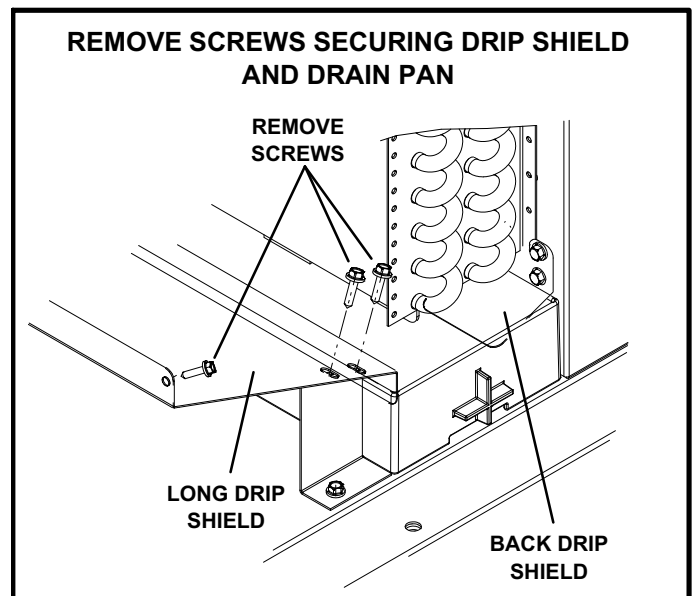

FIGURE 11

Condensate Drain

Make drain connection to the 1" N.P.T. drain coupling provided on unit. A trap must be installed between drain connection and an open vent for proper condensate removal. See figure 12. It is sometimes acceptable to drain condensate onto the roof or grade; however, a tee should be fitted to the trap to direct condensate downward. The condensate line must be vented. Check local codes concerning condensate disposal. Refer to pages 1 and 2 for condensate drain location.

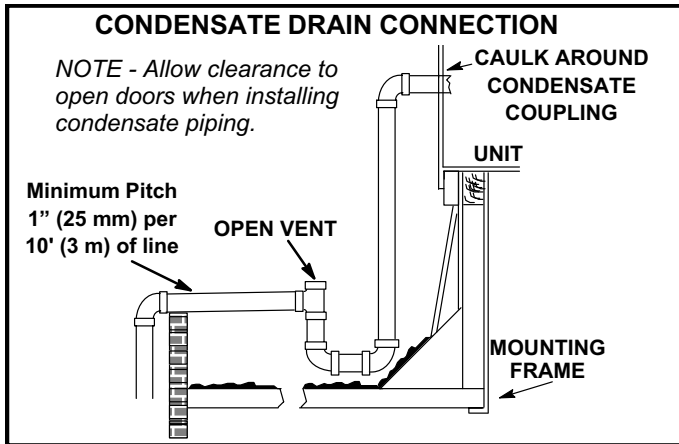

FIGURE 12

Connect Gas Piping

Two grommets are packaged with the flue exhaust and air intake hoods located in the gas heat section. Grommets are installed in the unit entry and gas heat division panel knockouts. An additional grommet is required when routing gas piping through the bottom of the unit.

Before connecting piping, check with gas company or authorities having jurisdiction for local code requirements. When installing gas supply piping, length of run from gas meter must be considered in determining pipe size for 0.5" w.c. (.12kPa) maximum pressure drop. Do not use supply pipe smaller than unit gas connection. For natural gas units, operating pressure at the unit gas connection must be a minimum of 6.0" w.c. (1.5kPa) and a maximum of 14" (3.50kPa) w.c. For LP/propane gas units, operating pressure at the unit gas connection must be a minimum of 11" w.c. (2.74kPa) and a maximum of 13.5" w.c. (3.36kPa).

When making piping connections a drip leg should be installed on vertical pipe runs to serve as a trap for sediment or condensate. A 1/8" N.P.T. plugged tap is located on gas valve for test gauge connection. Refer to Heating Start-Up section for tap location. Install a ground joint union between the gas control manifold and the main manual shut-off valve. See figure 13 for side entry gas supply piping.

Compounds used on threaded joints of gas piping shall be resistant to the action of liquified petroleum gases.

Pressure Test Gas Piping

When pressure testing gas lines, the gas valve must be disconnected and isolated. Gas valves can be damaged if subjected to more than 0.5 psig (3.5kPa). See figure 14.

NOTE-Codes may require that manual main shut-off valve and union (furnished by installer) be installed in gas line external to unit. Union must be of the ground joint type.

After all connections have been made, check all piping connections for gas leaks. Also check existing gas connections up to the gas valve; loosening may occur during installation. Use a leak detection solution or other preferred means. Do not use matches candles or other sources of ignition to check for gas leaks.

NOTE-In case emergency shut down is required, turn off the main manual shut-off valve and disconnect main power to unit. These devices should be properly labeled by the installer.

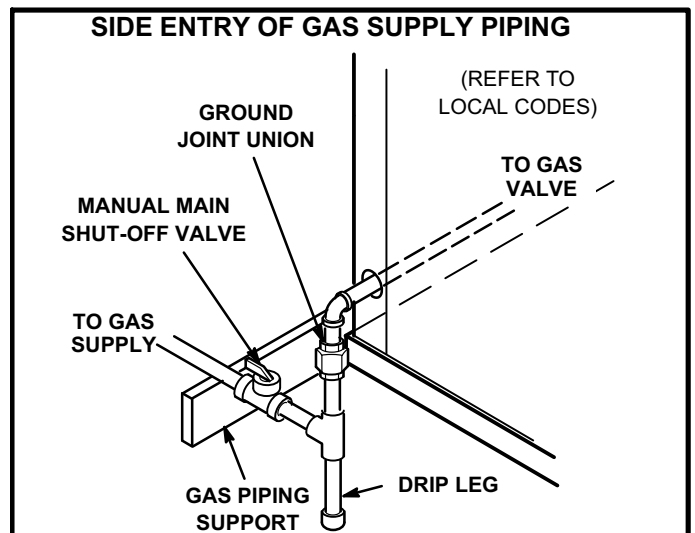

FIGURE 13

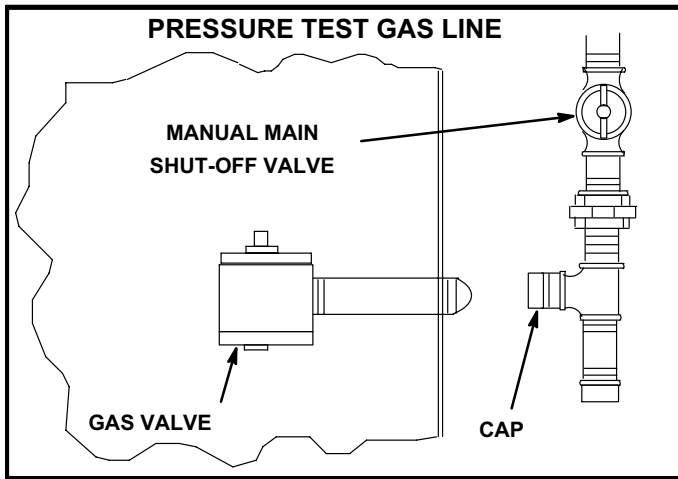

FIGURE 14

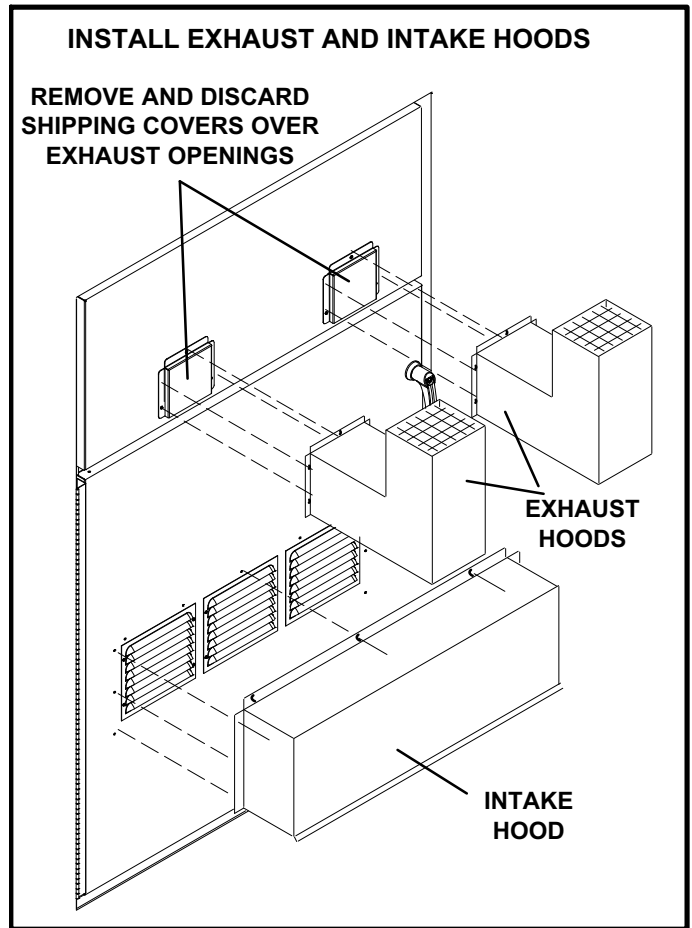

FIGURE 15

⚠ CAUTION
 Some soaps used for leak detection are corrosive to certain metals. Carefully rinse piping thoroughly after leak test has been completed. Do not use matches, candles, flame or other sources of ignition to check for gas leaks.

⚠ WARNING
 Danger of explosion. Can cause injury or product or property damage. Do not use matches, candles, flame or other sources of ignition to check for leaks.

Flue and Intake Hoods

Hoods are shipped in the gas heat section. Install as shown in figure 15. Secure with screws provided.

Two grommets are also shipped with the hood assemblies for gas piping knockouts. Install one grommet in the gas piping entry knockout. Install the other grommet in the heat section division panel knockout.

High Altitude Derate

Locate the high altitude conversion sticker in the unit literature bag. Fill out the conversion sticker and affix next to the unit nameplate.

Refer to table 1 for high altitude adjustments.

**TABLE 1
 HIGH ALTITUDE DERATE**

Altitude Ft.*	Gas Manifold Pressure
2000-4500	See Unit Nameplate
4500 And Above	Derate 4% / 1000 Ft. Above Sea Level

*Units installed at 0-2000 feet do not need to be modified.

NOTE - This is the only permissible derate for these units.

Electrical Connections

POWER SUPPLY

Do not apply power or close disconnect switch until installation is complete. Refer to start-up directions in Cooling Start-Up section. Refer closely to unit wiring diagram.

Refer to unit nameplate for minimum circuit ampacity and maximum fuse size.

1-T1 Control Transformer -

Units are factory-wired for 240/460/575 volt supply. For 208V supply, remove the insulated terminal cover from the 208V terminal on the control transformer. Move the wire from the transformer 240V terminal to the 208V terminal. Place the insulated terminal cover on the unused 240V terminal.

2- T18 Contactor Transformer -

230/460/575 volt units are factory wired. For 208V supply, disconnect the orange wire (230V) at control power transformer(s). Reconnect the red wire (208V). Tape the exposed end of the 230V orange wire.

- 3- Route electrical supply through the bottom or rear electric entry area and connect to line side of TB2. See unit dimensions in the front of this manual. If unit has optional disconnect or circuit breaker, connect power wiring to disconnect or circuit breaker. See unit wiring diagram.

If unit is equipped with optional electric heat and dual power supply is specified, refer to electric heat wiring diagram on inside unit panels. See figure 16.

- 3- *Units With Optional Field-Wired 120v GFCI Outlet -*
Route and connect separate 120v wiring to GFCI outlets which do not have factory-installed wiring.

CONTROL WIRING

A-Thermostat Location

Locate thermostat approximately 5 feet (1524mm) above the floor in an area with good air circulation at average temperature. Avoid locating the room thermostat where it might be affected by:

- drafts or dead spots behind doors and in corners
- hot or cold air from ducts
- radiant heat from sun or appliances
- concealed pipes and chimneys

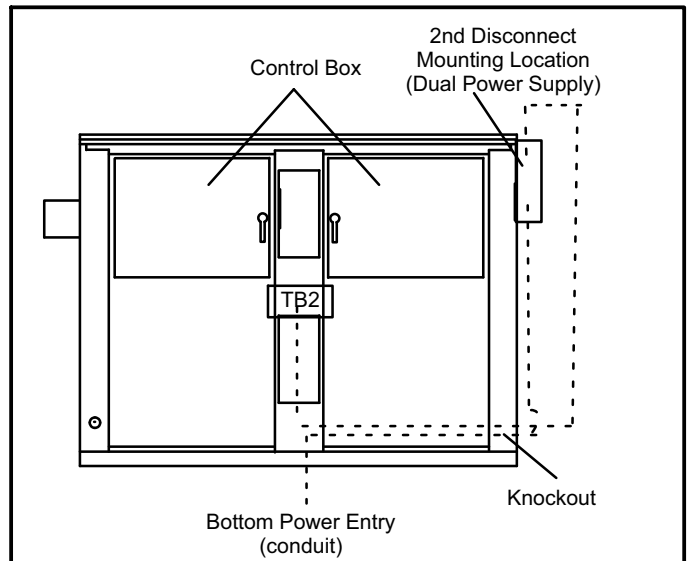

FIGURE 16

B-Wire Routing

Route thermostat cable or wires from subbase through knockout or bottom power entry area provided in unit. Use 18 AWG wire for all applications using remotely installed electro-mechanical and electronic thermostats.

IMPORTANT - Unless field thermostat wires are rated for maximum unit voltage, they must be routed away from line voltage wiring.

On hot gas reheat units, route wires from RH sensor or remote switch through knockout or bottom power entry area. For sensor installations, use 22AWG stranded, two twisted pairs, individually shielded, 100% aluminum shield with drain wire and Teflon jacket.

C-Wiring Connections

This unit is equipped with a Unit Controller which controls unit function. Refer to the Unit Controller manual provided with each unit.

The Unit Controller will operate the unit from a thermostat, zone sensor, or zoning system based on the System Mode. The default System Mode is the thermostat mode. Refer to the Unit Controller Installation and Setup Guide to change the System Mode. Use the menu navigation arrows and select button; see **SETTINGS>CONTROL**.

1- **Default Thermostat Mode -**

The Unit Controller will operate two stages of heating and cooling based on thermostat demands. Install thermostat assembly in accordance with instructions provided with thermostat. See figure 17 and wiring diagrams on unit for field wiring.

IMPORTANT-Terminal connections at the wall plate or subbase must be made securely. Loose control wire connections may result in intermittent operation.

24 VOLT FIELD WIRING IN THERMOSTAT MODE
 (Unit Controller in default T'Stat System Mode 6.01 Option 0)

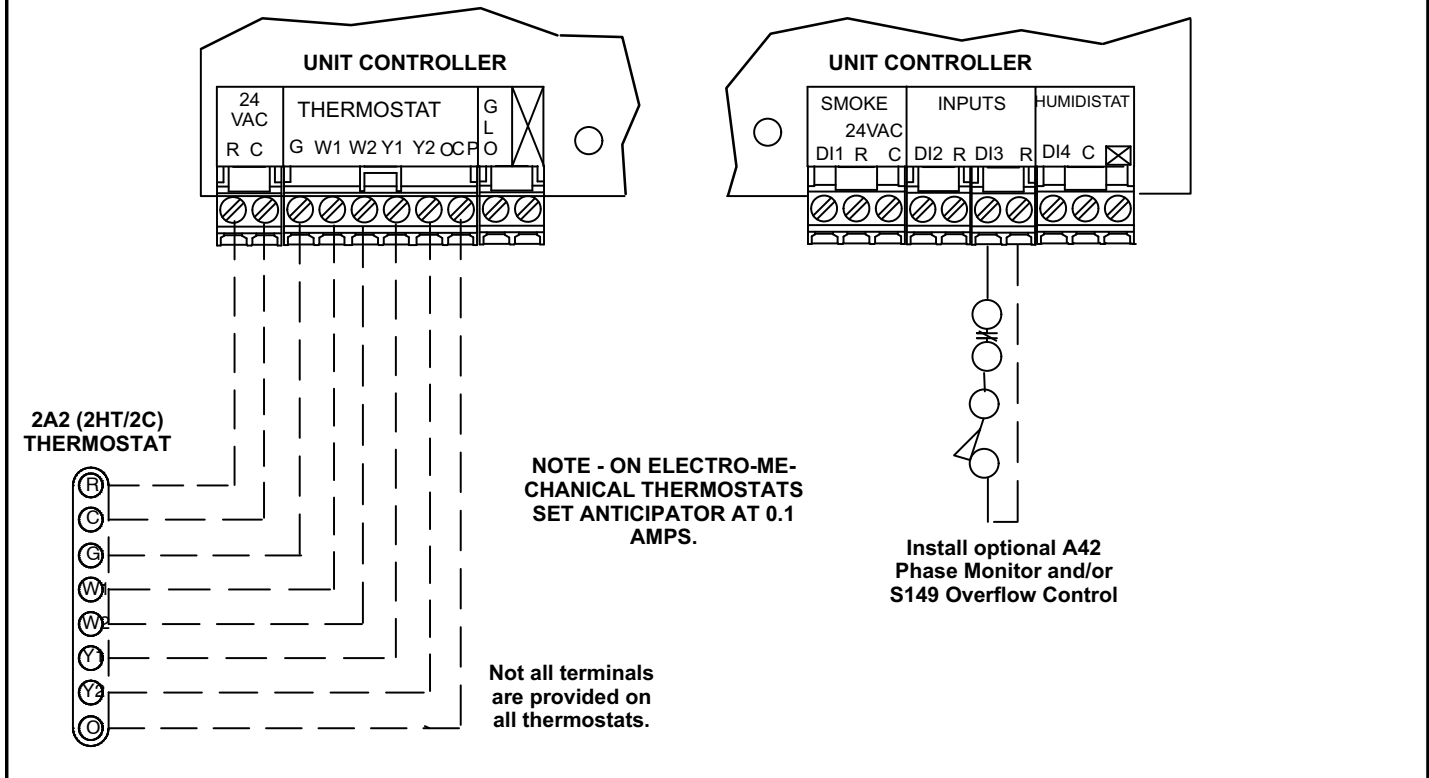

FIGURE 17

2- Zone Sensor Mode -

The Unit Controller will operate up to four stages of heating and cooling based on the Unit Controller internal setpoints and the temperature from the A2 zone sensor. An optional Network Control Panel (NCP)

can also be used to provide setpoints. A thermostat or return air sensor can be used as a back-up mode. See figure 18 for field wiring.

Note - Install sensor and make communication wiring connections as shown in literature provided with sensor.

24 VOLT FIELD WIRING IN ZONE SENSOR MODE
 (Unit Controller in Zone Sensor Mode)

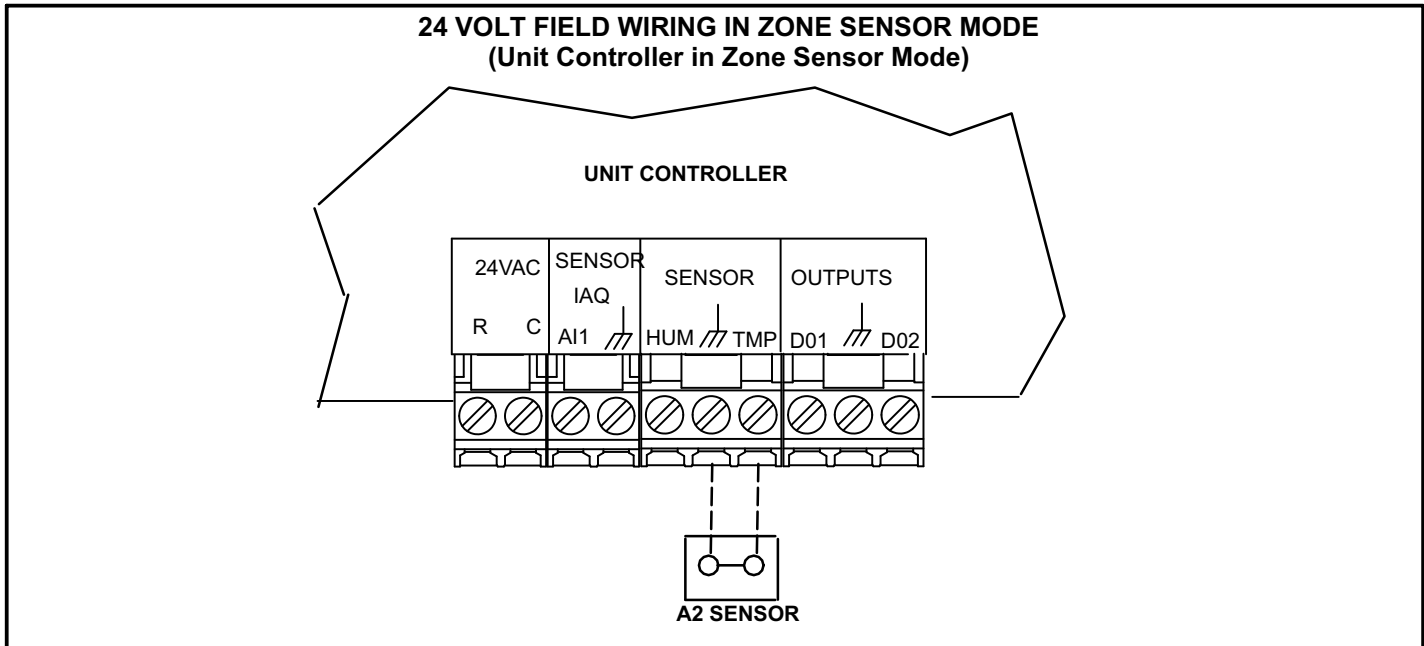

FIGURE 18

3- Third-Party Zoning -

The Unit Controller will operate up to four stages of heating and cooling based on a third-party zoning system. Only 4 digital inputs are required to control the rooftop unit: G (blower enable), OCP (occupied), Y1 (enables discharge cooling) and W1 (enables discharge heating). Make wiring connections as shown in figure 19.

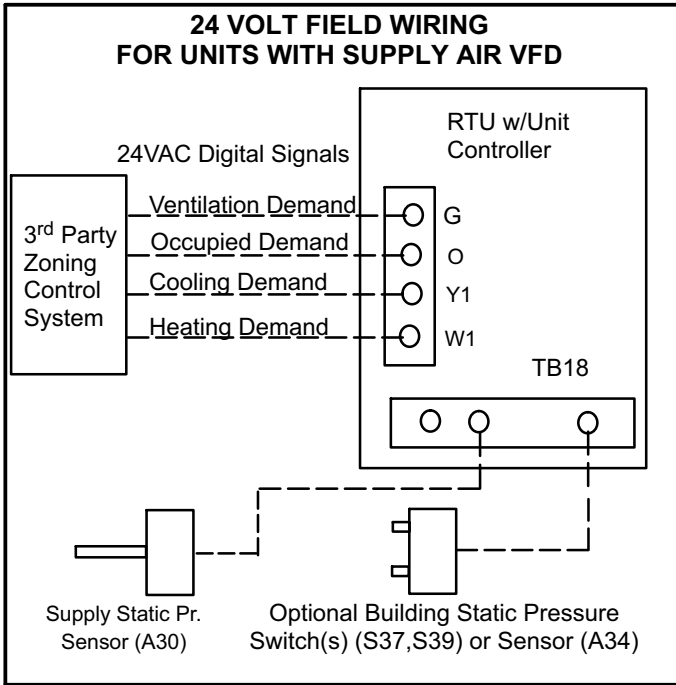

FIGURE 19

D-Hot Gas Reheat Units Only -

Install humidity sensor in accordance with instructions provided with sensor. A DDC input may be used to initiate dehumidification instead of a sensor. Make wiring connections as shown in figure 17 for Thermostat Mode and figure 18 for Zone Sensor Mode. In addition, connect either a zone sensor or a dehumidification input as shown in figure 20.

Humidity Sensor Cable Applications:

Wire runs of 50 feet (mm) or less:

Use two separate shielded cables containing 20AWG minimum, twisted pair conductors with overall shield. Belden type 8762 or 88760 (plenum) or equivalent. Connect both cable shield drain wires to TB1-7 as shown in figure 20.

Wire runs of 150 feet (mm) or less:

Use two separate shielded cables containing 18AWG minimum, twisted pair conductors with overall shield. Belden type 8760 or 88760 (plenum) or equivalent. Connect both cable shield drain wires to TB1-7 as shown in figure 20.

Wire runs over 150 feet (mm):

Use a local, isolated 24VAC transformer such as Lennox cat #18M13 (20VA minimum) to supply power to RH sensor as shown in figure 21. Use two shielded cables containing 20AWG minimum, twisted pair conductors with overall shield. Belden type 8762 or 88760 (plenum) or equivalent.

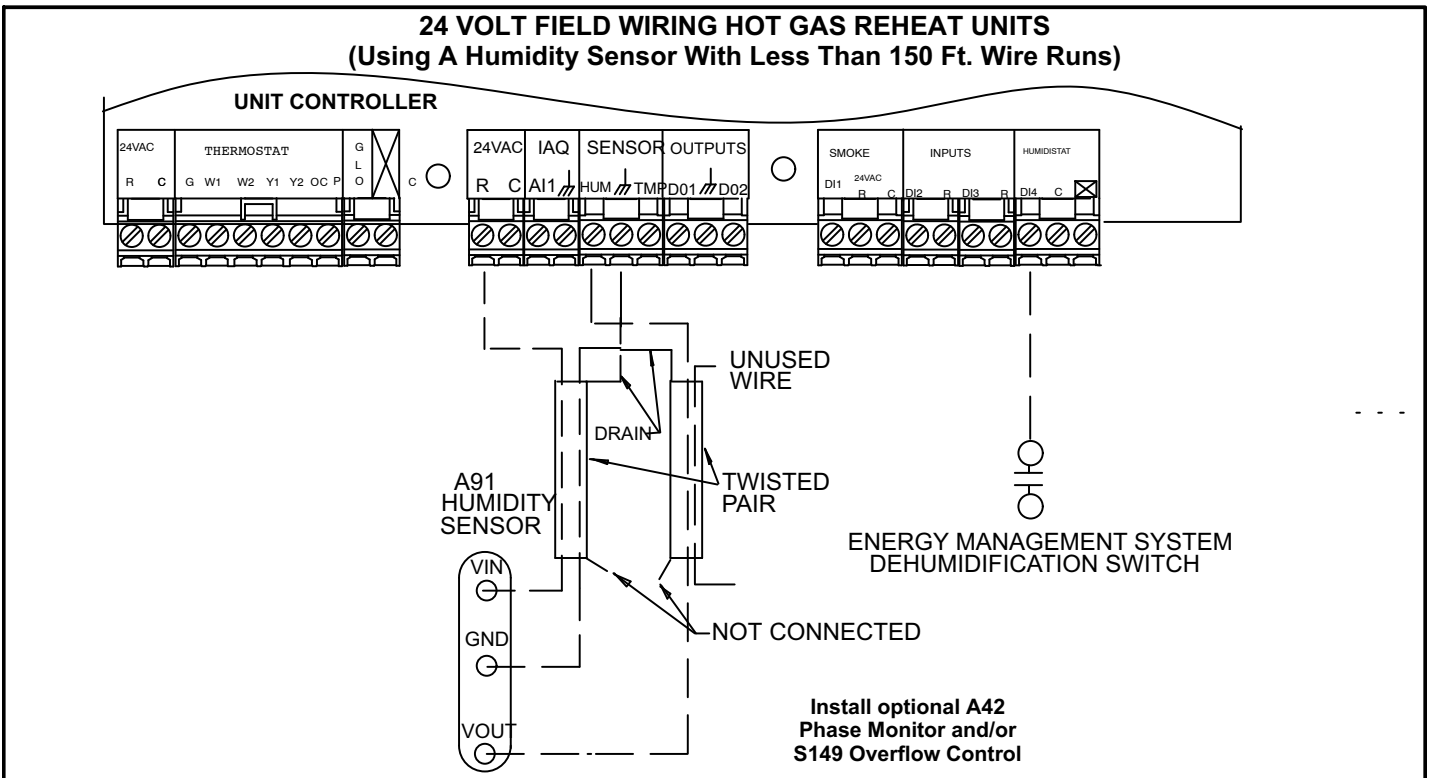

FIGURE 20

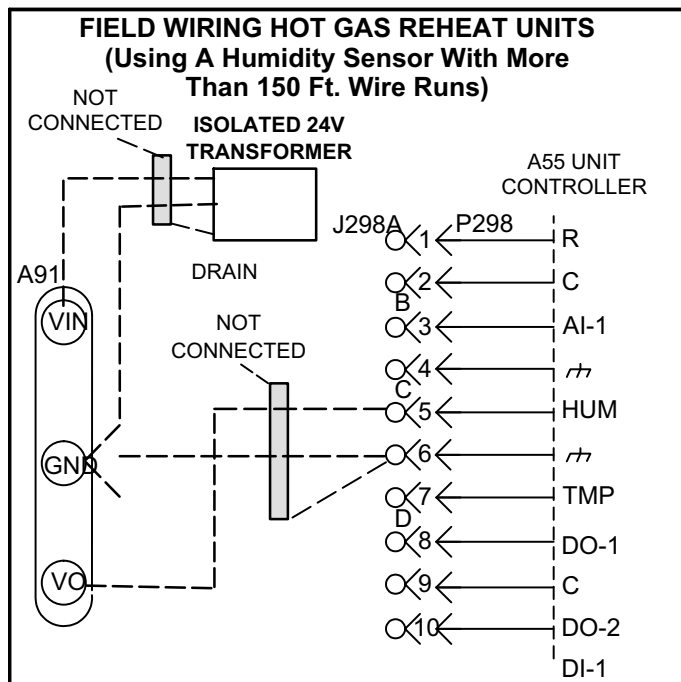

FIGURE 21

TABLE 2
Blower CFM Design Specifications

No. Stages / Control Type	Blower Speed ¹	Design Specified CFM
2 Stages / Thermostat	Htg.	
	Clg. High	
	Clg. Low	
3 Stages / Thermostat ²	Htg.	
	Clg. High	
	Clg. Med.	
	Clg. Low	
	Ventilation	
4 Stages / Room Sensor OR Discharge Air Control	Htg.	
	Clg. High	
	Clg. Med. High	
	Clg. Med. Low	
	Ventilation	

Multi-Staged Air Volume Start-Up

A-Design Specifications

Use table 2 to fill in field-provided, design specified blower CFM for appropriate unit.

If only high and low cooling design specifications are provided, set the medium cooling CFM at the high or low cooling design spec or any CFM between.

B-Set Maximum CFM

Use table 2 to determine highest blower CFM for appropriate unit. Adjust the blower pulley to deliver that amount of CFM with only the blower operating. See *Determining Unit CFM* in the Blower Operation and Adjustment section.

C-Set Blower Speeds

1-Use the following menu to enter the blower design specified CFM into the Unit Controller. Make sure blower CFM is within limitations shown in table 3. Refer to the Unit Controller manual provided with unit.

SETUP > TEST & BALANCE > BLOWER >

2-Enter the following design specifications as shown in table 2.

- Blower / Heat CFM
- Cooling High CFM¹
- Cooling Low CFM¹
- Vent CFM

¹Available blower speeds vary by unit and thermostat stages.

²Requires a transfer relay (K27) and three-stage thermostat.

3-Adjust the blower RPM to deliver the target CFM based on the measured static pressure using the blower table.

4-Measure the static pressure again and apply the static pressure and RPM to the blower tables to determine adjusted CFM.

5-Repeat adjustments until design CFM is reached.

¹The Unit Controller will prompt when more cooling stages are available depending on the number of compressors and the control mode.

²Requires a transfer relay (K27) and three-stage thermostat.

D-Set Damper Minimum Position

To maintain required minimum ventilation air volumes when the unit is in the occupied mode, two minimum damper positions must be set. The Unit Controller will open the dampers to “Min OCP Blwr Low” when blower CFM is BELOW a “midpoint” CFM. The Unit Controller will open the damper to “Min OCP Blwr High” when blower CFM is at or ABOVE the “midpoint” CFM.

The Unit Controller will calculate the “midpoint” CFM.

Set Minimum Position 1

Use the following menu in the Unit Controller to set “Min OCP Blwr Low” for the blower CFM below the “midpoint” CFM. When navigating into this menu, the Unit Controller will bring on the corresponding blower speed and allow damper position adjustment.

**SETTINGS > RTU OPTIONS > EDIT PARAMETER >
ENTER DATA ID - 9 > MIN DAMPER LOW BLOWER =
X.X%**

Measure the intake air CFM. If the CFM is lower than the design specified CFM for ventilation air, use the Unit Controller to increase the damper percent open. If the CFM is higher than specified, decrease the damper percent open.

Note - Intake air CFM can also be determined using the outdoor air temperature, return air temperature and mixed air temperature. Refer to the economizer or outdoor air damper installation instructions.

Set Minimum Position 2

Use the same menu in the Unit Controller to set “Min OCP Blwr High” for the blower CFM above the “midpoint” CFM. When navigating into this menu, the Unit Controller will bring on the corresponding blower speed and allow damper position adjustment.

**SETTINGS > RTU OPTIONS > DAMPER > MIN
DAMPER POSITION BLOWR ON HIGH = X.X%**

Measure the intake air CFM. If the CFM is lower than the design specified CFM for ventilation air, use the Unit Controller to increase the damper percent open. If the CFM is higher than specified, decrease the damper percent open.

Note - Intake air CFM can also be determined using the outdoor air temperature, return air temperature and mixed air temperature. Refer to the economizer or outdoor air damper installation instructions.

E-Inverter Bypass Option

The supply air inverter is factory-set to by-pass the inverter manually. To by-pass the inverter and operate the blower in the constant air volume mode, use the following Unit Controller menu and set to “engaged”:

**SETTINGS > RTU OPTIONS > BLOWER > VFD
BYPASS**

To configure the unit to by-pass the inverter automatically, use the following Unit Controller menu.

SETUP > INSTALL

Press SAVE until the menu reads:

CONFIGURATION ID 1

Change the 6th character position to A for automatic bypass option.

Press SAVE

Caution - Units not equipped with an inverter will have the 6th character set to N, indicating the inverter is not bypassed. The blower motor could be damaged and/or result in product or property damage if the setting is changed to automatic or manual.

**TABLE 3
MINIMUM AND MAXIMUM CFM - STAGED BLOWERS**

Gas Heat Minimum CFM		
Unit	Gas Heat Size	Airflow CFM
LGH420-600	Std, Std Mod	9300
LGH420-600	High, High Mod	10800
Electric Heat Minimum CFM		
Unit	Heat Size (kw)	Airflow CFM
LCH420	All	9800
LCH480	All	11200
LCH540	All	12600
LCH600	All	14000
Cooling minimum CFM		
Unit	Blower Speed	Airflow CFM
LGH/LCH420	Cool 1; Clg. Low	5600
	Cool 2; Clg. Med. Low	5600
	Cool 3; Clg. Med. High	5600
	Cool 4; Clg. High	9800
LGH/LCH480	Cool 1; Clg. Low	6400
	Cool 2; Clg. Med. Low	6400
	Cool 3; Clg. Med. High	6400
	Cool 4; Clg. High	11200
LGH/LCH540	Cool 1; Clg. Low	7200
	Cool 2; Clg. Med. Low	7200
	Cool 3; Clg. Med. High	7200
	Cool 4; Clg. High	12600
LGH/LCH600	Cool 1; Clg. Low	8000
	Cool 2; Clg. Med. Low	8000
	Cool 3; Clg. Med. High	8000
	Cool 4; Clg. High	14000
Smoke and Ventilation Minimum CFM		
Unit	Not Applicable	Airflow CFM
LGH/LCH420	NA	5250
LGH/LCH480	NA	6000
LGH/LCH540	NA	6750
LGH/LCH600	NA	7500
Heating and Cooling Maximum CFM		
Unit	Blower Speed	Airflow CFM
LGH/LCH420	High	16800
LGH/LCH480	High	19200
LGH/LCH540	High	21600
LGH/LCH600	High	24000

Variable Air Volume Start-Up

Units may contain an optional supply air blower equipped with a variable frequency drive A96 (VFD) which varies supply air CFM.

The supply air VFD (A96) is located near the compressors. See figure 22.

A-Start-Up

- 1- A pressure transducer (A30) is shipped in a box in the blower compartment. Install the transducer according to manufacturer's instructions.

Note - Make sure the transducer is installed in the main duct at least 2/3 of the distance away from the unit.

- 2- Two twisted pairs of shielded cable must be used to connect the pressure transducer. See figure 23.
- 3- Open all zone dampers and/or boxes.
- 4- Locate the A55 Unit Controller in the control box.
- 5- Use the Unit Controller to calibrate the blower CFM. Select the **SETUP->TEST & BALANCE->BLOWER** menu to start the blower. The Unit Controller will display the percent of blower speed. Adjust blower speed percentage to meet design airflow specifications. Allow blower speed to stabilize.
- 6- Press SAVE to display the current static pressure. If the static pressure meets the design specification, press SAVE again to set the setpoint. If the static pressure does not meet the design specification, adjust the pressure and press SAVE to set the setpoint.

- 7- Record new setpoints in table 4.

Note - The Unit Controller will lock-out the unit for 5 minutes if static pressure exceeds 2.0" w.c. for 20 seconds. The Unit Controller will permanently shut down the unit after three occurrences. See Unit Controller parameters 110, 42, and 43 to adjust default values.

- 8- If the desired CFM cannot be met with current pulley setup, refer to the *Blower Operation and Adjustments* section to adjust CFM.

B-Unit Operation

Use the Unit Controller to check unit mechanical operation. See the *Service - Test* section of the Unit Controller manual.

C-Supply Air VFD By-Pass Plug (Optional)

IMPORTANT - All dampers must be open to prevent damage to duct work and dampers.

**TABLE 4
RECORD ADJUSTED SETPOINTS**

Parameter	Setpoint Description	Setpoint "w.c.	Display Setting
386	Smoke		
387	Ventilation		
388	Heating		
389	Cooling		

The supply air VFD may be by-passed using jack/plug connections. Locate J/P198 connectors in control box area under the relays. Disconnect J198 from P198 and connect J204 to P198. See figure 24. Blower will operate in constant air volume mode.

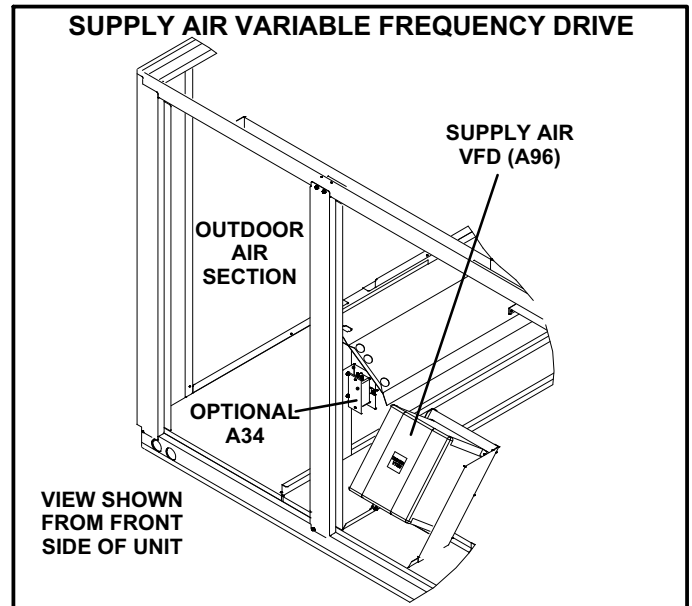

FIGURE 22

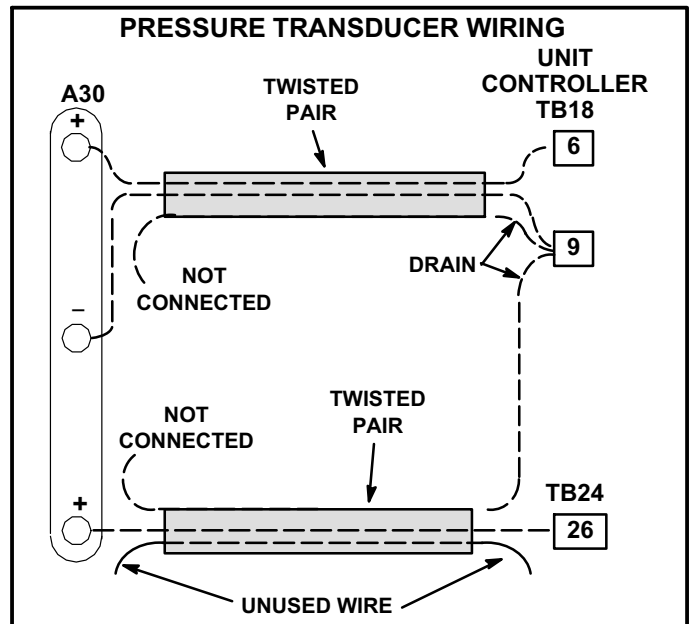

FIGURE 23

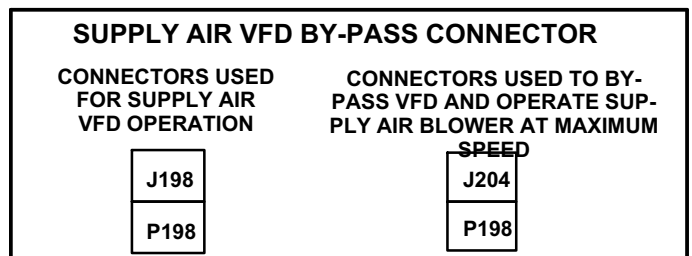

FIGURE 24

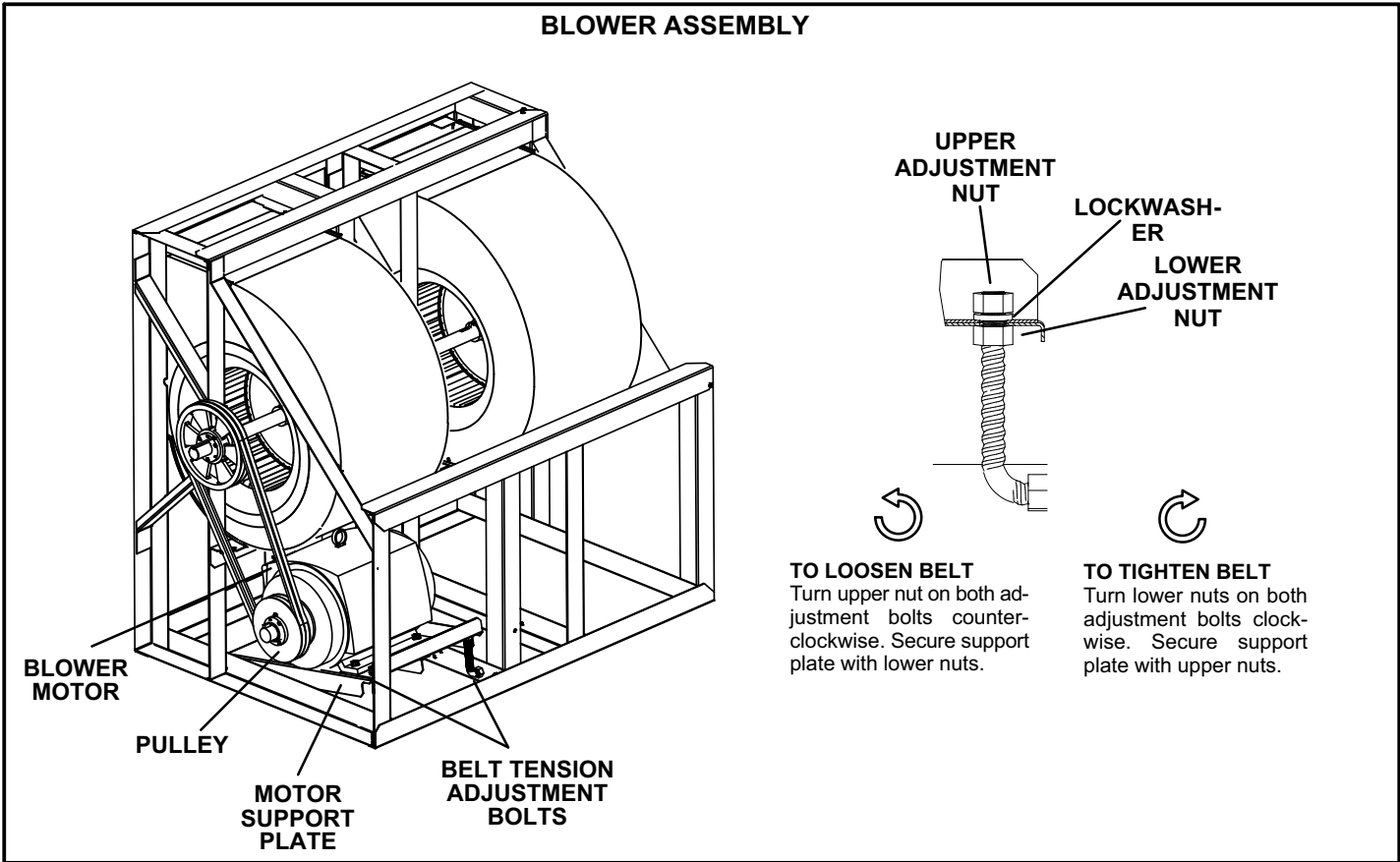

FIGURE 25

Blower Operation and Adjustments

⚠ IMPORTANT

Three phase scroll compressors must be phased sequentially for correct compressor and blower rotation. Follow "COOLING START-UP" section of installation instructions to ensure proper compressor and blower operation.

A-Blower Belt Adjustment

Maximum life and wear can be obtained from belts only if proper pulley alignment and belt tension are maintained. Tighten belt as shown in figure 25.

⚠ IMPORTANT

After a 24-48 hour period of operation, tighten new belts again. This will allow belt to stretch and seat into grooves.

Make sure blower and motor pulley are aligned as shown in figure 26. Also make sure motor support plate is level. See figure 27.

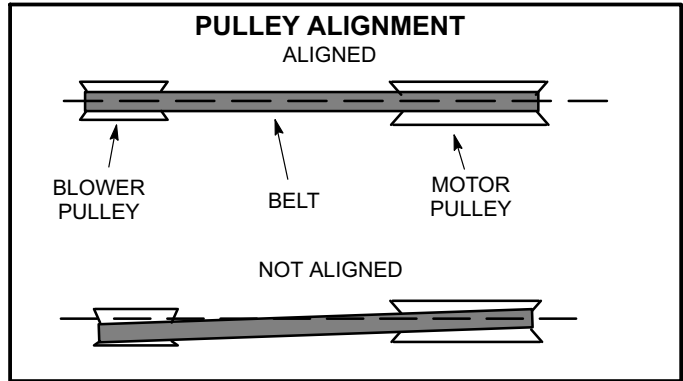

FIGURE 26

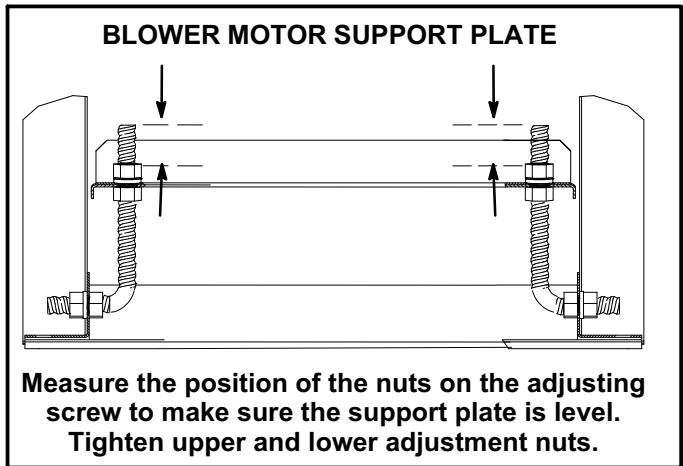

FIGURE 27

B-Check Belt Tension

Overtensioning belts shortens belt and bearing life. Check belt tension as follows:

1-Measure span length X. See figure 28.

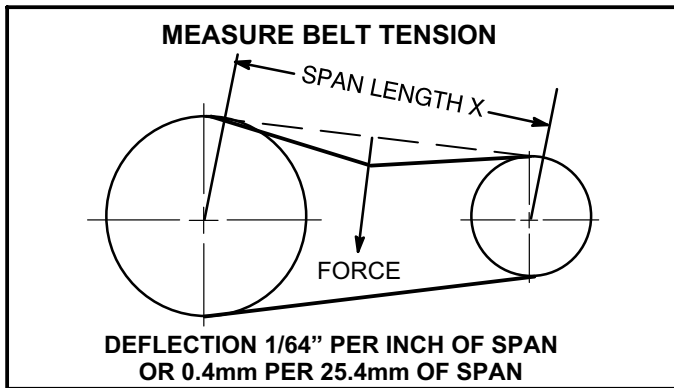

FIGURE 28

2-Apply perpendicular force to center of span (X) with enough pressure to deflect belt 1/64" for every inch of span length or 0.4mm per 25.4mm of span length.

Example: Deflection distance of a 40" span would be 40/64" or 5/8".

Example: Deflection distance of a 1016mm span would be 16mm.

3-Measure belt deflection force. Used belt values apply when tightening the belt after 24-48 hours.

For a used belt, the deflection force should be:

- 5 lbs. for 5 & 7.5 HP applications
- 8 lbs. for 10 & 15 HP applications
- 7 lbs. for 20, 25, & 30 HP applications

For a new belt, the deflection force should be:

- 8 lbs. for 5 & 7.5 HP applications

12 lbs. for 10 & 15 HP applications

11 lbs. for 20, 25, & 30 HP applications

A force below these values indicates an undertensioned belt. A force above these values indicates an overtensioned belt.

C-Blower Operation

Initiate blower only (G) demand at thermostat according to instructions provided with thermostat. Unit will cycle on thermostat demand. The following steps apply to applications using a typical electro-mechanical thermostat.

- 1- Blower operation is manually set at the thermostat subbase fan switch. With fan switch in **ON** position, blowers will operate continuously.
- 2- With fan switch in **AUTO** position, the blowers will cycle with demand. Blowers and entire unit will be off when system switch is in **OFF** position.

C-Determining Unit CFM

- 1- The following measurements must be made with a dry indoor coil. Run blower (G demand) without a cooling demand. Measure the indoor blower shaft RPM. Air filters must be in place when measurements are taken.
- 2- With all access panels in place, measure static pressure external to unit (from supply to return). Blower performance data is based on static pressure readings taken in locations shown in figure 29.
- 3- With all access panels in place, measure static pressure external to unit (from supply to return). Blower performance data is based on static pressure readings taken in locations shown in figure 29.

Note - Static pressure readings can vary if not taken where shown.

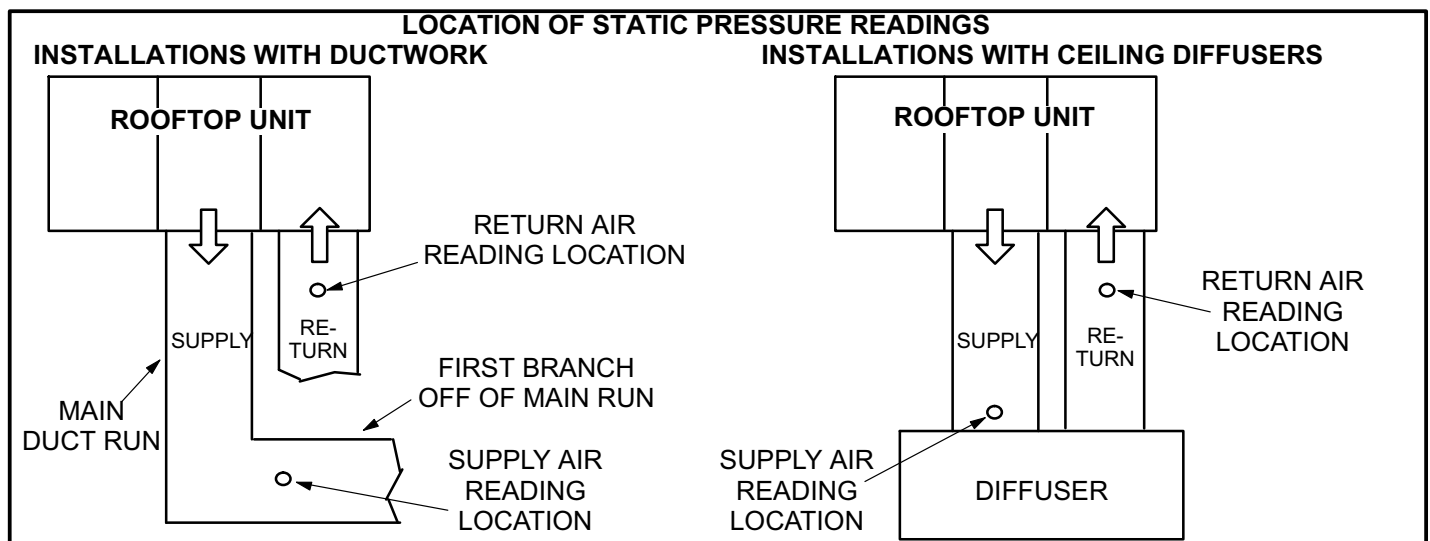

FIGURE 29

- 4- Referring to Page 22 and Page 23, use static pressure and RPM readings to determine unit CFM. Use Page 28 when installing the unit in horizontal air discharge applications. Use Page 29 when installing units with any of the optional accessories listed.
- 5- The blower RPM can be adjusted at the motor pulley. Loosen Allen screw and turn adjustable pulley clockwise to increase CFM. Turn counterclockwise to decrease CFM. See figure 30 and 25.

Loosen both Allen screws on units equipped with two belts. Remove the key and turn the inner sheave the opposite direction of the outer sheave. Replace the key before securing Allen screws.

6-Variable Air Volume Supply Air Blowers -

In addition to adjusting the motor pulley, the supply CFM can be adjusted at the Unit Controller or by using optional software. The VFD must be set to 60Hz. Refer to the Unit Controller manual parameter 390.

In default mode, the Unit Controller is set to drive the blower to maximum CFM output (100% or 60Hz). To decrease the CFM, reduce the VAV maximum output parameter 390. If the CFM needs to be increased beyond the motor pulley's capacity at 60Hz, refer to the drive kit options in this manual to see if there may be a different drive kit available to increase CFM.

The default minimum blower output is 50% (30Hz). Refer to parameter 27 and 28 to adjust the VAV minimum output.

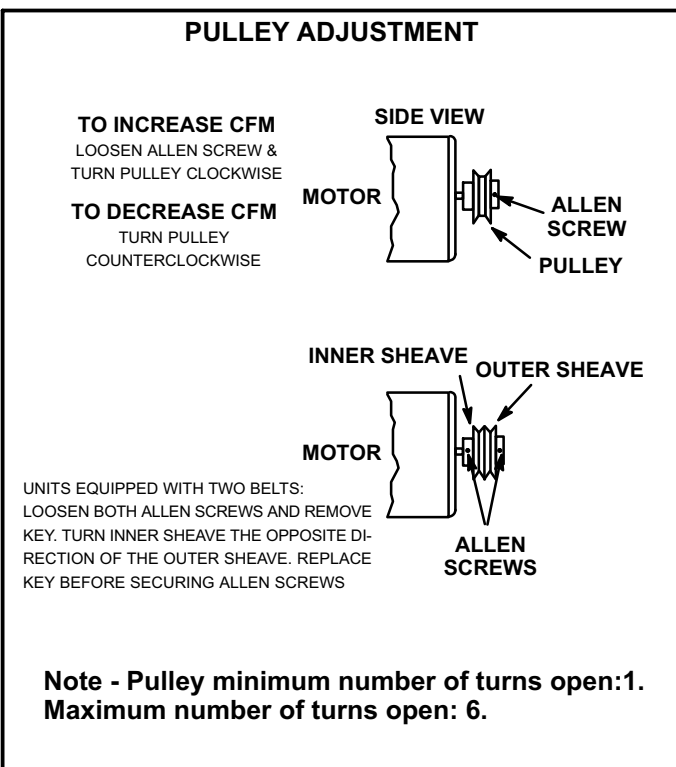

FIGURE 30

E-Optional Power Exhaust Blowers

- 1-Determine the power exhaust CFM in the same manner as the supply CFM with one exception: measure the return duct static pressure instead of total external pressure. Use Page 24 through Page 27.
- 2-The RPM can be adjusted at the motor pulley. Loosen Allen screw and turn adjustable pulley clockwise to increase CFM. Turn counterclockwise to decrease CFM. See figure 25.

F-Field-Furnished Blower Drives

For field-furnished blower drives, use Page 22 through Page 27 to determine BHP and RPM required. Reference Page 30 for supply air blower and high static power exhaust fan drive kit specifications. Reference tables 5 and 6 to determine the manufacturer's model number.

BLOWER DATA

BLOWER TABLE INCLUDES RESISTANCE FOR BASE UNIT ONLY WITH DRY INDOOR COIL AND AIR FILTERS IN PLACE

Add factory installed options air resistance, then determine from blower table blower motor output and drive kit required.

See page 28 for horizontal configured unit air resistance.

See page 29 for factory installed options air resistance data.

See page 30 for factory installed drive kit specifications.

TOTAL STATIC PRESSURE - 0.2 Thru 2.4 in. w.g. For 2.6 thru 4.6 in. w.g., see next page

Air Volume cfm	0.2		0.4		0.6		0.8		1.0		1.2		1.4		1.6		1.8		2.0		2.2		2.4	
	RPM	BHP	RPM	BHP	RPM	BHP	RPM	BHP	RPM	BHP	RPM	BHP	RPM	BHP	RPM	BHP	RPM	BHP	RPM	BHP	RPM	BHP	RPM	BHP
8000	---	---	---	---	562	0.90	593	1.76	625	2.59	658	3.37	692	4.11	728	4.81	765	5.48	802	6.14	838	6.80	873	7.46
8500	---	---	539	0.45	569	1.31	600	2.16	632	2.97	664	3.75	699	4.48	735	5.17	772	5.84	808	6.51	844	7.17	879	7.83
9000	---	---	547	0.87	576	1.73	607	2.57	639	3.38	672	4.14	706	4.87	743	5.56	779	6.23	815	6.90	851	7.56	885	8.22
9500	526	0.47	555	1.32	584	2.16	615	3.00	647	3.80	680	4.56	715	5.29	751	5.97	787	6.65	823	7.32	858	7.99	892	8.65
10,000	535	0.94	563	1.78	593	2.62	624	3.45	655	4.25	689	5.01	724	5.72	760	6.41	796	7.09	831	7.76	865	8.44	899	9.11
10,500	544	1.42	572	2.26	602	3.09	633	3.92	665	4.71	698	5.47	733	6.19	769	6.88	805	7.56	840	8.24	874	8.93	906	9.60
11,000	553	1.92	582	2.75	612	3.59	642	4.41	675	5.21	708	5.96	744	6.68	779	7.37	815	8.06	849	8.75	882	9.44	914	10.12
11,500	564	2.44	592	3.27	622	4.11	653	4.93	685	5.72	719	6.48	754	7.20	790	7.89	825	8.59	859	9.29	891	9.99	922	10.67
12,000	574	2.98	603	3.81	633	4.65	664	5.47	697	6.27	731	7.02	766	7.74	801	8.45	835	9.16	869	9.87	900	10.57	930	11.25
12,500	585	3.55	614	4.38	644	5.22	676	6.04	708	6.84	743	7.59	778	8.32	813	9.03	846	9.75	879	10.48	910	11.18	939	11.86
13,000	597	4.13	626	4.97	656	5.81	688	6.64	721	7.44	756	8.20	790	8.93	825	9.66	858	10.39	889	11.12	919	11.83	948	12.51
13,500	609	4.73	638	5.58	669	6.44	701	7.28	734	8.07	769	8.84	803	9.58	837	10.32	869	11.06	900	11.80	929	12.51	957	13.19
14,000	622	5.34	651	6.21	682	7.09	715	7.95	748	8.76	783	9.53	817	10.28	850	11.02	881	11.77	911	12.51	939	13.22	966	13.91
14,500	635	5.98	665	6.88	696	7.79	729	8.67	763	9.49	797	10.27	830	11.02	863	11.77	893	12.52	922	13.26	950	13.97	976	14.66
15,000	648	6.67	679	7.61	711	8.55	745	9.44	778	10.27	812	11.05	845	11.81	876	12.55	905	13.30	933	14.04	960	14.75	986	15.45
15,500	663	7.42	694	8.40	727	9.35	760	10.25	794	11.09	827	11.87	859	12.62	889	13.36	918	14.11	945	14.85	971	15.56	996	16.28
16,000	679	8.23	710	9.24	743	10.21	777	11.12	810	11.95	842	12.72	873	13.46	902	14.20	930	14.95	956	15.68	981	16.41	1006	17.15
16,500	695	9.11	727	10.14	760	11.11	793	12.01	826	12.83	857	13.60	887	14.33	915	15.06	942	15.81	967	16.56	992	17.30	1016	18.06
17,000	712	10.04	745	11.08	778	12.05	810	12.94	842	13.74	872	14.49	901	15.22	928	15.95	954	16.70	979	17.46	1003	18.23	1027	19.02
17,500	730	11.02	763	12.06	795	13.02	827	13.88	858	14.68	888	15.41	915	16.13	941	16.87	967	17.63	991	18.41	1015	19.21	1038	20.03
18,000	748	12.04	781	13.07	813	14.00	844	14.85	874	15.63	903	16.36	929	17.07	955	17.81	979	18.59	1003	19.41	1026	20.24	1049	21.10
18,500	767	13.10	799	14.10	831	15.02	861	15.85	890	16.61	917	17.33	943	18.05	968	18.81	992	19.62	1015	20.46	1038	21.34	1060	22.23
19,000	786	14.20	818	15.17	849	16.06	878	16.87	906	17.62	932	18.34	957	19.08	981	19.86	1005	20.70	1028	21.59	1050	22.50	1072	23.42
19,500	806	15.32	837	16.26	866	17.13	895	17.92	922	18.66	947	19.40	971	20.17	995	20.99	1018	21.86	1040	22.78	1063	23.72	1084	24.67
20,000	825	16.48	855	17.39	884	18.23	911	19.01	937	19.75	962	20.51	985	21.32	1008	22.17	1031	23.09	1053	24.04	1075	25.01	1097	25.98
20,500	845	17.67	874	18.55	902	19.37	928	20.13	953	20.89	976	21.68	1000	22.53	1022	23.43	1045	24.38	1067	25.37	1088	26.37	1110	27.35
21,000	864	18.89	892	19.74	919	20.53	944	21.30	968	22.09	991	22.92	1014	23.80	1036	24.75	1059	25.75	1080	26.77	1102	27.79	1123	28.78
21,500	883	20.13	910	20.95	936	21.73	960	22.52	984	23.34	1006	24.22	1029	25.15	1051	26.15	1073	27.19	1094	28.24	1116	29.27	1137	30.26
22,000	902	21.38	928	22.18	953	22.98	976	23.80	999	24.66	1021	25.59	1044	26.59	1066	27.64	1087	28.71	1109	29.77	1130	30.80	1151	31.79
22,500	921	22.65	945	23.46	969	24.28	992	25.14	1015	26.06	1037	27.05	1059	28.11	1081	29.20	1102	30.29	1123	31.36	1144	32.39	1165	33.37

BLOWER DATA

BLOWER TABLE INCLUDES RESISTANCE FOR BASE UNIT ONLY WITH DRY INDOOR COIL AND AIR FILTERS IN PLACE

Add factory installed options air resistance, then determine from blower table blower motor output and drive kit required.

See page 28 for horizontal configured unit air resistance.

See page 29 for factory installed options air resistance data.

See page 30 for factory installed drive kit specifications.

TOTAL STATIC PRESSURE - 2.6 Thru 4.6 in. w.g. For .2 thru 2.4 in. w.g., see previous page

Air Volume cfm	2.6		2.8		3.0		3.2		3.4		3.6		3.8		4.0		4.2		4.4		4.6	
	RPM	BHP	RPM	BHP	RPM	BHP	RPM	BHP	RPM	BHP	RPM	BHP	RPM	BHP	RPM	BHP	RPM	BHP	RPM	BHP	RPM	BHP
8000	908	8.1	940	8.72	970	9.33	1000	9.95	1029	10.59	1057	11.25	1084	11.91	1110	12.60	1136	13.31	1161	14.01	1188	14.71
8500	913	8.47	944	9.10	975	9.73	1004	10.36	1032	11.00	1059	11.66	1086	12.35	1113	13.06	1139	13.79	1165	14.54	1191	15.30
9000	918	8.87	949	9.51	979	10.15	1007	10.78	1035	11.43	1062	12.10	1089	12.81	1115	13.54	1141	14.28	1168	15.04	1194	15.83
9500	924	9.30	954	9.95	983	10.59	1011	11.24	1038	11.89	1065	12.58	1092	13.30	1118	14.03	1144	14.79	1170	15.56	1197	16.36
10,000	930	9.76	960	10.42	988	11.07	1015	11.72	1042	12.39	1068	13.08	1095	13.81	1121	14.55	1147	15.31	1173	16.09	1199	16.90
10,500	937	10.26	966	10.91	994	11.57	1020	12.24	1046	12.92	1072	13.62	1098	14.35	1124	15.10	1150	15.86	1176	16.65	1202	17.45
11,000	944	10.78	972	11.44	999	12.11	1025	12.79	1051	13.48	1076	14.19	1102	14.93	1128	15.68	1153	16.44	1178	17.22	1204	18.02
11,500	951	11.33	979	12.00	1005	12.68	1031	13.37	1056	14.08	1081	14.80	1106	15.54	1131	16.29	1156	17.05	1181	17.82	1207	18.61
12,000	959	11.92	986	12.6	1012	13.29	1037	13.99	1062	14.71	1086	15.44	1111	16.18	1135	16.93	1160	17.69	1185	18.46	1210	19.25
12,500	967	12.54	993	13.23	1018	13.93	1043	14.65	1068	15.38	1092	16.12	1116	16.87	1140	17.62	1164	18.37	1189	19.14	1214	19.92
13,000	975	13.19	1001	13.89	1026	14.61	1050	15.34	1074	16.09	1098	16.84	1121	17.59	1145	18.34	1169	19.09	1193	19.85	1218	20.64
13,500	983	13.88	1008	14.59	1033	15.33	1057	16.08	1081	16.84	1104	17.60	1127	18.36	1151	19.11	1174	19.85	1198	20.61	1223	21.40
14,000	992	14.61	1017	15.33	1041	16.09	1064	16.86	1088	17.63	1111	18.40	1134	19.16	1157	19.91	1180	20.66	1204	21.42	1229	22.21
14,500	1001	15.37	1025	16.12	1049	16.89	1072	17.68	1095	18.47	1118	19.24	1141	20.00	1163	20.75	1187	21.50	1210	22.26	1235	23.05
15,000	1010	16.18	1034	16.94	1057	17.73	1080	18.54	1103	19.34	1125	20.12	1148	20.88	1170	21.63	1193	22.38	1217	23.14	1242	23.94
15,500	1020	17.03	1043	17.81	1066	18.62	1089	19.44	1111	20.25	1133	21.04	1156	21.80	1178	22.55	1201	23.29	1224	24.06	1249	24.88
16,000	1029	17.92	1052	18.73	1075	19.56	1097	20.39	1120	21.20	1142	21.99	1164	22.75	1186	23.50	1209	24.25	1232	25.03	1258	25.86
16,500	1039	18.86	1062	19.69	1084	20.54	1107	21.37	1128	22.19	1150	22.98	1172	23.74	1194	24.49	1217	25.25	1241	26.05	1266	26.89
17,000	1050	19.85	1072	20.70	1094	21.56	1116	22.40	1138	23.22	1159	24.01	1181	24.77	1203	25.53	1226	26.30	1250	27.11	1275	27.97
17,500	1060	20.89	1082	21.76	1104	22.62	1126	23.47	1147	24.29	1169	25.07	1190	25.84	1213	26.61	1236	27.40	1260	28.22	1285	29.10
18,000	1071	21.99	1093	22.87	1115	23.74	1136	24.58	1157	25.40	1179	26.19	1200	26.96	1223	27.74	1246	28.54	1270	29.38	1296	30.27
18,500	1082	23.14	1104	24.03	1125	24.90	1147	25.75	1168	26.56	1189	27.35	1211	28.13	1233	28.92	1256	29.73	1281	30.58	1306	31.48
19,000	1094	24.34	1115	25.25	1136	26.12	1158	26.96	1179	27.78	1200	28.57	1222	29.35	1244	30.14	1267	30.96	1292	31.81	1317	32.71
19,500	1106	25.61	1127	26.52	1148	27.39	1169	28.23	1190	29.04	1211	29.83	1233	30.61	1255	31.40	1279	32.21	1303	33.06	1329	33.95
20,000	1118	26.93	1139	27.84	1160	28.71	1181	29.55	1202	30.35	1223	31.13	1245	31.91	1267	32.69	1290	33.50	1315	34.34	---	---
20,500	1131	28.30	1152	29.21	1172	30.08	1193	30.90	1214	31.70	1235	32.47	1257	33.23	1279	34.01	---	---	---	---	---	---
21,000	1144	29.73	1165	30.63	1185	31.48	1206	32.30	1226	33.08	1247	33.84	---	---	---	---	---	---	---	---	---	---
21,500	1157	31.20	1178	32.09	1198	32.93	1218	33.73	1239	34.49	---	---	---	---	---	---	---	---	---	---	---	---
22,000	1171	32.72	1191	33.59	1211	34.41	---	---	---	---	---	---	---	---	---	---	---	---	---	---	---	---
22,500	1185	34.28	---	---	---	---	---	---	---	---	---	---	---	---	---	---	---	---	---	---	---	---

BLOWER DATA

POWER EXHAUST FANS

¹ 50% HIGH STATIC OPERATION, NO ERW

Air Volume cfm	Return Duct Negative Static Pressure - Inches Water Gauge (Pa)																					
	0		0.1		0.2		0.3		0.4		0.5		0.6		0.7		0.8		0.9		1.0	
	RPM	BHP	RPM	BHP	RPM	BHP	RPM	BHP	RPM	BHP	RPM	BHP	RPM	BHP	RPM	BHP	RPM	BHP	RPM	BHP	RPM	BHP
4000	410	0.75	465	1.00	520	1.25	575	1.50	630	1.80	685	2.15	740	2.50	795	2.85	845	3.25	900	3.70	955	4.15
4500	460	1.10	510	1.35	560	1.60	610	1.90	655	2.20	705	2.55	755	2.90	805	3.30	850	3.70	900	4.15	945	4.55
5000	510	1.50	555	1.75	600	2.05	645	2.40	690	2.70	735	3.10	775	3.40	820	3.85	865	4.25	910	4.70	950	5.15
5500	560	2.00	600	2.25	645	2.60	685	2.95	725	3.30	765	3.70	805	4.05	845	4.50	885	4.90	925	5.35	965	5.85
6000	610	2.55	650	2.90	685	3.25	725	3.60	760	3.95	800	4.40	835	4.80	870	5.20	910	5.65	945	6.10	980	6.55
6500	665	3.30	700	3.65	730	3.95	765	4.35	800	4.75	835	5.20	870	5.60	905	6.10	935	6.50	970	7.00	1005	7.50
7000	715	4.10	745	4.45	780	4.90	810	5.25	840	5.65	875	6.15	905	6.55	940	7.05	970	7.50	1000	8.00	1030	8.50
7500	765	5.05	795	5.45	825	5.85	855	6.30	885	6.75	915	7.20	945	7.65	975	8.15	---	---	---	---	---	---
8000	815	6.10	845	6.55	870	6.95	900	7.45	930	7.95	955	8.35	---	---	---	---	---	---	---	---	---	---
8500	865	7.30	895	7.80	920	8.25	---	---	---	---	---	---	---	---	---	---	---	---	---	---	---	---

POWER EXHAUST FANS

¹ 100% HIGH STATIC OPERATION, NO ERW

Air Volume cfm	Return Duct Negative Static Pressure - Inches Water Gauge (Pa)																					
	0		0.1		0.2		0.3		0.4		0.5		0.6		0.7		0.8		0.9		1.0	
	RPM	BHP	RPM	BHP	RPM	BHP	RPM	BHP	RPM	BHP	RPM	BHP	RPM	BHP	RPM	BHP	RPM	BHP	RPM	BHP	RPM	BHP
8000	410	1.45	450	1.70	495	2.05	535	2.35	580	2.70	625	3.10	665	3.50	710	3.95	750	4.40	790	4.85	835	5.35
8500	435	1.70	475	2.00	515	2.35	555	2.70	595	3.05	635	3.45	675	3.85	715	4.30	755	4.75	795	5.25	835	5.75
9000	460	2.05	495	2.35	535	2.70	575	3.05	610	3.40	650	3.85	690	4.30	725	4.70	765	5.20	800	5.65	840	6.20
9500	485	2.40	520	2.70	555	3.05	595	3.45	630	3.85	665	4.25	700	4.70	740	5.20	775	5.65	810	6.15	845	6.65
10,000	510	2.80	545	3.15	580	3.50	615	3.90	650	4.35	680	4.70	715	5.15	750	5.65	785	6.15	820	6.65	855	7.20
10,500	535	3.20	570	3.60	600	3.95	635	4.40	665	4.80	700	5.25	730	5.70	765	6.20	795	6.65	830	7.20	860	7.70
11,000	560	3.70	590	4.05	625	4.50	655	4.90	685	5.35	720	5.85	750	6.30	780	6.75	810	7.25	840	7.75	875	8.40
11,500	585	4.20	615	4.60	645	5.05	675	5.45	705	5.90	735	6.40	765	6.90	795	7.40	825	7.90	855	8.45	885	9.00
12,000	610	4.80	640	5.20	670	5.70	700	6.15	725	6.55	755	7.05	785	7.60	815	8.10	840	8.60	870	9.15	900	9.75
12,500	635	5.40	665	5.90	690	6.30	720	6.80	750	7.30	775	7.75	805	8.30	830	8.80	860	9.40	885	9.90	915	10.55
13,000	660	6.10	690	6.60	715	7.00	740	7.45	770	8.05	795	8.50	820	9.00	850	9.65	875	10.15	900	10.70	930	11.35
13,500	690	6.90	715	7.35	740	7.80	765	8.30	790	8.80	815	9.30	840	9.85	865	10.40	895	11.05	920	11.65	945	12.20
14,000	715	7.65	740	8.15	765	8.65	785	9.10	810	9.60	835	10.15	860	10.70	885	11.30	910	11.90	935	12.50	960	13.10
14,500	740	8.50	765	9.05	785	9.45	810	10.00	835	10.60	860	11.20	880	11.65	905	12.25	930	12.90	955	13.55	975	14.05
15,000	765	9.40	785	9.85	810	10.45	835	11.05	855	11.50	880	12.15	905	12.75	925	13.30	950	13.95	970	14.50	995	15.20
15,500	790	10.35	810	10.85	835	11.45	855	11.95	880	12.60	900	13.15	925	13.80	945	14.35	970	15.05	990	15.65	1015	16.35
16,000	815	11.40	835	11.90	860	12.55	880	13.10	900	13.65	925	14.35	945	14.90	965	15.50	990	16.20	1010	16.85	---	---
16,500	840	12.50	860	13.05	885	13.70	905	14.30	925	14.85	945	15.45	965	16.05	990	16.80	---	---	---	---	---	---
17,000	865	13.65	885	14.20	905	14.80	925	15.40	950	16.15	970	16.80	---	---	---	---	---	---	---	---	---	---
17,500	890	14.85	910	15.50	930	16.10	950	16.75	---	---	---	---	---	---	---	---	---	---	---	---	---	---
18,000	915	16.15	935	16.80	---	---	---	---	---	---	---	---	---	---	---	---	---	---	---	---	---	---

NOTE - See page 30 for factory installed drive kit specifications.

¹ Size power exhaust fans in economizer mode to minimize building static pressure during free[®] cooling.

BLOWER DATA

POWER EXHAUST FANS

¹ 50% HIGH STATIC OPERATION WITH ERW (BY-PASS DAMPERS CLOSED)

Air Volume cfm	Return Duct Negative Static Pressure - Inches Water Gauge (Pa)																					
	0		0.1		0.2		0.3		0.4		0.5		0.6		0.7		0.8		0.9		1.0	
	RPM	BHP	RPM	BHP	RPM	BHP	RPM	BHP	RPM	BHP	RPM	BHP	RPM	BHP	RPM	BHP	RPM	BHP	RPM	BHP	RPM	BHP
2500	390	0.35	460	0.50	530	0.70	600	0.90	670	1.15	735	1.40	805	1.70	870	2.00	935	2.35	1005	2.75	1070	3.10
3000	465	0.60	525	0.75	585	1.00	645	1.20	700	1.45	760	1.75	815	2.05	870	2.35	930	2.70	985	3.05	1040	3.45
3500	545	0.95	595	1.15	645	1.35	695	1.60	745	1.90	795	2.20	845	2.50	895	2.85	945	3.20	990	3.55	1040	3.95
4000	620	1.35	665	1.60	710	1.90	755	2.15	800	2.45	840	2.75	885	3.10	930	3.45	975	3.80	1015	4.15	1060	4.60
4500	700	1.95	740	2.25	780	2.55	820	2.85	855	3.10	895	3.45	935	3.80	975	4.20	1015	4.60	1050	4.95	---	---
5000	775	2.70	815	3.00	850	3.30	885	3.65	920	4.00	955	4.35	990	4.70	1025	5.10	1060	5.50	---	---	---	---
5500	855	3.60	885	3.90	920	4.25	950	4.60	985	5.00	1015	5.35	1050	5.75	---	---	---	---	---	---	---	---
6000	935	4.70	965	5.05	990	5.35	1020	5.75	1050	6.15	---	---	---	---	---	---	---	---	---	---	---	---

POWER EXHAUST FANS

¹ 100% HIGH STATIC OPERATION WITH ERW (BY-PASS DAMPERS CLOSED)

Air Volume cfm	Return Duct Negative Static Pressure - Inches Water Gauge (Pa)																					
	0		0.1		0.2		0.3		0.4		0.5		0.6		0.7		0.8		0.9		1.0	
	RPM	BHP	RPM	BHP	RPM	BHP	RPM	BHP	RPM	BHP	RPM	BHP	RPM	BHP	RPM	BHP	RPM	BHP	RPM	BHP	RPM	BHP
5000	445	0.85	505	1.15	565	1.45	625	1.85	680	2.20	740	2.65	800	3.15	855	3.60	910	4.15	970	4.75	1025	5.30
5500	490	1.15	545	1.45	600	1.80	650	2.15	705	2.55	760	3.05	810	3.50	865	4.00	915	4.55	970	5.15	1020	5.70
6000	535	1.45	585	1.80	635	2.15	685	2.60	735	3.00	780	3.45	830	3.95	880	4.50	925	5.00	975	5.60	1020	6.15
6500	580	1.85	625	2.20	670	2.60	715	3.00	760	3.45	805	3.95	850	4.45	895	4.95	940	5.50	985	6.10	1030	6.75
7000	625	2.35	665	2.70	710	3.15	750	3.55	795	4.05	835	4.50	880	5.05	920	5.60	960	6.15	1005	6.80	1045	7.40
7500	670	2.90	710	3.30	750	3.75	790	4.20	825	4.65	865	5.15	905	5.70	945	6.25	985	6.85	1025	7.50	1060	8.05
8000	715	3.50	750	3.90	790	4.40	825	4.85	860	5.35	900	5.90	935	6.45	975	7.05	1010	7.65	1045	8.25	---	---
8500	760	4.20	795	4.65	830	5.15	865	5.65	900	6.20	935	6.75	970	7.30	1000	7.85	1035	8.45	1070	9.10	---	---
9000	800	4.90	835	5.45	870	5.95	900	6.45	935	7.05	970	7.65	1000	8.20	1035	8.85	1065	9.40	---	---	---	---
9500	845	5.80	880	6.35	910	6.85	940	7.40	975	8.05	1005	8.60	1035	9.20	1065	9.80	---	---	---	---	---	---
10,000	890	6.75	920	7.30	950	7.85	980	8.45	1010	9.05	1040	9.65	1070	10.30	---	---	---	---	---	---	---	---
10,500	935	7.85	965	8.45	995	9.05	1020	9.60	1050	10.25	---	---	---	---	---	---	---	---	---	---	---	---
11,000	980	9.00	1010	9.65	1035	10.25	1060	10.80	---	---	---	---	---	---	---	---	---	---	---	---	---	---
11,500	1025	10.30	1050	10.90	---	---	---	---	---	---	---	---	---	---	---	---	---	---	---	---	---	---
12,000	1070	11.75	---	---	---	---	---	---	---	---	---	---	---	---	---	---	---	---	---	---	---	---

NOTE - See page 30 for factory installed drive kit specifications.

¹ Size power exhaust fans with ERW in economizer mode to minimize building static pressure during free" cooling.

BLOWER DATA

POWER EXHAUST FANS

¹ 50% HIGH STATIC OPERATION WITH ERW IN ECONOMIZER MODE (BY-PASS DAMPERS OPEN)

Air Volume cfm	Return Duct Negative Static Pressure - Inches Water Gauge (Pa)																					
	0		0.1		0.2		0.3		0.4		0.5		0.6		0.7		0.8		0.9		1.0	
	RPM	BHP	RPM	BHP	RPM	BHP	RPM	BHP	RPM	BHP	RPM	BHP	RPM	BHP	RPM	BHP	RPM	BHP	RPM	BHP	RPM	BHP
3500	380	0.55	435	0.70	495	0.90	555	1.10	615	1.35	675	1.60	730	1.85	790	2.15	845	2.45	900	2.80	960	3.15
4000	430	0.80	485	1.00	535	1.20	585	1.40	640	1.65	690	1.95	740	2.20	790	2.50	845	2.85	895	3.20	945	3.55
4500	485	1.10	530	1.30	575	1.55	625	1.80	670	2.05	715	2.35	760	2.65	805	2.95	855	3.30	900	3.65	945	4.00
5000	540	1.55	580	1.75	620	2.00	665	2.30	705	2.55	745	2.85	790	3.20	830	3.50	870	3.85	910	4.15	950	4.55
5500	590	2.05	630	2.30	670	2.60	705	2.85	745	3.15	780	3.45	820	3.80	855	4.10	895	4.50	930	4.80	970	5.25
6000	645	2.65	680	2.90	715	3.20	750	3.50	785	3.85	820	4.15	855	4.50	890	4.85	925	5.25	960	5.65	995	6.05
6500	700	3.35	730	3.65	765	4.00	795	4.30	830	4.65	860	5.00	890	5.30	925	5.70	955	6.10	990	6.50	1020	6.90
7000	755	4.20	785	4.55	815	4.90	845	5.20	875	5.60	905	5.95	935	6.35	960	6.65	990	7.05	1020	7.45	1050	7.90
7500	805	5.15	835	5.50	865	5.90	890	6.20	920	6.60	945	6.95	975	7.40	1000	7.75	1030	8.20	1060	8.65	---	---
8000	860	6.25	885	6.60	915	7.05	940	7.40	965	7.80	990	8.15	1020	8.65	1045	9.05	1070	9.45	---	---	---	---
8500	915	7.55	940	7.90	965	8.35	990	8.75	1015	9.15	1040	9.60	1060	9.95	---	---	---	---	---	---	---	---

POWER EXHAUST FANS

¹ 100% HIGH STATIC OPERATION WITH ERW IN ECONOMIZER MODE (BY-PASS DAMPERS OPEN)

Air Volume cfm	Return Duct Negative Static Pressure - Inches Water Gauge (Pa)																					
	0		0.1		0.2		0.3		0.4		0.5		0.6		0.7		0.8		0.9		1.0	
	RPM	BHP	RPM	BHP	RPM	BHP	RPM	BHP	RPM	BHP	RPM	BHP	RPM	BHP	RPM	BHP	RPM	BHP	RPM	BHP	RPM	BHP
7000	415	1.15	470	1.50	520	1.80	570	2.10	620	2.50	675	2.90	725	3.35	775	3.80	825	4.30	875	4.80	925	5.35
7500	445	1.45	495	1.75	540	2.05	590	2.45	640	2.85	685	3.25	735	3.70	780	4.15	825	4.65	875	5.20	920	5.70
8000	475	1.75	520	2.05	565	2.40	610	2.80	655	3.20	700	3.65	745	4.10	790	4.55	835	5.10	880	5.60	920	6.10
8500	505	2.10	545	2.40	590	2.80	635	3.25	675	3.60	715	4.05	760	4.55	800	5.00	845	5.55	885	6.05	925	6.60
9000	535	2.50	575	2.85	615	3.25	655	3.65	695	4.10	735	4.55	775	5.00	815	5.50	855	6.05	895	6.60	935	7.15
9500	565	2.95	600	3.30	640	3.70	680	4.15	715	4.55	755	5.05	790	5.50	830	6.05	870	6.60	905	7.15	945	7.75
10,000	595	3.45	630	3.80	665	4.20	700	4.65	740	5.15	775	5.65	810	6.10	845	6.65	880	7.15	920	7.80	955	8.35
10,500	625	4.00	660	4.40	690	4.80	725	5.25	760	5.75	795	6.25	830	6.75	865	7.30	900	7.90	935	8.50	965	9.00
11,000	655	4.60	685	4.95	720	5.45	750	5.90	785	6.40	820	6.95	850	7.45	885	8.05	915	8.55	950	9.20	980	9.75
11,500	680	5.15	715	5.65	745	6.10	775	6.60	810	7.15	840	7.65	870	8.20	905	8.80	935	9.40	965	9.95	995	10.55
12,000	710	5.85	740	6.35	775	6.90	805	7.40	835	7.95	865	8.50	895	9.05	925	9.65	955	10.25	985	10.85	1015	11.50
12,500	740	6.65	770	7.15	800	7.70	830	8.25	860	8.80	885	9.30	915	9.90	945	10.50	975	11.15	1005	11.80	1030	12.35
13,000	770	7.50	800	8.05	825	8.50	855	9.10	885	9.70	910	10.20	940	10.85	965	11.40	995	12.10	1020	12.65	1050	13.40
13,500	800	8.40	830	9.00	855	9.50	880	10.00	910	10.65	935	11.20	965	11.90	990	12.50	1015	13.10	1045	13.85	---	---
14,000	830	9.35	855	9.90	885	10.55	910	11.10	935	11.70	960	12.30	985	12.90	1010	13.50	1040	14.25	1065	14.90	---	---
14,500	860	10.40	885	11.00	910	11.55	935	12.15	960	12.75	985	13.40	1010	14.05	1035	14.70	1060	15.40	---	---	---	---
15,000	890	11.55	915	12.15	940	12.75	965	13.40	985	13.95	1010	14.60	1035	15.30	1060	16.00	---	---	---	---	---	---
15,500	920	12.75	945	13.40	965	13.90	990	14.60	1015	15.30	1035	15.85	1060	16.60	---	---	---	---	---	---	---	---
16,000	950	14.00	970	14.55	995	15.25	1020	16.00	1040	16.60	1065	17.35	---	---	---	---	---	---	---	---	---	---
16,500	980	15.35	1000	15.95	1025	16.70	1045	17.30	1065	17.95	---	---	---	---	---	---	---	---	---	---	---	---
17,000	1010	16.80	1030	17.45	1050	18.10	---	---	---	---	---	---	---	---	---	---	---	---	---	---	---	---

NOTE - See page 30 for factory installed drive kit specifications.

¹ Size power exhaust fans in economizer mode to minimize building static pressure during free" cooling.

BLOWER DATA

POWER EXHAUST FANS

STANDARD STATIC (¹ TWO FAN OPERATION)

Return Duct Negative Static Pressure Inches Water Gauge	Air Volume cfm	Return Duct Negative Static Pressure Inches Water Gauge	Air Volume cfm
0	12,100	0.50	5700
0.05	11,600	0.55	5000
0.10	11,150	0.60	4300
0.15	10,600	0.65	3800
0.20	10,100	0.70	3400
0.25	9500	0.75	3000
0.30	8900	0.80	2500
0.35	8200	0.85	2300
0.40	7400	0.90	2000
0.45	6500		

¹ For one fan operation, use half of the air volume value.

OUTDOOR AIR PERCENTAGE VS. FRESH AIR DAMPER ANGLE - Less ERW

Fresh Air Damper Opening Angle	Percentage of Outdoor Air Available at Various Return Duct Static Pressures - in. w.g.			
	0.2	0.4	0.6	0.8
10°	5%	11%	16%	21%
20°	19%	25%	30%	36%
30°	34%	39%	44%	50%
40°	48%	53%	59%	64%
50°	62%	68%	73%	79%
60°	77%	82%	87%	93%
70°	91%	96%	100%	100%
80°	100%	100%	100%	100%

NOTE - Outdoor air percentage will vary when a variable frequency drive (VFD) drive is used on the supply air blower.

OUTDOOR AIR PERCENTAGE VS. FRESH AIR DAMPER ANGLE - With ERW

¹ ERW Static Pressure in. w.g.	Percentage of Outdoor Air Available at Various Return Duct Static Pressures																		
	0 Return Duct Static						0.2 Return Duct Static						0.4 Return Duct Static						
	1.2	1.0	0.8	0.6	0.4	0.2	1.2	1.0	0.8	0.6	0.4	0.2	1.2	1.0	0.8	0.6	0.4	0.2	
Fresh Air Damper Opening Angle	10°	---	---	---	---	---	---	---	---	---	---	---	---	---	---	---	---	---	
	20°	9%	4%	---	---	---	---	14%	9%	4%	---	---	---	19%	14%	9%	4%	---	---
	30°	23%	18%	13%	8%	2%	---	28%	23%	18%	13%	8%	2%	34%	28%	23%	18%	13%	8%
	40°	38%	32%	27%	22%	17%	11%	43%	38%	32%	27%	22%	17%	48%	43%	38%	32%	27%	22%
	50°	52%	46%	41%	36%	31%	25%	57%	52%	46%	41%	36%	31%	62%	57%	52%	46%	41%	36%
	60°	66%	61%	55%	50%	45%	39%	71%	66%	61%	55%	50%	45%	77%	71%	66%	61%	55%	50%
	70°	81%	75%	70%	64%	59%	54%	86%	81%	75%	70%	64%	59%	91%	86%	81%	75%	70%	64%
	80°	95%	89%	84%	78%	73%	68%	100%	95%	89%	84%	78%	73%	100%	100%	95%	89%	84%	78%
¹ ERW Static Pressure in. w.g.	Percentage of Outdoor Air Available at Various Return Duct Static Pressures																		
	0.6 Return Duct Static							0.8 Return Duct Static											
	1.2	1.0	0.8	0.6	0.4	0.2	1.2	1.0	0.8	0.6	0.4	0.2	1.2	1.0	0.8	0.6	0.4	0.2	
Fresh Air Damper Opening Angle	10°	---	---	---	---	---	---	---	---	---	---	---	---	---	---	---	---	---	
	20°	25%	19%	14%	9%	4%	---	30%	25%	19%	14%	9%	4%	---	---	---	---	---	
	30°	39%	34%	28%	23%	18%	13%	44%	39%	34%	28%	23%	18%	49%	44%	39%	34%	29%	
	40°	54%	48%	43%	38%	32%	27%	59%	54%	48%	43%	38%	32%	64%	59%	54%	48%	43%	
	50°	68%	62%	57%	52%	46%	41%	73%	68%	62%	57%	52%	46%	78%	73%	68%	62%	57%	
	60°	84%	77%	71%	66%	61%	55%	87%	84%	77%	71%	66%	61%	91%	87%	84%	77%	71%	
	70°	97%	91%	86%	81%	75%	70%	100%	97%	91%	86%	81%	75%	100%	100%	97%	91%	86%	
	80°	100%	100%	100%	95%	89%	84%	100%	100%	100%	100%	100%	100%	100%	100%	100%	95%	89%	

NOTE - Outdoor air percentage will vary when a variable frequency drive (VFD) drive is used on the supply air blower.

¹ See page 57 for Energy Recovery Wheel Specifications.

BLOWER DATA**AIR RESISTANCE****HORIZONTAL AIRFLOW APPLICATIONS**

Air Volume	Standard Static Power Exhaust fans or No Power Exhaust Fans	50% High Static Power Exhaust Fans	100% High Static Power Exhaust Fans
cfm	in. w.g.	in. w.g.	in. w.g.
10,000	.20	.23	.25
10,500	.20	.25	.30
11,000	.20	.25	.30
11,500	.20	.30	.40
12,000	.20	.33	.45
12,500	.20	.35	.50
13,000	.20	.38	.55
13,500	.25	.43	.60
14,000	.25	.45	.65
14,500	.25	.48	.70
15,000	.30	.55	.80
15,500	.30	.58	.85
16,000	.30	.63	.95
16,500	.30	.63	.95
17,000	.30	.68	1.05
17,500	.30	.70	1.10
18,000	.30	.75	1.20
18,500	.30	.78	1.25
19,000	.30	.83	1.35
19,500	.30	.83	1.40
20,000	.30	.90	1.50
20,500	.35	.94	1.60
21,000	.35	.98	1.70
21,500	.35	1.02	1.80
22,000	.35	1.04	1.90
22,500	.35	1.10	2.00

BLOWER DATA

FACTORY INSTALLED OPTIONS AIR RESISTANCE

ECONOMIZER RETURN AIR DAMPER WITH ERW

Outdoor Air Volume With ERW cfm	Return Duct Negative Static Pressure 0 in. w.g.				
	0.2	0.4	0.6	0.8	1.0
3250	0.32	0.12	---	---	---
3500	0.36	0.16	---	---	---
3750	0.40	0.20	---	---	---
4000	0.44	0.24	0.04	---	---
4250	0.48	0.28	0.08	---	---
4500	0.52	0.32	0.12	---	---
4750	0.57	0.37	0.17	---	---
5000	0.60	0.40	0.20	---	---
5250	0.65	0.45	0.25	0.05	---
5500	0.68	0.48	0.28	0.08	---
5750	0.73	0.53	0.33	0.13	---
6000	0.76	0.56	0.36	0.16	---
6250	0.81	0.61	0.41	0.21	0.01
6500	0.84	0.64	0.44	0.24	0.04
6750	0.89	0.69	0.49	0.29	0.09
7000	0.93	0.73	0.53	0.33	0.13
7250	0.97	0.77	0.57	0.37	0.17
7500	1.01	0.81	0.61	0.41	0.21
7750	1.05	0.85	0.65	0.45	0.25
8000	1.09	0.89	0.69	0.49	0.29
8250	1.13	0.93	0.73	0.53	0.33
8500	1.17	0.97	0.77	0.57	0.37
8750	1.21	1.01	0.81	0.61	0.41
9000	1.25	1.05	0.85	0.65	0.45

FACTORY INSTALLED OPTIONS ACCESSORY AIR RESISTANCE

Air Volume cfm	Gas Heat Exchanger		Electric Heat	Wet Indoor Coil	Humiditrol Condenser Reheat Coil	Econo mizer	Filters			
	Standard Heat	High Heat					MERV 8		MERV 13	
							2 inch	4 inch	2 inch	4 inch
	in. w.g.	in. w.g.					in. w.g.	in. w.g.	in. w.g.	in. w.g.
8000	0.04	0.04	0.07	0.16	---	---	0.03	0.05	0.11	0.06
9000	0.04	0.04	0.07	0.21	---	---	0.03	0.05	0.13	0.07
10,000	0.04	0.05	0.07	0.25	---	0.02	0.04	0.06	0.14	0.08
11,000	0.04	0.05	0.07	0.29	---	0.08	0.04	0.06	0.16	0.08
12,000	0.04	0.05	0.07	0.32	---	0.12	0.05	0.07	0.17	0.09
13,000	0.04	0.05	0.07	0.37	---	0.17	0.05	0.07	0.18	0.10
14,000	0.04	0.05	0.07	0.42	0.01	0.19	0.05	0.08	0.20	0.11
15,000	0.04	0.05	0.08	0.46	0.01	0.22	0.06	0.09	0.21	0.11
16,000	0.04	0.05	0.09	0.51	0.02	0.23	0.06	0.09	0.23	0.12
17,000	0.04	0.05	0.10	0.56	0.04	0.25	0.06	0.10	0.24	0.13
18,000	0.04	0.05	0.13	0.60	0.06	0.26	0.07	0.10	0.26	0.14
19,000	0.04	0.05	0.14	0.68	0.09	0.26	0.07	0.11	0.27	0.14
20,000	0.04	0.06	0.18	0.70	0.11	0.26	0.07	0.11	0.28	0.15
21,000	0.04	0.06	0.20	0.78	0.15	0.26	0.08	0.12	0.30	0.16
22,000	0.04	0.06	0.21	0.82	0.19	0.26	0.08	0.12	0.31	0.17

BLOWER DRIVE KITS

VARIABLE FREQUENCY DRIVE KIT SPECIFICATIONS

Nominal hp	Maximum hp	Drive Kit Number	RPM Range (Adjustable Pulley)
5	5.75	1	510 - 640
		2	630 - 760
7.5	8.63	3	635 - 770
		4	750 - 905
10	11.5	5	670 - 825
		4	750 - 905
		6	880 - 1050
15	17.25	7	745 - 900
		8	875 - 1045
		9	965 - 1190
20	23	10	825 - 1020
		11	1010 - 1240
25	28.75	12	930 - 1085
		13	1075 - 1285
30	34.5	13	1075 - 1285
		14	1150 - 1340

NOTE - Using total air volume and system static pressure requirements determine from blower performance tables rpm and motor output required. Maximum usable output of motors furnished are shown. In Canada, nominal motor hp is also maximum usable motor hp. If motors of comparable output are used, be sure to keep within the service factor limitations outlined on the motor nameplate.

For Variable Frequency Drive applications, nominal motor output is also maximum usable motor output.

HIGH STATIC POWER EXHAUST BLOWERS - DRIVE KIT SPECIFICATIONS

Nominal hp per blower	¹ Maximum hp per blower	RPM Range ³ Adjustable	Drive Kit Number		
			50% Applications Rear Position	² 100% Applications Order One Each:	
				Front Position	Rear Position
3	3.45	735-920	6(A)-B35	6(B)-B36	6(A)-B35
		690-845	5(A)-B35	5(B)-B36	5(A)-B35
5	5.75	795-975	3(A)-B35	3(B)-B36	3(A)-B35
		735-920	4(A)-B35	4(B)-B36	4(A)-B35
7.5	8.63	850-1065	1(A)-B35	1(B)-B36	1(A)-B35
		820-980	2(A)-B35	2(B)-B36	2(A)-B35

¹ In VFD applications, nominal motor output is also maximum usable motor output.

² Two drive kits are required for the same rpm, one for the front blower position and one for the rear blower position because of different belt length requirements.

³ Adjustable motor pulleys are factory set for maximum RPM in VFD applications.

**TABLE 5
SUPPLY AIR BLOWER DRIVE COMPONENT MANUFACTURER'S NUMBERS**

Drive No.	DRIVE COMPONENTS							
	MOTOR PULLEY		BLOWER PULLEY		BLOWER BUSHING		BELTS	
	OEM Part No.	Browning No.	OEM Part No.	Browning No.	OEM Part No.	Browning No.	OEM Part No.	Browning No.
1	P-8-2237	1VP62 X 1-1/8	78M9001	1B5V160	79M0601	B - 1-11/16	78M6401	5VX900
2	78M6901	1VP71 X 1-1/8	78M9001	1B5V160	79M0601	B - 1-11/16	78M6501	5VX930
3	100239-06	1VP71 X 1-3/8	78M9001	1B5V160	79M0601	B - 1-11/16	78M6401	5VX900
4	100239-06	1VP71 X 1-3/8	78M8801	1B5V136	79M0601	B - 1-11/16	78M6201	5VX860
5	78M7101	1VP65 X 1-3/8	78M8801	1B5V136	79M0601	B - 1-11/16	78M6101	5VX850
6	100239-05	1VP75 X 1-3/8	78M8701	1B5V124	79M0601	B - 1-11/16	78M6101	5VX850
7	78M7201	1VP71 X 1-5/8	78M8801	1B5V136	79M0601	B - 1-11/16	78M6101	5VX850
8	78M7401	1VP75 X 1-5/8	78M8701	1B5V124	79M0601	B - 1-11/16	78M5901	5VX830
9	103387-01	2VP65 X 1-5/8	103386-01	1B5V94	79M0601	B - 1-11/16	78M5601	5VX780
10	103384-01	2VP65 X 1-5/8	78M9901	2B5V110	79M0601	B - 1-11/16	78M5701	5VX800(2)
11	103384-01	2VP65 X 1-5/8	103385-01	2B5V90	79M0601	B - 1-11/16	78M5501	5VX750(2)
12	78M7801	2V68B80 X 1-7/8	78M8801	2B5V136	79M0601	B - 1-11/16	78M6101	5VX850(2)
13	78M7701	2V58B70 X 1-7/8	79M0201	2Q5V103	79M0801	Q - 1-11/16	78M5601	5VX780(2)
14	78M7801	2V68B80 X 1-7/8	78M9901	2B5V110	79M0601	B - 1-11/16	78M5801	5VX810(2)

**TABLE 6
POWER EXHAUST DRIVE COMPONENT MANUFACTURER'S NUMBERS**

Drive No.	DRIVE COMPONENTS					
	MOTOR PULLEY		BLOWER PULLEY		BELTS	
	Browning No.	OEM Part No.	Browning No.	OEM Part No.	Browning No.	OEM Part No.
1A	1VP60 x 1 3/8	78L5501	BK100 x 1 7/16	39L1301	BX68	88K3401
1B	1VP60 x 1 3/8	78L5501	BK100 x 1 7/16	39L1301	BX62	57A7701
2A	1VP60 x 1 3/8	78L5501	BK110 x 1 7/16	81M0401	BX70	31K9601
2B	1VP60 x 1 3/8	78L5501	BK110 x 1 7/16	81M0401	BX64	24L5001
3A	1VP56 x 1 1/8	P-8-1492	BK100 x 1 7/16	39L1301	BX68	88K3401
3B	1VP56 x 1 1/8	P-8-1492	BK100 x 1 7/16	39L1301	BX61	93J9801
4A	1VP60 x 1 1/8	41C1301	BK115 x 1 7/16	81M0501	BX71	31K9701
4B	1VP60 x 1 1/8	41C1301	BK115 x 1 7/16	81M0501	BX64	24L5001
5A	1VP56 x 7/8	P-8-1494	BK115 x 1 7/16	81M0501	BX71	31K9701
5B	1VP56 x 7/8	P-8-1494	BK115 x 1 7/16	81M0501	BX64	24L5001
6A	1VP60 x 7/8	80K5501	BK115 x 1 7/16	81M0501	BX71	31K9701
6B	1VP60 x 7/8	80K5501	BK115 x 1 7/16	81M0501	BX64	24L5001

NOTE - A drives for rear blower assembly; B drives for front blower assembly.

Cooling Start-Up

IMPORTANT-The crankcase heater must be energized for 24 hours before attempting to start compressor. Set control so there is no cooling demand to prevent compressors from operating. Apply power to unit.

NOTE - These units must not be used as a “construction heater” at any time during any phase of construction. Very low return air temperatures, harmful vapors and misplacement of the filters will damage the unit and its efficiency. Additionally, a unit which will be subject to cold temperatures when not in operation must have a vapor barrier installed to seal the duct connections. Failure to protect the unit from moisture laden air or harmful vapors (generated from the construction process and temporary combustion heating equipment) will cause corrosive condensation within the unit. Failure to properly protect the unit in this situation will cause electrical and electronic component failure and could affect the unit warranty status.

⚠ IMPORTANT

Three Phase Scroll Compressor Voltage Phasing

Three phase scroll compressors must be phased sequentially to ensure correct compressor and blower* rotation and operation. Compressor and blower are wired in phase at the factory. Power wires are color-coded as follows: line 1-red, line 2-yellow, line 3-blue.

1-Observe suction and discharge pressures and blower* rotation on unit start-up.

2-Suction pressure must drop, discharge pressure must rise, and blower* rotation must match rotation marking.

If pressure differential is not observed or blower* rotation is not correct:

3-Disconnect all remote electrical power supplies.

4-Reverse any two field-installed wires connected to the line side of S48 disconnect or TB13 terminal strip. Do not reverse wires at blower contactor.

5-Make sure the connections are tight.

Discharge and suction pressures should operate at their normal start-up ranges.

*Supply air VFD motors should rotate in the correct direction; verify scroll compressor rotation separately. Contact technical support if the VFD blower is rotating incorrectly.

A-Preliminary Checks

- 1- Make sure that unit is installed in accordance with the installation instructions and applicable codes.
- 2- Inspect all electrical wiring, both field- and factory-installed, for loose connections. Tighten as required.

- 3- Check to ensure that refrigerant lines do not rub against the cabinet or against other refrigerant lines.
- 4- Check voltage at disconnect switch. Voltage must be within range listed on nameplate. If not, consult power company and have voltage condition corrected before starting unit.
- 5- Make sure filters are in place before start-up.

B-Start-Up

- 1- Initiate first and second stage cooling demands according to instructions provided with thermostat.
- 2- **2 Heat / 2 Cool Thermostat** - First-stage thermostat demand will energize compressors 1 and 2. Second-stage thermostat demand will energize compressors 3 and 4. On units with an economizer, when outdoor air is acceptable, a first-stage demand will energize the economizer; a second-stage demand will energize compressors 1 and 2. Refer to the Unit Controller manual provided with each unit for other staging options.
- 3- Each refrigerant circuit is separately charged with R410A refrigerant. See unit rating plate for correct amount of charge. See figure 31 for refrigerant routing on units equipped with a variable air volume supply air blower. See figure 49 for refrigerant routing on units equipped with a hot gas reheat coil.
- 4- Refer to Refrigerant Check and Charge section for proper method to check refrigerant charge.

Manifold gauge sets used with systems charged with R410A refrigerant must be capable of handling the higher system operating pressures. The gauges should be rated for use with pressures of 0-800 on the high side and a low side of 30" vacuum to 250 psi with dampened speed to 500 psi. Gauge hoses must be rated for use at up to 800 psi of pressure with a 4000 psi burst rating.

C-R410A Refrigerant

Units charged with R410A refrigerant operate at much higher pressures than R22. The expansion valve and liquid line drier provided with the unit are approved for use with R410A. Do not replace them with components designed for use with R22.

R410A refrigerant is stored in a pink cylinder.

⚠ IMPORTANT

Mineral oils are not compatible with R410A. If oil must be added, it must be a polyol ester oil.

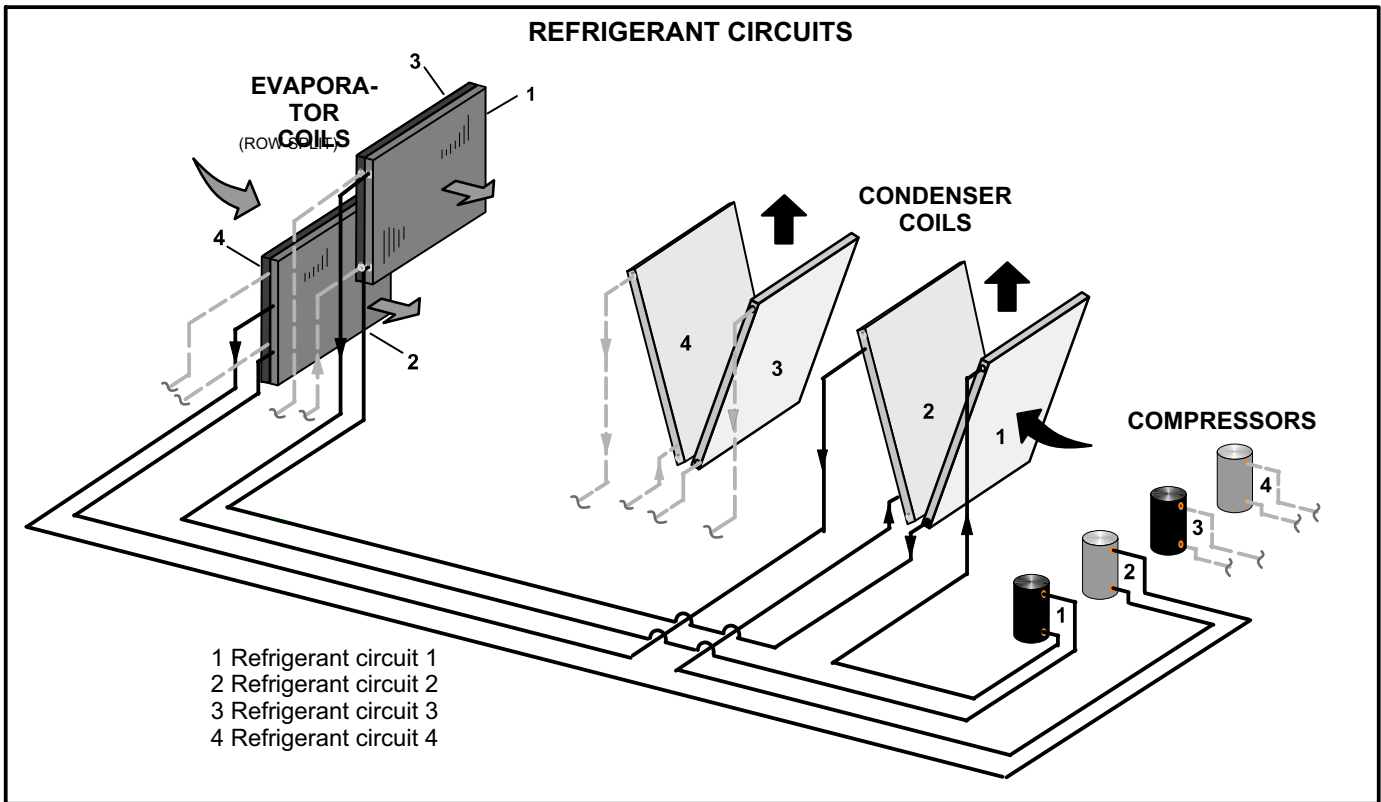

FIGURE 31

D-Refrigerant Charge and Check

WARNING-Do not exceed nameplate charge under any condition.

This unit is factory charged and should require no further adjustment. If the system requires additional refrigerant, reclaim the charge, evacuate the system, and add required nameplate charge.

NOTE - System charging is not recommended below 60°F (15°C). In temperatures below 60°F (15°C), the charge must be weighed into the system.

If weighing facilities are not available, or to check the charge, use the following procedure:

IMPORTANT - Charge unit in cooling mode. Make sure hot gas reheat is not energized.

- 1- Attach gauge manifolds and operate unit in cooling mode at full CFM with economizer disabled until system stabilizes (approximately five minutes). Make sure all outdoor air dampers are closed.
- 2- Check each system separately with all stages operating.
- 3- Use a thermometer to accurately measure the outdoor ambient temperature.
- 4- Apply the outdoor temperature to tables 7 through 12 to determine normal operating pressures. Pressures are listed for sea level applications at 80°F dry bulb and 67°F wet bulb return air.
- 5- Compare the normal operating pressures to the pressures obtained from the gauges. Minor variations in these pressures may be expected due to differences in installations. Significant differences could mean that the system is not properly charged or that a problem exists with some component in the system. **Correct any system problems before proceeding.**
- 6- If discharge pressure is high, remove refrigerant from the system. If discharge pressure is low, add refrigerant to the system.
 - Add or remove charge in increments.
 - Allow the system to stabilize each time refrigerant is added or removed.
- 7- Use the following approach method along with the normal operating pressures to confirm readings.

**TABLE 7
LGH/LCH420S - R410A - VFD**

Outdoor Coil Entering Air Temp	Circuit 1		Circuit 2		Circuit 3		Circuit 4	
	Dis. ±10 psig	Suc. ±5 psig	Dis. ±10 psig	Suc. ±5 psig	Dis. ±10 psig	Suc. ±5 psig	Dis. ±10 psig	Suc. ±5 psig
65°F*	280	112	310	115	310	137	312	141
75°F	330	115	360	118	350	140	350	143
85°F	380	117	410	121	400	142	380	141
95°F	420	121	470	125	450	144	435	143
105°F	495	124	530	128	510	146	490	147
115°F	535	128	590	131	570	148	550	150

**TABLE 8
LGH/LCH420H - R410 - VFD**

Outdoor Coil Entering Air Temp	Circuit 1		Circuit 2		Circuit 3		Circuit 4	
	Dis. ±10 psig	Suc. ±5 psig	Dis. ±10 psig	Suc. ±5 psig	Dis. ±10 psig	Suc. ±5 psig	Dis. ±10 psig	Suc. ±5 psig
65°F*	250	121	280	124	260	140	270	140
75°F	300	124	320	126	305	142	306	142
85°F	330	126	370	127	340	143	350	144
95°F	390	130	420	131	400	146	390	147
105°F	420	131	470	132	450	147	460	148
115°F	470	134	540	134	510	149	520	150

**TABLE 9
LGH/LCH480S - R410A - VFD**

Outdoor Coil Entering Air Temp	Circuit 1		Circuit 2		Circuit 3		Circuit 4	
	Dis. ±10 psig	Suc. ±5 psig	Dis. ±10 psig	Suc. ±5 psig	Dis. ±10 psig	Suc. ±5 psig	Dis. ±10 psig	Suc. ±5 psig
65°F*	282	114	317	116	315	138	316	139
75°F	336	116	361	118	353	139	351	143
85°F	389	119	414	121	403	142	396	145
95°F	429	122	470	124	451	144	441	144
105°F	502	126	529	128	511	147	498	147
115°F	547	130	595	131	576	149	558	150

**TABLE 10
LGH/LCH480H - R410A - VFD**

Outdoor Coil Entering Air Temp	Circuit 1		Circuit 2		Circuit 3		Circuit 4	
	Dis. ±10 psig	Suc. ±5 psig	Dis. ±10 psig	Suc. ±5 psig	Dis. ±10 psig	Suc. ±5 psig	Dis. ±10 psig	Suc. ±5 psig
65°F*	250	121	283	124	267	140	273	140
75°F	301	124	324	126	305	142	306	142
85°F	331	136	371	127	349	143	355	144
95°F	390	130	420	131	398	146	389	147
105°F	428	131	477	132	456	147	459	148
115°F	479	134	537	134	516	149	522	150

**TABLE 11
LGH/LCH540S - R410A - VFD**

Outdoor Coil Entering Air Temp	Circuit 1		Circuit 2		Circuit 3		Circuit 4	
	Dis. ±10 psig	Suc. ±5 psig	Dis. ±10 psig	Suc. ±5 psig	Dis. ±10 psig	Suc. ±5 psig	Dis. ±10 psig	Suc. ±5 psig
65°F*	285	119	324	124	320	138	310	139
75°F	329	121	368	125	355	139	350	140
85°F	391	125	418	128	400	142	400	142
95°F	454	127	476	129	460	144	450	144
105°F	497	130	525	133	515	145	500	147
115°F	554	133	580	136	570	147	555	149

**TABLE 12
LGH/LCH600S - R410A - VFD**

Outdoor Coil Entering Air Temp	Circuit 1		Circuit 2		Circuit 3		Circuit 4	
	Dis. ±10 psig	Suc. ±5 psig	Dis. ±10 psig	Suc. ±5 psig	Dis. ±10 psig	Suc. ±5 psig	Dis. ±10 psig	Suc. ±5 psig
65°F*	251	109	300	111	297	135	295	135
75°F	304	111	342	113	338	136	335	137
85°F	343	114	388	115	382	139	384	140

95°F	398	117	433	117	433	141	424	142
105°F	445	119	489	119	485	142	477	144
115°F	490	122	545	121	537	145	521	146

E-Charge Verification - Approach Method - AHRI TESTING

1-Using the same thermometer, compare liquid temperature to outdoor ambient temperature.

Approach Temperature = Liquid temperature (at condenser outlet) minus ambient temperature.

2-Approach temperature should match values in table 13.

An approach temperature greater than value shown indicates an undercharge. An approach temperature less than value shown indicates an overcharge.

3-The approach method is not valid for grossly over or undercharged systems. Use tables 7 through 12 as a guide for typical operating pressures.

**TABLE 13
APPROACH TEMPERATURES**

420S, 540S	8°F ± 1 (4.4 ± 0.5)
420H, 480H,	6°F ± 1 (3.3 ± 0.5)
480S	9°F ± 1 (5.0 ± 0.5)
600S	7°F ± 1 (3.9 ± 0.5)

F-Compressor Controls

1- High Pressure Switch (S4, S7, S28, S96)

The compressor circuit is protected by a high pressure switch which opens at 640 psig ± 10 psig (4413 kPa ± 70 kPa) and automatically resets at 475 psig ± 20 psig (3275kPa ± 138 kPa).

2- Low Pressure Switch (S87, S88, S97, S98)

The compressor circuit is protected by a low pressure switch. Switch opens at 40 psig ± 5 psig (276 ± 34 kPa) and automatically resets at 90 psig ± 5 psig (621 kPa ± 34 kPa).

3- Crankcase Heater (HR1, HR2, HR5, HR11)

Units have compressors which contain a belly band compressor oil heater which must be on 24 hours before running compressors. Energize by setting thermostat so that there is no cooling demand, to prevent compressor from cycling, and apply power to unit.

4- Low Ambient Pressure Switch (S11, S84, S85, S94)

Switch maintains adequate discharge pressure by de-energizing condenser fan when liquid pressure falls below 240 psig ±10 (1655 kPa±69). Switch closes to energize condenser fan when pressure rises to 450 psig ±10 (3103kPa ± 69).

Condenser fans 1, 2, and 3 are energized when compressor 1 or 2 are operating. Condenser fans 4, 5, and 6 are energized when compressor 3 or 4 are operating. See figure 32.

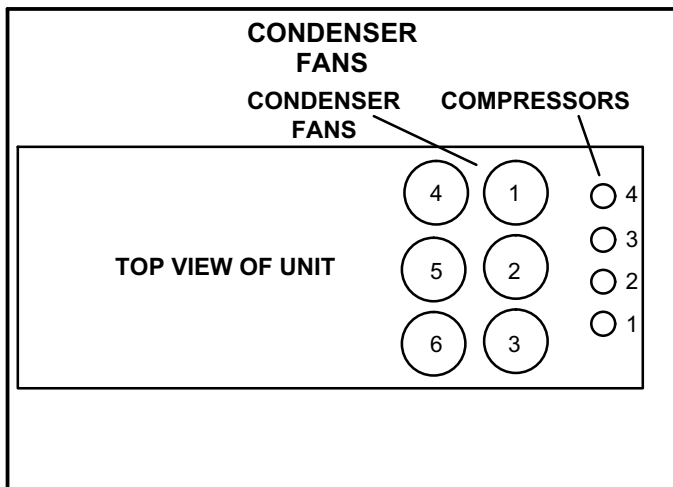

FIGURE 32

The Unit Controller de-energizes condenser fan 2 (K68) and 5 (K152) when outdoor temperature drops below 55°F (13°C).

The Unit Controller de-energizes condenser fan 1 (K10) and 6 (K153) when outdoor temperature drops below 40°F (5°C).

S11 and S84 pressure switches (in refrigerant circuits 1 and 2 respectively) are in parallel; any ONE switch will maintain operation of condenser fan 3 (K149).

S85 and S94 pressure switches (in refrigerant circuits 3 and 4 respectively) are in parallel; any ONE switch will maintain operation of condenser fan 4 (K150).

5- Freezestats (S49, S50, S53, S95)

Switches de-energize compressors when evaporator coil temperature falls below 29°F (-2°C) to prevent evaporator freeze-up. Switches reset when evaporator coil temperature reaches 58°F (15°C).

Gas Heat Start-Up

FOR YOUR SAFETY READ BEFORE LIGHTING

⚠ WARNING



Electric shock hazard. Can cause injury or death. Do not use this unit if any part has been under water. Immediately call a qualified service technician to inspect the unit and to replace any part of the control system and any gas control which has been under water.

⚠ WARNING



Danger of explosion. Can cause injury or death. Do not attempt to light manually. Unit has a direct spark ignition system.

⚠ WARNING



Danger of explosion. Can cause injury or product or property damage. If overheating occurs or if gas supply fails to shut off, shut off the manual gas valve to the appliance before shutting off electrical supply.

⚠ WARNING

SMOKE POTENTIAL

The heat exchanger in this unit could be a source of smoke on initial firing. Take precautions with respect to building occupants and property. Vent initial supply air outside when possible.

BEFORE LIGHTING smell all around the appliance area for gas. Be sure to smell next to the floor because some gas is heavier than air and will settle on the floor.

Use only your hand to push in or turn the gas control knob. Never use tools. If the knob will not push in or turn by hand, do not try to repair it, call a qualified service technician. Force or attempted repair may result in a fire or explosion.

⚠ WARNING



Electric shock hazard. Can cause injury or death. Before attempting to perform any service or maintenance, turn the electrical power to unit OFF at disconnect switch(es). Unit may have multiple power supplies.

This unit is equipped with an automatic spark ignition system. There is no pilot. In case of a safety shutdown, move thermostat switch to **OFF** and return the thermostat switch to **HEAT** to reset ignition control.

A-Placing Unit In Operation

⚠ WARNING



Danger of explosion and fire. Can cause injury or product or property damage. You must follow these instructions exactly.

Gas Valve Operation for Honeywell VR8205Q / VR8305Q and White Rodgers 36H54 (figure 33 and 34)

- 1- Set thermostat to lowest setting.
- 2- Turn off all electrical power to appliance.

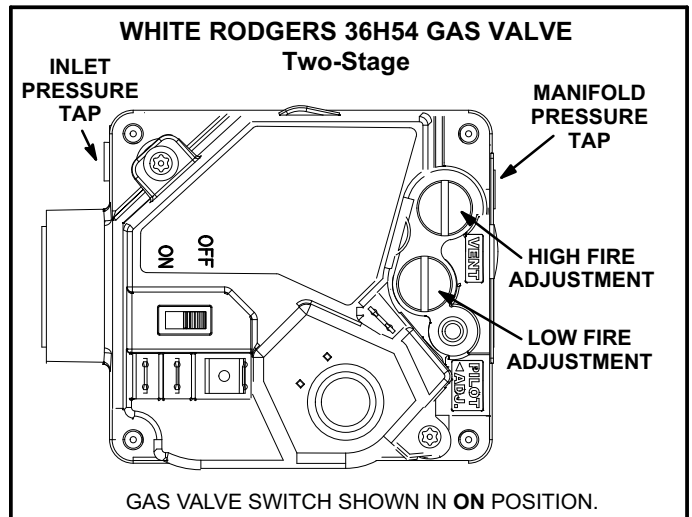

FIGURE 33

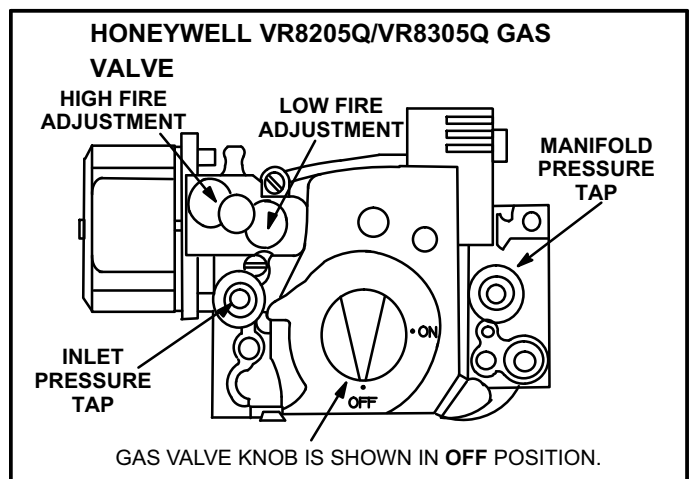





FIGURE 34

- 3- This appliance is equipped with an ignition device which automatically lights the burner. Do **not** try to light the burner by hand.
- 4- Open the heat section access panel.

- 5- Turn gas valve switch to **OFF**. See figure 33. On Honeywell VR8305Q gas valves, turn the knob on the gas valve clockwise  to “**OFF**”. Do not force. See figure 34.
- 6- Wait five (5) minutes to clear out any gas. If you then smell gas, **STOP!** Immediately call your gas supplier from a neighbor's phone. Follow the gas supplier's instructions. If you do not smell gas, go to the next step.
- 7- Turn gas valve switch to **ON**. See figure 33. On Honeywell VR8305Q gas valves, turn the knob on the gas valve counterclockwise  to “**ON**”. Do not force. See figure 34.
- 8- Close or replace the heat section access panel.
- 9- Turn on all electrical power to appliance.
- 10- Set thermostat to desired setting.
- 11- The ignition sequence will start.
- 12- If the appliance does not light the first time (gas line not fully purged), it will attempt up to two more ignitions before locking out.
- 13- If lockout occurs, repeat steps 1 through 10.
- 14- If the appliance will not operate, follow the instructions “Turning Off Gas to Appliance” and call your service technician or gas supplier.

Turning Off Gas to Unit

- 1- If using an electromechanical thermostat, set to the lowest setting.
- 2- Before performing any service, turn off all electrical power to the appliance.
- 3- Open the heat section access panel.
- 4- Turn gas valve switch to **OFF**. On Honeywell VR8305Q gas valves, turn the knob on the gas valve clockwise  to “**OFF**”. Do not force.
- 5- Close or replace the heat section access panel.

Gas Heat Operation and Adjustments

A-Heating Sequence of Operation

- 1- On a heating demand the combustion air inducer starts immediately.
- 2- Combustion air pressure switch proves inducer operation. After a 30-second pre-purge, power is allowed to the ignition control. Switch is factory set and no adjustment is necessary.

- 3- Spark ignitor energizes and gas solenoid valve opens.
- 4- Spark ignites gas, ignition sensor proves the flame and combustion continues.
- 5- If flame is not detected after first ignition trial, ignition control will repeat steps 3 and 4 two more times before locking out the gas valve.
- 6- For troubleshooting purposes, an ignition attempt after lock out may be re-established manually. Move thermostat to “**OFF**” and return thermostat switch to “**HEAT**” position.

B-Limit Controls

Limit controls are factory-set and are not adjustable. On downflow air discharge units, the primary limits (S10 and S99) are located under the collector boxes. On horizontal air discharge units, the primary limit (S10) is located on the blower deck at the rear of the unit.

The secondary limit (S21) is used for both heat sections and is located in the blower compartment.

C-Heating Adjustment

Main burners are factory-set and do not require adjustment.

The following manifold pressures as listed on gas valves:
 Natural Gas Units - Low Fire - 1.6” w.c. (not adjustable)
 Natural Gas Units - High Fire - 3.7” w.c.
 LP Gas Units - Low Fire - 5.5” w.c. (not adjustable)
 LP Gas Units - High Fire - 10.5” w.c.

See Optional Modulating Gas Valve (MGV) section on units equipped with MGVs.

Electric Heat Start-Up (LC Units)

Electric heat is a factory-installed option in LC units in downflow air discharge applications only.

The Unit Controller will operate two stages of electric heat in thermostat control mode. The Unit Controller will operate up to four stages of electric heat in zone sensor or discharge air control mode. Refer to the Unit Controller manual provided with unit. Refer to electric heat wiring diagram on unit for sequence of operation.

Economizer Start-Up

The economizer, when configured, controls:

- Damper position, which determines how much outdoor air is used to meet free cooling or indoor air quality requirements, and
- Optional power exhaust fans.

On a cooling demand, outdoor air is used for free cooling instead of first-stage compressor(s) when outdoor air is suitable.

1.1. Enabling Economizer and Settings

To enable the economizer, if installed, go to **SETUP > INSTALL** and go through the wizard. When reaching **Configuration ID 1**, position **2** will need to be set to the applicable type of economizer. Valid types are:

- **M** = Motorized Outdoor Air Damper Only

- **T** = Economizer - Temperature (*Note: Used for both set point and offset temperature control.*)
- **G** = Economizer - Global
- **S** = Economizer - Single Enthalpy
- **D** = Economizer - Dual Enthalpy

Table 14 to 18 show the options depending on economizer type set above. These settings are also available through the main menu at **SETUP > TEST & BALANCE > DAMPER**.

Use the **SETUP > TEST & BALANCE > DAMPER** menu to check damper position. Visually inspect the damper position and follow prompts to determine proper function. Make sure zone boxes are open and respond to prompts to operate the blower. Follow prompts to set minimum damper position for high and low blower speeds.

TABLE 14
MENU INTERFACE (LEVEL 1 - SETTINGS) - M (MOTORIZED OUTDOOR AIR DAMPER ONLY)

Level 2	Level 3	Level 4	Level 5	USE THE ADJUST AND SET VALUES ARROWS TO SCROLL UP OR DOWN FOR SELECTION OPTIONS.	
RTU OPTION	DAMPER	MIN DAMPER POSITION BLOWER ON HIGH = X.X %			
		MIN DAMPER POSITION BLOWER ON LOW = X.X %			
		DEMAND CONTROL VENT DAMPER START OPEN = XXXX.X PPM			
		DEMAND CONTROL VENT DAMPER FULL OPEN = XXXX.X PPM			
		DEMAND CONTROL VENT DAMPER MAX OPENING = XXX.X%			
		FRESH AIR HEATING ENABLE FAH = YES OR NO	FRESH AIR HEATING FAH SETPOINT = XX F		
		FRESH AIR COOLING ENABLE AFC = YES OR NO	FRESH AIR COOLING AFC SETPOINT = XX F		

TABLE 15
MENU INTERFACE (LEVEL 1 - SETTINGS) - T (TEMPERATURE ECONOMIZER)

Level 2	Level 3	Level 4	Level 5	USE THE ADJUST AND SET VALUES ARROWS TO SCROLL UP OR DOWN FOR SELECTION OPTIONS.	
RTU OPTION	DAMPER	ECONOMIZER TEMP ECON TYPE = TEMPERATURE OFFSET OR TEMPERATURE SETPT ECONOMIZER OAT SETPOINT = XX.X F			
		FREE COOLING SUPPLY AIR SETPOINT = XX F			
		MIN DAMPER POSITION BLOWER ON HIGH = X.X %			
		MIN DAMPER POSITION BLOWER ON LOW = X.X %			
		DEMAND CONTROL VENT DAMPER START OPEN = XXXX.X PPM			
		DEMAND CONTROL VENT DAMPER FULL OPEN = XXXX.X PPM			
		DEMAND CONTROL VENT DAMPER MAX OPENING = XXX.X%			
		FRESH AIR HEATING ENABLE FAH = YES OR NO	FRESH AIR HEATING FAH SETPOINT = XX F		
		FRESH AIR COOLING ENABLE AFC = YES OR NO	FRESH AIR COOLING AFC SETPOINT = XX F		

TABLE 16
MENU INTERFACE (LEVEL 1 - SETTINGS) - G (GLOBAL ECONOMIZER)

Level 2	Level 3	Level 4	Level 5	USE THE ADJUST AND SET VALUES ARROWS TO SCROLL UP OR DOWN FOR SELECTION OPTIONS.	
RTU OPTION	DAMPER	FREE COOLING SUPPLY AIR SETPOINT = XX F			
		MIN DAMPER POSITION BLOWER ON HIGH = X.X %			
		MIN DAMPER POSITION BLOWER ON LOW = X.X %			
		DEMAND CONTROL VENT DAMPER START OPEN = XXXX.X PPM			
		DEMAND CONTROL VENT DAMPER FULL OPEN = XXXX.X PPM			
		DEMAND CONTROL VENT DAMPER MAX OPENING = XXX.X%			
		FRESH AIR HEATING ENABLE FAH = YES OR NO	FRESH AIR HEATING FAH SETPOINT = XX F		
		FRESH AIR COOLING ENABLE AFC = YES OR NO	FRESH AIR COOLING AFC SETPOINT = XX F		

TABLE 17
MENU INTERFACE (LEVEL 1 - SETTINGS) - S (SINGLE ENTHALPY)

Level 2	Level 3	Level 4	USE THE ADJUST AND SET VALUES ARROWS TO SCROLL UP OR DOWN FOR SELECTION OPTIONS.		
RTU OPTION	DAMPER	ECONOMIZER ENTHALPY SETPOINT = XX.X MA	ENTHALPY SET POINT 73°F 70°F 67°F 63°F	MA SETTING 12.0 13.6 15.5 17.6	
		FREE COOLING SUPPLY AIR SETPOINT = XX.X F	CLIMATE ZONE 1, 3, 5, 11-16 2, 4, 10 6, 8, 9 7	SINGLE SENSIBLE 75.0°F 73.0°F 71.0°F 69.0°F	
		MIN DAMPER POSITION BLOWER ON HIGH = X.X %			
		MIN DAMPER POSITION BLOWER ON LOW = X.X %			
		DEMAND CONTROL VENT DAMPER START OPEN = XXXX.X PPM			
		DEMAND CONTROL VENT DAMPER FULL OPEN = XXXX.X PPM			
		DEMAND CONTROL VENT DAMPER MAX OPENING = XXX.X%			
		FRESH AIR HEATING ENABLE FAH = YES OR NO	FRESH AIR HEATING FAH SETPOINT = XX F		
		FRESH AIR COOLING ENABLE AFC = YES OR NO	FRESH AIR COOLING AFC SETPOINT = XX F		

TABLE 18
MENU INTERFACE (LEVEL 1 - SETTINGS) - D (DUAL ENTHALPY)

Level 2	Level 3	Level 4	USE THE ADJUST AND SET VALUES ARROWS TO SCROLL UP OR DOWN FOR SELECTION OPTIONS.		
RTU OPTION	DAMPER	ECONOMIZER ENTHALPY OFFSET = X.XX MA	TEMP OFFSET* °F 2 3.5 5.3 7	RELATIVE HUMIDITY OFFSET %** 6 12 18 24	MA SETTING 1.0 2.0 3.0 4.0
		FREE COOLING SUPPLY AIR SETPOINT = XX F	CLIMATE ZONE 1, 3, 5, 11-16 2, 4, 10 6, 8, 9 7	SINGLE SENSIBLE 75°F 73°F 71°F 69°F	
		MIN DAMPER POSITION BLOWER ON HIGH = X.X %			
		MIN DAMPER POSITION BLOWER ON LOW = X.X %			
		DEMAND CONTROL VENT DAMPER START OPEN = XXXX.X PPM			
		DEMAND CONTROL VENT DAMPER FULL OPEN = XXXX.X PPM			
		DEMAND CONTROL VENT DAMPER MAX OPENING = XXX.X%			
		FRESH AIR HEATING ENABLE FAH = YES OR NO	FRESH AIR HEATING FAH SETPOINT = XX F		
		FRESH AIR COOLING ENABLE AFC = YES OR NO	FRESH AIR COOLING AFC SETPOINT = XX F		

1.2. Damper Operation During Free Cooling

These are operating profile options for the economizer damper (Parameter 164 - ECONOMIZER PROFILE) during free cooling when any compressor is on and can be selected as follows:

Option 0: Damper continues to modulate while compressors are on, but the effect of mechanical cooling may force the damper closed to its minimum position. After compressor starts, the free cooling set point is lowered to fixed temperature setting of 45°F.

Option 1: Damper opens to its max-open position (Parameter 131 - FREE CL MAX DAMPER) when any compressors start.

NOTE - When using Option 1 and after the compressor is stopped, the M3 shall resume damper modulation.

Option 2: Is as follows:

- Holds-off compressor on Y2 call until damper has modulated to maximum position (Parameter 131 - FREE CL MAX DAMPER) for three minutes.
- After three minutes, the compressor starts and the free cooling set point is lowered to 45°F. Damper is not locked at maximum open while compressor is on, but modulates to maintain 45°F discharge air temperature.
- When Y2 is satisfied, compressor goes off and free cooling set point is restored to 55°F (Parameter 159 - FREE COOL SUPPLY SP).

Option 3: Same as Option 2, but with a ten-minute delay instead of a three-minute delay.

1.3. Free Cooling Compressor Lockout Mode and Low Ambient Set Point

Go to **SETTINGS > RTU OPTION > EDIT PARAMETER = 285 (FRCL COMP LCKOUT MD)**. Default value is 2. Range is 0 to 2.

0 = Disable Compressor Lockout

1 = Lockout Compressor if outdoor air is suitable regardless of outdoor air temperature.

2 = Lockout Compressor if outdoor air temperature is below Parameter 108 setting and Outdoor Air is Suitable (Default).

Go to **SETTINGS > RTU OPTION > EDIT PARAMETER = 108 (FREE LO AMB LCKT SP)**. Default value is 55.0°F. Range is 45.0 to 80.0°F.

1.4. Outdoor Air Suitable for Free Cooling

The M3 Unit Controller displays the outdoor air suitability information on the status screen.

The appropriate sensors are provided when the economizer is factory-configured. See figure 35 and 36 for factory-installed sensor locations. When the economizer is field-installed and configured, the single or dual enthalpy modes require additional field-provided sensor(s).

California Title 24 Compliance

For *California Title 24* compliance, adjust the free cooling setpoint based on:

-The climate zone where the unit is installed. See table 19.

-The setpoint requirement published by the California Energy Commission. See *Section 140.4 - Prescriptive Requirements for Space Conditioning Systems of the 2013 Building Energy Efficiency Standards*.

Note - Values in the referenced standard will supersede values listed in table 19.

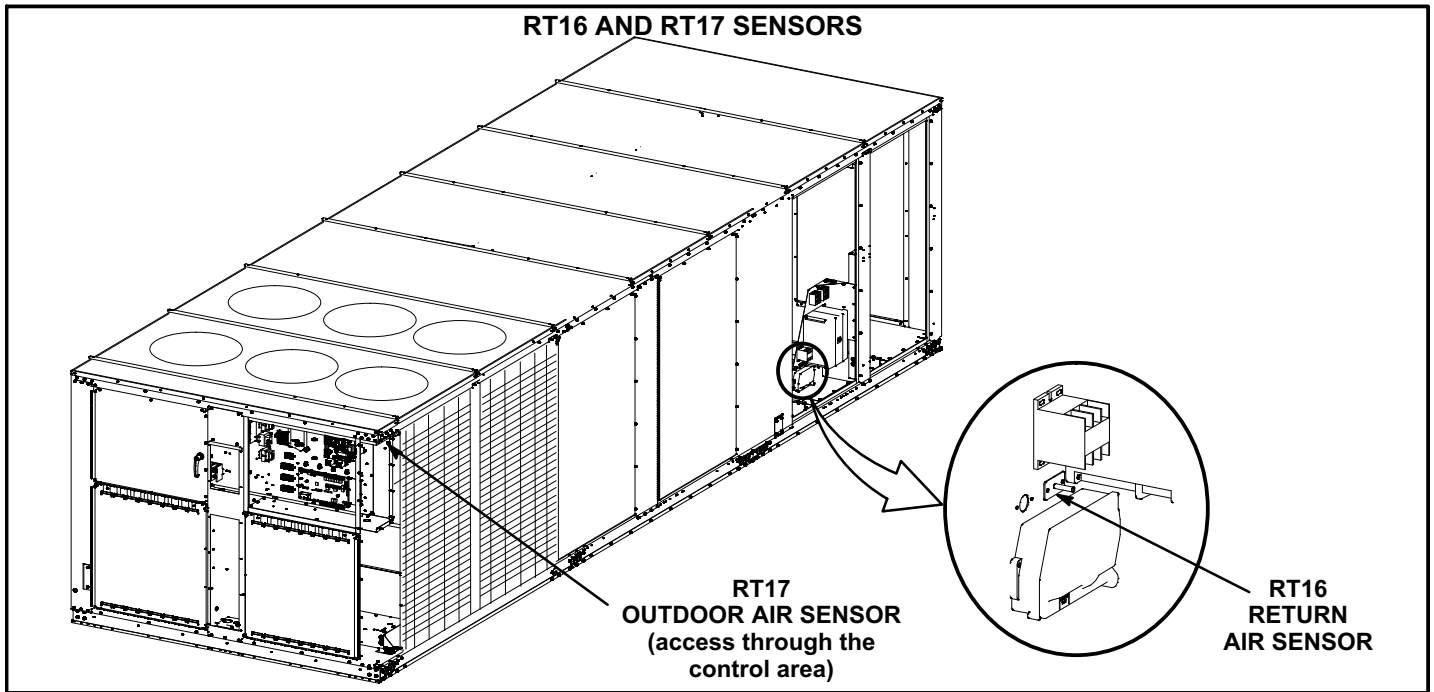

FIGURE 35

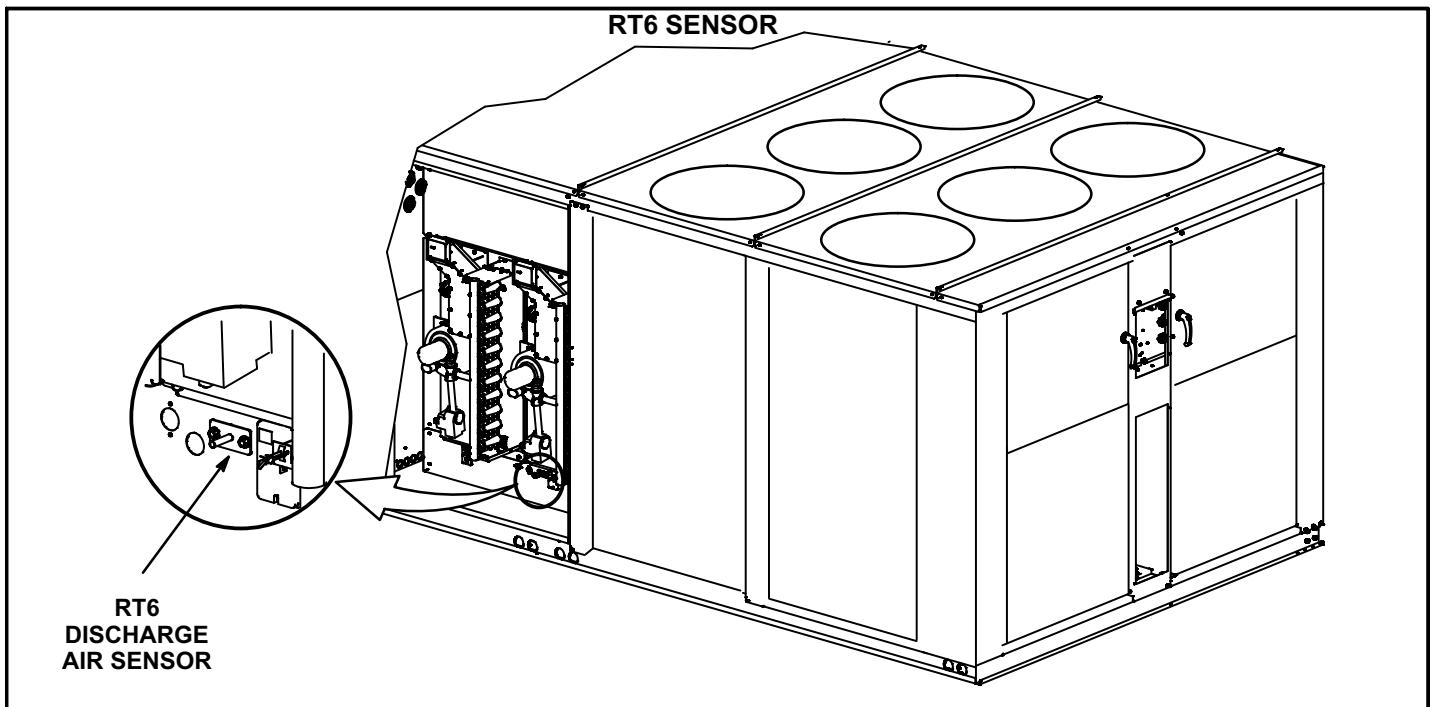

FIGURE 36

**TABLE 19
TITLE 24 COMPLIANCE FREE COOLING SETPOINT**

Climate Zone	Setpoint (Single Sensible)	Setpoint (Differential Sensible)
1, 3, 5, 11-16	75°F	0°F
2, 4, 10	73°F	2°F
6, 8, 9	71°F	4°F
7	69°F	6°F

1.5. Enthalpy Set Point

This setting pertains to the single enthalpy free cooling mode only. The M3 Unit Controller will enable free cooling when outdoor air enthalpy (A7) is less than the enthalpy set point (Parameter 162 - ECON FREECL ENTH SP). Figure 37 shows the approximate enthalpy sensor output at various temperatures and percentage of relative humidity.

ENTHALPY SENSOR OUTPUT CURRENT HONEYWELL C7400

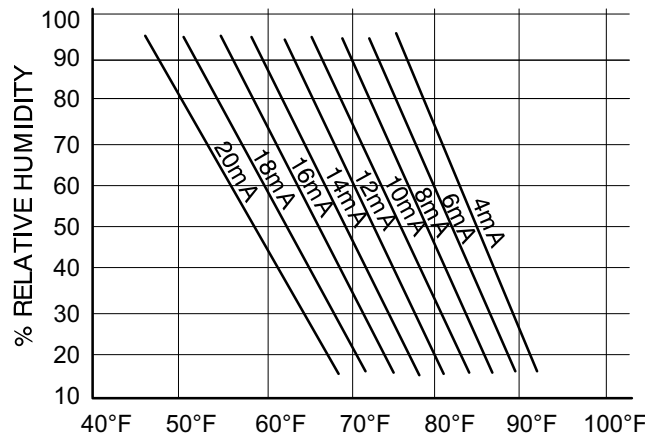

FIGURE 37

1.6. Free Cooling Damper Maximum Position

Damper Maximum position for free cooling is by default set to 100%. To modify this settings, use the following path:

SETTINGS > RTU OPTION > EDIT PARAMETER - 131 (FREE CL MAX DAMPER)

1.7. Minimum Damper Position

Use the following menu path to modify the minimum damper positions for both high and low operations.

SETUP > TEST & BALANCE > DAMPER > MIN DAMPER POSITION BLOWER ON HIGH = .%

SETUP > TEST & BALANCE > DAMPER > MIN DAMPER POSITION BLOWER ON LOW = .%

Units Equipped With An Energy Recovery Wheel

The economizer minimum damper position must be adjusted to allow for the air resistance of the ERW.

- 1- Determine the required outdoor air CFM.
- 2- Apply the CFM to table 20 to determine the target static pressure drop across the ERW.
- 3- Measure the static pressure drop across the ERW. See figure 38.
- 4- Adjust the minimum % open damper position (see previous section).
- 5- Read the static pressure drop across the ERW and adjust the minimum % open damper position as needed to reach the target pressure drop.

For example, a unit with an outdoor air flow of 6500 CFM would require an ERW pressure drop of 0.90”w.c.

1.8. Motorized Outdoor Air Damper

Set damper position according to “Minimum Damper Position” section 1.7. For normal operation, make sure the motorized outdoor air damper is set correctly in **Configuration ID 1**, position **2** needs to be set to **M**. The damper will open to the specified position during the occupied time period and close during the unoccupied time period.

NOTE - When equipped with Motorized Outdoor damper Air Damper, Prodigy 2.0 provides only Demand Control Ventilation. Free Cooling/Economizer function is not available.

**TABLE 20
ERW PRESSURE DROP**

Outdoor Flow - cfm	Static Pressure - in. w.c.
3250	0.45
3500	0.48
3750	0.52
4000	0.55
4250	0.59
4500	0.62
4750	0.66
5000	0.69
5250	0.73
5500	0.76
5750	0.80
6000	0.83
6250	0.87
6500	0.90
6750	0.94
7000	0.97
7250	1.01
7500	1.04
7750	1.08
8000	1.11
8250	1.15
8500	1.18
8750	1.22
9000	1.25

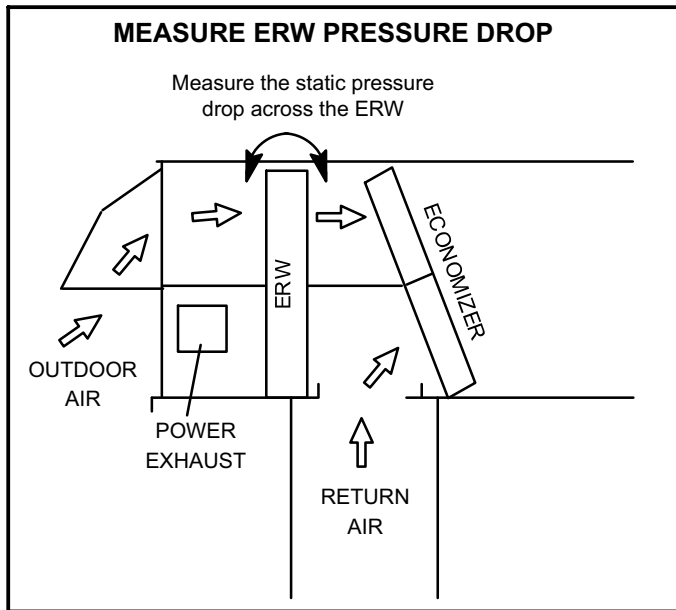

FIGURE 38

1.9. Economizer Checkout

The following checkout procedures are completed with unit energized. Confirm proper operation of the heartbeat LED. Step 1 will determine whether the economizer is allowing full damper travel. Use step 2 when the damper does not respond to step 1.

Steps 3, 4, 5, and 6 checkout the operating modes; checkout only the mode that applies to the unit being worked on.

CAUTION

Power exhaust fans will be functional. To prevent operation of power exhaust fans, disconnect power to unit and then PED jack/plug P/J18.:

Step 1. ECONOMIZER OUTPUT VOLTAGE

The M3 Unit Controller monitors P262 (DPOS) and operates as reference in Section *Damper Diagnostics in the Prodigy 2.0 (M3 Unit Controller) Application Guide (Advance Features)*.

- A Go to **SERVICE > TEST > DAMPER>POSITION > DAMPER POSITION ACTUAL: 0.0%** The motor will slowly modulate to the closed position.
- B Change DAMPER POSITION ACTUAL to 100.0%.The motor will slowly modulate to the fully opened position.
- C If the motor does not respond, go to step 2. If the motor does respond properly, go to the appropriate mode of operation checkout.

Step 2. OUTPUT VOLTAGE CHECK

- A Go to **SERVICE > TEST > DAMPER > POSITION > DAMPER POSITION ACTUAL: 0.0%**
- B Adjust the DAMPER POSITION ACTUAL: to 0.0% position.

- C Measure the voltage on P262 between pin 3 (VOT damper control) and pin 2 (GND) **using pin 1 as common**. Voltage should read approximately 2 VDC.

- D Adjust the DAMPER POSITION ACTUAL: to 100.0% position.

NOTE - Allow approximately 90 seconds for actuator to react.

- E Measure the voltage between P262 between pin 3 (VOT damper control) and pin 2 (GND) **using pin 1 as common**. Voltage should read approximately **10 volts DC**. If not, check wiring and trouble shoot system.

Step 3. SINGLE ENTHALPY OPERATION (ODE)

In the single enthalpy mode, dampers open for free cooling when the outdoor enthalpy is less than the enthalpy set point (Parameter 162 - ECON FREECL ENTH SP); dampers will try to modulate discharge air temperature (RT6) to (Parameter 159 - FREE COOL SUPPLY SP) which has a default setting of 55.0°F (13°C).

- A Go to **SETUP > INSTALL >** press **SAVE** until you get to the **Configuration ID 1**, position **2** needs to be set to **S** for Economizer - Single Enthalpy and press **SAVE**.

- B To simulate low outdoor enthalpy. Disconnect A7 outdoor enthalpy sensor jack/plugs J/P104. Connect a 750 ohm resistor across plug J104-1 and J104-2. J104 is located in the filter access area.

- C Check all connections and wiring between J104 and the control.

Step 4. DUAL ENTHALPY MODE OF OPERATION

In dual enthalpy mode mode, dampers open for free cooling when the outdoor air enthalpy is lower than the return air enthalpy by difference value of (Parameter 163 - ECN FRCL ENTH OFFST); dampers will modulate discharge air temperature (RT6) to (Parameter 159 - FREE COOL SUPPLY SP) which has a default setting of 55.0°F (13°C).

- A Go to **SETUP > INSTALL >** press **SAVE** until you get to the **Configuration ID 1** position **2** needs to be set to **D** for Economizer - Dual Enthalpy and press **SAVE** if performing an economizer field-install.

- B Use two resistors to simulate outdoor air enthalpy suitable.

- ⓧ Disconnect A62 return air enthalpy sensor jack/plug J/P105. Place a 1500 ohm resistor between J105-1 and J105-3. J/P105 is located in the filter access area.

- ⓧ Disconnect A7 outdoor enthalpy sensor jack/plugs J/P104. Connect a 750 ohm resistor across J104-1 and J104-2.

Step 5. ALL TEMPERATURE MODES OF OPERATION

In the Economizer – Temperature mode, the damper opens for free cooling when the outdoor air temperature is:

- Less than return air temperature by at least a difference of (Parameter 161 - ECON FRCL TMP OFFST) if Temperature Offset mode is selected
- Less than (Parameter 160 - ECON FREECL TEMP SP)

In all modes, dampers will try to modulate discharge air temperature (RT6) to (Parameter 159 - FREE COOL SUPPLY SP) which has a default setting of 55.0°F (13°C).

Refer to the “Displaying Sensor Inputs” section to read return air (RT16) and outdoor air (RT17) temperatures. If outdoor air is not cooler than return air, simulate a colder outdoor air temperature with a resistor. Select a resistor value that corresponds to a temperature (see table 21):

- Locate RT17 sensor in unit. Disconnect 1/4" quick connect terminals on wires leading from sensor.
- Jumper RT17 wires leading back to control with the appropriate resistor.
- Check all connections and wiring between RT17 and the M3 Unit Controller, and between RT16 and the M3 Unit Controller.

Temp. °F (°C)	Size Resistor	Temp. °F (°C)	Size Resistor	Temp. °F (°C)	Size Resistor	Temp. °F (°C)	Size Resistor
30 (-1)	34,566	50 (10)	19,904	70 (21)	11,884	90 (32)	7,332
40 (4)	26,106	60 (16)	15,313	80 (27)	9,298	100 (38)	5,826

Step 6. GLOBAL MODULATING (GLO) MODE OF OPERATION

In the GLO (modulating) mode, dampers modulate open for free cooling when the global input is energized; dampers will try to modulate discharge air temperature (RT6) to (Parameter 159 - FREE COOL SUPPLY SP) which has a default setting of 55.0°F (13°C).

NOTE - The global input turns on the blower.

- Set **global** mode using the **Configuration ID 1**, position **2**, and set to character **G**.
- Connect a jumper between A55_P297-1 (24VAC) and A55_P297-9 (global). The blower will be energized and the damper will slowly open if discharge air temperature (RT6) is greater than (Parameter 159 - FREE COOL SUPPLY SP) which has a default setting of 55.0°F (13°C).
- Disconnect 24VAC to A55_P297-9. The blower will turn off and the damper will close.
- If the damper does not actuate check all connections and wiring between P262A and B.

Step 7. ENTHALPY SENSOR OPERATION (A7 and A62)

- Connect a direct current ammeter as shown in figure 39 to measure current output of A7 or A62.

NOTE - If Enthalpy Sensors are configured, current sensor reading by M3 controller can be verified on User interface:

- The reading will be between 4 and 20 ma. depending on outdoor temperature and humidity. Refer to figure 37 to approximate reading.

Go to **DATA > IN/OUTPUTS > SENSORS > LOCAL** (scroll down to **IE: x.x mA** and **OE: x.x mA**)

- If the meter reads zero, check sensor wiring harness for continuity and/or check polarity of sensor wiring.

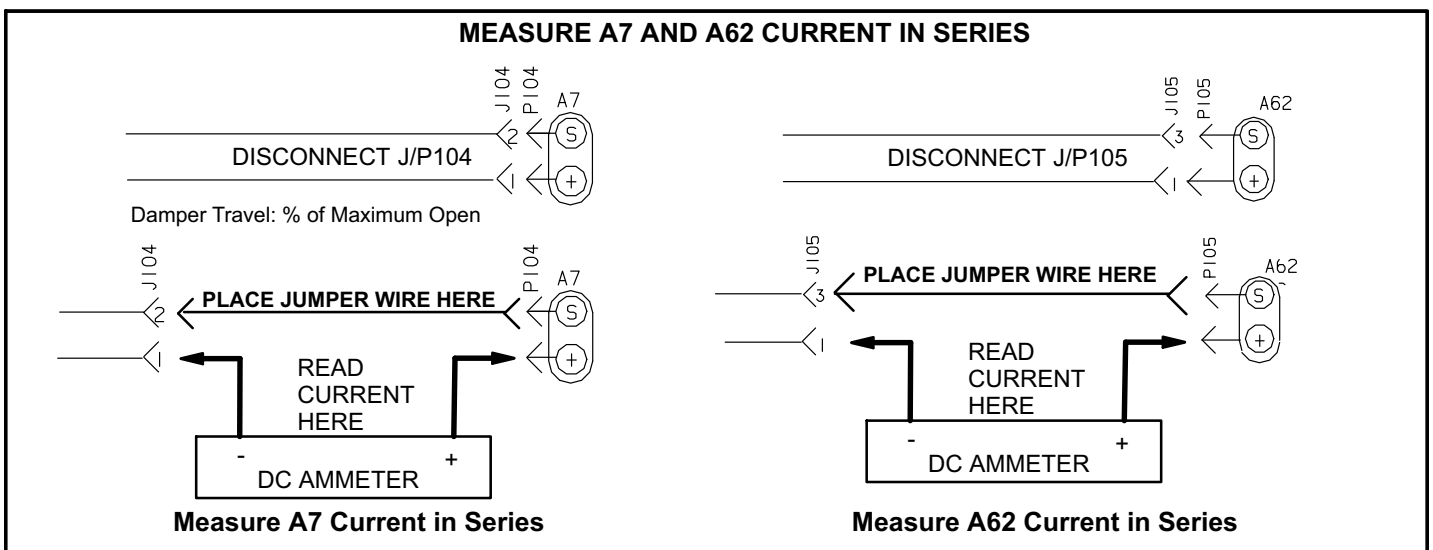

FIGURE 39

1.10. Demand Control Ventilation

1.10.1. General

A field-provided and installed indoor air quality (IAQ) sensor can be used with the modulating economizer or OADM to control carbon dioxide levels in the conditioned space. The carbon dioxide level in a space is an indicator of the number of people occupying a room. As the carbon dioxide level rises (indicating the occupancy of a room has increased), dampers modulate open - regardless of outdoor air suitability. Likewise, as the carbon dioxide level falls (indicating the occupancy has decreased), dampers modulate further closed.

Standard economizer installations have a minimum fresh air ventilation requirement based on maximum room occupancy. With standard economizer use, the amount of air required for maximum room occupancy is heated or cooled with each heating or cooling cycle. IAQ installations use the maximum amount of required ventilation air only with maximum room occupancy; less outdoor air needs to be heated or cooled when fewer people are in the conditioned space.

If the economizer is operating in the free cooling mode and the indoor air quality control requires the damper to open further, the indoor air quality demand will override the free cooling demand.

The IAQ function is not energized during the unoccupied or night time period.

NOTE - The IAQ sensor may also be used with systems containing a motorized outdoor air damper.

1.10.2. Default Operation

The M3 Unit Controller has a 0-10VDC indoor air quality input for a standard 0 - 2000ppm carbon dioxide sensor. The economizer starts opening at a carbon dioxide level of 500 ppm (default) (start open set point) and reaches full open at a carbon dioxide level of 1000ppm (default) (full open set point).

The damper opens to a default position of 100% (see Parameter 117). Determine damper travel position using the following formula.

$$\% \text{ Damper Travel} = \frac{\text{carbon dioxide ppm} - \text{Start Open ppm}}{5}$$

5

Example: At a carbon dioxide level of 750ppm, the damper will be approximately 50% open:

$$\% \text{ Damper Travel} = \frac{750-500}{5} = 50\%$$

5

Use the menu interface to read carbon dioxide ppm. **DATA > IN/OUTPUTS > SENSORS > CO2**. Figure 40 shows default or proportional operation.

1.10.3. Maximum and Minimum Demand Control Ventilation Damper Settings

Maximum position is set using the following menu path:

Go to **SETUP > TEST & BALANCE > DAMPER > DAMPER MAX OPENING = .%**

Use the following menu path to modified the minimum damper positions for both high and low blower operations.

Go to **SETUP > TEST & BALANCE > DAMPER > MIN DAMPER POSITION BLOWER ON HIGH = .%**

Go to **SETUP > TEST & BALANCE > DAMPER > MIN DAMPER POSITION BLOWER ON LOW = .%**

1.10.4. Parameter Adjustments

Default indoor air quality economizer operation is based on common or average applications. Adjustments may be made to the indoor air quality parameters to alter operation or meet required specifications. Use the user interface to change Parameter 117 through 119. Go to **SETTINGS > RTU OPTIONS > EDIT PARAMETER**

Select a demand control ventilation mode with Parameter 134. Modes 3 and 4 will bring on the unit blower when demand control ventilation calls for maximum damper open, and returns to auto-blower when demand control ventilation damper returns to 0. The other modes only operate when the unit blower is on, but will not bring it on themselves.

Some applications require a different carbon dioxide set point range than default settings. Damper "start open" (Parameter 118 and "full open" (Parameter 119) carbon dioxide set points may be adjusted from 0 to 2000 ppm. Use the following formula to determine damper travel.

NOTE - When changing carbon dioxide set point range, "start open" set point should be less than "full-open" set point.

$$\% \text{ Damper Travel} = \frac{\text{carbon dioxide ppm} - \text{Start Open ppm}}{\text{Full Open} - \text{Start Open}} \times \text{Max Open (Parameter 117)}$$

Example: An application requires the dampers open at 800 CO₂ ppm and reach full open at 1200. If the carbon dioxide level in the space reads 1000 ppm, calculate the damper percent open as follows.

$$\% \text{ Damper Travel} = \frac{1000 - 800}{1200 - 800} \text{ or } \frac{200}{400} \text{ or } .5 = 0.5 \times 100 = 50\%$$

DEFAULT DEMAND CONTROL VENTILATION (DCV) OPERATION

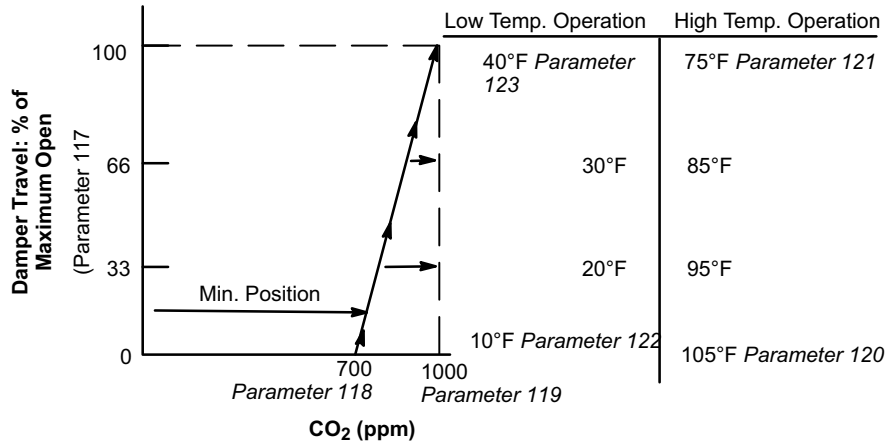

FIGURE 40

**TABLE 22
DEMAND CONTROL VENTILATION PARAMETERS**

Control Parameter			Control Value			Units	Description
No	Screen Name	Parameter Short Description	Min.	Default	Max.		
117	DCV MAX DAMPER OPEN	Demand Control Ventilation Maximum Damper Open	0	100	100	%	Maximum allowed demand control ventilation damper open position.
118	DCV DAMP START OPEN	Demand Control Ventilation Damper Start Open	0	700	2000	PPM	<input type="checkbox"/> Damper "start open" CO ₂ set point for Demand Control Ventilation. <input type="checkbox"/> Level where fresh air damper begins to open.
119	DCV DAMP FULL OPEN	Demand Control Ventilation Maximum Damper Full Open Set Point	0	1200	2000	PPM	<input type="checkbox"/> Damper "full open" CO ₂ set point for Demand Control Ventilation. <input type="checkbox"/> Level where fresh air damper is opened to maximum.
120	DCV HI TMP OV FL CL	Demand Control Ventilation Outdoor Air Control Hi Temperature Override Full Closed	-31.0	105.0	132.0	°F	High outdoor air temp. where fresh air damper is closed to minimum position.
121	DCV HI TMP OV ST CL	Demand Control Ventilation Outdoor Air Control Hi Temperature Override Start Closing	-31.0	75.0	132.0	°F	High outdoor air temperature where fresh air damper begins to close.
122	DCV LO TMP OV FL CL	Demand Control Ventilation Outdoor Air Control Low Temperature Override Full Closed	-31.0	10.0	132.0	°F	Low outdoor air temperature where fresh air damper is closed to minimum position

**TABLE 22
DEMAND CONTROL VENTILATION PARAMETERS**

Control Parameter			Control Value			Units	Description
No	Screen Name	Parameter Short Description	Min.	Default	Max.		
123	DCV LO TMP OV ST CL	Demand Control Ventilation Outdoor Air Control Low Temperature Override Start Closing	-31.0	40.0	132.0	°F	Low outdoor air temp. where fresh air damper begins to close.
134	IAQ INPUT MODE	Indoor Air Quality Input Mode	0	1	6	Option	<p>IAQ input source and mode (0-3 operate only when blower is on).</p> <p>0- Demand Control Ventilation System Indoor Air Quality. Either P298-3 or network indoor air quality.</p> <p>1- Demand Control Ventilation System Indoor Air Quality. Either P298-3 or network Indoor Air Quality with no outdoor air temperature limits.</p> <p>2- Outdoor Air Control Sensor A24 (A133_P194-6) (TB22-6).</p> <p>3- Outdoor Air Control Sensor A24 (A133_P194-6) (TB22-6) with no outdoor air temperature limits.</p> <p>4- Demand Control Ventilation System Indoor Air Quality. Either P298-3 or network Indoor Air Quality with blower on/auto operation.</p> <p>5- Demand Control Ventilation System Indoor Air Quality. Either P298-3 or network Indoor Air Quality with blower on/auto operation with no outdoor air temperature limits.</p>

1.10.4.1. Set Point Control Option

Set point control mode is commonly used in areas with high occupancy and frequent change out such as classrooms or conference rooms.

In applications requiring this on/off damper response to carbon dioxide levels, set the start open (Parameter 118 - DCV DAMP START OPEN) set point higher than the full open (Parameter 119 - DCV DAMP FULL OPEN) set point. The dampers will drive to fully-open position immediately. Figure 41 shows the set point control option.

Change Parameters 122 and 123 to set the minimum outdoor temperature limits. Change Parameters 120 and 121 to set the maximum temperature limits.

⚠ IMPORTANT

Mixed air temperatures less than 45°F (7°C) on units with an aluminized heat exchanger or less than 30°F (-1°C) on stainless steel heat exchangers will void the manufacturer's warranty.

1.10.4.2. Determining Indoor Air Quality Inputs

Go to **DATA> IN/OUTPUTS > SENSORS** menu selection from the M3 Unit Controller menu display.

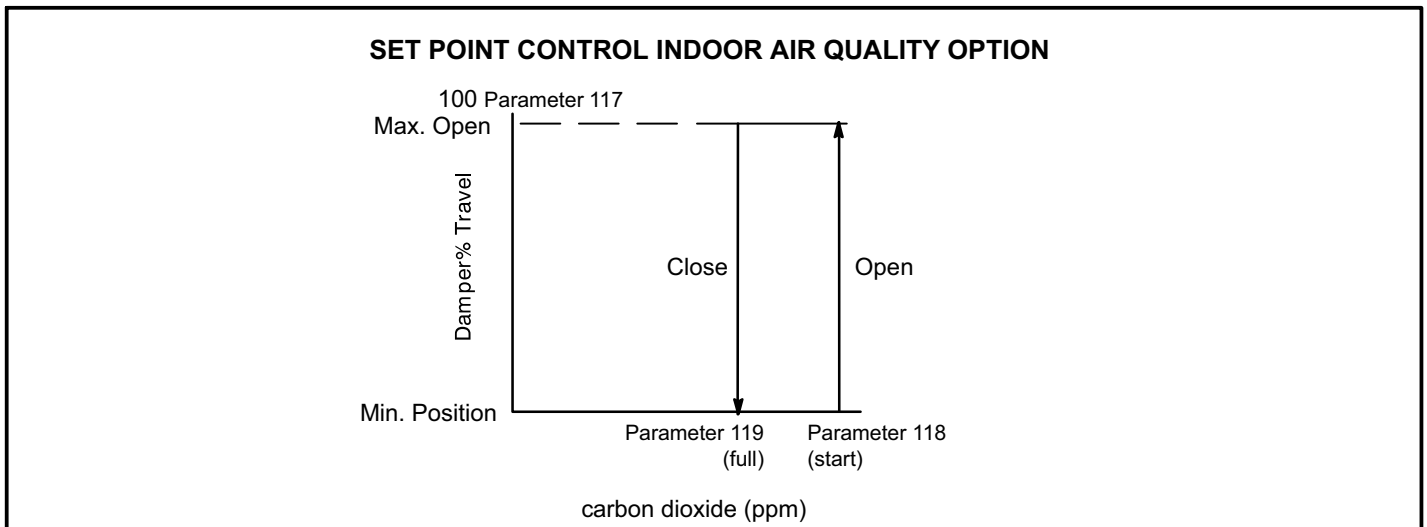

FIGURE 41

Optional Power Exhaust

General

Unit may contain one or two power exhaust fans or blowers. Exhaust blowers are shown in figure 42. Exhaust fans are located in the same place and discharge air in the same direction.

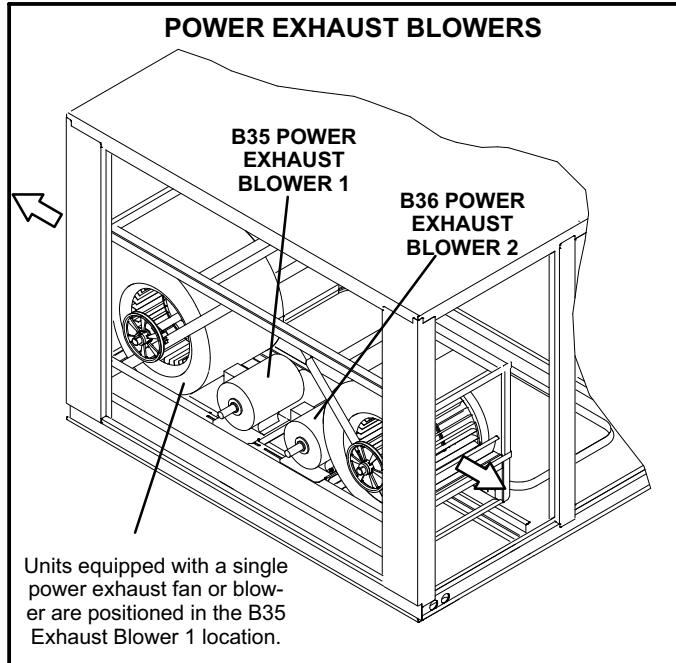

FIGURE 42

Power exhaust equipped with two fans or blowers is operated in two stages. Power exhaust blowers may be equipped with a variable frequency drive (VFD) A137 to vary exhaust air CFM.

The Unit Controller will use damper position or building static pressure to initiate power exhaust.

Optional Power Exhaust Variable Frequency Drive

Power Exhaust VFD (A137) will increase exhaust air CFM when building pressure is higher than setpoint and decrease the volume when building pressure is lower than setpoint. The default setpoint is 0.1" w.c.

Power exhaust VFD is available with one or two blowers; only one VFD is required. The power exhaust VFD is located in the return air compartment on the back side of the unit. See figure 43.

Power Exhaust Control Options

Damper Position

The Unit Controller will initiate stage 1 power exhaust when economizer or outdoor air damper travel reaches 50%. The Unit Controller will initiate stage 2 power exhaust when economizer or outdoor air damper travel reaches 75%. Refer to the Unit Controller manual parameters 217 and 221 to adjust the default setting.

POWER EXHAUST VARIABLE FREQUENCY DRIVE

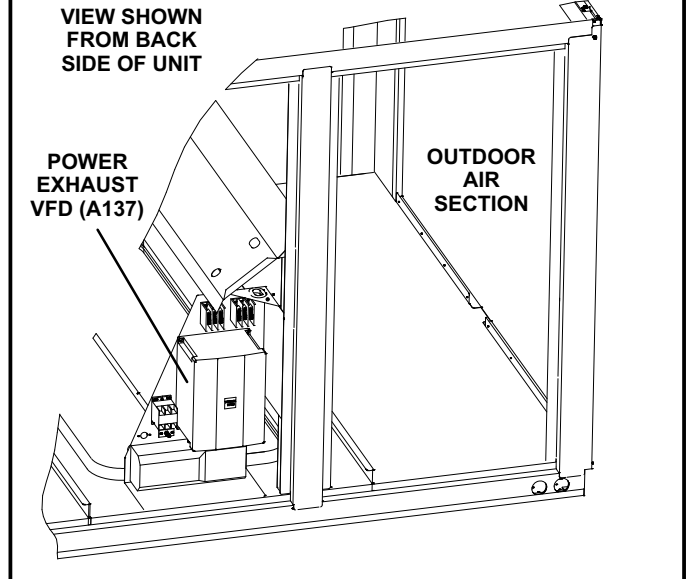

FIGURE 43

Pressure Switches (S37 and S39)

Field-installed switches are used to sense the static pressure difference between outdoor air and building air. Power exhaust equipped with one fan or blower uses one switch (S37). Power exhaust equipped with two fans uses both switches.

Stage 1 power exhaust will be energized above 0.1" w.c. (default) building static pressure. Stage 2 power exhaust will be energized if building static pressure rises above 0.2" w.c. (default). Use parameter 217 to adjust stage 1 setpoint and parameter 221 to adjust stage 2 setpoint.

Install the switches according to manufacturer's instructions. Use a field-provided Outdoor Kit on the outdoor (reference) air tubing to prevent pressure fluctuations due to wind gusts.

Pressure Transducer (A34)

The optional factory-installed pressure transducer is used to sense the static pressure difference between outdoor air and building air. The transducer is located in the return air section of unit near the supply air VFD (A96). See figure 22. Only one pressure transducer is needed regardless of number of exhaust blowers.

Stage 1 power exhaust constant air volume will be energized above 0.1" w.c. (default) building static pressure. Stage 2 power exhaust constant air volume will be energized if building static pressure rises above 0.2" w.c. (default). Use parameter 217 to adjust stage 1 setpoint and parameter 221 to adjust stage 2 setpoint. Power exhaust equipped with a VFD will vary the CFM output to maintain a building static pressure of 0.1" w.c.

Complete transducer installation as follows:

1- Connect field-provided 1/4" tubing to the (+) port on the transducer. Route tubing through unit return air opening to a return air grille in the duct work.

2- Locate the outdoor air kit shipped in a box in the unit filter section. Install outdoor air kit on the top of the unit in location shown in figure 44. Use manufacturer's instructions.

Note - Outdoor kit reduces fluctuations in reference reading due to wind gusts.

3- Locate the tubing provided with the outdoor air kit. Route the tubing from the outdoor kit through the hole under the intake hood to A34 as shown in figure 44. Connect tubing to the (-) port on the transducer. Coil and secure excess tubing - do not cut.

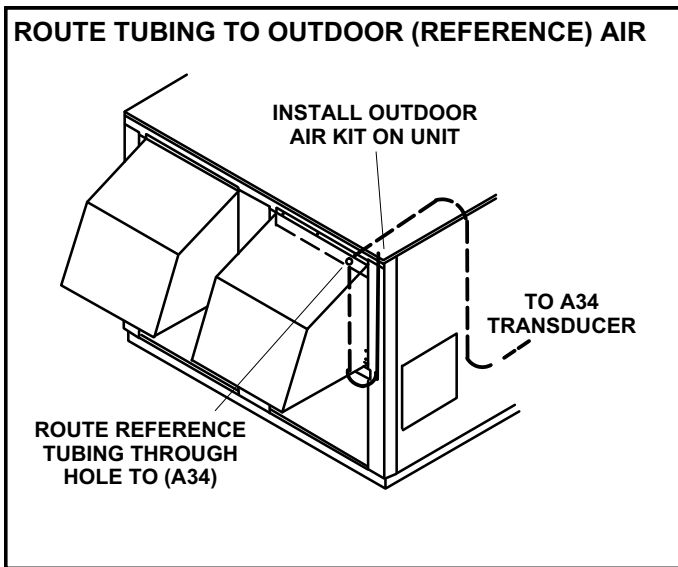

FIGURE 44

Power Exhaust VFD By-Pass Plug (Optional)

The power exhaust VFD may be by-passed using jack/plug connections. Locate J/P211 connectors in control box area under the relays. Disconnect J211 from P211 and connect J215 to P211. See figure 45. Exhaust blower will operate at maximum speed.

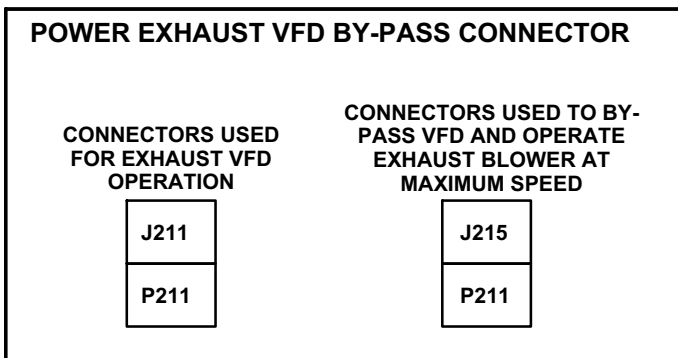

FIGURE 45

Optional Outdoor Air Dampers

Unit may contain optional outdoor air dampers which provide fresh outdoor air. Dampers are either motorized or manually set. Motorized dampers are controlled by the Unit Controller. Manual dampers are adjusted and remain in the same position. Set the damper minimum position in the same manner as the economizer.

Optional Barometric Relief Dampers

Unit may contain optional barometric relief dampers in the unit return air compartment to relieve excess building pressure. Remove shipping strap and replace screws before operation. No adjustments are necessary.

Optional Outdoor Air / Barometric Relief Hoods

Hoods are shipped in the filter section.

1-Remove the shipping covers over the outdoor air openings.

2-Assemble hoods as shown in figure 46.

3-Secure hoods to unit as shown in figure 47. Outdoor air filters are factory-installed in unit.

4-When installing outdoor air hoods, secure hinged panel on screen to unit . See figure 48. Install two screws to hold screen in place.

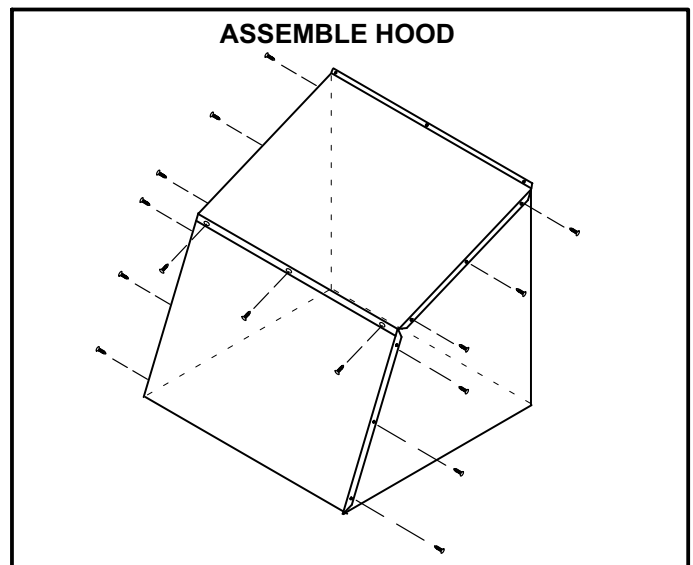

FIGURE 46

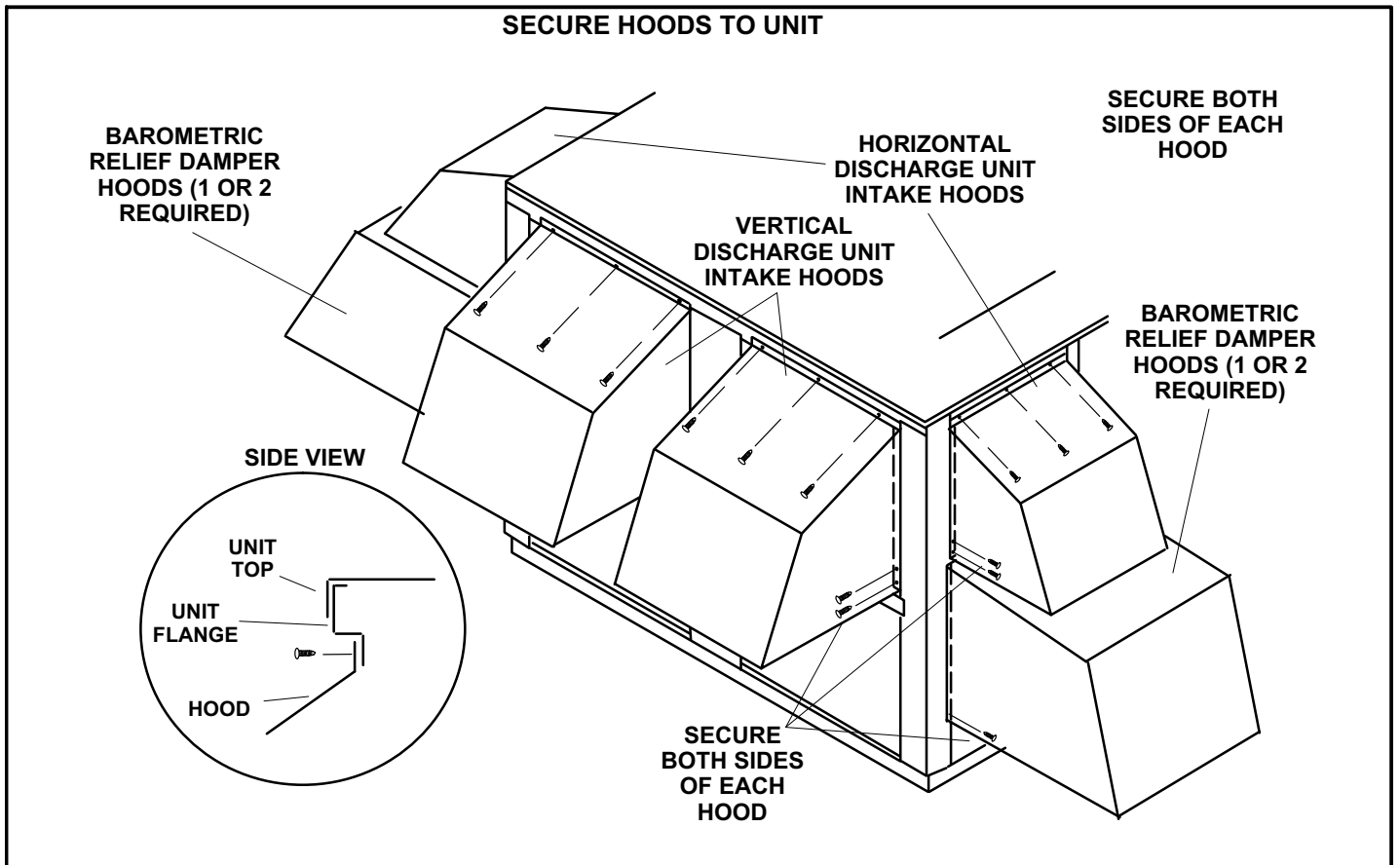

FIGURE 47

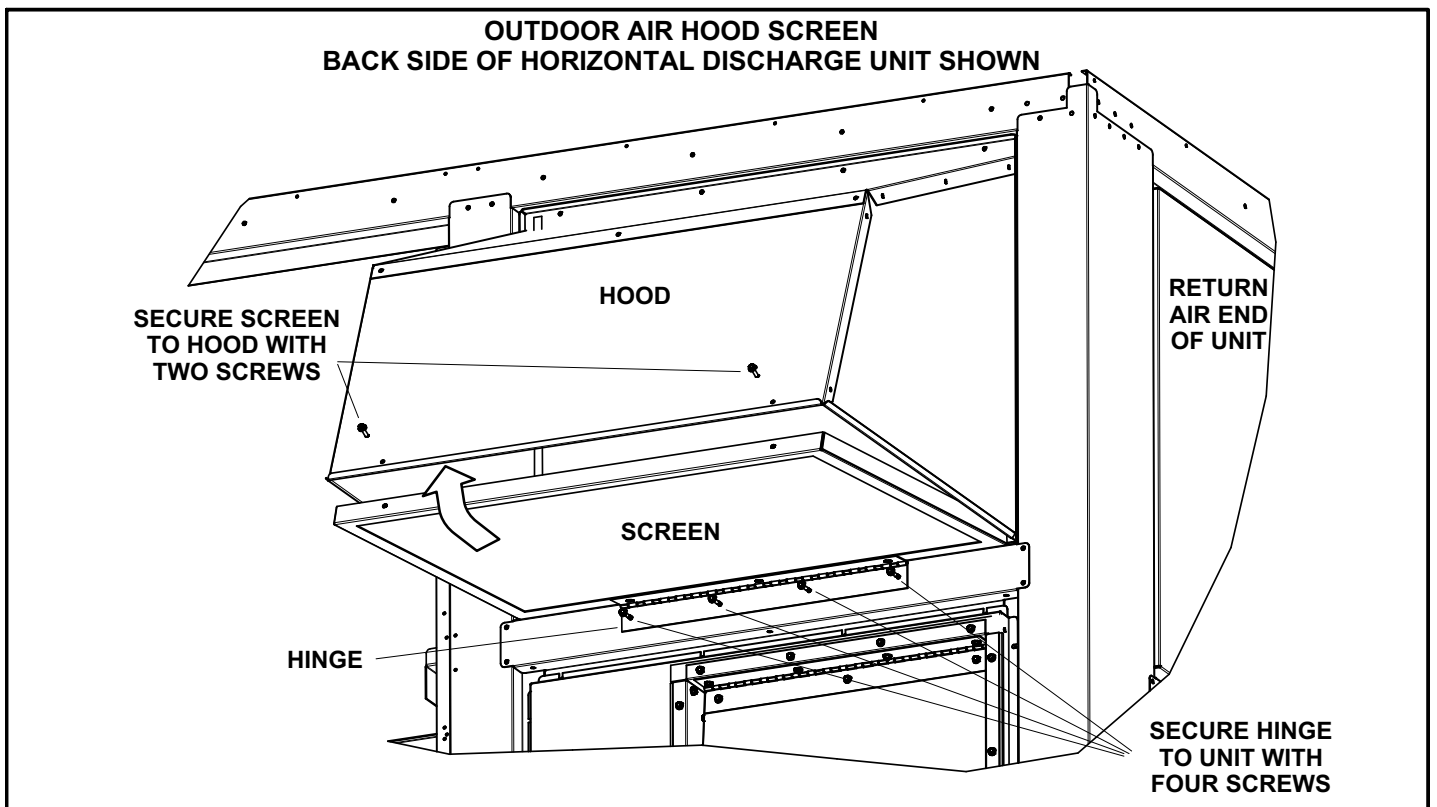

FIGURE 48

Optional Hot Gas Reheat

General

Hot gas reheat units provide a dehumidifying mode of operation. These units contain a reheat coil adjacent to and downstream of the evaporator coil. Reheat coil solenoid valves, L14 and L30, route hot discharge gas from the compressor to the reheat coil. Return air pulled across the evaporator coil is cooled and dehumidified; the reheat coil adds heat to supply air.

See 49 for reheat refrigerant routing.

L14 and L30 Reheat Coil Solenoid Valves

When Unit Controller indicates room conditions require dehumidification, L14 and L30 reheat valves are energized and refrigerant is routed to the reheat coil.

Reheat Setpoint

Reheat is factory-set to energize when indoor relative humidity rises above 60% (default). The reheat setpoint can be adjusted by changing parameter 106 (SETUP MENU). A setting of 100% will operate reheat from an energy management system digital output. The reheat setpoint can also be adjusted using an optional Network Control Panel (NCP).

Reheat will terminate when the indoor relative humidity falls 3% (57% default) or the digital output de-energizes. The reheat deadband can be adjusted 1-10% RH by changing parameter 107.

A91 Humidity Sensor

Relative humidity should correspond to the sensor (A91) output voltage listed in table 23. For example: if indoor air relative humidity is $80\% \pm 3\%$, the humidity sensor output should read 8.00VDC.

Check the sensor output annually for accuracy. Keep the air intake openings on the sensor clean and free of obstructions and debris.

TABLE 23

Relative Humidity (%RH $\pm 3\%$)	Sensor Output (VDC)
20	2.00
30	3.00
40	4.00
50	5.00
60	6.00
70	7.00
80	8.00
90	9.00

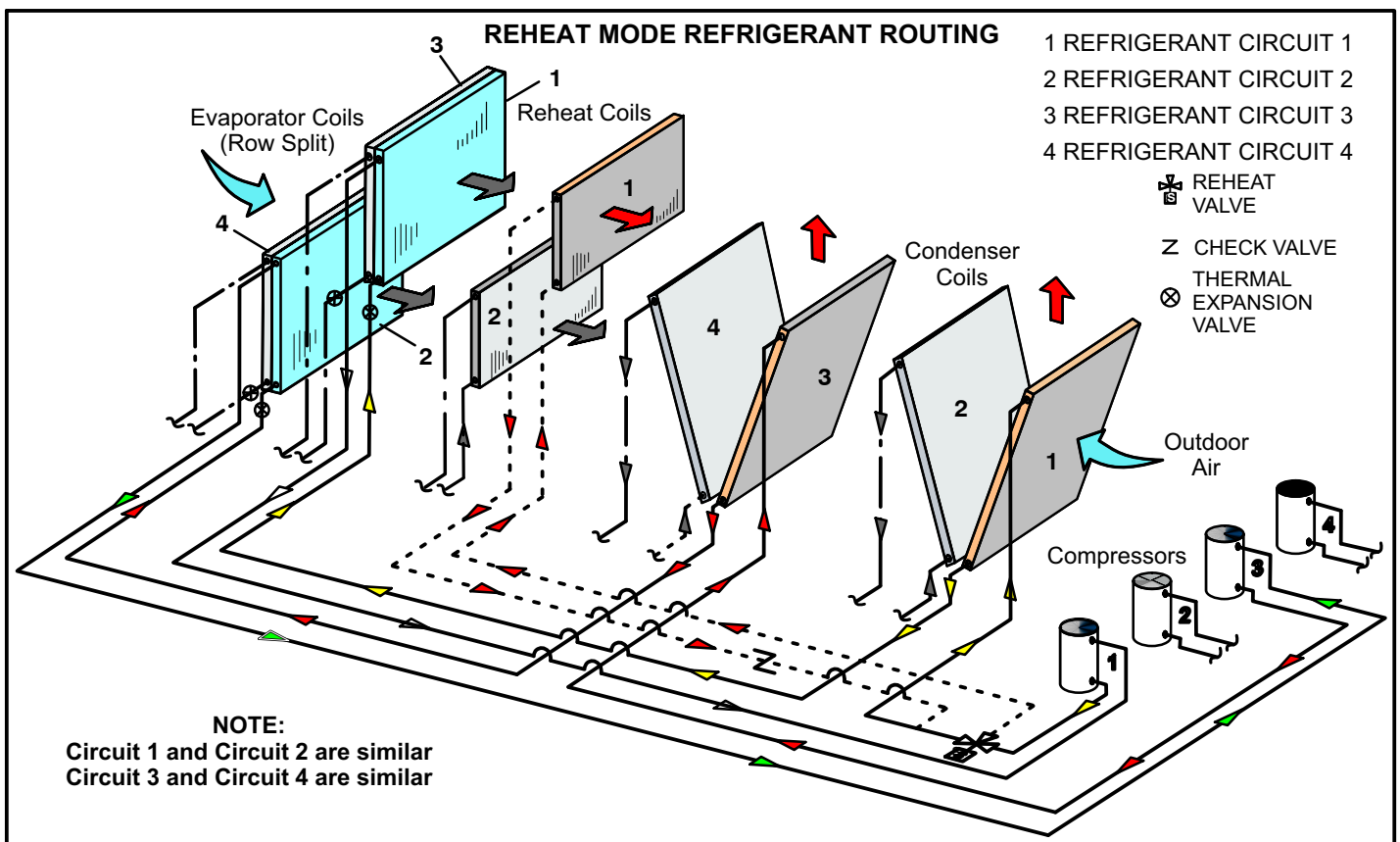

FIGURE 49

Check-Out

Test hot gas reheat operation using the following procedure.

- 1- Make sure reheat is wired as shown in wiring section.
- 2-Make sure unit is in local thermostat mode.
- 3-Select Unit Controller *Service - Test*.

The blower, compressor 1, and compressor 2 (reheat) should be operating. Reheat mode will appear on the Unit Controller display.

Reheat Operation

The following conditions must be met before reheat will be energized:

- 1- Blower must be operating.
- 2- System must be in occupied mode.
- 3- System must NOT be operating in heating mode.
- 4- One cooling demand is required if the unit has been in heating mode, the Unit Controller has been reset, or at initial unit start-up.

IMPORTANT - Free cooling does not operate during reheat. Free cooling will operate as shown in the Unit Controller manual.

Reheat will operate as shown in table 24.

Units are shipped from the factory to provide two stages of cooling.

Three stages of cooling is available in zone sensor mode. Three stages of cooling is also available by installing a transfer relay and a three-stage thermostat; set parameter 111 to 3.

Four stages of cooling is available in zone sensor mode on units with four compressors.

Compressors are not de-energized when unit operation changes from cooling to reheat or from reheat to cooling. Instead, L14 and L30 reheat valves are energized (reheat) or de-energized (cooling).

NOTE - Another thermostat staging option is available which allows both compressors to be energized during free cooling. See Unit Controller manual for details.

**TABLE 24
REHEAT OPERATION**

Two-Stage Thermostat - Default	
T'stat and Humidity Demands	Operation
	Compressors
Reheat Only	Compressor 1 & 2 Reheat
Reheat & Y1	Compressor 1 & 2 Reheat and Compressor 3 & 4 Cooling ¹
Reheat &Y1 & Y2	Compressor 1, 2, 3 & 4 Cooling ³
Three-Stage Thermostat (Transfer relay required)	
T'stat and Humidity Demands	Operation
	Compressors
Reheat Only	Compressor 1 & 2 Reheat
Reheat & Y1	Compressor 1 & 2 Reheat and Compressor 3 Cooling ¹
Reheat Y1 & Y2	Compressor 1 & 2 Reheat and Compressor 3, & 4 Cooling ³
Reheat Y1 & Y2 & Y3	Compressor 1, 2, 3, & 4 Cooling ⁴
Four-Stage Zone Sensor Mode	
Cooling* and Humidity** Demands	Operation
	Compressors
Reheat Only	Compressor 1 & 2 Reheat
Reheat & Y1	Compressor 1 & 2 Reheat and Compressor 3 Cooling ¹
Reheat & Y1 & Y2	Compressor 1 & 2 Reheat and Compressor 3 & 4 Cooling ²
Reheat & Y1 & Y2 & Y3	Compressor 1, 2, & 3 Cooling ³
Reheat & Y1 & Y2 & Y3 & Y4	Compressor 1, 2, 3, & 4 Cooling ⁵

*Cooling stage is initiated when zone temperature is higher than the cooling setpoint plus the appropriate stage differential (ECTO 6.10, 6.12, 6.13, 6.14).

**Reheat demand is initiated when relative humidity is higher than relative humidity setpoint.

- 1 If there is no reheat demand and outdoor air is suitable, free cooling will operate.
- 2 If there is no reheat demand and outdoor air is suitable, free cooling and compressor 1 will operate.
- 3 If there is no reheat demand and outdoor air is suitable, free cooling and compressor 1 and 2 will operate.
- 4 If there is no reheat demand and outdoor air is suitable, free cooling, compressor 1, 2, and 3 will operate.
- 5 If there is no reheat demand and outdoor air is suitable, free cooling, compressor 1, 2, 3, and 4 will operate.

The following conditions must be met before reheat will be energized:

- 1- Blower must be operating.
- 2- System must be in occupied mode.
- 3- System must NOT be operating in heating mode.
- 4- One cooling demand is required if the unit has been in heating mode, the Unit Controller has been reset, or at initial unit start-up.

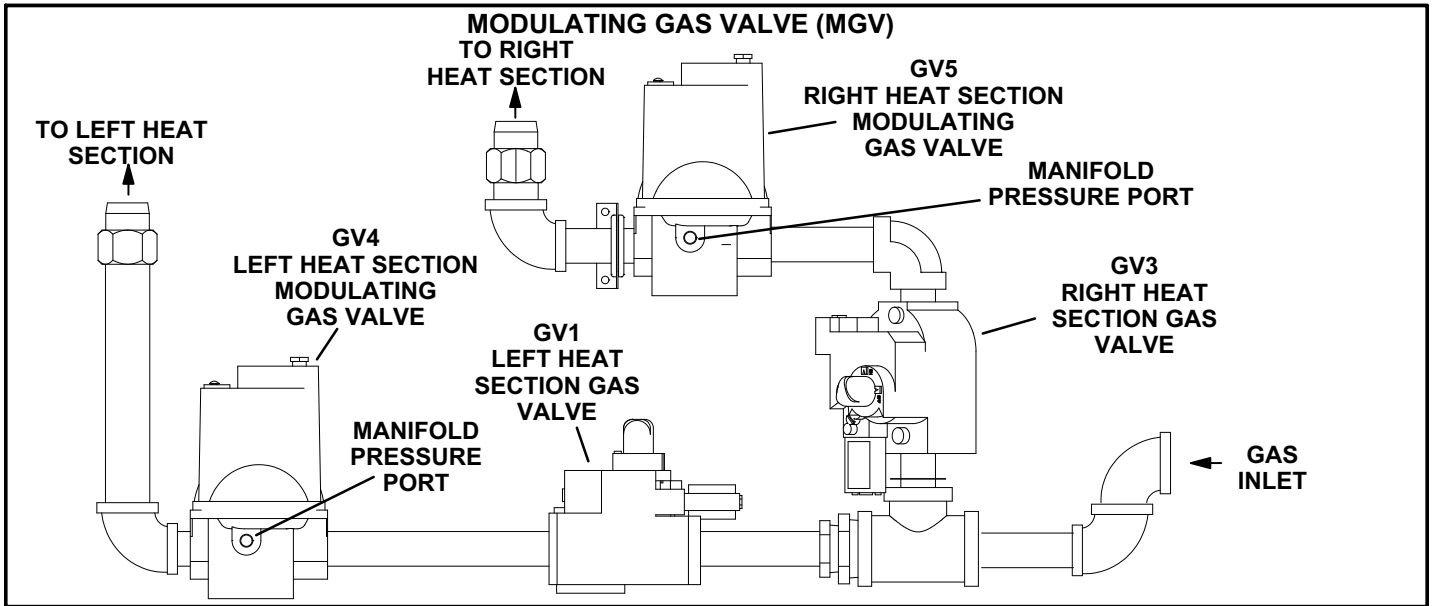

FIGURE 50

Optional Modulating Gas Valve (MGV)

Units equipped with optional modulating gas valves (MGV) contain two modulating gas valves in addition to two standard gas valves. See figure 50.

Operation

The Unit Controller will control modulating gas valves to maintain 110°F (default) discharge air during the heating cycle. The left heat section will operate when 25-50% of nameplate heat is needed. Both heat sections will operate when 50-100% of the nameplate heat is needed.

The normally open MGV will allow full heating capacity should the MGV fail.

Start-Up

- 1- Operate the unit in heating mode according to the Heating Start-Up section in this manual.
- 2- After the unit has operated for 5 minutes, use the Unit Controller *Service - Test* menu to run high capacity. The unit will operate at maximum heating input.
- 3- Measure the manifold pressure at the gas valves. Manifold pressures should be:

- GV1 & GV3:
Natural - 4.0" w.c. LP - 10.8" w.c.
- GV4 & GV5:
Natural - 3.7" w.c. LP - 10.5" w.c.

- 4- Use the options in the Unit Controller *Service Test* menu to run low capacity. The unit will operate at minimum heating input.

- 5- Measure the manifold pressure at the gas valves. Manifold pressures should be:

- GV1 & GV3:
Natural - 4.0" w.c. LP - 10.8" w.c.
- GV4 & GV5:
Natural - 0.9" w.c. LP - 2.6" w.c.

Unit Controller Output

The Unit Controller 0-10VDC output to the MGVs increases to modulate valves further closed during a reduced heating demand. The Unit Controller 0-10VDC output to the MGVs decreases to modulate valves further open during a higher heating demand.

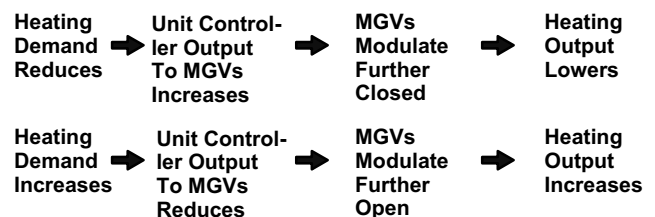

Optional Hot Gas Bypass (HGB)

Hot gas bypass is a factory-installed option only. The HGB valve routes refrigerant from the discharge line to the suction line to keep the evaporator coil from icing when supply air volume is low. The HGB valve will start to open

when the suction pressure drops below 105 psig (R410A). The de-superheating TXV routes cooler gas from the liquid line to the suction line. This prevents high refrigerant temperatures in the compressor. See figure 51 for components and figure 52 for refrigerant routing.

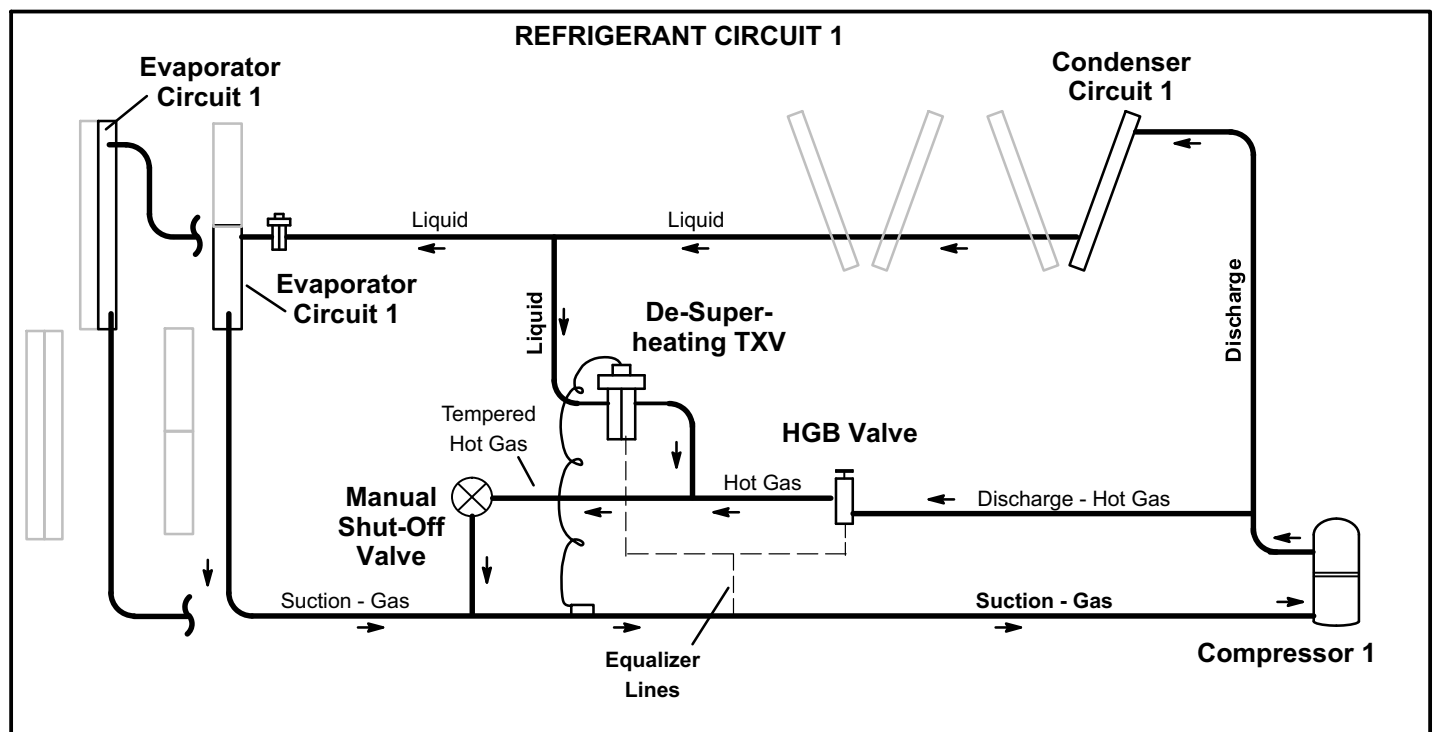
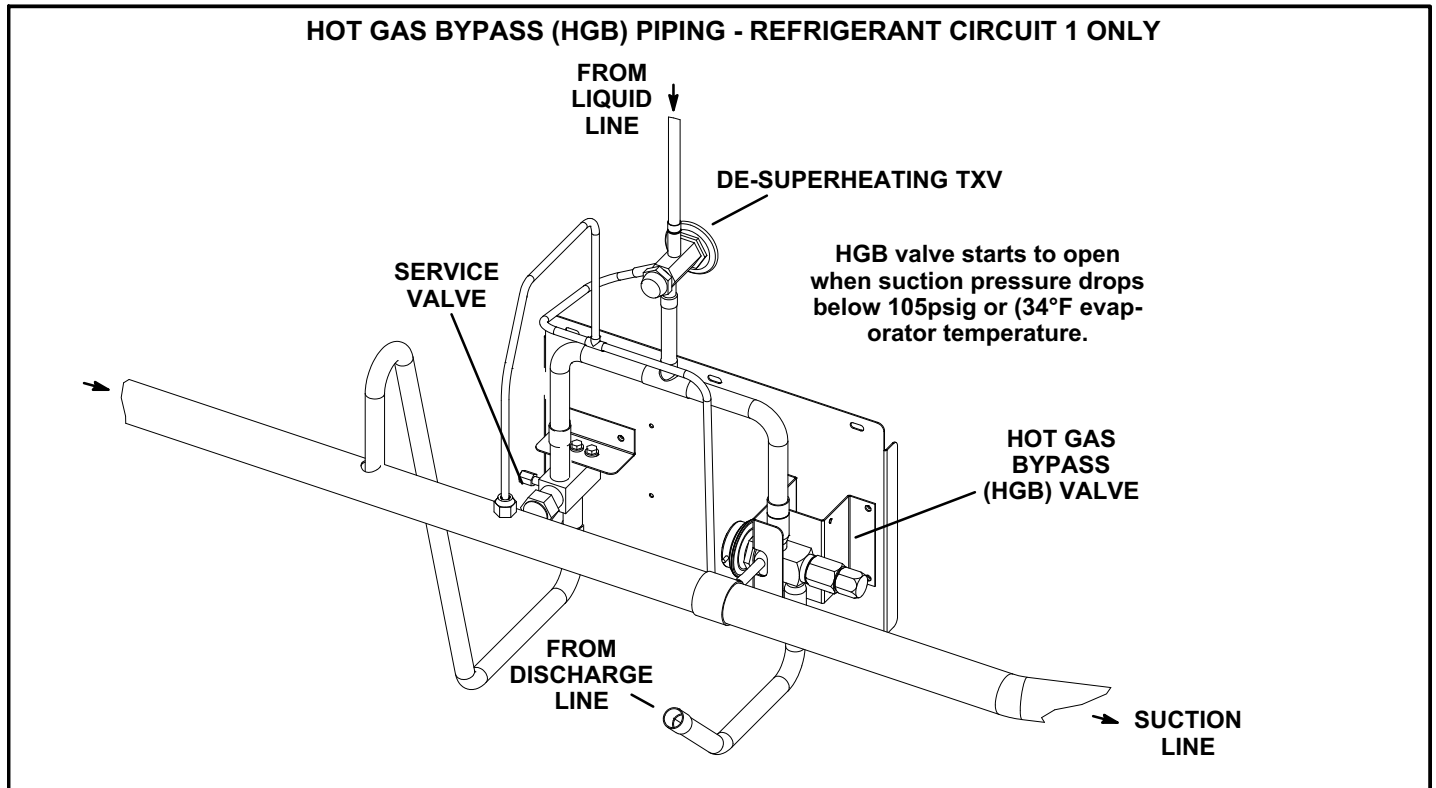

FIGURE 52

Optional Outdoor Air CFM Control

Outdoor air CFM Control is a factory-installed option available on units equipped with a supply air variable frequency drive (VFD) and economizer.

The Unit Controller modulates outdoor air dampers to maintain a constant amount of outdoor air regardless of blower speed. This ensures minimum ventilation requirements are met at lower supply air volumes.

The Unit Controller uses a velocity sensor (A24) to modulate dampers. The sensor is located in the outdoor air stream. See figure 53.

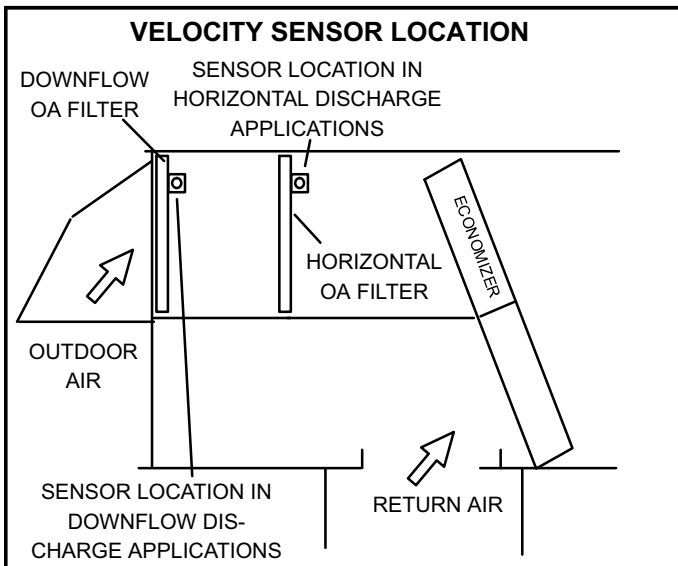

FIGURE 53

Configuration ID Setting

- 1- Enable the Outdoor Air Control feature and set the velocity sensor range using the M3 Unit Controller **SETUP > INSTALL** menu. Navigate to **Configuration ID 1**. Set position **8** to:
H - Outdoor air control installed with A24 control set for high range (0-1968ft/min)
- 2- Make sure the A24 jumper is installed in the low range position as shown in figure 54.
- 3- Operate the blower in high speed and adjust the minimum damper position. Use **SETUP > TEST & BALANCE > DAMPER > MIN DAMPER POSITION** menu. Adjust minimum damper position and press **SAVE**. The Unit Controller will automatically save and display the velocity setpoint. Press **SAVE** again to confirm.

*Note - The minimum damper position setting MUST be set lower than the OAC max damper position setting (50% default). To modify the max damper position setting, navigate to **SETTINGS > EDIT PARAMETERS** and select parameter 117 (DCV MAX DAMPER OPEN).*

Additional outdoor air CFM control settings are available. See parameters 117 and 134 in the Unit Controller manual. Make adjustments through the **SETTINGS > EDIT PARAMETERS** menu; select the required parameter.

- 4- Replace A24 control cover.

NOTE - Refer to local codes or authorities having jurisdiction when determining design minimum outdoor air requirements.

Velocity Sensor Settings

The A24 control is factory-set for 0-10m/s. (0-1968ft/min.)

Note - The configuration ID velocity range must be set to "H" and the jumper setting on the A24 control must be set at low range. No other combinations may be used with the 100501-02 sensor.

The jumper is factory-set at low range (0-1968ft/min).

Note - The configuration ID velocity range must be the same as the jumper setting on the A24 control. The jumper is factory-set at low range (0-1968ft/min).

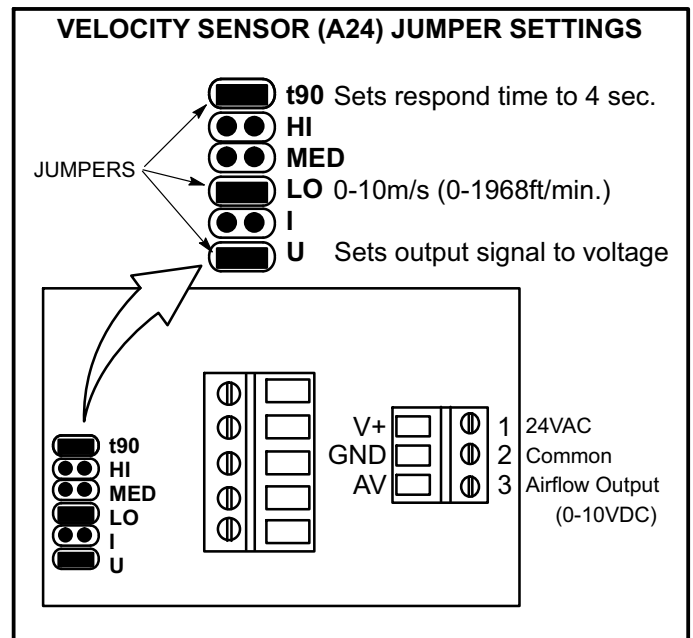

FIGURE 54

Optional Energy Recovery Wheel

Unit may contain an optional energy recovery wheel. The ERW is located in the outdoor air entering and exhaust air streams. In the heating mode, the wheel rotates to transfer heat from the exhaust air stream to the outdoor air intake air stream. In the cooling mode the process reverses. See figure 55.

The ERW motor (B28) is energized when outdoor air is above 65°F (S125) or below 40°F (S23). Refer to wiring diagram on unit panels.

Note - When the outdoor air temperature is between 65°F and 40°F, DL43 will energize the ERW for one minute every ten minutes to clean the wheel.

By-pass dampers will close as outdoor air dampers close or move to minimum position.

ERW should operate on unit start-up unless the outdoor temperature is between 40°F and 65°F. To check ERW operation when outdoor air temperature is between 40°F and 65°F, install a jumper between S125 thermostat terminal "R" and K94 relay coil terminal "A".

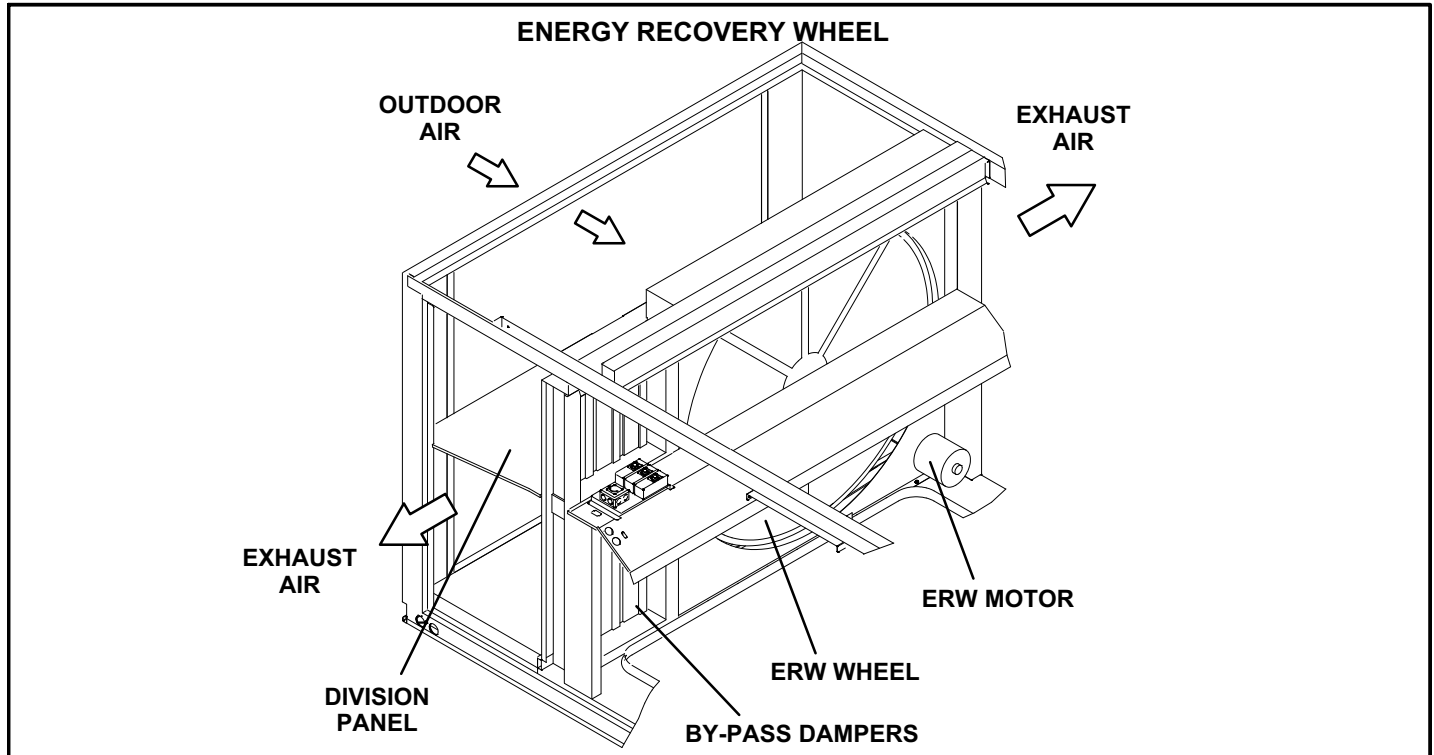

FIGURE 55

Service

⚠ IMPORTANT

Mineral oils are not compatible with R410A. If oil must be added, it must be a polyol ester oil.

⚠ CAUTION

Label all wires prior to disconnection when servicing controls. Wiring errors can cause improper and dangerous operation. Verify proper operation after servicing.

The unit should be inspected once a year by a qualified service technician.

A-Filters

Units are equipped with eleven 16 X 25 X 2" (406 X 635 X 51mm) or 16 X 25 X 4" (406 X 635 X 102mm) supply air filters. Filters should be checked monthly and replaced when necessary with filters of like kind and size. Remove filters as shown in figure 56. Take note of air flow direction marking on filter frame when reinstalling filters. See figure 57 for orientation of replacement filters.

NOTE-Filters must be U.L.C. certified or equivalent for use in Canada.

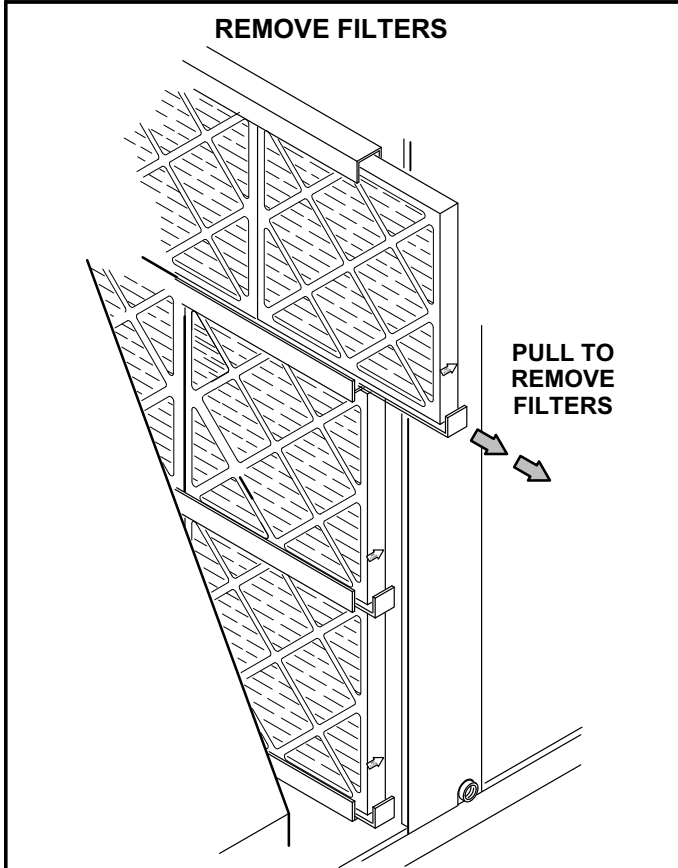

FIGURE 56

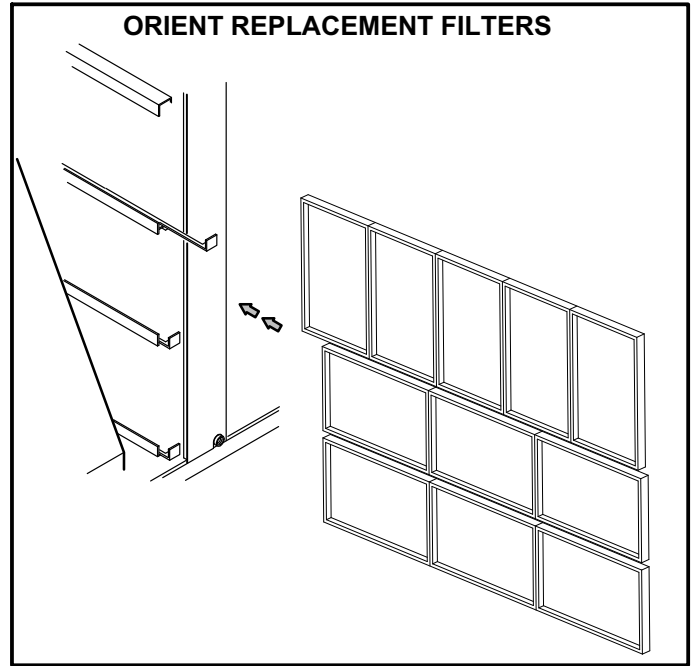

FIGURE 57

Units equipped with optional outdoor air intake hoods contain four 20 X 25 X 2" (508 X 635 X 51mm) aluminum cleanable filters. See figure 58 for location of filters. On horizontal air discharge installations, remove two screws and pivot screen to access filters. See figure 48.

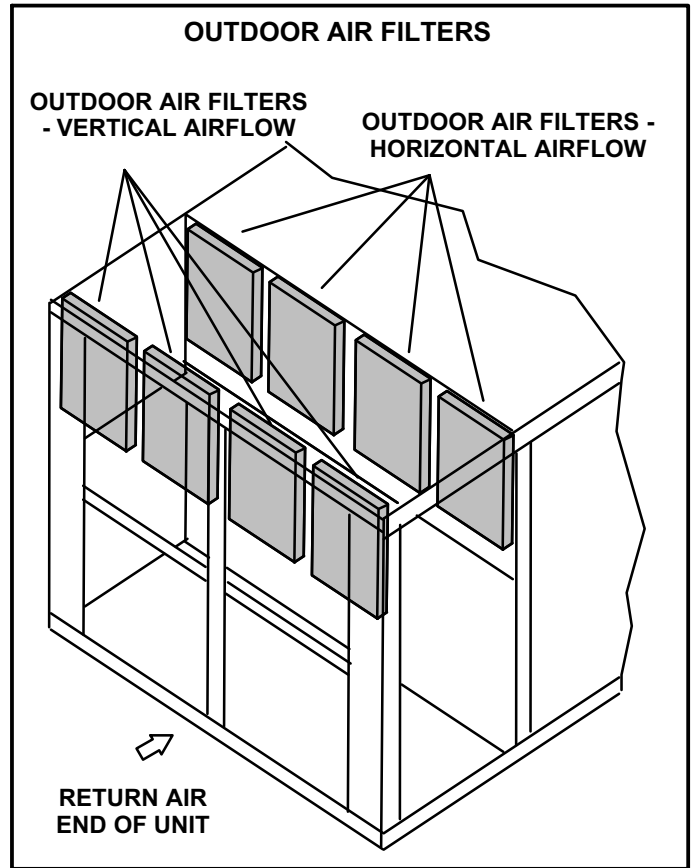

FIGURE 58

B-Lubrication

All motors are lubricated at the factory. No further lubrication is required.

Blower shaft bearings are prelubricated. For extended bearing life, relubricate at least once every two years with a lithium base grease, such as Alvania 3 (Shell Oil), Chevron BRB2 (Standard Oil) or Regal AFB2 (Texas Oil). Use a hand grease gun for relubrication. Add only enough grease to purge through the bearings so that a bead of grease appears at the seal lip contacts.

C-Burners (Gas Units)

- 1- Periodically examine burner flames for proper appearance during the heating season.
- 2- Inspect the position of the flame sensor. Sensor should be centered in the path of the flame.
- 3- Before each heating season examine the burners for any deposits or blockage which may have occurred. Clean burners as follows.
- 4- Turn off the electrical power and gas supply to the unit and open heat section access panel.
- 5- Remove and retain two screws securing burners to the burner support. See figure 59. Clean as necessary. Replace burners and secure with retained screws.

⚠ WARNING	
	Danger of explosion. Can cause injury or death. Do not overtighten main burner mounting screws. Snug tighten only.

- 6- Remove and retain the two screws securing the ignitor to the burner support. Remove the burner and check the spark gap with appropriately sized twist drills or feeler gauges. See figure 60.
- 7- Replace the ignitor and secure in place with retained screws.
- 8- Restore electrical power and gas supply. Follow lighting instructions attached to unit and use inspection port in access panel to check flame.

D-Combustion Air Inducer (Gas Units)

A combustion air proving switch checks combustion air inducer operation before allowing power to the gas controller. Gas controller will not operate if inducer is obstructed.

Under normal operating conditions, the combustion air inducer wheel should be checked and cleaned prior to the heating season. However, it should be examined periodically during the heating season to establish an ideal cleaning schedule. With power supply disconnected, the condition of the inducer wheel can be determined by removing the combustion air inducer.

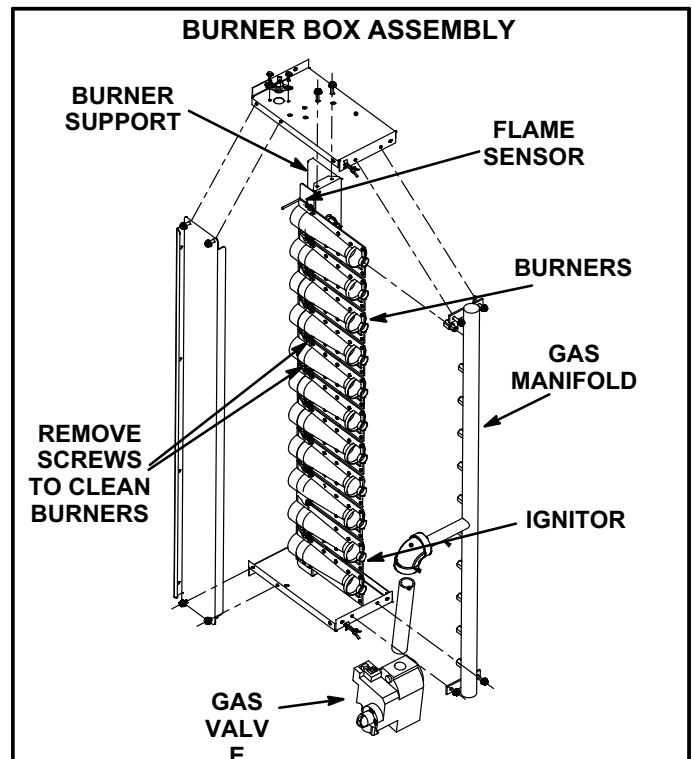

FIGURE 59

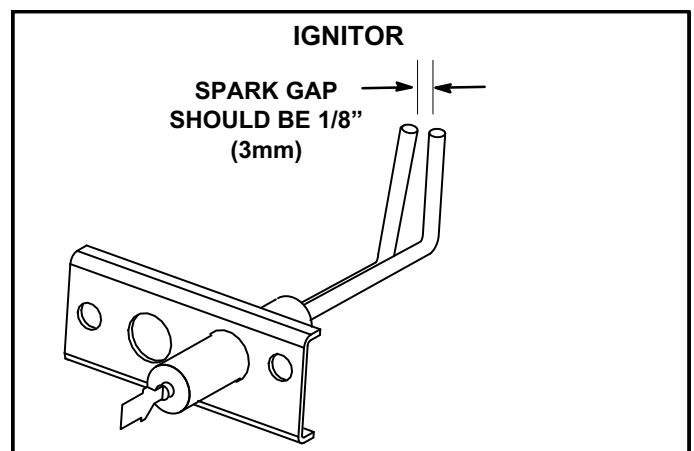

FIGURE 60

Clean combustion air inducer as follows:

- 1- Shut off power supply and gas to unit.
- 2- Disconnect pressure switch air tubing from combustion air inducer port.
- 3- Remove and retain screws securing combustion air inducer to flue box. Remove and retain the screw securing the combustion air inducer to the vent connector. See figure 61.
- 4- Clean inducer wheel blades with a small brush and wipe off any dust from housing. Clean accumulated dust from front of flue box cover.
- 5- Return combustion air inducer motor to the original location and secure with retained screws. It is recommended that the combustion air inducer gasket be replaced during reassembly.
- 6- Clean combustion air inlet louvers on heat access panel using a small brush.

E-Flue Passageway and Flue Box (Gas Units)

- 1- Remove combustion air inducer assembly as described in section D.

2- Remove flue box cover. Clean with a wire brush as required.

3- Reassemble the unit. The flue box cover gasket and combustion air inducer gasket should also be replaced during reassembly.

F-Evaporator Coils

Inspect and clean coils at beginning of each cooling season. Clean using mild detergent or commercial coil cleaner. Flush coil and condensate drain with water taking care not to get insulation, filters and return air ducts wet.

G-Condenser Coils

Clean condenser coils annually with detergent or commercial coil cleaner and inspect monthly during the cooling season. Access panels are provided on front and back of condenser section.

H-Supply Air Blower Wheels

Annually inspect supply air blower wheels for accumulated dirt or dust. Turn off power before attempting to open access panel or to clean blower wheel.

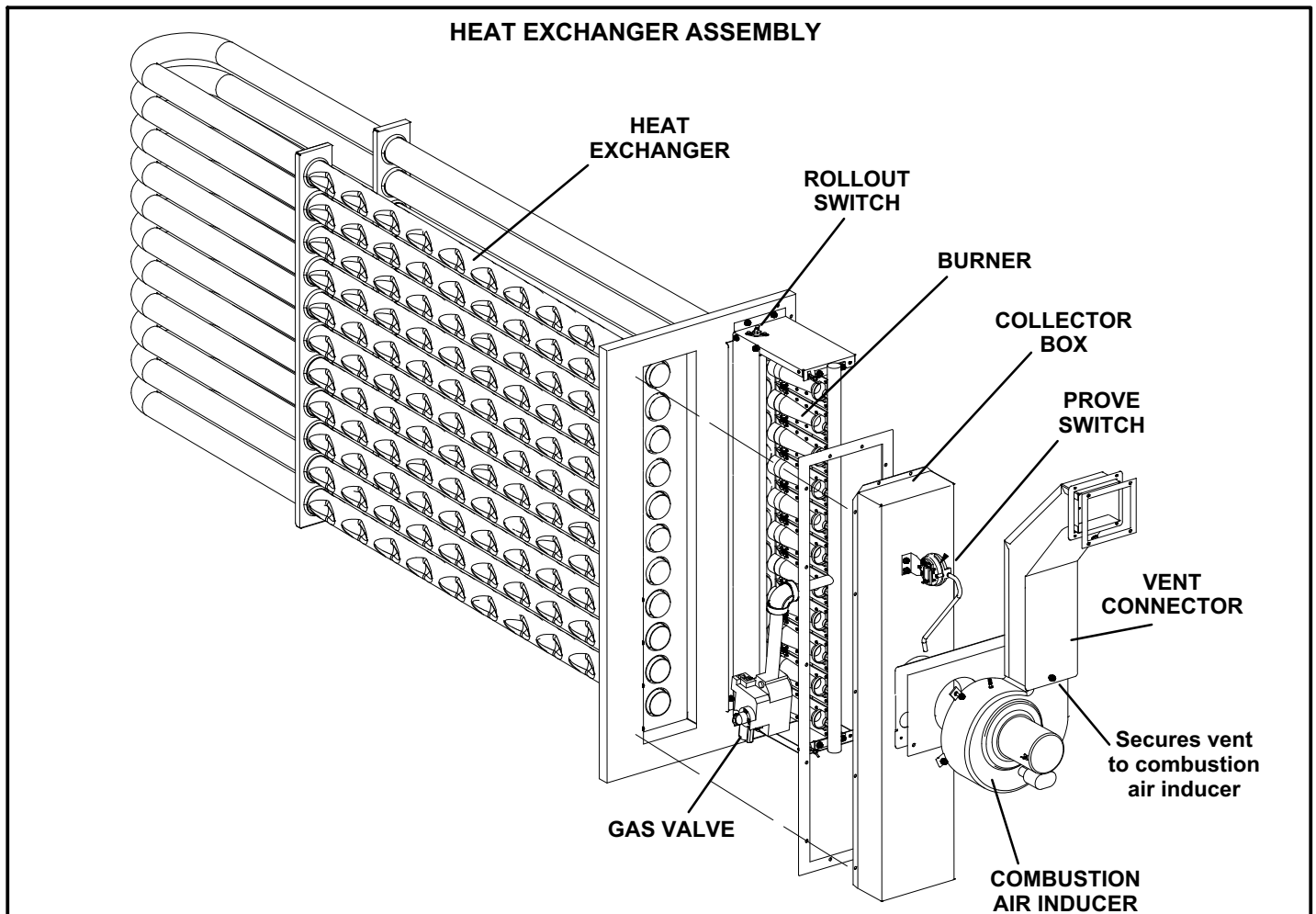

FIGURE 61

START-UP REPORT

Job Name: _____
 Store No. _____ Start-Up Date: _____
 Address: _____
 City: _____ State: _____
 Start-Up Contractor: _____
 Technician: _____
 Model No.: _____
 Serial No.: _____
 RTU No.: _____ Catalog No.: _____

Inspections and Checks			
Damage?	Yes	No	R22 <input type="checkbox"/> R410A <input type="checkbox"/>
If yes, reported to: _____			
Verify factory and field-installed accessories.			
Check electrical connections. Tighten if necessary.			
Supply voltage: L1-L2 _____ L1-L3 _____ L2-L3 _____			
If unit contains a 208-230/240 volt transformer:			
Check primary transformer tap <input type="checkbox"/>			
Transformer secondary voltage: _____			

Cooling Checks												
Compressor Rotation <input type="checkbox"/> Ambient Temp. _____ Return Air Temp. _____ Supply Air Temp. _____												
	Compressor Amps			Compressor Volts			Pressures		Condenser Fan Amps			CC Heater Amps
	L1	L2	L3	L1-L2	L1-L3	L2-L3	Disch.	Suct.	L1	L2	L3	L1
1												
2												
3												
4												

Blower Checks			
Pulley/Belt Alignment	<input type="checkbox"/>	Blower Rotation	<input type="checkbox"/>
Set Screws Tight	<input type="checkbox"/>	Belt Tension	<input type="checkbox"/>
Nameplate Amps: _____		Volts: _____	
Motor	Amps	Volts	
L1	_____	L1-L2	_____
L2	_____	L1-L3	_____
L3	_____	L2-L3	_____

Heating Checks - Electric							
Return Air Temp.: _____ Supply Air Temp.: _____							
Limits Operate: <input type="checkbox"/>							
	Amps						
	L1	L2	L3		L1	L2	L3
1				10			
2				11			
3				12			
4				13			
5				14			
6				15			
7				16			
8				17			
9				18			

Heating Checks - Gas		
Fuel type: Nat. <input type="checkbox"/> LP <input type="checkbox"/> Inlet Pressure: _____ in. w.c.		
Return Air Temp.: _____ Supply Air Temp.: _____		
Altitude: _____ Primary Limits Operate: <input type="checkbox"/>		
Gas Valve	Manifold Pressure	
	Low Fire	High Fire
GV1		
GV2		

Control Type

Accessory Checks	
Power Exhaust Amps	
1 _____	2 _____ None <input type="checkbox"/>
Economizer Operation	
Min. Pos. <input type="checkbox"/>	Motor travel full open/close <input type="checkbox"/>