

INSTALLATION INSTRUCTIONS

⚠️ WARNING

Improper installation, adjustment, alteration, service or maintenance can cause property damage, personal injury or loss of life. Installation and service must be performed by a licensed professional HVAC installer or equivalent, service agency, or the gas supplier

⚠️ CAUTION

As with any mechanical equipment, contact with sharp sheet metal edges can result in personal injury. Take care while handling this equipment and wear gloves and protective clothing.

| | |
|------------------|--------------|
| ZG/ZC 092 | (7.5 Ton) |
| ZG/ZC 102 | (8.5 Ton) |
| ZG/ZC 120 | (10 Ton) |
| ZG/ZC 150 | (12-1/2 Ton) |

GAS AND COOLING PACKAGED UNITS
507256-03
4/2022
Supersedes 7/2018

Table Of Contents

| | |
|---------------------------------|--------|
| Dimensions | Page 2 |
| Parts Arrangements | Page 3 |
| Shipping and Packing List | Page 4 |
| General | Page 4 |
| Safety | Page 4 |
| Unit Support | Page 5 |
| Horizontal Air Discharge | Page 5 |
| Duct Connection | Page 6 |
| Rigging Unit For Lifting | Page 6 |

| | |
|---|---------|
| Condensate Drains | Page 7 |
| Connect Gas Piping | Page 7 |
| Pressure Test Gas Piping | Page 8 |
| High Altitude Derate | Page 8 |
| Electrical Connections | Page 9 |
| Unit Power-Up | Page 10 |
| Blower Operation and Adjustments | Page 10 |
| Cooling Start-Up | Page 18 |
| Gas Heat Start-Up | Page 26 |
| Heating Operation and Adjustments | Page 27 |
| Electric Heat Start-Up | Page 27 |
| Service | Page 28 |

RETAIN THESE INSTRUCTIONS FOR FUTURE REFERENCE

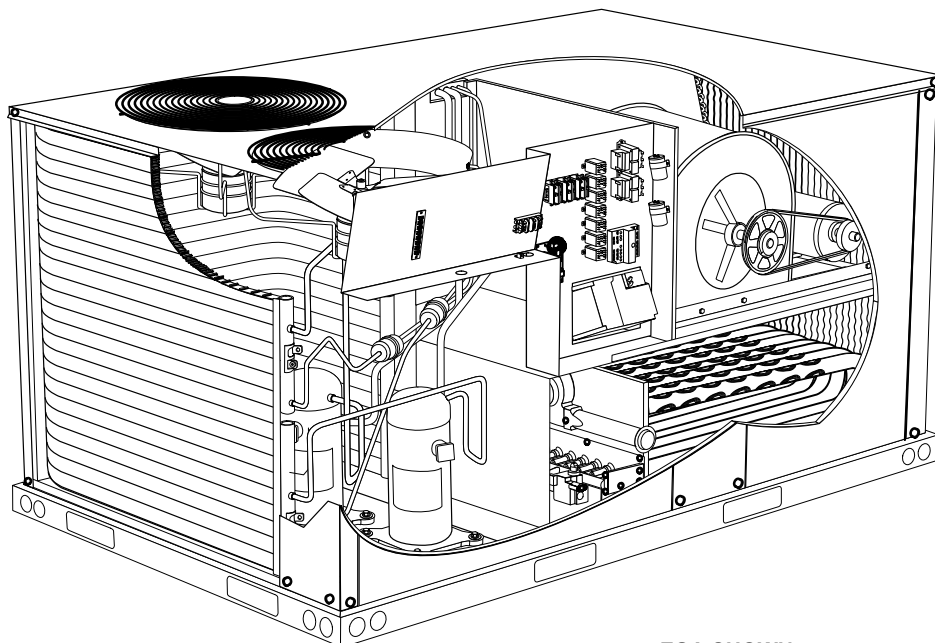

ZGA SHOWN

ZG/ZC 092, 102, 120, & 150 DIMENSIONS - Gas heat section shown

BOTTOM POWER ENTRY

Holes required for Optional Bottom Power Entry Kit

| | Threaded Conduit Fittings (Provided in Kit) | Wire Use | Hole Diameter Required in Unit Base (Max.) |
|----------|---|----------|--|
| A | 1/2 | ACC. | 7/8 (23) |
| B | 1/2 | 24V | 7/8 (23) |
| C | 1-1/4 | POWER | 1-3/4 (44) |
| D | 3/4 | AUX | 1-3/4 (44) |

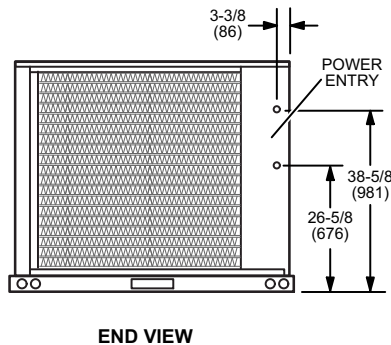
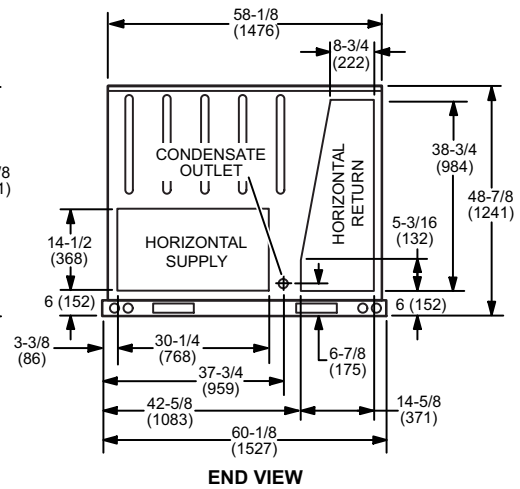
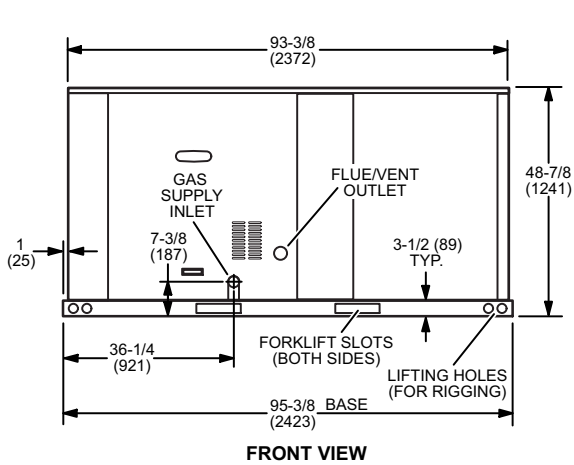
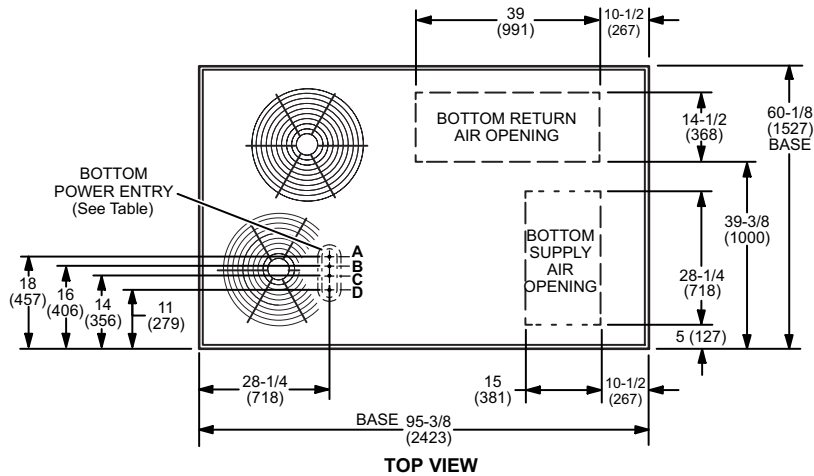

ZG 092, 102, 120, & 150 PARTS ARRANGEMENT

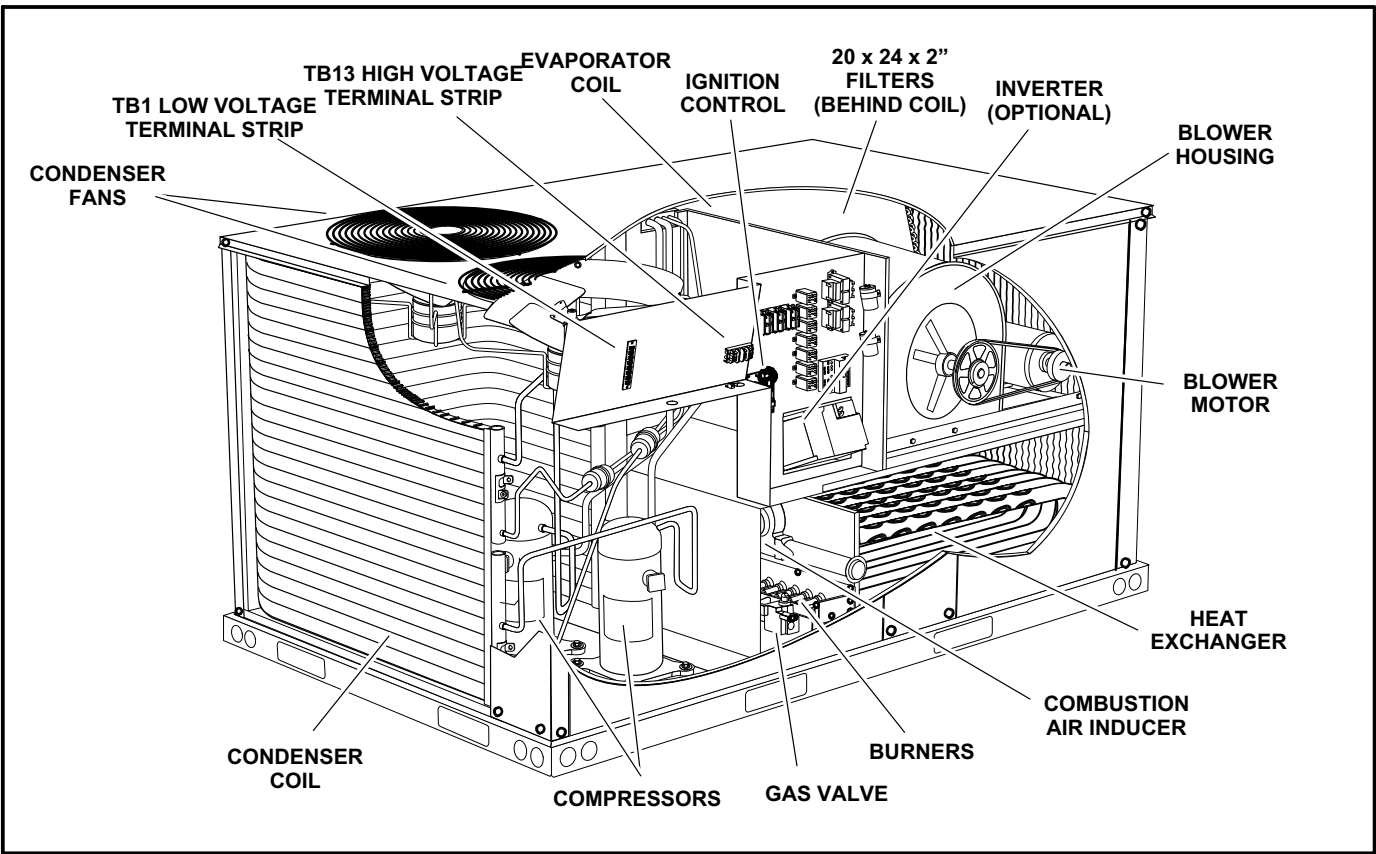

ZC 092, 102, 120, & 150 PARTS ARRANGEMENT

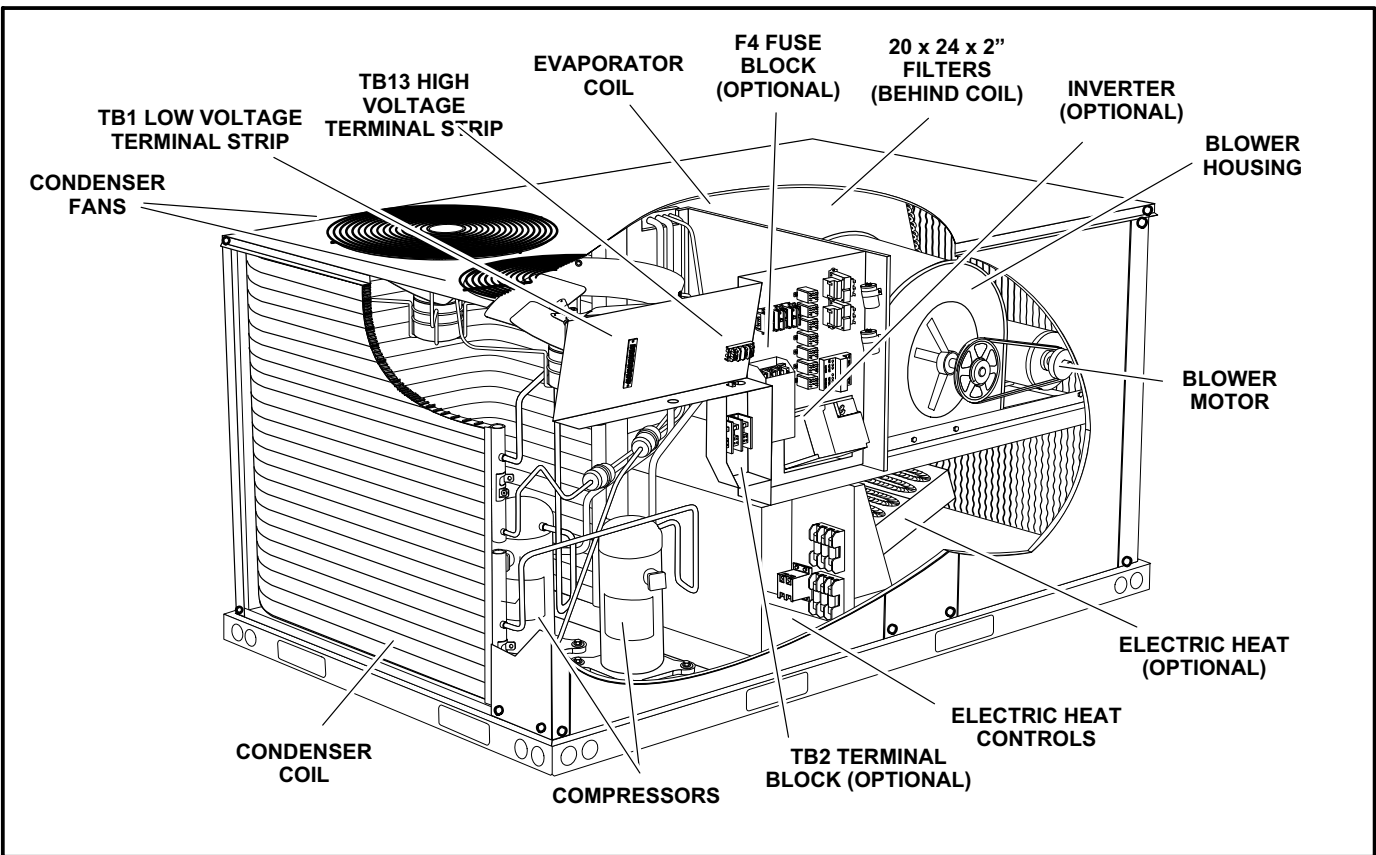

Shipping and Packing List

Package 1 of 1 contains:

1- Assembled unit

Check unit for shipping damage. Receiving party should contact last carrier immediately if shipping damage is found.

General

These instructions are intended as a general guide and do not supersede local codes in any way. Authorities having jurisdiction should be consulted before installation.

The ZG units are available in three heating inputs. The ZC cooling packaged rooftop unit is the same basic design as the ZG unit except for the heating section. Optional electric heat is available for ZC units. ZG and ZC units have identical refrigerant circuits with respective 7-1/2, 8-1/2, 10, and 12-1/2 ton cooling capacities.

Units are available with an optional supply air inverter. During cooling, the blower will operate at lower speeds when demand is low and increase to higher speeds when demand is high. During a blower only demand, the blower will operate at low speed. During a heating demand, the blower will operate at high speed.

Availability of units and options varies by brand.

Safety

See figure 1 for unit clearances.

Use of this unit as a construction heater or air conditioner is not recommended during any phase of construction. Very low return air temperatures, harmful vapors and operation of the unit with clogged or misplaced filters will damage the unit.

⚠ IMPORTANT

The Clean Air Act of 1990 bans the intentional venting of refrigerant (CFC's and HCFC's) as of July 1, 1992. Approved methods of recovery, recycling or reclaiming must be followed. Fines and/or incarceration may be levied for non-compliance.

⚠ WARNING



Electric shock hazard and danger of explosion. Can cause injury, death or product or property damage. Turn off gas and electrical power to unit before performing any maintenance or servicing operations on the unit. Follow lighting instructions attached to unit when putting unit back into operation and after service or maintenance.

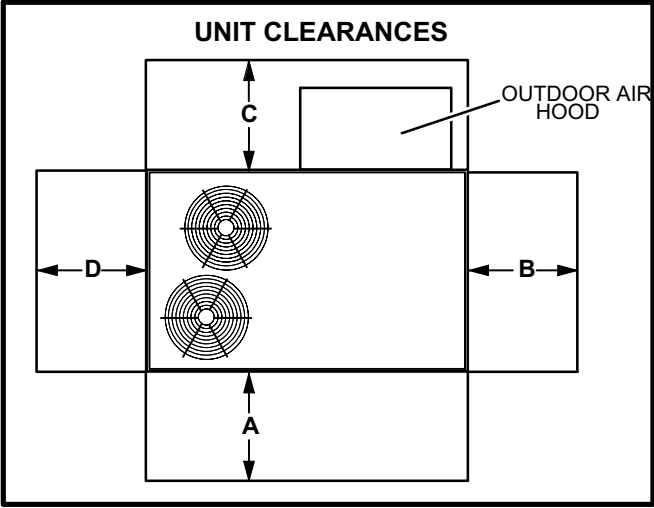

FIGURE 1

| ¹ Unit Clearance | A in.(mm) | B in.(mm) | C in.(mm) | D in.(mm) | Top Clearance |
|-----------------------------|--------------|--------------|--------------|--------------|-------------------|
| Service Clearance | 36 (914) | 36 (914) | 60 (1524) | 36 (914) | Unob- structed |
| Clearance to Combustibles* | 36 (914) | 1 (25) | 1 (25) | 1 (25) | Unob- structed |
| Minimum Operation Clearance | 36 (914) | 36 (914) | 60 (1524) | 36 (914) | Unob- structed |

Note - Entire perimeter of unit base requires support when elevated above mounting surface.

¹ **Service Clearance** - Required for removal of serviceable parts.

Clearance to Combustibles* - Required clearance to combustible material.

Minimum Operation Clearance - Required clearance for proper unit operation.

*Gas units.

⚠ NOTICE

Roof Damage!
This system contains both refrigerant and oil. Some rubber roofing material may absorb oil, causing the rubber to swell. Bubbles in the rubber roofing material can cause leaks. Protect the roof surface to avoid exposure to refrigerant and oil during service and installation. Failure to follow this notice could result in damage to roof surface.

If this unit has been used for heating or cooling of buildings or structures under construction, the following conditions must be met or the warranty will be void:

- A room thermostat must control the unit. The use of fixed jumpers that will provide continuous heating or cooling is not allowed.
- A pre-filter must be installed at the entry to the return air duct.
- The return air duct must be provided and sealed to the unit.
- Return air temperature range between 55°F (13°C) and 80°F (27°C) must be maintained.
- Air filters must be replaced and pre-filters must be removed upon construction completion.

- The input rate and temperature rise must be set per the unit rating plate.
- The heat exchanger, components, duct system, air filters and evaporator coil must be thoroughly cleaned following final construction clean-up.
- The unit operating conditions (including airflow, cooling operation, ignition, input rate, temperature rise and venting) must be verified according to these installation instructions.

Unit Support

In downflow discharge installations, install the unit on a non-combustible surface only. Unit may be installed on combustible surfaces when used in horizontal discharge applications or in downflow discharge applications when installed on an Z1CURB roof mounting frame.

NOTE - Securely fasten roof frame to roof per local codes.

⚠ CAUTION

To reduce the likelihood of supply / return air bypass and promote a proper seal with the RTU, duct work / duct drops / diffuser assemblies must be supported independently to the building structure.

A-Downflow Discharge Application

Roof Mounting with Z1CURB

- 1- The Z1CURB roof mounting frame must be installed, flashed and sealed in accordance with the instructions provided with the frame.
- 2- The Z1CURB roof mounting frame should be square and level to 1/16" per linear foot (5mm per linear meter) in any direction.
- 3- Duct must be attached to the roof mounting frame and not to the unit; supply and return plenums must be installed before setting the unit.

Installer's Roof Mounting Frame

Many types of roof frames can be used to install the unit depending upon different roof structures. Items to keep in mind when using the building frame or supports are:

- 1- The base is fully enclosed and insulated, so an enclosed frame is not required.
- 2- The frames or supports must be constructed with non-combustible materials and should be square and level to 1/16" per linear foot (5mm per linear meter) in any direction.
- 3- Frame or supports must be high enough to prevent any form of moisture from entering unit. Recommended minimum frame height is 14" (356mm).

4- Duct must be attached to the roof mounting frame and not to the unit. Supply and return plenums must be installed before setting the unit.

5- Units require support along all four sides of unit base. Supports must be constructed of steel or suitably treated wood materials.

NOTE-When installing a unit on a combustible surface for downflow discharge applications, an Z1CURB roof mounting frame is required.

B-Horizontal Discharge Applications

- 1- Specified installation clearances must be maintained when installing units. Refer to figure 1.
- 2- Top of support slab should be approximately 4" (102mm) above the finished grade and located so no run-off water from higher ground can collect around the unit.
- 3- Units require support along all four sides of unit base. Supports must be constructed of steel or suitably treated wood materials.

Horizontal Air Discharge

Unit is shipped with panels covering the horizontal supply and return air openings. Remove horizontal covers and place over downflow opening for horizontal air discharge. See figure 2. Secure in place with sheet metal screws.

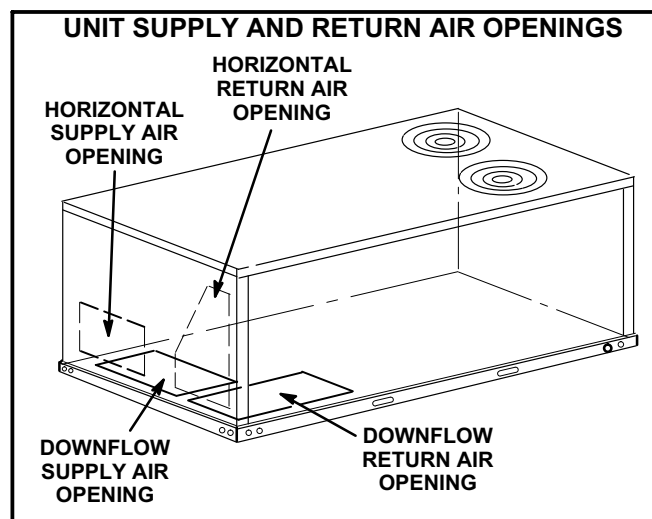

FIGURE 2

Units Equipped With An Optional Horizontal Economizer

- 1- Install the horizontal supply and return air covers over the down flow air openings as described above.
- 2- Install supply and return air ducts on the horizontal supply and return air openings on the unit. See figure 3.
- 3- Horizontal economizer and supply and return air duct must be field-supported.

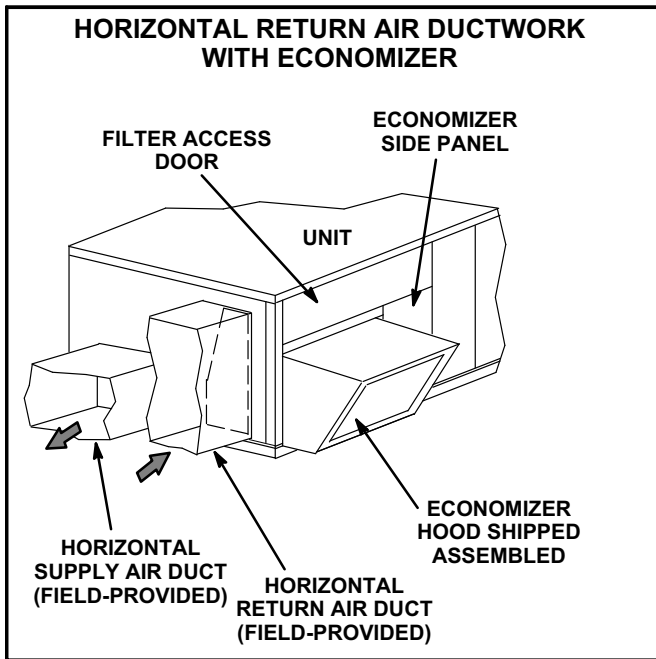

FIGURE 3

Duct Connection

All exterior ducts, joints and openings in roof or building walls must be insulated and weather-proofed with flashing and sealing compounds in accordance with applicable codes. Any duct passing through an unconditioned space must be insulated.

CAUTION

In downflow applications, do not drill or punch holes in base of unit. Leaking in roof may occur if unit base is punctured.

Rigging Unit For Lifting

Rig unit for lifting by attaching four cables to holes in unit base rail. See figure 4.

- 1- Detach wooden base protection before rigging.
- 2- Connect rigging to the unit base using both holes in each corner.
- 3- All panels must be in place for rigging.
- 4- Place field-provided H-style pick in place just above top edge of unit. Frame must be of adequate strength and length. (H-style pick prevents damage to unit.)
- 5- **All Units -** Partially lift unit and remove five (5) L-brackets which secure the protective base board. See figure 4.

Important - Protective wooden base board must be removed before setting unit.

- 6- **New roof curbs (89-3/8" in length) -**
Remove the three alignment brackets shown in figure 5.
- 7- **Existing roof curbs (81-3/4" in length) -**
Set unit on roof curb positioning alignment brackets as shown in figure 5.

RIGGING - ALL UNITS

| Unit | *Weight | |
|------------|---------|-----|
| | Lbs. | Kg. |
| ZGA092-150 | 1203 | 546 |
| ZGB092-120 | | |
| ZGB150 | 1322 | 599 |
| ZCA092-150 | 1168 | 530 |
| ZCB092-120 | | |
| ZCB150 | 1287 | 583 |

LIFTING POINT SHOULD BE DIRECTLY ABOVE CENTER OF GRAVITY

CAUTION - Do not walk on unit.

REMOVE FIVE (5) L-BRACKETS AND BASE PROTECTION BOARD

*Maximum weight with all available installed accessories.
IMPORTANT - ALL PANELS MUST BE IN PLACE FOR RIGGING.

FIGURE 4

UNIT ALIGNMENT BRACKETS

NEW ROOF CURBS (89-3/8" IN LENGTH):
Remove all three brackets.

EXISTING ROOF CURBS (81-3/4" LONG):
Set unit on roof curb positioning alignment brackets as shown.

THREE (3) UNIT ALIGNMENT BRACKETS

ROOF CURB

FIGURE 5

Condensate Drains

Make drain connection to the 1" N.P.T. drain coupling provided on unit.

Note - The drain pan is made with a glass reinforced engineered plastic capable of withstanding typical joint torque but can be damaged with excessive force. Tighten pipe nipple hand tight and turn an additional quarter turn.

A trap must be installed between drain connection and an open vent for proper condensate removal. See figure 6. It is sometimes acceptable to drain condensate onto the roof or grade; however, a tee should be fitted to the trap to direct condensate downward. The condensate line must be vented. Check local codes concerning condensate disposal. Refer to page 2 for condensate drain location.

Units are shipped with the drain coupling facing the right side of the unit. The unit can be installed in either downflow or horizontal air discharge regardless of condensate drain location.

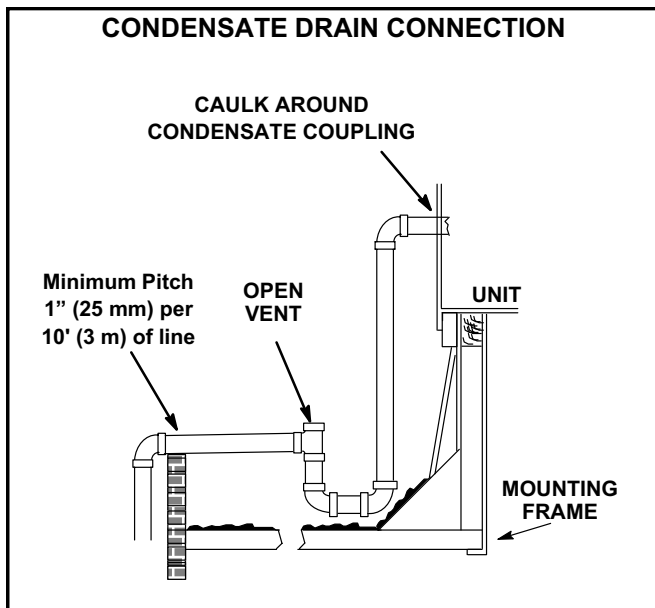

FIGURE 6

Connect Gas Piping (Gas Units)

Before connecting field-provided piping, check with gas company or authorities having jurisdiction for local code requirements. When installing gas supply piping, length of run from gas meter must be considered in determining pipe size for 0.5" w.c. (.12kPa) maximum pressure drop. Do not use supply pipe smaller than unit gas connection. For natural gas units, operating pressure at the unit gas connection must be a minimum of 4.7" w.c. (1.19kPa) and a maximum of 10.5" (2.60kPa) w.c. For LP/propane gas units, operating pressure at the unit gas connection must be a minimum of 11" w.c. (2.74kPa) and a maximum of 13.0" w.c. (3.23kPa).

When making piping connections a drip leg should be installed on vertical pipe runs to serve as a trap for sediment or condensate. A 1/8" N.P.T. plugged tap is located on gas valve for test gauge connection. Refer to Heating Start-Up section for tap location. Install a ground joint union between the gas control manifold and the main manual shut-off valve. See figure 7 for gas supply piping entering outside the unit. Figure 8 shows bottom gas entry piping through the curb.

Compounds used on threaded joints of gas piping shall be resistant to the action of liquified petroleum gases.

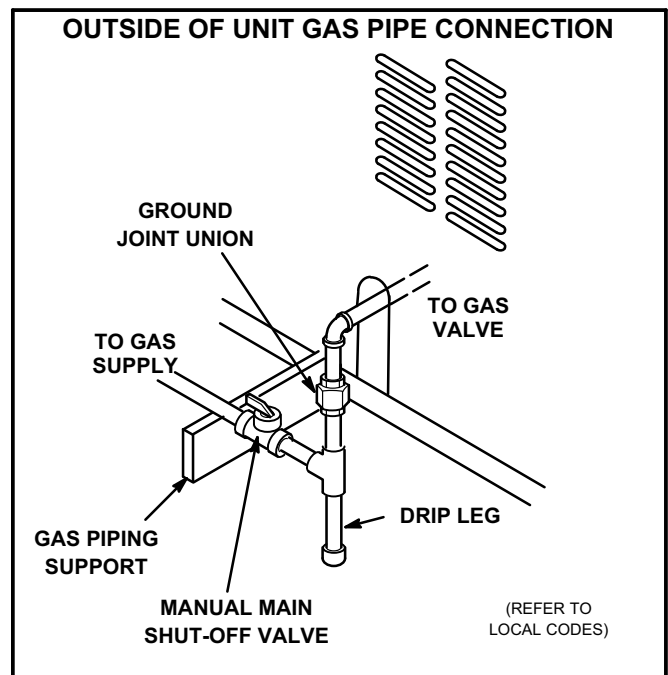

FIGURE 7

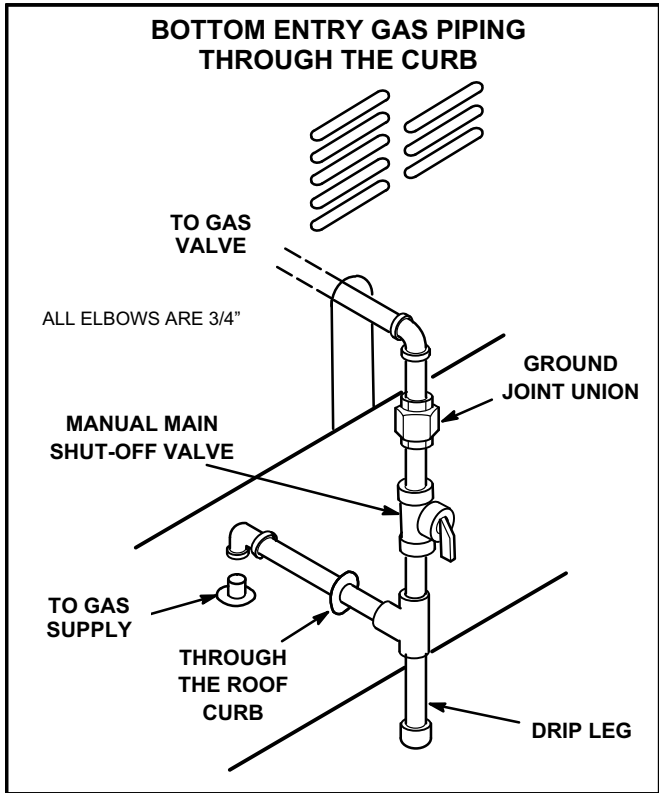

FIGURE 8

Pressure Test Gas Piping (Gas Units)

When pressure testing gas lines, the gas valve must be disconnected and isolated. Gas valves can be damaged if subjected to more than 0.5 psig (3.48kPa). See figure 9.

NOTE-Codes may require that manual main shut-off valve and union (furnished by installer) be installed in gas line external to unit. Union must be of the ground joint type.

After all connections have been made, check all piping connections for gas leaks. Also check existing unit gas connections up to the gas valve; loosening may occur during installation. Use a leak detection solution or other preferred means. Do not use matches candles or other sources of ignition to check for gas leaks.

CAUTION

Some soaps used for leak detection are corrosive to certain metals. Carefully rinse piping thoroughly after leak test has been completed. Do not use matches, candles, flame or othe sources of ignition to check for gas leaks.

WARNING



Danger of explosion. Can cause injury or product or property damage. Do not use matches, candles, flame or other sources of ignition to check for leaks.

NOTE-In case emergency shut down is required, turn off the main manual shut-off valve and disconnect main power to unit. These devices should be properly labeled by the installer.

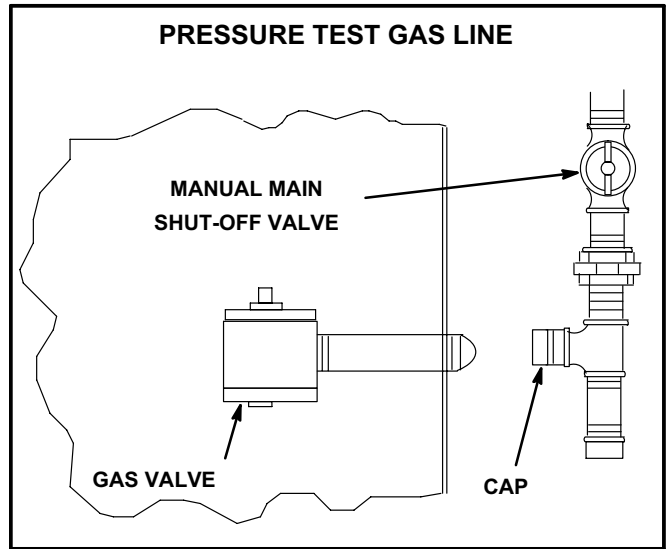

FIGURE 9

High Altitude Derate

Locate the high altitude conversion sticker in the unit literature bag. Fill out the conversion sticker and affix next to the unit nameplate.

Refer to table 1 for high altitude adjustments.

**TABLE 1
HIGH ALTITUDE DERATE**

| Altitude Ft.* | Gas Manifold Pressure |
|----------------|--------------------------------------|
| 2000-4500 | See Unit Nameplate |
| 4500 And Above | Derate 2% / 1000 Ft. Above Sea Level |

*Units installed at 0-2000 feet do not need to be modified.

NOTE - This is the only permissible derate for these units.

Electrical Connections

POWER SUPPLY

A-Wiring

Do not apply power or close disconnect switch until installation is complete. Refer to start-up directions. Refer closely to unit wiring diagram.

Refer to unit nameplate for minimum circuit ampacity and maximum fuse size.

- 1- 230/460/575 volt units are factory wired. **For 208V supply**, disconnect the pink wire (230V) at all control power transformer(s). Reconnect the pink wire (208V). Tape the exposed end of the 230V pink wire.
- 2- Route power through the bottom power entry area and connect to L1, L2, and L3 on the bottom of TB13 in control box. Route power to S48 disconnect switch when the option is factory-installed. See unit wiring diagram.

B-Unbalanced Three-Phase Voltage - VFD Units Only

Units equipped with an optional inverter (VFD) are designed to operate on balanced, three-phase power. Operating units on unbalanced three-phase power will reduce the reliability of all electrical components in the unit. This is not a deficiency in the design of the inverter or a manufacturing issue with the equipment; unbalanced power is a result of the power delivery system supplied by the local utility company.

Factory-installed inverters are sized to drive blower motors with an equivalent current rating using balanced three-phase power. When unbalanced three-phase power is supplied; the installer must replace the existing factory-installed inverter with an inverter that has a higher current rating to allow for the imbalance. Use table 2 to determine the appropriate replacement inverter.

**TABLE 2
INVERTER UP-SIZING**

| Factory-Installed Inverter HP | Replacement Inverter HP |
|-------------------------------|-------------------------|
| 2 | 5 |
| 3 | 7-1/2 |
| 5 | 10 |

CONTROL WIRING

A-Thermostat Location

Room thermostat mounts vertically on a standard 2" X 4" handy box or on any non-conductive flat surface.

Locate thermostat approximately 5 feet (1524mm) above the floor in an area with good air circulation at average temperature. Avoid locating the room thermostat where it might be affected by:

- drafts or dead spots behind doors and in corners
- hot or cold air from ducts
- radiant heat from sun or appliances
- concealed pipes and chimneys

B-Control Wiring

- 1- Route thermostat cable or wires from subbase to control box (refer to unit dimensions to locate bottom and side power entry).

IMPORTANT - Unless field thermostat wires are rated for maximum unit voltage, they must be routed away from line voltage wiring. Use wire ties located near the lower left corner of the controls hat section to secure thermostat cable.

Use 18 AWG wire for all applications using remotely installed electro-mechanical and electronic thermostats.

- 2- Install thermostat assembly in accordance with instructions provided with thermostat.
- 3- Connect thermostat wiring to TB1 terminal board on the left side of the controls area. Wire as shown in figure 10 for electro-mechanical and electronic thermostats. If using other temperature control devices or energy management systems see instructions and wiring diagram provided by manufacturer.

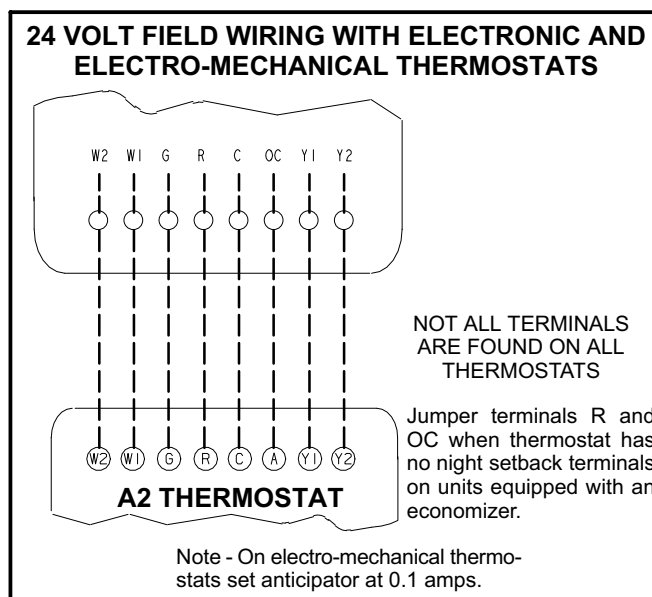

FIGURE 10

IMPORTANT-Terminal connections at the wall plate or subbase must be made securely. Loose control wire connections may allow unit to operate but not with proper response to room demand.

Unit Power-Up

A-General

- 1- Make sure that unit is installed in accordance with the installation instructions and applicable codes.
- 2- Inspect all electrical wiring, both field- and factory-installed, for loose connections. Tighten as required.
- 3- Check to ensure that refrigerant lines do not rub against the cabinet or against other refrigerant lines.
- 4- Check voltage at main unit power connection. Voltage must be within range listed on nameplate. If not, consult power company and have voltage condition corrected before starting unit.
- 5- Make sure filters are in place before start-up.
- 6- Make sure there is no heating, cooling, or blower demand from thermostat. Apply power to unit.

Blower Operation and Adjustments

A-Three Scroll Compressor Voltage Phasing

Three phase scroll compressors must be phased sequentially to ensure correct compressor and blower rotation and operation. Compressor and blower are wired in phase at the factory. Power wires are color-coded as follows: line 1-red, line 2-yellow, line 3-blue.

- 1- Observe suction and discharge pressures and blower rotation on unit start-up.

If pressure differential is not observed or blower rotation is not correct:

- 2- Suction pressure must drop, discharge pressure must rise, and blower rotation must match rotation marking.
- 3- Disconnect all remote electrical power supplies.
- 4- Reverse any two field-installed wires connected to the line side of K3, TB2 or F4. Do not reverse wires at blower contactor or compressors.
- 5- Make sure the connections are tight.

Discharge and suction pressures should operate at their normal start-up ranges.

B-Blower Operation

Initiate blower demand at thermostat according to instructions provided with thermostat. Unit will cycle on thermostat demand. The following steps apply to applications using a typical electro-mechanical thermostat.

- 1- Blower operation is manually set at the thermostat subbase fan switch. With fan switch in **ON** position, blowers will operate continuously.
- 2- With fan switch in **AUTO** position, the blowers will cycle with demand. Blowers and entire unit will be off when system switch is in **OFF** position.

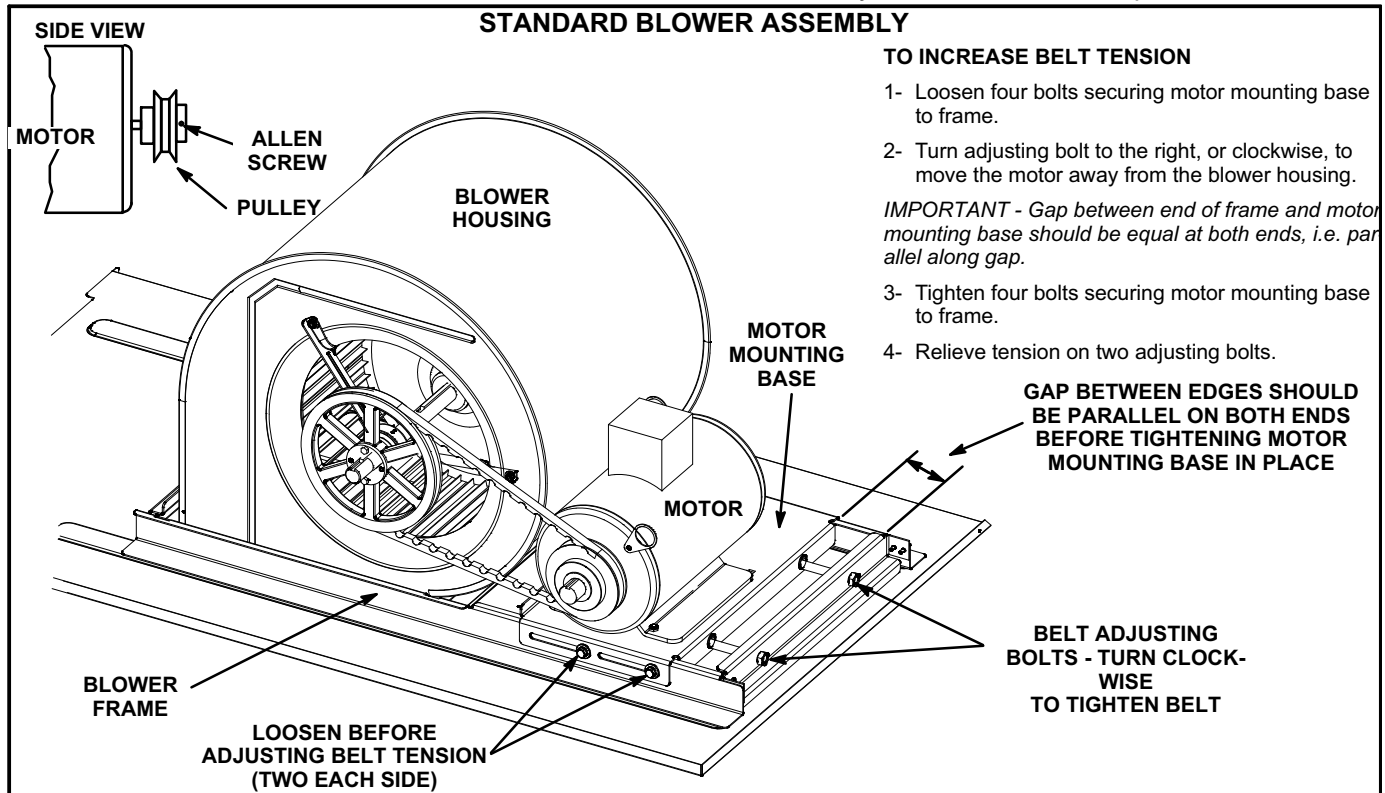

FIGURE 11

C-Determining Unit CFM

1- The following measurements must be made with a dry indoor coil and air filters in place.

*Units **Not** Equipped With An Inverter -*
Run blower without a cooling demand.

Units Equipped With An Inverter -
Initiate high speed blower without a cooling demand. Disconnect high pressure switches S4 and S7. Run the blower with Y1 **and** Y2 demands.

2- Measure the indoor blower shaft RPM.

3- With all access panels in place, measure static pressure external to unit (from supply to return). Blower performance data is based on static pressure readings taken in locations shown in figure 12.

Note - Static pressure readings can vary if not taken where shown.

4- Referring to page 13, 14, or 15, use static pressure and RPM readings to determine unit CFM. Use pages 16 and 17 when installing units with any of the optional accessories listed.

5- The blower RPM can be adjusted at the motor pulley. Loosen Allen screw and turn adjustable pulley clockwise to increase CFM. Turn counterclockwise to decrease CFM. See figure 11. Do not exceed minimum and maximum number of pulley turns as shown in table 3.

6- *Units Equipped With An Inverter -*
Reconnect high pressure switches S4 and S7.

TABLE 3
MINIMUM AND MAXIMUM PULLEY ADJUSTMENT

| Belt | Minimum Turns Open | Maximum Turns Open |
|-----------|--------------------|--------------------|
| A Section | 0 | 5 |
| B Section | 1* | 6 |

*No minimum number of turns open when B belt is used on pulleys 6" O.D. or larger.

D-Blower Belt Adjustment

Maximum life and wear can be obtained from belts only if proper pulley alignment and belt tension are maintained. Tension new belts after a 24-48 hour period of operation. This will allow belt to stretch and seat in the pulley grooves. Make sure blower and motor pulleys are aligned as shown in figure 13.

1- Loosen four bolts securing motor base to mounting frame. See figure 11.

2- *To increase belt tension -*

Turn both adjusting bolts to the right, or clockwise, to move the motor outward and tighten the belt. This increases the distance between the blower motor and the blower housing.

To loosen belt tension -

Turn the adjusting bolts to the left, or counterclockwise to loosen belt tension.

IMPORTANT - Align top edges of blower motor base and mounting frame base parallel before tightening two bolts on the other side of base. Motor shaft and blower shaft must be parallel.

3- Tighten two bolts on each side of the motor mounting base. This secures the mounting base to the frame.

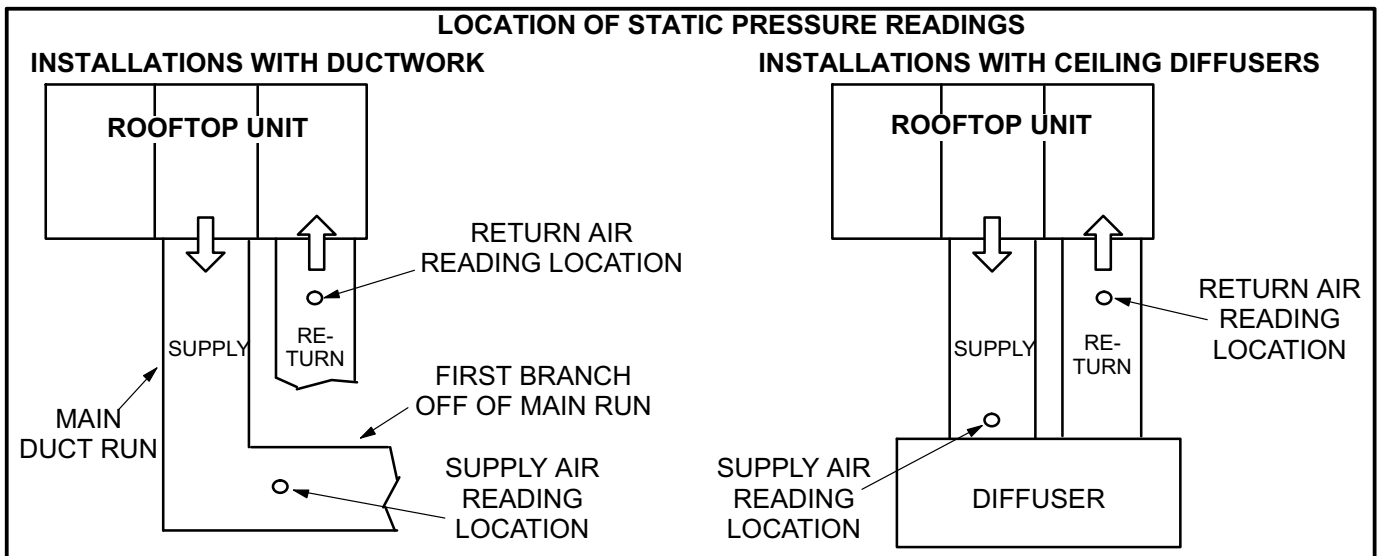

FIGURE 12

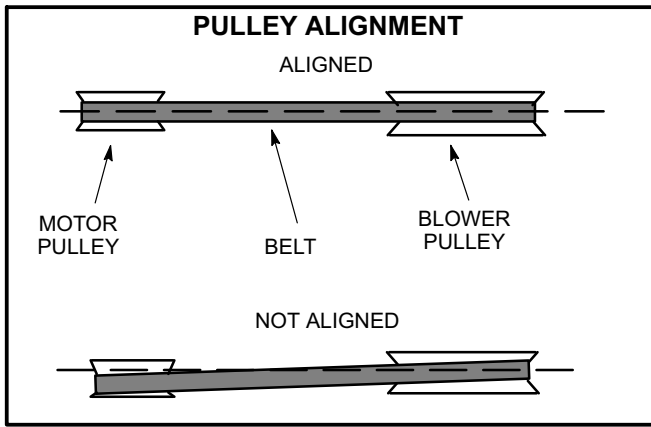

FIGURE 13

E-Check Belt Tension

Overtensioning belts shortens belt and bearing life. Check belt tension as follows:

- 1- Measure span length X. See figure 14.
- 2- Apply perpendicular force to center of span (X) with enough pressure to deflect belt 1/64" for every inch of span length or 1.5mm per 100mm of span length.

Example: Deflection distance of a 40" span would be 40/64" or 5/8".

Example: Deflection distance of a 400mm span would be 6mm.

- 3- Measure belt deflection force. For a new 2 and 3hp belt, the deflection force should be 5.0-7.0 lbs. (35-48kPa). For a new 5hp belt, the deflection force should be 7-10lbs. (48-69kPa).

A force below these values indicates an undertensioned belt. A force above these values indicates an overtensioned belt.

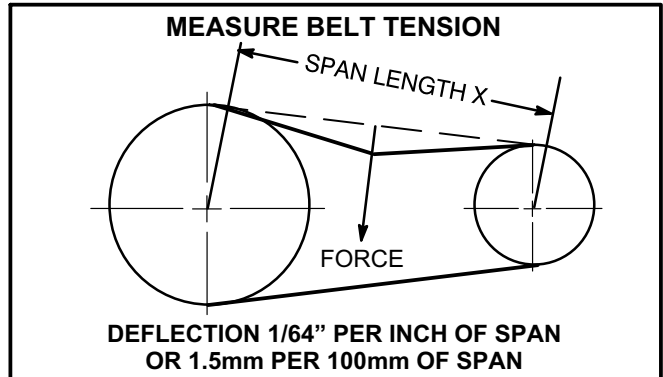

FIGURE 14

F-Field-Furnished Blower Drives

For field-furnished blower drives, use pages 13 through 17 to determine BHP and RPM required. Reference table 4 for drive component manufacturer's numbers.

BLOWER DATA

092S STANDARD EFFICIENCY BELT DRIVE BLOWER – BASE UNIT

BLOWER TABLE INCLUDES RESISTANCE FOR BASE UNIT ONLY (NO HEAT SECTION) WITH DRY INDOOR COIL AND AIR FILTERS IN PLACE. FOR ALL UNITS ADD:

- 1 – Wet indoor coil air resistance of selected unit.
- 2 – Any factory installed options air resistance (heat section, economizer, etc.)
- 3 – Any field installed accessories air resistance (duct resistance, diffuser, etc.)

Then determine from blower table blower motor output required.

See page 17 for blower motors and drives.

See page 17 for wet coil and option/accessory air resistance data.

MAXIMUM STATIC PRESSURE WITH GAS HEAT - 2.0 in. w.g.

MINIMUM AIR VOLUME REQUIRED FOR USE WITH OPTIONAL ELECTRIC HEAT (Maximum Static Pressure - 2.0 in. w.g.)

7.5kW, 15 kW, 22.5 kW - 2065 cfm

30 kW - 2250 cfm

45 kW - 2625 cfm

| Total Air Volume cfm | Total Static Pressure – in. w.g. | | | | | | | | | | | | | | | | | | | | | | | | | |
|----------------------|----------------------------------|------|-----|------|-----|------|-----|------|-----|------|-----|------|------|------|------|------|------|------|------|------|------|------|------|------|------|------|
| | 0.2 | | 0.4 | | 0.6 | | 0.8 | | 1.0 | | 1.2 | | 1.4 | | 1.6 | | 1.8 | | 2 | | 2.2 | | 2.4 | | 2.6 | |
| | RPM | BHP | RPM | BHP | RPM | BHP | RPM | BHP | RPM | BHP | RPM | BHP | RPM | BHP | RPM | BHP | RPM | BHP | RPM | BHP | RPM | BHP | RPM | BHP | RPM | BHP |
| 1750 | 498 | 0.08 | 565 | 0.25 | 633 | 0.50 | 701 | 0.71 | 768 | 0.87 | 830 | 0.99 | 890 | 1.08 | 946 | 1.16 | 998 | 1.27 | 1049 | 1.41 | 1098 | 1.58 | --- | --- | --- | --- |
| 2000 | 512 | 0.12 | 578 | 0.37 | 645 | 0.60 | 713 | 0.81 | 780 | 0.97 | 842 | 1.10 | 901 | 1.19 | 955 | 1.28 | 1007 | 1.40 | 1057 | 1.56 | 1105 | 1.74 | 1153 | 1.94 | 1201 | 2.16 |
| 2250 | 527 | 0.24 | 592 | 0.49 | 659 | 0.72 | 727 | 0.92 | 793 | 1.08 | 855 | 1.21 | 913 | 1.32 | 966 | 1.42 | 1017 | 1.55 | 1066 | 1.72 | 1114 | 1.92 | 1162 | 2.13 | 1210 | 2.35 |
| 2500 | 543 | 0.37 | 608 | 0.61 | 675 | 0.84 | 743 | 1.04 | 809 | 1.21 | 869 | 1.35 | 926 | 1.45 | 978 | 1.57 | 1028 | 1.72 | 1076 | 1.90 | 1124 | 2.11 | 1171 | 2.33 | 1221 | 2.57 |
| 2750 | 560 | 0.51 | 625 | 0.75 | 693 | 0.98 | 761 | 1.18 | 826 | 1.35 | 885 | 1.49 | 939 | 1.60 | 990 | 1.73 | 1039 | 1.90 | 1087 | 2.10 | 1135 | 2.32 | 1183 | 2.55 | 1232 | 2.80 |
| 3000 | 579 | 0.66 | 645 | 0.90 | 713 | 1.13 | 781 | 1.34 | 844 | 1.51 | 901 | 1.65 | 954 | 1.77 | 1004 | 1.92 | 1052 | 2.11 | 1100 | 2.32 | 1147 | 2.56 | 1195 | 2.80 | 1245 | 3.05 |
| 3250 | 600 | 0.82 | 666 | 1.06 | 735 | 1.30 | 803 | 1.51 | 864 | 1.69 | 918 | 1.82 | 969 | 1.95 | 1018 | 2.12 | 1066 | 2.34 | 1113 | 2.57 | 1161 | 2.81 | 1209 | 3.06 | 1259 | 3.31 |
| 3500 | 622 | 0.98 | 690 | 1.24 | 760 | 1.49 | 826 | 1.70 | 883 | 1.87 | 936 | 2.01 | 985 | 2.16 | 1033 | 2.35 | 1081 | 2.59 | 1128 | 2.84 | 1176 | 3.09 | 1224 | 3.34 | 1275 | 3.60 |
| 3750 | 646 | 1.17 | 716 | 1.45 | 786 | 1.70 | 849 | 1.91 | 903 | 2.07 | 953 | 2.21 | 1002 | 2.38 | 1049 | 2.61 | 1097 | 2.87 | 1144 | 3.12 | 1192 | 3.38 | 1241 | 3.64 | 1292 | 3.91 |
| 4000 | 674 | 1.38 | 746 | 1.68 | 814 | 1.93 | 872 | 2.12 | 923 | 2.28 | 971 | 2.43 | 1019 | 2.64 | 1067 | 2.90 | 1114 | 3.17 | 1161 | 3.43 | 1209 | 3.69 | 1259 | 3.96 | 1311 | 4.24 |
| 4250 | 705 | 1.63 | 777 | 1.94 | 841 | 2.17 | 894 | 2.34 | 943 | 2.50 | 990 | 2.69 | 1038 | 2.93 | 1085 | 3.21 | 1132 | 3.49 | 1179 | 3.76 | 1228 | 4.03 | 1279 | 4.31 | 1332 | 4.60 |

BLOWER DATA

102S STANDARD EFFICIENCY BELT DRIVE BLOWER – BASE UNIT

BLOWER TABLE INCLUDES RESISTANCE FOR BASE UNIT ONLY (NO HEAT SECTION) WITH DRY INDOOR COIL AND AIR FILTERS IN PLACE. FOR ALL UNITS ADD:

1 – Wet indoor coil air resistance of selected unit.

2 – Any factory installed options air resistance (heat section, economizer, etc.)

3 – Any field installed accessories air resistance (duct resistance, diffuser, etc.)

Then determine from blower table blower motor output required.

See page 17 for blower motors and drives.

See page 17 for wet coil and option/accessory air resistance data.

MAXIMUM STATIC PRESSURE WITH GAS HEAT - 2.0 in. w.g.

MINIMUM AIR VOLUME REQUIRED FOR USE WITH OPTIONAL ELECTRIC HEAT (Maximum Static Pressure - 2.0 in. w.g.)

7.5kW, 15 kW, 22.5 kW - 2065 cfm

30 kW - 2250 cfm

45 kW - 2625 cfm

| Total Air Volume cfm | Total Static Pressure – in. w.g. | | | | | | | | | | | | | | | | | | | | | | | | | | |
|----------------------|----------------------------------|------|-----|------|-----|------|-----|------|-----|------|------|------|------|------|------|------|------|------|------|------|------|------|------|------|------|------|-----|
| | 0.2 | | 0.4 | | 0.6 | | 0.8 | | 1.0 | | 1.2 | | 1.4 | | 1.6 | | 1.8 | | 2.0 | | 2.2 | | 2.4 | | 2.6 | | |
| | RPM | BHP | RPM | BHP | RPM | BHP | RPM | BHP | RPM | BHP | RPM | BHP | RPM | BHP | RPM | BHP | RPM | BHP | RPM | BHP | RPM | BHP | RPM | BHP | RPM | BHP | RPM |
| 1750 | 494 | 0.11 | 562 | 0.34 | 632 | 0.56 | 702 | 0.74 | 771 | 0.85 | 838 | 0.96 | 902 | 1.07 | 961 | 1.19 | --- | --- | --- | --- | --- | --- | --- | --- | --- | --- | --- |
| 2000 | 514 | 0.26 | 581 | 0.49 | 650 | 0.70 | 719 | 0.87 | 786 | 0.98 | 852 | 1.09 | 915 | 1.20 | 972 | 1.32 | 1026 | 1.47 | 1076 | 1.65 | --- | --- | --- | --- | --- | --- | --- |
| 2250 | 533 | 0.41 | 599 | 0.62 | 667 | 0.82 | 735 | 0.99 | 802 | 1.10 | 866 | 1.21 | 928 | 1.33 | 984 | 1.46 | 1037 | 1.63 | 1085 | 1.81 | 1132 | 2.01 | 1178 | 2.21 | 1226 | 2.43 | --- |
| 2500 | 553 | 0.55 | 619 | 0.76 | 685 | 0.95 | 753 | 1.10 | 818 | 1.22 | 881 | 1.34 | 942 | 1.47 | 997 | 1.62 | 1048 | 1.80 | 1096 | 1.99 | 1142 | 2.20 | 1188 | 2.41 | 1237 | 2.64 | --- |
| 2750 | 573 | 0.70 | 638 | 0.90 | 705 | 1.08 | 771 | 1.22 | 835 | 1.35 | 897 | 1.49 | 957 | 1.63 | 1011 | 1.80 | 1061 | 1.99 | 1108 | 2.19 | 1154 | 2.41 | 1200 | 2.63 | 1249 | 2.87 | --- |
| 3000 | 594 | 0.85 | 659 | 1.05 | 725 | 1.22 | 791 | 1.36 | 853 | 1.50 | 915 | 1.65 | 973 | 1.81 | 1026 | 1.99 | 1075 | 2.20 | 1121 | 2.42 | 1167 | 2.64 | 1213 | 2.87 | 1262 | 3.12 | --- |
| 3250 | 617 | 1.01 | 682 | 1.20 | 747 | 1.37 | 812 | 1.52 | 873 | 1.67 | 934 | 1.83 | 990 | 2.01 | 1042 | 2.21 | 1089 | 2.43 | 1135 | 2.66 | 1181 | 2.90 | 1228 | 3.13 | 1277 | 3.38 | --- |
| 3500 | 640 | 1.17 | 706 | 1.36 | 771 | 1.53 | 834 | 1.70 | 895 | 1.86 | 954 | 2.03 | 1008 | 2.23 | 1058 | 2.46 | 1105 | 2.69 | 1150 | 2.93 | 1196 | 3.17 | 1243 | 3.41 | 1293 | 3.65 | --- |
| 3750 | 665 | 1.34 | 731 | 1.54 | 796 | 1.72 | 857 | 1.89 | 917 | 2.07 | 975 | 2.26 | 1027 | 2.48 | 1076 | 2.72 | 1121 | 2.97 | 1166 | 3.22 | 1212 | 3.46 | 1261 | 3.71 | 1311 | 3.96 | --- |
| 4000 | 692 | 1.54 | 758 | 1.75 | 822 | 1.93 | 882 | 2.11 | 940 | 2.30 | 996 | 2.51 | 1047 | 2.76 | 1094 | 3.02 | 1139 | 3.27 | 1184 | 3.52 | 1230 | 3.77 | 1280 | 4.03 | 1330 | 4.29 | --- |
| 4250 | 722 | 1.76 | 787 | 1.97 | 849 | 2.15 | 908 | 2.35 | 965 | 2.56 | 1018 | 2.79 | 1067 | 3.06 | 1113 | 3.33 | 1157 | 3.59 | 1202 | 3.85 | 1250 | 4.11 | 1300 | 4.38 | 1352 | 4.65 | --- |

BLOWER DATA

ZGA/ZCA120S STANDARD EFFICIENCY BELT DRIVE BLOWER – BASE UNIT

BLOWER TABLE INCLUDES RESISTANCE FOR BASE UNIT ONLY (NO HEAT SECTION) WITH DRY INDOOR COIL AND AIR FILTERS IN PLACE. FOR ALL UNITS ADD:

- 1 – Wet indoor coil air resistance of selected unit.
- 2 – Any factory installed options air resistance (heat section, economizer, etc.)
- 3 – Any field installed accessories air resistance (duct resistance, diffuser, etc.)

Then determine from blower table blower motor output required.

See page 17 for blower motors and drives.

See page 17 for wet coil and option/accessory air resistance data.

MAXIMUM STATIC PRESSURE WITH GAS HEAT - 2.0 in. w.g.

MINIMUM AIR VOLUME REQUIRED FOR USE WITH OPTIONAL ELECTRIC HEAT (Maximum Static Pressure - 2.0 in. w.g.)

15 kW - 22.5 kW - 2065 cfm

30 kW - 2250 cfm

45 kW - 2625 cfm

60 kW - 3500 cfm

| Total Air Volume cfm | Total Static Pressure – in. w.g. | | | | | | | | | | | | | | | | | | | | | | | | | | | |
|----------------------|----------------------------------|------|-----|------|-----|------|-----|------|------|------|------|------|------|------|------|------|------|------|------|------|------|------|------|------|------|------|-----|-----|
| | 0.2 | | 0.4 | | 0.6 | | 0.8 | | 1.0 | | 1.2 | | 1.4 | | 1.6 | | 1.8 | | 2 | | 2.2 | | 2.4 | | 2.6 | | | |
| | RPM | BHP | RPM | BHP | RPM | BHP | RPM | BHP | RPM | BHP | RPM | BHP | RPM | BHP | RPM | BHP | RPM | BHP | RPM | BHP | RPM | BHP | RPM | BHP | RPM | BHP | RPM | BHP |
| 2000 | 535 | 0.28 | 596 | 0.49 | 660 | 0.69 | 724 | 0.87 | 788 | 1.00 | 851 | 1.11 | 913 | 1.23 | 971 | 1.37 | 1025 | 1.52 | 1076 | 1.69 | 1124 | 1.86 | --- | --- | --- | --- | --- | --- |
| 2250 | 552 | 0.43 | 613 | 0.63 | 675 | 0.81 | 738 | 0.98 | 802 | 1.11 | 864 | 1.22 | 925 | 1.36 | 982 | 1.51 | 1036 | 1.68 | 1085 | 1.85 | 1133 | 2.04 | 1180 | 2.23 | 1228 | 2.44 | --- | --- |
| 2500 | 570 | 0.57 | 630 | 0.76 | 692 | 0.94 | 754 | 1.10 | 817 | 1.22 | 879 | 1.35 | 939 | 1.51 | 995 | 1.67 | 1047 | 1.85 | 1096 | 2.04 | 1143 | 2.23 | 1190 | 2.43 | 1239 | 2.65 | --- | --- |
| 2750 | 589 | 0.72 | 648 | 0.91 | 709 | 1.08 | 772 | 1.22 | 833 | 1.36 | 894 | 1.50 | 954 | 1.67 | 1009 | 1.85 | 1059 | 2.04 | 1108 | 2.24 | 1154 | 2.44 | 1202 | 2.65 | 1251 | 2.87 | --- | --- |
| 3000 | 608 | 0.87 | 668 | 1.05 | 729 | 1.22 | 791 | 1.37 | 852 | 1.51 | 912 | 1.67 | 970 | 1.85 | 1023 | 2.05 | 1073 | 2.25 | 1120 | 2.46 | 1167 | 2.67 | 1215 | 2.89 | 1265 | 3.11 | --- | --- |
| 3250 | 629 | 1.03 | 688 | 1.21 | 749 | 1.37 | 811 | 1.52 | 871 | 1.68 | 930 | 1.86 | 987 | 2.06 | 1039 | 2.27 | 1088 | 2.49 | 1134 | 2.70 | 1181 | 2.92 | 1229 | 3.14 | 1279 | 3.37 | --- | --- |
| 3500 | 651 | 1.20 | 710 | 1.38 | 772 | 1.54 | 833 | 1.70 | 892 | 1.88 | 950 | 2.07 | 1004 | 2.28 | 1055 | 2.51 | 1103 | 2.74 | 1150 | 2.96 | 1196 | 3.19 | 1245 | 3.42 | 1295 | 3.65 | --- | --- |
| 3750 | 674 | 1.36 | 734 | 1.56 | 796 | 1.73 | 856 | 1.90 | 914 | 2.10 | 970 | 2.30 | 1023 | 2.53 | 1072 | 2.78 | 1120 | 3.02 | 1166 | 3.25 | 1213 | 3.47 | 1262 | 3.71 | 1313 | 3.95 | --- | --- |
| 4000 | 699 | 1.55 | 761 | 1.76 | 822 | 1.94 | 880 | 2.12 | 936 | 2.33 | 991 | 2.56 | 1042 | 2.81 | 1090 | 3.07 | 1137 | 3.31 | 1183 | 3.55 | 1231 | 3.78 | 1281 | 4.03 | 1333 | 4.28 | --- | --- |
| 4250 | 726 | 1.77 | 789 | 1.98 | 849 | 2.16 | 904 | 2.37 | 959 | 2.59 | 1012 | 2.84 | 1062 | 3.11 | 1109 | 3.38 | 1156 | 3.63 | 1202 | 3.87 | 1251 | 4.11 | 1302 | 4.37 | 1354 | 4.63 | --- | --- |
| 4500 | 756 | 2.01 | 818 | 2.22 | 875 | 2.41 | 929 | 2.63 | 983 | 2.88 | 1034 | 3.15 | 1082 | 3.44 | 1129 | 3.71 | 1175 | 3.96 | 1222 | 4.21 | 1271 | 4.46 | 1323 | 4.72 | 1376 | 5.00 | --- | --- |
| 4750 | 788 | 2.27 | 848 | 2.47 | 902 | 2.68 | 955 | 2.92 | 1006 | 3.20 | 1056 | 3.50 | 1104 | 3.79 | 1150 | 4.06 | 1196 | 4.32 | 1243 | 4.57 | 1293 | 4.83 | 1345 | 5.09 | 1399 | 5.37 | --- | --- |
| 5000 | 822 | 2.54 | 878 | 2.75 | 929 | 2.98 | 980 | 3.25 | 1031 | 3.56 | 1079 | 3.87 | 1126 | 4.16 | 1172 | 4.44 | 1218 | 4.70 | 1266 | 4.95 | 1315 | 5.20 | 1367 | 5.47 | 1421 | 5.74 | --- | --- |

BLOWER DATA

ZGB/ZCB120S & ZG/ZC 150S STANDARD EFFICIENCY BELT DRIVE BLOWER – BASE UNIT

BLOWER TABLE INCLUDES RESISTANCE FOR BASE UNIT ONLY (NO HEAT SECTION) WITH DRY INDOOR COIL AND AIR FILTERS IN PLACE. FOR ALL UNITS ADD:

- 1 – Wet indoor coil air resistance of selected unit.
- 2 – Any factory installed options air resistance (heat section, economizer, etc.)
- 3 – Any field installed accessories air resistance (duct resistance, diffuser, etc.)

Then determine from blower table blower motor output required.

See page 17 for blower motors and drives.

See page 17 for wet coil and option/accessory air resistance data.

MAXIMUM STATIC PRESSURE WITH GAS HEAT - 2.0 in. w.g.

MINIMUM AIR VOLUME REQUIRED FOR USE WITH OPTIONAL ELECTRIC HEAT (Maximum Static Pressure - 2.0 in. w.g.)

15 kW, 22.5 kW - 2065 cfm

30 kW - 2250 cfm

45 kW - 2625 cfm

60 kW - 3500 cfm

| Total Air Volume cfm | Total Static Pressure – in. w.g. | | | | | | | | | | | | | | | | | | | | | | | | | | | |
|----------------------|----------------------------------|------|------|------|------|------|------|------|------|------|------|------|------|------|------|------|------|------|------|------|------|------|------|------|------|------|-----|-----|
| | 0.2 | | 0.4 | | 0.6 | | 0.8 | | 1.0 | | 1.2 | | 1.4 | | 1.6 | | 1.8 | | 2.0 | | 2.2 | | 2.4 | | 2.6 | | | |
| | RPM | BHP | RPM | BHP | RPM | BHP | RPM | BHP | RPM | BHP | RPM | BHP | RPM | BHP | RPM | BHP | RPM | BHP | RPM | BHP | RPM | BHP | RPM | BHP | RPM | BHP | RPM | BHP |
| 2000 | 542 | 0.43 | 602 | 0.60 | 664 | 0.75 | 732 | 0.89 | 802 | 1.02 | 869 | 1.15 | 927 | 1.27 | 979 | 1.41 | 1029 | 1.57 | 1079 | 1.75 | 1129 | 1.95 | 1179 | 2.15 | 1230 | 2.37 | | |
| 2250 | 560 | 0.55 | 619 | 0.71 | 681 | 0.86 | 748 | 1.00 | 817 | 1.14 | 882 | 1.27 | 939 | 1.41 | 991 | 1.57 | 1041 | 1.74 | 1090 | 1.93 | 1140 | 2.13 | 1190 | 2.35 | 1241 | 2.57 | | |
| 2500 | 579 | 0.68 | 637 | 0.83 | 699 | 0.98 | 766 | 1.12 | 834 | 1.26 | 897 | 1.41 | 953 | 1.57 | 1005 | 1.74 | 1054 | 1.92 | 1103 | 2.12 | 1152 | 2.33 | 1202 | 2.55 | 1254 | 2.79 | | |
| 2750 | 599 | 0.81 | 657 | 0.97 | 719 | 1.11 | 785 | 1.25 | 851 | 1.41 | 913 | 1.57 | 968 | 1.74 | 1020 | 1.93 | 1068 | 2.13 | 1116 | 2.34 | 1165 | 2.56 | 1215 | 2.78 | 1268 | 3.01 | | |
| 3000 | 620 | 0.95 | 678 | 1.11 | 741 | 1.25 | 806 | 1.40 | 870 | 1.58 | 930 | 1.75 | 985 | 1.94 | 1036 | 2.14 | 1084 | 2.36 | 1131 | 2.58 | 1180 | 2.80 | 1230 | 3.02 | 1283 | 3.26 | | |
| 3250 | 643 | 1.10 | 701 | 1.26 | 764 | 1.41 | 828 | 1.57 | 891 | 1.76 | 950 | 1.95 | 1003 | 2.16 | 1053 | 2.38 | 1100 | 2.61 | 1148 | 2.83 | 1196 | 3.06 | 1246 | 3.29 | 1299 | 3.52 | | |
| 3500 | 667 | 1.26 | 726 | 1.43 | 788 | 1.58 | 851 | 1.77 | 913 | 1.97 | 970 | 2.17 | 1023 | 2.41 | 1071 | 2.65 | 1118 | 2.88 | 1165 | 3.11 | 1213 | 3.33 | 1264 | 3.57 | 1317 | 3.81 | | |
| 3750 | 693 | 1.44 | 752 | 1.61 | 813 | 1.78 | 876 | 1.98 | 936 | 2.20 | 992 | 2.43 | 1043 | 2.68 | 1091 | 2.93 | 1137 | 3.17 | 1183 | 3.40 | 1232 | 3.64 | 1284 | 3.88 | 1338 | 4.13 | | |
| 4000 | 720 | 1.65 | 779 | 1.82 | 840 | 2.00 | 902 | 2.22 | 961 | 2.46 | 1015 | 2.71 | 1064 | 2.98 | 1111 | 3.24 | 1156 | 3.48 | 1203 | 3.72 | 1253 | 3.96 | 1305 | 4.22 | 1359 | 4.48 | | |
| 4250 | 748 | 1.86 | 807 | 2.04 | 868 | 2.24 | 929 | 2.48 | 986 | 2.75 | 1038 | 3.02 | 1086 | 3.30 | 1132 | 3.57 | 1177 | 3.81 | 1224 | 4.05 | 1274 | 4.31 | 1327 | 4.57 | 1382 | 4.85 | | |
| 4500 | 778 | 2.09 | 837 | 2.28 | 898 | 2.51 | 957 | 2.78 | 1012 | 3.07 | 1062 | 3.37 | 1108 | 3.65 | 1154 | 3.92 | 1199 | 4.17 | 1247 | 4.41 | 1297 | 4.67 | 1350 | 4.94 | 1405 | 5.22 | | |
| 4750 | 809 | 2.34 | 868 | 2.56 | 929 | 2.82 | 986 | 3.12 | 1038 | 3.43 | 1087 | 3.74 | 1132 | 4.03 | 1177 | 4.29 | 1223 | 4.54 | 1270 | 4.79 | 1321 | 5.04 | 1374 | 5.31 | 1428 | 5.58 | | |
| 5000 | 841 | 2.62 | 901 | 2.87 | 960 | 3.17 | 1015 | 3.50 | 1065 | 3.83 | 1112 | 4.14 | 1157 | 4.43 | 1201 | 4.69 | 1247 | 4.94 | 1295 | 5.18 | 1345 | 5.42 | 1398 | 5.68 | --- | --- | | |
| 5250 | 875 | 2.93 | 935 | 3.23 | 992 | 3.56 | 1044 | 3.91 | 1092 | 4.26 | 1138 | 4.57 | 1182 | 4.85 | 1226 | 5.10 | 1272 | 5.34 | 1320 | 5.57 | --- | --- | --- | --- | --- | --- | | |
| 5500 | 911 | 3.30 | 969 | 3.63 | 1024 | 4.00 | 1074 | 4.37 | 1120 | 4.71 | 1165 | 5.02 | 1208 | 5.29 | 1253 | 5.53 | --- | --- | --- | --- | --- | --- | --- | --- | --- | --- | | |
| 5750 | 948 | 3.71 | 1004 | 4.08 | 1056 | 4.48 | 1104 | 4.85 | 1148 | 5.19 | 1192 | 5.49 | 1235 | 5.74 | --- | --- | --- | --- | --- | --- | --- | --- | --- | --- | --- | --- | | |
| 6000 | 985 | 4.18 | 1039 | 4.59 | 1088 | 5.00 | 1134 | 5.37 | 1177 | 5.69 | --- | --- | --- | --- | --- | --- | --- | --- | --- | --- | --- | --- | --- | --- | --- | --- | | |
| 6250 | 1022 | 4.70 | 1073 | 5.14 | 1120 | 5.54 | --- | --- | --- | --- | --- | --- | --- | --- | --- | --- | --- | --- | --- | --- | --- | --- | --- | --- | --- | --- | | |

BLOWER DATA

FACTORY INSTALLED BELT DRIVE KIT SPECIFICATIONS

| Nominal hp | Maximum hp | Drive Kit Number | RPM Range |
|------------|------------|------------------|-------------|
| 2 | 2.3 | 1 | 590 - 890 |
| 2 | 2.3 | 2 | 800 - 1105 |
| 2 | 2.3 | 3 | 795 - 1195 |
| 3 | 3.45 | 4 | 730 - 970 |
| 3 | 3.45 | 5 | 940 - 1200 |
| 3 | 3.45 | 6 | 1015 - 1300 |
| 5 | 5.75 | 10 | 900 - 1135 |
| 5 | 5.75 | 11 | 1040 - 1315 |
| 5 | 5.75 | 12 | 1125 - 1425 |

NOTE - Using total air volume and system static pressure requirements determine from blower performance tables rpm and motor output required. Maximum usable output of motors furnished are shown. In Canada, nominal motor output is also maximum usable motor output. If motors of comparable output are used, be sure to keep within the service factor limitations outlined on the motor nameplate.

NOTE - Units equipped with option are limited to a motor service factor of 1.0.

POWER EXHAUST FAN PERFORMANCE

| Return Air System Static Pressure | Air Volume Exhausted |
|-----------------------------------|----------------------|
| in. w.g. | cfm |
| 0 | 3175 |
| 0.05 | 2955 |
| 0.10 | 2685 |
| 0.15 | 2410 |
| 0.20 | 2165 |
| 0.25 | 1920 |
| 0.30 | 1420 |
| 0.35 | 1200 |

FACTORY INSTALLED OPTIONS/FIELD INSTALLED ACCESSORY AIR RESISTANCE - in. w.g.

| Air Volume cfm | Wet Indoor Coil | | | Gas Heat Exchanger | | | Electric Heat | Economizer | Filters | |
|----------------|-----------------|-----------------|-----------------------|--------------------|-------------|-----------|---------------|------------|---------|---------|
| | 092 | 102, ZGA/ZCA120 | ZGB/ZCB120 & ZG/ZC150 | Standard Heat | Medium Heat | High Heat | | | MERV 8 | MERV 13 |
| 1750 | 0.02 | 0.03 | 0.04 | 0.06 | 0.02 | 0.02 | 0.03 | 0.03 | 0.01 | 0.03 |
| 2000 | 0.02 | 0.04 | 0.05 | 0.07 | 0.05 | 0.06 | 0.03 | 0.05 | 0.01 | 0.03 |
| 2250 | 0.03 | 0.05 | 0.06 | 0.07 | 0.07 | 0.08 | 0.04 | 0.06 | 0.01 | 0.04 |
| 2500 | 0.03 | 0.05 | 0.07 | 0.09 | 0.10 | 0.11 | 0.04 | 0.08 | 0.01 | 0.05 |
| 2750 | 0.04 | 0.06 | 0.08 | 0.09 | 0.11 | 0.12 | 0.05 | 0.09 | 0.02 | 0.05 |
| 3000 | 0.05 | 0.07 | 0.09 | 0.11 | 0.12 | 0.13 | 0.06 | 0.11 | 0.02 | 0.06 |
| 3250 | 0.05 | 0.08 | 0.10 | 0.12 | 0.15 | 0.16 | 0.06 | 0.13 | 0.02 | 0.06 |
| 3500 | 0.06 | 0.09 | 0.11 | 0.12 | 0.16 | 0.17 | 0.09 | 0.15 | 0.03 | 0.07 |
| 3750 | 0.07 | 0.10 | 0.13 | 0.14 | 0.19 | 0.20 | 0.09 | 0.17 | 0.03 | 0.08 |
| 4000 | 0.07 | 0.11 | 0.14 | 0.14 | 0.21 | 0.22 | 0.09 | 0.19 | 0.04 | 0.08 |
| 4250 | 0.08 | 0.13 | 0.15 | 0.14 | 0.24 | 0.28 | 0.13 | 0.21 | 0.04 | 0.09 |
| 4500 | 0.09 | 0.14 | 0.17 | 0.15 | 0.26 | 0.32 | 0.14 | 0.24 | 0.04 | 0.09 |
| 4750 | 0.10 | 0.15 | 0.18 | 0.16 | 0.29 | 0.37 | 0.17 | 0.26 | 0.05 | 0.10 |
| 5000 | 0.10 | 0.16 | 0.20 | 0.16 | 0.34 | 0.43 | 0.20 | 0.29 | 0.06 | 0.10 |
| 5250 | 0.11 | 0.17 | 0.22 | 0.16 | 0.37 | 0.47 | 0.22 | 0.32 | 0.06 | 0.11 |
| 5500 | 0.12 | 0.19 | 0.23 | 0.18 | 0.44 | 0.54 | 0.25 | 0.34 | 0.07 | 0.12 |
| 5750 | 0.13 | 0.20 | 0.25 | 0.19 | 0.49 | 0.59 | 0.31 | 0.37 | 0.07 | 0.12 |
| 6000 | 0.14 | 0.22 | 0.27 | 0.20 | 0.54 | 0.64 | 0.33 | 0.40 | 0.08 | 0.13 |

**TABLE 4
MANUFACTURER'S NUMBERS**

| DRIVE NO. | DRIVE COMPONENTS | | | | | |
|-----------|-------------------|--------------|--------------|--------------|--------------|--------------|
| | ADJUSTABLE SHEAVE | | FIXED SHEAVE | | BELT | |
| | BROWNING NO. | OEM PART NO. | BROWNING NO. | OEM PART NO. | BROWNING NO. | OEM PART NO. |
| 1 | 1VP34x7/8 | 31K6901 | AK61x1 | 100244-20 | A44 | 44L5501 |
| 2 | 1VP40x7/8 | 79J0301 | AK59x1 | 31K6801 | AX45 | 100245-23 |
| 3 | 1VP34x7/8 | 31K6901 | AK46x1 | 100244-17 | A41 | 100245-18 |
| 4 | 1VP44x7/8 | P-8-1488 | AK74x1 | 100244-21 | AX48 | 100245-50 |
| 5 | 1VP50x7/8 | P-8-2187 | AK69x1 | 37L4701 | AX48 | 100245-50 |
| 6 | 1VP50x7/8 | P-8-2187 | AK64x1 | 12L2501 | AX46 | 31K7101 |
| 10 | 1VP50x1-1/8 | P-8-1977 | BK77x1 | 49K4001 | BX50 | 100245-49 |
| 11 | 1VP50x1-1/8 | P-8-1977 | BK67x1 | 100244-24 | BX46 | 100245-48 |
| 12 | 1VP50x1-1/8 | P-8-1977 | BK62x1 | 100244-23 | BX46 | 100245-48 |

Cooling Start-Up

A-Operation

1- Initiate first and second stage cooling demands according to instructions provided with thermostat.

2- *No Economizer Installed in Unit -*

A first-stage cooling demand (Y1) will energize compressor 1 and both condenser fans. An increased cooling demand (Y2) will energize compressor 2.

Units Equipped With Economizer -

When outdoor air is acceptable, a first-stage cooling demand (Y1) will energize the economizer. An increased cooling demand (Y2) will energize compressor 1 and both condenser fans. When outdoor air is not acceptable unit will operate as though no economizer is installed.

3- Units contain two refrigerant circuits or stages. See figure 15 or 16.

4- Each refrigerant circuit is separately charged with R-410A refrigerant. See unit rating plate for correct amount of charge.

5- Refer to Cooling Operation and Adjustment section for proper method to check refrigerant charge.

B-Refrigerant Charge and Check - All-Aluminum Coil

WARNING-Do not exceed nameplate charge under any condition.

This unit is factory charged and should require no further adjustment. If the system requires additional refrigerant, reclaim the charge, evacuate the system, and add required nameplate charge.

*NOTE - System charging is not recommended below 60°F (15°C). In temperatures below 60°F (15°C), the charge **must** be weighed into the system.*

If weighing facilities are not available, or to check the charge, use the following procedure:

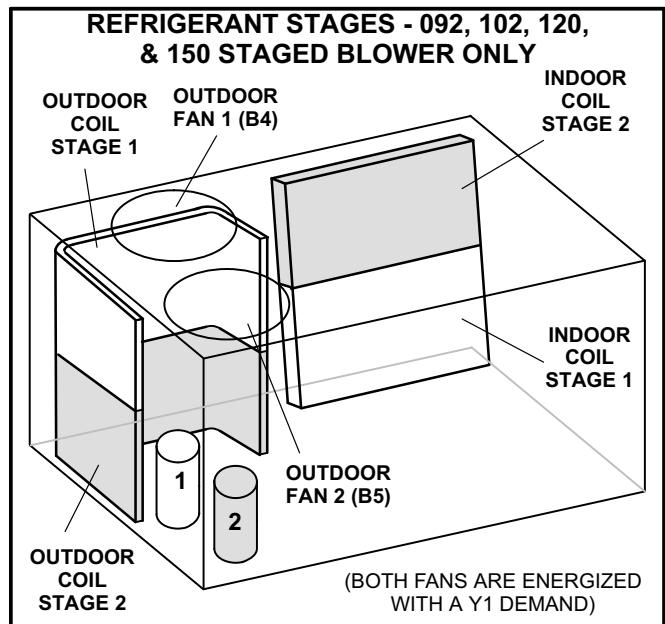

FIGURE 15

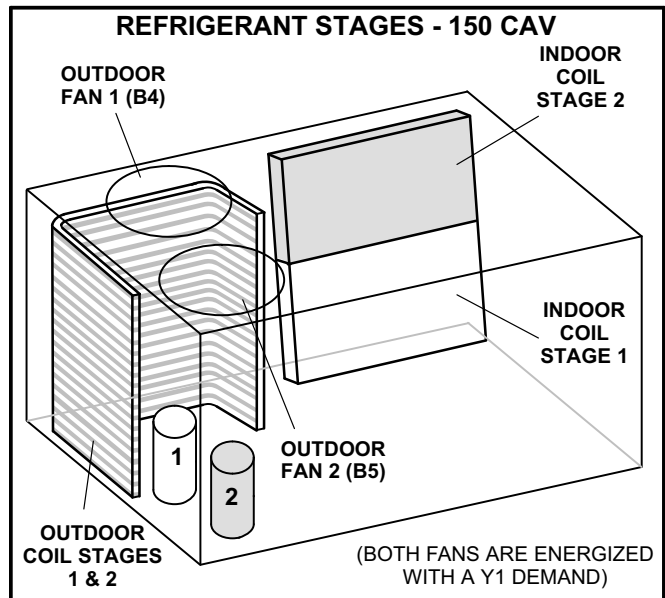

FIGURE 16

IMPORTANT - Charge unit in standard cooling mode.

- 1- Make sure outdoor coil is clean. Attach gauge manifolds and operate unit at full CFM in cooling mode with economizer disabled until system stabilizes (approximately five minutes). Make sure all outdoor air dampers are closed.
- 2- Check each system separately with all stages operating. Compare the normal operating pressures (see tables 5 - 10) to the pressures obtained from the gauges. Check unit components if there are significant differences.
- 3- Measure the outdoor ambient temperature and the suction pressure. Refer to the appropriate circuit charging curve to determine a target liquid temperature.

Note - Pressures are listed for sea level applications.

- 4- Use the same thermometer to accurately measure the liquid temperature (in the outdoor section).

- If measured liquid temperature is higher than the target liquid temperature, add refrigerant to the system.

- If measured liquid temperature is lower than the target liquid temperature, recover some refrigerant from the system.

- 5- Add or remove charge in increments. Allow the system to stabilize each time refrigerant is added or removed.

- 6- Continue the process until measured liquid temperature agrees with the target liquid temperature. Do not go below the target liquid temperature when adjusting charge. Note that suction pressure can change as charge is adjusted.

- 7- Example ZG/ZC 092S Circuit 1: At 95°F outdoor ambient and a measured suction pressure of 130psig, the target liquid temperature is 100.5°F. For a measured liquid temperature of 106°F, add charge in increments until measured liquid temperature agrees with the target liquid temperature.

TABLE 5

| ZGA/ZCA092S4M (Staged) & ZGB/ZCB092S4B (CAV) Normal Operating Pressures | | | | | | | | | | | | |
|--|---------------------------------------|-------------|-------------|-------------|-------------|-------------|-------------|-------------|-------------|-------------|-------------|-------------|
| | Outdoor Coil Entering Air Temperature | | | | | | | | | | | |
| | 65 °F | | 75 °F | | 85 °F | | 95 °F | | 105 °F | | 115 °F | |
| | Suct (psig) | Disc (psig) | Suct (psig) | Disc (psig) | Suct (psig) | Disc (psig) | Suct (psig) | Disc (psig) | Suct (psig) | Disc (psig) | Suct (psig) | Disc (psig) |
| Circuit 1 | 102 | 250 | 106 | 287 | 107 | 329 | 112 | 373 | 111 | 423 | 115 | 477 |
| | 108 | 253 | 111 | 291 | 114 | 333 | 118 | 380 | 122 | 431 | 123 | 486 |
| | 120 | 265 | 125 | 300 | 129 | 344 | 134 | 393 | 138 | 443 | 137 | 500 |
| | 134 | 280 | 138 | 318 | 144 | 362 | 148 | 410 | 153 | 462 | 155 | 517 |
| Circuit 2 | 94 | 248 | 97 | 283 | 98 | 323 | 103 | 370 | 108 | 412 | 110 | 453 |
| | 98 | 249 | 101 | 287 | 104 | 329 | 109 | 373 | 115 | 423 | 119 | 474 |
| | 112 | 260 | 117 | 297 | 120 | 341 | 124 | 386 | 129 | 435 | 135 | 487 |
| | 125 | 275 | 129 | 312 | 134 | 354 | 139 | 403 | 144 | 452 | 148 | 501 |

ZGA/ZGA092S4M (Staged) & ZGB/ZCB092S4B (CAV) Charging Curves

Outdoor Temperature (°F)

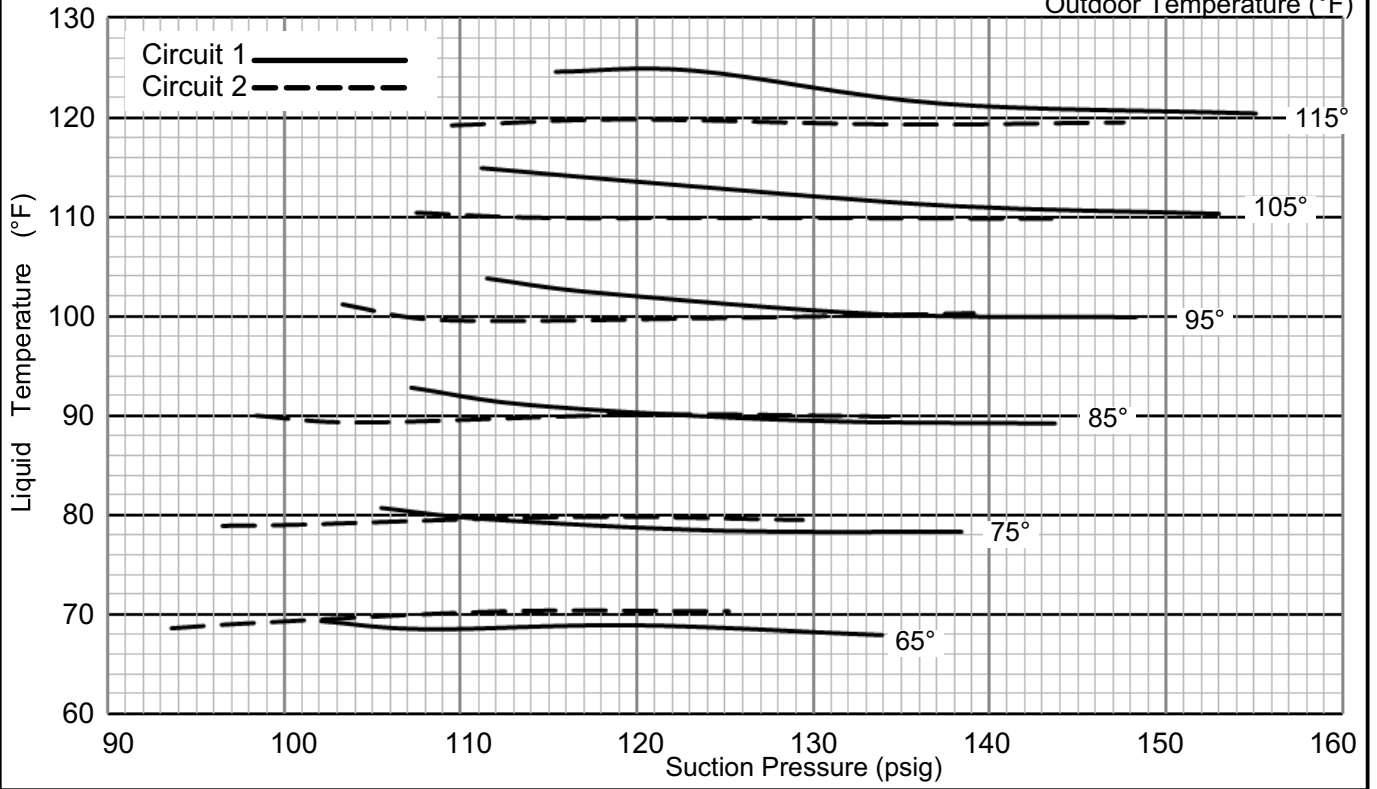

TABLE 6

| ZGA/ZCA102S4M (Staged) & ZGB/ZCB102S4B (CAV) Normal Operating Pressures | | | | | | | | | | | | |
|---|---------------------------------------|-------------|-------------|-------------|-------------|-------------|-------------|-------------|-------------|-------------|-------------|-------------|
| | Outdoor Coil Entering Air Temperature | | | | | | | | | | | |
| | 65 °F | | 75 °F | | 85 °F | | 95 °F | | 105 °F | | 115 °F | |
| | Suct (psig) | Disc (psig) | Suct (psig) | Disc (psig) | Suct (psig) | Disc (psig) | Suct (psig) | Disc (psig) | Suct (psig) | Disc (psig) | Suct (psig) | Disc (psig) |
| Circuit 1 | 108 | 250 | 110 | 284 | 113 | 328 | 116 | 371 | 119 | 423 | 123 | 478 |
| | 114 | 252 | 118 | 290 | 121 | 334 | 124 | 382 | 127 | 432 | 131 | 484 |
| | 128 | 267 | 132 | 305 | 137 | 347 | 140 | 392 | 145 | 445 | 148 | 500 |
| | 143 | 285 | 146 | 322 | 151 | 363 | 156 | 411 | 160 | 461 | 166 | 517 |
| Circuit 2 | 107 | 273 | 109 | 310 | 112 | 353 | 114 | 398 | 118 | 448 | 121 | 498 |
| | 114 | 277 | 117 | 315 | 120 | 357 | 123 | 403 | 125 | 447 | 129 | 496 |
| | 128 | 289 | 133 | 331 | 137 | 375 | 140 | 417 | 144 | 471 | 148 | 525 |
| | 144 | 303 | 148 | 344 | 153 | 391 | 157 | 438 | 162 | 489 | 166 | 545 |

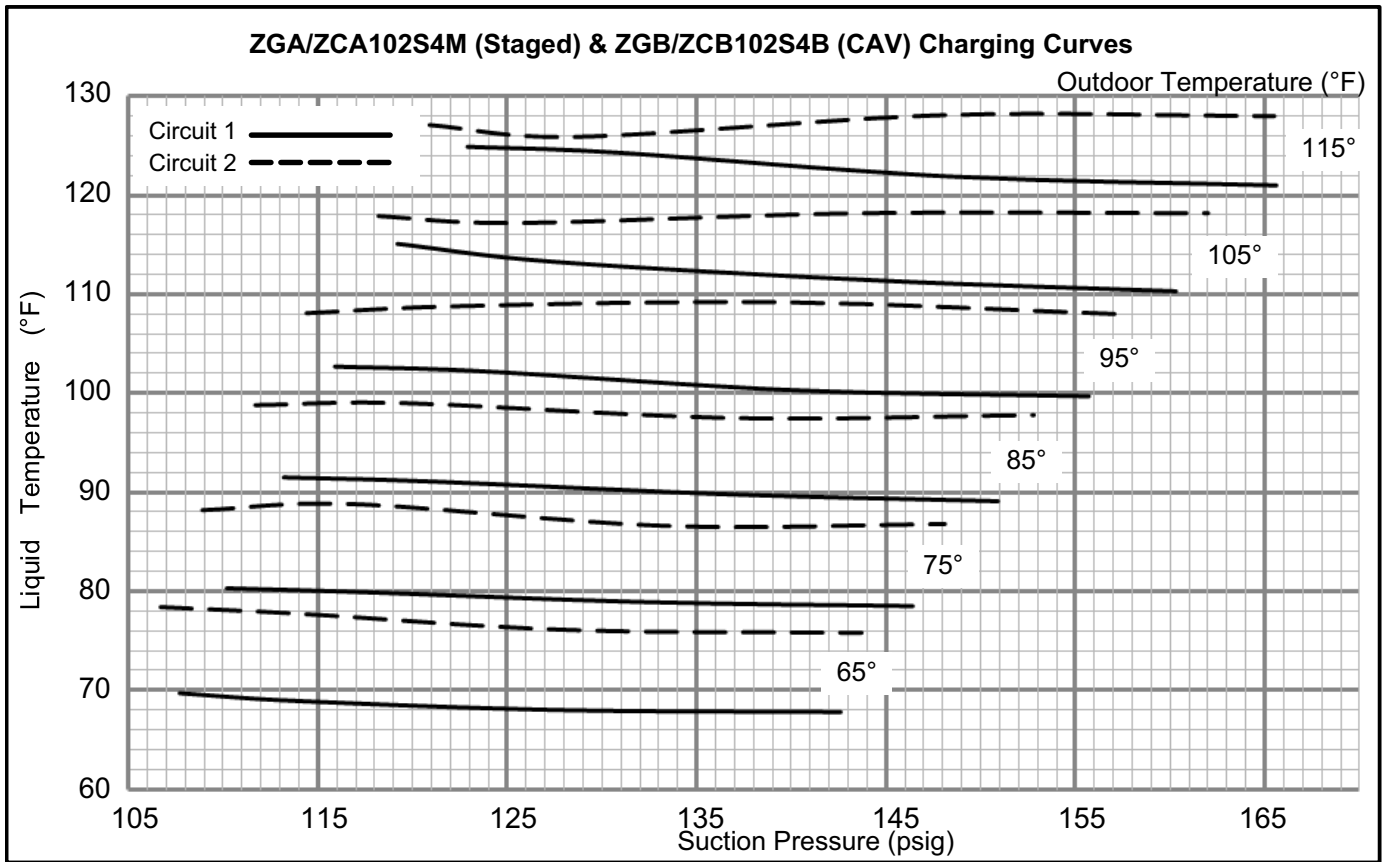

TABLE 7

ZGA/ZCA120S4M (Staged) Normal Operating Pressures

| | Outdoor Coil Entering Air Temperature | | | | | | | | | | | |
|-----------|---------------------------------------|-------------|-------------|-------------|-------------|-------------|-------------|-------------|-------------|-------------|-------------|-------------|
| | 65 °F | | 75 °F | | 85 °F | | 95 °F | | 105 °F | | 115 °F | |
| | Suct (psig) | Disc (psig) | Suct (psig) | Disc (psig) | Suct (psig) | Disc (psig) | Suct (psig) | Disc (psig) | Suct (psig) | Disc (psig) | Suct (psig) | Disc (psig) |
| Circuit 1 | 107 | 245 | 111 | 286 | 114 | 330 | 117 | 380 | 119 | 433 | 121 | 492 |
| | 113 | 249 | 117 | 252 | 121 | 333 | 125 | 382 | 128 | 440 | 129 | 501 |
| | 128 | 269 | 133 | 307 | 138 | 350 | 141 | 398 | 146 | 455 | 145 | 521 |
| | 140 | 284 | 145 | 321 | 151 | 363 | 157 | 413 | 162 | 470 | 163 | 539 |
| Circuit 2 | 110 | 254 | 114 | 296 | 117 | 342 | 120 | 391 | 121 | 444 | 126 | 507 |
| | 117 | 259 | 121 | 300 | 125 | 345 | 128 | 396 | 130 | 454 | 133 | 515 |
| | 133 | 281 | 138 | 321 | 142 | 365 | 145 | 414 | 149 | 472 | 151 | 537 |
| | 144 | 289 | 149 | 328 | 155 | 371 | 160 | 423 | 165 | 481 | 170 | 546 |

ZGA/ZCA120S4M (Staged) Charging Curves Outdoor Temperature (°F)

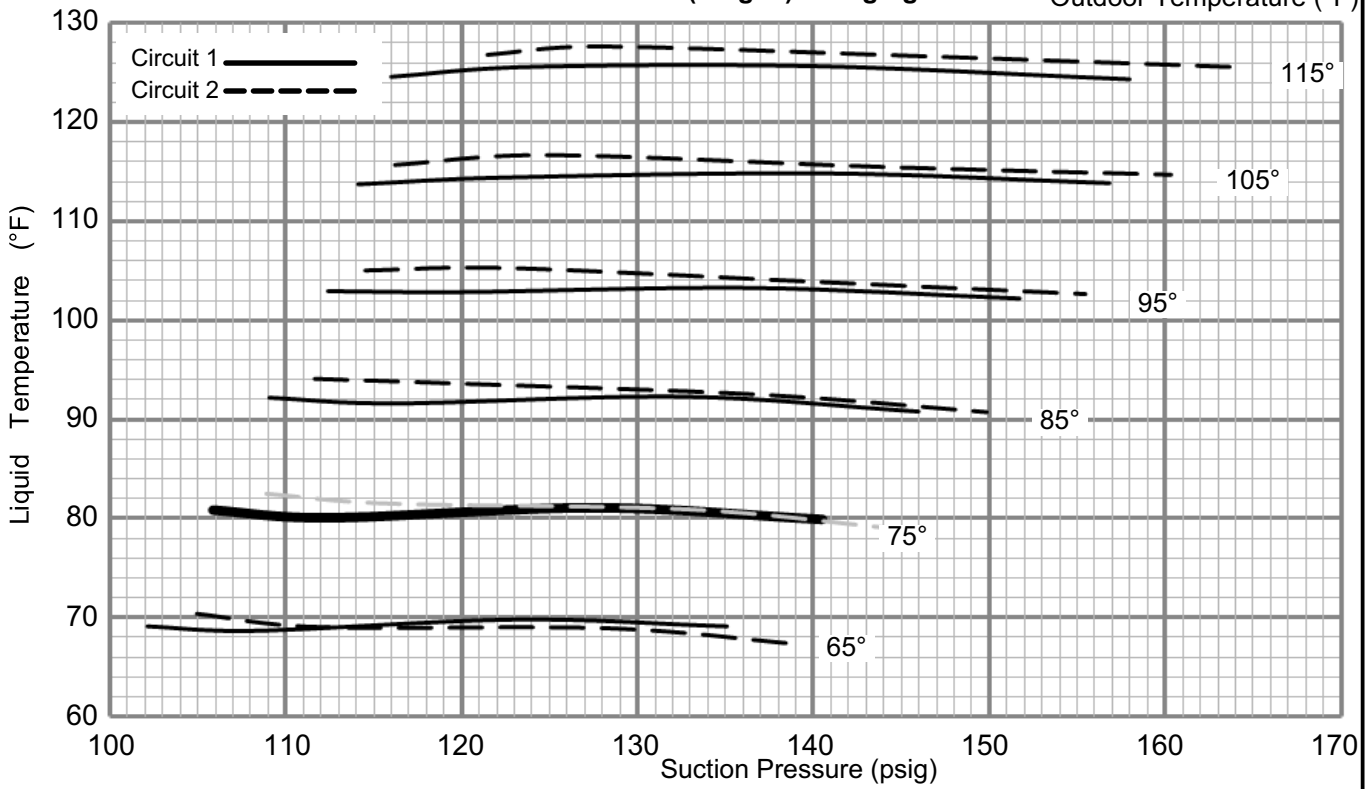

TABLE 8

ZGB/ZCB120S4B (CAV) Normal Operating Pressures

| | Outdoor Coil Entering Air Temperature | | | | | | | | | | | |
|-----------|---------------------------------------|-------------|-------------|-------------|-------------|-------------|-------------|-------------|-------------|-------------|-------------|-------------|
| | 65 °F | | 75 °F | | 85 °F | | 95 °F | | 105 °F | | 115 °F | |
| | Suct (psig) | Disc (psig) | Suct (psig) | Disc (psig) | Suct (psig) | Disc (psig) | Suct (psig) | Disc (psig) | Suct (psig) | Disc (psig) | Suct (psig) | Disc (psig) |
| Circuit 1 | 107 | 253 | 109 | 290 | 111 | 333 | 114 | 379 | 118 | 428 | 121 | 482 |
| | 115 | 260 | 117 | 297 | 120 | 340 | 124 | 386 | 127 | 436 | 130 | 490 |
| | 130 | 278 | 134 | 316 | 137 | 357 | 141 | 404 | 145 | 454 | 146 | 509 |
| | 146 | 302 | 152 | 341 | 155 | 383 | 159 | 430 | 164 | 482 | 167 | 537 |
| Circuit 2 | 107 | 262 | 109 | 301 | 112 | 344 | 115 | 390 | 119 | 440 | 121 | 494 |
| | 115 | 268 | 118 | 307 | 121 | 350 | 124 | 398 | 127 | 449 | 129 | 504 |
| | 128 | 275 | 133 | 320 | 137 | 363 | 141 | 412 | 144 | 462 | 146 | 521 |
| | 145 | 303 | 150 | 342 | 155 | 383 | 160 | 429 | 164 | 480 | 166 | 539 |

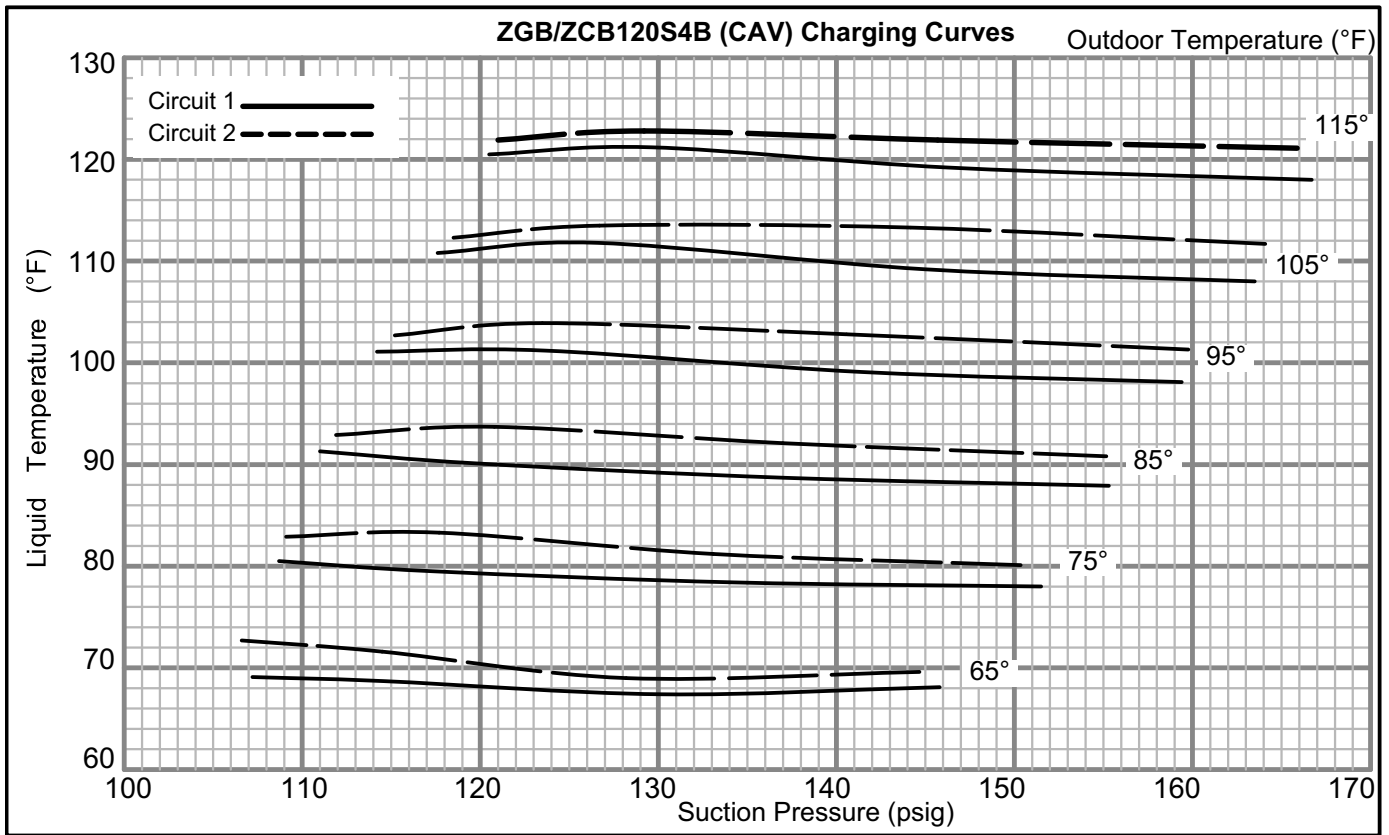

TABLE 9

ZGA/ZCA150S4M (Staged) Normal Operating Pressures

| | Outdoor Coil Entering Air Temperature | | | | | | | | | | | |
|-----------|---------------------------------------|-------------|-------------|-------------|-------------|-------------|-------------|-------------|-------------|-------------|-------------|-------------|
| | 65 °F | | 75 °F | | 85 °F | | 95 °F | | 105 °F | | 115 °F | |
| | Suct (psig) | Disc (psig) | Suct (psig) | Disc (psig) | Suct (psig) | Disc (psig) | Suct (psig) | Disc (psig) | Suct (psig) | Disc (psig) | Suct (psig) | Disc (psig) |
| Circuit 1 | 108 | 251 | 112 | 291 | 114 | 337 | 117 | 385 | 118 | 440 | 122 | 501 |
| | 114 | 254 | 118 | 293 | 122 | 338 | 124 | 385 | 127 | 440 | 129 | 496 |
| | 129 | 268 | 133 | 308 | 137 | 351 | 141 | 401 | 145 | 459 | 146 | 521 |
| | 144 | 290 | 148 | 326 | 154 | 373 | 159 | 423 | 163 | 479 | 167 | 538 |
| Circuit 2 | 110 | 258 | 113 | 298 | 116 | 344 | 118 | 390 | 122 | 448 | 125 | 507 |
| | 116 | 261 | 120 | 302 | 123 | 347 | 126 | 395 | 127 | 449 | 131 | 507 |
| | 130 | 275 | 134 | 315 | 138 | 360 | 142 | 410 | 147 | 467 | 149 | 526 |
| | 145 | 294 | 150 | 332 | 155 | 379 | 160 | 429 | 164 | 484 | 167 | 542 |

ZGA/ZCA150S4M (Staged) Charging Curves Outdoor Temperature (°F)

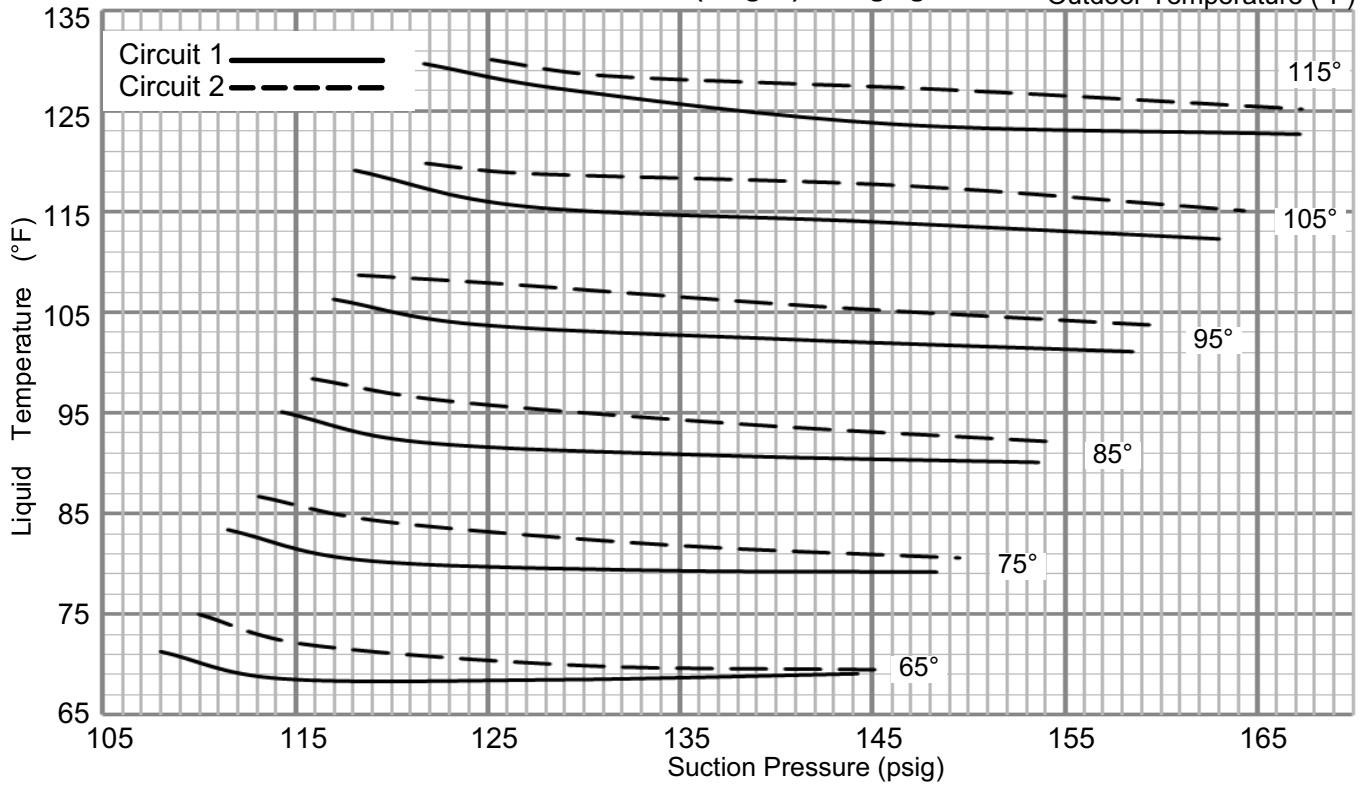
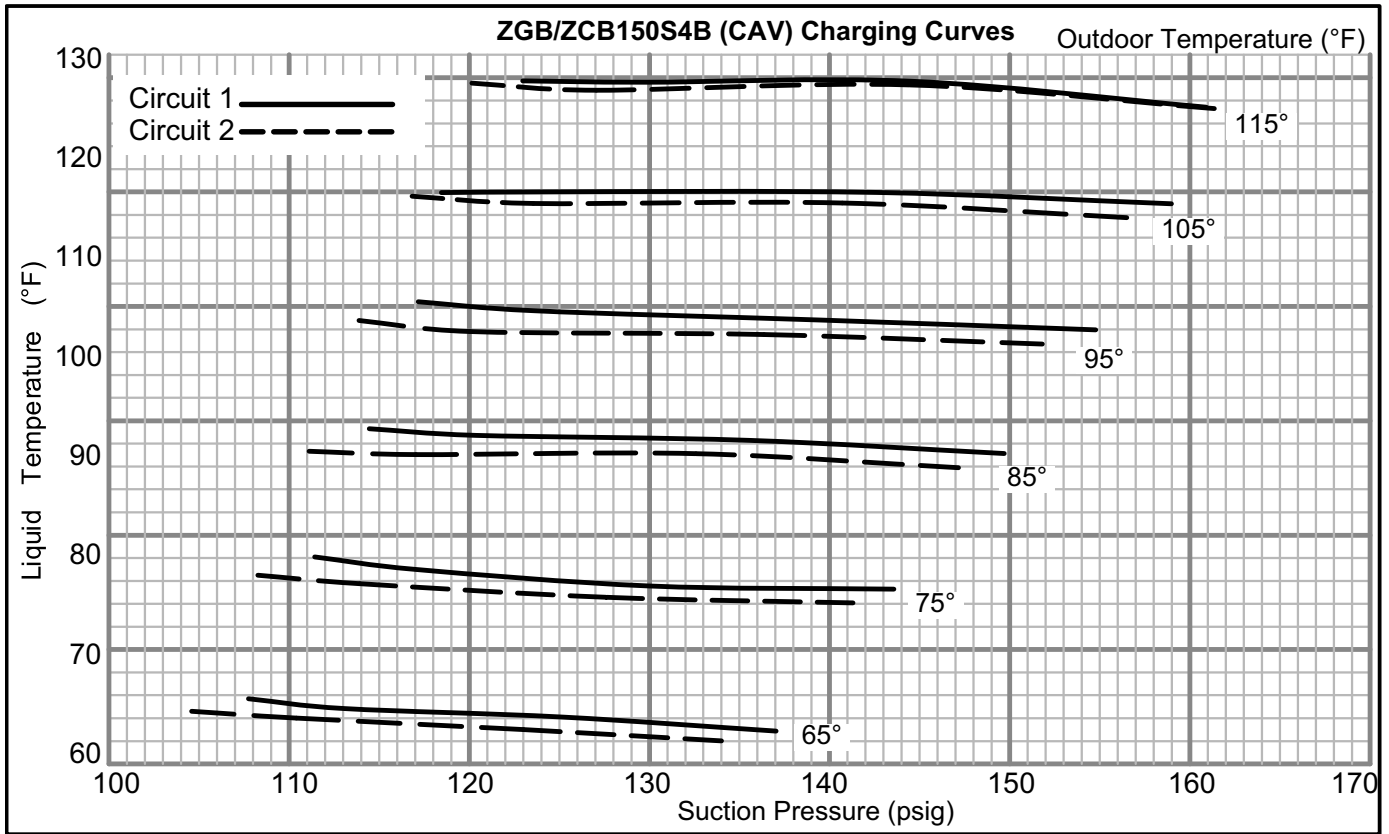

TABLE 10

ZGB/ZCB150S4B (CAV) Normal Operating Pressures

| | Outdoor Coil Entering Air Temperature | | | | | | | | | | | |
|-----------|---------------------------------------|-------------|-------------|-------------|-------------|-------------|-------------|-------------|-------------|-------------|-------------|-------------|
| | 65 °F | | 75 °F | | 85 °F | | 95 °F | | 105 °F | | 115 °F | |
| | Suct (psig) | Disc (psig) | Suct (psig) | Disc (psig) | Suct (psig) | Disc (psig) | Suct (psig) | Disc (psig) | Suct (psig) | Disc (psig) | Suct (psig) | Disc (psig) |
| Circuit 1 | 108 | 261 | 111 | 303 | 114 | 343 | 117 | 391 | 118 | 441 | 123 | 495 |
| | 113 | 264 | 117 | 305 | 120 | 349 | 124 | 394 | 124 | 443 | 130 | 498 |
| | 125 | 271 | 130 | 312 | 136 | 361 | 139 | 407 | 143 | 464 | 145 | 519 |
| | 137 | 277 | 144 | 322 | 150 | 370 | 155 | 418 | 159 | 471 | 161 | 524 |
| Circuit 2 | 105 | 261 | 108 | 304 | 111 | 344 | 114 | 392 | 117 | 442 | 120 | 495 |
| | 110 | 263 | 114 | 306 | 117 | 351 | 120 | 396 | 124 | 445 | 127 | 500 |
| | 123 | 270 | 128 | 312 | 133 | 361 | 136 | 409 | 141 | 465 | 144 | 520 |
| | 134 | 277 | 141 | 323 | 147 | 372 | 152 | 420 | 157 | 473 | 161 | 524 |



Gas Heat Start-Up (Gas Units)

FOR YOUR SAFETY READ BEFORE LIGHTING

⚠️ WARNING



Electric shock hazard. Can cause injury or death. Do not use this unit if any part has been under water. Immediately call a qualified service technician to inspect the unit and to replace any part of the control system and any gas control which has been under water.

⚠️ WARNING



Danger of explosion. Can cause injury or product or property damage. If overheating occurs or if gas supply fails to shut off, shut off the manual gas valve to the appliance before shutting off electrical supply.

⚠️ WARNING



Electric shock hazard. Can cause injury or death. Before attempting to perform any service or maintenance, turn the electrical power to unit OFF at disconnect switch(es). Unit may have multiple power supplies.

⚠️ WARNING

SMOKE POTENTIAL

The heat exchanger in this unit could be a source of smoke on initial firing. Take precautions with respect to building occupants and property. Vent initial supply air outside when possible.

BEFORE LIGHTING smell all around the appliance area for gas. Be sure to smell next to the floor because some gas is heavier than air and will settle on the floor.

Use only your hand to push in or turn the gas control knob. Never use tools. If the knob will not push in or turn by hand, do not try to repair it, call a qualified service technician. Force or attempted repair may result in a fire or explosion.

⚠️ WARNING



Danger of explosion. Can cause injury or death. Do not attempt to light manually. Unit has a direct spark ignition system.

This unit is equipped with an automatic spark ignition system. There is no pilot. In case of a safety shutdown, move thermostat switch to **OFF** and return the thermostat switch to **HEAT** to reset ignition control.

A-Placing Unit In Operation

⚠️ WARNING



Danger of explosion and fire. Can cause injury or product or property damage. You must follow these instructions exactly.

Gas Valve Operation for Honeywell VR8305Q or White Rodgers 36H54 (figure 17 or 18)

- 1- Set thermostat to lowest setting.
- 2- Turn off all electrical power to appliance.
- 3- This appliance is equipped with an ignition device which automatically lights the burner. Do **not** try to light the burner by hand.
- 4- Open or remove the heat section access panel.

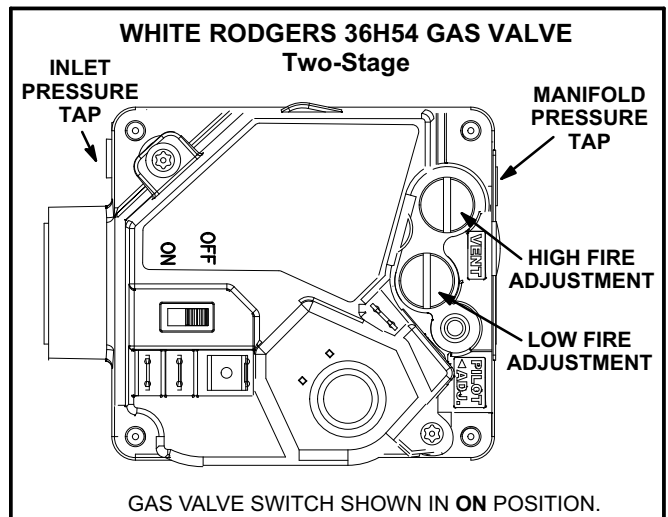

FIGURE 17

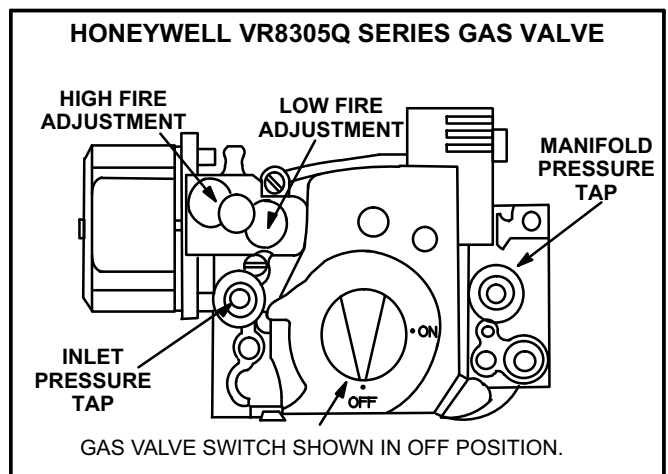





FIGURE 18

- 5- Turn gas valve switch to **OFF**. See figure 17. On Honeywell VR8305Q gas valves, turn the knob on the gas valve clockwise  to “**OFF**”. Do not force. See figure 18.
- 6- Wait five (5) minutes to clear out any gas. If you then smell gas, **STOP!** Immediately call your gas supplier from a neighbor's phone. Follow the gas supplier's instructions. If you do not smell gas, go to the next step.
- 7- Turn gas valve switch to **ON**. See figure 17. On Honeywell VR8305Q gas valves, turn the knob on the gas valve counterclockwise  to “**ON**”. Do not force. See figure 18.
- 8- Close or replace the heat section access panel.
- 9- Turn on all electrical power to appliance.
- 10- Set thermostat to desired setting.
- 11- The ignition sequence will start.
- 12- If the appliance does not light the first time (gas line not fully purged), it will attempt up to two more ignitions before locking out.
- 13- If lockout occurs, repeat steps 1 through 10.
- 14- If the appliance will not operate, follow the instructions “Turning Off Gas to Appliance” and call your service technician or gas supplier.

Turning Off Gas to Unit

- 1- If using an electromechanical thermostat, set to the lowest setting.
- 2- Before performing any service, turn off all electrical power to the appliance.
- 3- Open or remove the heat section access panel.
- 4- Turn gas valve switch to **OFF**. On Honeywell VR8305Q gas valves, turn the knob on the gas valve clockwise  to “**OFF**”. Do not force.
- 5- Close or replace the heat section access panel.

| | |
|---|---|
| ⚠ WARNING | |
|  | Danger of explosion. Can cause injury or death. Do not attempt to light manually. Unit has a direct spark ignition system. |

Heating Operation and Adjustments

(Gas Units)

A-Heating Sequence of Operation

- 1- On a heating demand the combustion air inducer starts immediately.
- 2- Combustion air pressure switch proves inducer operation. After a 30-second pre-purge, power is

allowed to ignition control. Switch is factory set and requires no adjustment.

- 3- Spark ignitor energizes and gas valve solenoid opens.
- 4- Spark ignites gas, ignition sensor proves the flame and combustion continues.
- 5- If flame is not detected after first ignition trial, ignition control will repeat steps 3 and 4 two more times before locking out the gas valve.
- 6- For troubleshooting purposes, an ignition attempt after lock out may be re-established manually. Move thermostat to “OFF” and return thermostat switch to “HEAT” position.

B-Ignition Control Diagnostic LED's

**TABLE 11
IGNITION CONTROL HEARTBEAT LED STATUS**

| LED Flashes | Indicates |
|-------------|---|
| Slow | Normal operation. No call for heat. |
| Fast | Normal operation. Call for heat. |
| Steady Off | Internal control fault OR no power to control OR Gas Valve Relay Fault. |
| Steady On | Control internal failure. |
| 2 | Lockout. Failed to detect or sustain flame. |
| 3 | Prove switch open or closed or rollout switch open. |
| 4 | Limit switch is open and/or limit has opened three times. |
| 5 | Flame sensed but gas valve solenoid not energized. |

C-Limit Controls

Limit controls are factory-set and are not adjustable. The primary limit is located on the bottom right of the control box.

D-Heating Adjustment

Main burners are factory-set and do not require adjustment.

The following manifold pressures are listed on the gas valve.

- Natural Gas Units - Low Fire - 1.6” w.c. (not adjustable)
- Natural Gas Units - High Fire - 3.7” w.c.
- LP Gas Units - Low Fire - 5.5” w.c. (not adjustable)
- LP Gas Units - High Fire - 10.5” w.c.

Electric Heat Start-Up (ZCA Units)

Optional electric heat will stage on and cycle with thermostat demand. Number of stages of electric heat will vary depending on electric heat assembly. See electric heat wiring diagram on unit for sequence of operation.

Service

The unit should be inspected once a year by a qualified service technician.

⚠ CAUTION

Label all wires prior to disconnection when servicing controls. Wiring errors can cause improper and dangerous operation. Verify proper operation after servicing.

A-Filters

Units are equipped with 20 X 24 X 2" temporary filters which must be replaced prior to building occupation. Refer to local codes or appropriate jurisdiction for approved filters.

To change filters, open filter access panel on back side of unit. See figure 19. Lift filter stop to remove filters. See figure 20.

⚠ WARNING

Units are shipped from the factory with temporary filters. Replace filters before building is occupied. Damage to unit could result if filters are not replaced with approved filters. Refer to appropriate codes.

Approved filters should be checked monthly and replaced when necessary. Take note of air flow direction marking on filter frame when reinstalling filters. See figure 20.

NOTE-Filters must be U.L.C. certified or equivalent for use in Canada.

B-Lubrication

All motors are lubricated at the factory. No further lubrication is required.

C-Burners (Gas Units)

Periodically examine burner flames for proper appearance during the heating season. Before each heating season examine the burners for any deposits or blockage which may have occurred.

Clean burners as follows:

- 1- Turn off both electrical power and gas supply to unit.
- 2- Remove burner compartment access panel.

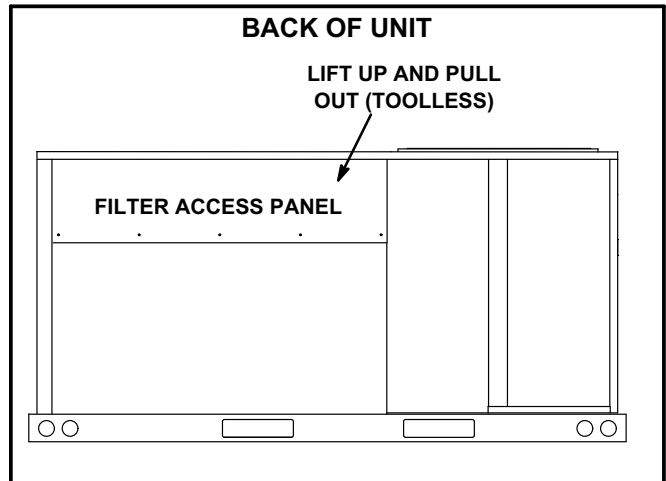

FIGURE 19

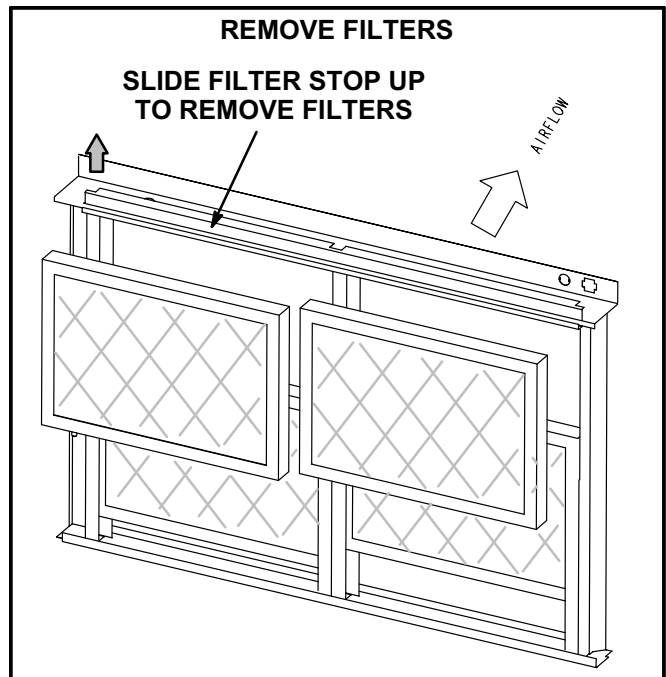

FIGURE 20

- 3- Remove screws securing burners to burner support and lift the individual burners or entire burner assembly from the orifices. See figure 21. Clean as necessary.
- 4- Locate the ignitor under the left burners. Check ignitor spark gap with appropriately sized twist drills or feeler gauges. See figure 22.

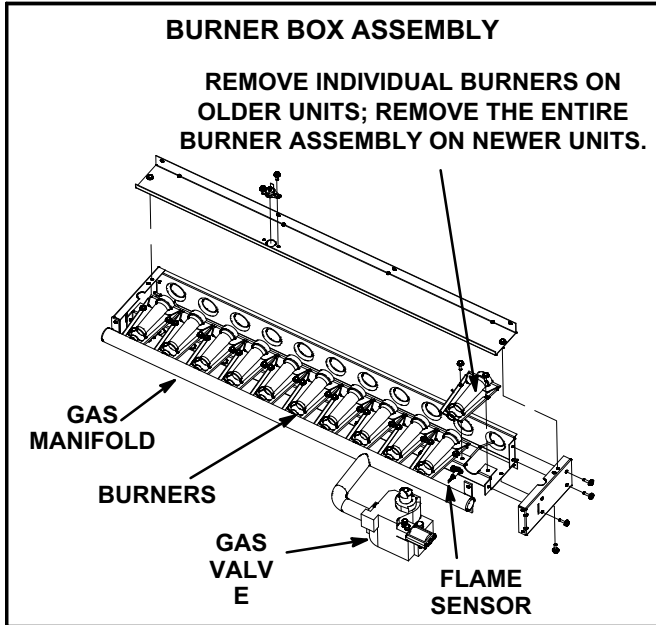

FIGURE 21

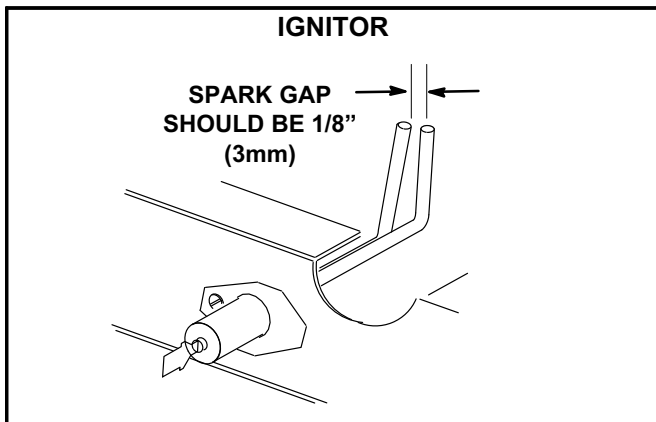

FIGURE 22

- 5- Check the alignment of the ignitor and the sensor as shown in figure 23 and table 12.
- 6- Replace burners and screws securing burner.

⚠ WARNING

Danger of explosion. Can cause injury or death. Do not overtighten main burner mounting screws. Snug tighten only.

TABLE 12

| Dimension | Unit Btuh Input | Length - in. (mm) | |
|-----------|--------------------|-------------------|-------------|
| | | Ignitor | Sensor |
| A | 130K | 7-3/4 (197) | 11 (279) |
| B | 180K | 5 (127) | 5-1/2 (140) |
| C | 240K | 2-1/4 (57) | 2-3/4 (70) |

- 7- Replace access panel.
- 8- Restore electrical power and gas supply. Follow lighting instructions attached to unit and use inspection port in access panel to check flame.

D-Combustion Air Inducer (Gas Units)

A combustion air proving switch checks combustion air inducer operation before allowing power to the gas controller. Gas controller will not operate if inducer is obstructed.

Under normal operating conditions, the combustion air inducer wheel should be checked and cleaned prior to the heating season. However, it should be examined periodically during the heating season to establish an ideal cleaning schedule. With power supply disconnected, the condition of the inducer wheel can be determined by looking through the vent opening.

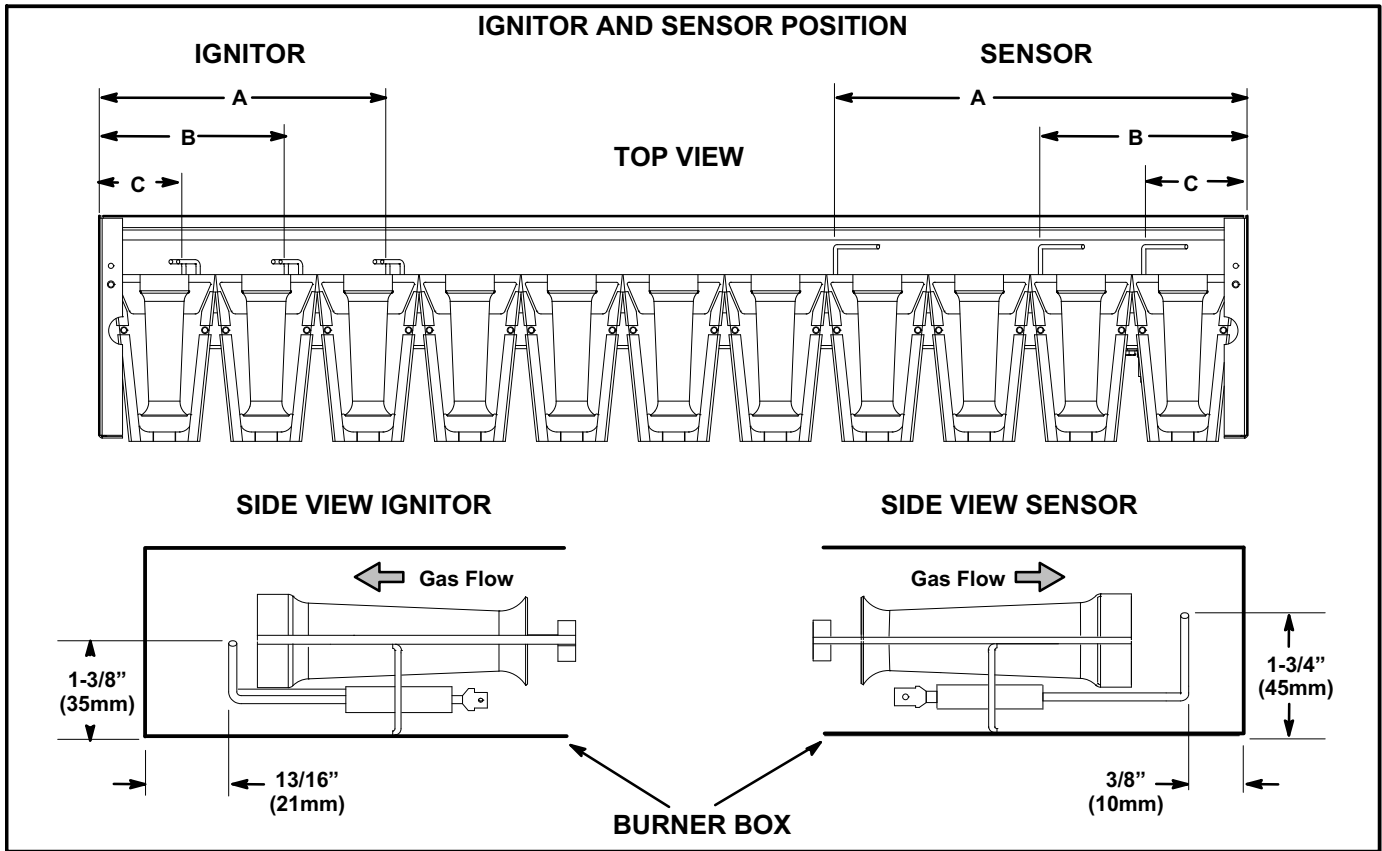

FIGURE 23

Clean combustion air inducer as follows:

- 1- Shut off power supply and gas to unit.
- 2- Disconnect pressure switch air tubing from combustion air inducer port.
- 3- Remove and retain screws securing combustion air inducer to flue box. Remove vent connector. See figure 24.

- 4- Clean inducer wheel blades with a small brush and wipe off any dust from housing. Clean accumulated dust from front of flue box cover.
- 5- Return combustion air inducer motor and vent connector to original location and secure with retained screws. It is recommended that the combustion air inducer gasket be replaced during reassembly.
- 6- Clean combustion air inlet louvers on heat access panel using a small brush.

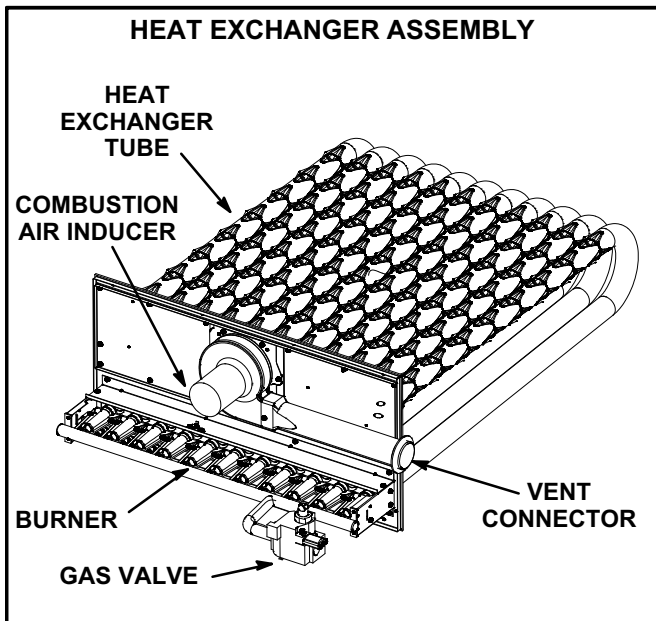

FIGURE 24

E-Flue Passageway and Flue Box (Gas Units)

- 1- Remove combustion air inducer assembly as described in section D.
- 2- Remove flue box cover. Clean with a wire brush as required.
- 3- Clean tubes with a wire brush.
- 4- Reassemble the unit. The flue box cover gasket and combustion air inducer gasket should also be replaced during reassembly.

F-Evaporator Coil

Inspect and clean coil at beginning of each cooling season. Clean using mild detergent or commercial coil cleaner. Flush coil and condensate drain with water taking care not to get insulation, filters and return air ducts wet.

G-Supply Air Blower Wheel

Annually inspect supply air blower wheel for accumulated dirt or dust. Turn off power before attempting to remove access panel or to clean blower wheel.

H-Condenser Coil

Clean condenser coil annually with water and inspect monthly during the cooling season.

Clean the all-aluminum coil by spraying the coil steadily and uniformly from top to bottom. Do not exceed 900 psi or a 45° angle; nozzle must be at least 12 inches from the coil face. Take care not to fracture the braze between the fins and refrigerant tubes. Reduce pressure and work cautiously to prevent damage.