

See unit nameplate for manufacturer and address.  
©2021

# INSTALLATION INSTRUCTIONS

AGENCY REQUIRED

**RETAIN THESE INSTRUCTIONS FOR FUTURE REFERENCE**



**PACKAGED GAS UNITS**  
507259-04  
8/2021  
Supersedes 5/2019

## ZG 036-150 UNITS

3 THROUGH 12-1/2 TONS

### Table of Contents

Safety .....	1
Connect Gas Piping .....	3
High Altitude Derate .....	3
Pressure Test Gas Piping .....	4
Two Stage Gas Valve Adjustment .....	4
Gas Heat Operation .....	4
Proper Gas Flow .....	4
Typical Gas Heat Schematic .....	5
Typical Unit Schematic .....	6
Repair Parts Listing .....	8

### Safety

## ⚠ WARNING

**Improper installation, adjustment, alteration, service or maintenance can cause property damage, personal injury or loss of life. Installation and service must be performed by a licensed professional HVAC installer or equivalent, service agency, or the gas supplier**

Use of this unit as a construction heater or air conditioner is not recommended during any phase of construction. Very low return air temperatures, harmful vapors and operation of the unit with clogged or misplaced filters will damage the unit.

If this unit has been used for heating or cooling of buildings or structures under construction, the following conditions must be met or the warranty will be void:

- The vent hood must be installed per these installation instructions.
- A room thermostat must control the unit. The use of fixed jumpers that will provide continuous heating or cooling is not allowed.
- A pre-filter must be installed at the entry to the return air duct.
- The return air duct must be provided and sealed to the unit.

- Return air temperature range between 55°F (13°C) and 80°F (27°C) must be maintained.
- Air filters must be replaced and pre-filter must be removed upon construction completion.
- The input rate and temperature rise must be set per the unit rating plate.
- The heat exchanger, components, duct system, air filters and evaporator coil must be thoroughly cleaned following final construction clean-up.
- The unit operating conditions (including airflow, cooling operation, ignition, input rate, temperature rise and venting) must be verified according to these installation instructions.

**NOTE - The Commonwealth of Massachusetts stipulates these additional requirements:**

- **Gas units shall be installed by a licensed plumber or gas fitter only.**
- **The gas cock must be “T handle” type.**

The unit is certified for installation on noncombustible floors only. However, it may be installed on wood flooring, or on class A, class B, or class C material covered floors when used in horizontal discharge applications or in downflow discharge applications when mounted on an Z1CURB roof mounting frame.

Adequate clearance shall be provided around air openings into the vestibule area. Provisions shall be made for proper operation and for combustion air and ventilation air supply. Unit must be adjusted for the temperature rise range and within the allowable external static pressure on furnaces with a duct system as listed on unit nameplate.



**United States**

The units outlined in this manual are ETL/CSA certified for outdoor installations only at the clearances to combustible materials listed on the unit nameplate and in figures 1 or 2.

Installation of the ETL/CSA certified units must conform with local building codes. In the absence of local codes, units must be installed according to the current National Fuel Gas Code ANSI Z223.1/NFPA 54.

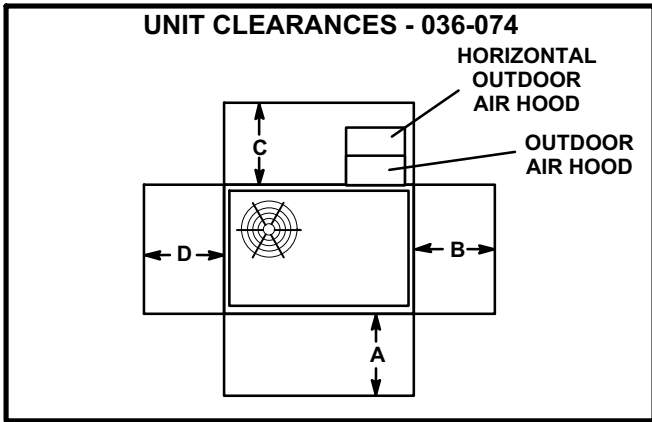
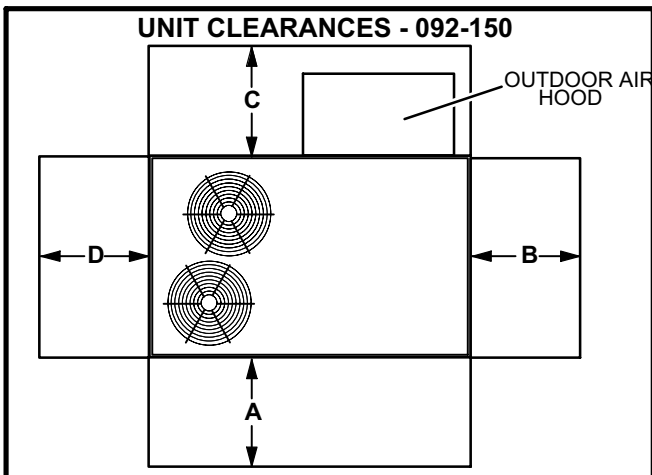

**FIGURE 1**

<sup>1</sup> Unit Clearance	A in.(mm)	B in.(mm)	C in.(mm)	D in.(mm)	Top Clearance
Service Clearance	36 (914)	36 (914)	36* (914)	36 (914)	Unobstructed
Clearance to Combustibles	36 (914)	1 (25)	1 (25)	1 (25)	Unobstructed
Minimum Operation Clearance	36 (914)	36 (914)	36* (914)	36 (914)	Unobstructed

\*Clearance is 60 in. (1524mm) in horizontal air flow applications.  
 Note - Entire perimeter of unit base requires support when elevated above mounting surface.

<sup>1</sup> **Service Clearance** - Required for removal of serviceable parts.  
**Clearance to Combustibles** - Required clearance to combustible material (gas units).  
**Minimum Operation Clearance** - Required clearance for proper unit operation.



**FIGURE 2**

<sup>1</sup> Unit Clearance	A in.(mm)	B in.(mm)	C in.(mm)	D in.(mm)	Top Clearance
Service Clearance	36 (914)	36 (914)	60 (1524)	36 (914)	Unobstructed
Clearance to Combustibles*	36 (914)	1 (25)	1 (25)	1 (25)	Unobstructed
Minimum Operation Clearance	36 (914)	36 (914)	60 (1524)	36 (914)	Unobstructed

Note - Entire perimeter of unit base requires support when elevated above mounting surface.

<sup>1</sup> **Service Clearance** - Required for removal of serviceable parts.  
**Clearance to Combustibles\*** - Required clearance to combustible material.  
**Minimum Operation Clearance** - Required clearance for proper unit operation.

\*Gas units.

When installed, the unit must be electrically wired and grounded according to local codes or, in the absence of local codes, with the current National Electric Code, ANSI/NFPA 70.

The current American National Standard (ANSI-Z223.1/NFPA54) National Fuel Gas Code is available from the following address:

American National Standard Institute Inc.  
 11 West 42nd Street  
 New York, NY 10036

The current National Electric Code (ANSI/NFPA 70) is available from the following address:

National Fire Protection Association  
 1 Batterymarch Park  
 PO Box 9101  
 Quincy, MA 02269-9101

Use only the type of gas approved for use with this furnace. Refer to unit nameplate.

Never test for gas leaks with an open flame. Check all connections with a commercially available soap solution made specifically for leak detection.

*NOTE - Furnace must be adjusted to obtain a temperature rise (high and low fire) within the range(s) specified on the unit nameplate. Failure to do so may cause erratic limit operation.*

**Canada**

The units outlined in this manual are ETL/CSA certified for combination heating/cooling for outdoor installations and non-residential use only at the clearances to combustible materials as listed on the unit nameplate.

Installation of ETL/CSA certified units must conform with current standard CSA B149.1, "Natural Gas and Propane Installation Codes" and applicable local codes. Authorities having jurisdiction should be consulted before installation.

The unit must be wired and electrically grounded according to local codes or, in the absence of local codes, current CSA Standard C22.1 Canadian Electrical Code Part 1. Installation of combination heating/cooling units must also conform with current CSA Standard B52 "Mechanical Refrigeration Code."

**Connect Gas Piping**

A manual main shut-off valve must be installed external to the unit when local codes require the installation of such a valve.

Install a ground joint union between the gas control manifold and the main manual shut-off valve.

When making piping connections a drip leg should be installed on vertical pipe runs to serve as a trap for sediment or condensate.

A 1/8" N.P.T. plugged tap is located on gas valve for test gauge connection. See figure 3, 4, 5 or 6 for tap location. See figure 7 for for gas supply piping entry through the side of the unit.

Compounds used on threaded joints of gas piping must be resistant to the actions of liquified petroleum gases.

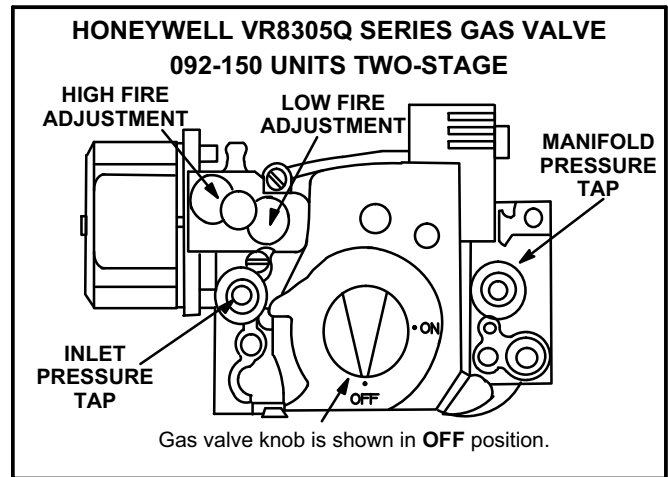

**FIGURE 5**

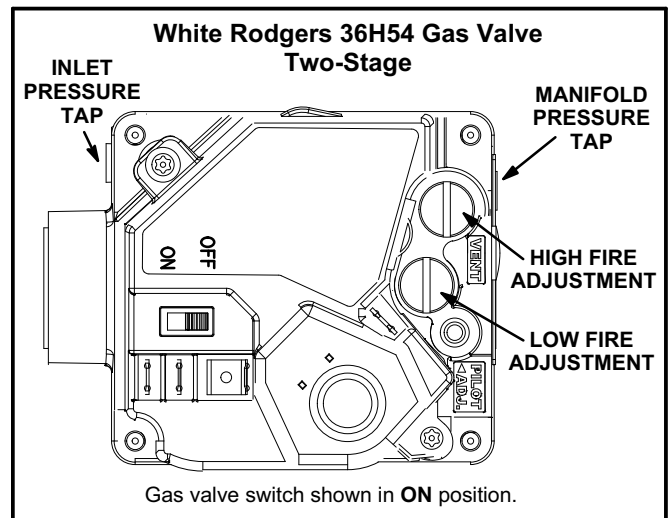

**FIGURE 6**

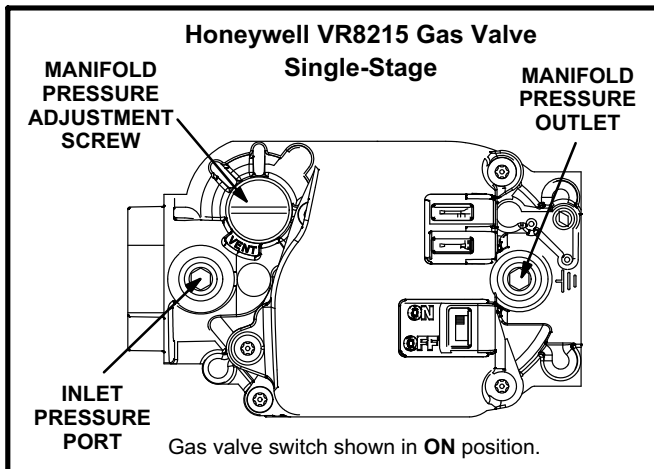

**FIGURE 3**

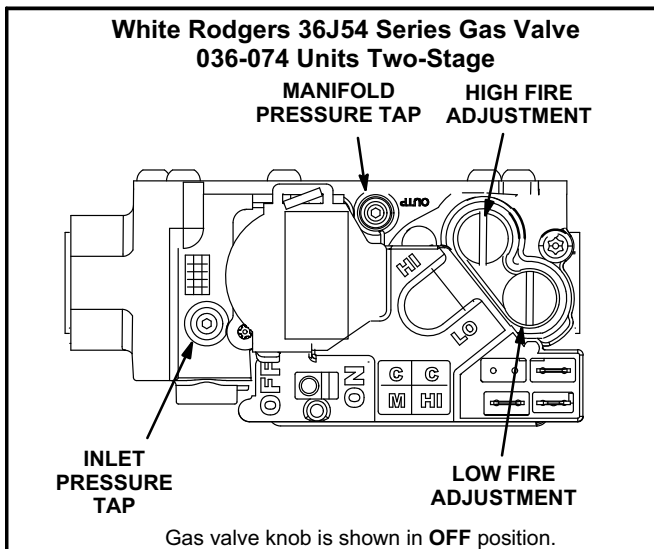

**FIGURE 4**

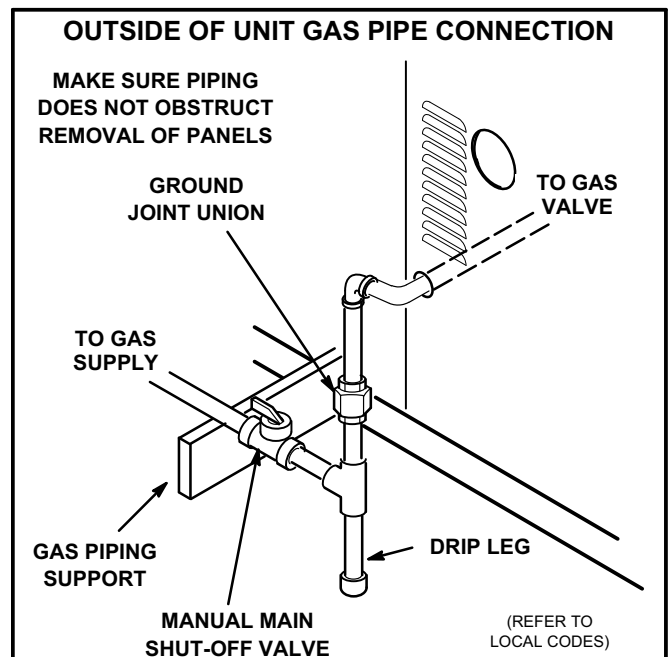

**FIGURE 7**

## High Altitude Derate

Locate the high altitude conversion sticker in the unit literature bag. Fill out the conversion sticker and affix next to the unit nameplate.

Refer to table 1 for high altitude adjustments.

**TABLE 1  
HIGH ALTITUDE DERATE**

Altitude Ft.*	Gas Manifold Pressure
2000-4500	See Unit Nameplate
4500 And Above	Derate 2% / 1000 Ft. Above Sea Level

\*Units installed at 0-2000 feet do not need to be modified.

*NOTE - This is the only permissible derate for these units.*

## Pressure Test Gas Piping

Operating pressures at the unit gas connection must be as shown in table 2.

**TABLE 2  
OPERATING PRESSURE AT GAS CONNECTION  
"w.c."**

	Natural Gas		LP / Propane Gas	
	Min.	Max.	Min.	Max.
036, 048, 060, 072, 074	4.5	10.5	11	13
092-150	4.5	10.5	11	13

When testing the pressure of gas lines, the gas valve must be disconnected and isolated. Gas valves can be damaged if subjected to more than 0.5 psig.

## **⚠ WARNING**

### **FIRE OR EXPLOSION HAZARD**

**Failure to follow the safety warnings exactly could result in serious injury, death or property damage.**

**Never test for gas leaks with an open flame. Use a commercially available soap solution made specifically for the detection of leaks to check all connections. A fire or explosion may result causing property damage, personal injury or loss of life.**

## Two-Stage Gas Valve Adjustment

Gas manifold pressures are listed on the gas valve and in table 3.

On two stage gas valves, initiate a W2 thermostat demand to check high fire pressure before low fire pressure. With high fire operating, reduce the thermostat demand to W1 and check the low fire pressure.

**IMPORTANT - Do not set low fire pressure lower than the certified minimum input rating listed above.**

**TABLE 3  
MANIFOLD PRESSURES in.wg. (kPa)**

Unit	Natural Gas		Propane (LP) Gas	
	1st Stage ± 0.2	2nd Stage ± 0.3	1st Stage ± 0.2	2nd Stage ± 0.3
036, 048, 060, 072, 074	2.0	3.5	5.9	10.5
092-150	1.6	3.7	5.5	10.5

## Gas Heat Operation

See the operating instruction plate on the unit for details.

## Proper Gas Flow (Approximate)

- 1- Operate unit at least 15 minutes before checking gas flow. Determine the time in seconds for **two** revolutions of gas through the meter. (Two revolutions assures a more accurate time.) A portable LP gas meter (17Y44) is available for LP applications.
- 2- **Divide the number of seconds by two** and compare to the time in table 4. If manifold pressure is correct and rate is incorrect, check gas orifices for proper size and restriction.
- 3- Remove temporary gas meter if installed.

*NOTE- To obtain accurate reading, shut off all other gas appliances connected to meter.*

**TABLE 4  
GAS METER CLOCKING CHART**

Unit Input Rate (Btuh)	Seconds for One Revolution			
	Natural		LP	
	1 cu ft Dial	2 cu ft Dial	1 cu ft Dial	2 cu ft Dial
65,000	55	111	138	277
108,000	33	67	83	167
130,000	28	55	69	138
150,000	24	48	60	120
169,000	21	43	53	107
180,000	20	40	50	100
240,000	15	30	38	75
260,000	14	28	35	69
360,000	10	20	30	50
480,000	8	15	19	38
Natural-1000 btu/cu ft		LP-2500 btu/cu ft		

*Note: Table assumes standard temperature (60°F), pressure (30in.Hg.), and fuel heating values (Btuh/Ft.<sup>3</sup>). Apply pressure corrections in altitudes above 2000 ft.*

# TYPICAL GAS HEAT SCHEMATIC

This schematic is typical. See the wiring schematic on the unit for actual unit wiring.

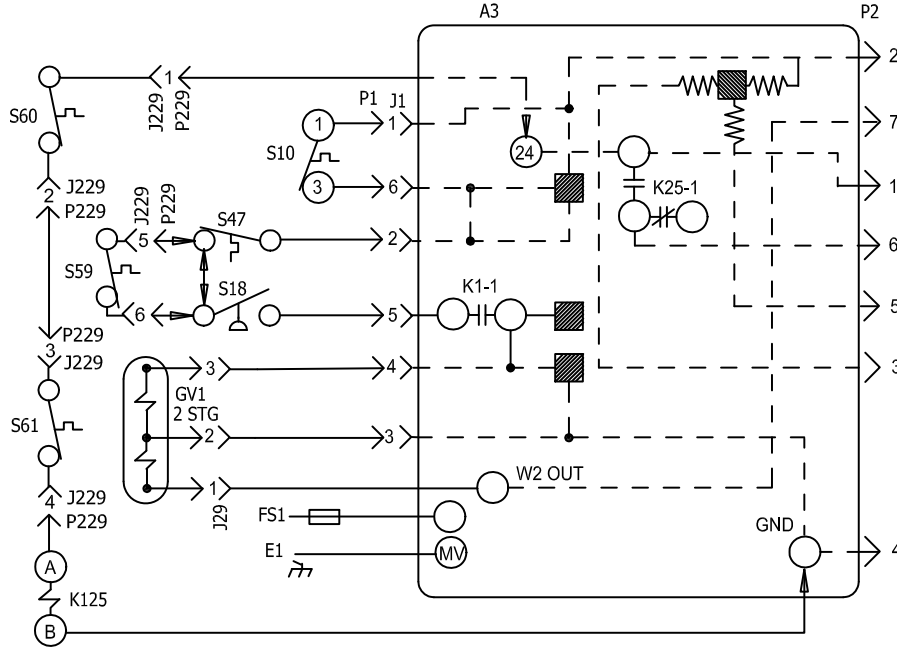

- INDICATES MICRO PROCESSOR
- DENOTES OPTIONAL COMPONENTS
- CSA(-50C) LOW AMBIENT KIT (OPTIONAL)
- T3 USED ON 480V AND 600V UNITS

KEY	COMPONENT
A3	CONTROL-BURNER 1
B6	MOTOR-COMBUSTION AIR BLOWER 1
C3	CAPACITOR-COMB AIR BLOWER, MOTOR 1
E1	IGNITOR-SPARK
FS1	SENSOR-FLAME
GV1	VALVE-GAS 1
HR6	HEATER, -50C LOW AMBIENT KIT
J29	JACK-GAS 1
K125,-1	RELAY-HEAT SHUTOFF
P2	PLUG-HEAT
S10	SWITCH-LIMIT, PRIMARY GAS
S18	SWITCH-COMB AIR BLOWER, PROVE
S47	SWITCH-FLAME ROLLOUT, BURNER 1
S59	THERMOSTAT-OPEN -20F, CLOSE 10F
S60	THERMOSTAT-OPEN 20F, CLOSE -10F
S61	THERMOSTAT-OPEN 50F, CLOSE 20F
T3	TRANSFORMER-COMB AIR BLOWER 1

J/P	JACK/PLUG DESCRIPTION
1	GAS LIMIT
19	COMBUSTION AIR BLOWER
229	VESTIBULE HEATER, CONTROL 1

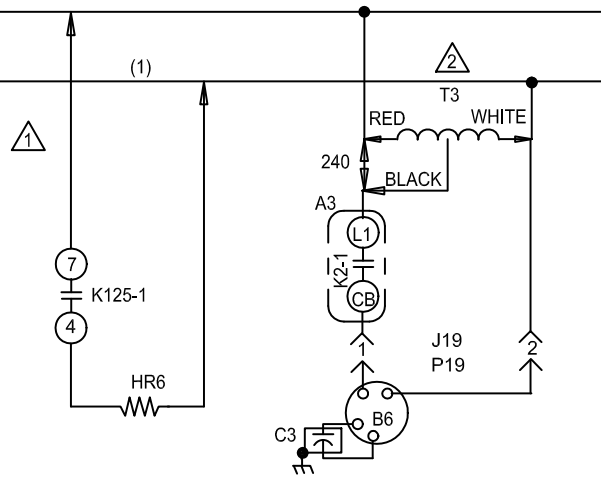

11/13		<b>WIRING DIAGRAM</b>  537063-02	11/13
<b>HEATING - GAS</b>			
<b>ZG UNITS - 130 THRU 240</b>			
<b>SECTION A</b>			<b>REV 1</b>
Supersedes 537063-01		New Form No. 537063-02	

# TYPICAL TWO-SPEED BLOWER SCHEMATIC

This schematic is typical. See the wiring schematic on the unit for actual unit wiring.

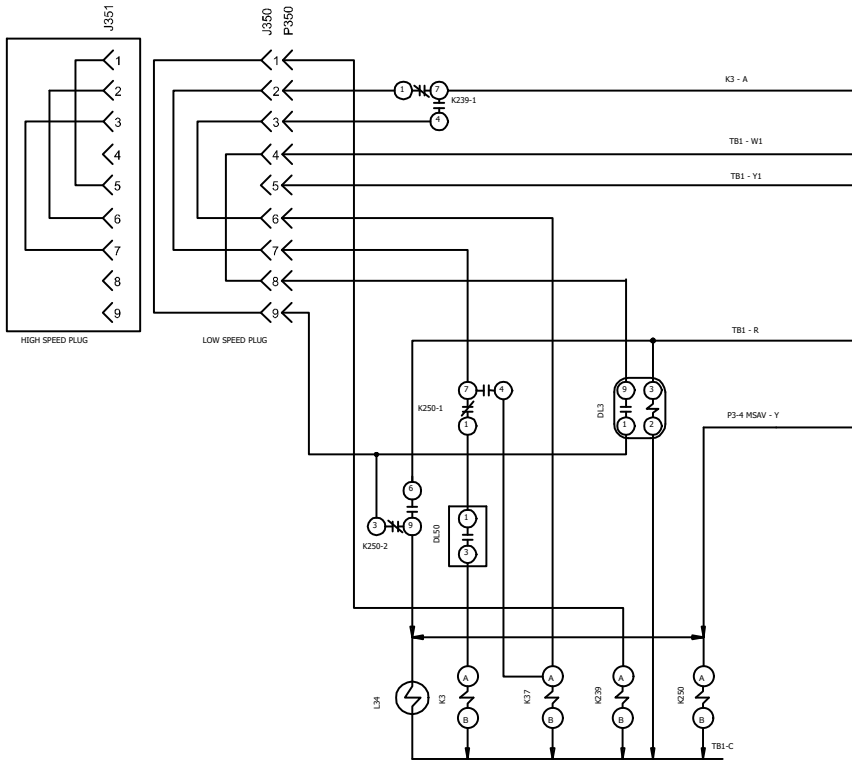

J / P	JACK / PLUG DESCRIPTION
350	BLOWER HI/LO MECHANICAL SWITCHING
351	BLOWER HI/LO MECHANICAL SWITCHING

KEY	COMPONENT
B3	MOTOR, BLOWER
DL3	DELAY/GAS 2.180 SEC DELAY ON BREAK
DL50	DELAY, 1.5 SEC. DELAY ON MAKE
DL55	DELAY, 2-STEP COMPRESSOR
K3, -1	CONTACTOR, BLOWER
K37	RELAY, BLOWER
K239	RELAY, Y1/W1 HI-LO SWITCHING RELAY
K249	CONTACTOR, COMPRESSOR OPERATION
K250	RELAY, Y2 HIGH SPEED BLOWER
L34	SOLENOID, TWO STAGE COMPRESSOR
S191	SWITCH, COMPRESSOR OPERATION

← DENOTES OPTIONAL COMPONENTS  
 ——— LINE VOLTAGE FIELD INSTALLED

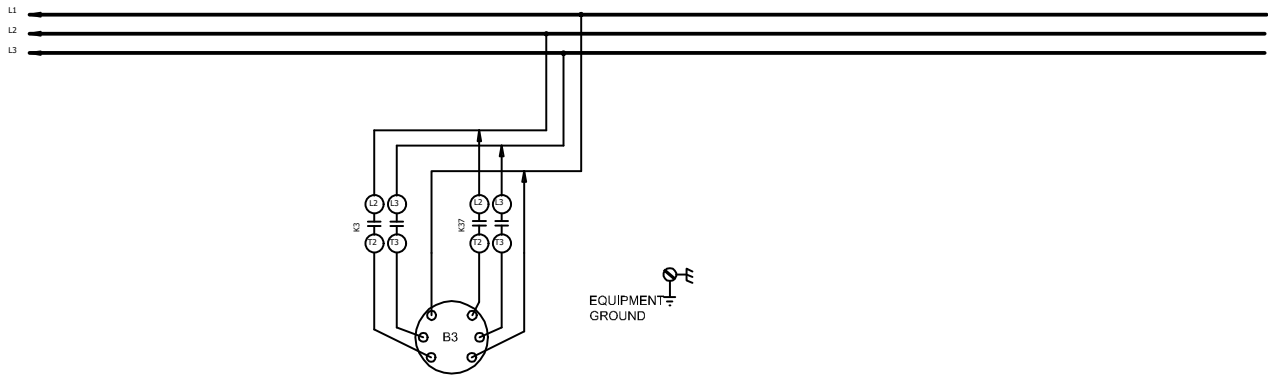

08/17		WIRING DIAGRAM	08/17
		<b>537886-02</b>	
COOLING			
2 SPEED A - BOX RAIDER - G,J,M,Y			
SECTION E			REV. 1
Supersedes		New Form No. <b>537886-02</b>	

# TYPICAL UNIT SCHEMATIC

This schematic is typical. See the wiring schematic on the unit for actual unit wiring.

24V POWER

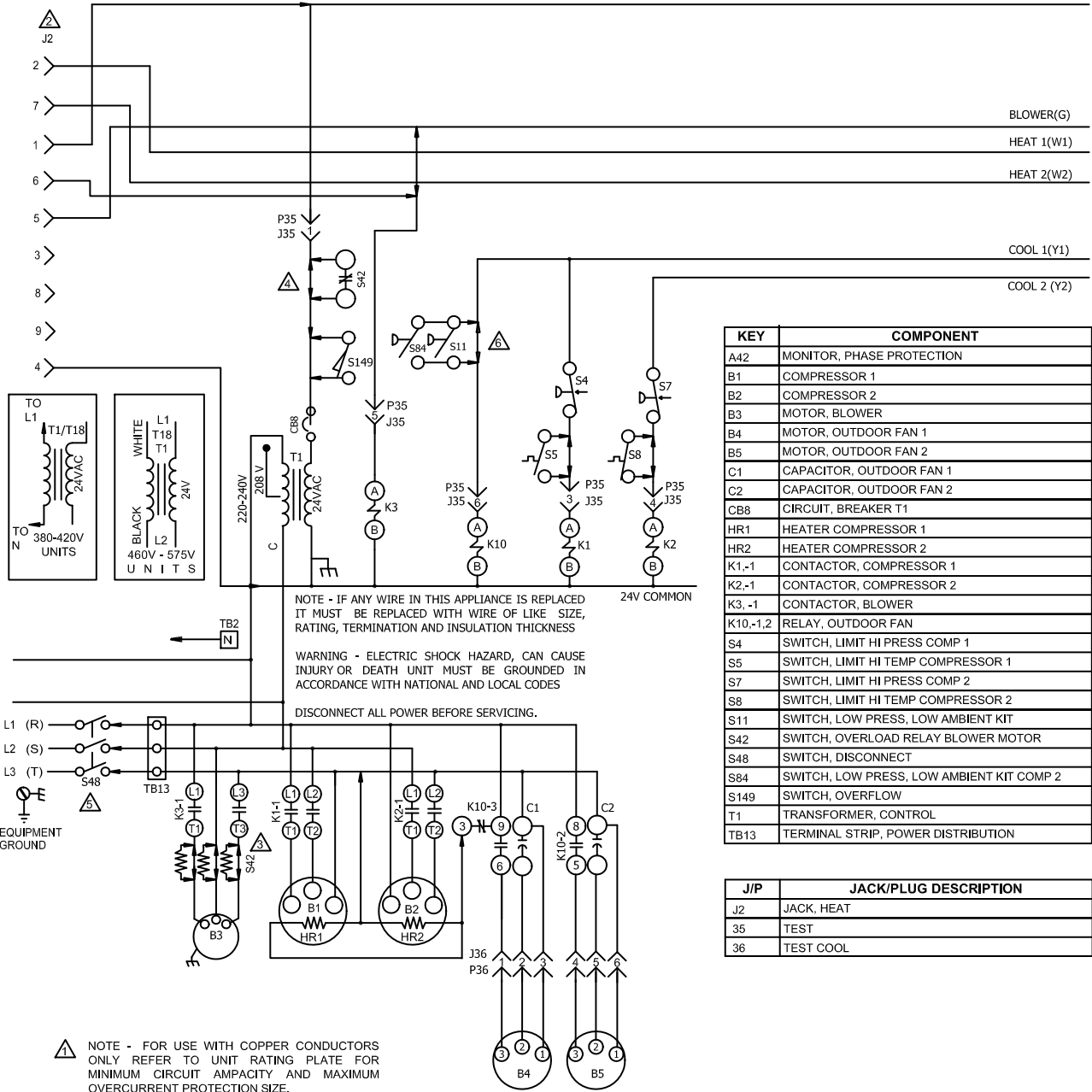

KEY	COMPONENT
A42	MONITOR, PHASE PROTECTION
B1	COMPRESSOR 1
B2	COMPRESSOR 2
B3	MOTOR, BLOWER
B4	MOTOR, OUTDOOR FAN 1
B5	MOTOR, OUTDOOR FAN 2
C1	CAPACITOR, OUTDOOR FAN 1
C2	CAPACITOR, OUTDOOR FAN 2
CB8	CIRCUIT, BREAKER T1
HR1	HEATER COMPRESSOR 1
HR2	HEATER COMPRESSOR 2
K1,-1	CONTACTOR, COMPRESSOR 1
K2,-1	CONTACTOR, COMPRESSOR 2
K3,-1	CONTACTOR, BLOWER
K10,-1,2	RELAY, OUTDOOR FAN
S4	SWITCH, LIMIT HI PRESS COMP 1
S5	SWITCH, LIMIT HI TEMP COMPRESSOR 1
S7	SWITCH, LIMIT HI PRESS COMP 2
S8	SWITCH, LIMIT HI TEMP COMPRESSOR 2
S11	SWITCH, LOW PRESS, LOW AMBIENT KIT
S42	SWITCH, OVERLOAD RELAY BLOWER MOTOR
S48	SWITCH, DISCONNECT
S84	SWITCH, LOW PRESS, LOW AMBIENT KIT COMP 2
S149	SWITCH, OVERFLOW
T1	TRANSFORMER, CONTROL
TB13	TERMINAL STRIP, POWER DISTRIBUTION

J/P	JACK/PLUG DESCRIPTION
J2	JACK, HEAT
35	TEST
36	TEST COOL

NOTE - IF ANY WIRE IN THIS APPLIANCE IS REPLACED IT MUST BE REPLACED WITH WIRE OF LIKE SIZE, RATING, TERMINATION AND INSULATION THICKNESS

WARNING - ELECTRIC SHOCK HAZARD, CAN CAUSE INJURY OR DEATH UNIT MUST BE GROUNDED IN ACCORDANCE WITH NATIONAL AND LOCAL CODES

DISCONNECT ALL POWER BEFORE SERVICING.

- ⚠ NOTE - FOR USE WITH COPPER CONDUCTORS ONLY REFER TO UNIT RATING PLATE FOR MINIMUM CIRCUIT AMPACITY AND MAXIMUM OVERCURRENT PROTECTION SIZE.
- ⚠ J2 IS USED ON ZGA UNITS OR FIELD INSTALLED ZCA WITH ELECTRICAL HEAT
- ⚠ IMPORTANT: TO PREVENT MOTOR BURNOUT, NEVER CONNECT MORE THAN ONE MOTOR LEAD TO ANY ONE CONNECTION. TAPE UNUSED MOTOR LEADS
- ⚠ S42 USED ON "M" VOLTAGE UNITS
- ⚠ S48 OR CB10 MAY BE USED
- ⚠ JUMPER WHEN S11 AND S84 ARE NOT USED

← DENOTES OPTIONAL COMPONENTS  
 — LINE VOLTAGE FIELD INSTALLED

04/14		WIRING DIAGRAM	04/14
		537671-01	
COOLING - CAV			
ZG - 092, 102, 120, 150 - G, J, M, Y			
SECTION B			REV. 0
Supersedes		New Form No. 537671-01	

## Repair Parts Listing

When ordering repair parts, include the complete model number and serial number listed on the CSA rating plate - e.g. ZGB060S4BH1Y.

### Gas Heat Section Parts

Heat Exchanger  
Combustion Air Assembly  
Combustion Air Proving Switch  
Burner Assembly  
Burner Manifold Assembly  
Main Burner Orifices  
Flame Roll-out Switches  
Auxiliary Limit Controls  
Ignition Electrode Assembly  
Ignition Lead  
Ignition Sensor Assembly  
Combination Gas Valve  
Limit Controls

### Cooling Parts

Compressors  
Condenser Fan Motors  
Condenser Fan Blades  
Condenser Fan Run Capacitors  
Fan Grille  
Indoor Blower Motors  
Blower Wheel  
Distributor / Restrictor  
Exhaust Fans (Opt.)

### Electrical Control Parts

Compressor Contactors  
Circuit Breakers (Opt.)  
Transformer (Control)  
Blower Contactor  
Limit, Blower Relay  
Heat Relays  
Condenser Fan Relays  
Capacitor CAB  
Relay CAB  
Disconnect Switch (Opt.)  
Ignition Control