

ROOFTOP UNIT KITS AND ACCESSORIES

507317-02
4/2021

BLOWER MOTOR AND IMPELLER REPLACEMENT KIT

INSTALLATION INSTRUCTIONS FOR BLOWER MOTOR & IMPELLER REPLACEMENT KIT (22A47 & 48; 612794-03 & 04) USED WITH LGM/LCM092-150U UNITS

Shipping and Packing List

Package 1 of 1 contains:

- 1- Blower motor and impeller assembly
- 1- Bag assembly containing:
 - 8-Bolts

⚠️ WARNING

Improper installation, adjustment, alteration, service or maintenance can cause property damage, personal injury or loss of life. Installation and service must be performed by a licensed professional HVAC installer or equivalent, service agency, or the gas supplier

⚠️ CAUTION

As with any mechanical equipment, contact with sharp sheet metal edges can result in personal injury. Take care while handling this equipment and wear gloves and protective clothing.

Application

The blower motor and impeller replacement kit is used on LGM/LCM092-150U units. 22A47 (612794-03) is used on Y volt units and 22A48 (612794-04) is used on G volt units.

Installation

- 1- Disconnect electrical power to unit. Wait five minutes before continuing service procedures to avoid electrical shock. This will allow internal capacitors time to fully discharge.
- 2- Open access panels as shown in figure 1.
- 3- Disconnect B3 Modbus connection and PT6 connection in the blower section. See figure 2.
- 4- Disconnect P48 in the controls area. See figure 3.
- 5- Cut wire ties where necessary and pull P48 wiring harness from control area into blower section.

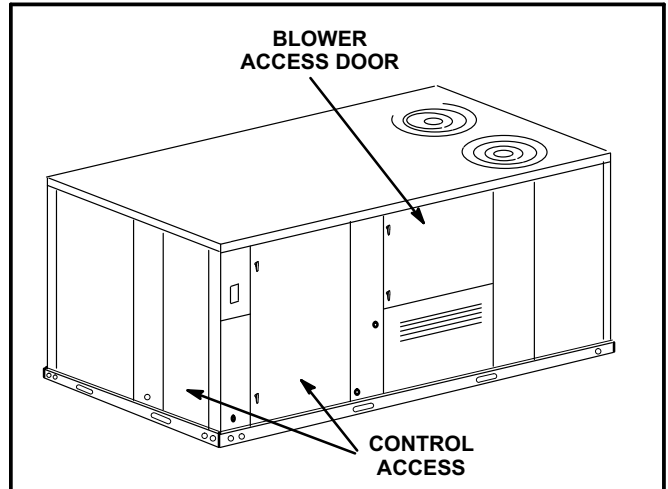

FIGURE 1

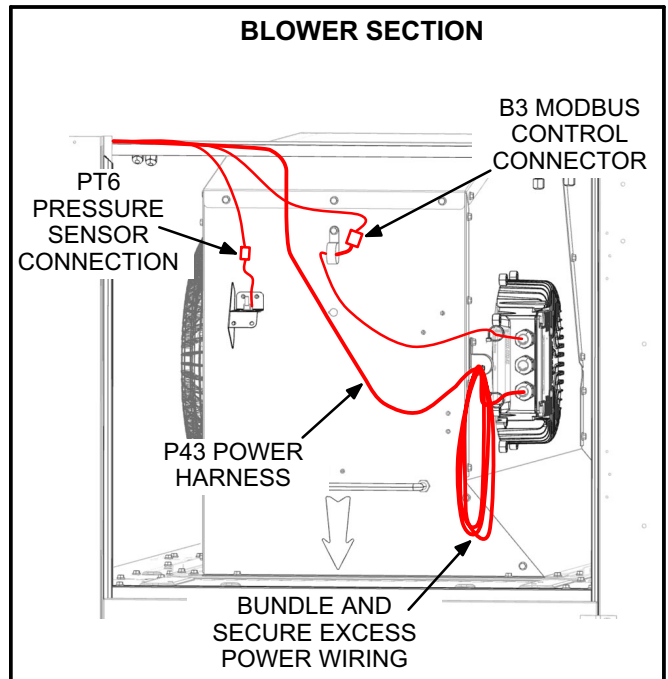

FIGURE 2

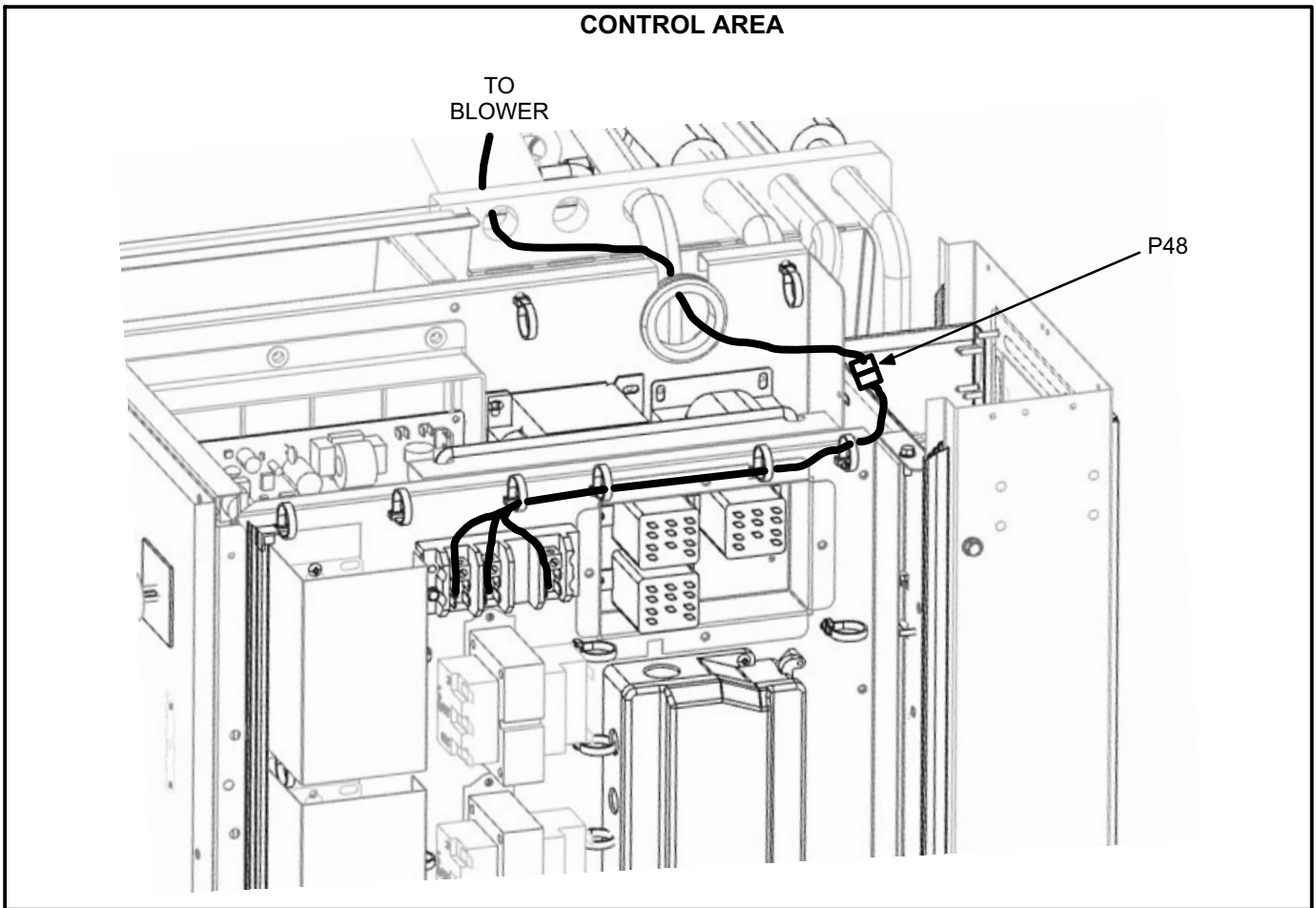

FIGURE 3

- 6- Remove four screws securing blower assembly to unit. See figure 5.
- 7- Use the handle on the blower assembly to slide the assembly out of unit.
- 8- Turn the blower assembly upside down. See figure 6.
- 9- Disconnect the pressure tube from the barb fitting on the orifice ring. The other end of the tubing remains connected to PT6 sensor. Route the disconnected end through the grommet to the outside of the housing. See figure 4.
- 10- Remove the inlet grill, orifice and the side of the housing shown in figure 7.
- 11- Remove the motor / impeller secured to the housing. See figures 6 and 7.
- 12- Carefully feed replacement motor wire harnesses through the motor mounting hole in housing. Install existing motor / impeller on replacement blower housing in the same manner the motor / impeller was removed from the discarded housing. Secure with 8 bolts provided in this kit. Tighten to 21.7 ft.-lbs.

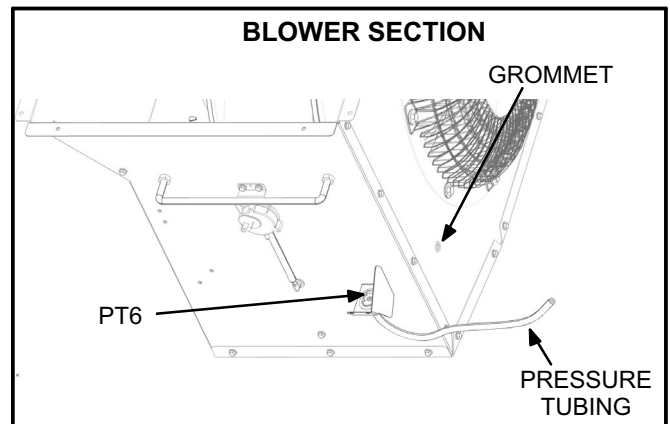

FIGURE 4

- 13- Replace the blower housing side, orifice and inlet grill which was previously disassembled. Tighten orifice screws to 10.8 ft.-lbs. Tighten inlet grill screws to 3.7 ft.-lbs.
- 14- Route the disconnected end of the pressure tubing through the grommet to the inside of the housing. Make sure the tube is fully connected to the barb fitting on the orifice ring. Avoid tight bends in the tubing.

- 15- Install blower assembly flanges into rails on the blower deck in the same manner it was removed. Secure into place using four screws shown in figure 5.
- 16- Uncoil wiring harness secured to replacement blower motor / impeller.
- 17- Route P48 end of harness through unit to control area in the same manner as it was removed.
- 18- Connect P48, B3 Modbus, and PT6 connections as shown in figures 2 and 3.

- 19- Bundle harnesses and use wire ties to secure kit harnesses to unit harnesses in the same manner they were removed.

Warranty Return

Package malfunctioned motor / impeller in the same manner as the replacement was provided. Use the same packaging. Return malfunctioned motor / impeller along with a copy of the warranty claim form to the nearest LPP store or warehouse.

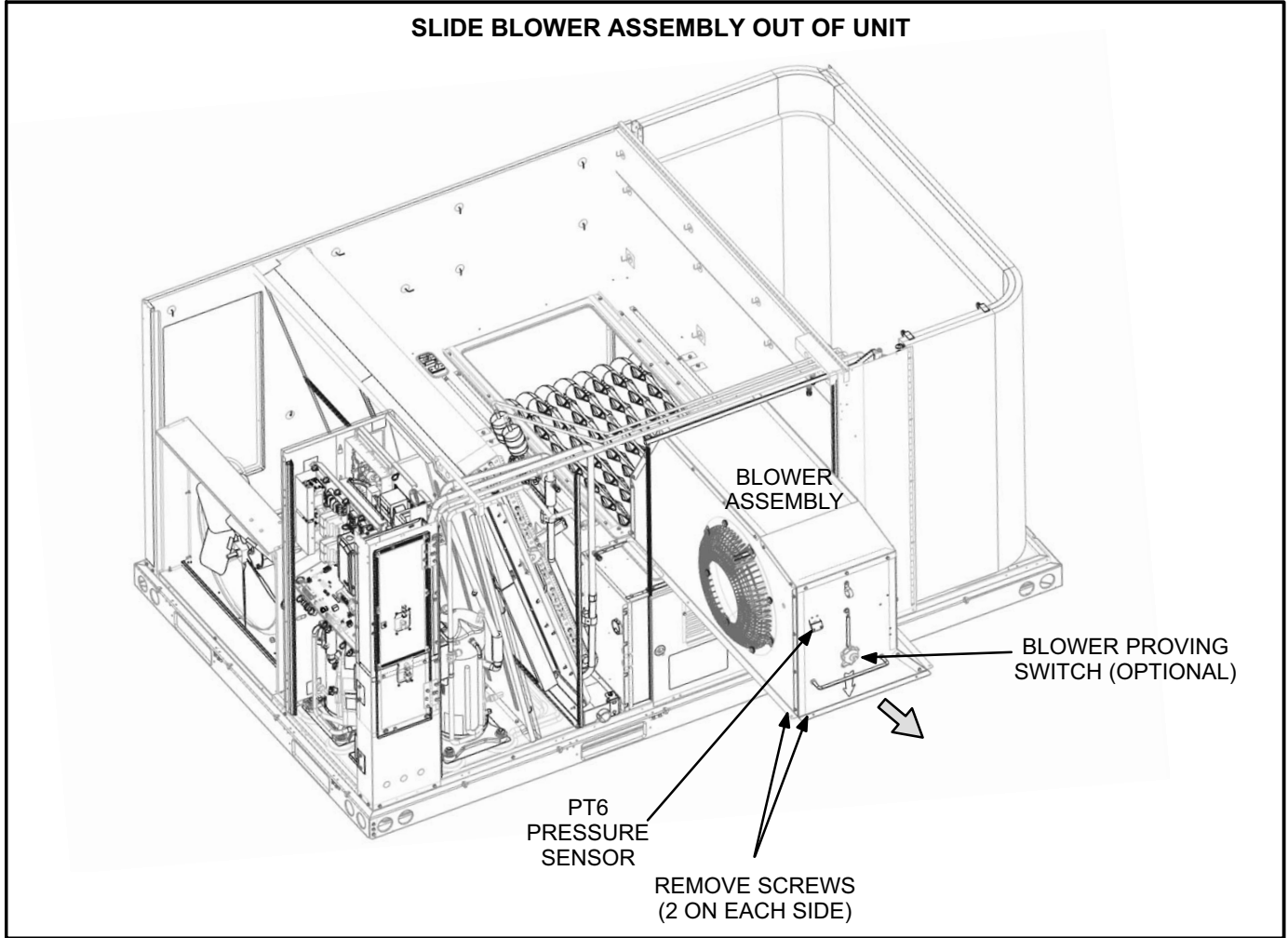

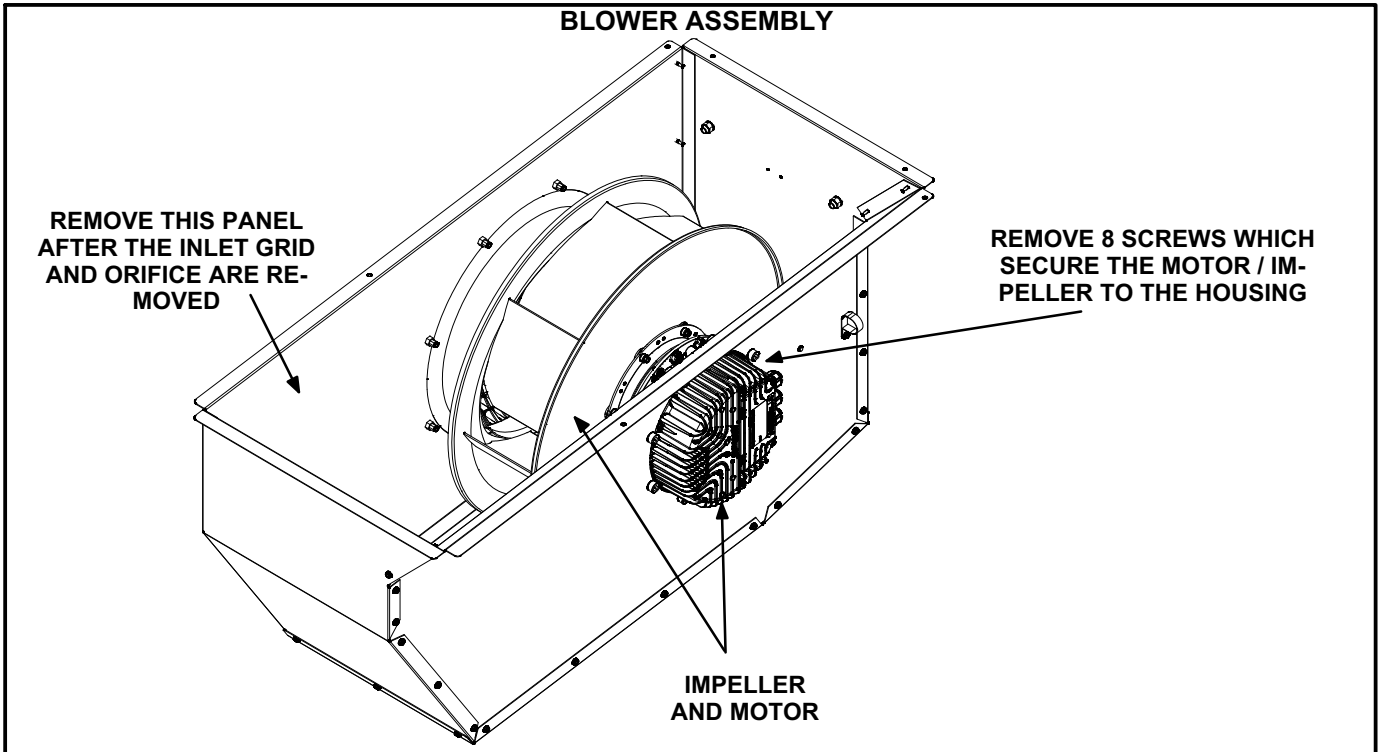

FIGURE 6

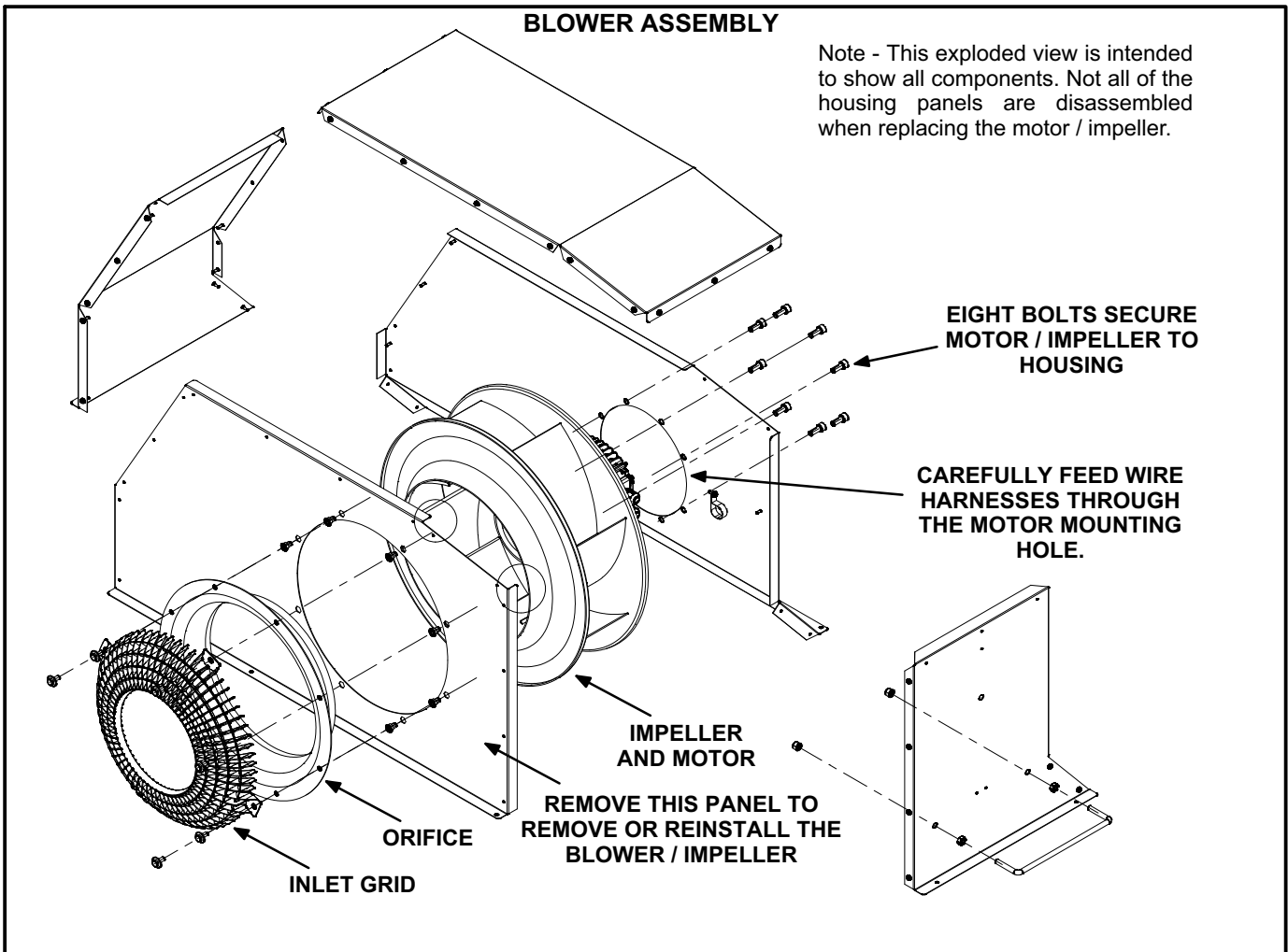

FIGURE 7