



© 2018 Lennox Industries Inc.
Dallas, Texas, USA

Certified by SAI Global
GSCS20254

INSTALLATION INSTRUCTIONS

ML180UHA

MERIT® SERIES GAS FURNACE
UPFLOW / HORIZONTAL AIR DISCHARGE

507407-03
10/2018
Supersedes 507407-02

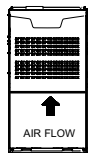

UPFLOW

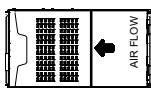

HORIZONTAL LEFT

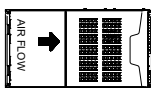

HORIZONTAL RIGHT

**THIS MANUAL MUST BE LEFT WITH THE
HOMEOWNER FOR FUTURE REFERENCE**

 This is a safety alert symbol and should never be ignored. When you see this symbol on labels or in manuals, be alert to the potential for personal injury or death.

WARNING

Improper installation, adjustment, alteration, service or maintenance can cause property damage, personal injury or loss of life. Installation and service must be performed by a licensed professional HVAC installer (or equivalent), service agency or the gas supplier.

CAUTION

As with any mechanical equipment, personal injury can result from contact with sharp sheet metal edges. Be careful when you handle this equipment.

Table of Contents

Unit Dimensions	2	Electrical	16
ML180UHA Gas Furnace	3	Integrated Control	17
Shipping and Packing List	3	Unit Start-Up	19
Requirements	3	Gas Pressure Adjustment	20
General	4	High Altitude	20
Combustion, Dilution & Ventilation Air	4	Proper Combustion	20
Setting Equipment	7	Other Unit Adjustments	21
Filters	11	Service	22
Duct System	11	Repair Parts	23
Venting	12	Specifications	24
Gas Piping	14		



Unit Dimensions - mm

¹NOTE - 60C and 60D units that require air volumes over 1800 cfm (850 L/s) must have one of the following:

1. Single side return air with transition to accommodate 508 x 635 x 25 mm cleanable air filter. (Required to maintain proper air velocity.)
 2. Single side return with optional return air base.
 3. Bottom return air.
 4. Return air from both sides.
 5. Bottom and one side return air.
- See Blower Performance Tables for additional information.

²Flue outlet may be horizontal but furnace must be vented vertically

³Optional external side return air filter kit cannot be used with the optional Return Air Base.

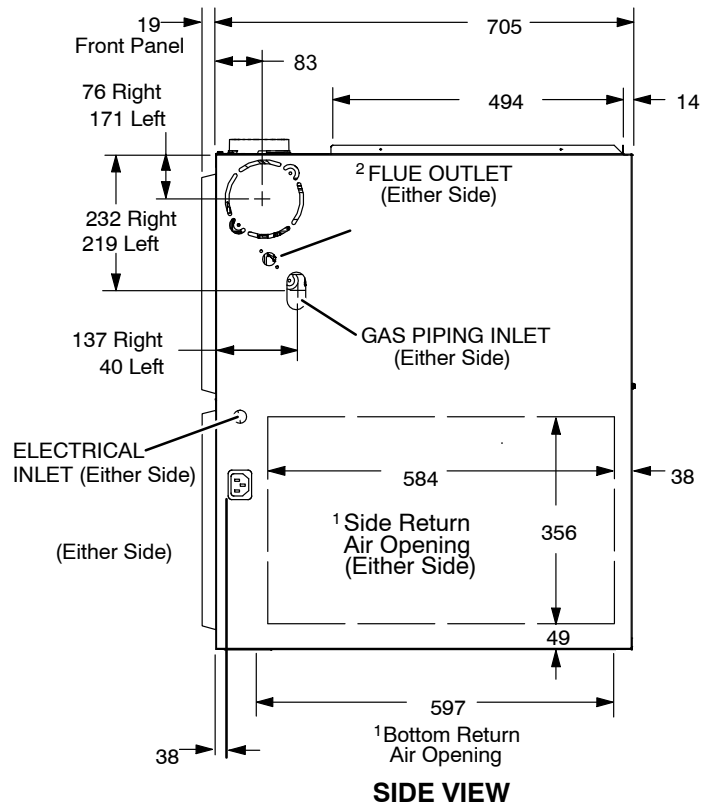
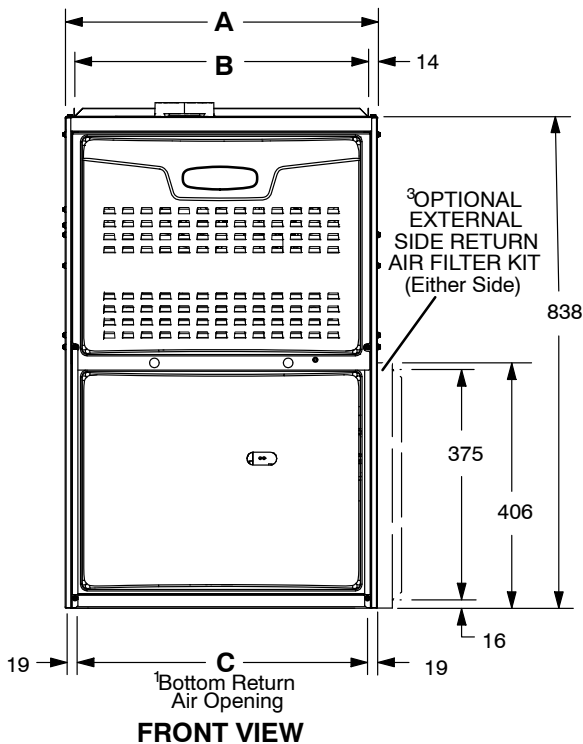
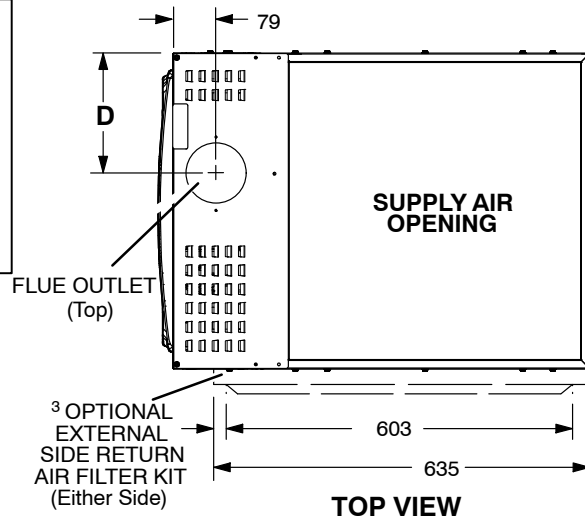

ML180UHA Model No.	A	B	C	D
	mm	mm	mm	mm
070AP36A	368	340	330	121
090AP48B	446	416	406	159
110AP36C 110AP60C	533	504	495	203
135AP60D	622	546	584	248

ML180UHA Gas Furnace

The ML180UHA unit is shipped ready for use with Natural gas (LP/Propane changeover kits available), and for installation in the upflow or horizontal right position (for horizontal left position the combustion air pressure switch must be moved). The furnace is shipped with the bottom panel in place. The bottom panel must be removed if the unit is to be installed in a horizontal application. The panel may also be removed in upflow applications with bottom return air.

Shipping and Packing List

Package 1 of 1 contains

- 1 - Assembled ML180UHA unit
- 1 - Bag assembly containing the following:
 - 2 - Screws
 - 1 - Snap bushing
 - 1 - Snap plug
 - 1 - Wire tie
 - 1 - Vent warning label
 - 1 - Owner's manual
- 1 - Bag assembly containing the following:
 - 1 - 2.5 m Power cord

The following items may be ordered separately:

- 1 - Thermostat
- 1 - Suspension kit (for horizontal installations)
- 1 - Propane/LP changeover kit
- 1 - Return air base
- 1 - High altitude kit
- 1 - Side filter kit

Check equipment for shipping damage. If you find any damage, immediately contact the last carrier.

Requirements

The ML180UHA furnace is approved for installation for inside of building only, with clearances as listed in figure 6. (Accessibility and service clearances must NOT take precedence over fire protection clearances). Installation of Lennox forced air central furnaces must be in accordance with these instructions, local gas fitting regulations, municipal building codes, electrical wiring regulations and the current edition of the Australian Gas Installation Code (AS/NZS5601).

The acceptable natural gas Wobbe number values for use with Lennox furnaces are shown in Table 1.

TABLE 1

Wobbe Number*	Min	Normal	Max
	46.95 mj / m ³ (1260 Btu / ft ³)	50.15 mj / m ³ (1346 Btu / ft ³)	53.28 mj / m ³ (1430 Btu / ft ³)
Gas Properties 101.3 kPa, 15° C Dry bulb (14.73 psia, 60° F Dry Bulb)			

* Wobbe number = heating value ÷ square root of specific gravity

If you need to know whether a gas is acceptable, request the Wobbe number from your gas supplier and compare to the chart. If the number is within the ranges listed for Natural gas, the gas is acceptable to use. If the Wobbe number is outside the acceptable ranges, the gas is not acceptable to use.

As LP (Propane) is a regulated/manufactured gas, a Wobbe number is not required to determine acceptability. For propane installations, the acceptable heating value range is 93.2 MJ / m³ (2500 btu/ft³) +/- 5%.

NOTE - Lennox does not recommend using unrefined or "well head" gas on Lennox gas-fired furnaces. The quality of gas is not controlled and may have contaminants which may lead to corrosion, premature heat exchanger failure or may void the equipment warranty. The information provided above is intended for evaluating fuel gases available commercially through gas utilities or LP (propane) suppliers.

Adequate clearance must be made around the air openings into the vestibule area. Provisions shall be made for proper operation and for combustion air and ventilation air supply according to the current edition of the Australian Gas Installation Code (AS/NZS5601).

NOTE - For installation on combustible floors, the furnace shall not be installed directly on carpeting, tile, or other combustible material other than wood flooring.

For installation in a residential garage, the furnace must be installed so that the burner(s) and the ignition source are located no less than 457 mm (18 in) above the floor. The furnace must be located or protected to avoid physical damage by vehicles. When a furnace is installed in a public garage, hangar, or other building that has a hazardous atmosphere, the furnace must be installed according to recommended good practice requirements and current edition of the Australian Gas Installation Code (AS/NZS5601).

Unit must be adjusted to obtain a temperature rise within the range specified on appliance rating plate.

This ML180UHA furnace must be installed so that its electrical components are protected from water.

When this furnace is used with cooling units, it shall be installed in parallel with, or on the upstream side of, cooling units to avoid condensation in the heating compartment. With a parallel flow arrangement, a damper (or other means to control the flow of air) must adequately prevent chilled air from entering the furnace. If the damper is manually operated, it must be equipped to prevent operation of either the heating or the cooling unit, unless it is in the full **HEAT** or **COOL** setting.

When installed, this furnace must be electrically grounded according to local codes.

All field wiring must comply with the current edition of Australian Standard AS3000.

When furnace is installed so that supply ducts carry air circulated by furnace to areas outside of space containing furnace, return air shall be handled by a duct(s) sealed to a furnace casing and terminating outside space containing furnace.

NOTE - ML180UHA series units must not be used as a "construction heater" during any phase of construction. Very low temperatures, harmful vapors and misplacement of the filters will damage the unit and its efficiency.

The ML180UHA furnace may be installed in alcoves, closets, attics, basements, garages, crawl spaces and utility rooms in any of its approved installation positions.

This furnace design has not been certified for installation in mobile homes, recreational vehicles, or outdoors.

⚠ WARNING
The blower access panel must be securely in place when the blower and burners are operating. Gas fumes, which could contain carbon monoxide, can be drawn into living space resulting in personal injury or death.

General

⚠ WARNING
Do not place articles on or against this appliance.
Do not store flammable materials near this appliance.
Do not spray aerosols in the vicinity of this appliance while in operation.
Do not modify this appliance.
Refer to the unit serial / data badge located in the electrical compartment for gas type and gas consumption information.

These instructions are intended as a general guide and do not supersede local codes in any way. Consult authorities having jurisdiction before installation.

In addition to the requirements outlined previously, the following general recommendations must be considered when installing a ML180UHA furnace:

- Place the furnace as close to the center of the air distribution system as possible. The furnace should also be located close to the chimney or vent termination point.
- Do not install the furnace where drafts might blow directly into it. This could cause improper combustion and unsafe operation.
- Do not block the furnace combustion air openings with clothing, boxes, doors, etc. Air is needed for proper combustion and safe unit operation.
- When the furnace is installed in an attic or other insulated space, keep insulation away from the furnace.
- Please consult the manufacturer of your evaporator coil for their recommendations on distance required between the heat exchanger and their drain pan. Adequate space must be provided between the drain pan and the furnace heat exchanger.

Combustion, Dilution & Ventilation Air

In the past, there was no problem in bringing in sufficient outdoor air for combustion. Infiltration provided all the air that was needed. In today's homes, tight construction practices make it necessary to bring in air from outside for combustion. Take into account that exhaust fans, appliance vents, chimneys, and fireplaces force additional air that could be used for combustion out of the house. Unless outside air is brought into the house for combustion, negative pressure (outside pressure is greater than inside pressure) will build to the point that a downdraft can occur in the furnace vent pipe or chimney. As a result, combustion gases enter the living space creating a potentially dangerous situation.

Refer to and comply with the current edition of the Australian Gas Installation Code (AS/NZS5601) for appliance combustion air requirements.

⚠ CAUTION
Do not install the furnace in a corrosive or contaminated atmosphere. Meet all combustion and ventilation air requirements, as well as all local codes.

⚠ CAUTION

Insufficient combustion air can cause headaches, nausea, dizziness or asphyxiation. It will also cause excess water in the heat exchanger resulting in rusting and premature heat exchanger failure. Excessive exposure to contaminated combustion air will result in safety and performance related problems. Avoid exposure to the following substances in the combustion air supply:

- Permanent wave solutions
- Chlorinated waxes and cleaners
- Chlorine base swimming pool chemicals
- Water softening chemicals
- De-icing salts or chemicals
- Carbon tetrachloride
- Halogen type refrigerants
- Cleaning solvents (such as perchloroethylene)
- Printing inks, paint removers, varnishes, etc.
- Hydrochloric acid
- Cements and glues
- Antistatic fabric softeners for clothes dryers
- Masonry acid washing materials

All gas-fired appliances require air for the combustion process. If sufficient combustion air is not available, the furnace or other appliances will operate inefficiently and unsafely. Enough air must be provided to meet the needs of all fuel-burning appliances and appliances such as exhaust fans which force air out of the house. When fireplaces, exhaust fans, or clothes dryers are used at the same time as the furnace, much more air is necessary to ensure proper combustion and to prevent a downdraft. Insufficient air causes incomplete combustion which can result in carbon monoxide.

In addition to providing combustion air, fresh outdoor air dilutes contaminants in the indoor air. These contaminants may include bleaches, adhesives, detergents, solvents and other contaminants which can corrode furnace components.

The requirements for providing air for combustion and ventilation depend largely on whether the furnace is installed in an unconfined or a confined space.

Unconfined Space

An unconfined space is an area such as a basement or large equipment room with a volume greater than 1.42 m³ (50 cubic feet) per .29 kW (1,000 Btu) per hour of the combined input rating of all appliances installed in that space. This space also includes adjacent rooms which are not separated by a door. Though an area may appear to be unconfined, it might be necessary to bring in outdoor air for combustion if the structure does not provide enough air by infiltration. If the furnace is located in a building of tight

construction with weather stripping and caulking around the windows and doors, follow the procedures in the air from outside section.

Confined Space

A confined space is an area with a volume less than 1.42 m³ (50 cubic feet) per .29 kW (1,000 Btu) per hour of the combined input rating of all appliances installed in that space. This definition includes furnace closets or small equipment rooms.

When the furnace is installed so that supply ducts carry air circulated by the furnace to areas outside the space containing the furnace, the return air must be handled by ducts which are sealed to the furnace casing and which terminate outside the space containing the furnace. This is especially important when the furnace is mounted on a platform in a confined space such as a closet or small equipment room. Even a small leak around the base of the unit at the platform or at the return air duct connection can cause a potentially dangerous negative pressure condition. Air for combustion and ventilation can be brought into the confined space either from inside the building or from outside.

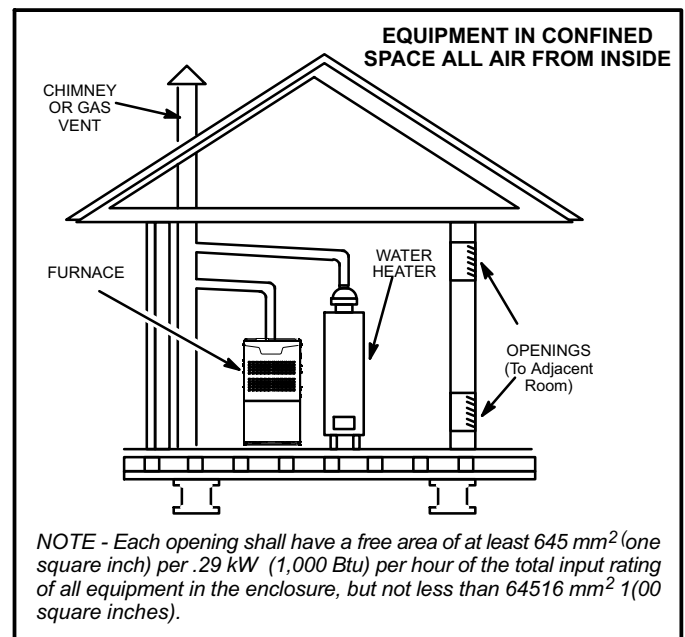

FIGURE 1

Air from Inside

If the confined space that houses the furnace adjoins a space categorized as unconfined, air can be brought in by providing two permanent openings between the two spaces. Each opening must have a minimum free area of 645 mm² (1 square inch) per .29 kW (1,000 Btu) per hour of total input rating of all gas-fired equipment in the confined space. Each opening must be at least 64516 mm² (100 square inches). One opening shall be within 305 mm (12 inches) of the top of the enclosure and one opening within 305 mm (12 inches) of the bottom. See figure 1.

Air from Outside

If air from outside is brought in for combustion and ventilation, the confined space must have two permanent openings. One opening shall be within 305 mm (12 inches) of the top of the enclosure and one opening within 305 mm (12 inches) of the bottom. These openings must communicate directly or by ducts with the outdoors or spaces (crawl or attic) that freely communicate with the outdoors or indirectly through vertical ducts. Each opening shall have a minimum free area of 645 mm² (1 square inch) per 1.17 kW (4,000 Btu) per hour of total input rating of all equipment in the enclosure. See figures 2 and 3. When communicating with the outdoors through horizontal ducts, each opening shall have a minimum free area of 645 mm² (1 square inch) per .56 kW (2,000 Btu) per total input rating of all equipment

in the enclosure. See figure 4.

When ducts are used, they shall be of the same cross-sectional area as the free area of the openings to which they connect. The minimum dimension of rectangular air ducts shall be no less than 75 mm (3 inches). In calculating free area, the blocking effect of louvers, grilles, or screens must be considered. If the design and free area of protective covering is not known for calculating the size opening required, it may be assumed that wood louvers will have 20 to 25 percent free area and metal louvers and grilles will have 60 to 75 percent free area. Louvers and grilles must be fixed in the open position or interlocked with the equipment so that they are opened automatically during equipment operation.

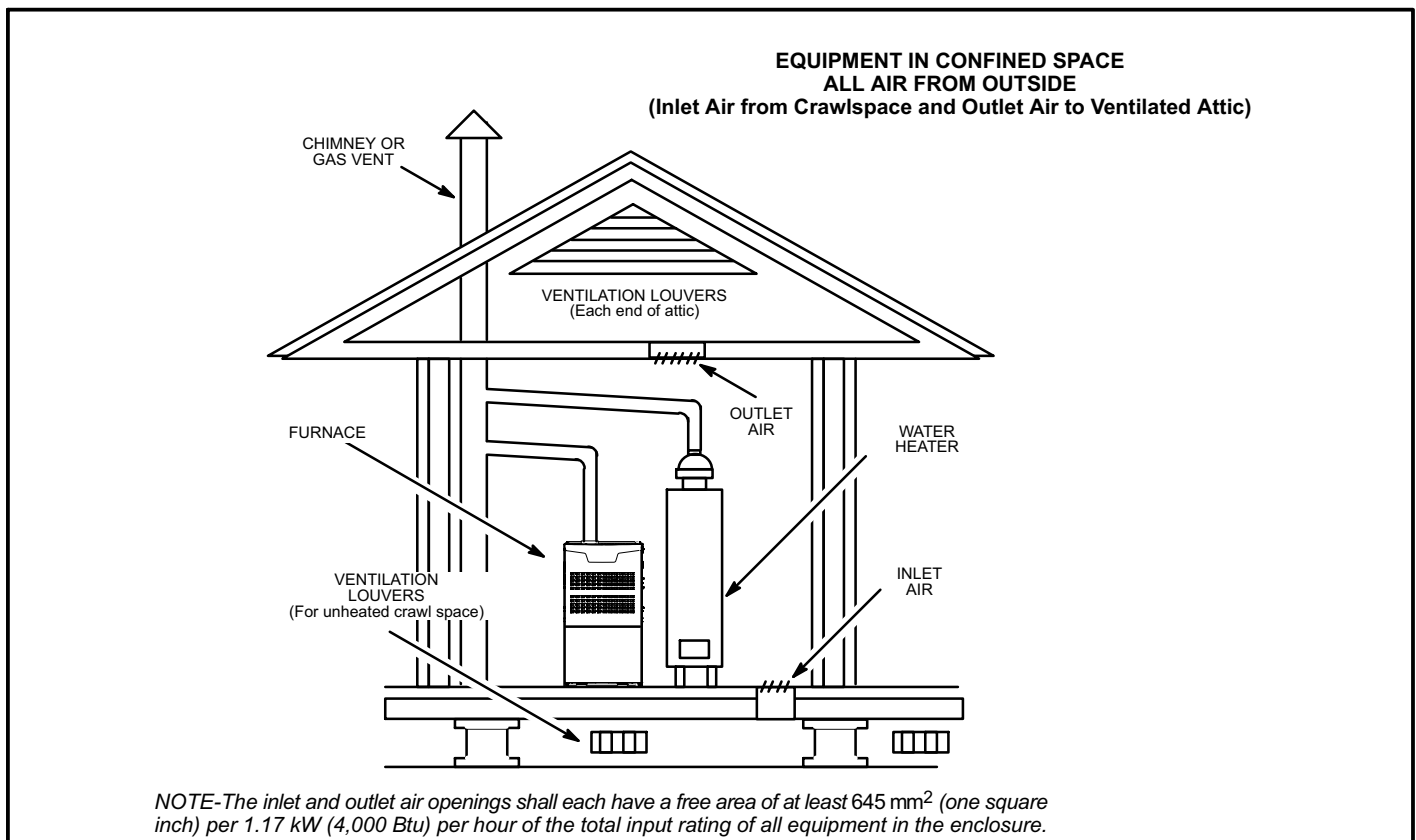

FIGURE 2

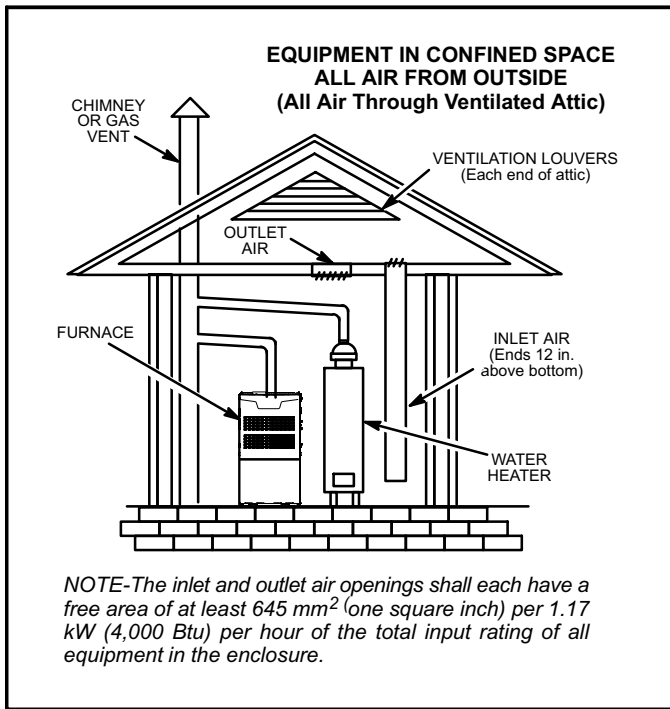

FIGURE 3

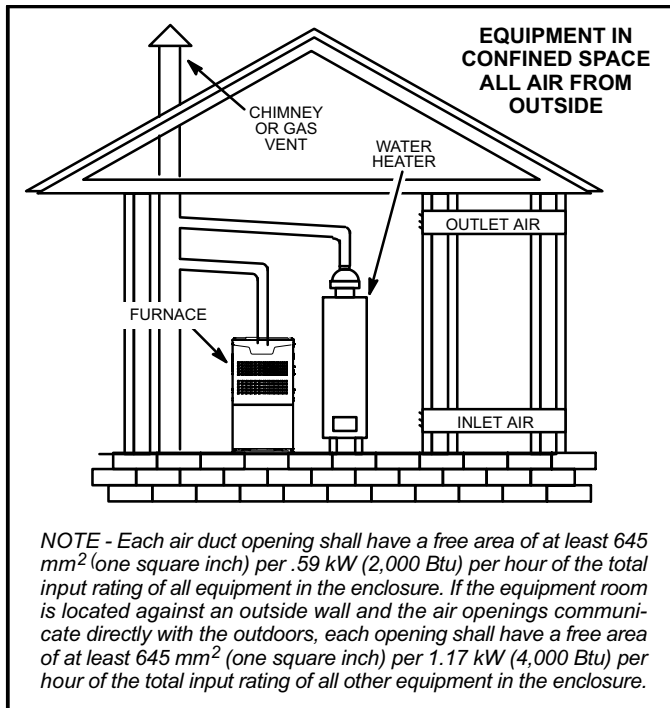

FIGURE 4

Setting Equipment

⚠ WARNING

Do not install the furnace on its front or its back. Do not connect the return air ducts to the back of the furnace. Doing so will adversely affect the operation of the safety control devices, which could result in personal injury or death.

NOTE - As an option, rubberlike pads defined as having an elastic texture resembling rubber in flexibility or toughness, may be placed under each corner of the furnace as appropriate to the application.

The ML180UHA gas furnace can be installed as shipped in either the upflow position or the horizontal position. Select a location that allows for the required clearances that are listed on the unit nameplate. Also consider gas supply connections, electrical supply, vent connection, and installation and service clearances [610 mm (24 inches)] at unit front. *The unit must be level.*

*NOTE - Units with 1/2 hp blower motors (ML180UH110AP36C and ML180UH090AP48B) are equipped with three flexible legs and one rigid leg. See figure 5. The rigid leg is equipped with a shipping bolt and a flat white plastic washer (rather than the rubber mounting grommet used with a flexible mounting leg). **The bolt and washer must be removed before the furnace is placed into operation.** After the bolt and washer have been removed, the rigid leg will not touch the blower housing.*

NOTE - ML180UH090AP48B, & ML180UH110AP36C are also equipped with a shipping pad under the blower housing. Remove the shipping pad prior to operation.

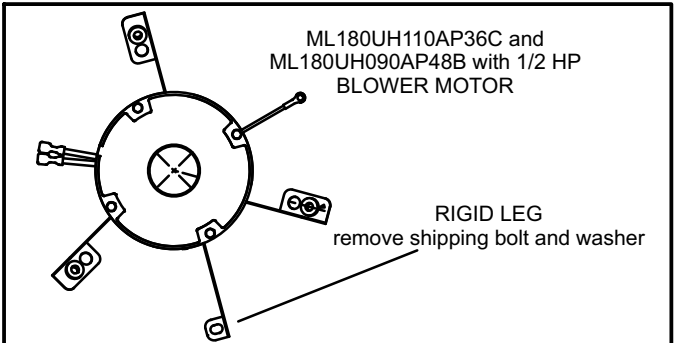

FIGURE 5

Upflow Applications

Allow for clearances to combustible materials as indicated on the unit nameplate. Minimum clearances for closet or alcove installations are shown in figure 6.

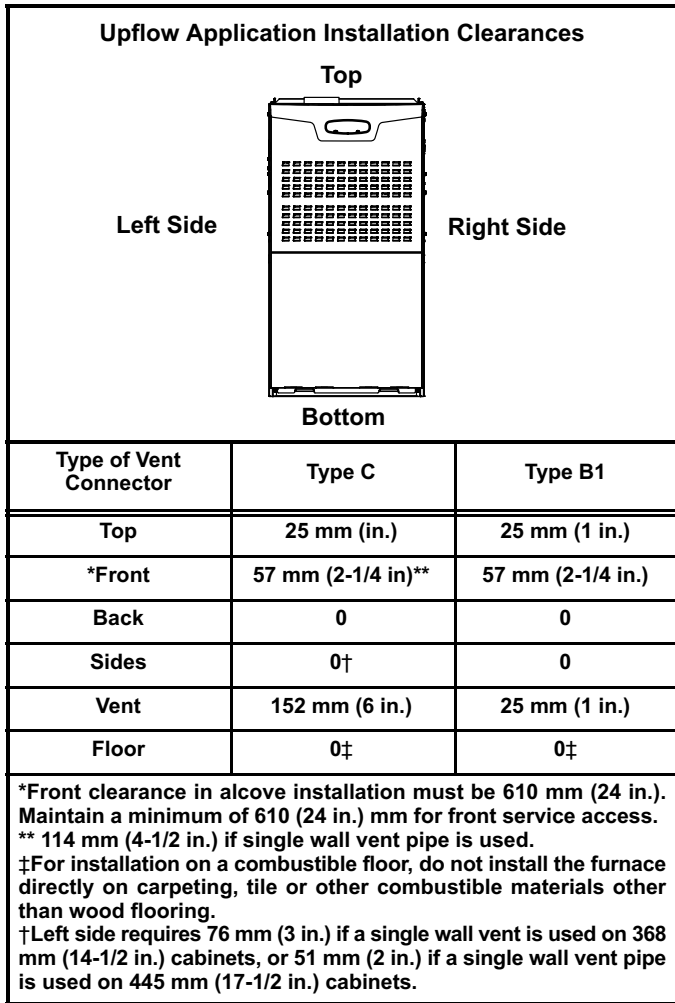

FIGURE 6

Return Air - Upflow Applications

Return air can be brought in through the bottom or either side of the furnace installed in an upflow application. If the furnace is installed on a platform with bottom return, make an airtight seal between the bottom of the furnace and the platform to ensure that the furnace operates properly and

safely. The furnace is equipped with a removable bottom panel to facilitate installation.

Markings are provided on both sides of the furnace cabinet for installations that require side return air. Cut the furnace cabinet at the maximum dimensions shown on page 2.

NOTE - 60C and 60D units that require air volumes over 850 L/s (1800cfm) must have one of the following:

- 1 - Single side return air with transition to accommodate 508 x 635 x 25 mm (20 x 25 x 1 in.) cleanable air filter. (Required to maintain proper air velocity.) See figure 7.
- 2 - Single side return air with optional return airbase. See figure 8.
- 3 - Bottom return air.
- 4 - Return air from both sides.
- 5 - Bottom and one side return air.

Refer to Product Specifications bulletin for additional information.

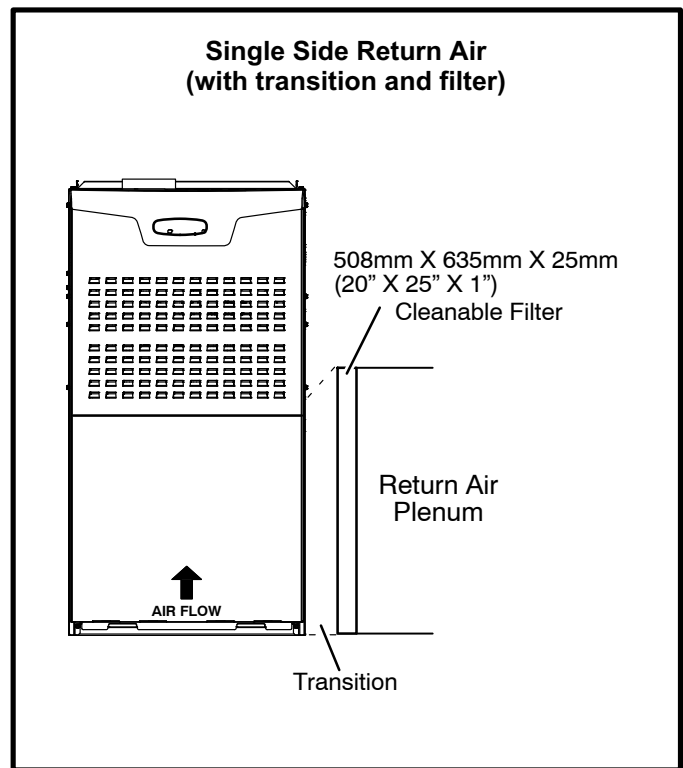
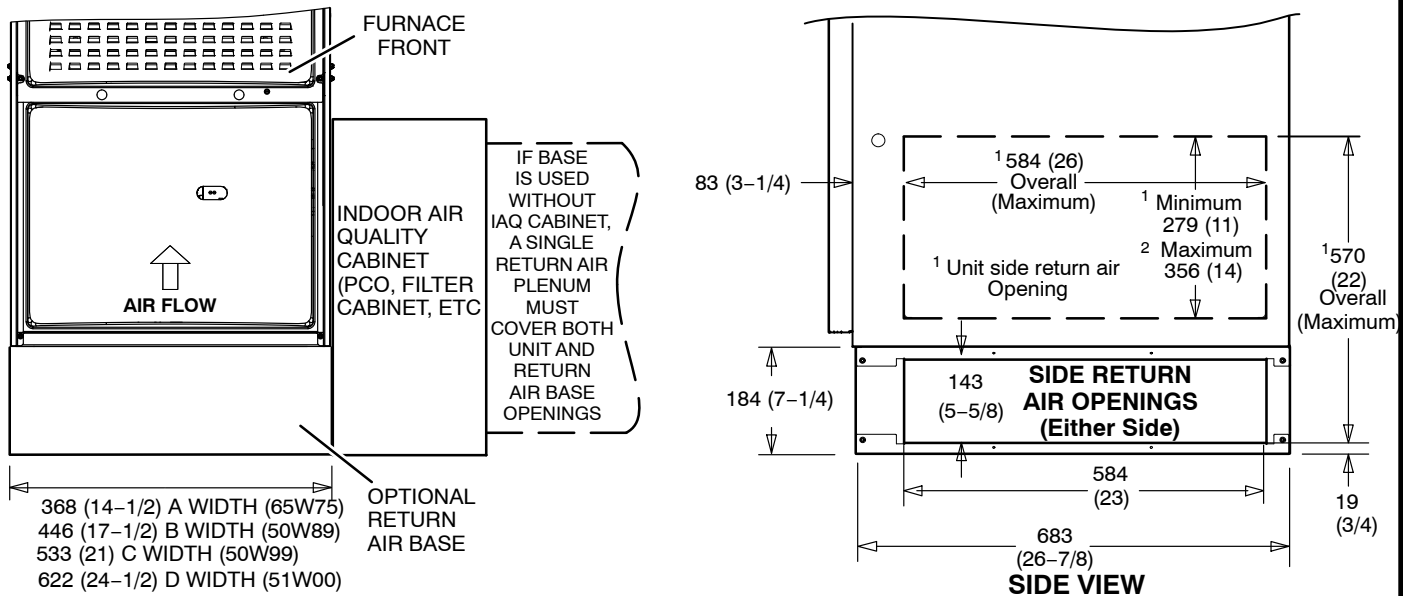

FIGURE 7

**Optional Return Air Base
(Upflow Applications Only -- For use with A, B, C and D cabinets)**



NOTE- Optional Side Return Air Filter Kits are not for use with Optional Return Air Base.

¹ Both the unit return air opening and the base return air opening must be covered by a single plenum or IAQ cabinet.

Minimum unit side return air opening dimensions for units requiring 850 L/s (1800 cfm) or more of air (W x H): 584 x 279 mm. (23 X 11 in.)

The opening can be cut as needed to accommodate plenum or IAQ cabinet while maintaining dimensions shown.

Side return air openings must be cut in the field. There are cutting guides stenciled on the cabinet for the side return air opening. The size of the opening must not extend beyond the markings on the furnace cabinet.

² To minimize pressure drop, the largest opening height possible [up to 356 mm (14 in.)] is preferred.

FIGURE 8

Removing the Bottom Panel

Remove the two screws that secure the bottom cap to the furnace. Pivot the bottom cap down to release the bottom panel. Once the bottom panel has been removed, reinstall the bottom cap. See figure 9.

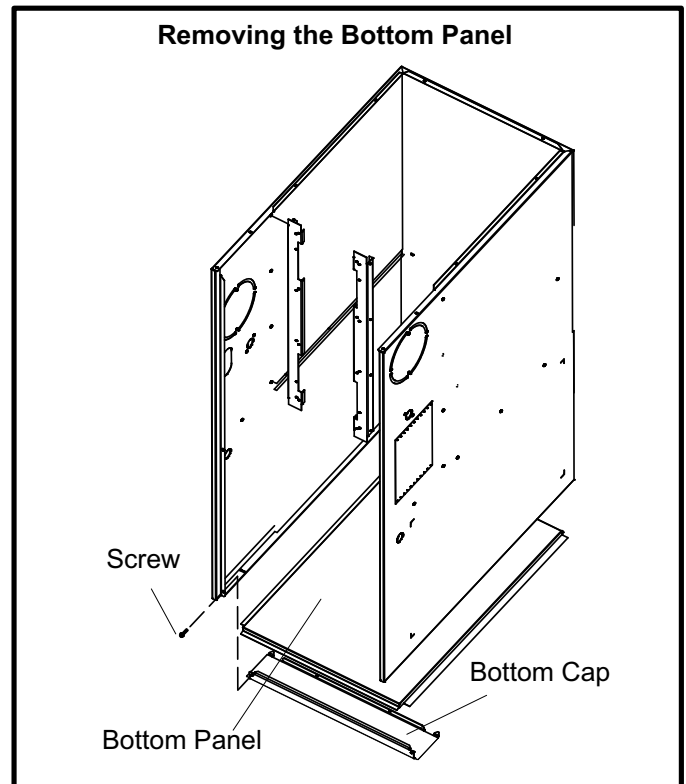

FIGURE 9

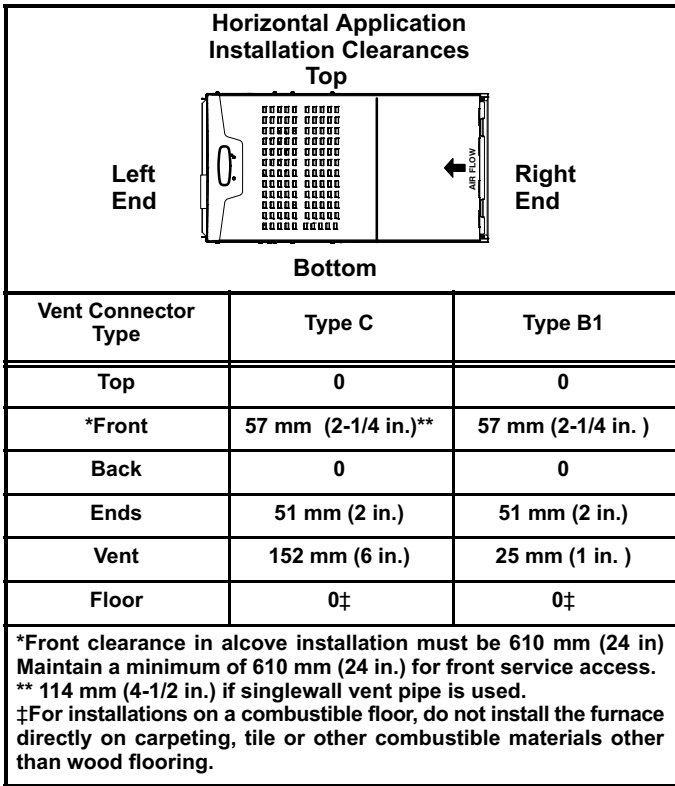

FIGURE 10

Horizontal Applications

The ML180UHA furnace can be installed in horizontal applications. Order horizontal suspension kit (51W10) from Lennox, or use equivalent suspension method.

Allow for clearances to combustible materials as indicated on the unit nameplate. Minimum clearances for closet or alcove installations are shown in figure 10.

This furnace may be installed in either an attic or a crawlspace. Either suspend the furnace from roof rafters or floor joists, as shown in figure 11, or install the furnace on a platform, as shown in figure 12.

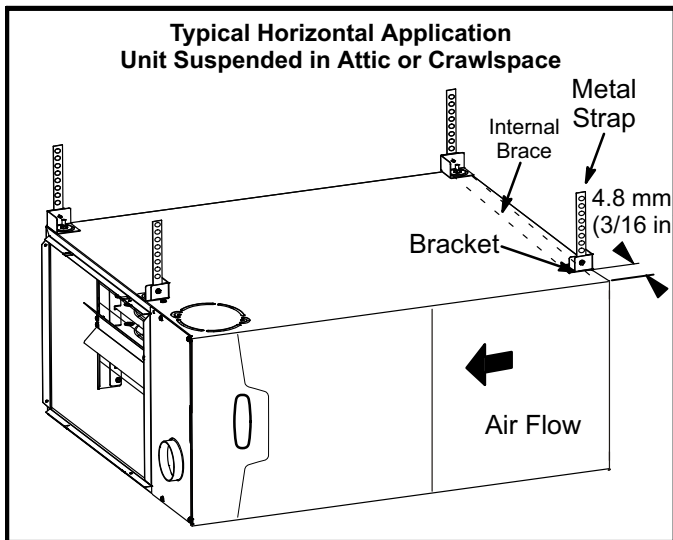

FIGURE 11

NOTE - Heavy-gauge perforated sheet metal straps may be used to suspend the unit from roof rafters or ceiling joists. When straps are used to suspend the unit in this way, support must be provided for both the ends. The straps must not interfere with the plenum or exhaust piping installation. **Cooling coils and supply and return air plenums must be supported separately.**

NOTE - When the furnace is installed on a platform in a crawlspace, it must be elevated enough to avoid water damage and to allow the evaporator coil to drain.

Return Air -- Horizontal Applications

Return air must be brought in through the end of a furnace installed in a horizontal application. The furnace is equipped with a removable bottom panel to facilitate installation. See figure 9.

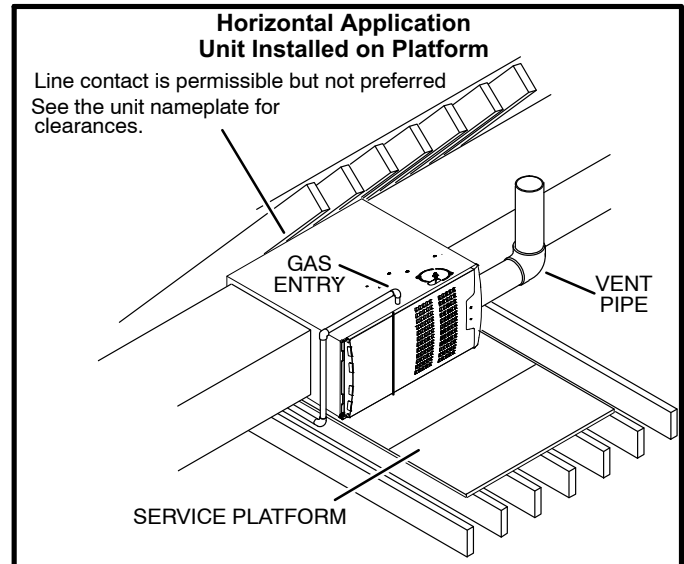

FIGURE 12

CAUTION

If this unit is being installed in a space serviced by an exhaust fan, power exhaust fan, or other device which may create a negative pressure in the space, take care when sizing the inlet air opening. The inlet air opening must be sized to accommodate the maximum volume of exhausted air as well as the maximum volume of combustion air required for all gas appliances serviced by this space.

⚠ WARNING

Improper installation of the furnace can result in personal injury or death. Combustion and flue products must never be allowed to enter the return air system or the living space. Use screws and joint tape to seal the return air system to the furnace.

In platform installations with bottom return air, the furnace should be sealed airtight to the return air plenum. A door must never be used as a portion of the return air duct system. The base must provide a stable support and an airtight seal to the furnace. Allow absolutely no sagging, cracks, gaps, etc.

The return and supply air duct systems must never be connected to or from other heating devices such as a fireplace or stove, etc. Fire, explosion, carbon monoxide poisoning, personal injury and/or property damage could result.

⚠ WARNING

The blower access panel must be securely in place when the blower and burners are operating. Gas fumes, which could contain carbon monoxide, can be drawn into living space resulting in personal injury or death.

Filters

This unit is not equipped with a filter or rack. A field-provided high-velocity filter is required for the unit to operate properly. Table 2 lists recommended filter sizes.

A filter must be in place any time the unit is operating.

⚠ IMPORTANT

If a high-efficiency filter is being installed as part of this system to ensure better indoor air quality, the filter must be properly sized. High-efficiency filters have a higher static pressure drop than standard-efficiency glass/foam filters. If the pressure drop is too great, system capacity and performance may be reduced. The pressure drop may also cause the limit to trip more frequently during the winter and the indoor coil to freeze in the summer, resulting in an increase in the number of service calls.

Before using any filter with this system, check the specifications provided by the filter manufacturer against the data given in the appropriate Lennox Product Specifications bulletin. Additional information is provided in Service and Application Note ACC-00-2 (August 2000).

TABLE 2

Furnace Cabinet Width	Filter Size mm (in) and Quantity	
	Side Return	Bottom Return
A - 338 (14-1/2")	406 X 635 X 25 1 (16 X 25 X 1)	356 X 635 X 25 1 (14 X 25 X 1)
B - 446 (17-1/2")	406 X 635 X 25 1 (16 X 25 X 1)	406 X 635 X 25 1 (16 X 25 X 1)
C - 533 (21")	405 X 635 X 25 1 (16 X 25 X 1)	508 X 635 X 25 1 (20 X 25 X 1)
D - 622 (24-1/2")	405 X 635 X 25 2 (16 X 25 X 1)	610 X 635 X 25 1 (24 X 25 X 1)

Duct System

Use industry-approved standards to size and install the supply and return air duct system. This will result in a quiet and low-static system that has uniform air distribution.

NOTE - Do not operate the furnace in the heating mode with an external static pressure that exceeds 125Pa (0.5" w.c.) Higher external static pressures may cause erratic limit operation.

Supply Air Plenum

If the furnace is installed without a cooling coil, a removable access panel must be installed in the supply air duct. The access panel should be large enough to permit inspection (either by smoke or reflected light) of the heat exchanger for leaks after the furnace is installed. The furnace access panel must always be in place when the furnace is operating and it must not allow leaks into the supply air duct system.

TABLE 3

Unit Capacity	Minimum Number of Outlets
ML180UH070AP36A	5
ML180UH090AP48B	7
ML180UH110AP36C	8
ML180UH110AP60C	9
ML180UH135AP60D	10

NOTE - The number of outlets was calculated for the factory set heating speed tap.

Return Air Plenum

NOTE - Return air must not be drawn from a room where this furnace, or any other gas-fueled appliance (i.e., water heater), or carbon monoxide producing device (i.e., wood fireplace) is installed.

When return air is drawn from a room, a negative pressure is created in the room. If a gas appliance is operating in a room with negative pressure, the flue products can be pulled back down the vent pipe and into the room. This reverse flow of the flue gas may result in incomplete combustion and the formation of carbon monoxide gas. This toxic gas might then be distributed throughout the house by the furnace duct system.

Venting

The ML180UHA is a fan assisted furnace equipped with an integral mechanical means to either draw or force products of combustion through the combustion chamber and/or heat exchanger. When installed in the vertical position and vented vertically, the furnace operates with a non-positive vent stack pressure. When installed in the horizontal position and vented vertically, the furnace operates with a positive stack pressure.

⚠ IMPORTANT

The ML180UH is certified for horizontal installation but **DO NOT** vent flue horizontally. The ML180UH furnace is not certified for horizontal venting. See figure 21.

General Venting Requirements

A 102 mm (4 in.) diameter flue transition is factory-installed on the combustion air inducer outlet of all models. **Figure 14 shows the combustion air inducer as shipped from the factory.** Refer to the current edition of the Australian Gas Installation Code (AS/NZS5601) and instructions in this manual for proper sizing an installation of the venting system

When flues are terminated vertically, an AGA approved cowl must be used.

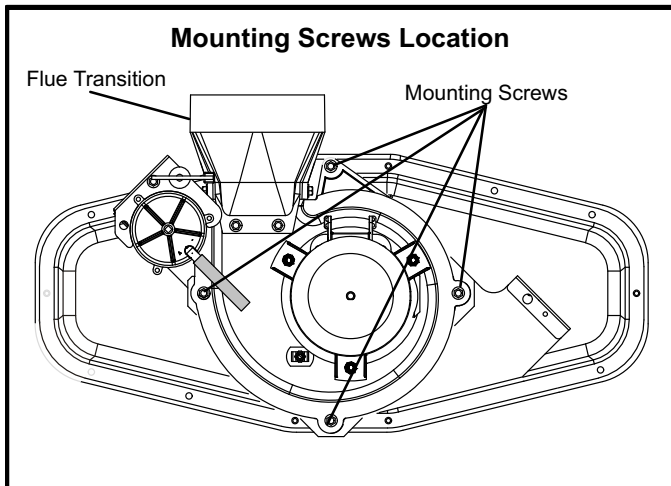

FIGURE 13

If necessary, reposition the combustion air inducer, pressure switch and/or make-up box as needed per the following steps. See figures 14 through 20.

- 1 - Remove the four mounting screws (figure 13) which secure the combustion air inducer / pressure switch assembly to the orifice plate. Lift the inducer assembly and rotate it 90 degrees clockwise or counterclockwise to either the 3 o'clock position or to 9 o'clock position. Re-secure with four screws. Gasket should be left in place.

- 2 - Use tin snips to cut preferred opening on the cabinet for repositioning the flue outlet. Use the cut-out piece as a cover plate to patch unused opening on cabinet.

Upflow Position

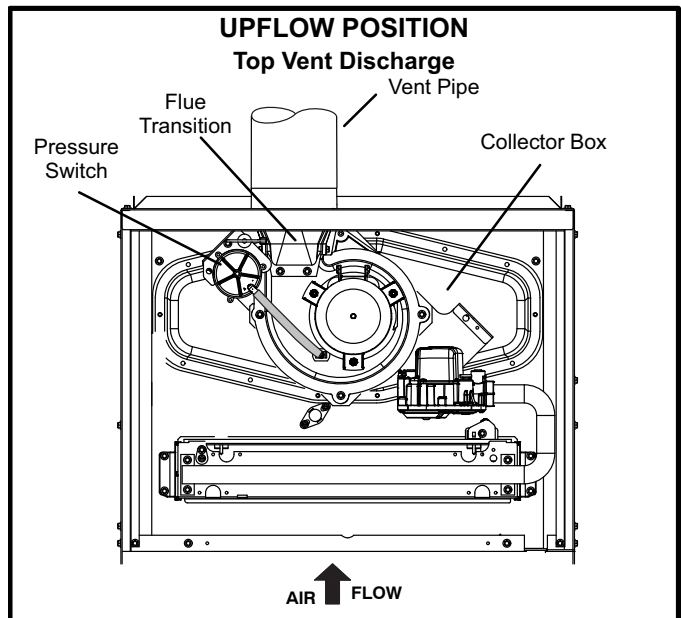

FIGURE 14

⚠ IMPORTANT

The unit will not vent properly with the flue transition pointed down in the 6 o'clock position. The combustion air inducer may be rotated clockwise or counterclockwise by 90° to allow for top or side vent discharge in all applications. When the unit is installed, the flue transition must be in the 9 o'clock, 12 o'clock or 3 o'clock position.

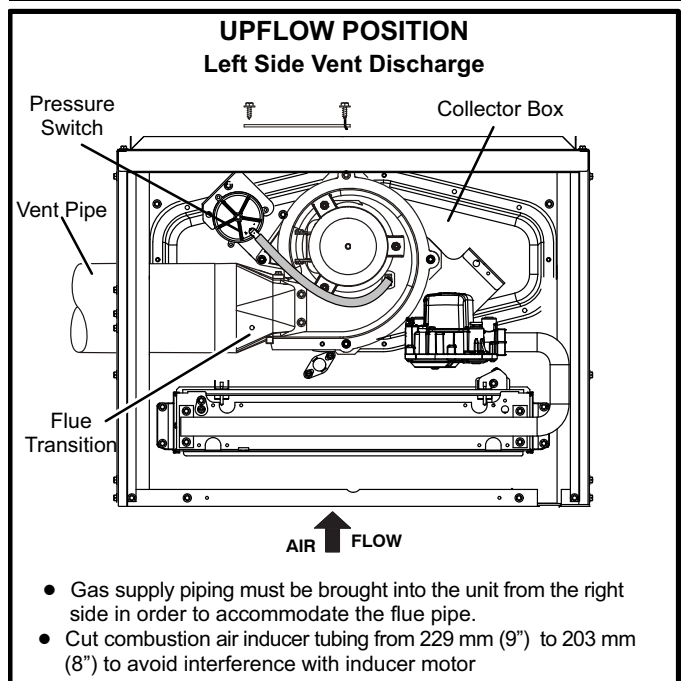

FIGURE 15

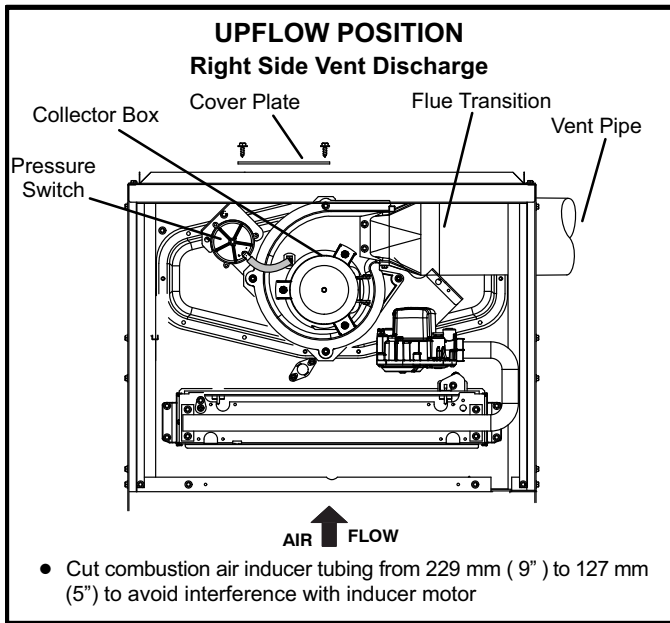

FIGURE 16

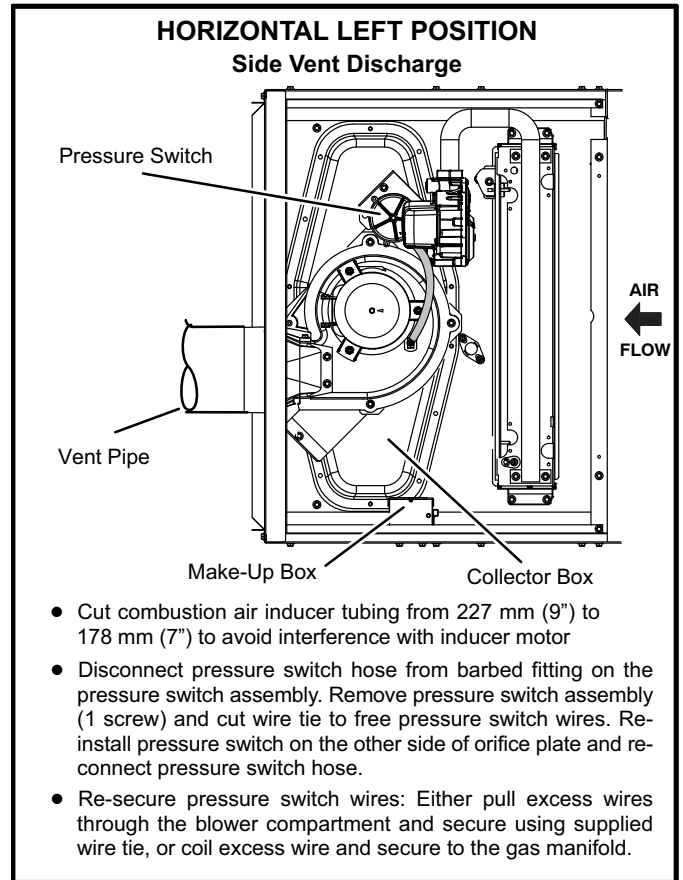

FIGURE 18

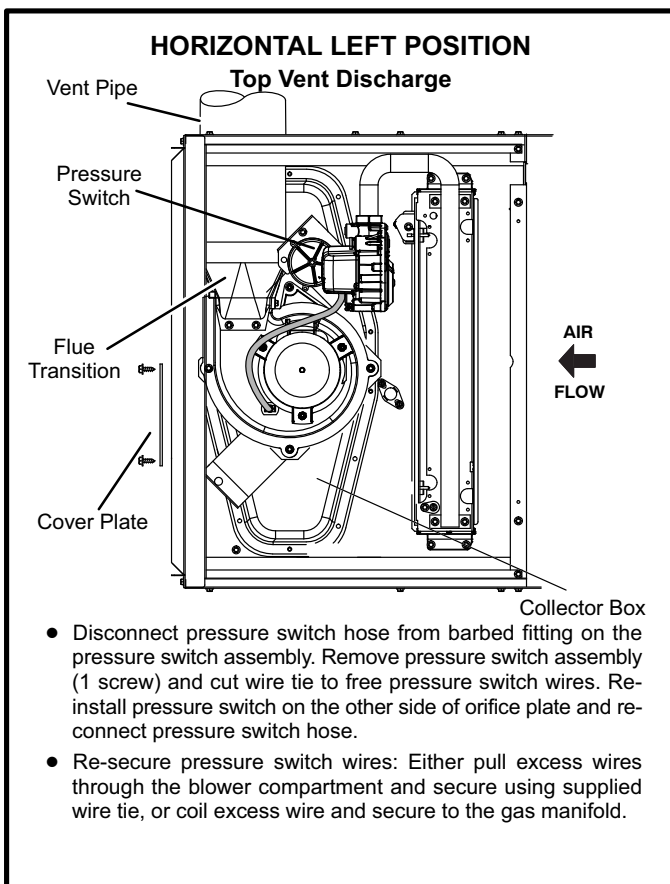

FIGURE 17

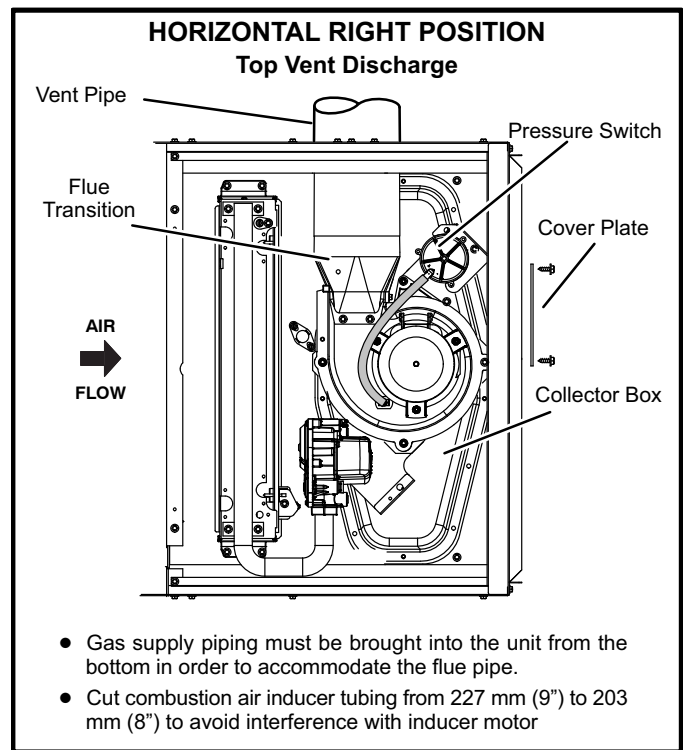

FIGURE 19

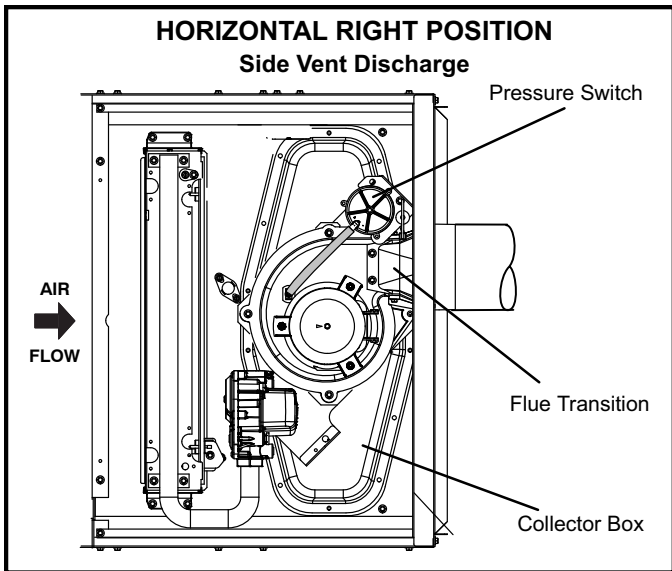

FIGURE 20

⚠ IMPORTANT
Do not use an unlined masonry chimney as the flue for this appliance.

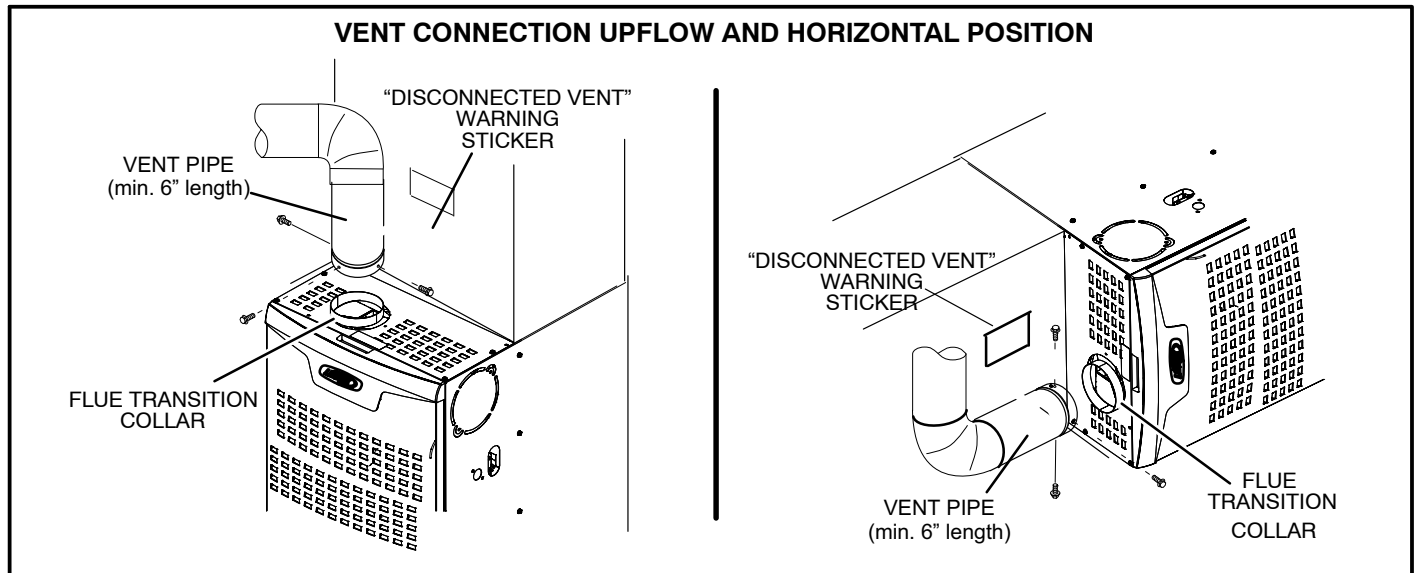

FIGURE 21

Gas Piping

Refer to the current edition of the Australian Gas Installation Code (AS/NZS5601) for gas piping requirements and gas pipe sizing tables.

Gas supply piping should not allow more than 125 Pa (0.5”W.C.) drop in pressure between gas meter and unit. Supply gas pipe must not be smaller than unit gas connection.

⚠ CAUTION
If a flexible gas connector is required or allowed by the authority that has jurisdiction, black iron pipe shall be installed at the gas valve and extend outside the furnace cabinet. The flexible connector can then be added between the black iron pipe and the gas supply line.

Gas Supply

- 1 - This unit is shipped standard for left or right side installation of gas piping (or top entry in horizontal applications). Connect the gas supply to the piping assembly.
- 2 - When connecting the gas supply piping, consider factors such as length of run, number of fittings, and furnace rating to avoid excessive pressure drop.
- 3 - The gas piping must not run in or through air ducts, clothes chutes, gas vents or chimneys, dumb waiters, or elevator shafts.
- 4 - The piping should be sloped 6.4 mm (1/4 in) per 4.57 m (15 ft.) upward toward the meter from the furnace. The piping must be supported at proper intervals every 2.44 to 3.01 m (8 to 10 ft) with suitable hangers or straps. Install a drip leg in vertical pipe runs to the unit.

- 5 - A 3 mm (1/8") N.P.T. plugged tap or pressure port is located on the gas valve to facilitate test gauge connection. See figure 27.
- 6 - In some localities, codes may require the installation of a manual main shut-off valve and union (furnished by the installer) external to the unit. The union must be of the ground joint type.

⚠ IMPORTANT

Compounds used on threaded joints of gas piping must be resistant to the actions of liquefied petroleum gases.

NOTE - If emergency shutoff is necessary, shut off the main manual gas valve and disconnect main power to the furnace. The installer should properly label these devices.

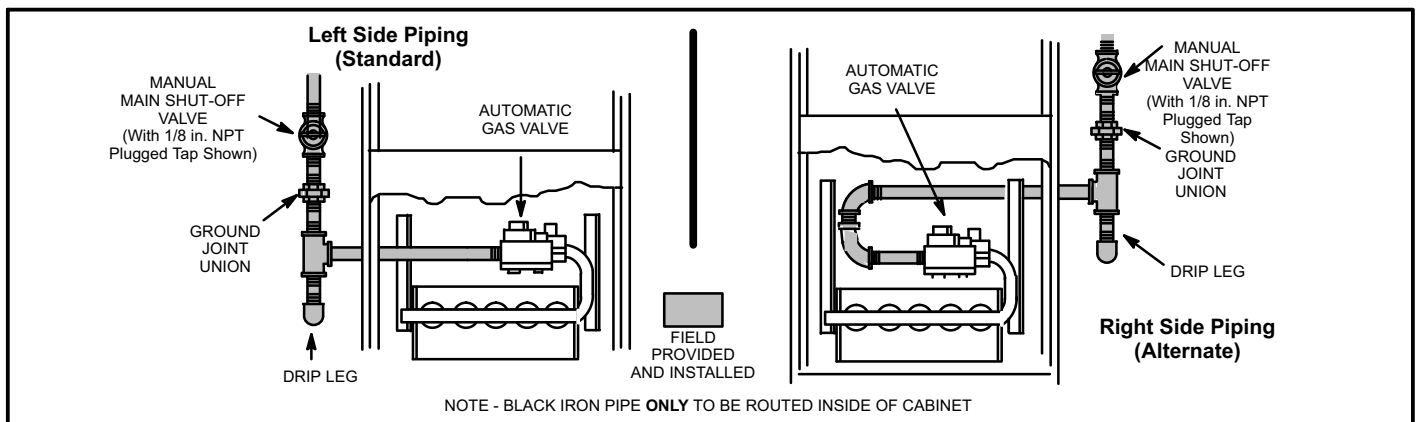

FIGURE 22

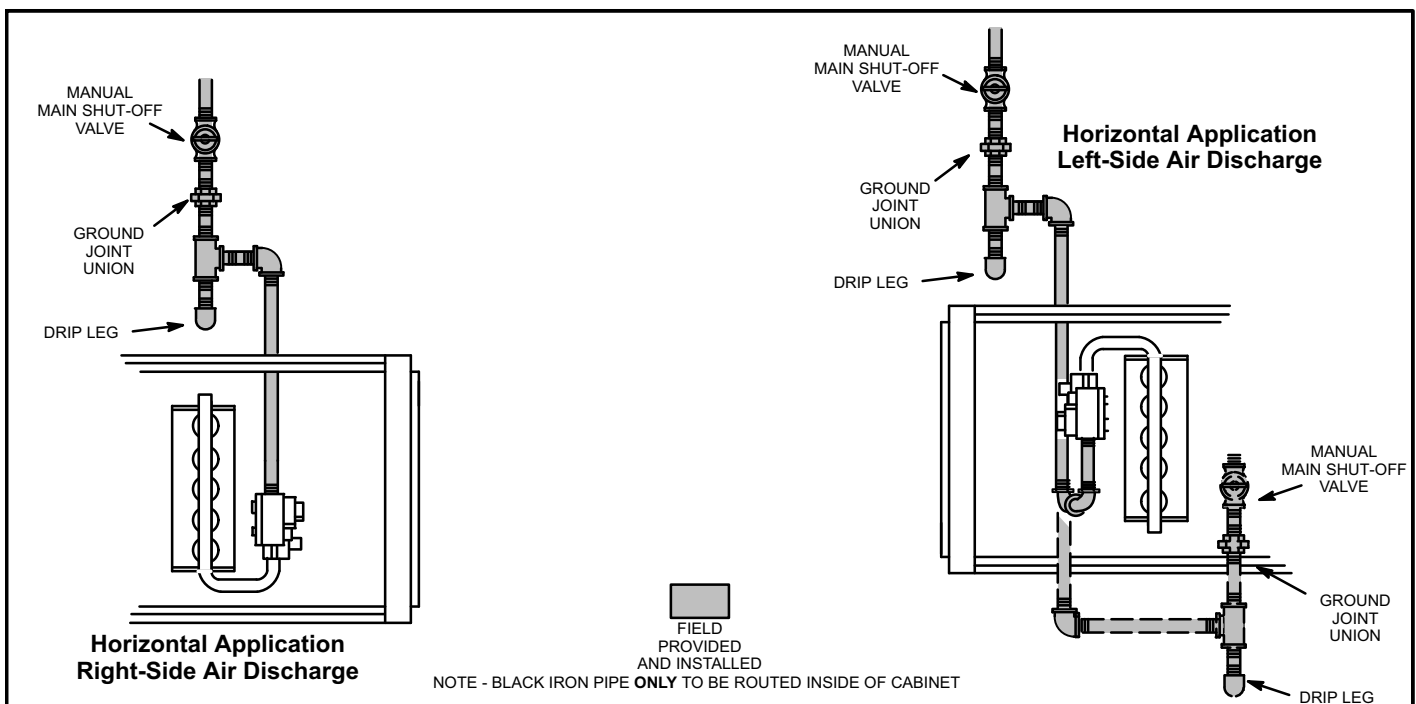

FIGURE 23

Leak Check

After gas piping is completed, carefully check all piping connections (factory- and field-installed) for gas leaks. Use a leak detecting solution or other preferred means.

NOTE - If emergency shutoff is necessary, shut off the main manual gas valve and disconnect the main power to the furnace. The installer should properly label these devices.

⚠ CAUTION

Some soaps used for leak detection are corrosive to certain metals. Carefully rinse piping thoroughly after leak test has been completed. Do not use matches, candles, flame or other sources of ignition to check for gas leaks.

The furnace must be isolated by closing its individual manual shut-off valve and disconnecting from the gas supply system during any pressure testing of the gas supply system at pressures greater than 3.48 kPa (1/2 psig, 14 inches w.c.).

⚠ IMPORTANT

When testing pressure of gas lines, gas valve must be disconnected and isolated. See figure 24. Gas valves can be damaged if subjected to pressures greater than 1/2 psig (3.48 kPa, 14 inches w.c.).

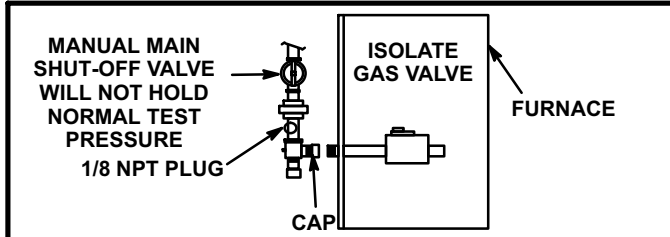

FIGURE 24

Electrical

⚠ CAUTION

Electrostatic discharge can affect electronic components. Take precautions to neutralize electrostatic charge by touching your hand and tools to metal prior to handling the control.

A power wiring harness is shipped with each ML180UHA furnace. An IEC receptacle is provided on the right side of the unit. Plug the harness into the IEC receptacle and into a properly sized wall plug.

Refer to figure 26 schematic wiring diagram.

- 1 - Ensure that power connection point is located with 2m of furnace.

- 2 - Holes are on both sides of the furnace cabinet to facilitate thermostat wiring.
- 3 - Before connecting the thermostat wiring, check to make sure the wires will be long enough for servicing at a later date. Remove the blower access panel to check the length of the wire.
- 4 - Complete the wiring connections to the equipment. Use the provided unit wiring diagram shown in figure 26. 18-gauge wire or larger that is suitable for Class II rating for thermostat connections.
- 5 - Electrically ground the unit according to local codes.
NOTE - The ML180UHA furnace contains electronic components that are polarity sensitive. Make sure that the furnace is wired correctly and is properly grounded.
- 6 - One line voltage "EAC" spade terminal is provided on the furnace control board. Any electronic air cleaner rated up to one amp can be connected to this terminal with the neutral leg of the circuit being connected to one of the provided neutral terminals. See figure 25 for control board configuration. This terminal is energized when the indoor blower is operating.
- 7 - One line voltage "HUM" spade terminal is provided on the furnace control board. Any humidifier rated up to one amp can be connected to this terminal with the neutral leg of the circuit being connected to one of the provided neutral terminals. See figure 25 for control board configuration. This terminal is energized in the heating mode when the combustion air inducer is operating.
- 8 - Install the room thermostat according to the instructions provided with the thermostat. See figure 26 for thermostat designations. If the furnace is being matched with a heat pump, refer to the instruction packaged with the dual fuel thermostat.

Indoor Blower Speeds

- 1 - When the thermostat is set to "FAN ON," the indoor blower will run continuously on the heating speed when there is no cooling or heating demand.
- 2 - When the ML180UHA is running in the heating mode, the indoor blower will run on the heating speed.
- 3 - When there is a cooling demand, the indoor blower will run on the cooling speed.

Generator Use - Voltage Requirements

The following requirements must be kept in mind when specifying a generator for use with this equipment:

- The furnace requires 240 volts \pm 10%.
- The furnace operates at 50 Hz \pm 5% .
- The furnace integrated control requires both polarity and proper ground. Both polarity and proper grounding should be checked before attempting to operate the furnace on either permanent or temporary power.
- Generator should have a wave form distortion of less than 5% THD (total harmonic distortion)

**INTEGRATED CONTROL
(Automatic Hot Surface Ignition System)**

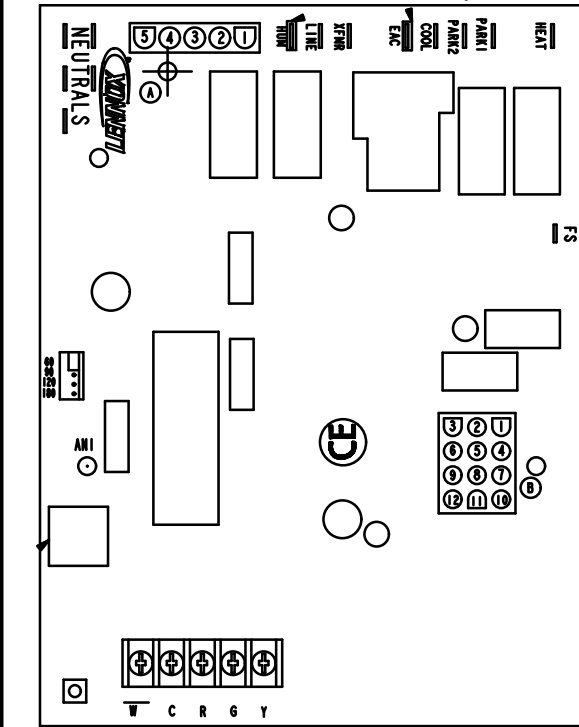

TERMINAL DESIGNATIONS

- HUM - Humidifier 240VAC
- LINE - Input 240VAC
- XFMR - Transformer 240VAC
- EAC - Electronic Air Cleaner 240VAC
- COOL - Cool Speed 240VAC
- PARK1, PARK2 - Dead terminals for alternate speed taps
- NEUTRALS - Neutral terminals 240VAC
- HEAT - Heating Speed 240VAC
- FS - Flame Sense

FIGURE 25

ML180UA Schematic Wiring Diagram

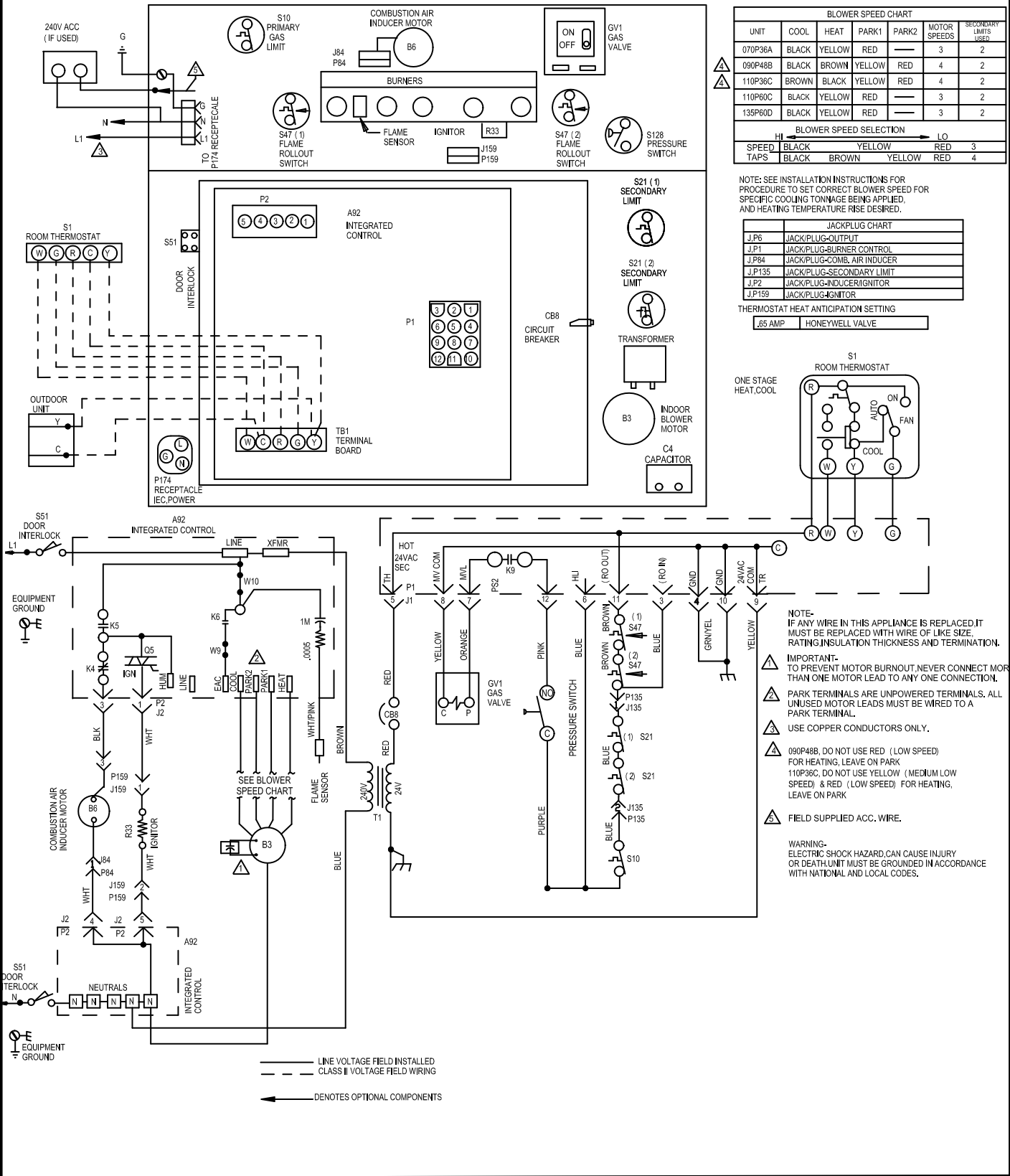

FIGURE 26

Unit Start-Up

FOR YOUR SAFETY READ BEFORE LIGHTING

⚠ WARNING

Do not use this furnace if any part has been underwater. A flood-damaged furnace is extremely dangerous. Attempts to use the furnace can result in fire or explosion. Immediately call a qualified service technician to inspect the furnace and to replace all gas controls, control system parts, and electrical parts that have been wet or to replace the furnace, if deemed necessary.

⚠ WARNING

If overheating occurs or if gas supply fails to shut off, shut off the manual gas valve to the appliance before shutting off electrical supply.

⚠ CAUTION

Before attempting to perform any service or maintenance, turn the electrical power to unit OFF at disconnect switch.

BEFORE LIGHTING smell all around the appliance area for gas. Be sure to smell next to the floor because some gas is heavier than air and will settle on the floor.

The gas valve on the ML180UHA unit will be equipped with a gas control switch. Use only your hand to move the switch. Never use tools. If the switch will not turn or if the control switch will not move by hand, do not try to repair it.

Placing the furnace into operation:

ML180UHA units are equipped with an automatic ignition system. Do not attempt to manually light burners on these furnaces. Each time the thermostat calls for heat, the burners will automatically light. The ignitor does not get hot when there is no call for heat on units with an automatic ignition system.

⚠ WARNING

If you do not follow these instructions exactly, a fire or explosion may result causing property damage, personal injury or death.

Gas Valve Operation

- 1 - **STOP!** Read the safety information at the beginning of this section.
- 2 - Set the thermostat to the lowest setting.
- 3 - Turn off all electrical power to the unit.
- 4 - This furnace is equipped with an ignition device which automatically lights the burners. Do **not** try to light the burners by hand.
- 5 - Remove the upper access panel.
- 6 - Move lever on gas valve to **OFF**. See figure 27.
- 7 - Wait five minutes to clear out any gas. If you then smell gas, **STOP!** Immediately call your gas supplier from a neighbor's phone. Follow the gas supplier's instructions. If you do not smell gas go to next step.

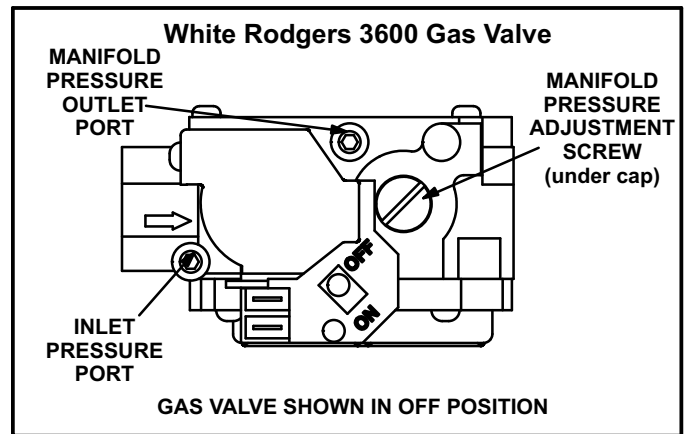

FIGURE 27

- 8 - Move lever on gas valve to **ON**. See figure 27.
 - 9 - Replace the upper access panel.
 - 10 - Turn on all electrical power to the unit.
 - 11 - Set the thermostat to desired setting.
- NOTE - When unit is initially started, steps 1 through 11 may need to be repeated to purge air from gas line.*
- 12 - If the appliance will not operate, follow the instructions "Turning Off Gas to Unit" and call your service technician or gas supplier.

Turning Off Gas to Unit

- 1 - Set the thermostat to the lowest setting.
- 2 - Turn off all electrical power to the unit if service is to be performed.
- 3 - Remove the upper access panel.

- 4 - Move lever on gas valve to **OFF**. See figure 27.
- 5 - Replace the upper access panel.

Failure To Operate

If the unit fails to operate, check the following:

- 1 - Is the thermostat calling for heat?
- 2 - Are access panels securely in place?
- 3 - Is the main disconnect switch closed?
- 4 - Is there a blown fuse or tripped circuit breaker?
- 5 - Is the filter dirty or plugged? Dirty or plugged filters will cause the limit control to shut the unit off.
- 6 - Is gas turned on at the meter?
- 7 - Is the manual main shut-off valve open?
- 8 - Is the internal manual shut-off valve open?
- 9 - Is the unit ignition system in lock out? If the unit locks out again, call the service technician to inspect the unit for blockages.
- 10 - Is pressure switch closed? Obstructed flue will cause unit to shut off at pressure switch. Check flue and outlet for blockages. If no blockage is found call the service technician.
- 11 - Are flame rollout switches tripped? If flame rollout switches are tripped, call the service technician for inspection.

Heating Sequence Of Operation

(follow steps below or see Figure 26 for more detail)

- 1 - When thermostat calls for heat, combustion air blower starts.
- 2 - Combustion air pressure switch proves blower operation. Switch is factory-set and requires no adjustment.
- 3 - After a 15-second prepurge, the hot surface ignitor energizes.
- 4 - After a 20-second ignitor warm-up period, the gas valve solenoid opens. A 4-second trial for ignition period begins.
- 5 - Gas is ignited, flame sensor proves the flame, and the combustion process continues.
- 6 - If flame is not detected after first ignition trial, the ignition control will repeat steps 3 and 4 four more times before locking out the gas valve ("WATCHGUARD" flame failure mode). The ignition control will then automatically repeat steps 1 through 6 after 60 minutes.
- 7 - To interrupt the 60-minute "WATCHGUARD" period, move thermostat from "Heat" to "OFF" then back to "Heat." Heating sequence then restarts at step 1.

Gas Pressure Adjustment

Gas Flow

NOTE - The manufacturer recommended gas orifice size is 1.60 mm for natural gas and 0.86 mm for L.P.

To check for proper flow to combustion chamber, determine MJ/Hr input from appliance rating plate. Divide this input rating by the MJ/Hr per cubic meter of available gas. Result is the required number of cubic meter per hour. Determine the flow of gas through the gas meter for two minutes and multiply by 30 to get the hourly flow of gas.

⚠️ IMPORTANT

The White Rodgers 36G24 gas valve (figure 27) is equipped with pressure posts for measuring supply and manifold pressures. The posts provide built-in 7.9mm (5/16") hose connections and have an integral 2.4mm (3/32") Allen-head screw. Rotate the screw counterclockwise one full turn to permit pressure measurement. Reseat the screw (rotate one full turn clockwise) after measurements have been taken to prevent gas leakage.

Use pressure measurement kit 69M1701 to connect 7.9mm (5/16") pressure post on gas valve to 6.4mm (1/4") hose off the manometer.

Line Pressure Measurement

- 1 - Check the gas line pressure with the unit firing at maximum rate. See table 5 for maximum and minimum line pressures.

After the line pressure has been checked and adjusted, check the manifold pressure per table 5. See figure 27 for the location of the manifold pressure adjustment screw.

Manifold Pressure Measurement

- 1 - Connect the outlet side of the gas to a manometer to measure manifold pressure.
- 2 - Start unit and allow 5 minutes for unit to reach steady state.
- 3 - While waiting for the unit to stabilize, observe the flame. Flame should be stable and should not lift from burner. Natural gas should burn blue.
- 4 - After allowing unit to stabilize for 5 minutes, record manifold pressure and compare to value given in table 5.
- 5 - Shut unit off and remove manometer as soon as an accurate reading has been obtained. Take care to replace pressure tap plug.
- 6 - Start unit and perform leak check. Seal leaks if found.

Proper Combustion

Furnace should operate a minimum 15 minutes with correct manifold pressure and gas flow rate before checking combustion. Take combustion sample beyond the flue outlet and compare to the tables below. **The maximum carbon monoxide reading should not exceed 100 ppm.**

TABLE 4

Unit	CO ₂ % For Nat	CO ₂ % For L.P.
-070	6.3 - 7.8	7.0 - 9.0
-090		
-110		
-135		

High Altitude

The manifold pressure may require adjustment and combustion air pressure switch may need replacing to ensure proper combustion at higher altitudes. Refer to table 5 for manifold pressure and table 6 for pressure switch change and gas conversion kits.

! IMPORTANT

For safety, shut unit off and remove manometer as soon as an accurate reading has been obtained. Take care to replace pressure tap plug.

TABLE 5
Manifold Pressure Settings at all Altitudes

Model Input Size	Gas	0-610 m* (0-2000 ft)	611-914 m* (2001-3000 ft.)	915-1219 m* (3001-4000 ft)	1220-1524 m* (4001-5000 ft.)	1525-1981 m* (5001-6500 ft)	Line Pressure kPa	
							Min	Max
All Models	Nat	0.87	0.72	0.67	0.62	0.87	1.13	3.23
	LP/propane	2.30	2.30	2.19	2.12	2.30	2.75	3.23

* See table 6 for proper high altitude gas conversion kit.

TABLE 6
Pressure Switch and Gas Conversion Kits at all Altitudes

Model Input Size	High Altitude Pressure Switch Kit			High Altitude Natural Gas Burner Orifice Kit	Natural Gas to LP/Propane Gas Change over Kit		LP/Propane to Natural Gas Change over Kit
	0-610 m (0-2000 ft)	611-1219 m (2001-4000 ft)	1220-1981 m (4001-6500 ft)	1525-1981 m (5001-6500 ft)	0-1524 m (0-5000 ft)	1525-1981 m (5001-6500 ft)	1-1524 m (1-5000 ft)
070	No Change	80W51	80W56	73W37	11K15	97W04	96W95
090		80W51	80W56				
110		80W51	80W56				
135		No Change	80W51				

NOTE - A natural to L.P. propane gas changeover kit is necessary to convert this unit. Refer to the changeover kit installation instruction for the conversion procedure.

Other Unit Adjustments

Primary and Secondary Limits

The primary limit is located on the heating compartment vestibule panel. The secondary limits (if equipped) are located in the blower compartment, attached to the back side of the blower. These auto reset limits are factory-set and require no adjustment.

Flame Rollout Switches

This manually reset switches are located on the top of the burner box.

Pressure Switch

The pressure switch is located in the heating compartment adjacent to the combustion air inducer. The switch checks for proper combustion air inducer operation before allowing ignition trial. The switch is factory-set and requires no adjustment.

Temperature Rise

After the furnace has been started, and supply and return

air temperatures have been allowed to stabilize, check the temperature rise. If necessary, adjust the blower speed to maintain the temperature rise within the range shown on the unit nameplate. Increase the blower speed to decrease the temperature. Decrease the blower speed to increase the temperature rise. Failure to adjust the temperature rise may cause erratic limit operation.

Fan Control

The fan-on time of 30 seconds is not adjustable. The heat fan-off delay (amount of time that the blower operates after the heat demand has been satisfied) may be adjusted by changing the jumper position across the five pins on the integrated control. The unit is shipped with a factory fan-off delay setting of 60 seconds. The fan-off delay affects comfort and is adjustable to satisfy individual applications. Adjust the fan-off delay to achieve a supply air temperature between 32°C and 43°C at the moment that the blower is de-energized. Longer off delay settings provide lower return air temperatures; shorter settings provide higher return air temperatures. See figure 28.

HEAT FAN-OFF TIME IN SECONDS

JUMPER POSITION		HEAT OFF DELAY
PIN1	PIN2	60
PIN2	PIN3	90
PIN3	PIN4	120
PIN4	PIN5	180
NO JUMPER		180

To adjust fan-off timing, reposition jumper across pins to achieve desired setting.

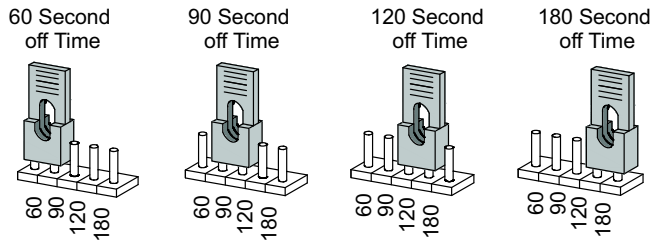

FIGURE 28

NOTE - Do not secure the electrical conduit directly to the air ducts or structure.

Electrical

- 1 - Check all wiring for loose connections.
- 2 - Check for the correct voltage at the furnace (furnace operating). Correct voltage is 240VAC \pm 10%.
- 3 - Check amp-draw on the blower motor with inner blower panel in place.

Unit Nameplate _____ Actual _____

Blower Speeds

Follow the steps below to change the blower speeds.

- 1 - Turn off electrical power to furnace.
- 2 - Remove blower access panel.
- 3 - Disconnect existing speed tap at integrated control speed terminal.

See unit *Product Specifications bulletin* for indoor blower data.

NOTE - Termination of any unused motor leads must be insulated.

- 4 - Place unused blower speed tap on integrated control "PARK" terminal or insulate.
- 5 - Refer to blower speed selection chart on unit wiring diagram for desired heating or cooling speed. See Blower performance data beginning on the next page.
- 6 - Connect selected speed tap at integrated control speed terminal.
- 7 - Resecure blower access panel.
- 8 - Turn on electrical power to furnace.
- 9 - Recheck temperature rise.

Electronic Ignition

The integrated control has an added feature of an internal Watchguard control. The feature serves as an automatic reset device for integrated control lockout caused by ignition failure. This type of lockout is usually due to low gas line pressure. After one hour of continuous thermostat demand for heat, the Watchguard will break and remake thermostat demand to the furnace and automatically reset the integrated control to begin the ignition sequence.

Service

⚠ WARNING

ELECTRICAL SHOCK, FIRE, OR EXPLOSION HAZARD.

Failure to follow safety warnings exactly could result in dangerous operation, serious injury, death or property damage.

Improper servicing could result in dangerous operation, serious injury, death, or property damage.

Before servicing, disconnect all electrical power to furnace.

When servicing controls, label all wires prior to disconnecting. Take care to reconnect wires correctly. Verify proper operation after servicing.

At the beginning of each heating season, a qualified technician should check the system as follows:

Blower

Check the blower wheel for debris and clean if necessary. The blower motors are prelubricated for extended bearing life. No further lubrication is needed.

⚠ WARNING

The blower access panel must be securely in place when the blower and burners are operating. Gas fumes, which could contain carbon monoxide, can be drawn into living space resulting in personal injury or death.

Filters

All ML180UHA filters are installed external to the unit. Filters should be inspected monthly. Clean or replace the filters when necessary to ensure that the furnace operates properly. Replacement filters must be rated for high velocity airflow. Table 2 lists recommended filter sizes.

Flue And Chimney

- 1 - Check flue pipe, chimney and all connections for tightness and to make sure there is no blockage.
- 2 - Check unit for proper draft.

Electrical

- 1 - Check all wiring for loose connections.
- 2 - Check for the correct voltage at the furnace (furnace operating). Correct voltage is 240VAC \pm 10%.
- 3 - Check amp-draw on the blower motor with inner blower panel in place.

Unit Nameplate _____ Actual _____

Cleaning the Burners

NOTE - Use papers or protective covering in front of the furnace during cleaning.

- 1 - Turn off both electrical and gas power supplies to furnace.
- 2 - Label the wires from gas valve, rollout switches, primary limit switch and make-up box then disconnect them.

- 3 - Disconnect gas supply piping. Remove the screw securing the burner box cover and remove cover. Remove the four screws securing the burner manifold assembly to the vestibule panel and remove the assembly from the unit.
- 4 - To clean burners, run a vacuum cleaner with a soft brush attachment over the face of burners. Visually inspect inside the burners and crossovers for any blockage

caused by foreign matter. Remove any blockage. Figure 29 shows burner detail.

- 5 - Reinstall burner box, manifold assembly and burner box cover.
- 6 - Re-install gas supply and turn on electrical power to furnace.

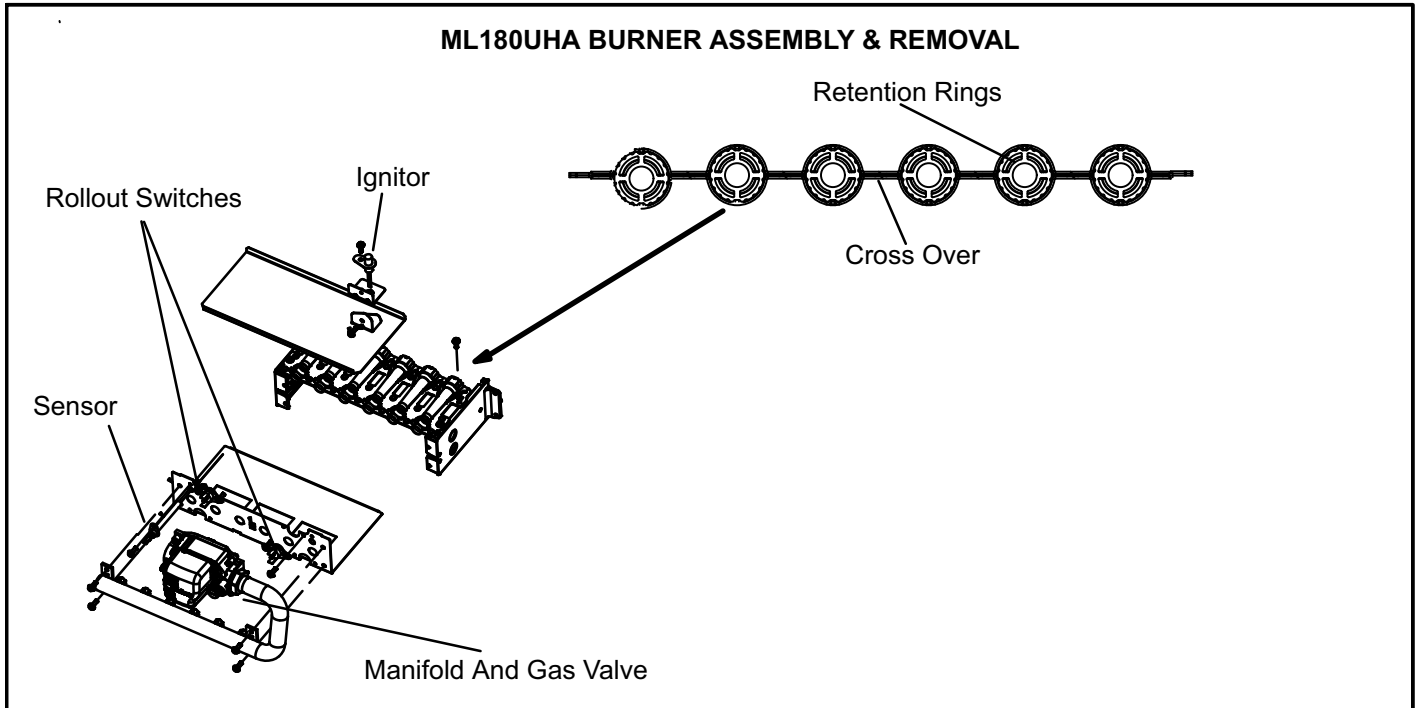

FIGURE 29

Repair Parts List

The following repair parts are available through independent Lennox dealers. When ordering parts, include the complete furnace model number listed on the CSA International nameplate -- Example: ML180UH070AP36A-01. **All service must be performed by a licensed professional installer (or equivalent), service agency, or gas supplier.**

Cabinet Parts

- Upper access panel
- Blower panel
- Top cap

Control Panel Parts

- Transformer
- Integrated control
- Door interlock switch
- Circuit breaker

Blower Parts

- Blower wheel
- Blower housing
- Motor
- Motor mounting frame
- Motor capacitor
- Blower housing cutoff plate

Heating Parts

- Flame sensor
- Heat exchanger assembly
- Gas manifold
- Combustion air inducer
- Gas valve
- Main burner cluster
- Main burner orifices
- Pressure switch
- Ignitor
- Primary limit control
- Flame rollout switch (s)
- Secondary limit

SPECIFICATIONS

Gas Heating Performance	Model Number	ML180UH070AP36A	ML180UH090AP48B	ML180UH110AP36C
	Australian Gas Association Energy Rating - Stars	3.7	3.7	3.7
	Input - Mj/h	69.6	92.8	116.1
	Output - kW	15.5	20.6	25.8
	Temperature rise range - °C	14 - 31	14 - 31	19 - 36
	Gas Manifold Pressure (kPa) Natural Gas / Propane	0.87 / 2.30	0.87 / 2.30	0.87 / 2.30
High Static - Pa		125	125	125
Connections	Flue connection - mm round	102	102	102
	Gas pipe size IPS	1/2 in.	1/2 in.	1/2 in.
Indoor Blower	Wheel nom. diameter x width - mm	254 x 203	254 x 254	254 x 254
	Motor output - W	248	373	373
	Add-on cooling - kW	7-10.6	7-14.1	7-14.1
	Air Volume Range - L/s	282 - 716	229 - 890	239 - 827
Electrical Data		Voltage 220/240 volts - 50 hertz - 1 phase (less than 10 amps)		
Shipping Data		kg - 1 package 54	63	70

NOTE - Filters and provisions for mounting are not furnished and must be field provided.

SPECIFICATIONS

Gas Heating Performance	Model Number	ML180UH110AP60C	ML180UH135AP60D
	Australian Gas Association Energy Rating - Stars	3.7	3.7
	Input - Mj/h	116.1	139.3
	Output - kW	25.8	31.0
	Temperature rise range - °C	17 - 33	17 - 33
	Gas Manifold Pressure (kPa) Natural Gas / Propane	0.87 / 2.30	0.87 / 2.30
High Static - Pa		125	125
Connections	Flue connection - mm round	102	102
	Gas pipe size IPS	1/2 in.	1/2 in.
Indoor Blower	Wheel nom. diameter x width - mm	292 x 254	279 x 279
	Motor output - W	746	746
	Add-on cooling - kW	14.1-17.6	14.1-17.6
	Air Volume Range - L/s	633 - 1138	602 - 1159
Electrical Data		Voltage 220/240 volts - 50 hertz - 1 phase (less than 10 amps)	
Shipping Data		kg - 1 package 71	79

NOTE - Filters and provisions for mounting are not furnished and must be field provided.