



THIS MANUAL MUST BE LEFT WITH THE OWNER FOR FUTURE REFERENCE

These instructions are intended as a general guide and do not supersede local codes in any way. Consult authorities having jurisdiction before installation.

⚠ WARNING

Improper installation, adjustment, alteration, service or maintenance can cause property damage, personal injury or loss of life.

Installation and service must be performed by a licensed professional HVAC installer (or equivalent) or service agency.

Failure to follow safety warnings and these instructions exactly could result in property damage, dangerous operation, serious injury, or death.

Any additions, changes, or conversions required in order for the appliance to satisfactorily meet the application needs must be made by a licensed professional HVAC installer (or equivalent) using factory-specified parts.

Do not use this system if any part has been under water. A flood-damaged appliance is extremely dangerous. Immediately call a licensed professional HVAC service technician (or equivalent) to inspect the system and to replace all controls and electrical parts that have been wet, or to replace the system, if deemed necessary.

INSTALLATION/OPERATION INSTRUCTIONS

VRA Heat Recovery

VRF SYSTEMS
OUTDOOR UNITS
507451-08
11/2018

⚠ WARNING

Do not change the settings of any protection devices installed in the outdoor unit. If the pressure switch, thermal switch, or other protection device is shorted or forcibly operated, fire or explosion may occur.

Do not use parts other than those specified by Lennox or fire and/or explosion may occur.

⚠ CAUTION

As with any mechanical equipment, contact with sharp sheet metal edges can result in personal injury. Take care while handling this equipment and wear gloves and protective clothing.

⚠ IMPORTANT

The Clean Air Act of 1990 bans the intentional venting of refrigerant (CFC's and HCFC's) as of July 1, 1992. Approved methods of recovery, recycling or reclaiming must be followed. Fines and/or incarceration may be levied for non-compliance.

These units must be installed as part of a matched system as specified in the Product Specifications (EHB) bulletin.

General

The VRA heat recovery outdoor units are matched with up to 63 indoor units to create a VRF (variable refrigerant flow) system that uses HFC-410A refrigerant. Refer to the Product Specification bulletin (EHB) for the proper use of these heat recovery units with matching indoor units, mode selection boxes, branch pipes, line sets and controls.

Shipping and Packing List

Check the components for shipping damage. If you find any damage, immediately contact the last carrier. Package 1 of 1 contains the following:

- 1 - Assembled VRA heat recovery outdoor unit
- 1 - Outdoor unit installation instruction
- 1 - Outdoor unit user's manual
- 1 - Piping accessory package

Safety Requirements

⚠ WARNING

ELECTRICAL SHOCK, FIRE, OR EXPLOSION HAZARD.

Do not touch the unit or the controller if your hands are wet.

Do not operate appliances with an open flame near the unit.

Do not replace a fuse with a fuse of a different rating. Do not attempt to bypass a fuse.

Do not insert your hands, tools or any other item into the air intake or air outlet at either the indoor or outdoor unit.

Do not allow children to operate the system.

Model Number Identification

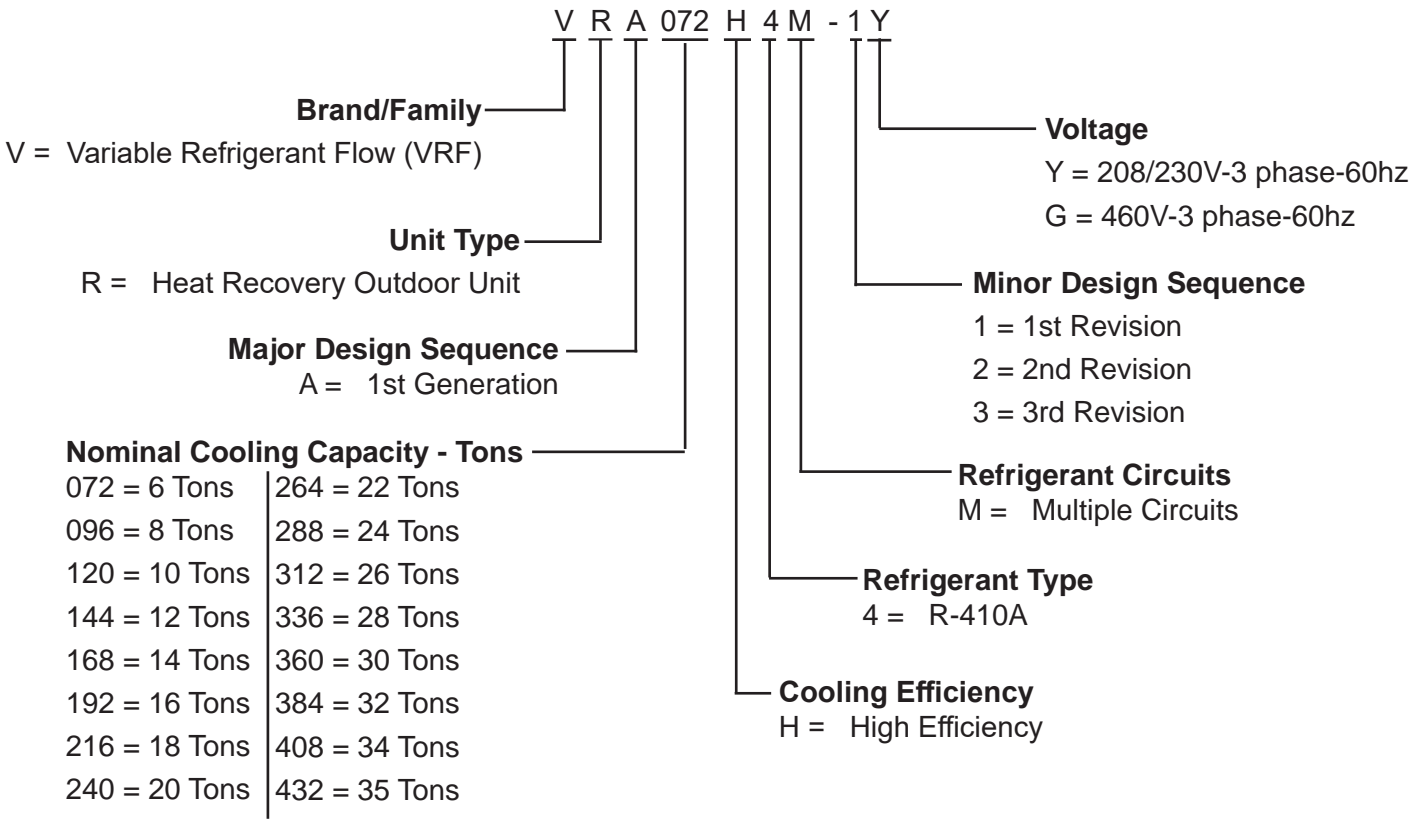

NOTE - Lennox VRF and Lennox Mini-Split products are similar in appearance to each other. Refer to the unit's model number to determine if the unit is a VRF (V) or Mini-Split (M) unit. It is not possible to mix the two types of equipment on any system.

System Piping

⚠ CAUTION

VRF system piping is customized for each installation. The Lennox VRF Selection Software (LVSS) piping report is an engineered design that must be followed. The piping diagram or diagrams included within the LVSS report have been prepared based on the information provided to the Lennox VRF applications department.

When the indicated lengths change from the figures stated within the report, it is imperative that prior to the commencement of the refrigerant pipe work installation, Lennox VRF applications department are informed of these proposed changes.

⚠ CAUTION

Upon receipt of this new information the Lennox VRF applications department will confirm any changes that may be applicable to this installation. If changes are required, a new piping diagram will be produced and will supersede all other previously provided documents.

Failure to provide this information regarding changes to the original design may lead to insufficient capacity, equipment failure, warranty being made void and the refusal to commission the system.

Unit Dimensions - inches (mm)

CORNER WEIGHTS

Model No.	AA		BB		CC		DD		CENTER OF GRAVITY		EE		FF	
	lbs.	kg	lbs.	kg	lbs.	kg	lbs.	kg	in.	mm	in.	mm	in.	mm
VRA072, 096, 120	137	62	152	69	180	82	162	74	26	660	13-7/8	351		
VRA144	124	57	155	71	256	116	205	93	27-1/2	699	11-3/8	289		

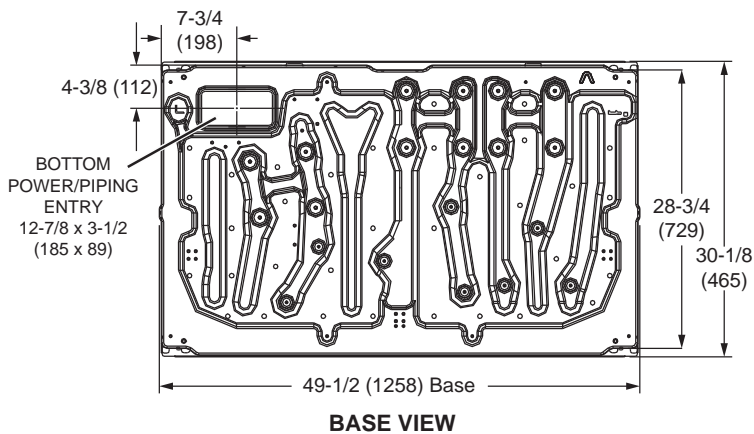
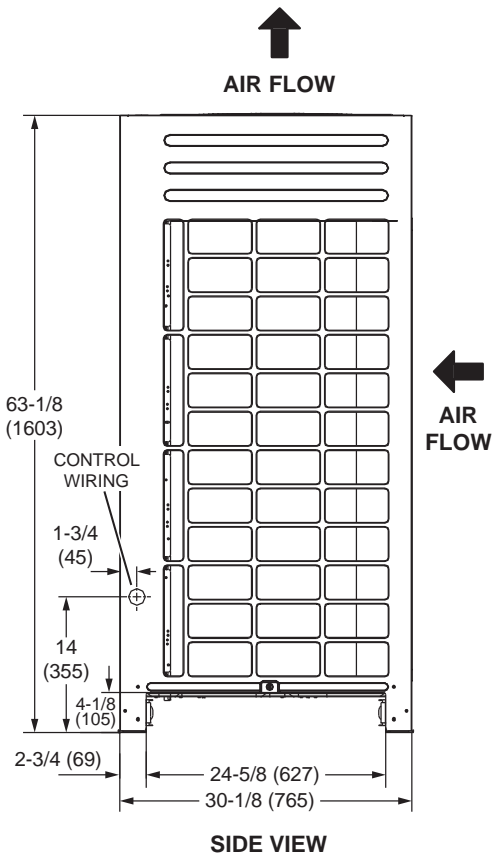
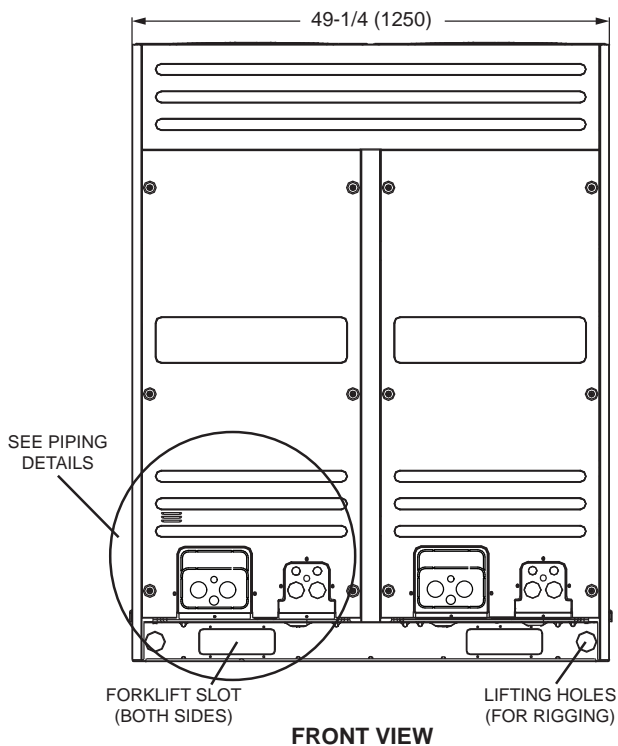
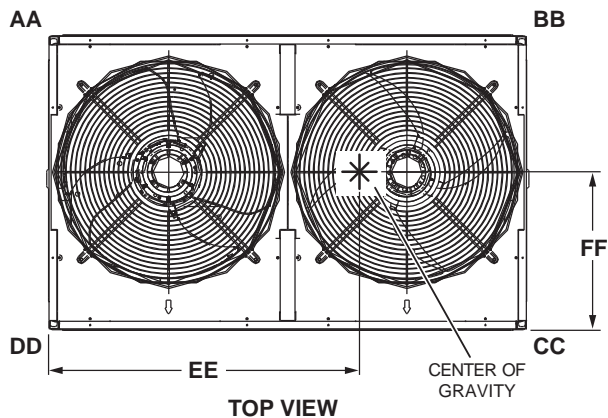

Dimensions - Piping Details - inches (mm)

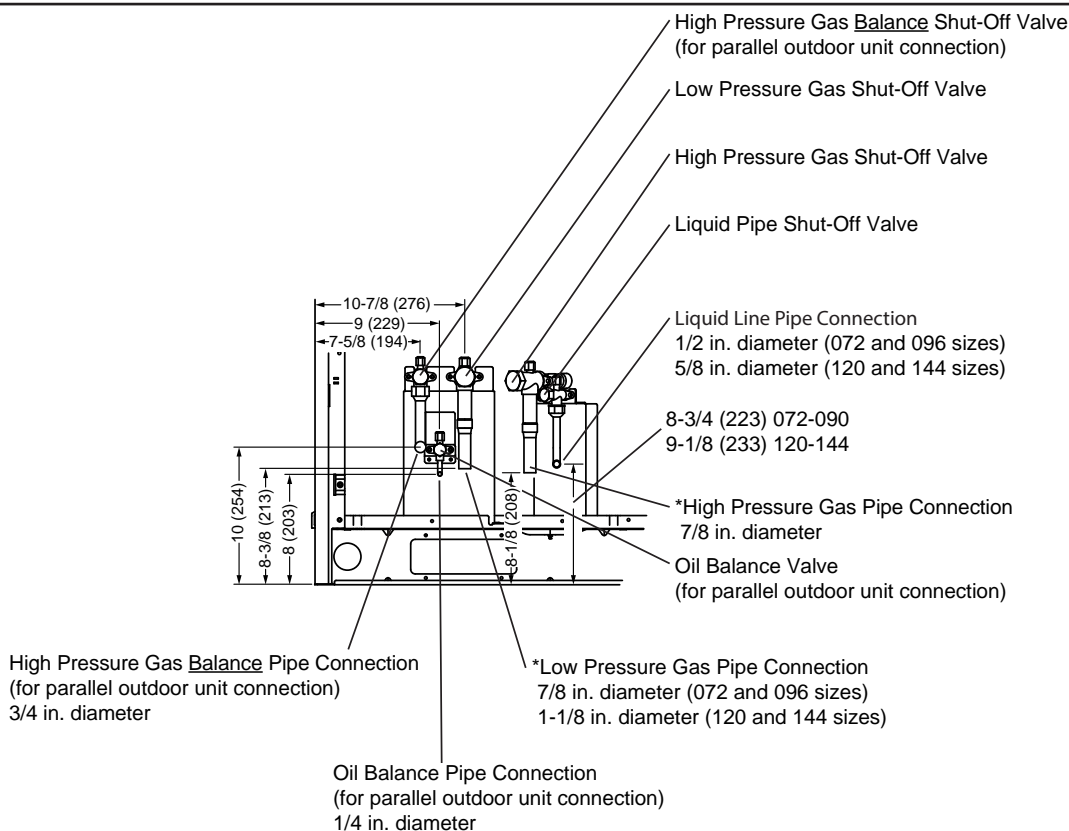

*NOTE - Two 90° Elbows are furnished for Low Pressure and High Pressure Gas Pipe Connections from the front of the unit.

Unit Placement Considerations

⚠ WARNING

Use the provided and specified components when installing equipment. Failure to do so may result in unit falling, water leaking or electrical shocks, causing personal injury or equipment or property damage.

Check stability of unit support. If support is not capable of carrying weight of the unit, unit may fall causing personal injury or equipment damage.

Safely dispose of packing materials, which include nails, wood and other sharp objects, as well as plastic wrapping. Children playing with plastic wrap or bags risk the danger of suffocation.

IMPORTANT!

Exhaust vents from dryers, water heaters and furnaces should be directed away from the outdoor unit. Prolonged exposure to exhaust gases and the chemicals contained within them may cause condensation to form on the steel cabinet and other metal components of the outdoor unit. This will diminish unit performance and longevity.

Outdoor Unit Positioning Considerations

In addition to clearances, the following items should be considered when setting the outdoor unit:

- 2007 EPA Noise Policy. Observe local code adoptions/enforcement as consideration should be used when selecting an outdoor units permanent placement. Sound data for each unit can be found in the Product Specifications Document.
- Glass has a very high level of sound transmission. When possible, do not install the unit directly outside a window.
- Avoid installing the unit in areas exposed to extreme voltage variations (such as factories).
- Install unit level.
- Allow sufficient space around unit for proper operation and maintenance.
- Install the outdoor unit a minimum of 3 feet away from any antenna, power cord (line), radio, telephone, security system, or intercom. Electrical interference and radio frequencies from any of these sources may affect operation.
- Coating Outdoor Coils is recommended in applications installed in coastal regions less than 30 miles inland.

Lifting the Unit

- Do not hold the air inlet grille while lifting the unit. This could result in damage to the cabinet.

- Do not touch the fan blades with your hands or other objects while lifting the unit.

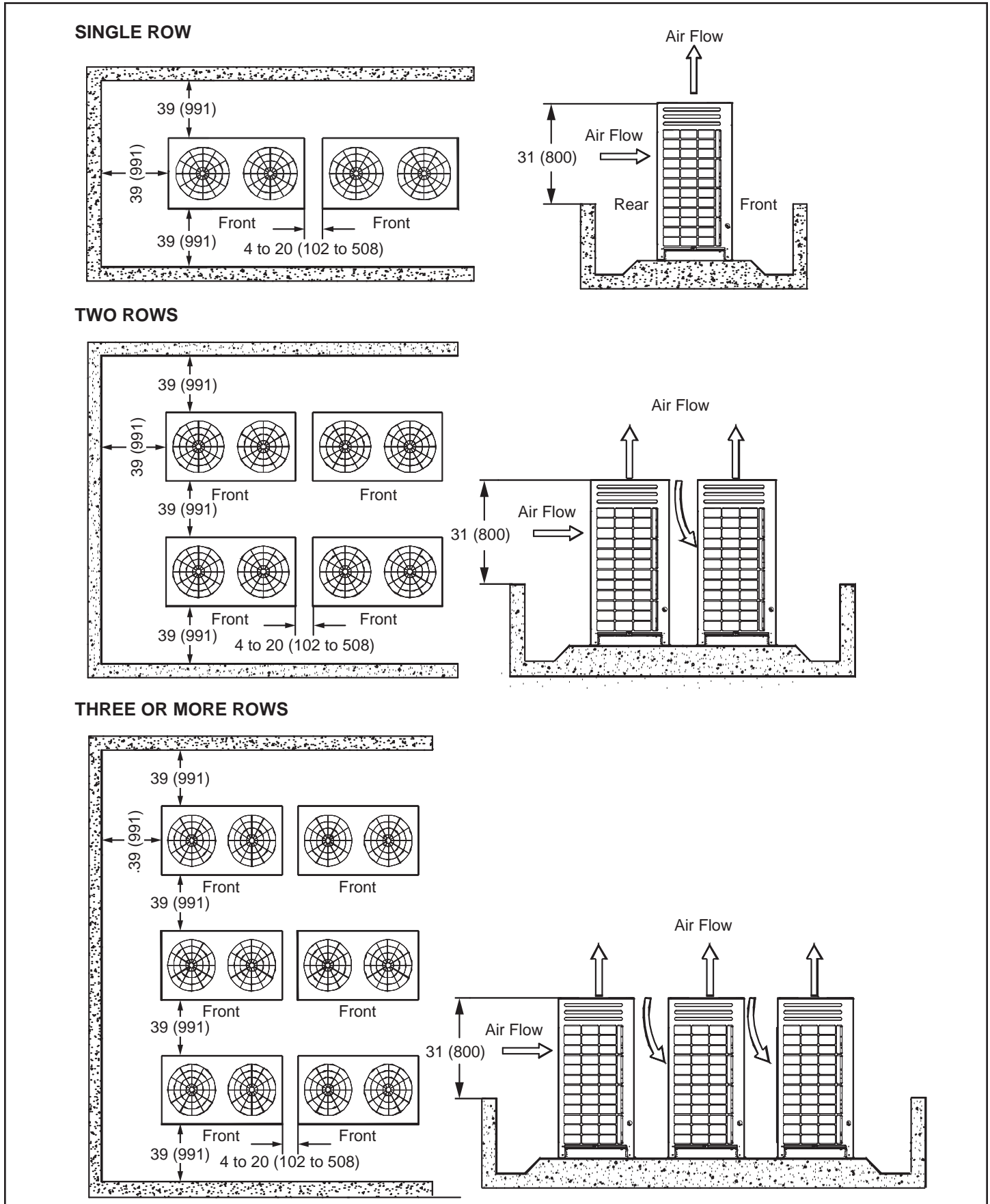

Figure 1. Installation Clearances - inches (mm)

⚠ NOTICE

Drawings in this manual are for illustrative purposes and should not be used as a template for fabricating field-supplied accessories or apparatuses. Consider the environment in which this unit is being installed and make necessary adjustments to ensure safe operation. Local codes prevail.

Vertical Clearances

- Obstructions must be 32 in. (813 mm) below the top of the outdoor unit or a field supplied air discharge duct is required.
- If the outdoor unit is LOWER than surrounding obstacles, add a field-supplied duct onto the outdoor unit's exhaust hood to facilitate heat dissipation.

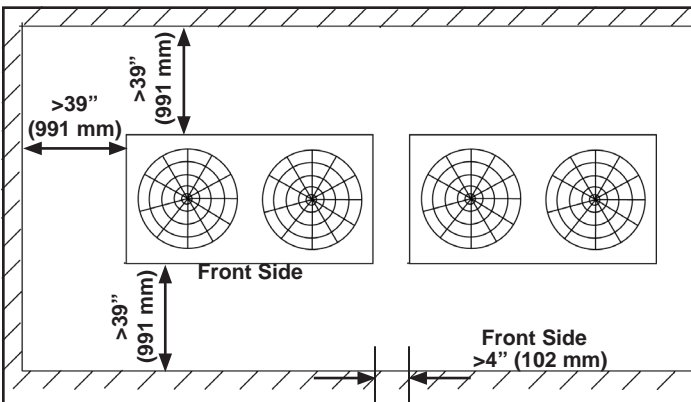

Figure 2. Horizontal Obstructions

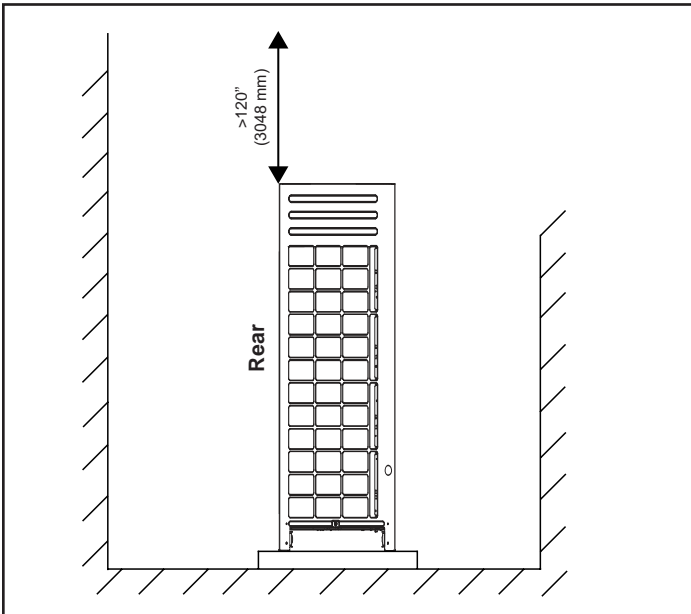

Figure 3. Vertical Obstructions

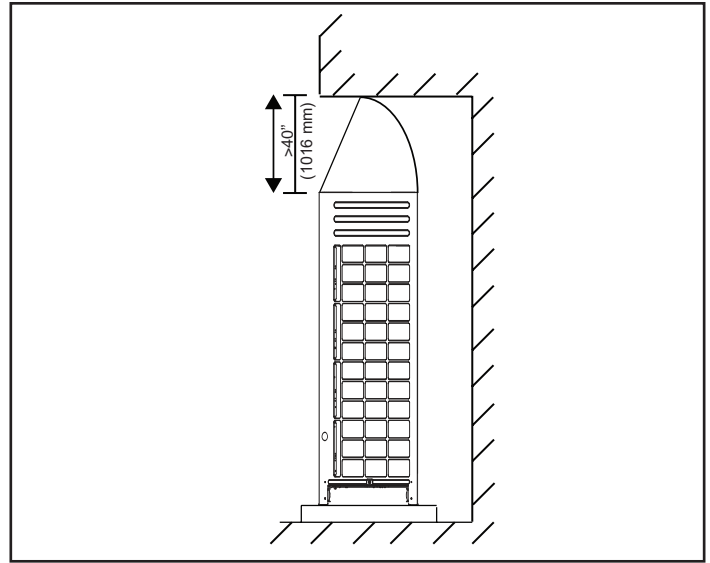
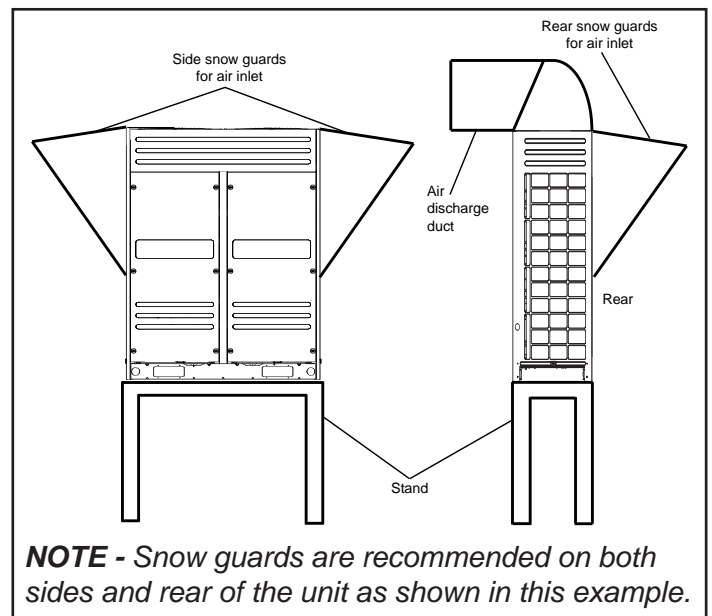

Figure 4. Ducted Air Discharge Around Obstructions

Cold Climate Considerations

- The unit base should be elevated above the depth of average snows. In heavy snow areas, do not locate the unit where drifting will occur.
- When installed in areas where low ambient temperatures exist, locate unit so winter prevailing winds do not blow directly on to the outdoor unit.
- Locate unit away from overhanging roof lines which would allow water or ice to drop on, or in front of, coil or into unit.
- Install snow guards to prevent snow fall from entering air inlet and outlet. See figure 5.



NOTE - Snow guards are recommended on both sides and rear of the unit as shown in this example.

Figure 5. Snow Protection Example

Air Discharge Duct

- Before installing the air duct, remove the two fan guards from the top of the unit.
- Duct each outdoor unit separately. Do not use a combined plenum as this may result in air being not discharged directly to the outside.
- Only one bend is allowed in the air duct.

- Duct louvers will reduce air volume, cooling and heating capacity and efficiency. Louvers are not recommended; but, if they are required by the job, the louver angle should be no larger than 15°.
- It may be necessary to install a flexible connector between the unit and the duct to reduce vibration noise.

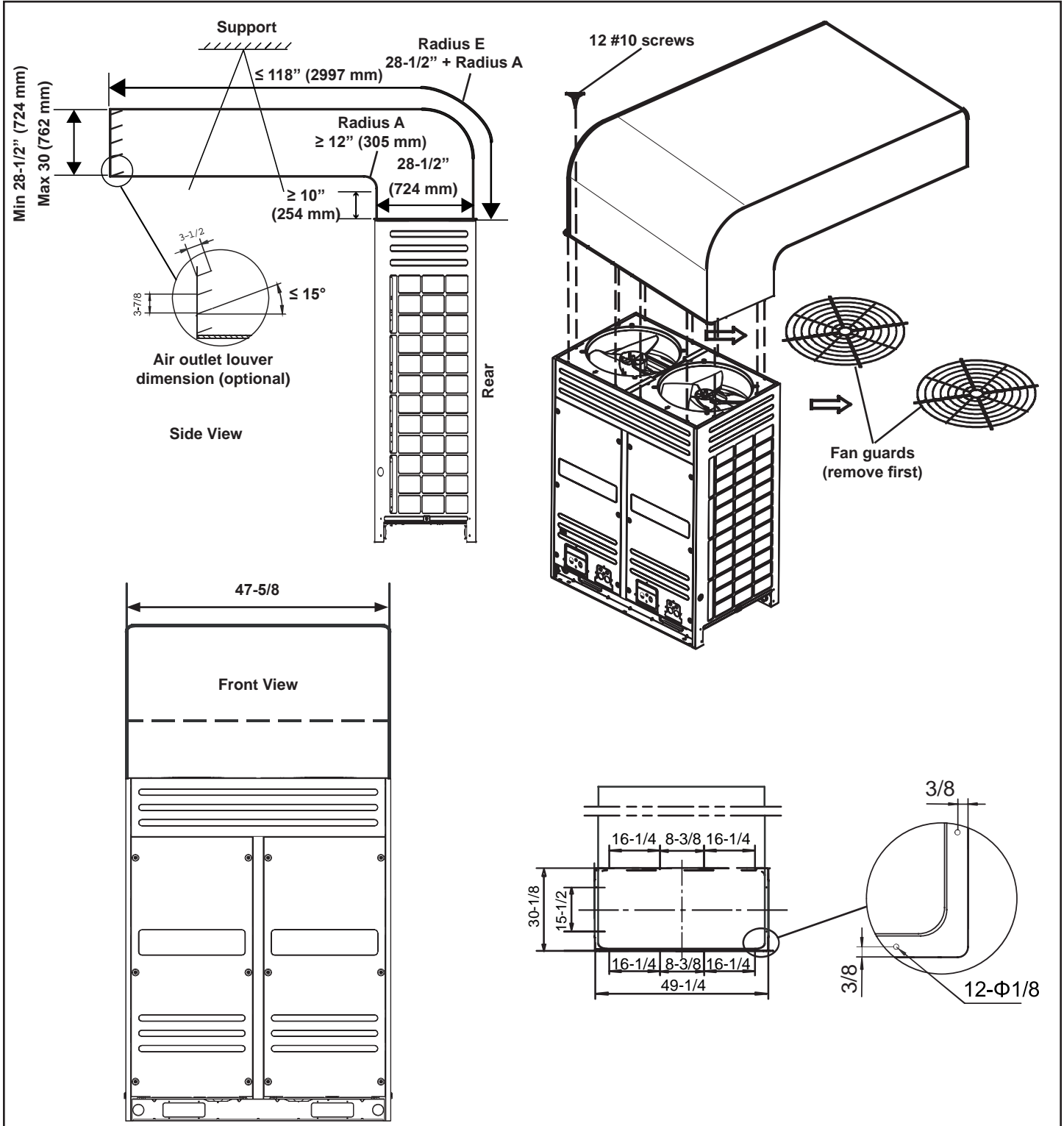
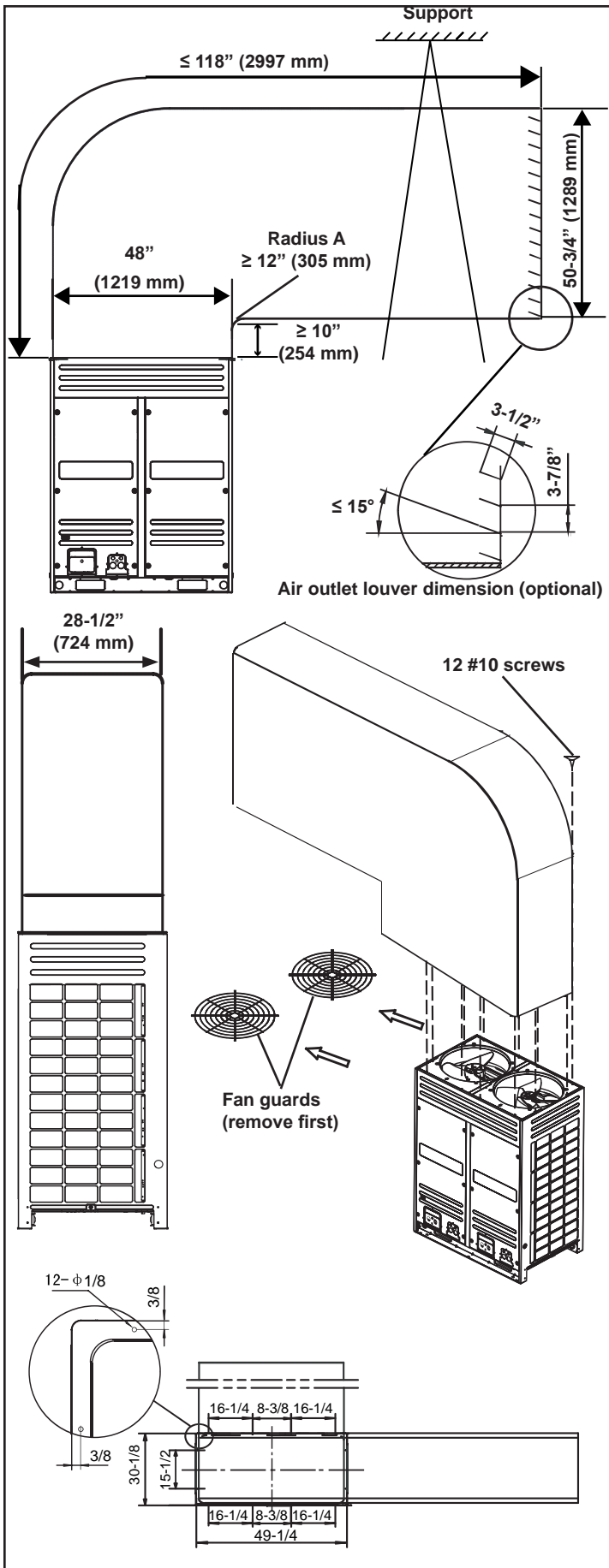
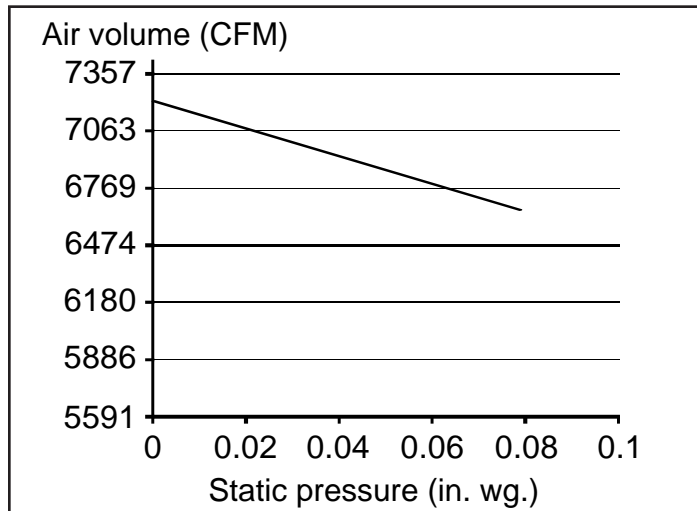

Figure 6. Air Discharge Duct (Front or Rear Connection)



Discharge Duct Pressure Curves



VRA072, 096, and 120

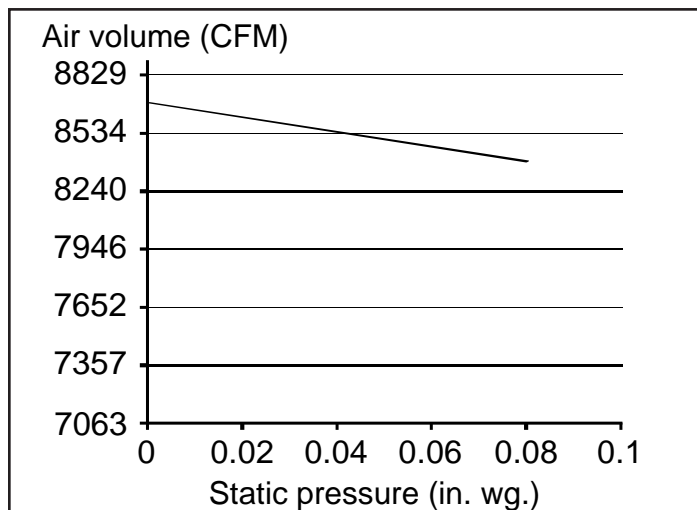

VRA144

Figure 7. Air Discharge Duct (Side Connection)

▲ CAUTION

In order to avoid injury, take proper precaution when lifting heavy objects. Take care when using a sling to lift the unit for installation. The unit center of gravity is not at its physical center.

Main/Sub Outdoor Unit Placement

- A VRF system consisting of more than two outdoor units, must be placed in order from the largest to the smallest capacity. See figure 8.
- The largest capacity outdoor unit must be installed closest to the main pipe leading into the building. See figure 8.
- The largest capacity outdoor unit address is the main unit, while the others are the sub units. See figure 8.
- All the outdoor units manifolded together should be installed at the same elevation.

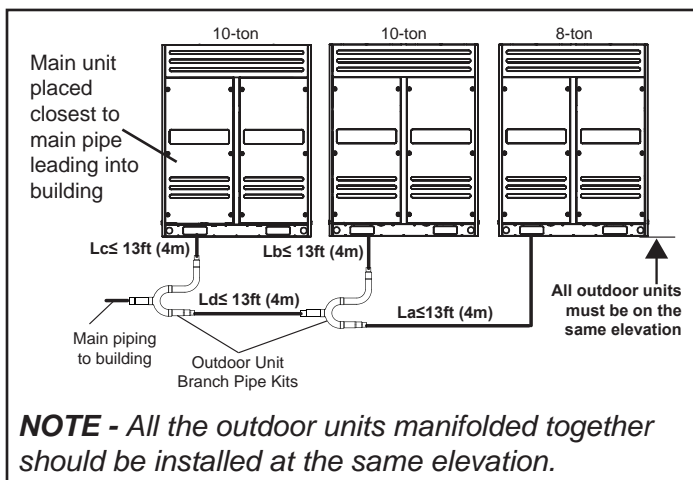

Figure 8. Main/Sub Unit Placement (28-Ton System Example)

Installation

Slab or Roof Mounting

Install the unit a minimum of 8 inches (203 mm) above the roof or ground surface to avoid ice build-up around the unit. Locate the unit above a load-bearing wall or area of the roof that can adequately support the unit. Consult local codes for rooftop applications.

- Use a field supplied slab or suitably sized steelwork to construct a base for locating the condensing unit. All support work should be verified by a qualified engineer.
- If the unit coil cannot be installed away from prevailing winter winds, a wind barrier should be constructed. Size barrier at least the same height and width as outdoor unit. Install barrier 12 inches (305 mm) minimum from the sides of the unit in the direction of prevailing winds.

IMPORTANT!

Roof Damage!

This system contains both refrigerant and oil. Some rubber roofing material may absorb oil. This will cause the rubber to swell when it comes into contact with oil. The rubber will then bubble and could cause leaks. Protect the roof surface to avoid exposure to refrigerant and oil during service and installation. Failure to follow this notice could result in damage to roof surface.

Securing Outdoor Unit to Slab or Frame

Use lag bolts at all four corners to secure the unit to the field-provided slab or frame. Isolation material can be used to control vibration or sound transmission, lag bolt must extend through material to the slab or frame. See figure 9.

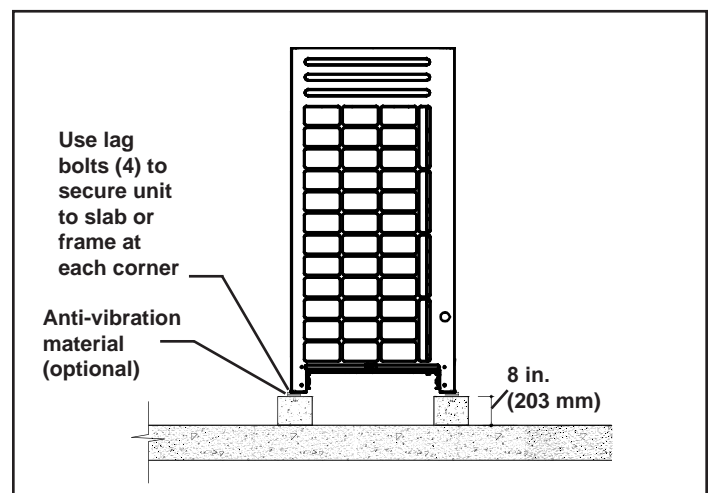

Figure 9. Securing Outdoor Unit to Slab or Frame

Refrigerant Piping Connections

⚠WARNING

Refrigerant leaks are unlikely; however, if a refrigerant leak occurs, open a door or windows to dilute the refrigerant in the room. Turn off the unit and all other appliances that may cause a spark. Call a licensed professional HVAC technician (or equivalent) to repair the leak. Use only R-410A refrigerant to charge this system. Use of other refrigerant or gas will damage the equipment.

Do not allow air or other contaminants to enter system during installation of refrigerant piping. Contaminants will result in lower system capacity and abnormally high operating pressures and may result in system failure or explosion.

Insulate all refrigerant piping.

Refrigerant pipes may be very hot during unit operation. Do not allow contact between wiring and bare copper pipes.

After refrigerant piping connections have been completed, check the system for leaks per commissioning instructions.

- Both liquid and gas (vapor) lines must be individually insulated.
- Field piping consists of three field-provided copper refrigerant lines connected to the outdoor unit. These lines carry the liquid and vapor refrigerant to and from the mode selection box(es).
- Refrigerant piping and wiring connections can be brought into the outdoor unit through openings provided in the front, side(s), pipe and underside (recommended) of the unit.
- Refrigerant piping must be connected using mode selection boxes and individual branch pipe kits. Four mode selection boxes are available in varying sizes to accommodate connection of one to 24 indoor units.
- The following restrictions apply to each VRA system:
 - Total refrigerant pipe length 3280 ft. (1000 m)
 - Longest pipe length actual) 574 ft. (175 m)
 - Level difference between indoor units 98 ft. (30 m)
 - Piping length from the first branch pipe to the farthest indoor unit 132/295 ft. (40/90 m)
- For each branch pipe, allow 19-1/4" (488 mm) of equivalent length.
- When the outdoor unit is installed 66 feet (20 m) or more above the indoor units, install an oil return trap every 33 feet (10 m) in the main gas pipe. See figure 10 for trap specifications.

- When the outdoor unit is 132 feet (40 m) or more below the indoor units, increase the diameter of the liquid line pipe from the outdoor unit to the first branch pipe by one size.

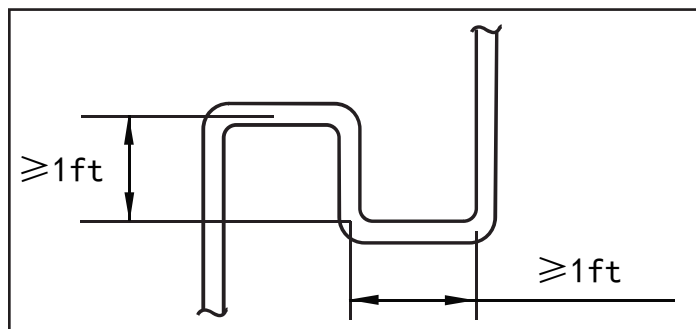

Figure 10. Oil Return Trap

- To extend the length from the first branch pipe to the farthest indoor unit beyond 132 ft. (40 m) and up to 295 ft. (90 m), the following three conditions must be met.
 1. Increase diameter of the main pipe between the first and the last branch pipes. If the diameter of the pipe is the same as the main outdoor pipe, then it does not need to be increased. Ex: If $132 \text{ ft.} < L1+L7+L9+L10 \leq 295 \text{ ft.}$, increase the diameter of all the pipes by one size.
 2. The length from the indoor unit to the nearest branch pipe must be 132 ft. (40 m) or less. Ex: $a,b,c,d,e,f,g,h,i,j,k,l,m \leq 132 \text{ ft.}$
 3. The difference between [the distance from the outdoor unit to the farthest indoor unit] and [the distance from the outdoor unit to the nearest indoor unit] is $\leq 132 \text{ ft.}$ Ex: $(L1+L7+L9+L11+11+j+k+n) - (L1+L7+L8+p) \leq 132 \text{ ft.}$

IMPORTANT!

The compressor in this unit contains PVE oil (Polyvinylether). PVE oil is formulated for hydrofluorocarbon (HFC) refrigerants, such as R-410a, which this system contains. While it may have some miscibility properties with mineral based oil and POE oil (Polyolester), you should not mix PVE oil with any other type of refrigerant oil.

Maximum Permitted Refrigerant Pipe Length and Maximum Height Difference

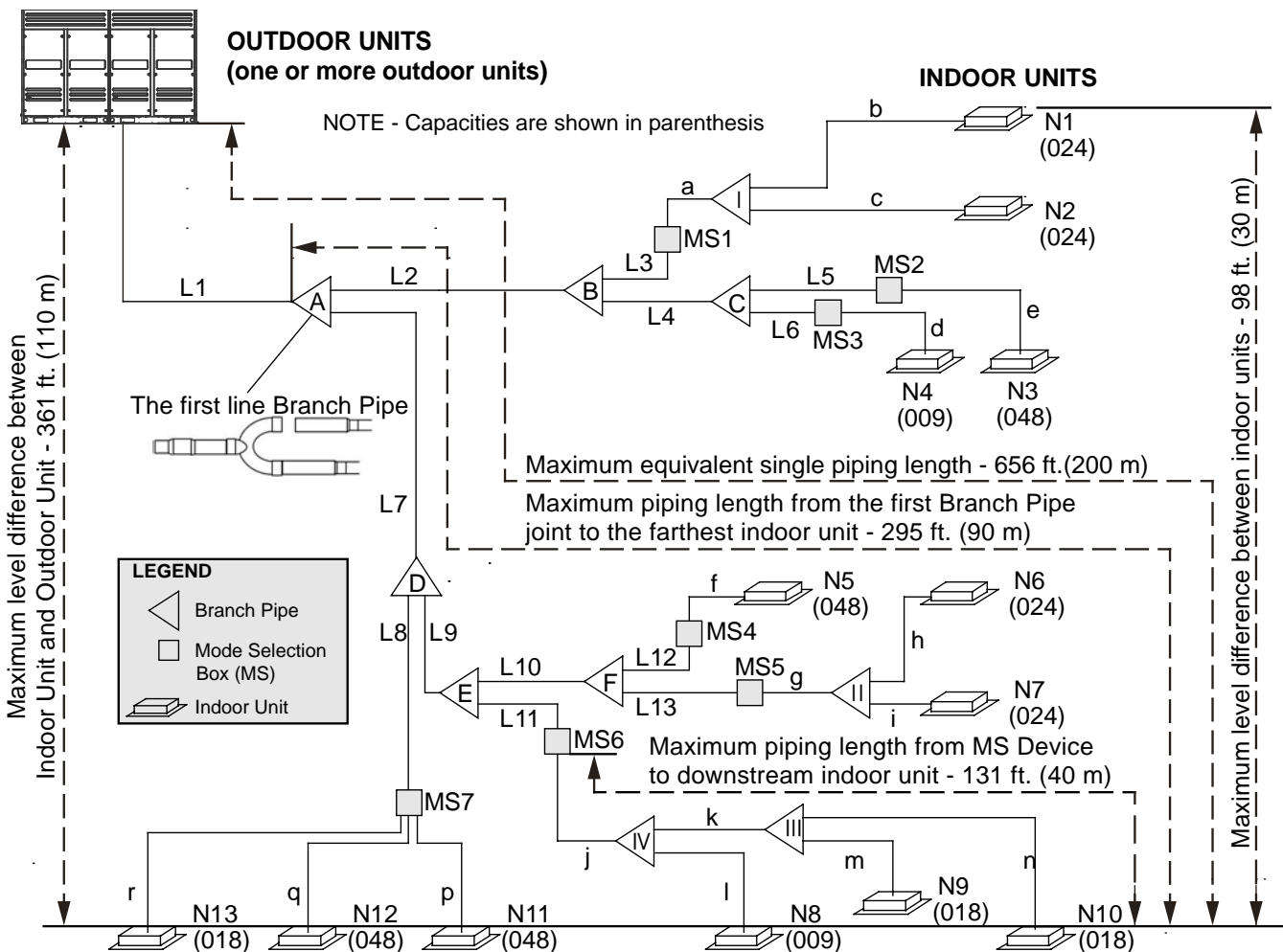

Piping Length		Permitted value	Piping	
Piping Length	Total piping length	1 3280 ft. (1000 m)	$L1+(L2+L3+L4+L5+L6+L7+L8+L9+L10+L11+L12+L13) \times 2+a+b+c+d+e+f+g+h+i+j+k+l+m+n+p+q+r$	
	Single piping length	Actual length	574 ft. (175 m)	
		Equivalent length	2 656 ft. (200 m)	
	Piping length from the first branch joint to the farthest indoor unit	3 132/295 ft. (40/90 m)	$L7+L9+L11+j+k+n$	
Piping length from Mode Selection Box (MS) to the downstream indoor unit of itself	132 ft. (40 m)	$j+k+n$		
Level Difference	Level difference between indoor unit and outdoor unit	Outdoor unit up	4 230 ft. (70 m)	---
		Outdoor unit down	5 360 ft. (110 m)	---
	Level difference between indoor units	98 ft. (30 m)	---	

NOTES:

The first branch in all systems must be centrally located between all Mode Selection (MS) Boxes.

¹ When counting the total piping length, double the actual length of the distribution pipes between first Branch Pipe joint and Mode Selection Box (MS): Installation.
 Total piping length = $L1+(L2+L3+L4+L5+L6+L7+L8+L9+L10+L11+L12+L13) \times 2+a+b+c+d+e+f+g+h+i+j+k+l+m+n+p+q+r \leq 3280 \text{ ft. (1000 m)}$.

² Each Branch Pipe is equivalent to 20 in. (508 mm).

³ The maximum allowable piping length from the first Branch Pipe joint to the farthest indoor unit must be $\leq 132 \text{ ft. (40 m)}$, but if the following conditions are met, the maximum allowable length can be extended to 295 ft. (90 m):

- The piping length from each indoor unit to the nearest Branch Pipe joint or direct connected Mode Selection Box (MS) must be less than 132 ft. (40m) (b to r).
- The difference in length between the outdoor unit to the farthest indoor unit, and the outdoor unit to the nearest indoor unit is $\leq 132 \text{ ft. (40 m)}$.
 Example: The farthest indoor unit is N10, The nearest indoor unit is N11 ($L1+L7+L9+L11+j+k+n$) minus ($L1+L7+L8+p$) $\leq 132 \text{ ft. (40 m)}$.
- Increase the distribution pipe diameter between the first Branch Pipe and Mode Selection Box (MS) L2-L13. If the pipe diameter is the same as the main outdoor pipe, it does not need to be increased.

Pipe Size Allowable Increase Diameters (in.):

3/8 to 1/2	1/2 to 5/8	5/8 to 3/4	3/4 to 7/8	7/8 to 1-1/8	1-1/8 to 1-3/8	1-3/8 to 1-5/8	1-5/8 to 2-1/8
------------	------------	------------	------------	--------------	----------------	----------------	----------------

⁴ When the outdoor unit is higher than indoor units and the level difference is over 65.6 ft. (20 m), it is recommended to set an oil return bend every 32.8 ft.(10 m) in the gas pipe of the main pipe. Refer to Installation Instructions for additional details.

⁵ When the outdoor unit is lower than indoor units and the level difference is more than 132 ft.(40 m), the main liquid pipe pipe need to increase by one size.

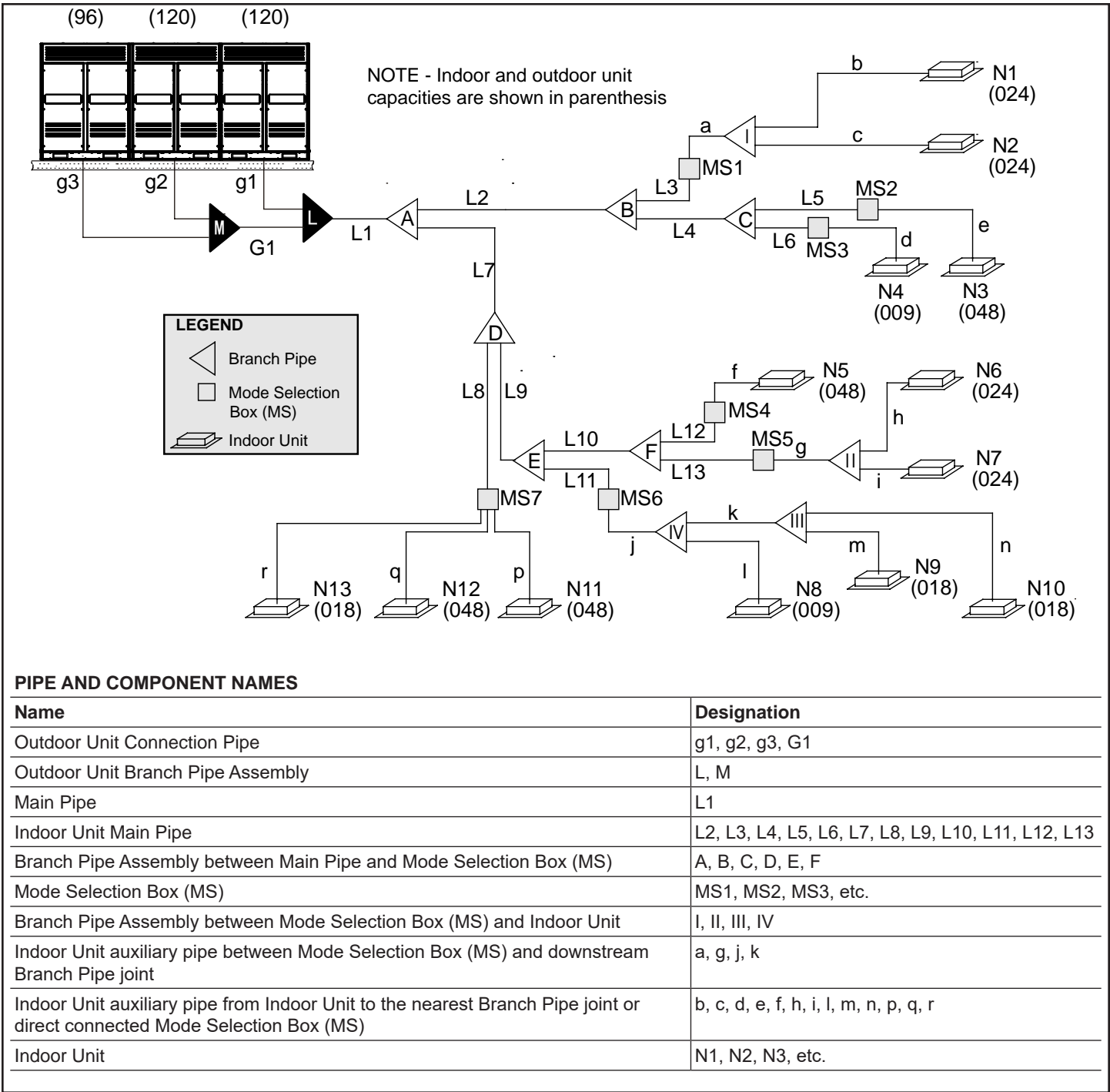

Figure 11. Typical Refrigerant Piping Diagram

OUTDOOR UNIT MAIN PIPE SELECTION (L1)

Outdoor Unit Size	Main Pipe Diameter (in.)							
	Equivalent length of all liquid pipes is <u>less</u> than 295 ft. (90 m)			First Branch Pipe Assembly	Equivalent length of all liquid pipes is <u>more</u> than 295 ft. (90 m)			First Branch Pipe Assembly
	Low Pressure Gas Pipe	High Pressure Gas Pipe	Liquid Pipe		Low Pressure Gas Pipe	High Pressure Gas Pipe	Liquid Pipe	
072	7/8	3/4	3/8	V8MSBP02	7/8	3/4	1/2	V8MSBP02
096	7/8	3/4	1/2	V8MSBP02	7/8	3/4	1/2	V8MSBP02
120	1-1/8	3/4	1/2	V8MSBP03	1-1/8	3/4	5/8	V8MSBP03
144	1-1/8	7/8	5/8	V8MSBP03	1-1/8	7/8	5/8	V8MSBP03
168-216	1-3/8	1-1/8	5/8	V8MSBP04	1-3/8	1-1/8	3/4	V8MSBP04
240	1-3/8	1-1/8	5/8	V8MSBP04	1-3/8	1-1/8	3/4	V8MSBP04
264-312	1-3/8	1-1/8	3/4	V8MSBP04	1-3/8	1-1/8	7/8	V8MSBP04
336-432	1-5/8	1-3/8	3/4	V8MSBP05	1-5/8	1-3/8	7/8	V8MSBP05

Note - The Main Pipe (L1) can be selected from the Outdoor Unit Main Pipe Selection table or the Indoor Unit Main Pipe Selection table, the larger size must be used.

INDOOR UNIT MAIN PIPE SELECTION (L1 to L13)

Indoor Unit Total Capacity (kBtuh)	Indoor Unit Main Pipe Diameter (in.)			Branch Pipe Assembly
	Low Pressure Gas Pipe	High Pressure Gas Pipe	Liquid Pipe	
A < 018	1/2	3/8	1/4	V8MSBP01
018 ≤ A < 056	3/4	5/8	3/8	V8MSBP01
056 ≤ A < 078	7/8	3/4	3/8	V8MSBP02
078 ≤ A < 112	7/8	3/4	1/2	V8MSBP02
112 ≤ A < 156	1-1/8	7/8	1/2	V8MSBP03
156 ≤ A < 224	1-1/8	7/8	5/8	V8MSBP03
224 ≤ A < 314	1-3/8	1-1/8	3/4	V8MSBP04
314 ≤ A < 460	1-5/8	1-3/8	3/4	V8MSBP05
≤ 460	1-5/8	1-3/8	7/8	V8MSBP05

OUTDOOR UNIT PIPE SELECTION (g1, g2, g3, G1)

Pipe	Outdoor Unit Size	Pipe Diameter (in.)		
		Low Pressure Gas Pipe	High Pressure Gas Pipe	Liquid Pipe
g1, g2, g3	6 or 8 ton	7/8	3/4	1/2
	10 or 12 ton	1-1/8	3/4	5/8
G1	- - -	1-3/8	1-1/8	3/4

OUTDOOR UNIT BRANCH PIPE ASSEMBLY SELECTION (L, M)

Outdoor Unit Quantity	Parallel Connection with Branch Pipes
2 units	L use V8ODBP02HR
3 units	L + M use V8ODBP03HR

INDOOR UNIT AUXILIARY PIPE SELECTION (Between Branch Box (MS) And Downstream Branch Joint) (a, g, j, k)

Indoor Unit Capacity (kBtuh)	Pipe Diameter (in.)		Available Branch Pipe
	Gas Pipe	Liquid Pipe	
A<56	5/8	3/8	V8IDBP01

INDOOR UNIT AUXILIARY PIPE SELECTION

(From Indoor Unit To The Nearest Branch Joint Or Direct Connected Mode Selection Box (MS) (b, c, d, e, f, h, i, l, m, n, p, q, r)

Indoor Unit Capacity (kBtuh)	Pipe Diameter (in.)			
	Pipe length from indoor unit to nearest branch joint or direct connected Mode Selection Box (MS)			
	Pipe length <u>less</u> than 33 ft (10 m)		Pipe length <u>more</u> than 33 ft (10 m)	
	Gas Pipe	Liquid Pipe	Gas Pipe	Gas Pipe
A<18	1/2	1/4	5/8	3/8
18≤A<54	5/8	3/8	3/4	1/2

Name	Gas Side Joints (inch)	Liquid Side Joints (inch)	Insulation Material (furnished)
V8IDBP01			<p>(2 sets)</p>
V8IDBP02			<p>(2 sets)</p>
V8IDBP03			<p>(2 sets)</p>
V8IDBP04			<p>(2 sets)</p>
V8IDBP05			<p>(2 sets)</p>

Figure 12. Indoor Unit Branch Pipe Kits

	Low-Pressure Gas Side Joints - Inch	High-Pressure Gas Side Joints - Inch	Liquid Side Joints - Inch	Adapter Pipe - Inch	Insulation Material (furnished)
V8MSBP01				 (Low-pressure side used) / (High-pressure side used) / (Liquid side used)	
V8MSBP02				 (Liquid side used)	
V8MSBP03				 (Liquid side used)	
V8MSBP04				 (Liquid side used)	
V8MSBP05				 (Liquid side used)	

Figure 13. Mode Selection Box Branch Pipe Kits

- The seal on the unit refrigerant piping connections should remain in place until the last possible moment. This will prevent dust or water from getting into the refrigerant piping before it is connected.
- Flow the pipework with dry (oxygen-free) nitrogen (2.9 psig or 3 CFH) during brazing to avoid oxidation which may block the refrigerant piping.
- Do not use anti-oxidants when brazing.
- Do not use flux when brazing copper-to-copper piping. Use phosphor copper brazing filler alloy (BCuP) which does not require flux. Flux has a harmful effect on refrigerant pipe.
- Use a wet cloth to insulate the shut off valve during brazing.
- Use dedicated gauges and hoses with R-410A equipment.

Pressure Test

- Follow the pressure test specifications in table 1 for pressure test.
- Use oxygen-free nitrogen to pressure test to 650 psig and hold for 1 hour.

Evacuate System

- Follow the Lennox pressure test specifications in table 1 and the triple evacuation process described on this page to pressure test and evacuate the system.
- Use a vacuum pump capable of evacuating to lower than 500 Microns (0.5 Torr).
- Do not open any of the outdoor unit shut-off valves (possible max 5 valves). The outdoor unit does not need to be evacuated.
- Evacuate the system to 500 Microns (0.5 Torr), or below, for 4 hours.

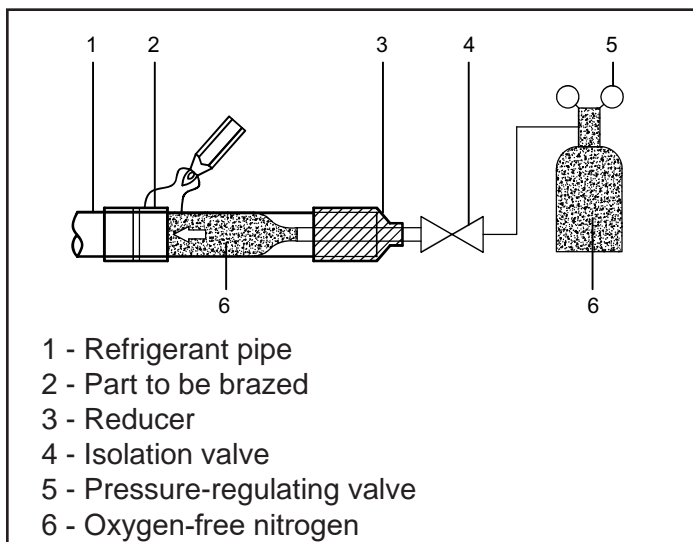

Figure 14. Brazing Best Practices

IMPORTANT!

Use only oxygen-free nitrogen (OFN).

Table 1. Pressure Test Specifications

1	3 bar	44 psig	minimum of 10 minutes
2	15 bar	220 psig	minimum of 10 minutes
3	32 bar	470 psig	minimum of 10 minutes
4	45 bar	650 psig	1 hour. Stress test to prove the integrity of the complete installation.
5	32 bar	470 psig	24 hours. Lower system pressure test, after confirmation No. 4 was successfully completed.

Triple Evacuation Procedure

A Micron or Torr gauge must be used for this procedure.

1. Discharge the oxygen-free nitrogen and evacuate the system to a reading of 8000 Microns (8 Torr) using all service valves.
2. Break the vacuum by allowing nitrogen into the three inter-connecting pipework port connections (low pressure gas pipe, high pressure gas pipe and liquid line pipe) until a positive pressure is achieved.
3. Evacuate the system to a reading of 5000 Microns (5 Torr).
4. Break the vacuum by allowing nitrogen into the three inter-connecting pipework port connections (low pressure gas pipe, high pressure gas pipe and liquid line pipe) until a positive pressure is achieved
5. Evacuate the system to a minimum reading of 500 Microns (0.5 Torr).
6. For a moisture free system, ensure the vacuum is held without movement for a minimum of 4 hours.
7. If pressure loss is detected, carry out steps 2 through 6 until no pressure loss is observed.

Additional Refrigerant Charge

1. Calculate the additional refrigerant charge using the diameter and length of the liquid pipe (only) using Table 2 below.
2. Calculate the additional refrigerant charge for each liquid line branch pipe kit.
3. Calculate the additional refrigerant charge for each Mode Selection Box using Table 3 below.
4. If the ratio of VMDB or V33B Indoor unit capacity exceeds 80% of all indoor units, use Table 4 to determine the additional refrigerant charge to add.
5. Total all calculations.
6. Add the calculated additional refrigerant to the system.

Liquid Line Length Calculation

Calculate additional refrigerant charge using the diameter and length of the liquid pipe.

Table 2. Liquid Line Calculation

$$\begin{aligned}
 \text{Liquid Line Additional Refrigerant (lbs.)} = & \left(\begin{aligned} & \left(\begin{array}{l} \text{Total length (ft) of} \\ \text{liquid piping size} \\ \text{at } \Phi 7/8 \end{array} \right) \times 0.255 + \left(\begin{array}{l} \text{Total length (ft) of} \\ \text{liquid piping size} \\ \text{at } \Phi 3/4 \end{array} \right) \times 0.181 \\ & + \left(\begin{array}{l} \text{Total length (ft) of} \\ \text{liquid piping size} \\ \text{at } \Phi 5/8 \end{array} \right) \times 0.120 + \left(\begin{array}{l} \text{Total length (ft) of} \\ \text{liquid piping size} \\ \text{at } \Phi 1/2 \end{array} \right) \times 0.080 \\ & + \left(\begin{array}{l} \text{Total length (ft) of} \\ \text{liquid piping size} \\ \text{at } \Phi 3/8 \end{array} \right) \times 0.040 + \left(\begin{array}{l} \text{Total length (ft) of} \\ \text{liquid piping size} \\ \text{at } \Phi 1/4 \end{array} \right) \times 0.015 \end{aligned} \right)
 \end{aligned}$$

Mode Selection Box Calculation

Use Table 3 to determine the amount of additional refrigerant for EACH mode selection box.

Table 3. Mode Selection Box Additional Charge

Mode Selection Box Model	Amount of refrigerant (lb/per)
V8MSBB01	0.66
V8MSBB02	0.66
V8MSBB03	1.10
V8MSBB04	1.10

Branch Pipe Kit Calculation

Add 1.60 ft. (488 mm) per EACH liquid line branch pipe (incoming pipe size only) for additional charge calculation.

Example: The branch pipe kit has an incoming pipe size of 7/8" and outgoing pipe sizes of 3/8" and 5/8". Use only the incoming pipe size of 7/8" to calculate the additional refrigerant charge for this branch pipe kit.

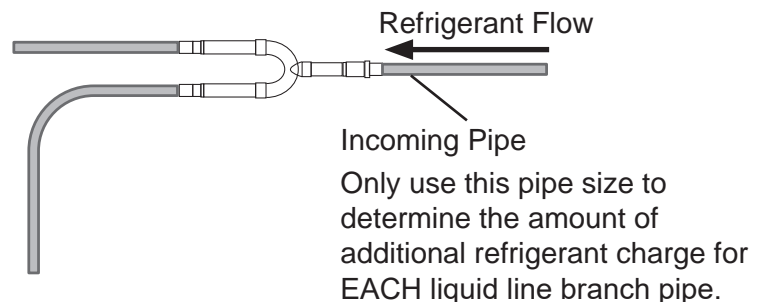

Table 4. VMDB or V33B Indoor Unit Capacity Ratio over 80% of All Indoor Units Additional Charge Amount

Outdoor Unit Module	Pounds of additional refrigerant if ratio of VMDB Indoor units exceeds 80% of all indoor units.	Pounds of additional refrigerant if ratio of V33B indoor units exceeds 80% of all indoor units.
VRA072H4M	6.61	8.59
VRA096H4M	6.61	12.12
VRA120H4M	8.81	13.22
VRA144H4M	11.02	13.22
VRA168H4M	12.12	19.84
VRA192H4M	13.22	21.16
VRA216H4M	13.22	21.16
VRA240H4M	13.88	21.16
VRA264H4M	14.10	21.16
VRA288H4M	14.77	21.16
VRA312H4M	15.21	21.16
VRA336H4M	15.43	21.16
VRA360H4M	15.87	21.16
VRA384H4M	17.19	21.16
VRA408H4M	19.40	21.16
VRA432H4M	20.28	21.16

Refrigerant Discharge

For systems containing more than 110 lb (50 kg) of R410A refrigerant, pressure-relief devices and fusible plugs shall discharge to the atmosphere at a location not less than 15 ft (4.57 m) above the adjoining

ground level and not less than 20 ft (6.1 m) from any window, ventilation opening, or exit in any building. Local codes may lower this charge limit and shall be investigated by the design engineer.

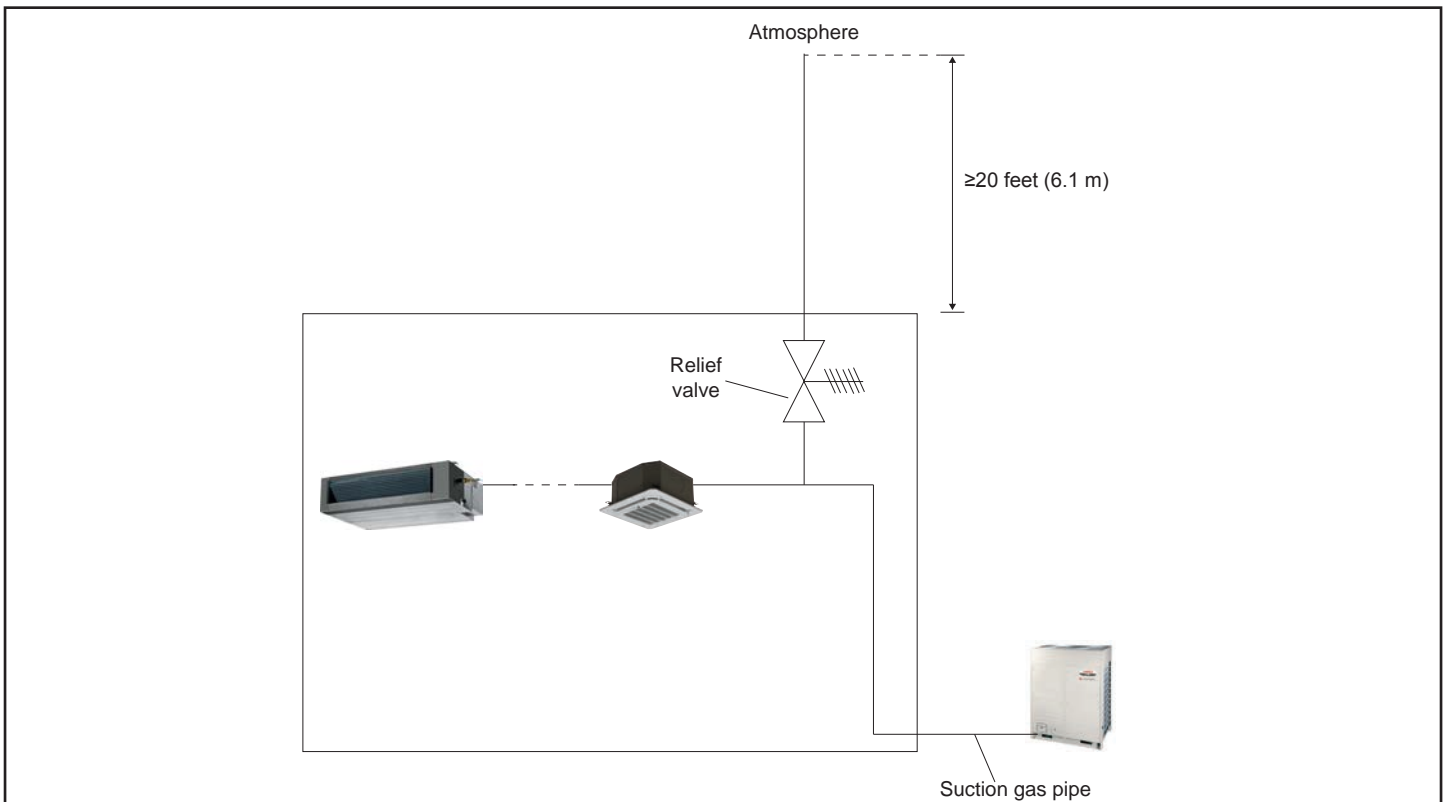

Figure 15. Refrigerant Discharge

Connecting Manifolded Units

- See the instruction manual included with the branch pipe kit for detailed connection information.
- Connect the branch pipes between outdoor units so that they are horizontal level $\pm 10^\circ$.
- Do not install outdoor unit branch pipes vertically.
- Do not allow pipe to block outdoor unit access panels.
- Install a reverse trap if needed.

NOTE - Outdoor unit is shipped for bottom pipe entry. For front pipe entry installation, use parts in accessory bag.

- Branch kits include pipes with graduated diameters. The piping can be cut to suit the installation needs.
- Use a pipe cutter designed for refrigeration tubing.
- Discard unused pipe.
- Refer to the Lennox VRF Selection Software (LVSS) pipe sizing diagram to obtain the correct inlet and outlet sizes for the installation.
- Keep all components sealed until brazing.

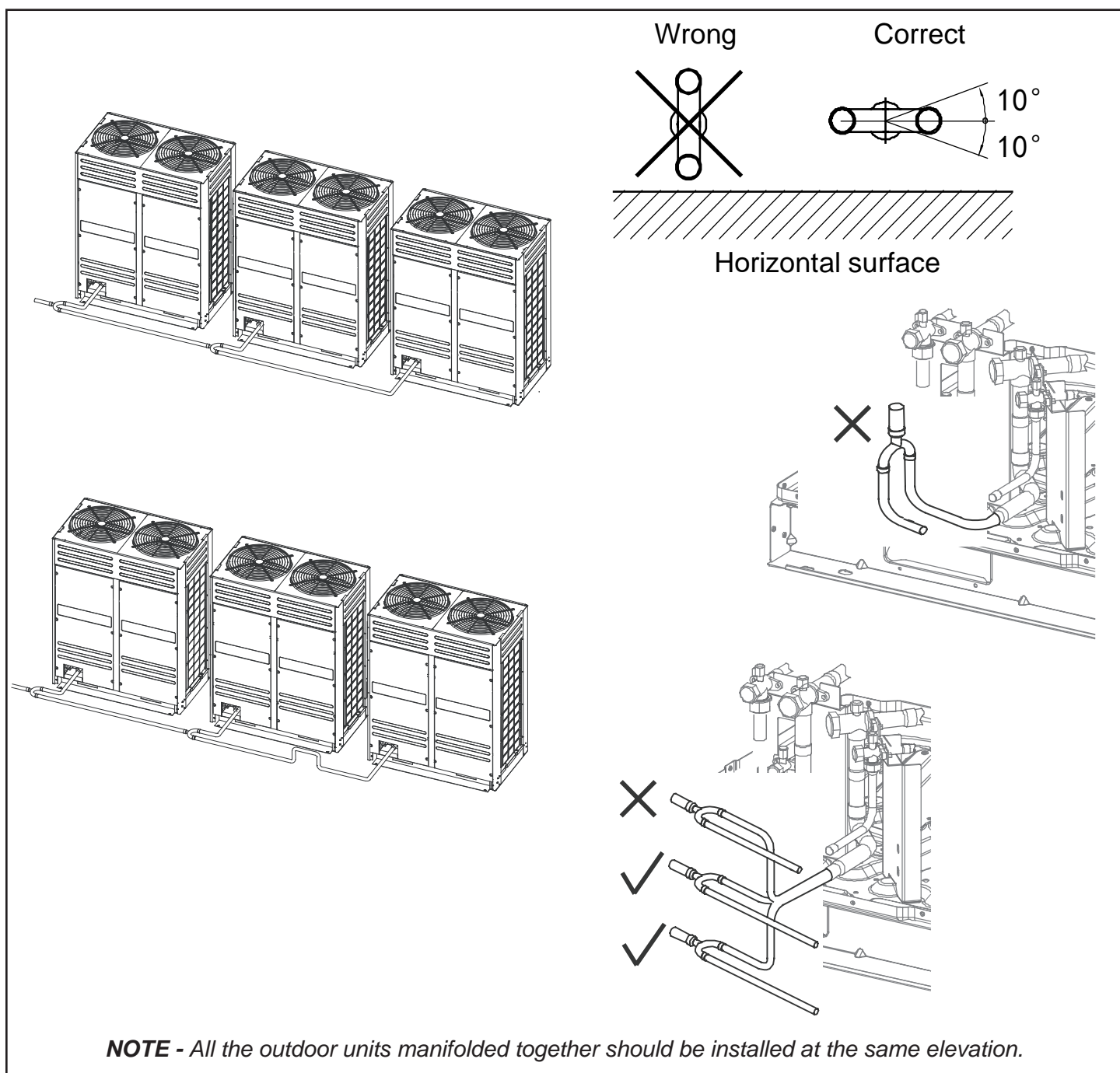

Figure 16. Connecting Manifolded Units

Internal valve layouts are the same in both heat recovery and heat pump units, it is their function that is different. Pay close attention when making final piping connections.

Heat Recovery internal valve layouts are described below. See the Heat Pump installation manual for heat pump internal valve information.

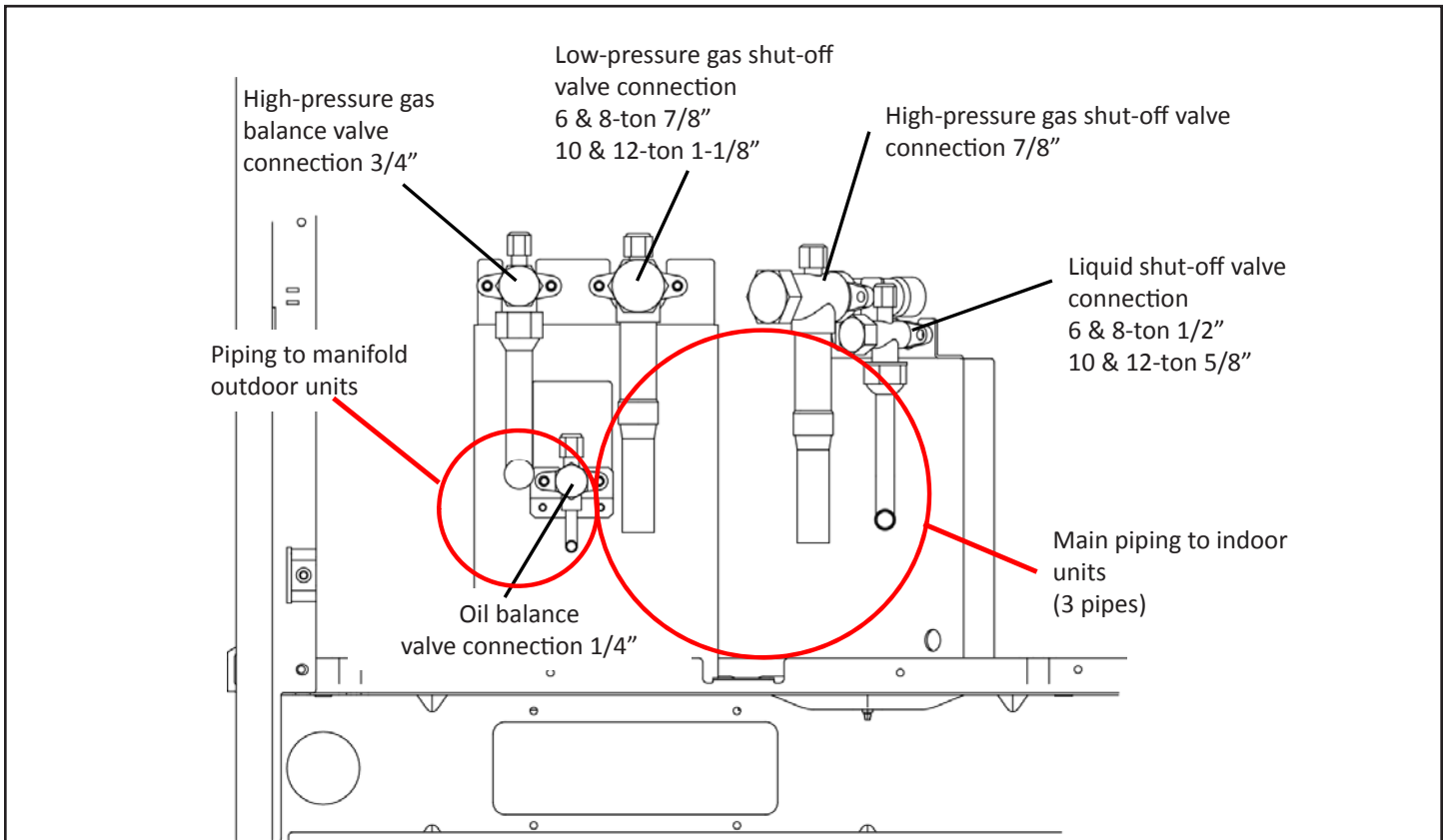

Figure 17. Heat Recovery Internal Valve Layout

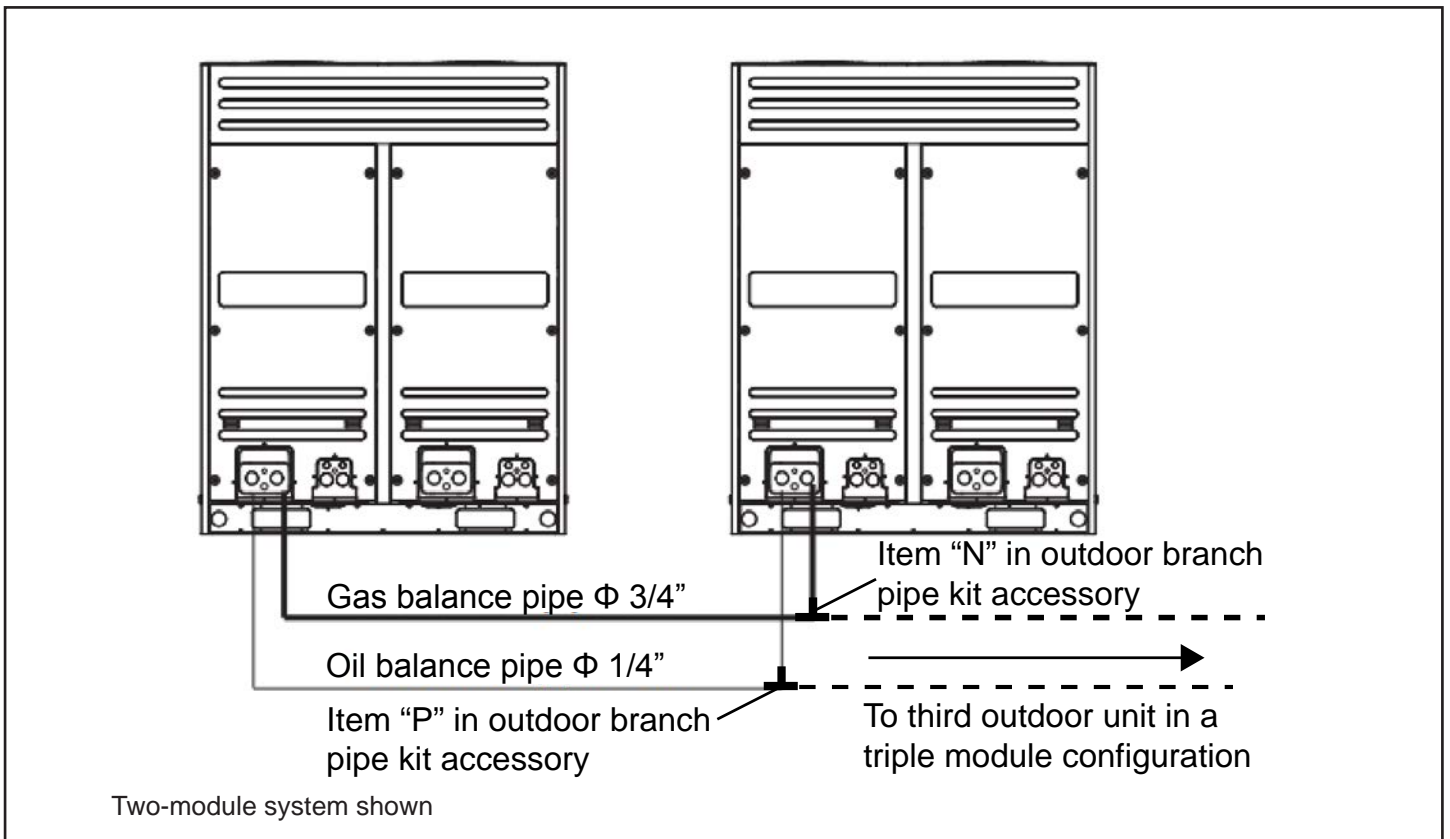
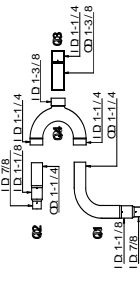
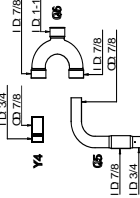
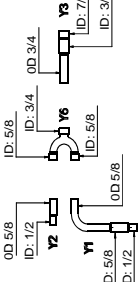
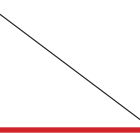
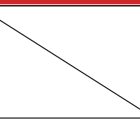
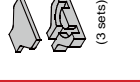
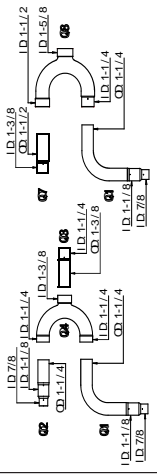
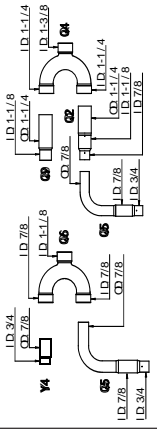
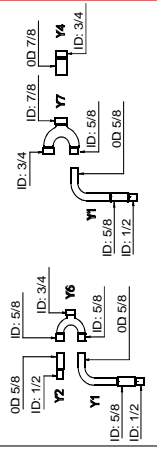
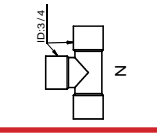
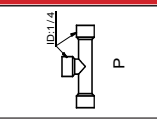



Figure 18. Connective Piping Sizes for Manifolder Outdoor Units

Name	Low-Pressure Gas Side Joints (inch)	High-Pressure Gas Side Joints (inch)	Liquid Side Joints (inch)	Gas Balance Joint (inch)	Oil Balance Joint (inch)	Insulation Material (furnished)
V80DBP02HR						
V80DBP03HR						

Triple-Module Balancing Pipes Only

Refer to the pipe sizing diagram in the LVSS report to determine pipe sizes. See figure 11 for or manual calculations.

Branch pipe kits are used to complete the piping for connecting outdoor units. T-shape connectors are used for balancing pipes only. U-shaped connectors are combined in the field to connect refrigerant piping for the structure. See figure 19.

Figure 19. Outdoor Unit Branch Pipe Kits

Connecting Mode Selection Boxes

- V8MSBB01 -- Maximum No. of Groups (1) x Indoor Units per Group (1) = 1
- V8MSBB02 -- Maximum No. of Groups (2) x Indoor Units per Group (4) = 8
- V8MSBB03 -- Maximum No. of Groups (4) x Indoor Units per Group (4) = 16
- V8MSBB04 -- Maximum No. of Groups (6) x Indoor Units per Group (4) = 24
- All indoor units on the same connection must operate in the same mode.
- Do not install in noise sensitive areas.
- The mode selection box must be installed level horizontal.
- Allow at least 3 ft. (1 m) distance between the mode selection box and the branch pipes.
- There will be a 30-second auto-check function performed after the indoor and outdoor units have been started.
- The indoor units require a unique address assigned by the remote controller. Mode selection boxes do not require addressing.
- See the instruction manual included with the mode selection box for detailed installation information.

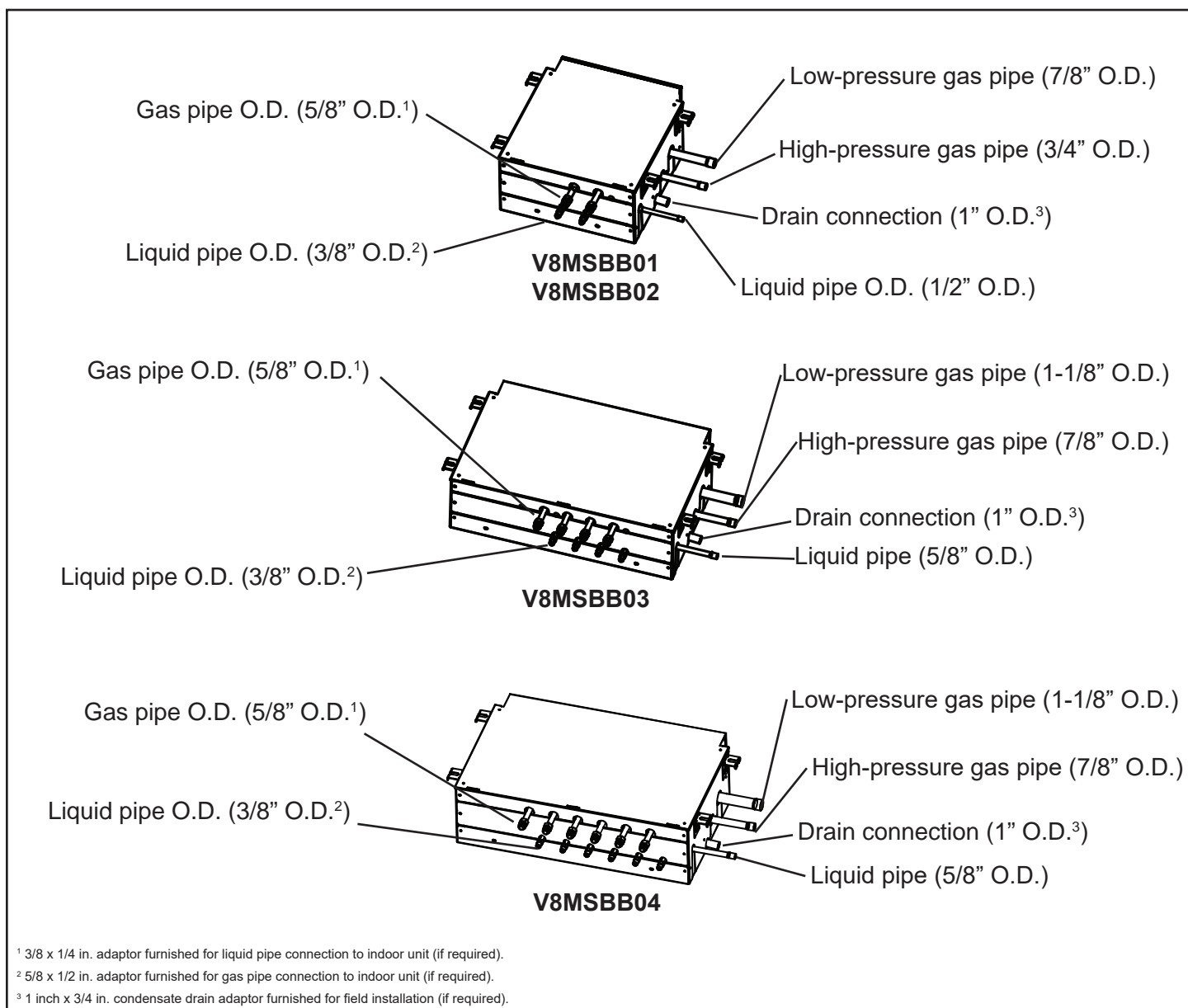
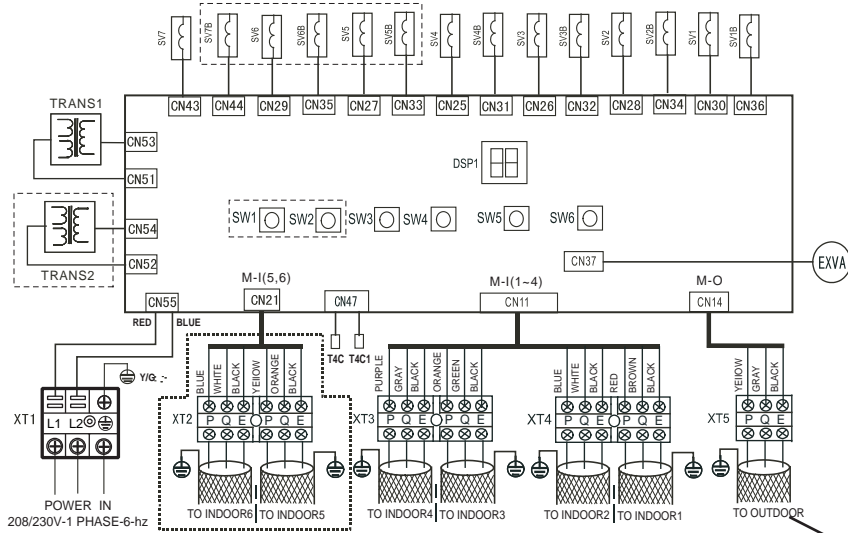
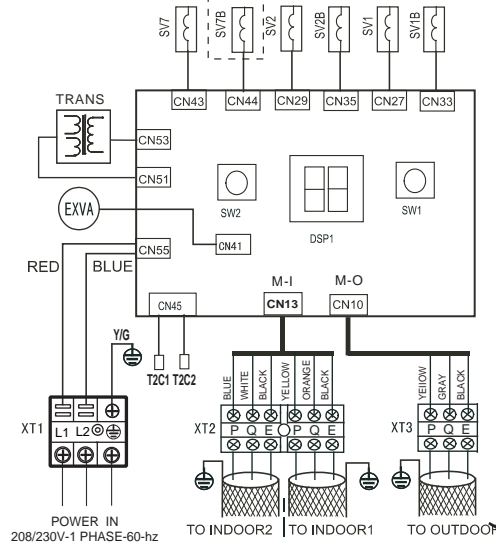

Figure 20. Mode Selection Box Piping Dimensions



V8MSBB03 or V8MSBB04

To other MS boxes on same refrigeration circuit.



V8MSBB02

To other MS boxes on same refrigeration circuit.

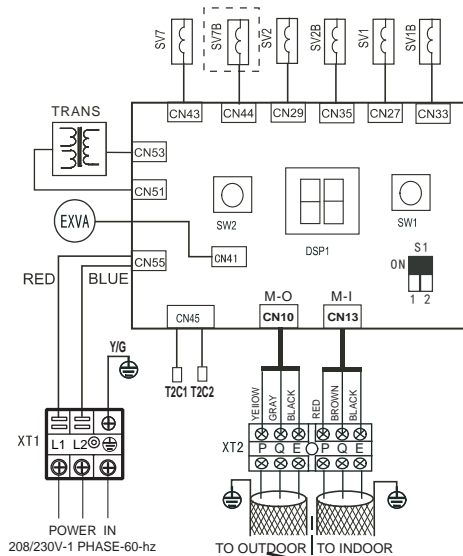

V8MSBB01

To other MS boxes on same refrigeration circuit.

Figure 21. Mode Selection Box Wiring Diagrams

Wiring Connections

⚠WARNING

Isolate the power supply before accessing unit electrical terminals.
 Install unit so that unit disconnect is accessible.
 Follow all local and national codes, as well as this installation instruction, during installation. Do NOT overload electrical circuit, as this may lead to failure and possible fire.
 Use specified wiring and cable to make electrical connections. Clamp cables securely and make sure that connections are tight to avoid strain on wiring. Insecure wiring connections may result in equipment failure and risk of fire.
 Wiring must be installed so that all cover plates can be securely closed.
 Do not attempt to repair a damaged power cord.
 Do not modify the power cord in any way. Do not attempt to extend the length of the power cord or use an extension cord with this appliance. Do not share the single power outlet with any other appliances.

⚠CAUTION

This unit must be properly grounded and protected by a circuit breaker. The ground wire for the unit must not be connected to a gas or water pipe, a lightning conductor or a telephone ground wire.
 Do not connect power wires to the outdoor unit until all other wiring and piping connections have been completed.
 Install all wiring at least 3 feet away from televisions, radios or other electronic devices in order to avoid the possibility of interference with the unit operation.
 Separate power wiring supplies must be provided for the outdoor unit and indoor unit(s).
 Do not cross-connect refrigerant piping or signal wires between VRF systems. Each VRF system must be piped and wired separately.
 Each indoor unit must have its own electrical disconnect.
 Do not run signal wire and power wire in the same conduit; keep distance between the two conduits per local codes. (Make sure to set address of outdoor unit in case of parallel multi-outdoor units.

NOTE - Each outdoor unit requires a separate power supply protected by a suitably sized circuit breaker.

1. Select the appropriate electrical inlet into the outdoor unit. Local and national codes apply.
2. Locate the terminal strip in the outdoor unit control box. Connect the power wiring (sized per NEC/CEC and local codes) and communications cable (3-conductor, shielded cable) per figure 22. Refer to unit nameplate for rated voltage.

IMPORTANT!

DO NOT adjust DIP switch settings. Settings may only be adjusted by a trained technician as part of the commissioning procedures.

Take care when making final power and control cable connections, cross connection will result in damage to unit's main board.

Only apply power to the system after performing all of the pre-commissioning steps.

Power Terminal Strip

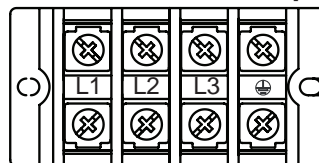

208/230V 60Hz 3Ph
 or 460V 60Hz 3Ph
 Power Supply

Communication Terminal Strip

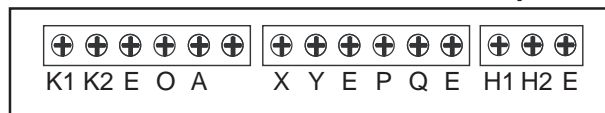

Outdoor Unit Information Circuit To LVM, BACnet, or LON system	To Kilowatt Hour Meter	Indoor Unit Information Circuit To LVM, BACnet, or LON system	System Communication Circuit To Indoor Units and Mode Selection Boxes	Between Outdoor Unit Modules
--	------------------------	---	---	------------------------------

NOTE - Use 18 GA 3-Conductor, Stranded, Shielded Communication Cable

Figure 22. Wiring Terminals

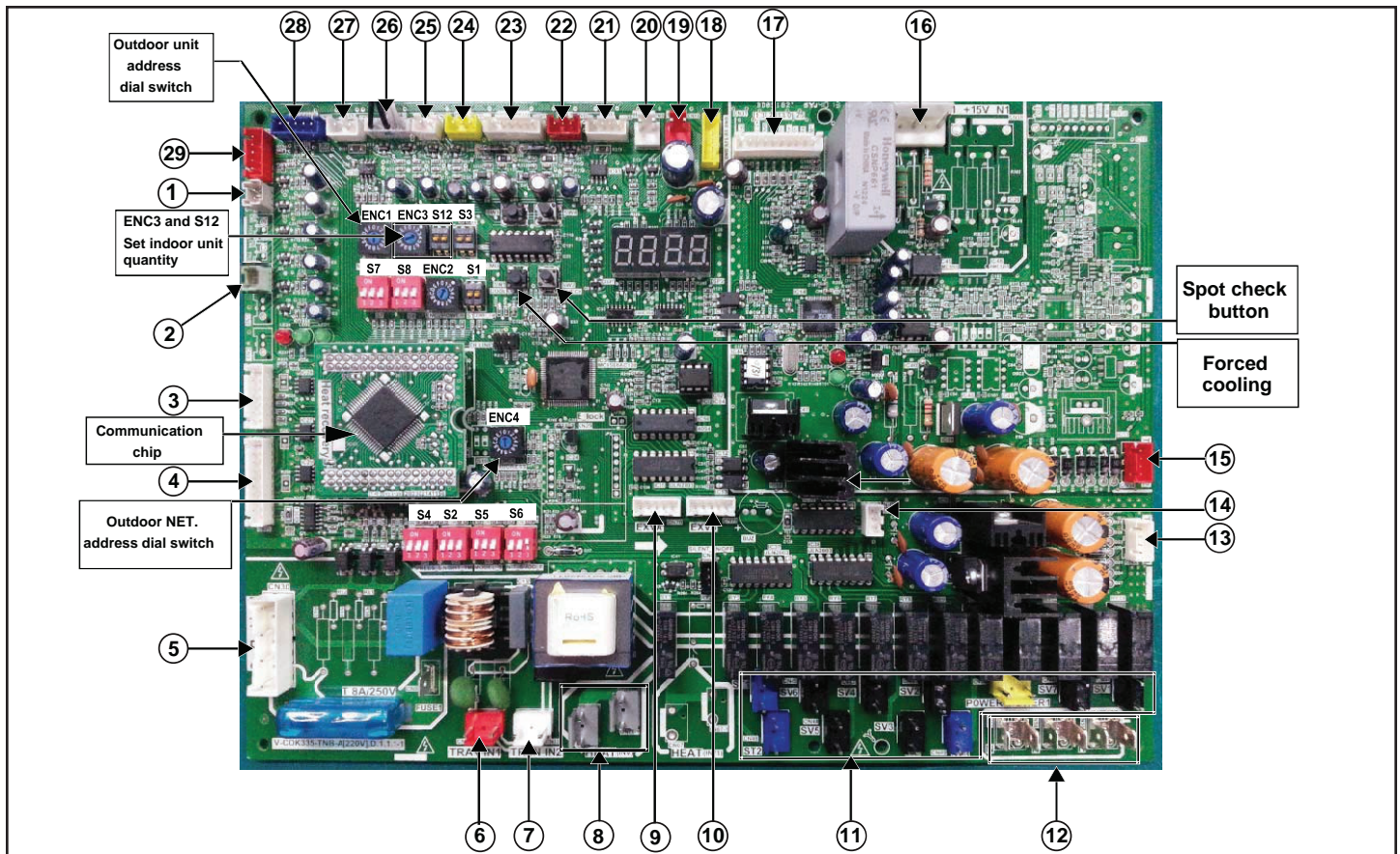

1	Discharge temp. sensor port of inverter compressor A
2	Heat sink temperature.
3	Reserve
4	Wiring port for communication between indoor and outdoor units, indoor unit network, outdoor unit network and network accounting
5	Power port
6	Power input of the No. 1 transformer
7	Power input of the No. 2 transformer
8	Crankcase heater power output port
9	EXV A driving port
10	EXV B driving port
11	Loading output terminal
12	L2 phase power
13	Power output of the No.1 transformer
14	5VDC, 12VDC power port
15	Power output of the No.2 transformer

16	Port for inverter module A voltage inspection
17	Control signal between main board and inverter module A
18	5VDC, 12VDC power input
19	Low pressure switch signal port
20	High pressure switch signal port
21	Reserve
22	Reserve
23	Current inspection port of the inverter compressors A
24	Input port for system high pressure inspection
25	Port for temperature sensor on left outdoor coils
26	Inspection port for temperature of outdoor ambient and right hand side outdoor coils sensors
27	Communication ports between outdoor units
28	Control port of DC fan B
29	Control port of DC fan A

**Figure 23. VRA072H4M-1, VRA096H4M-1, & VRA120H4M-1 Main Board
208/230V Board Shown**

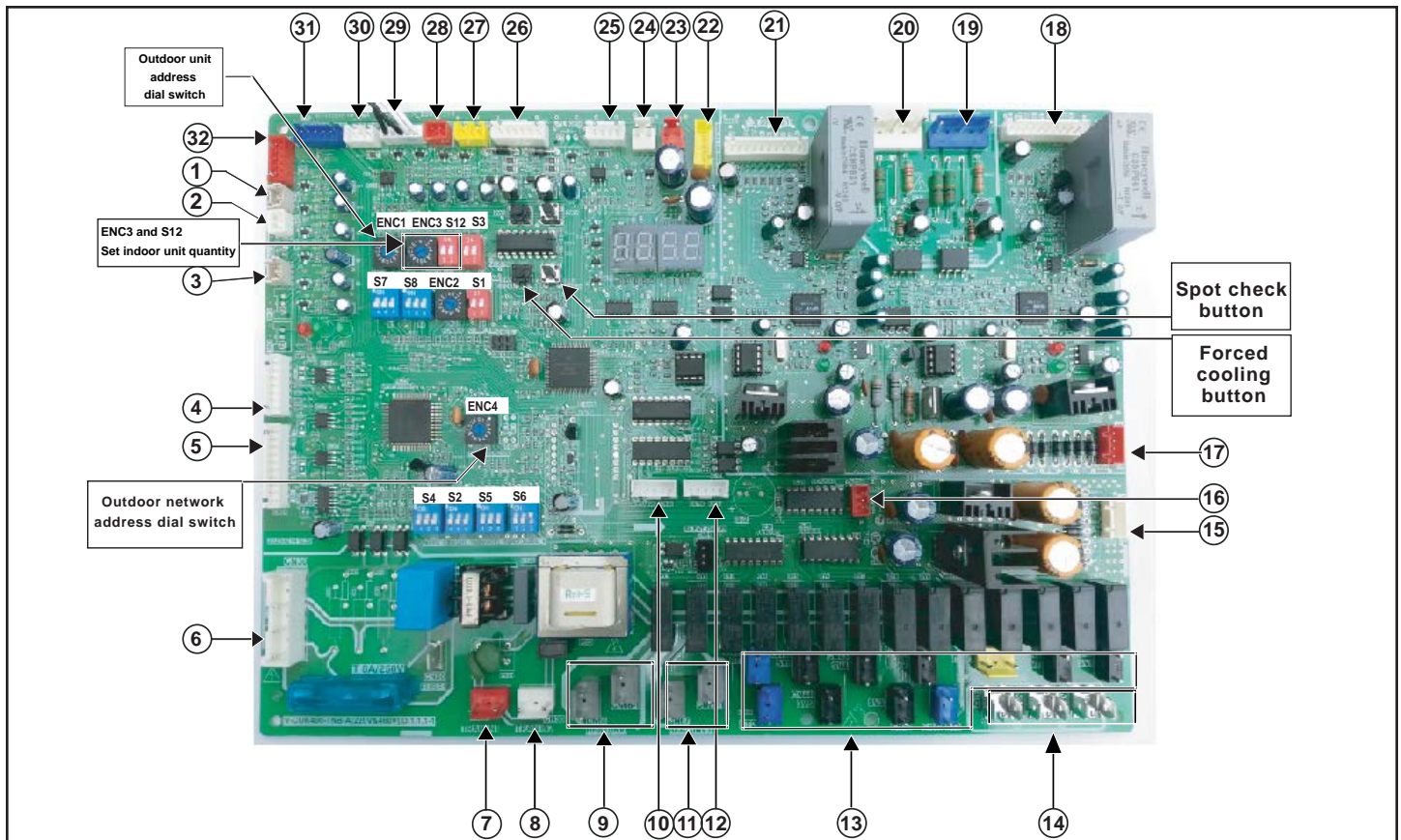

1	Discharge temp. sensor port of inverter compressor A
2	Discharge temp. sensor port of inverter compressor B
3	Heat sink temperature
4	Reserve
5	Wiring port for communication between indoor and outdoor units, indoor unit network, outdoor unit network and network accounting
6	Power port
7	Power input of the No. 1 transformer
8	Power input of the No. 2 transformer
9	Crankcase heater power output port compressor A
10	EXV A driving port
11	Crankcase heater power output port compressor B
12	EXV B driving port
13	Loading output terminal
14	L2 phase power
15	Power output of the No.1 transformer
16	5VDC, 12VDC power port
17	Power output of the No.2 transformer

#	Description
18	Control signal between main board and inverter module B
19	Port for inverter module B voltage inspection
20	Port for inverter module A voltage inspection
21	Control signal between main board and inverter module A
22	5VDC, 12VDC power input
23	Low pressure switch signal port
24	High pressure switch signal port
25	Reserved
26	The current sensor of compressor A and B signal input port
27	High pressure sensor signal input port
28	The temperature sensor of left condenser signal input port
29	The temperature sensor of outdoor ambient and right condenser
30	Communication ports between outdoor units
31	Control port of DC fan B
32	Control port of DC fan A

**Figure 24. VRA144H4M-1 Main Board
208/230V Board Shown**

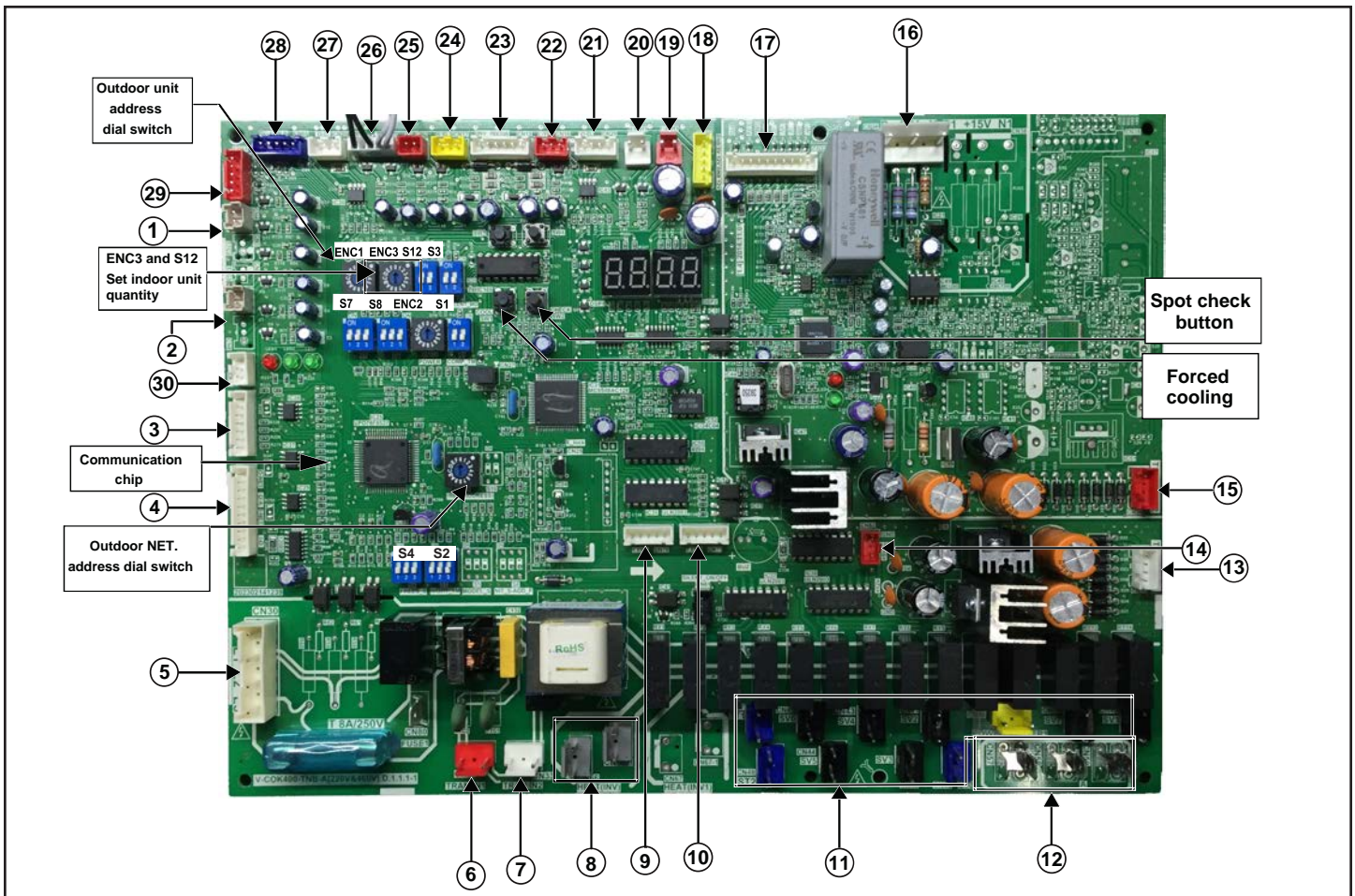

1	Discharge temp. sensor port of inverter compressor A
2	Heat sink temperature.
3	Reserve
4	Wiring port for communication between indoor and outdoor units, indoor unit network, outdoor unit network and network accounting
5	Power port
6	Power input of the No. 1 transformer
7	Power input of the No. 2 transformer
8	Crankcase heater power output port
9	EXV A driving port
10	EXV B driving port
11	Loading output terminal
12	L2 phase power
13	Power output of the No.1 transformer
14	5VDC, 12VDC power port
15	Power output of the No.2 transformer
16	Port for inverter module A voltage inspection

#	Description
17	Activation port of inverter module A
18	Power supply connected port of the main control panel
19	ON/OFF signal input port for system low pressure inspection
20	ON/OFF signal input port for system high pressure inspection
21	Reserve
22	Reserve
23	Current inspection port of the inverter compressors A
24	Input port for system high pressure inspection
25	Port for temperature sensor on left outdoor coils
26	Inspection port for temperature of outdoor ambient and right hand side outdoor coils sensors
27	Communication ports between outdoor units
28	Control port of DC fan B
29	Control port of DC fan A
30	Power supply for communication terminal board

**Figure 25. VRA072H4M-2, VRA096H4M-2, & VRA120H4M-2 Main Board
460V Board Shown**

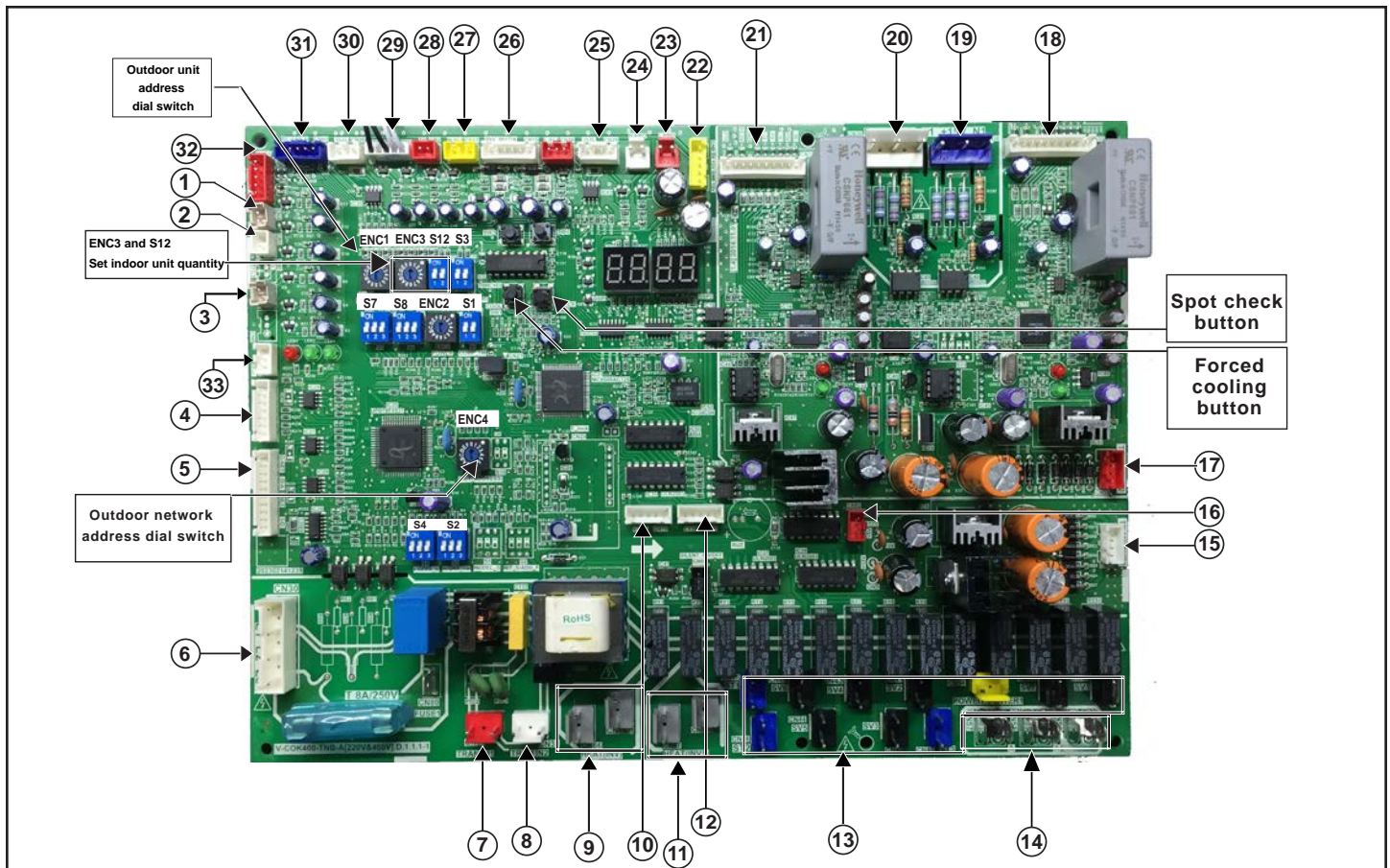

1	Discharge temp. sensor port of inverter compressor A
2	Discharge temp. sensor port of inverter compressor B
3	Heat sink temperature
4	Reserve
5	Wiring port for communication between indoor and outdoor units, indoor unit network, outdoor unit network and network accounting
6	Power port
7	Power input of the No. 1 transformer
8	Power input of the No. 2 transformer
9	Crankcase heater power output port compressor A
10	EXV A driving port
11	Crankcase heater power output port compressor B
12	EXV B driving port
13	Loading output terminal
14	L2 phase power
15	Power output of the No.1 transformer
16	5VDC, 12VDC power port
17	Power output of the No.2 transformer
18	Control signal between main board and inverter module B
19	Port for inverter module B voltage inspection
20	Port for inverter module A voltage inspection
21	Control signal between main board and inverter module A
22	5VDC, 12VDC power input

#	Description
23	Low pressure switch signal port
24	High pressure switch signal port
25	Reserved
26	The current sensor of compressor A and B signal input port
27	High pressure sensor signal input port
28	The temperature sensor of left condenser signal input port
29	The temperature sensor of outdoor ambient and right condenser
30	Communication ports between outdoor units
31	Control port of DC fan B
32	Control port of DC fan A
33	Power supply for communication terminal board

**Figure 26. VRA144H4M-2 Main Board
460V Board Shown**

Table 2. VRA Electrical Data

Model No.	VRA072H4		VRA096H4		VRA120H4		VRA144H4	
	208/230V	460V	208/230V	460V	208/230V	460V	208/230V	460V
Line voltage data - 60 hz - 3 phase								
¹ Maximum Overcurrent Protection (amps)	50	30	60	30	60	30	70	35
² Minimum circuit ampacity	33.6	18.7	36.1	20.0	38.6	21.2	53.8	26
Compressor								
No. of compressors	1	1	1	1	1	1	2	2
Rated load amps	24	14	26	15	28	16	24/16	12/8
Outdoor Fan Motor								
Motor type	DC	DC	DC	DC	DC	DC	DC	DC
No. of motors	2	2	2	2	2	2	2	2
Full load amps	1.8/1.8	0.6/0.6	1.8/1.8	0.6/0.6	1.8/1.8	0.6/0.6	3.9/3.9	1.5/1.5
Input - W	260/260	260/260	260/260	260/260	260/260	260/260	540/540	580/580
Output - W	210/210	210/210	210/210	210/210	210/210	210/210	450/450	450/450

NOTES:

In multiple module systems each outdoor unit requires a separate electrical connection.

Incoming voltage must not be above or below these voltage ranges: 208/230V - 191V minimum, 247V maximum; 460V - 423V minimum , 497V maximum. 2% Maximum line voltage tolerance between phases.

¹ HACR type circuit breaker or fuse.

² Refer to National or Canadian Electrical Code manual to determine wire, fuse and disconnect size requirements.

DIP Switch Functions

S1 Starting Delay Setting

ON		Starting delay is 10 minutes
----	---	------------------------------

ON		Starting delay is 12 minutes (Default factory setting)
----	---	---

S2 Nighttime Selection

ON		Do not adjust without guidance of the Lennox VRF technical support. Incorrect adjustments will affect system performance.
----	---	---

S3 Night Silent Mode Setting

ON		Do not adjust without guidance of the Lennox VRF technical support. Incorrect adjustments will affect system performance.
----	---	---

S4 Static Pressure Setting

ON		Static pressure mode is 0 WG (Default factory setting)
----	---	---

ON		Static pressure mode is low pressure (Reserve position, used for customized unit)
----	--	--

ON		Static pressure mode is medium pressure (Reserve position, used for customized unit)
----	---	---

ON		Static pressure mode is high pressure (Reserve position, used for customized unit)
----	---	---

ENC 1 Outdoor Unit Address Setting

ENC1		Outdoor unit address assignment 0 - Main unit 1 -2 Sub units
------	---	--

ENC 3 and S12 Indoor Unit Address Setting

ENC3	ON		Number of indoor units -- 1-15
------	----	--	--------------------------------

ENC3	ON		Number of indoor units -- 16-31
------	----	--	---------------------------------

ENC3	ON		Number of indoor units -- 32-47
------	----	--	---------------------------------

ENC3	ON		Number of indoor units -- 48-63
------	----	--	---------------------------------

ENC 4 Outdoor Unit Network Address Setting

ENC4		Outdoor network address assignment -- 0-7
------	--	---

NOTE - Dip switch handle location is shown as a solid black box in the tables.

SW2 Query Instructions		
0. - -	Outdoor unit address	0,1, 2 (Network address for centralized control front end.)
1. - -	Outdoor unit capacity	6, 8,10,12 tons (Size of unit)
2. - -	Quantity of outdoor unit modules.	Master outdoor unit. Will read Sub 1 and Sub 2 if available.
3. - -	Outdoor unit operation mode	0-OFF; 2-Cooling; 3-Heating; 4-Forced cooling; 5-Mixed cooling; 6-Mixed Heating
4. - -	Total capacity of outdoor unit	Capacity requirement
5. - -	Cooling capacity	Sub unit only displays capacity of main mode
6. - -	Heating capacity	Sub unit only displays capacity of main mode
7. - -	T4 ambient temperature revision of cooling capacity	
8. - -	T4 ambient temperature revision of heating capacity	
9. - -	The outdoor unit actual operation capacity	Capacity requirement. Will read all ODU's in system and provide available tonnage.
10. - -	Speed of fan A	0-Stop; 1~15: Speed increase gradually, (15 is the max speed)
11. - -	Speed of fan B	0-Stop; 1~15: Speed increase gradually, (15 is the max speed)
12. - -	T2 average temperature	Actual value (Average indoor coil temp cooling.)
13. - -	T2B average temperature	Actual value (Average indoor coil temp heating.)
14. - -	Left hand side condenser temperature sensor – T3	Actual value
15. - -	Right hand side condenser temperature sensor – T5	Actual value
16. - -	T4 outdoor ambient temperature	Actual value (celsius)
17. - -	Discharge temperature of inverter compressor A	Actual value
18. - -	Discharge temperature of inverter compressor B	Actual value
19. - -	Inverter module temperature	Actual value
20. - -	Saturated temperature corresponding to the discharge pressure	Actual value + 30
21. - -	Minimum discharge superheat	Actual value
22. - -	Current of inverter compressor A	Actual value (amp draw)
23. - -	Current of inverter compressor B	Actual value (amp draw)
24. - -	State of the evaporator or condenser	0-All condenser; 1-Left evaporator/right condenser; 2-All evaporator.
25. - -	Opening of EXV A	Actual value ÷ 8
26. - -	Opening of EXV B	Actual value ÷ 8
27. - -	High pressure	Actual value x 10
28. - -	Quantity of Indoor units	ENC3 dial switch value
29. - -	Quantity of Indoor units in cooling	Actual value
30. - -	Quantity of Indoor units in heating	Actual value
31. - -	Reserve	
32. - -	Noise control mode	0, 1, 2, 3
33. - -	Reserve	
34. - -	Reserve	
35. - -	Reserve	
36. - -	Reserve	
37. - - - -	Last alarm code. If no alarm code, displays 888.	Press SW4 then SW3 to retrieve fault history.
38. - - - -	Remove fault number of times	
39. - - - -	- - - -	Check end

*Units of temperature are shown as °C, units of pressure are shown as MPa.

NOTES - Normal display: When in standby mode, the left position displays the address of the outdoor unit and the right position displays the quantity of indoor units that can communicate with the outdoor unit.

When the compressor is operating, the LED display shows the rotation frequency of the compressor.

Electrical Installation for Indoor and Outdoor Units

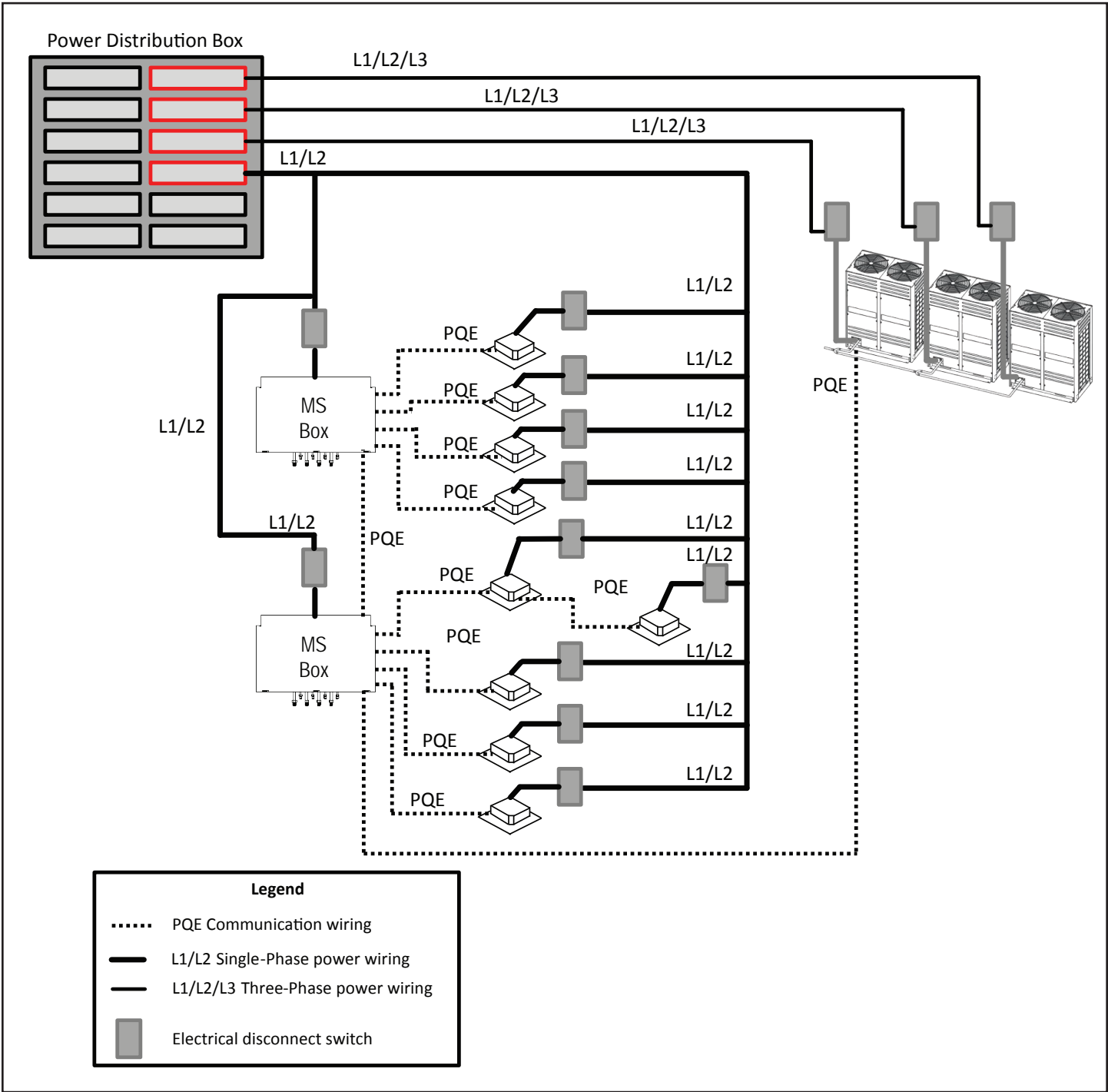

Figure 27. VRA Typical Power Wiring

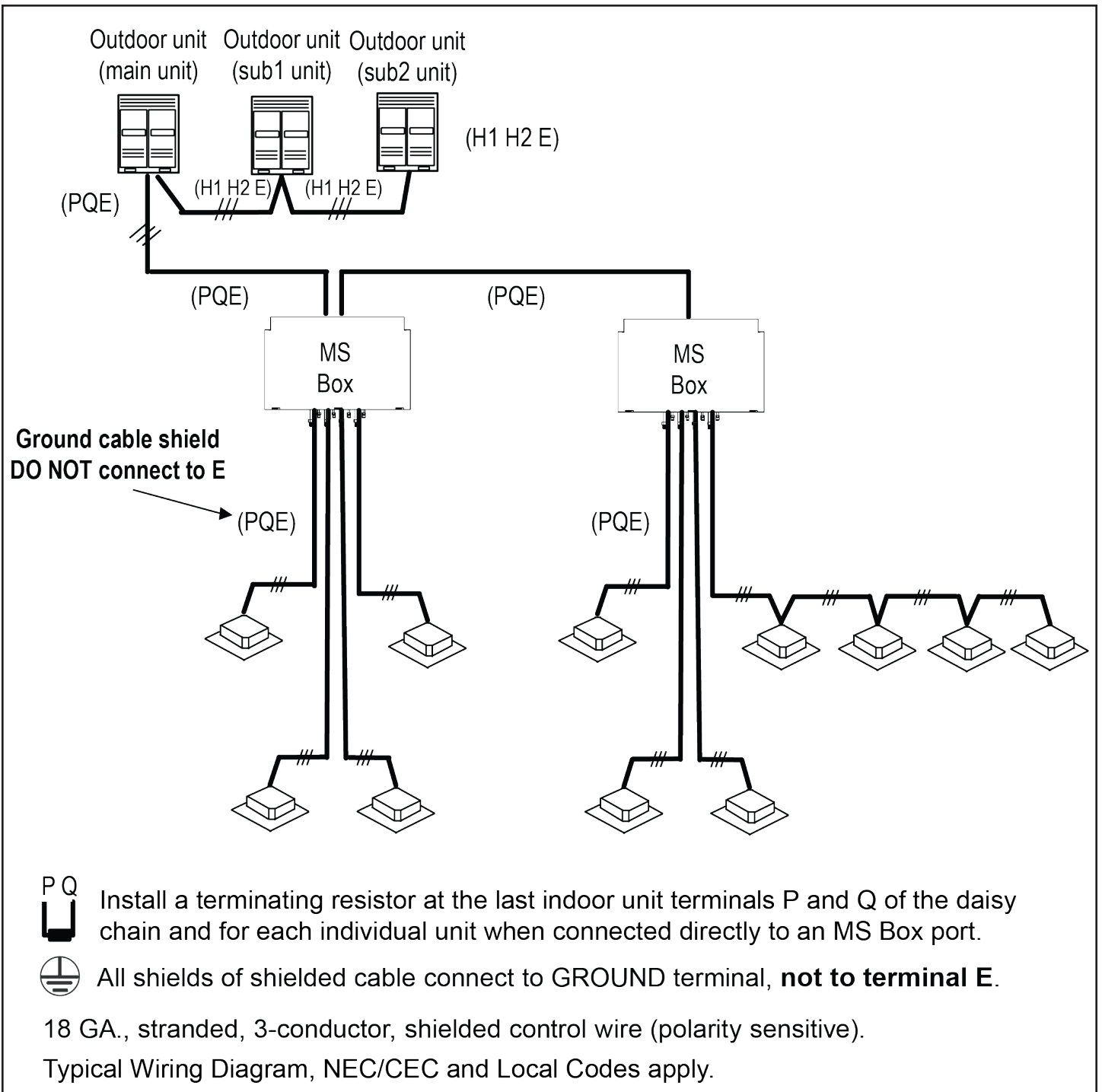

Figure 28. VRA Heat Recovery Typical Control Wiring

Trial Run

Before operation, remove the six (6) pieces of PE foam which are used at the rear of the unit for protecting the outdoor coils. Be careful not to damage the fin; otherwise, the heat exchange performance may be affected. Also remove the PE foam which is used inside the front right hand side panel adjacent to the compressor.

Precautions Before Start Up

- Confirm that refrigeration piping and communication wiring of the indoor and outdoor units have been connected to the same refrigeration system.
- Check and confirm that incoming voltage must not be above or below these voltage ranges: 208/230V - 191V minimum, 247V maximum; 460V - 423V minimum, 497V maximum. 2% Maximum line voltage tolerance between phases.
- Check and confirm that the power wire and control wire are correctly connected.
- Check whether wired controller is properly connected.
- Before power up, confirm there is no short circuit to ground.

- Check whether all units have passed nitrogen pressure test for 24 hours at recommended pressure rating.
- Confirm whether the system has been evacuated.
- Calculate the additional refrigerant charge for each system according to the actual length of liquid pipe and add as necessary.
- Have system plan, system piping diagram and control wiring diagrams on hand for reference.
- Record the setting address code on the system plan.
- Turn on power to outdoor unit for 12 hours for crank case heater to warm the oil in the compressor.
- Ensure all necessary service valves are open.
- All dial codes and DIP switches of indoor and outdoor unit have been set according to the technical requirement of product, see the indoor unit manual for information about the indoor unit.

Identify Name of Each System

- To clearly identify the connected systems between two or more indoor units and outdoor unit, select names for every system and record them on the nameplate on the outdoor electric control box cover.

Technical Support

1-844-GET-VRF1

(1-844-438-8731)

vrftechsupport@lennoxind.com

www.LennoxVRF.com

Download the app
from the Apple App Store or the Google Play store.

