

# AIR CONDITIONER COIL REPLACEMENT KIT

## INSTALLATION INSTRUCTIONS FOR AIR CONDITIONER ALUMINUM COIL REPLACEMENT KITS

### Shipping and Packing List

Package 1 of 1 contains:

- 1 – Coil assembly
- 1 – Bag assembly
  - 1 – Installation instruction
  - 1 – 1/2" coupling
  - 1 – Discharge line

Check the replacement coil for shipping damage. If you find any damage, immediately contact the last carrier.

### **⚠ WARNING**

Improper installation, adjustment, alteration, service or maintenance can cause property damage, personal injury or loss of life. Installation and service must be performed by a licensed professional HVAC installer or equivalent, service agency, or the gas supplier.

### **⚠ CAUTION**

As with any mechanical equipment, contact with sharp sheet metal edges can result in personal injury. Take care while handling this equipment and wear gloves and protective clothing.

### **⚠ WARNING**

To prevent personal injury, as well as damage to panels, unit or structure, observe the following: While installing or servicing this unit, carefully stow all removed panels so that the panels will not cause injury to personnel, objects or nearby structures. Also, take care to store panels where they will not be subject to damage (e.g., being bent or scratched). While handling or stowing the panels, consider any weather conditions (especially wind) that may cause panels to be blown around and damaged.

### **⚠ WARNING**



Electric Shock Hazard. Can cause injury or death. Unit must be properly grounded in accordance with national and local codes. Line voltage is present at all components when unit is not in operation on units with single-pole contactors. Disconnect all remote electric power supplies before opening access panel. Unit may have multiple power supplies.

### Requirements

Verify that the new coil has holding charge. Remove the cap from the discharge line and press the valve core. The coil should have approximately 10 psi dry air holding charge. If there is no charge, repressurize the coil and check for leaks.

Verify that the liquid and discharge manifold position matches that of the existing coil before removing original coil. Take care not to damage the liquid line stub.



FIGURE 1. Aluminum Replacement Coil

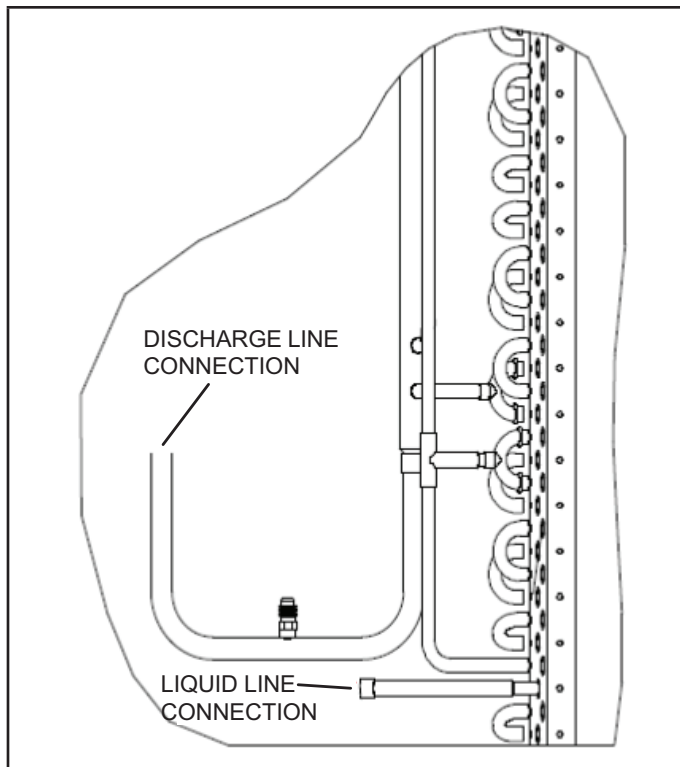

**FIGURE 2. Manifold-Style Replacement Coil**

### Installation

## **⚠ CAUTION**

Before attempting to perform any service or maintenance, turn the electrical power to unit OFF at disconnect switch.

## **⚠ IMPORTANT**

The stub of the coil must be secured if any adjustments to the liquid line are needed. Do not allow it to move.

- 1 - Disconnect all power to the unit.
- 2 - Reclaim the refrigerant from the unit.
- 3 - Remove access panel, side (louvered) panels, top panel, and corner posts. Remove the screws that attach the coil endplate to the control box and compressor enclosure. Keep the screws.

- 4 - Unscrew the liquid service and suction valve brackets from the corner mullion. Braze off the liquid line at the swaged joint next to the existing coil outlet.
- 5 - Use a tubing cutter to cut the discharge line at the optimal location to facilitate the installation of the new coil.
- 6 - Remove the existing coil.
- 7 - Place replacement coil assembly inside cabinet.
- 8 - Remove the holding charge by pressing the valve core. Use a tubing cutter to cut off the discharge line to facilitate the installation of the new coil.

## **⚠ IMPORTANT**

Apply a wet cloth to the factory copper-to-aluminum joints and the pressure switch to prevent heat damage when brazing in the field copper-to-copper joints for the replacement coil. See figure 3.

- 9 - Install new discharge line. See figure 3 for important precautions regarding brazing. Align the discharge line on the replacement coil with the discharge line from the compressor. Install the provided coupling between the two tubes. Braze the coupling into place.
- 10 - Braze in the liquid line if required. Reattach the liquid and suction service valves.
- 11 - Replace the screws that attach the coil endplate to the control box and compressor enclosure.
- 12 - Replace applicable corner posts, side (louvered) panels and top panel.
- 13 - Refer to the unit installation instructions for leak testing, evacuation and start-up procedures. Charge the unit as outlined in the installation instructions or according to the charging sticker.
- 14 - Once installation of the replacement coil is complete, confirm that all refrigerant tubing and wiring is properly routed away from other wiring and sharp metal edges.
- 15 - Replace access panel.

# IMPORTANT

**OBSERVE THE FOLLOWING PRECAUTIONS TO PREVENT DAMAGE TO ALUMINUM SOLDER JOINTS OR PRESSURE SWITCH AND TRANSDUCER WHEN REPLACING AN ALUMINUM OUTDOOR COIL**

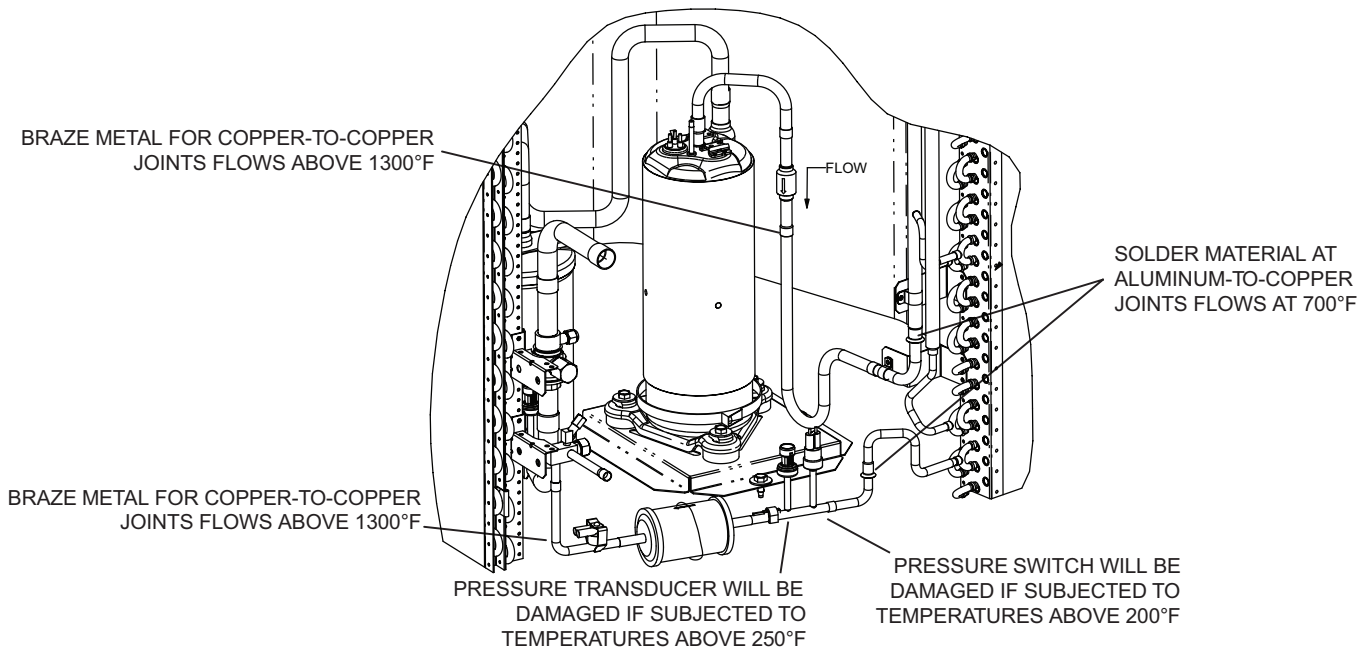

**TO PREVENT DAMAGE TO ALUMINUM SOLDER JOINTS OR PRESSURE SWITCH AND TRANSDUCER, WET RAGS AND / OR THERMAL TRAP PASTE MUST BE APPLIED TO THE AREAS HIGHLIGHTED BELOW BEFORE BRAZING. WET RAGS MUST BE LEFT ON PROTECTED AREAS UNTIL BRAZED JOINTS HAVE COOLED DOWN TO AMBIENT TEMPERATURE TO PREVENT MIGRATION OF HEAT INTO THE ALUMINUM SOLDERED JOINTS OR PRESSURE SWITCH AND TRANSDUCER.**

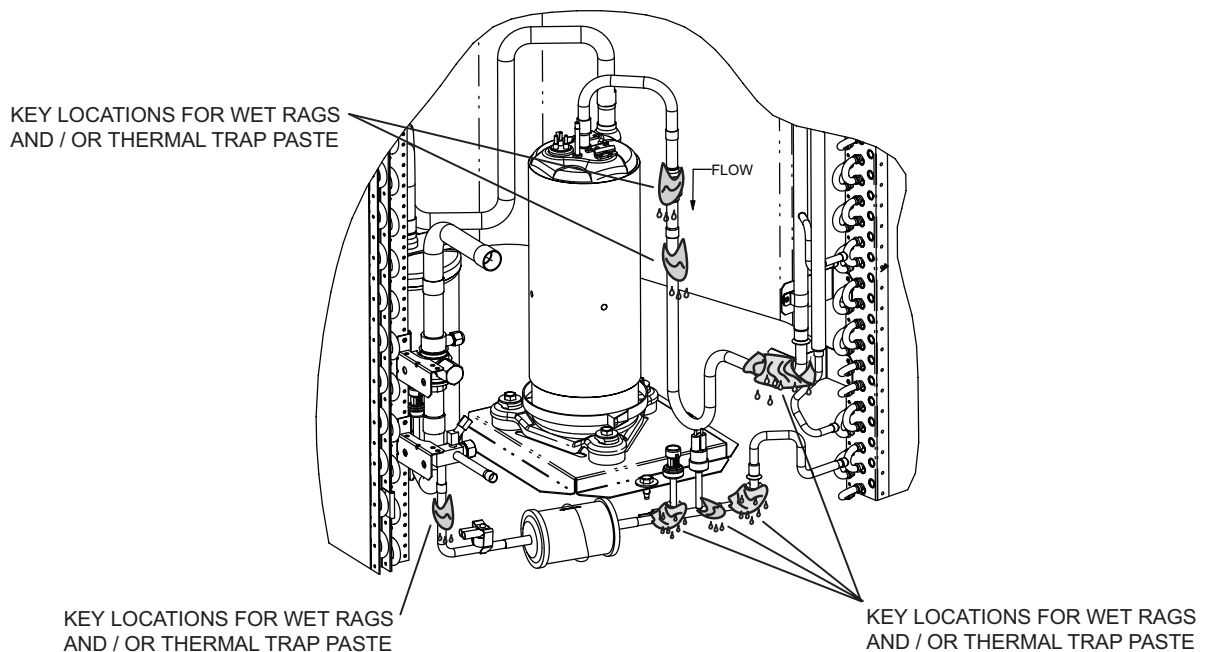

**FIGURE 3. Important Precautions for Coil Installation**