

PACKAGED UNITS KITS AND ACCESSORIES

507586-03
12/2020
Supersedes 507586-02

NATURAL TO LP (PROPANE) GAS CHANGEOVER KIT

INSTALLATION INSTRUCTIONS FOR LP KIT USED ON LGM/LGH/KG/ZG/SG 024-090 PACKAGED ROOFTOP UNITS

⚠ WARNING

This conversion kit is to be installed by a qualified service agency in accordance with the manufacturer's instructions and all applicable codes and requirements of the authority having jurisdiction. If the information in these instructions is not followed exactly, a fire, an explosion or production of carbon monoxide may result causing property damage, personal injury or loss of life. The qualified service agency is responsible for the proper installation of this kit. The installation is not property and complete until the operation of the converted appliance is checked as specified in the manufacturer's instructions supplies with the kit.

Shipping and Packing List

Package 1 of 1 contains:

- 7 - Orifices (3 in 21A01)
- 1- Spring kit (2 in 14N21 & 21A02)
- 1- Bag assembly containing:
 - 3-Conversion plates (1 in 21A02)
 - 1-Conversion sticker
 - 1-Acrylic sheet
 - 1-J/P19 harness (14N21 & 21A01 only)

Requirements

This conversion kit shall be installed by a qualified service agency. A qualified service agency is any individual, firm, corporation or company which either in person or through a representative is engaged in and is responsible for the

connection, installation, repair or servicing of gas utilization equipment or accessories, who is experienced in such work, familiar with all precautions required, and has complied with all the requirements of the authority having jurisdiction.

Canadian installations only - The conversion shall be carried out in accordance with the requirements of the Provincial authorities having jurisdiction and in accordance with the requirements of the CAN/CGA-B149.1 and .2 Installation Code.

⚠ WARNING

Improper installation, adjustment, alteration, service or maintenance can cause property damage, personal injury or loss of life. Installation and service must be performed by a licensed professional installer (or equivalent), service agency or the gas supplier.

Application

The LP/propane gas changeover kit is required for gas conversion as shown in table 1. The 10th character on the unit nameplate determines the type of gas valve. For example, ZGA060S4BH1G would contain a two-stage, high heat gas valve.

Installation

- 1 - Turn main manual shut-off valve off and turn off electrical supply to unit. Set thermostat to "Off" position.
- 2 - Open access panels as shown in figure 1. On LGM/LGH/KG/SG units, remove the mullion between the heat and compressors sections.

TABLE 1- KIT APPLICATION

Unit	Cat. No.	Part No.	Htg. Stages	10th Character
LGH036-072S, KG 024-090, ZG 036-074	14N20	614839-01	Single-Stage	S, M, T, W, Y, Z
LGM/LGH036-072S/H/U, KG 024-090, ZG 036-074, SG 036 & 060	14N21	614839-02	Two-Stage Med & High	H, U, Q, X
LGM/LGH036-072H, LGM/LGH036-074U, SG 036 & 060	21A01	614839-03	Two-Stage Standard	B
LGH048-074U, LGH060H	21A02	614839-04	Four-Stage High	D

⚠ CAUTION

As with any mechanical equipment, personal injury can result from contact with sharp sheet metal edges. Be careful when you handle this equipment.

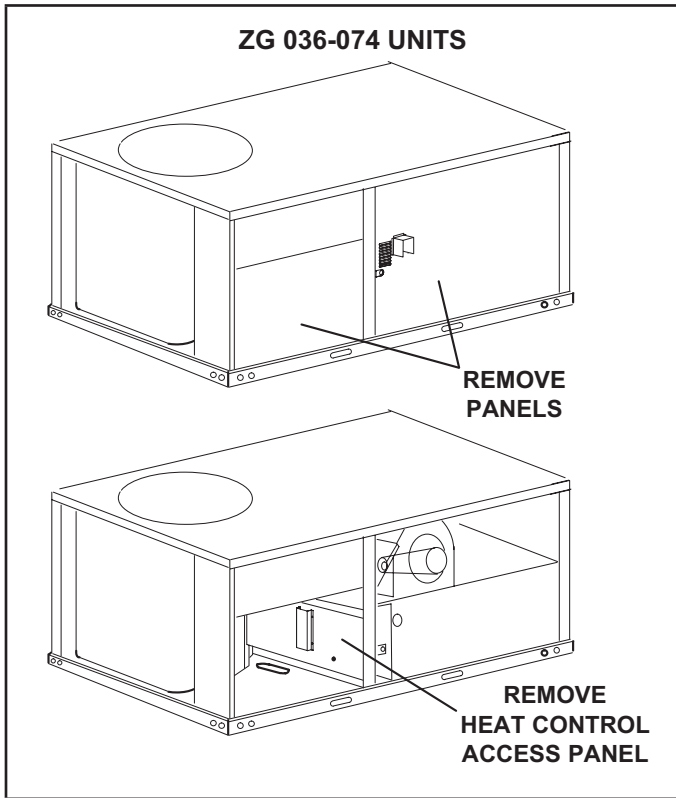

Figure 1

IMPORTANT-The gas supply shall be shut off prior to disconnecting the electrical power, before proceeding with this conversion.

- 3 - Remove and retain four screws securing manifold to burner box; remove manifold. See figure 2, 3, 4, or 5.
- 4 - Remove orifices from manifold and install the orifices provided in kit. Unit will have 3, 5, or 7 burners. Replace only the orifices which have a burner installed.

On four-stage units only, the two left orifices are 0.050" and the right five orifices are 0.052". See figure 4 for proper orifice placement.

CAUTION - Tighten orifices with pipe threads to 6.25 ft.lbs. Do not overtighten.

IMPORTANT - Do not use thread compound on gas orifices.

- 5 - Replace the manifold and secure with retained screws.
- 6 - Install spring kit as shown in figure 6 for single-stage gas valves, figure 7 for two-stage and four-stage White Rodgers gas valves, and figure 8 for two-stage Honeywell gas valves. Also refer to the manufacturer's instructions provided with spring kit. When installing 14N21 kit, discard the unused spring kit.

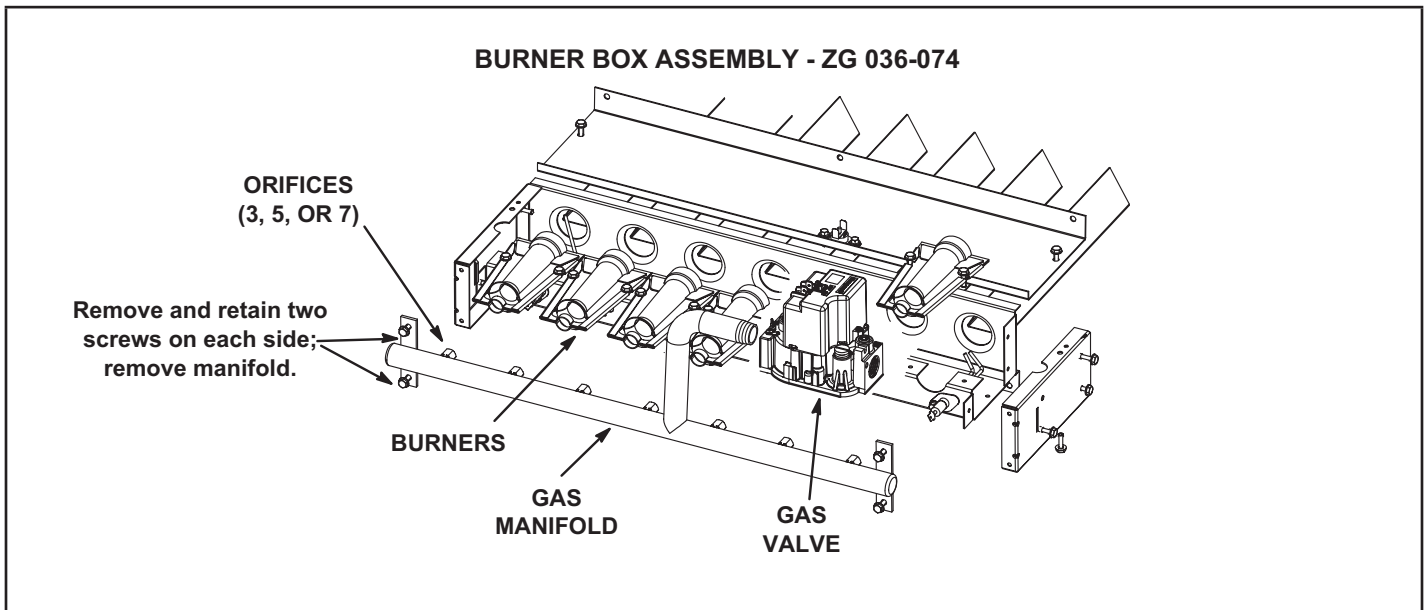

Figure 2

BURNER BOX ASSEMBLY - LGM/LGH/KG 024-090

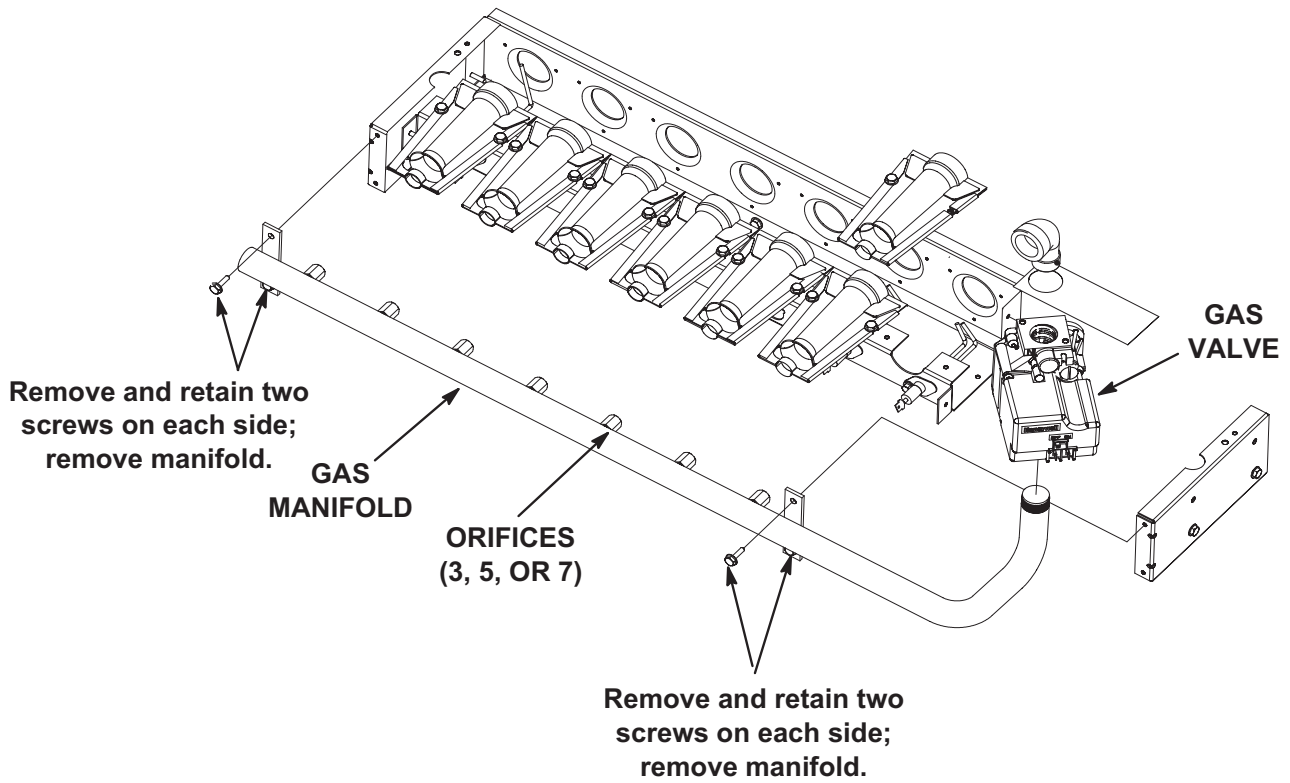

Figure 3

BURNER BOX ASSEMBLY - LGH 036, 048, 060, 074U - FOUR-STAGE HEAT

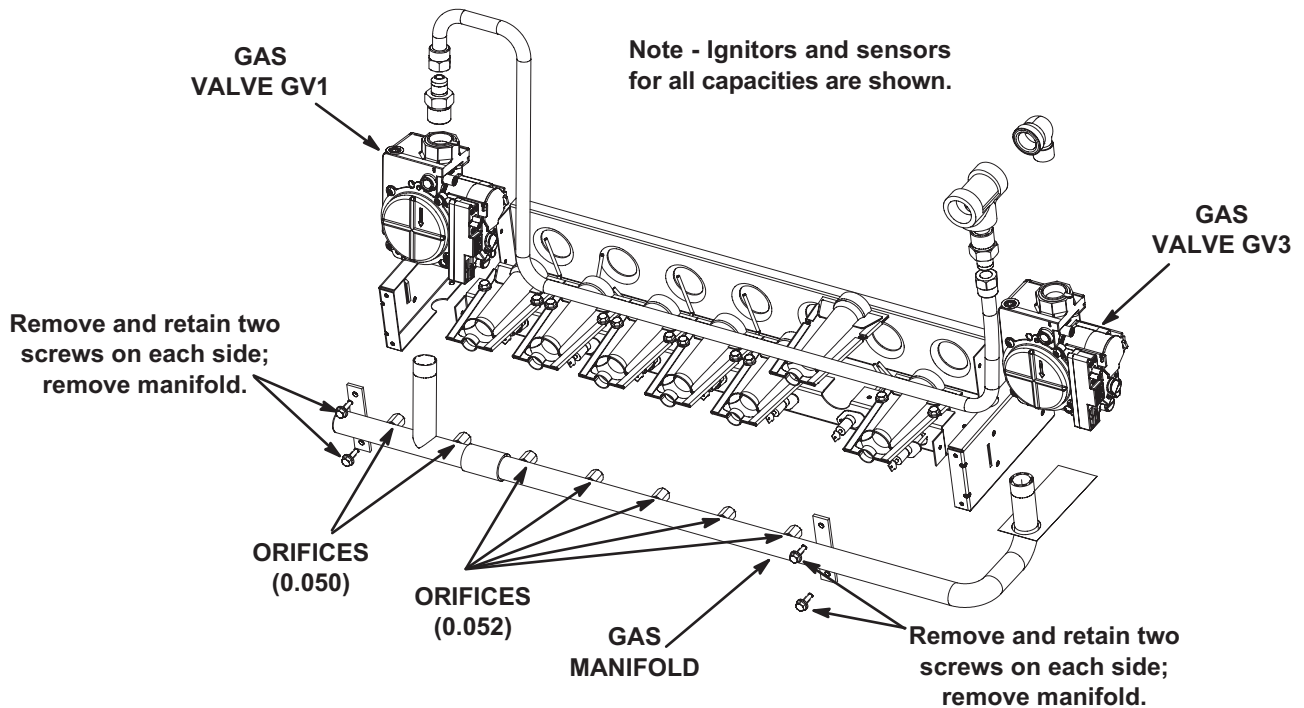

Figure 4

BURNER BOX ASSEMBLY - SG 036 & 060

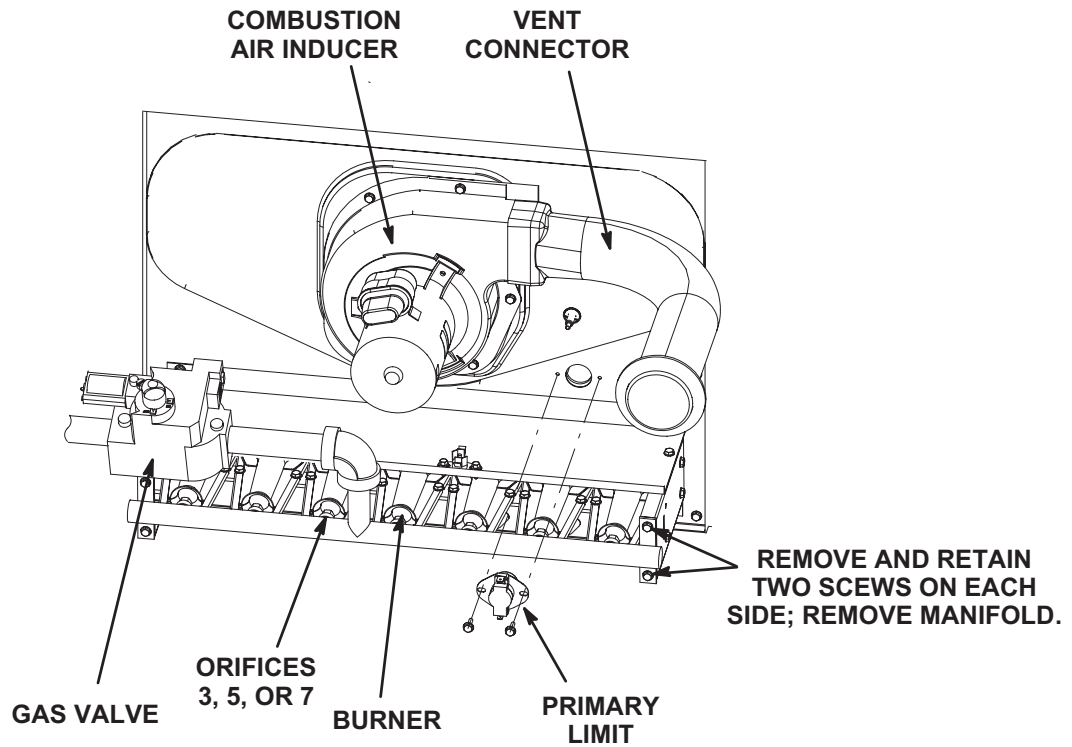

Figure 5

CONVERTING SINGLE-STAGE GAS VALVE (Natural to LP)

1. Remove regulator cap screw and pressure regulator adjusting screw.
2. Remove existing spring.
3. Insert replacement spring.
4. Install the new plastic pressure regulator adjusting screw so that the top of the screw is flush (level) with the top of the regulator. Turn the pressure regulator adjusting screw clockwise six complete turns. This adjustment provides a preliminary pressure setting of about 10.5" w.c. (2.6 kPa) for the LP regulator.
5. Check regulator setting either with a manometer or by clocking the gas meter.
6. Reinstall cap screw.

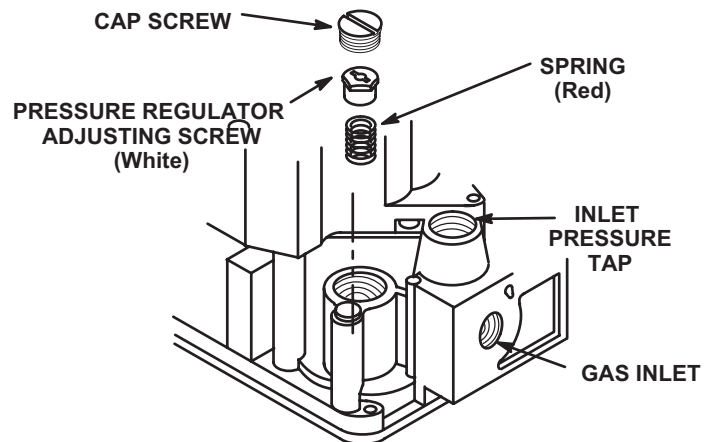

Figure 6

CONVERTING TWO- & FOUR-STG. GAS VALVES (White Rodgers Natural to LP/Propane)

- 1- Remove both high fire and low fire springs from the gas valve.
- 2- Replace both high fire and low fire springs with the provided LP springs color-coded white.
- 3- Install the high fire adjustment screw and adjust approximately 12 turns.
- 4- Install the low fire adjustment screw and adjust approximately 8 turns.
- 5- Install both regulator screw covers.

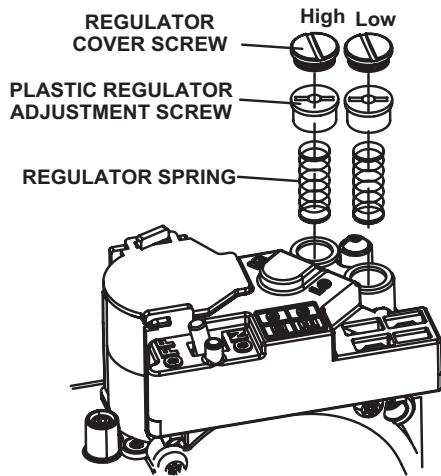

Figure 7

CONVERTING TWO-STAGE GAS VALVE (Honeywell Natural to LP/Propane)

1. Turn off the gas supply to the unit.
2. Remove the pressure regulator cover assembly. See the gas valve illustration below.
3. Remove the existing stem/spring assembly.
4. Insert the replacement stem/spring assembly.
5. Replace the pressure regulator cover assembly and tighten the screws.
6. Apply the conversion label to the gas control.

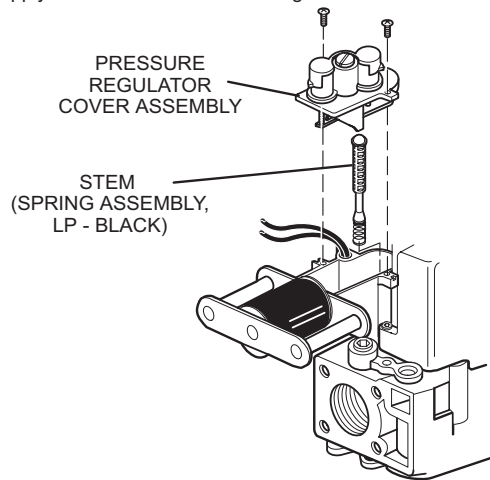

Figure 8

Install J/P19 Jumper Harness

Two Stage Gas Valves Only

- 1 - Locate J19/P19 combustion air blower connectors in divider panel between heat and compressor sections.
- 2 - Disconnect J19/P19.
- 3 - Install kit harness between disconnected plugs. See figure 9.

INSTALL JUMPER PLUG

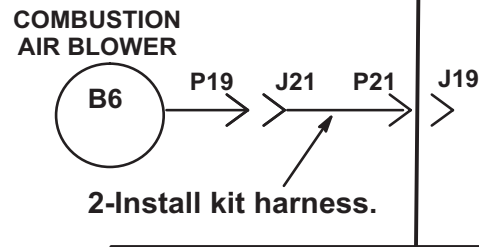
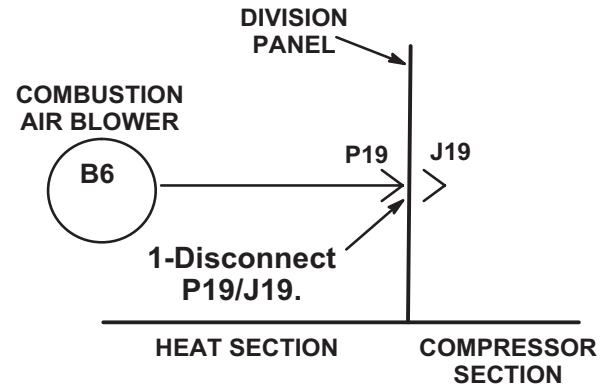

Figure 9

Start-Up and Adjustment

- 1 - Replace heat section access panels and mullion.
- 2 - Close heat section access panel.

A - To place unit in operation:

- 1 - Turn main manual shut-off valve on.

WARNING



Danger of explosion. Can cause injury or death. Do not attempt to light manually. Unit has a direct spark ignition system.

- 2 - Wait five minutes, then open manual knob on gas valve and replace compressor access panel.
- 3 - Restore electrical supply to unit and set fan switch to "Auto" or "On." Move system selection switch to "Heat" and adjust thermostat setting above room temperature.
- 4 - The combustion air blower will start and burners will light within 40 seconds.
- 5 - If burners do not light first time (gas line not fully purged), ignition system will attempt to light two more times before locking out gas valve operation.
- 6 - If lockout occurs, repeat steps 1, 2 and 3 above.

B - To shut down unit operation:

- 1 - Set thermostat selection switch to "Off" position, remove heat control access panel and turn manual knob on gas valve to "Off" position.
- 2 - Replace heat control access panel.

C-Heating Adjustment

Check gas line pressure with unit firing at maximum rate. A minimum of 10.8" w.c., and a maximum of 13.5" w.c. should be maintained. Manifold pressure is preset as shown on the appropriate conversion label provided in this kit.

No adjustment should be necessary. On multiple unit installations, each unit should be checked in sequence beginning with the one closest to the supply gas main and progressing to the one furthest from the main.

Identifying Unit As LP Converted

- 1 - Locate 580207-04, -05, and -08 conversion plate labels provided in kit. Select the appropriate label and discard the other two labels.

Note - 21A02 kits have one conversion plate; there are no further labels to discard.

- 2 - Make a check mark in the appropriate box on the conversion plate corresponding to unit model number shown on nameplate. Affix appropriate conversion plate near unit nameplate.
- 3 - Complete installer information on converter sticker and affix to vestibule panel. Affix acrylic sheet over converter sticker.