



©2021 Lennox Industries
Dallas Texas, USA

GAS UNITS KITS & ACCESSORIES

507588-05
01/ 2021
Supersedes 507588-04

GAS AND PRESSURE SWITCH CONVERSION KIT

INSTALLATION INSTRUCTIONS FOR NATURAL TO LP/PROPANE AND PRESSURE SWITCH KIT 17H63 USED WITH ML196UHE030, EL195UHE030 AND EL196UHE030 MODEL UNITS

⚠ WARNING

This conversion kit is to be installed by a licensed professional service technician (or equivalent) or other qualified agency in accordance with the manufacturer's instructions, all codes and requirements of the authority having jurisdiction in the USA, and the requirements of the CSA-B149 installation codes in Canada. If the information in these instructions is not followed exactly, a fire or explosion may result causing property damage, personal injury or loss of life. The qualified agency performing this work assumes responsibility for this conversion.

Shipping and Packing List

Package 1 of 1 contains:

- 4 - Main burner orifices (0.028)
- 1 - Gas conversion sticker
- 1 - Nameplate conversion sticker
- 1 - Pressure switch (0.90)
- 1 - Bag assembly containing:
 - 1 - Pressure switch
 - 1 - Gas valve regulator spring
 - 1 - Low gas inlet pressure switch (S145)
 - 1 - Gas valve inlet fitting
 - 1 - Wiring harness

Application

Use natural to LP/Propane gas conversion kit 17H63 to convert ML196UHE030, EL195UHE030 and EL196UHE030 units from natural gas to LP/Propane.

⚠ WARNING

Danger of explosion.

There are circumstances in which odorant used with LP/propane gas can lose its scent. In case of a leak, LP/propane gas will settle close to the floor and may be difficult to smell. An LP/propane leak detector should be installed in all LP applications.

⚠ CAUTION

As with any mechanical equipment, contact with sharp sheet metal edges can result in personal injury. Take care while handling this equipment and wear gloves and protective clothing.

⚠ CAUTION

Gas valve conversion kit **MUST** be installed **BEFORE** the unit is fired using LP/propane gas. Unit damage **WILL OCCUR** if the unit is fired using LP/ propane gas with the original natural gas orifices.

Installation

- 1 - Set thermostat to lowest setting. The gas supply must be shut off prior to disconnecting the electrical power and proceeding with the conversion.
- 2 - Remove the heating compartment access panel. Turn the automatic gas valve switch to the OFF position. See figure 1.
- 3 - Disconnect the gas supply and the two wires at the gas valve.
- 4 - Remove the burner box cover (if equipped). Remove the four manifold securing screws. Slide the manifold/gas valve assembly out of the burner box.

⚠ IMPORTANT

DO NOT use pipe dope or any pipe sealant on gas orifice threads.

- 5 - Replace the burner orifices with the provided gas orifices. Torque to approximately 35 in-lbs. Do not use sealant on orifices. Figure 5 shows manifold/gas valve assembly.
- 6 - Replace the gas valve regulator spring with the provided regulator spring. See figure 6.
- 7 - Re-install the manifold/valve assembly.
- 8 - Thread provided fitting to gas valve inlet until hand tight. Using properly sized wrench, tighten fitting 2 to 3 full turns being careful to position the side port to allow clearance for the pressure switch and harness. See figure 2 or 3.



NOTE - Never use channel lock pliers or a pipe wrench on the brass fitting.

NOTE - Some installations may require the pressure switch and fitting assembly to be positioned differently than shown in figure 2 and 3.

NOTE - Do not over tighten. (Maximum 3 full turns past hand tight for ½" NPT per ASME B1.20.1-2013)

- 9 - Thread the gas supply to the fitting until hand tight. A field provided coupling may be needed. See figure 3. Using properly sized wrench to support fitting, tighten supply line into fitting 2 to 3 full turns to achieve leak free joint.
- 10 - Thread pressure switch (S145) to fitting 2 to 3 turns past hand tight, then wire as shown in figure 7.
- 11 - Restore the electrical power to the unit.
- 12 - Inspect all sides of assembly. Turn on gas supply. **Immediately check the entire fitting surface and assembly joints for gas leaks.**
- 13 - Affix nameplate conversion sticker next to unit nameplate.
- 14 - Complete the information required on the gas converter sticker: date, name, and address. Affix sticker to the exterior of the unit in a visible area.
- 15 - Remove the wires from the pressure switch and the tubing from the negative side (red and black or red) and positive side (black) of the pressure switch (leave tubing connected to cold end header box). See figure 4.
- 16 - Remove existing pressure switch. Switch and bracket will snap off the cold end header box.
- 17 - Install the provided pressure switch back in place on the cold end header box and connect wires and tubing removed from step 15.
- 18 - Follow the steps given in the start-up and adjustment section.

⚠ IMPORTANT

Carefully check all piping connection for gas leaks. **DO NOT** use matches, candles, open flames or other means of ignition to check for gas leaks. Use a soap solution or other preferred means.

⚠ CAUTION

Some soaps used for leak detection are corrosive to certain metals. Carefully rinse piping thoroughly after leak test has been completed.

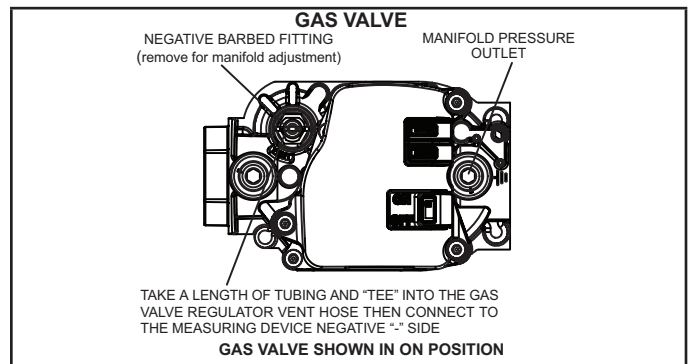

FIGURE 1

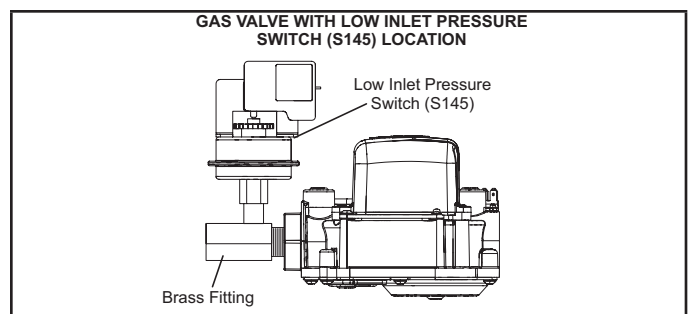

FIGURE 2

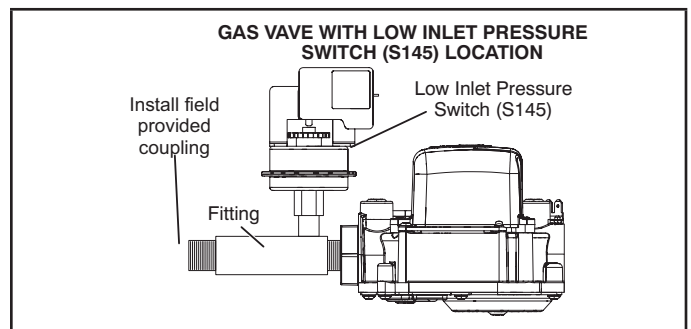

FIGURE 3

Pressure Switch Replacement

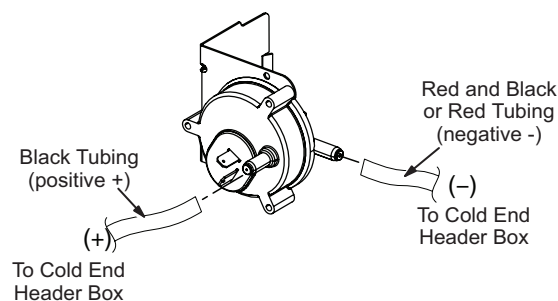

FIGURE 4

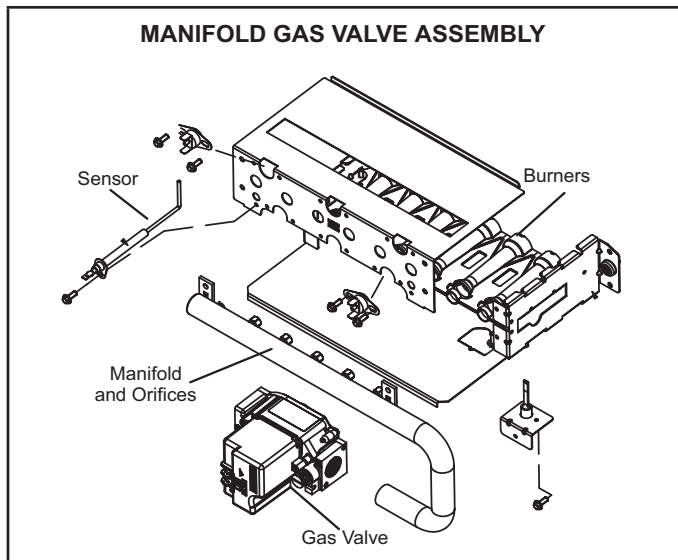

FIGURE 5

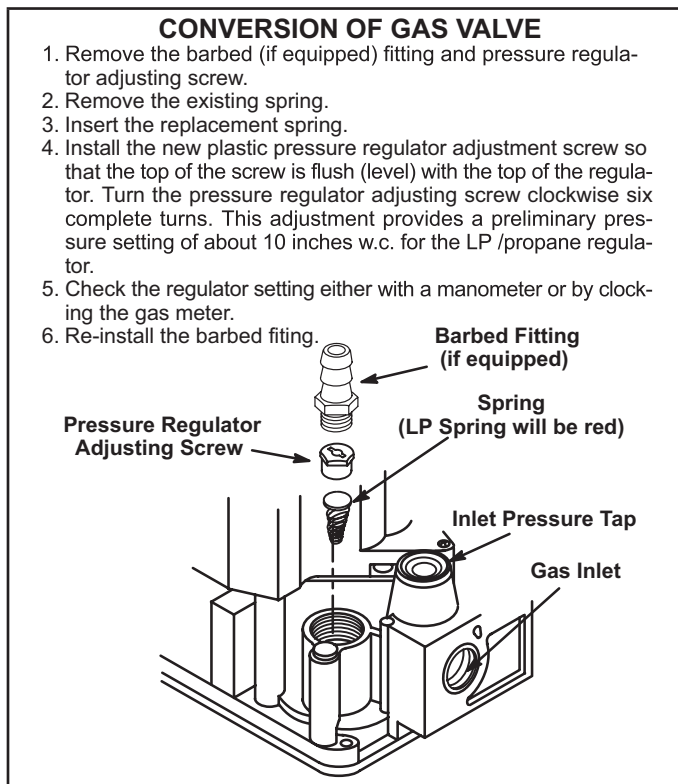

FIGURE 6

Start-Up & Adjustment

BEFORE LIGHTING - Smell all around the appliance area for gas. Be sure to smell next to the floor because LP/ Propane gas is heavier than air and will settle on the floor.

Use only your hand to move the gas control switch. Never use tools. If the switch will not move by hand, do not try to repair it. Force or attempted repair may result in a fire or explosion.

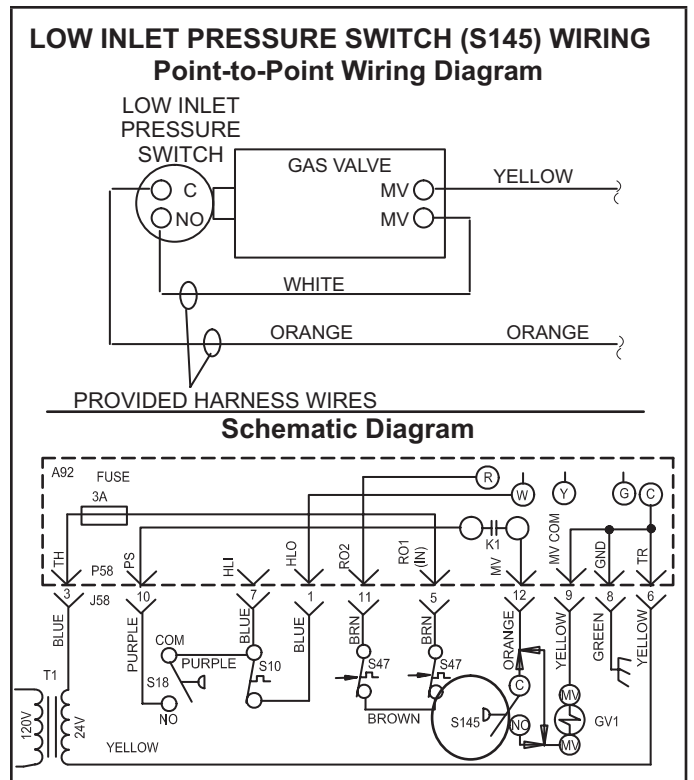

FIGURE 7

A - Placing the Unit into Operation

⚠ IMPORTANT

Follow the lighting instructions provided on the unit. If lighting instructions are not available, refer to the following section.

Units are equipped with a hot surface ignition system. The ignition system automatically lights the burners each time the thermostat calls for heat.

- 1 - **STOP!** Read the safety information at the beginning of this section.
- 2 - Set the thermostat to its lowest setting.
- 3 - Turn off all electrical power to the furnace.
- 4 - Do not try to light the burners by hand.
- 5 - Remove the unit access panel.
- 6 - Move gas valve switch to **OFF**. See figure 1.
- 7 - Wait five (5) minutes for any gas to clear out. If you then smell gas, **STOP!** Immediately call your gas supplier from a neighbor's phone. Follow the gas supplier's instructions. If you do not smell gas, go to the next step.
- 8 - Move gas valve switch to **ON**. See figure 1.
- 9 - Replace the unit access panel.
- 10 - Turn on all electrical power to the unit.

- 11 - Set the thermostat to desired setting.
- 12 - If the furnace will not operate, see the section "Turning Gas Off to the Unit" and call your the gas supplier.

Gas Pressure Measurement

A - Gas Flow (Approximate)

TABLE 1

GAS METER CLOCKING CHART				
Unit	Seconds for One Revolution			
	Natural		LP Propane	
	1 cu ft Dial	2 cu ft Dial	1 cu ft Dial	2 cu ft Dial
-030	120	240	300	600
Natural-1000 btu/cu ft			LP-2500 btu/cu ft	

Furnace should operate at least 5 minutes before checking gas flow. Determine time in seconds for two revolutions of gas through the meter. (Two revolutions assures a more accurate time.) **Divide by two** and compare to time in table 1 below. If manifold pressure matches table 2 and rate is incorrect, check gas orifices for proper size and restriction. Remove temporary gas meter if installed.

B - Supply Pressure Measurement

When testing supply gas pressure, use the 1/8" N.P.T. supply line tap located on the gas valve to facilitate test gauge connection. See figure 1. Check gas line pressure with unit firing at maximum rate. Low pressure may result in erratic operation or underfire. High pressure can result in permanent damage to gas valve or overfire.

On multiple unit installations, each unit should be checked separately, with and without units operating. Supply pressure must fall within range listed in table 2.

NOTE - To obtain accurate reading, shut off all other gas appliances connected to meter.

C - Manifold Pressure Measurement

When testing manifold gas pressure, use the 1/8" N.P.T. plugged tap (manifold pressure outlet) located on the gas valve to facilitate test measuring device. See figure 1.

- 1 - Remove the threaded manifold pressure outlet plug from the gas valve and install the barbed fitting.
- 2 - Take a length of square tubing and connect one end to the barbed fitting and the other to the positive "+" side of the measuring device.
- 3 - Take another length of tubing and "tee" into the gas valve regulator vent hose. Connect to the measuring device negative "-" side.

- 4 - Start unit and allow 5 minutes for unit to reach steady state.
- 5 - After allowing unit to stabilize for 5 minutes, record manifold pressure and compare to value given in table 2.
- 6 - If necessary make adjustment. Turn off unit and remove the tubing from the negative (-) barbed fitting on the gas valve.
- 7 - Remove the negative barbed fitting as shown in figure 1 and using a screw driver make adjustment to increase or decrease manifold pressure.
- 8 - Repeat steps 1 through 7 until manifold pressure is correct.
- 9 - Shut unit off and remove manometer as soon as an accurate reading has been obtained. Take care to replace pressure tap plug.
- 10 - Start unit and perform leak check. Seal leaks if found.

TABLE 2

Unit	Manifold Pressure in wg 0 - 7500 ft	Supply Line in wg	
		Min	Max
ML196UHE030 EL195UHE030 EL196UHE030	10.0	11.0	13.0

D - Proper Combustion

Furnace should operate minimum 15 minutes with correct manifold pressure and gas flow rate before checking combustion. Take combustion sample beyond the flue outlet and compare to table 3.

TABLE 3

Unit	CO2% For LP
ML196UHE030 EL195UHE030 EL196UHE030	8.6 - 9.6
The carbon monoxide reading should not exceed 100 ppm.	

E - Turning Off Gas To the Unit

- 1 - Set the thermostat to its lowest setting.
- 2 - Turn off all the electrical power to the unit.
- 3 - Remove the access panel.
- 4 - Move the switch on the gas valve to **OFF**. Do not force the switch.