

INSTALLATION INSTRUCTIONS

CH35 Series Units

INDOOR COILS WITH ALL-ALUMINUM COIL
507656-01
7/2018

**THIS MANUAL MUST BE LEFT WITH THE
HOMEOWNER FOR FUTURE REFERENCE**

⚠ WARNING

Improper installation, adjustment, alteration, service or maintenance can cause personal injury, loss of life, or damage to property.

Installation and service must be performed by a licensed professional installer (or equivalent) or a service agency.

⚠ WARNING

Risk of explosion or fire.

Can cause injury or death.

Recover all refrigerant to relieve pressure before opening the system.

⚠ CAUTION

As with any mechanical equipment, contact with sharp sheet metal edges can result in personal injury. Take care while handling this equipment and wear gloves and protective clothing.

⚠ IMPORTANT

The Clean Air Act of 1990 bans the intentional venting of refrigerant (CFCs, HCFCs and HFCs) as of July 1, 1992. Approved methods of recovery, recycling or reclaiming must be followed. Fines and/or incarceration may be levied for noncompliance.

NOTE - Not available in all areas. Contact your nearest Lennox Sales Office for details.

Table of Contents

General	1
Shipping and Packing List	1
Specifications	2
Releasing Air Charge	3
Installation	3
Refrigerant Line Connections	5
Leak Testing, Evacuating and Charging	6
Sealing Ducts	6
Condensate Drain Connection	6
Blower Speed Connection	7
Maintenance	8

General

CH35 **all-aluminum coil** horizontal evaporator coils are designed for use with air conditioners and heat pumps. Each coil is equipped with a compression fitting that provides convenient field installation of a properly sized, separately ordered expansion valve.

The coil drain pan is high quality engineering polymer with a maximum service temperature of 500°F. However, adequate space must be provided between the drain pan and furnace heat exchanger. At least 2" space is required for heat exchanger and 4" for drum-type or oil-fired furnace heat exchanger. Closer spacing may damage the drain pan and cause leaking.

Refer to the CH35 Product Specification bulletin (EHB) for proper use of these coils with specific furnaces, air conditioners, heat pumps and line sets.

These instructions are intended as a general guide and do not supersede local or national codes in any way. Consult authorities who have jurisdiction before installation.

IMPORTANT: Special procedures are required for cleaning the aluminum coil in this unit. See page 8 in this instruction for information.

Shipping and Packing List

Package 1 of 1 contains the following:

1 - CH35 evaporator coil

Check the components for shipping damage. If you find any damage, immediately contact the last carrier.

Model Number Identification

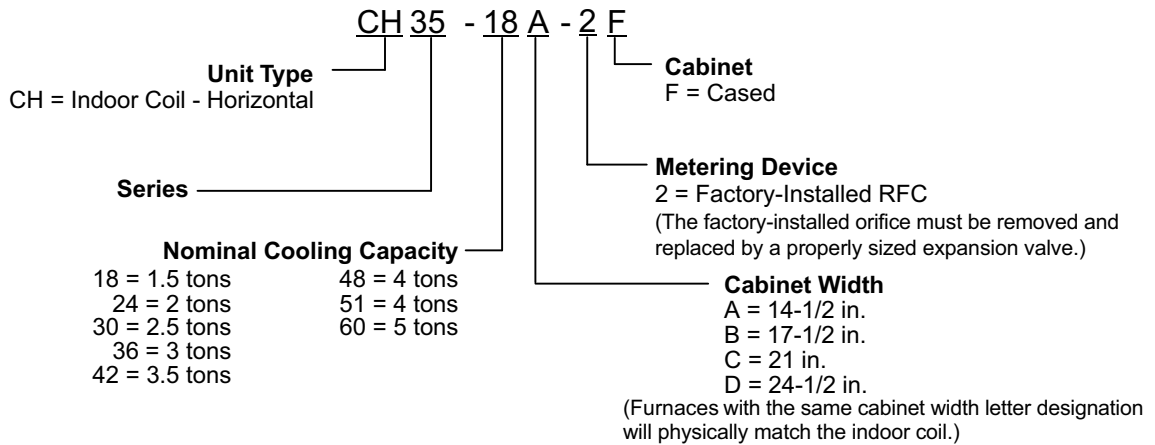

Specifications

General Data	Model No.	CH35 -18A-2F	CH35 -24A-2F	CH35 -24B-2F	CH35 -30A-2F	CH35 -30B-2F
	Nominal size - tons	1.5	2	2	2.5	2.5
Line Connections	Suction/Vapor o.d. - in. sweat	3/4	3/4	3/4	3/4	3/4
	Liquid o.d. - in. sweat	3/8	3/8	3/8	3/8	3/8
	Condensate drain (fpt) - in.	3/4	3/4	3/4	3/4	3/4
Evaporator Coil	Net face area - sq. ft.	1.75	3.5	3.5	4.33	4.67
	Tube diameter - in.	3/8	3/8	3/8	3/8	3/8
	Number of rows	2	3	2	3	3
	Fins per inch	18	14	19	16	14
Horizontal Matching Furnace	Cabinet Designation	A	A	B	A	B
	Coil and Furnace Height	14-1/2	14-1/2	17-1/2	14-1/2	17-1/2
Shipping Data	lbs. - 1 package	43	45	47	55	53

Specifications

General Data	Model No.	CH35 -36A-2F	CH35 -36B-2F	CH35 -36C-2F	CH35 -42B-2F	CH35 -42C-2F
	Nominal size - tons	3	3	3	3.5	3.5
Line Connections	Suction/Vapor o.d. - in. sweat	3/4	3/4	3/4	7/8	7/8
	Liquid o.d. - in. sweat	3/8	3/8	3/8	3/8	3/8
	Condensate drain (fpt) - in.	3/4	3/4	3/4	3/4	3/4
Evaporator Coil	Net face area - sq. ft.	3.5	4.67	5.83	5.78	5.83
	Tube diameter - in.	3/8	3/8	3/8	3/8	3/8
	Number of rows	3	2	2	3	3
	Fins per inch	12	18	18	12	13
Horizontal Matching Furnace	Cabinet Designation	A	B	C	B	C
	Coil and Furnace Height	14-1/2	17-1/2	21	17-1/2	21
Shipping Data	lbs. - 1 package	47	48	55	60	60

Specifications

General Data	Model No.	CH35 -48B-2F	CH35 -48C-2F	CH35 -51C-2F	CH35 -60D-2F
	Nominal size - tons	3.5 / 4	3.5 / 4	4	5
Line Connections	Suction/Vapor o.d. - in. sweat	7/8	7/8	7/8	7/8
	Liquid o.d. - in. sweat	3/8	3/8	3/8	3/8
	Condensate drain (fpt) - in.	3/4	3/4	3/4	3/4
Evaporator Coil	Net face area - sq. ft.	5.78	5.83	7.22	7.94
	Tube diameter - in.	3/8	3/8	3/8	3/8
	Number of rows	3	2	3	3
	Fins per inch	12	12	13	12
Horizontal Matching Furnace	Cabinet Designation	B	C	C	D
	Coil and Furnace Height	17-1/2	21	21	24-1/2
Shipping Data	lbs. - 1 package	60	59	69	78

Releasing Air Charge

CAUTION

The coil is shipped from the factory pressurized with dry air. Pierce a hole in the rubber plug that seals the vapor line to relieve the pressure before removing the plugs.

NOTE - If there is no pressure released when the vapor line rubber plug is pierced, check the coil for leaks before continuing with the installation.

The coil is shipped with a 10 ± 3 psig dry air holding charge. Puncture the suction line rubber plug to release the charge. Remove the rubber plug. Ensure that the coil is void of pressure.

Installation

WARNING

Risk of explosion or fire.

Can cause injury or death.

Recover all refrigerant to relieve pressure before opening the system.

Install the furnace or air handler according to the installation instructions provided with the unit.

NOTE - In areas of high humidity, use foam tape to insulate the suction line section in the cabinet as shown in figure 1.

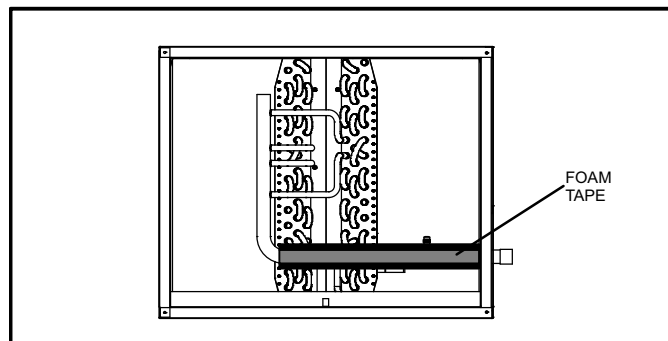

Figure 1. Insulate Suction Line Inside Cabinet

- 1. Left-Hand and Right-Hand Discharge** — The coil must have a 1/2" slope from the rear of the cabinet to the drain. Position the coil adjacent to the furnace cabinet and align the six screw clearance holes in the coil casing with the furnace engagement holes. Use six field-provided #8 X 1" screws to secure the coil casing to the furnace (see figures 3 and 4).
- 2. Right-Hand Air Discharge with Field-Provided Spacer** — The coil must have a 1/2" slope from the rear of the cabinet to the drain. Position the coil in the left-to-right configuration on the service access side of the furnace. Insert a field-provided spacer between the furnace and the coil. Use field-provided screws to secure the coil casing, spacer and the furnace together. The spacer should be long enough to allow room for proper installation (approximately 6 inches minimum). See figure 5.

NOTE - When the coil is connected directly with a condensing furnace, the coil must be level from return end to supply end. The front (access side) of the furnace may be pitched downward up to 1 inch to accommodate a 1/2-inch pitched coil.

3. Secure the supply duct to the coil cabinet.
4. Refer to the instructions provided with the condensing unit for leak testing, evacuating and charging procedures. **Always check the entire system for leaks before charging.**
5. **Applications using CH35-60 D-width unit with C-width furnace** — Figure 2 shows an application that includes a D-width coil and a C-width furnace. This application requires construction of an insulated, field-supplied block-off plate to cover the open space on the coil housing.

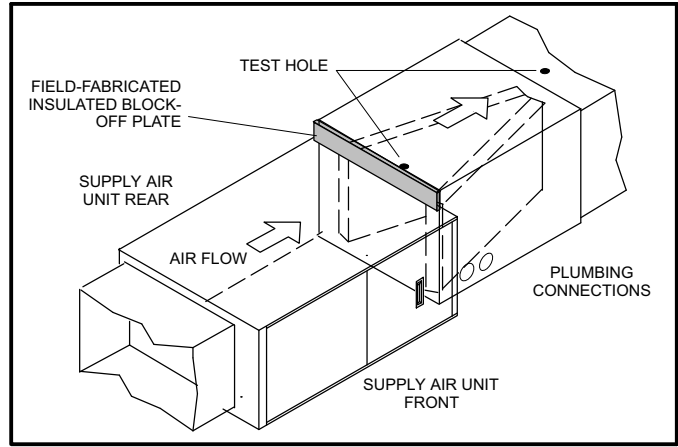

Figure 2. D-Width Coil with C-Width Furnace

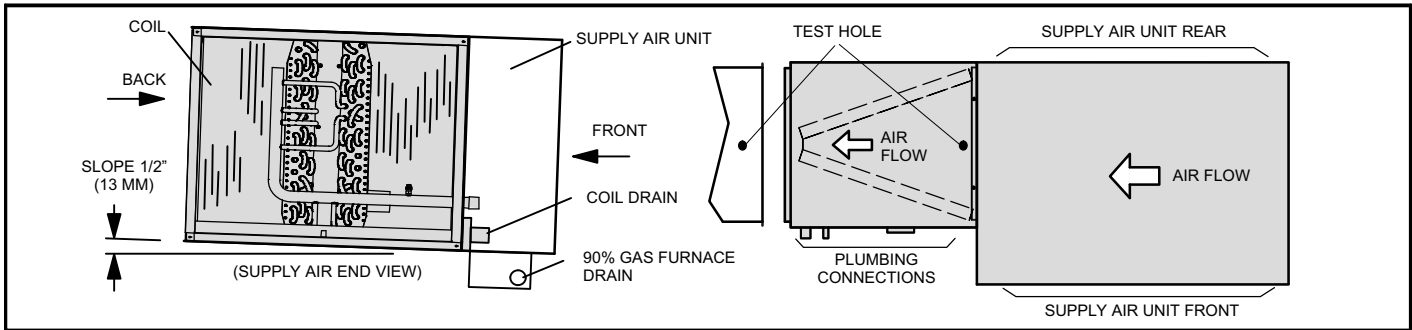

Figure 3. Left-Hand Air Discharge

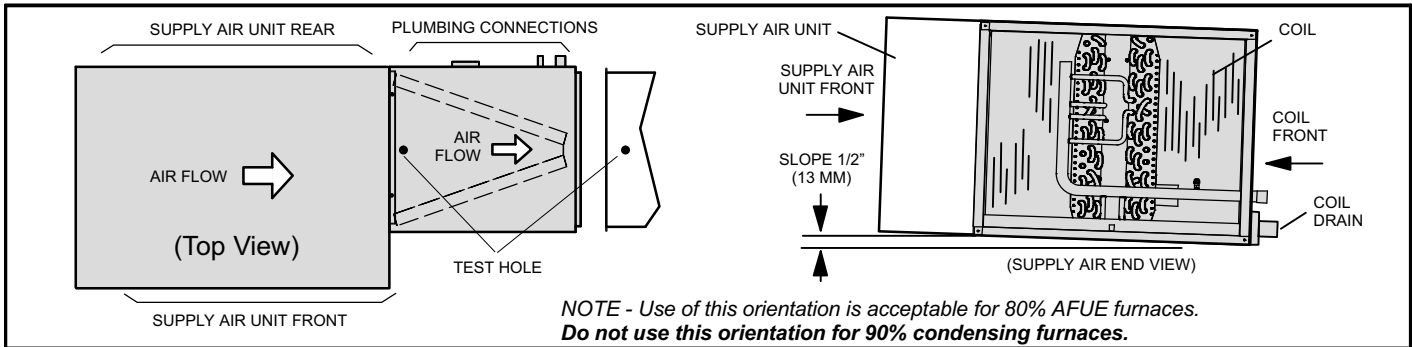

Figure 4. Right-Hand Air Discharge

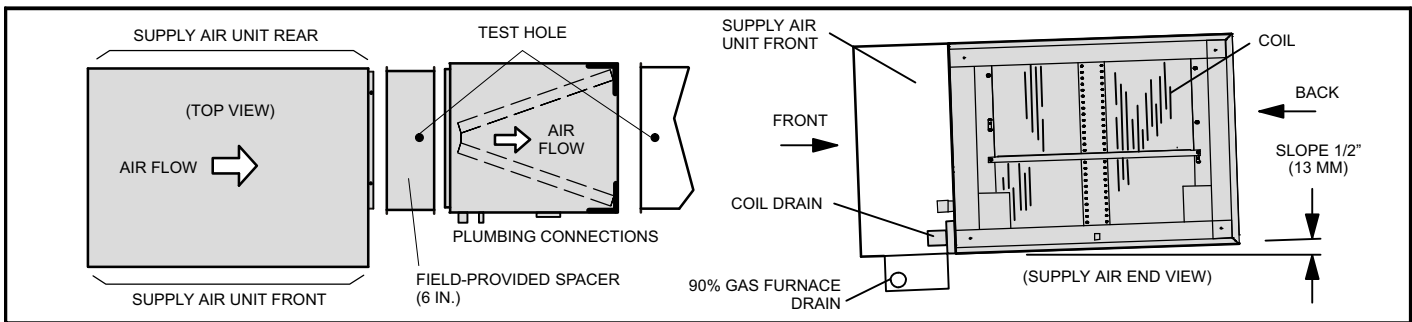

Figure 5. Right-Hand Air Discharge with Spacer

Refrigerant Line Connections

LINE SIZES

The refrigerant line sets should be sized according to the recommendations given in the outdoor unit installation instructions. See table 1 for sweat connection sizes. A field-provided adapter may be required to match line set connections.

Table 1. Refrigerant Line Connections

CH35 Model	Suction Line Connection	Liquid Line Connection
-18-2F -24-2F -30-2F -36-2F	3/4 Inch	3/8 Inch
-42-2F -48-2F -51-2F -60-2F	7/8 Inch	

REPLACEMENT PARTS

If replacement parts are needed for the liquid line orifice housing or assembly, order kit 69J46. The kit includes:

- 10 - Brass nuts for liquid line assemblies
- 20 - Teflon rings
- 10 - Liquid line orifice housings
- 10 - Liquid line assemblies

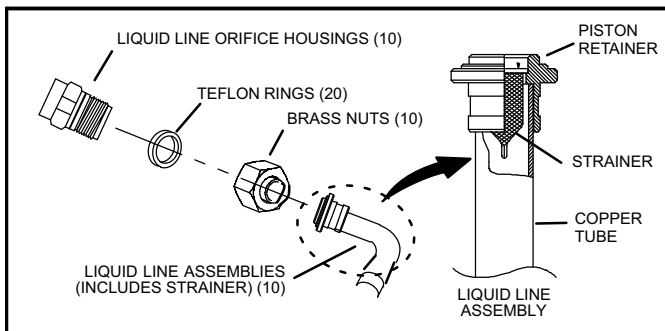

Figure 6. Liquid Line Orifice Kit (69J46) Components

BRAZING GUIDELINES

Use a silver alloy brazing rod (5 or 6 percent silver alloy for copper-to-copper connections or 45 percent silver alloy for copper-to-brass or copper-to-steel connections).

Use AL822 Flux Cord Solder Stickers (Lennox catalog number Y6331) for aluminum to aluminum joints.

Before making brazed connections, place a field-provided heat shield, such as a wet rag, against the unit cabinet and around the piping stubs. The heat shield must be in place to prevent heat damage during brazing. See figure 7.

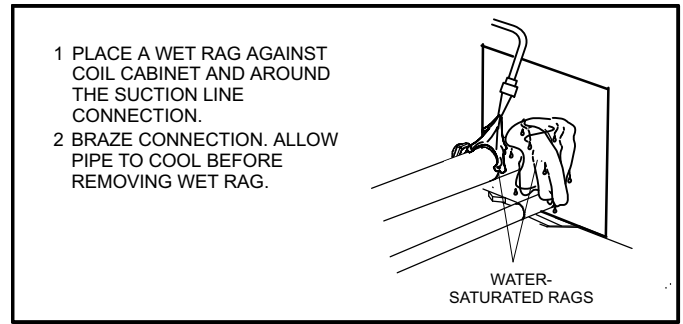

Figure 7. Brazing Refrigerant Lines

SUCTION LINE CONNECTION

Use the following procedure to connect the suction line to the indoor coil:

1. Remove rubber plug from the stubbed connection.
2. Position the properly sized refrigerant piping and make the brazed connection following the brazing guidelines.
3. Do not remove the water-saturated rags from the cabinet and piping until the piping has cooled completely.

Suction Line Equalizer Fitting

Remove the copper flare seat bonnet if present from the male equalizer line fitting (see figure 8).

IMPORTANT

When removing the flare nut, ensure that the copper flare seal bonnet is removed as illustrated in figure 8.

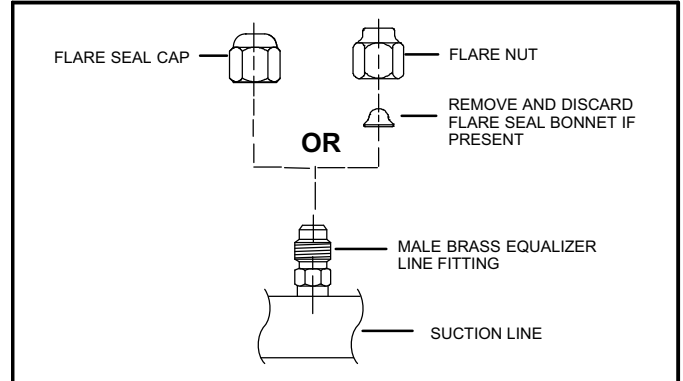

Figure 8. Suction Line Male Equalizer Line Fitting Modifications

LIQUID LINE CONNECTION

NOTE - Before the liquid line connections can be made, the factory-provided refrigerant metering orifice must be removed and a properly sized expansion valve must be field-installed.

The system must include a properly matched expansion valve which must be field-provided and installed. The CH35 is shipped with a factory-installed refrigerant metering orifice. **The orifice must be removed BEFORE a properly sized expansion valve is installed.**

Fixed Orifice Removal

1. Remove any shipping clamps holding the liquid line and distributor assembly.

2. **IMPORTANT:** Using two wrenches, disconnect the liquid line stub from the orifice housing. Take care not to twist or damage the distributor tubes during this process.
3. Remove and discard the existing orifice, valve stem assembly (if present) and Teflon ring as illustrated in figure 9.
4. Retain brass nut to be used later with the liquid line assembly.

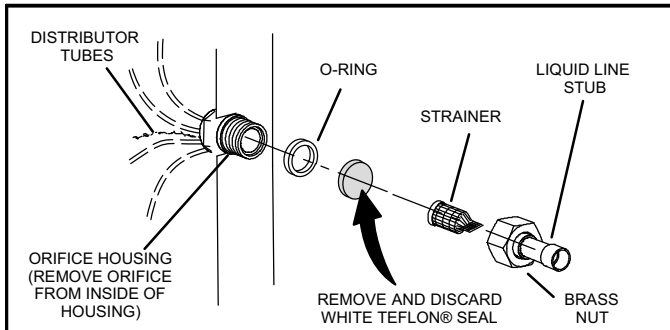

Figure 9. Typical Fixed Orifice Removal

Expansion Valve / Liquid Line Installation

A properly matched expansion valve **must** be used with the CH35 units. The expansion valve can be installed internal or external to the indoor coil cabinet. Refer to the instructions provided with the expansion valve kit for proper installation of the valve and sensing bulb.

See the CH35 Product Specification bulletin (EHB) for approved expansion valve match-ups and application information.

Leak Testing, Evacuating and Charging

Refer to the outdoor unit instruction for leak testing, evacuating and charging procedures. Always leak check entire system before charging.

The following best practices are recommended to ensure better condensate removal:

- Main and overflow drain lines should **NOT** be smaller than both drain connections at drain pan.
- Overflow drain line should run to an area where homeowner will notice drainage.
- It is recommended that the overflow drain line be vented and a trap installed. Refer to local codes.

Sealing Ducts

Ensure the duct is secured and all joints are properly sealed to the coil cabinet flanges.

! WARNING

There must be an airtight seal between the bottom of the furnace and the return air plenum. Use fiberglass sealing strips, caulking, or equivalent sealing method between the plenum and the air handler cabinet to ensure a tight seal. Return air must not be drawn from a room where this air handler or any gas-fueled appliance (i.e., water heater), or carbon monoxide-producing device (i.e., wood fireplace) is installed.

! IMPORTANT

DUCT SYSTEM SIZING - The duct system should be properly sized and installed according to the ASHRAE Standard Manual D. The supply and return air duct systems should be designed for the cfm and static requirements of the job. Consult the blower performance chart in the unit installation instructions to verify that the blower meets the application requirements.

Condensate Drain Connections

! IMPORTANT

After removal of drain pan plug(s), check drain hole(s) to verify that drain opening is fully open and free of any debris. Also check to make sure that no debris has fallen into the drain pan during installation that may plug up the drain opening.

MAIN DRAIN

Connect the main drain and route downward to drain line or sump. Do not connect drain to a closed waste system. See Figure 10 for typical drain trap configuration.

OVERFLOW DRAIN

It is recommended that the overflow drain is connected to a overflow drain line for all units. If overflow drain is not connected, it must be plugged with provided cap.

BEST PRACTICES

The following practices are recommended to ensure better condensate removal:

- Main and overflow drain lines should **NOT** be smaller than drain connections at drain pan.
- Overflow drain line should run to an area where homeowner will notice drainage.
- It is recommended that the overflow drain line be vented and a trap installed. Refer to local codes.

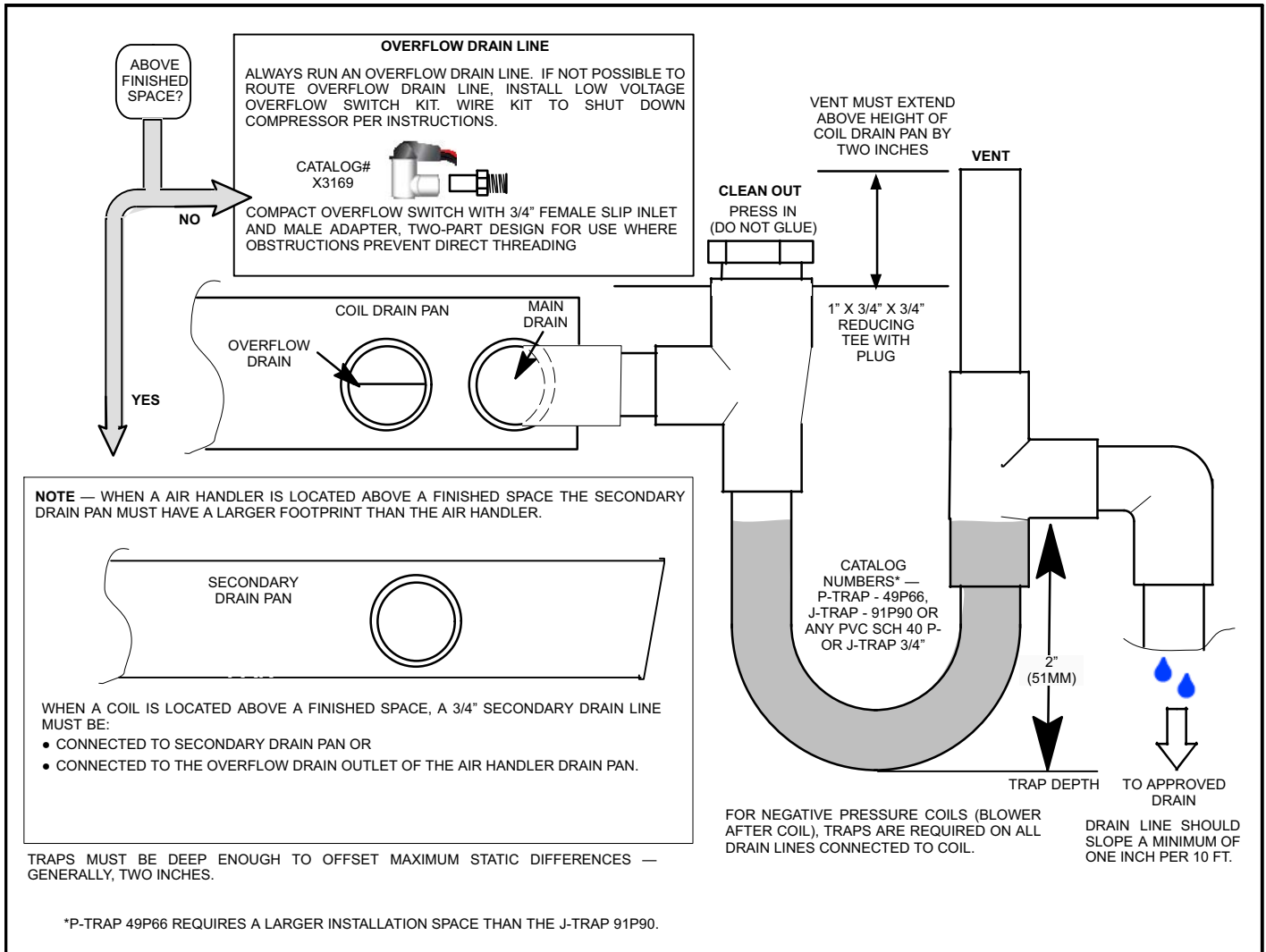

Figure 10. Typical Main and Overflow Drain Installations

Blower Speed Connection

Proper air volume must be provided over the evaporator coil. Select a blower motor speed tap that will provide 400 ± 50 CFM per 12,000 Btuh of cooling capacity (wet coil).

A static pressure reading must be taken to see if the pressure drops are within the proper range. See figure 11 as an example to obtain an accurate reading.

To ensure accuracy, test the air on both sides of the coil. Refer to figure 11 for location of two test holes.

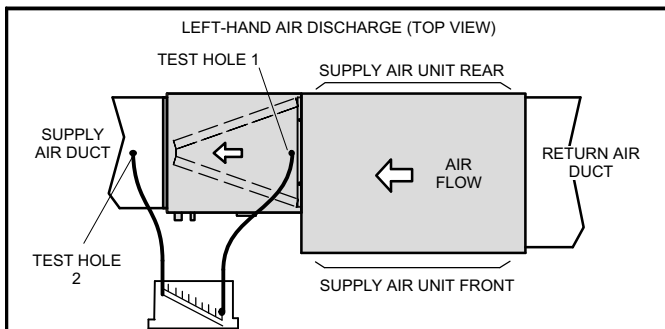

Figure 11. Static Pressure Test

CAUTION

Take care when drilling test holes into the furnace flange and the duct. Drill holes away from refrigerant piping. Test holes should be drilled where specified in order to avoid unit damage.

1. Drill a 5/16" test hole in the coil case 1" from the furnace flange (test hole 1, figure 11).
2. Drill a 5/16" test hole into the supply air duct (test hole 2, figure 11).
3. Connect the zero end of the draft gauge scale to the furnace end of the coil. Insert the hoses so that 1/4" extends inside the duct or end seal. Seal around holes with Permagum.
4. Turn on the electrical power to the furnace and set the thermostat to initiate a cooling demand.

- Table 2 lists the range of air volumes and equivalent draft gauge readings for this unit. Observe the draft gauge reading. If the reading is below the required air volume, increase the blower speed; if the reading is above the required air volume, decrease the blower speed. Refer to the furnace wiring diagram for blower speed settings.
- When the required draft gauge readings are obtained, remove the draft gauge lines and insert snaphole plugs into the test holes.

Table 2. Air Volume/Static Pressure Drop Across Coil

Cabinet		Vol: CFM	Drop: in. w.g.	
CH35 Model	Width in.		Dry	Wet
-18A-2F	14-1/2	600	.09	.11
-24A-2F	14-1/2	800	.15	.19
-24B-2F	17-1/2	800	.09	.11
-30A-2F	14-1/2	1000	.24	.27
-30B-2F	17-1/2	1000	.14	.16
-36A-2F	14-1/2	1200	.30	.39
-36B-2F	17-1/2	1200	.16	.21
-36C-F	21	1200	.15	.18
-42B-2F	14-1/2	1400	.26	.31
-42C-2F	17-1/2	1400	.18	.21
-48B-2F	17-1/2	1400	.25	.29
-48C-2F	21	1600	.27	.30
-51C-2F	21	1600	.25	.29
-60D-2F	24-1/2	2000	.24	.30

Maintenance

CLEANING THE COIL

The coil should be inspected twice each year and cleaned at least once per year or more, if necessary. Indoor coil cleaning should be performed by a licensed professional service technician (or equivalent).

⚠ CAUTION

A damaged coil fin can affect equipment operation and performance. Do not use flame, high-pressure water, steam, or volatile cleaners on fins or tubing surfaces. If cleaning requires the use of acidic or alkaline cleaners, follow the manufacturer's instructions. Thoroughly flush cleaner from all equipment components. (Be careful to prevent damage or corrosion of the components connected to the system or areas surrounding the equipment being cleaned.)

Do not use hydrofluoric acid, alkaline, or similar chemicals to clean coils. These chemicals are not necessary to dissolve salt, and may damage the fin coating. Acid washes are used to dissolve oils and greases, which generally are not present on residential applications.

Do not use alkaline washes. Alkaline washes are useful for dissolving oxides such as zinc oxide, aluminum oxide, and iron oxide (rust). However, these three oxides are more corrosion resistant than base metals, so dissolving or removing them will cause an increase in corrosion.

- Before beginning this or any other maintenance, turn off all power to the indoor unit at the main unit disconnect switch.** It is also recommended that you wear personal protective gear: safety glasses and/or a face shield, waterproof clothing and gloves.
- Remove the coil from the indoor unit cabinet, and take the coil to a place that is appropriate for cleaning it.
- Vacuum or brush the coil to remove matted and surface debris from the fins (dirt, hair, etc.). Use vacuum attachments and /or brushes that will not damage the coil fins.
- Use only clean potable water to clean the coil.** Clean the coil from top to bottom.

NOTE - For units in coastal regions, fresh water will dissolve away any salt deposits. (Wash coils with fresh water at least every six months.)

NOTICE !

Failure to follow instructions will cause damage to the unit. This unit is equipped with an aluminum coil. Aluminum coils may be damaged by exposure to solutions with a pH below 5 or above 9. The aluminum coil should be cleaned using potable water at a moderate pressure (less than 50psi). If the coil cannot be cleaned using water alone, Lennox recommends use of a coil cleaner with a pH in the range of 5 to 9. The coil must be rinsed thoroughly after cleaning. In coastal areas, the coil should be cleaned with potable water several times per year to avoid corrosive buildup (salt).

- Spray the coil at a vertical angle of 30 to 45 degrees with a constant stream of water at moderate pressure (less than 50 psig). A pressure washer with a fan nozzle will work best. Do not spray the coil from a horizontal direction.
- Direct the spray so that any debris is washed out of the coil and basepan. For most residential units, hot water is not necessary.

NOTE - Attempting to back flush from the inside of the coil will require removing parts from the unit, and it may be very difficult to flush the whole coil surface. Attempting to blow water through a coil will slow the water stream and reduce the flushing action of the outer fin surface.

- Replace the coil into the cabinet or plenum. Ensure that you have followed the proper procedure for routing and securing the refrigerant tubing.

⚠ IMPORTANT

Ensure that the distributor lines are not rubbing together or kinked. All tubes must have enough clearance from other metal parts. Use wire ties to secure tubes to prevent movement that could cause the refrigerant tubing to fail. Adjust the tubes as necessary.